

Industrial Robot: SCARA ROBOT

T-B series

MAINTENANCE MANUAL

Rev.4

ENM231R5598F

Original instructions

Industrial Robot: SCARA ROBOT

T-B series Maintenance Manual

Rev.4

©Seiko Epson Corporation 2021-2023

FOREWORD

Thank you for purchasing our robot products.

This manual contains the information necessary for the correct use of the manipulator and the integrated Controller.

Please carefully read this manual and other related manuals before installing the robot system.

Keep this manual handy for easy access at all times.

The robot system and its optional parts are shipped to our customers only after being subjected to the strictest quality controls, tests, and inspections to certify its compliance with our high performance standards. Please note that the basic performance of the product will not be exhibited if our robot system is used outside of the usage conditions and product specifications described in the manuals.

This manual describes possible dangers and consequences that we can foresee. Be sure to comply with safety precautions on this manual to use our robot system safely and correctly.

TRADEMARKS

Microsoft, Windows, and Windows logo are either registered trademarks or trademarks of Microsoft Corporation in the United States and/or other countries. Other brand and product names are trademarks or registered trademarks of the respective holders.

TRADEMARK NOTATION IN THIS MANUAL

Microsoft® Windows® 8 operating system

Microsoft® Windows® 10 operating system

Microsoft® Windows® 11 operating system

Throughout this manual, Windows 8, Windows 10 and Windows 11 refer to above respective operating systems. In some cases, Windows refers generically to Windows 8, Windows 10 and Windows 11.

NOTICE

No part of this manual may be copied or reproduced without authorization.

The contents of this manual are subject to change without notice.

Please notify us if you should find any errors in this manual or if you have any comments regarding its contents.

MANUFACTURER

SEIKO EPSON CORPORATION

CONTACT INFORMATION

Contact information is described in “SUPPLIERS” in the first pages of the following manual:

Robot System Safety Manual Read this manual first

DISPOSAL

When disposing this product, dispose in accordance with the laws and regulations of each country.

Regarding battery disposal

The battery removal/replacement procedure is described in the following manuals:

Maintenance Manual

For European Union customers only



The crossed out wheeled bin label that can be found on your product indicates that this product and incorporated batteries should not be disposed of via the normal household waste stream. To prevent possible harm to the environment or human health please separate this product and its batteries from other waste streams to ensure that it can be recycled in an environmentally sound manner. For more details on available collection facilities please contact your local government office or the retailer where you purchased this product. Use of the chemical symbols Pb, Cd or Hg indicates if these metals are used in the battery.

This information only applies to customers in the European Union, according to DIRECTIVE 2006/66/EC OF THE EUROPEAN PARLIAMENT AND OF THE COUNCIL OF 6 September 2006 on batteries and accumulators and waste batteries and accumulators and repealing Directive 91/157/EEC and legislation transposing and implementing it into the various national legal systems.

For other countries, please contact your local government to investigate the possibility of recycling your product.

For Users in Taiwan region



Please separate used batteries from other waste streams to ensure that it can be recycled in an environmentally sound manner. For more details on available collection facilities please contact your local government office or the retailer where you purchased this product.

For California customers only

The lithium batteries in this product contain
Perchlorate Material - special handling may apply,
See www.dtsc.ca.gov/hazardouswaste/perchlorate

Before Reading This Manual

This section describes what you should know before reading this manual.



NOTE “T-B” and “T-B series” described in this manual are the following models.

T3-B series

T6-B series



NOTE T-B series Manipulators can use the Teach Pendant (TP2, TP3). Do not connect the other devices to TP port except TP2 and TP3. Connecting other devices may result in malfunction of the device since the pin assignments are different.



NOTE Concerning the security support for the network connection:
The network connecting function (Ethernet) on our products assumes the use in the local network such as the factory LAN network. Do not connect to the external network such as Internet.

In addition, please take security measure such as for the virus from the network connection by installing the antivirus software.



NOTE Security support for the USB memory:

Make sure the USB memory is not infected with virus when connecting to the Manipulator.



NOTE If written T series in the reference information, read it as T-B series.

Features of T-B series Manipulators

The T-B series Manipulators are Controller integrated Manipulators.

Structure of Robot System

The T-B series Manipulators can be used with the following combinations of software.

T3-B401S, T6-B602S		Controller Firmware
		Ver.7.5.51.1 or later
EPSON RC+ 7.0	Ver.7.5.1 or earlier	!!!
	Ver.7.5.1A or later	OK

OK: Compatible All functions of the EPSON RC+ 7.0 and the robot system are available.

!!!: Compatible Connection is OK. It is recommended to use the EPSON RC+ 7.0 Ver.7.5.1A or later. Display or control may not be operated properly.

Shape of Motors

The shape of the motors used for the Manipulator that you are using may be different from the shape of the motors described in this manual because of the specifications.

Setting by Using Software

This manual contains setting procedures by using software. They are marked with the following icon.



The Manuals of This Product

The following are typical manual types for this product and an outline of the descriptions.

Safety Manual (book, PDF)

This manual contains safety information for all people who handle this product. The manual also describes the process from unpacking to operation and the manual you should look at next.

Read this manual first.

- Safety precautions regarding robot system and residual risk
- Declaration of conformity
- Training
- Flow from unpacking to operation

T-B series Manual (PDF) (Controller integrated Manipulators)

This manual describes the specifications and functions of the Manipulator. The manual is primarily intended for people who design robot systems.

- Technical information, functions, specifications, etc. required for the Manipulator installation and design
- Daily inspection of the Manipulator

Status Code/Error Code List (PDF)

This manual contains a list of code numbers displayed on the controller and messages displayed in the software message area. The manual is primarily intended for people who design robot systems or do programming.

T-B series Maintenance Manual (PDF) (Controller integrated Manipulators)

This manual describes the details of maintenance etc. The manual is intended for people who perform maintenance.

- Daily inspection
- Replacement and repair of maintenance parts
- The method of firmware update and controller setting backup etc.

EPSON RC+ 7.0 User's Guide (PDF)

This manual describes general information about program development software.

EPSON RC+ 7.0 SPEL+ Language Reference (PDF)

This manual describes the robot programming language "SPEL+".

Other Manual (PDF)

Manuals for each option are available.

T3-B T6-B Maintenance

1. Safety Maintenance	3
1.1 Conventions.....	3
1.2 Maintenance Precautions.....	4
2. General Maintenance	5
2.1 Maintenance Inspection	5
2.1.1 Schedule for Maintenance Inspection	5
2.1.2 Inspection Point.....	6
2.2 Overhaul (Parts Replacement).....	7
2.3 Greasing	9
2.4 Tightening Hexagon Socket Head Cap Bolts.....	12
2.5 Matching Origins.....	12
2.6 Layout of Maintenance Parts	13
3. Manipulator Structure	14
4. Alarm	16
4.1 Maintenance	17
4.2 Maintenance Information.....	18
4.2.1 How to View the Maintenance Information.....	18
4.2.2 How to Edit the Maintenance Information	19
4.2.3 Alarm Notifying Method	20
4.2.4 How to Cancel the Alarm.....	20
5. Backup and Restore	21
5.1 What is the Backup Controller Function.....	21
5.2 Backup Data Types	21
5.3 Backup.....	22
5.4 Restore	23
6. Firmware Update	26
6.1 Updating Firmware	26
6.2 Firmware Upgrade Procedure	26
6.3 Manipulator Recovery	29
6.4 Firmware Initialization Procedure.....	30
6.5 Adding Confirmation Steps by Strengthening Security of EtherNet Connection	32
7. Covers	36
7.1 Arm Top Cover	38
7.2 Arm Bottom Cover	39

7.3	Power Cable Cover	39
7.4	Connector Plate	40
7.5	Power Unit Cover	42
7.6	Base Side Cover	43
7.7	User Plate.....	44
8. Cable		45
8.1	Replacing Cable Unit	46
8.2	Insert or Pull out of Power Cable	54
9. Joint #1		55
9.1	Replacing Joint #1 Motor	56
9.2	Replacing Joint #1 Reduction Gear Units.....	70
10. Joint #2		73
10.1	Replacing Joint #2 Motor	74
10.2	Replacing Joint #2 Reduction Gear Units.....	80
11. Joint #3		83
11.1	Replacing Joint #3 Motor	84
11.2	Replacement of the timing belt	93
11.3	Replacing the Brake.....	94
11.4	Checking the Timing Belt Tension (Z Belt)	95
12. Joint #4		96
12.1	Replacing Joint #4 Motor	98
12.2.1	U2 Belt (T6-B)	105
12.2.2	U1 Belt (T6-B)	110
12.2.3	U Belt (T3-B)	111
12.3	Checking the Timing Belt Tension	112
13. Ball Screw Spline Unit		113
14. Lithium Battery, SD Card, and Boards		116
14.1	Replacing the CPU/DPB Boards.....	117
14.2	Replacing the Lithium Battery	120
14.3	Replacing the SD Card	121
14.4	Replacing the Power Board	122
14.5	Fieldbus I/O	124

15. LED Lamp Unit	126
16. RESET Switch	128
17. Calibration	129
17.1 About Calibration	129
17.2 Calibration Procedure.....	130
17.3 Accurate Calibration of Joint #2	140
17.4 Reference: Calibration Procedure Without Using Calibration Wizard	142
18. Error Code Table	146
19. Maintenance Parts List	147
19.1 T3-B	148
19.2 T6-B	149

T3-B T6-B Maintenance

This volume contains maintenance procedures with safety precautions for T-B series Manipulators.



1. Safety Maintenance

Please read this chapter, this manual, and other relevant manual carefully to understand safe maintenance procedures before performing any maintenance.



Only personnel who has taken maintenance training held by us and suppliers should be allowed to perform the maintenance of robot system.

1.1 Conventions

Important safety considerations are indicated throughout the manual by the following symbols. Be sure to read the descriptions shown with each symbol.

 WARNING	This symbol indicates that a danger of possible serious injury or death exists if the associated instructions are not followed properly.
 WARNING	This symbol indicates that a danger of possible serious injury or death caused by electric shock exists if the associated instructions are not followed properly.
 CAUTION	This symbol indicates that a danger of possible harm to people or physical damage to equipment and facilities exists if the associated instructions are not followed properly.

1.2 Maintenance Precautions

 <p>WARNING</p>	<ul style="list-style-type: none"> ■ Do not remove any parts and maintenance that are not covered in this manual. Improper removal of parts or improper maintenance may not only cause improper function of the robot system but also serious safety problems. ■ Keep away from the Manipulator while the power is ON if you have not taken the training courses. Do not enter the operating area while the power is ON. Entering the operating area with the power ON is extremely hazardous and may cause serious safety problems as the Manipulator may move even it seems to be stopped. ■ When you check the operation of the Manipulator after replacing parts, be sure to check it while you are outside of the safeguarded area. Checking the operation of the Manipulator while you are inside of the safeguarded area may cause serious safety problems as the Manipulator may move unexpectedly. ■ Before operating the robot system, make sure that both the Emergency Stop switches and safeguard switch function properly. Operating the robot system when the switches do not function properly is extremely hazardous and may result in serious bodily injury and/or serious damage to the robot system as the switches cannot fulfill their intended functions in an emergency.
 <p>WARNING</p>	<ul style="list-style-type: none"> ■ To shut off power to the robot system, disconnect the power plug from the power source. Be sure to connect the AC power cable to a power receptacle. DO NOT connect it directly to a factory power source. ■ Before performing any replacement procedure, turn OFF the robot system and related equipment, and then disconnect the power plug from the power source. Performing any replacement procedure with the power ON is extremely hazardous and may result in electric shock and/or malfunction of the robot system. ■ Be sure to connect the cables properly. Do not allow unnecessary strain on the cables. (Do not put heavy objects on the cables. Do not bend or pull the cables forcibly.) Damaged cables, disconnection, or contact failure is extremely hazardous and may result in electric shock and/or improper function of the robot system.
 <p>CAUTION</p>	<ul style="list-style-type: none"> ■ Manipulator may be warmed up due to motor heat or similar causes. Do not touch the Manipulator until temperature falls. Also, make sure the temperature of the Manipulator falls and is not hot when you touch it. Then perform teaching or maintenance. ■ When performing maintenance on the Manipulator, secure an empty space of about 50 cm around the Manipulator.

2. General Maintenance

Performing maintenance inspections and procedures properly is essential for preventing trouble and ensuring safety. This chapter describes maintenance inspections and procedures. Be sure to perform the maintenance inspections in accordance with the schedule.

2.1 Maintenance Inspection

2.1.1 Schedule for Maintenance Inspection

Inspection points are divided into five stages: daily, monthly, quarterly, biannual, and annual. The inspection points are added every stage. If the Manipulator is operated for 250 hours or longer per month, the inspection points must be added every 250 hours, 750 hours, 1500 hours, and 3000 hours operation.

	Inspection Point					
	Daily inspection	Monthly inspection	Quarterly inspection	Biannual inspection	Annual inspection	Overhaul (replacement)
1 month (250 h)	Inspect every day	√				
2 months (500 h)		√				
3 months (750 h)		√	√			
4 months (1000 h)		√				
5 months (1250 h)		√				
6 months (1500 h)		√	√	√		
7 months (1750 h)		√				
8 months (2000 h)		√				
9 months (2250 h)		√	√			
10 months (2500 h)		√				
11 months (2750 h)		√				
12 months (3000 h)		√	√	√	√	
13 months (3250 h)		√				
⋮	⋮	⋮	⋮	⋮	⋮	
(20000 h)					√	

2.1.2 Inspection Point

Inspection Item

Inspection Point	Inspection Place	Daily	Monthly	Quarterly	Biannual	Annual
Check looseness or backlash of bolts/screws.	End effector mounting bolts	√	√	√	√	√
	Manipulator mounting bolts	√	√	√	√	√
Check looseness of connectors.	External connectors on Manipulator (on the connector plates etc.)	√	√	√	√	√
Visually check for external defects. Clean up if necessary.	External appearance of Manipulator	√	√	√	√	√
	External cables	-	√	√	√	√
Check for bends or improper location. Repair or place it properly if necessary.	Safeguard etc.	√	√	√	√	√
Check the brake operation	Brake for arm #3	√	√	√	√	√
Check whether unusual sound or vibration occurs.	Whole	√	√	√	√	√
Check the power supply behavior.	Controller	-	-	-	-	√
Check behavior of the emergency stop button and safeguard.	Emergency stop button	-	-	-	-	√
	Safeguard	-	-	-	-	√

Inspection Method

Inspection Point	Inspection Method
Check looseness or backlash of bolts/screws.	Use a hexagonal wrench to check that the end effector mounting bolts and the Manipulator mounting bolts are not loose. When the bolts are loose, refer to "2.4 Tightening Hexagon Socket Head Bolts" and tighten them to the proper torque.
Check looseness of connectors.	Check that connectors are not loose. When the connectors are loose, reattach it not to come off.
Visually check for external defects. Clean up if necessary.	Check the appearance of the Manipulator and clean up if necessary. Check the appearance of the cable, and if it is scratched, check that there is no cable disconnection.
Check for bends or improper location. Repair or place it properly if necessary.	Check that the safeguard, etc. are located properly. If the location is improper, place it properly.
Check the brake operation	Check that the shaft does not fall when in MOTOR OFF. If the shaft falls when in MOTOR OFF and the brake is not released, contact the supplier. If the brake is not released when releasing the brake, contact the supplier.
Check whether unusual sound or vibration occurs.	Check that there is no unusual sound or vibration when operating. If there is something wrong, contact the supplier.
Check the power supply behavior.	Turn OFF and ON the power supply, and check that it starts without any error.
Check behavior of the emergency stop button	Operate emergency stop switch with the motor energized, then check the LED lamp on the top of the power unit lights off and the ESTOP LED on the Controller lights up. If EPSON RC+ is connected, make sure to check "EStop" is displayed in red on the status bar.
Check behavior of the safeguard.	Operate safeguard with the motor energized, then check the LED lamp on the top of the power unit lights off. If EPSON RC+ is connected, make sure to check "Safety" is displayed in blue on the status bar.

2.2 Overhaul (Parts Replacement)



CAUTION

- If you do not overhaul properly, it may have a serious impact on safety.
- Overhaul timing is based on an assumption that all joints are operated for equal distance. If a particular joint has a high duty or high load, it is recommended to overhaul all joints (as many as possible) before exceeding 20,000 operation hours with the joint as a basis.

The parts for the manipulator joints may cause accuracy decline or malfunction due to deterioration of the manipulator resulting from long term use. In order to use the manipulator for a long term, it is recommended to overhaul the parts (parts replacement).

The time between overhauls is 20,000 operation hours of the Manipulator as a rough indication.

However, it may vary depending on ambient temperature, usage condition and degree of the load (such as when operated with the maximum motion speed and maximum acceleration / deceleration in continuous operation) applied on the Manipulator.

NOTE



For the EPSON RC+ 7.0 the recommended replacement time for the parts subject to maintenance (motors, reduction gear units, and timing belts) can be checked in the [Maintenance] dialog box.

Refer to “4. Alarm”.

NOTE:

The recommended replacement time for the maintenance parts is when it reaches the L10 life (time until 10% failure probability).

In the [Maintenance] dialog box, the L10 life is displayed as 100%.

The manipulator operation hours can be checked in [Controller Status Viewer] dialog - [Motor On Hours].

- (1) Select the EPSON RC+ 7.0 menu-[Tools]-[Controller] to display the [Controller Tools] dialog box.
- (2) Click the <View Controller Status> button to open the [Browse For Folder] dialog.
- (3) Select the folder where the information is stored.
- (4) Click <OK> to view the [Controller Status Viewer] dialog.
- (5) Select [Robot] from the tree menu on the left side.

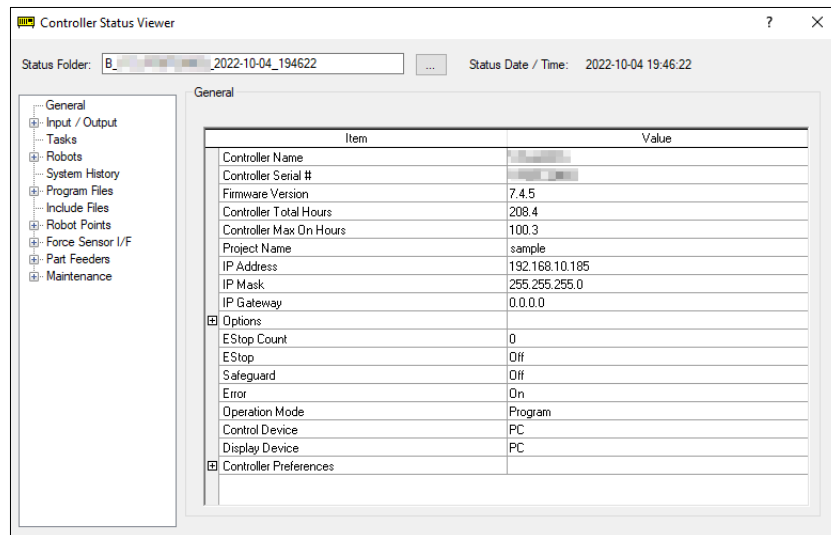

For the parts subject to overhaul, refer to “19. Maintenance Parts List”.

For details of replacement of each part, refer to each section.

Please contact the supplier of your region for further information.

2.3 Greasing

The ball screw spline and reduction gear units need greasing regularly. Only use the grease specified in the following table.

 CAUTION	<ul style="list-style-type: none"> Keep enough grease in the Manipulator. Operating the Manipulator with insufficient grease will damage sliding parts and/or result in insufficient function of the Manipulator.
--	--

 CAUTION	<ul style="list-style-type: none"> If grease gets into your eyes, mouth, or on your skin, follow the instructions below. <ul style="list-style-type: none"> If grease gets into your eyes <ul style="list-style-type: none"> : Flush them thoroughly with clean water, and then see a doctor immediately. If grease gets into your mouth <ul style="list-style-type: none"> : If swallowed, do not induce vomiting. See a doctor immediately. If grease just gets into your mouth, wash out your mouth with water thoroughly. If grease gets on your skin <ul style="list-style-type: none"> : Wash the area thoroughly with soap and water.
--	--

	Greasing part	Greasing Interval	Grease	How to grease
Joint #1	Reduction gear units	Overhaul timing	SFB No.1	9. Joint #1
Joint #2				10. Joint #2
Joint #3	Ball screw spline unit	At 100 km of operation (50 km for first greasing)	AFB	<i>Greasing the Ball Screw Spline Unit (See below)</i>

Joint #1, 2 reduction gear units

As a rough indication, perform greasing at the same timing as overhaul.

However, it may vary depending on ambient temperature, usage condition and degree of the load (such as when operated with the maximum motion speed and maximum acceleration / deceleration in continuous operation) applied on the Manipulator.

Joint #3 Ball screw spline unit

The recommended greasing interval is at 100 km of operation. However, greasing timing also can be checked from the grease condition. Perform greasing if the grease is discolored or becomes dry.

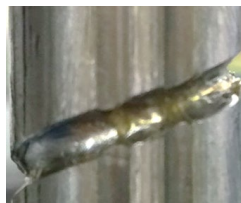

Normal grease

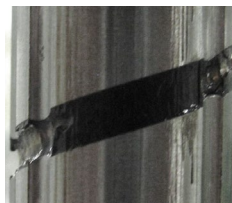

Discolored grease



Perform greasing at 50 km of operation for the first time of greasing.

For the EPSON RC+ 7.0 the recommended replacement time for the grease on the ball screw spline unit can be checked in the [Maintenance] dialog box.

Refer to "4. Alarm".

Greasing the Ball Screw Spline Unit

	Name	Quantity	NOTE
Grease	For Ball Screw Spline Unit (AFB grease)	Proper quantity	
Tools	Wiping cloth	1	For wiping grease (Spline shaft)

NOTE
 Cover the surrounding area such as the end effector and peripheral equipment in case the grease drips.

- (1) Turn ON the Controller.
- (2) Move the shaft to its lower limit in one of the following methods.
 - Move the shaft to its lower limit manually while pressing the brake release switch.

NOTE
 Be careful of the shaft falling and rotating while the brake release switch is being pressed because the shaft may be lowered by the weight of the end effector.

NOTE
 EPSON RC+ 7.0 [Tools]-[Robot Manager]-[Jog & Teach].

Make sure that the hand does not interfere with peripheral equipment.

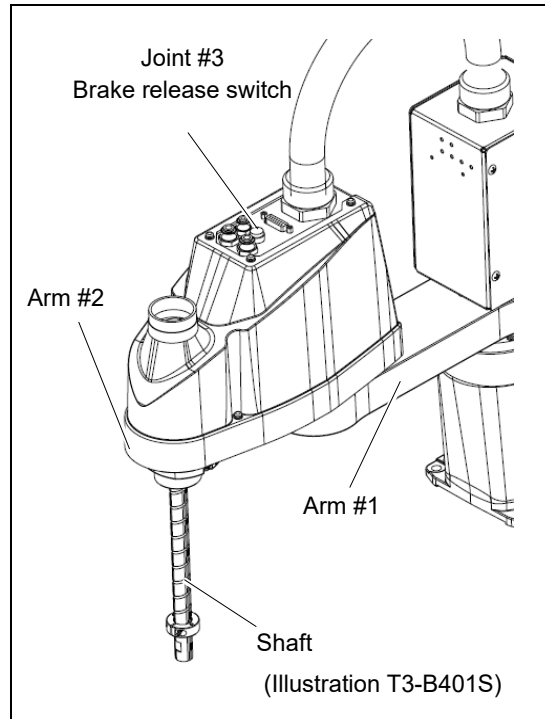

- (3) Turn OFF the Controller.
- (4) Wipe off the old grease from the shaft, and then apply new grease to it.

Grease application range is from the end of the spline nut to mechanical stop.

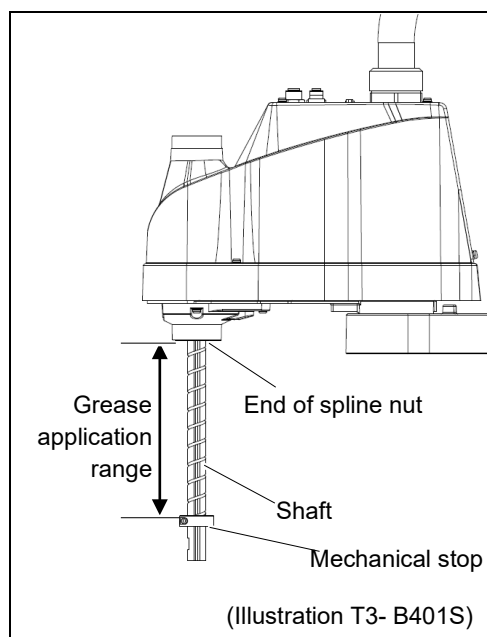

- (5) Apply grease evenly to the spiral groove of the ball screw spline unit and the vertical groove so that the groove is filled.



Grease application example

- (6) Turn ON the Controller.
- (7) Start the robot manager and move the shaft to the origin position. Be careful not to hit peripheral equipment.
- (8) After moving to the origin position, reciprocate the shaft. The reciprocating operation is a low power mode operation program that performs from the upper limit to the lower limit. Run for about 5 minutes to spread the grease over the shaft.
- (9) Turn OFF the Controller.
- (10) Wipe off excess grease on the end of the spline nut and mechanical stop.

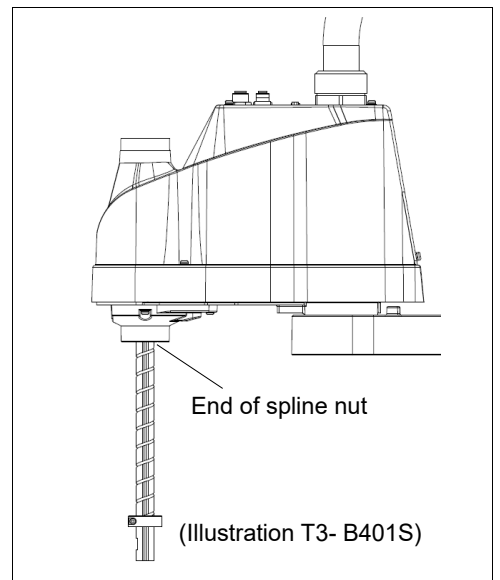

2.4 Tightening Hexagon Socket Head Cap Bolts

Hexagon socket head cap bolts (herein after referred to as bolt) are used in places where mechanical strength is required. These bolts are fastened with the tightening torques shown in the following table.

When it is necessary to refasten these bolts in some procedures in this manual (except special cases as noted), use a torque wrench so that the bolts are fastened with the appropriate tightening torques as shown below.

Bolt	Tightening torque
M3	2.0± 0.1 N·m (21 ± 1 kgf·cm)
M4	4.0± 0.2 N·m (41 ± 2 kgf·cm)
M5	8.0± 0.4 N·m (82 ± 4 kgf·cm)
M6	13.0± 0.6 N·m (133 ± 6 kgf·cm)
M8	32.0± 1.6 N·m (326 ± 16 kgf·cm)
M10	58.0± 2.9 N·m (590 ± 30 kgf·cm)
M12	100.0± 5.0 N·m (1,020 ± 51 kgf·cm)

Refer below for the set screw.

Set Screw	Tightening torque
M4	2.4± 0.1 N·m (26 ± 1 kgf·cm)
M5	4.0± 0.2 N·m (41 ± 2 kgf·cm)

The bolts aligned on a circumference should be fastened in a crisscross pattern as shown in the figure below.

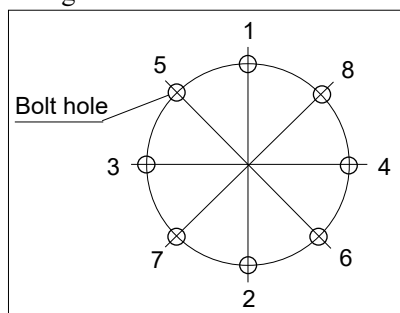

Do not fasten all bolts securely at one time.
Divide the number of times that the bolts are fastened into two or three and fasten the bolts securely with a hexagonal wrench.

2.5 Matching Origins

After parts have been replaced (motors, reduction gear units, a brake, timing belts, ball screw spline unit, etc.), the Manipulator cannot operate properly because a mismatch exists between the origin stored in each motor and its corresponding origin stored in the Robot system.

Because of that, it is necessary to perform calibration (encoder rest and calibration) to match these origins.

For calibration, the pulse values for a specific position must be recorded in advance.

Before replacing parts, select easy point (pose) data from the registered point data to check the accuracy. Then, follow the steps below to display the pulse values and record them.

**EPSON
RC+**

Execute the following command from the [Command Window].

```
>PULSE
```

```
PULSE: [Joint #1 Pulse value] pls [Joint #2 Pulse value] pls [Joint #3 Pulse value] pls  
[Joint #4 Pulse value] pls
```

2.6 Layout of Maintenance Parts

T3-B

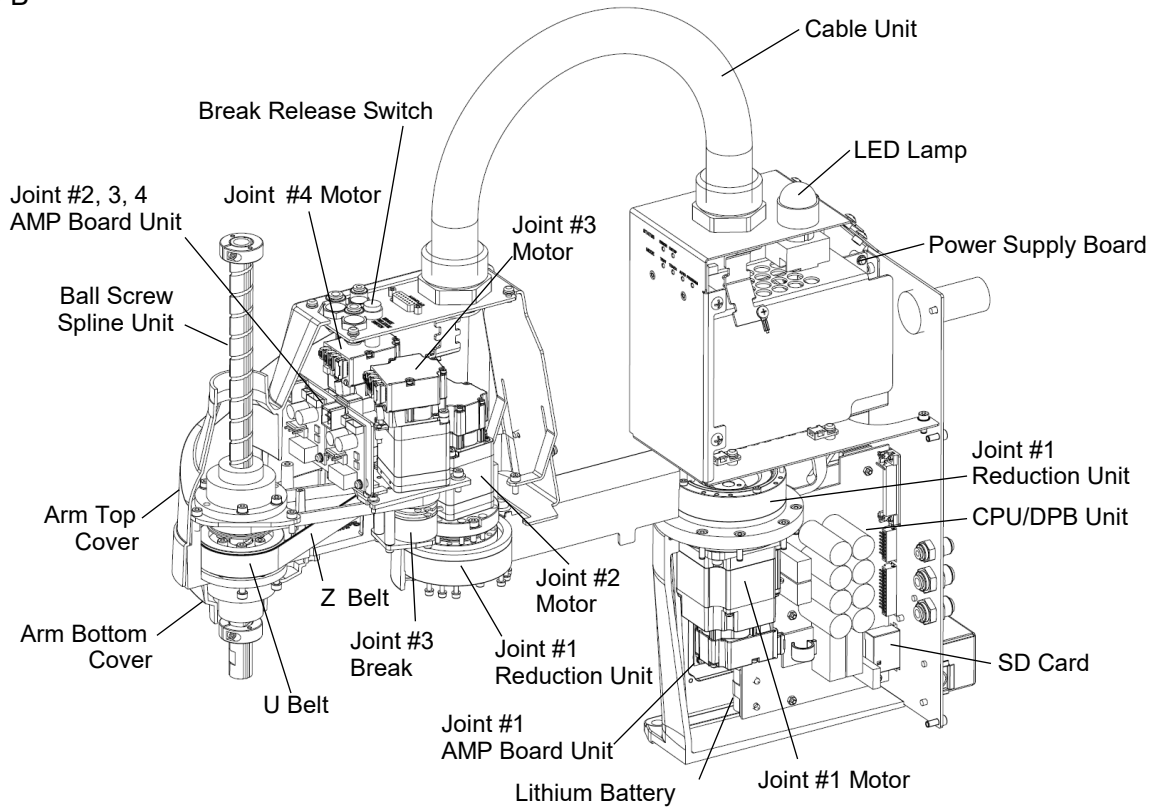

T6-B

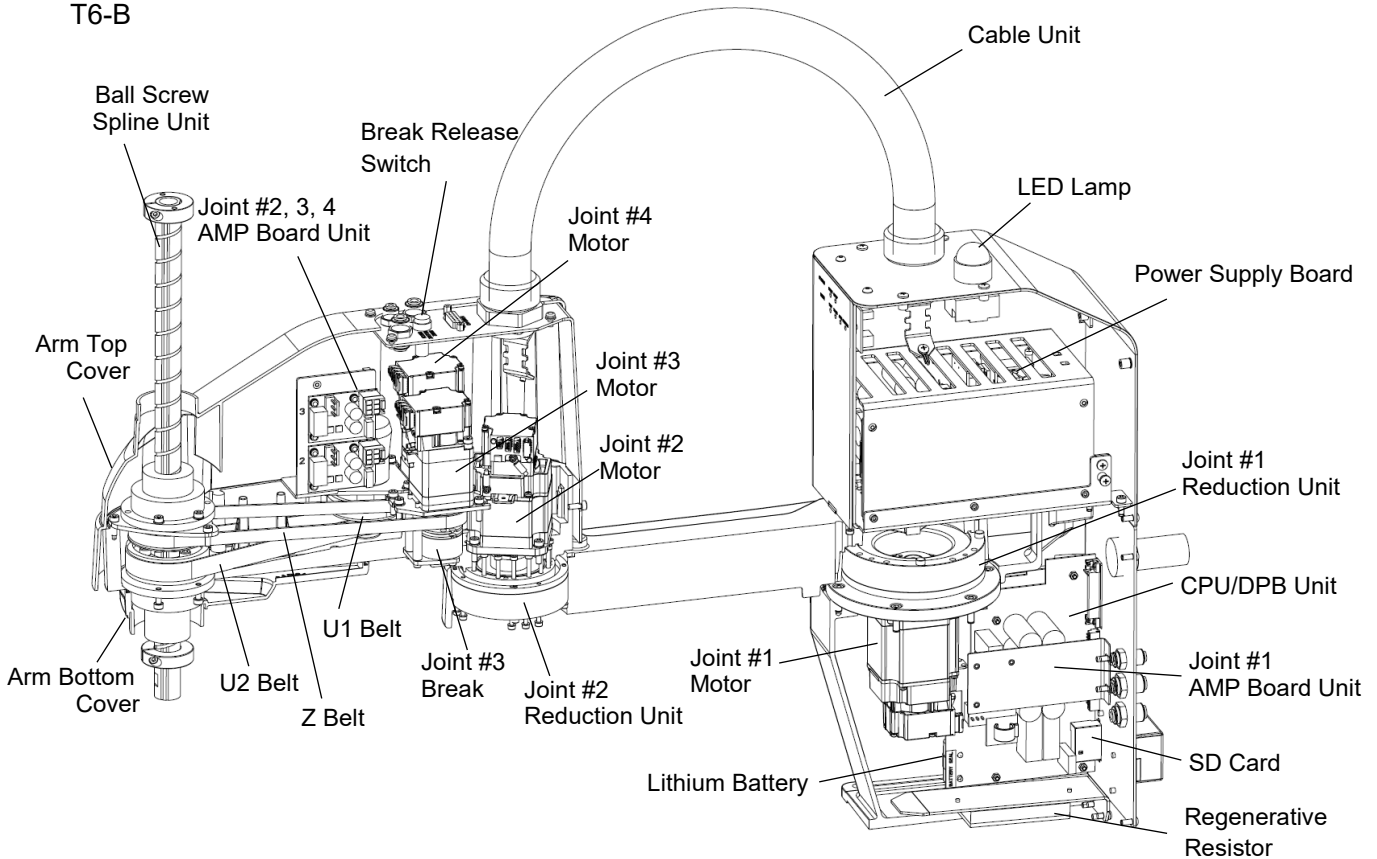

3. Manipulator Structure

T3-B

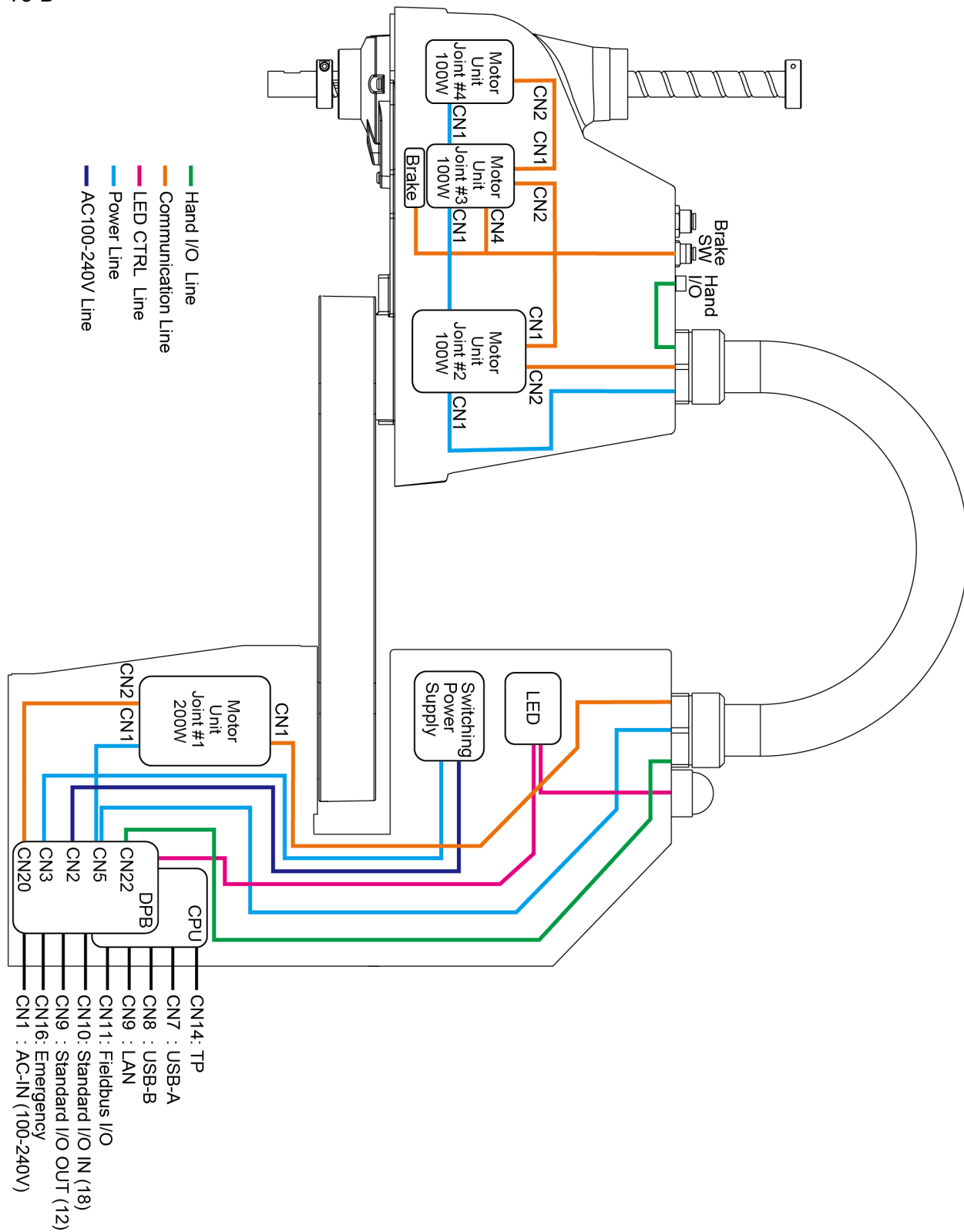

T6-B

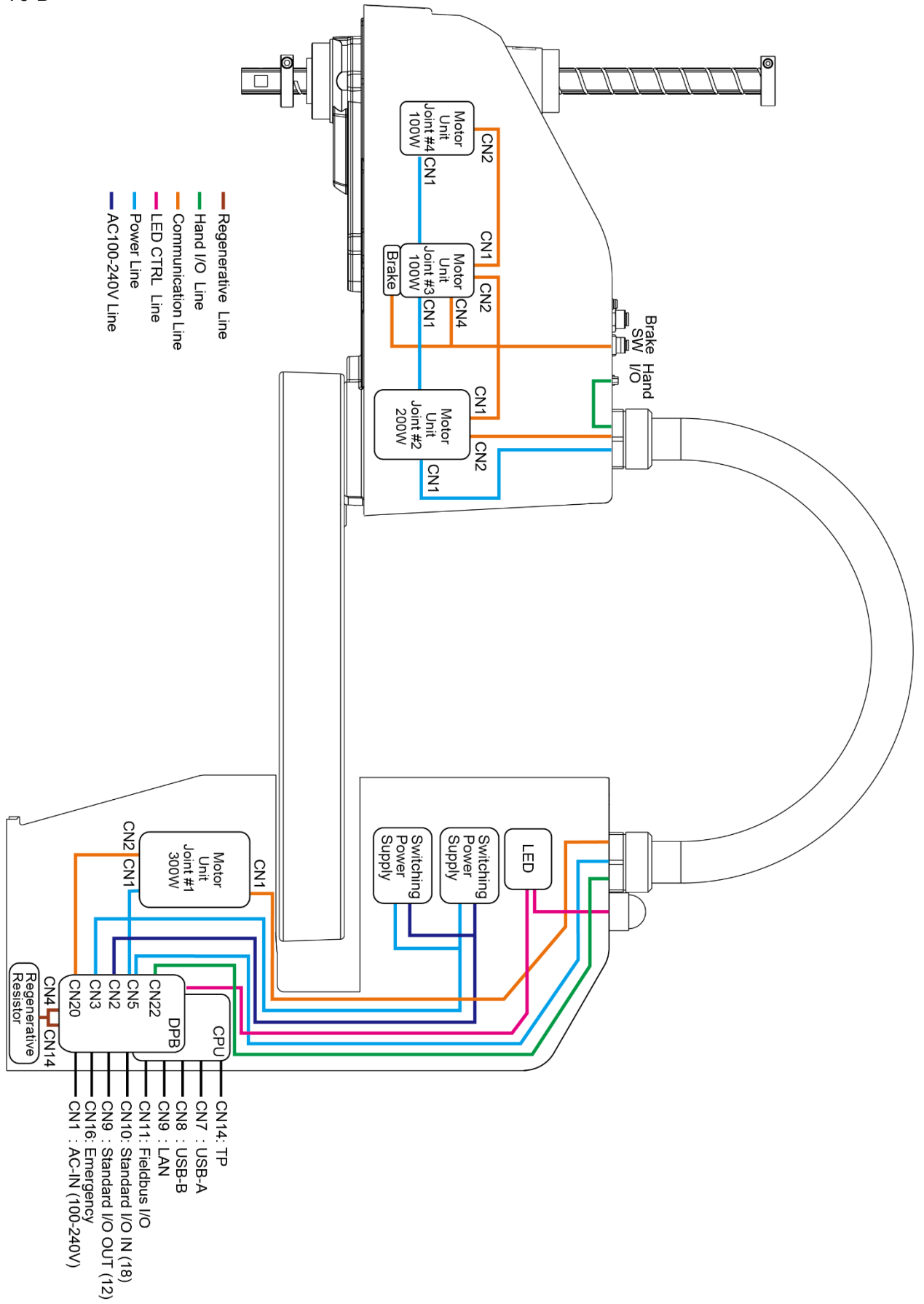

4. Alarm

When the lithium batteries run out, a voltage reduction alarm warning occurs. However, the warning does not guarantee that the battery lasts until you replace it.

If the battery has run out, the manipulator parameters will be lost and recalibration of the manipulator will be required. If the manipulator breaks down due to deterioration of the parts, it will take significant time and cost for repair.

The following sections describe the alarm function which announces the following maintenance timings in order to perform maintenance well ahead of time before the warning error.

- Battery replacement
- Grease up
- Replacement of the timing belt
- Replacement of the motor
- Replacement of the reduction gear unit
- Replacement of the ball screw spline unit

4.1 Maintenance

The recommended replacement time can be configured for the batteries, grease, timing belts, motors, reduction gear units, and ball screw spline units.

 CAUTION	<ul style="list-style-type: none"> ■ Make sure that the date and time on the Manipulator are set correctly. Maintenance cannot be performed properly with improper date and time setting. ■ If the CPU/DPB board or SD card is replaced, the Maintenance information may be lost. When you replaced these parts, confirm the date and time of the Manipulator and the Maintenance information.
---	--

NOTE Settings of the Maintenance are different depending on installation methods of the firmware.



Initial installation: Maintenance is enabled.

Upgrade: Maintenance inherits the previous data.
(Disables as default)

For details for enabling or disabling the Maintenance, refer to the *EPSON RC+ 7.0 User's Guide* 5.13.2 [System Configuration] Command (Setup Menu) - [Setup]-[System Configuration]-[Controller]-[Preferences] Page.

NOTE



Maintenance is enabled at shipment.

If enabled, the Maintenance information for the battery, timing belts, motors, reduction gear units, ball screw spline unit, and grease up will be configured automatically when the robot is configured or changed.

The following parts are subject to grease up: Ball screw spline unit on the Joint # 3

When the manipulator is deleted from the configuration, the Maintenance information will also be automatically deleted.

For details on the manipulator configuration, refer to the *EPSON RC+ 7.0 User's Guide* "10.1 Setting the Robot Model".

 CAUTION	<ul style="list-style-type: none"> ■ Changing of the manipulator should be done carefully. The alarm setting will be reset when the manipulator is changed.
---	--

If the Maintenance is enabled, the battery is automatically configured at the first connection.

4.2 Maintenance Information

4.2.1 How to View the Maintenance Information

The configured Maintenance information can be checked in the EPSON RC+.

- (1) Select the EPSON RC+ 7.0 menu-[Tools]-[Controller] to display the [Controller Tools] dialog box.

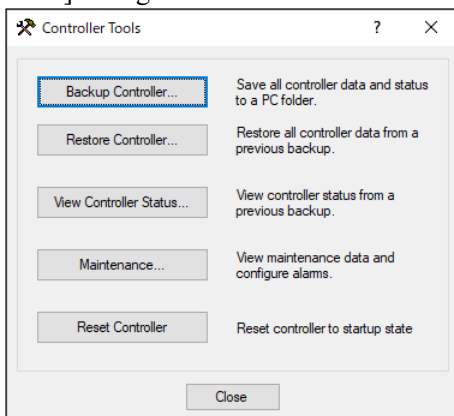

- (2) To check the controller Maintenance information, click the <Maintenance> button and display the [Maintenance] dialog box.

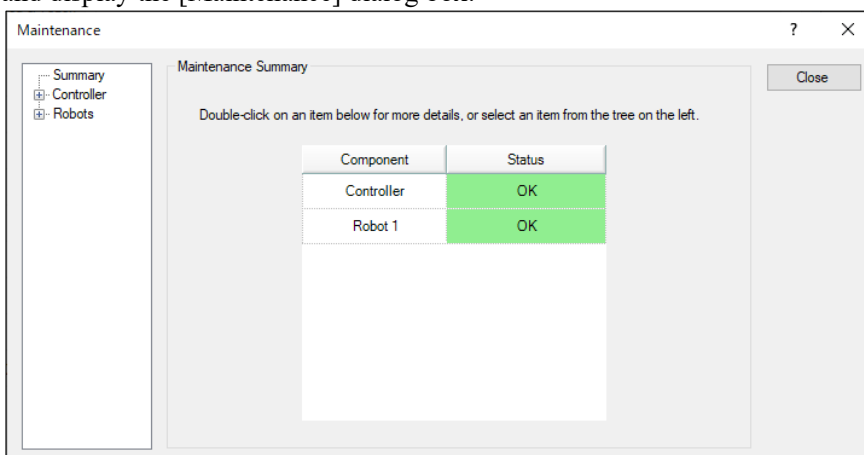

- (3) Select “General” or specify the axis from the tree to display information of the target parts.

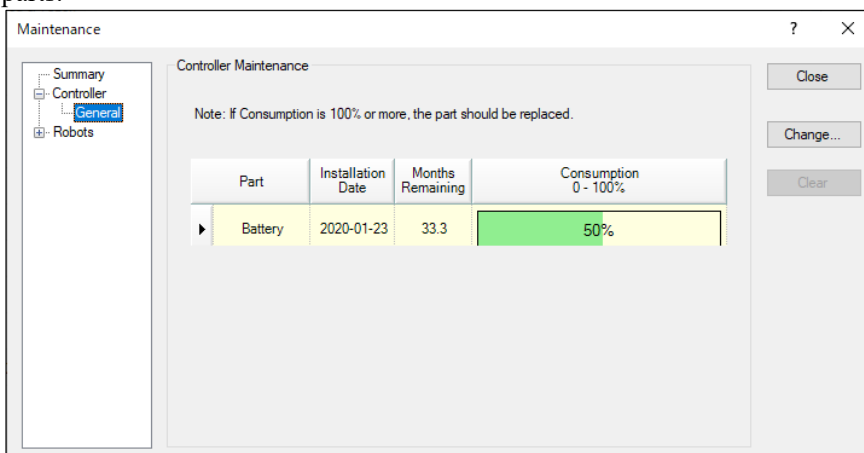

The recommended replacement time for the battery is calculated based on the battery capacity and the Manipulator ON time. The battery may run out if it passes the recommended replacement time.



The recommended replacement time for the grease is calculated based on the elapsed days since date of grease up. The replacement time may be shorter or longer depending on usage condition, such the load applied on the robot.



The recommended replacement time for the parts (timing belts, motors, reduction gear units, and ball screw spline unit) is when it reaches the L10 life (time until 10% failure probability). In the [Maintenance] dialog box, the L10 life is displayed as 100%.

4.2.2 How to Edit the Maintenance Information

The configured Maintenance information can be edited in the EPSON RC+.

- (1) Select the EPSON RC+ 7.0 menu-[Tools]-[Controller] to display the [Controller Tools] dialog box.
- (2) To edit the Maintenance information, display the [Maintenance] dialog box.
- (3) Select “General” or specify the axis from the tree to display information of the target parts.
- (4) Select the alarm to be changed and click the <Change> button.
- (5) Display the [Change Alarm] dialog box and enter any of the following.

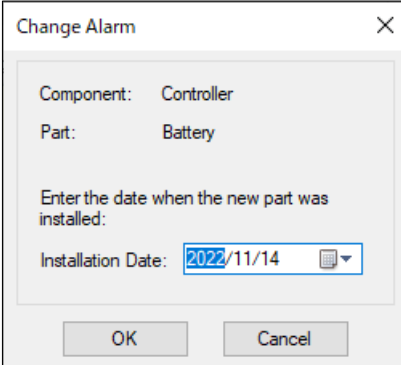

Purchase or replacement date of the battery

Date of grease up

Purchase or replacement date of the timing belt

Purchase or replacement date of the motor

Purchase or replacement date of the reduction gear unit

Purchase or replacement date of the ball screw spline unit

- (6) Click the <OK> button and change the specified alarm information.



The offset can be set for the consumption rate of already installed parts. Follow the steps below to calculate a rough offset setting value.

1. Measure the usable months for the past operation by “HealthRBAAnalysis” command.
2. Confirm the past Motor ON time in the controller status viewer.
3. Calculate a rough offset value with the following formula.

$$\text{Offset} = 100 \times \frac{\text{Motor On time}}{24 \times 30.4375 \times \text{Usable months}}$$

For details, refer to the *EPSON RC+ 7.0 SPEL+ Language Reference*.

4.2.3 Alarm Notifying Method

The Manipulator status becomes warning and displays warning message if any parts required to perform replacement or grease up.

For details, refer to the following manual.

Status Code / Error Code List

The alarm notifying method can be configured by the output bit of the Remote I/O.

The Remote I/O can be configured in the EPSON RC+ 7.0- [Setup] - [System Configuration] - [Controller] - [Remote Control].

For details, refer to *EPSON RC+ 7.0 User's Guide 12.1 Remote I/O*.

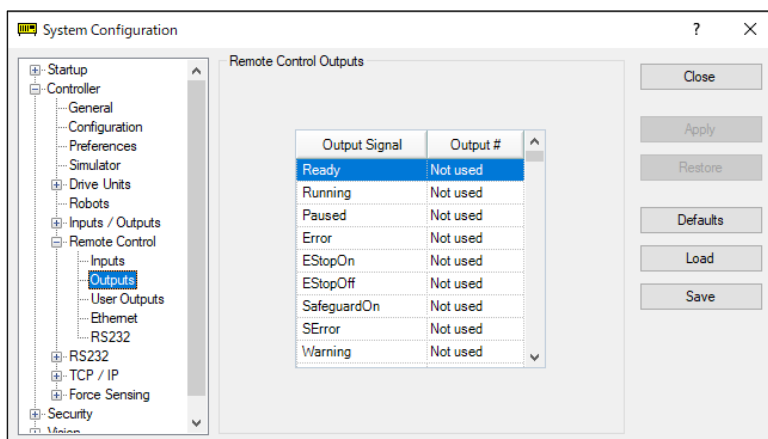

The controller enters the warning state if an alarm occurs.

Alarm1 to Alarm9 set in the output bit of the remote I/O monitor the occurrence of warnings every 5 minutes.

The alarm occurrence and output timing on the controller are different. It may be output to the remote I/O up to 5 minutes after the alarm is occurred on the controller.

4.2.4 How to Cancel the Alarm

An alarm occurs when the consumption rate of the parts reaches 100%.



The alarm cannot be canceled by executing the Reset command or restarting the controller. The alarm can be canceled by the following method.

- Operation from [Maintenance] dialog box of the EPSON RC+ 7.0
- HealthCtrlReset Command
- HealthRBReset Command

Refer to “4.2.2 How to Edit the Maintenance Information” to change the alarm information in the same steps.

5. Backup and Restore

5.1 What is the Backup Controller Function

The Manipulator configuration set by EPSON RC+ 7.0 can be stored with the “Backup Controller” function.

The Manipulator settings can be restored easily using the data previously stored with “Backup Controller” after a configuration mistake or Manipulator problem.

Be sure to execute “Backup Controller” before changing the Manipulator setup, before maintenance, or after teaching.

For some problems, backup may not be available before maintenance has to be performed. Be sure to backup the data after making changes, before problems occur.



“Controller Status Storage” is one of the T-B series functions. It saves the Controller setup data same as “Backup Controller.”

There data can be used as the backup data at restoring.

The methods for “Controller Status Storage” are as follows:

A: “Controller status storage to USB memory”

For details, refer to T-B series Manual “*T3-B T6-B Manipulator 8. Memory Port*”.

B: “Export Controller Status function” in EPSON RC+ 7.0.

For details, refer to “*EPSON RC+ 7.0 User’s Guide 5.10.10 [Import] Command (Project Menu)*”.

5.2 Backup Data Types

The table below shows the files created with “Backup Controller”.

File Name	Overview	
Backup.txt	Information file for restore	File including information for restoring the Manipulator.
CurrentMnp01.PRM	Manipulator parameters	Stores information such as ToolSet.
InitFileSrc.txt	Initial configuration	Stores various Manipulator parameters.
MCSys01.MCD	Manipulator configuration	Stores connected Manipulator information.
All the files related to Project	Project related	All the project files transferred to the Controller. Includes program files when EPSON RC+ 7.0 is configured to transfer source code to the Controller.
GlobalPreserves.dat	Global Preserve variables	Saves values of Global Preserve variables.
WorkQueues.dat	WorkQue information	Saves information of Queues information of the WorkQue.

5.3 Backup

Backup the Manipulator status from the EPSON RC+ 7.0.

- (1) Select the EPSON RC+ 7.0 menu-[Tools]-[Controller] to display the [Controller Tools] dialog box.

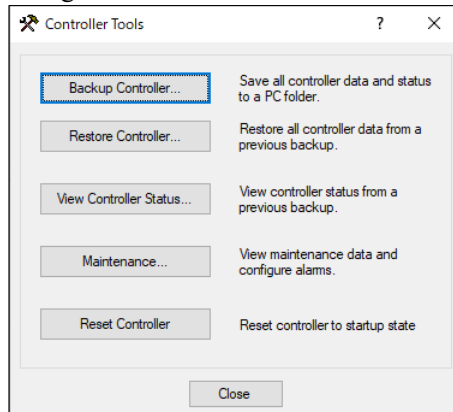

- (2) Click the <View Controller Status> button to open the [Browse For Folder] dialog.

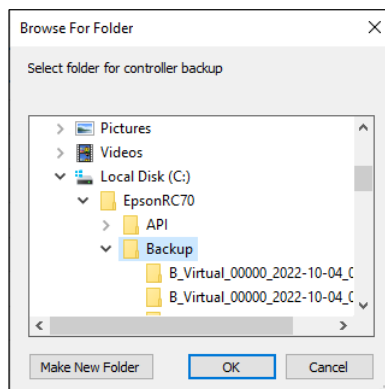

- (3) Specify the folder to save the backup data. Create a new folder if desired.
- (4) Click the <OK> button. A folder is created in the specified folder containing the backup data with a name in the following format.
- B_T_serial number_date status was saved
 → Example: B_T_12345_2016-04-03_092941



CAUTION

- Do not edit the backup files. Otherwise, operation of the robot system after data restoration to the Manipulator is not assured.

5.4 Restore

Restore the Manipulator status from the EPSON RC+ 7.0.

 CAUTION	<ul style="list-style-type: none"> ■ Make sure that the data used for restoring was saved previously for same Manipulator. ■ Do not edit the backup files. Otherwise, operation of the robot system after data restoration to the Manipulator is not assured.
---	---

(1) Select the EPSON RC+ 7.0 menu-[Tools]-[Controller] to display the [Controller Tools] dialog box.

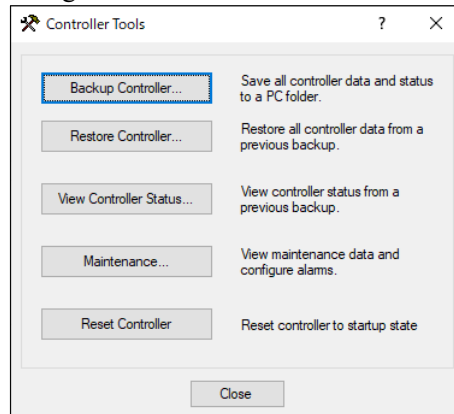

(2) Click the <Restore Controller...> button to display the [Browse For Folder] dialog.

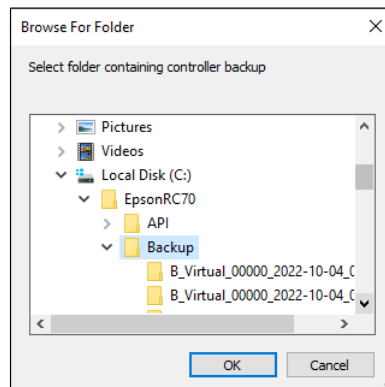

(3) Specify the folder to save the backup data.

B_T_ serial number_ date status was saved

→ Example: B_T_12345_2016-04-03_092941

NOTE  Controller status backup to USB memory function can also be specified for restore. Specify the following folder

- (4) Click the <OK> button to display the [Restore Controller] dialog.

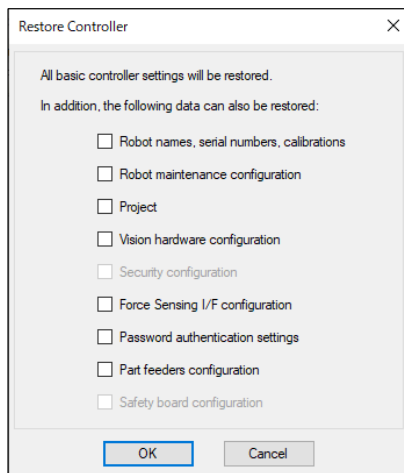

Robot name, serial #, calibration

This checkbox allows you to restore the robot (Manipulator) name, Manipulator serial number, Hofs data, and CalPIs data. Make sure that the correct Hofs data is restored. If the wrong Hofs data is restored, the Manipulator may move to wrong positions.

This is not selected by the default setting.

Robot maintenance configuration

This checkbox allows you to restore the robot alarm related files.

For details, refer to “4. Alarm”.

This is not selected by the default setting.

Check this checkbox when restoring a backup data which is retrieved while the EPSON RC+ 7.0 menu-[Setup]-[System Configuration]-[Controller]-[Preferences]-[Enable robot maintenance data] checkbox is checked. If not checked, the maintenance data will not be reflected.

Project

This checkbox allows you to restore the files related to projects.

This is not selected by the default setting.

When a project is restored, the values of Global Preserve variables are loaded.

For details about Global Preserve variable backup, refer to the following manual.

EPSON RC+ 7.0 User's Guide 5.11.10 [Display Variables] Command (Run Menu).

Vision hardware configuration

This checkbox allows you to restore the vision hardware configuration.

For details, refer to the following manual.

EPSON RC+ 7.0 option Vision Guide 7.0.

This is not selected by the default setting.

Security configuration

This checkbox allows you to restore the security configuration.

For details, refer to the following manual.

EPSON RC+ 7.0 User's Guide 15. Security.

This is not selected by the default setting.

Force Sensing I/F configuration

This checkbox allows you to restore the Force Sensing I/F configuration.

This is not selected by the default setting.

This function is not supported for T-B series Manipulator.

Password authentication settings

This checkbox allows you to restore the setting of authentication for PC connection. The authentication password for PC connection and the setting to disable connection authentication are restored.

This is not selected by the default setting.

Part feeders configuration

This check box allows you to restore the communication settings, etc. of the part feeders.

For details, refer to the following manual.

EPSON RC+ 7.0 Option Part Feeding 7.0 Introduction & Software

This is not selected by the default setting.

Safety board configuration

This checkbox allows you to restore the setting of the safety function.

For details, refer to the following manual.

Robot Controller Safety Function Manual

This function is not supported for T-B series Manipulator.

Click the <OK> button to restore the system information.



Restore the system configuration saved using Backup Controller only for the same system. When different system information is restored, the following warning message appears.

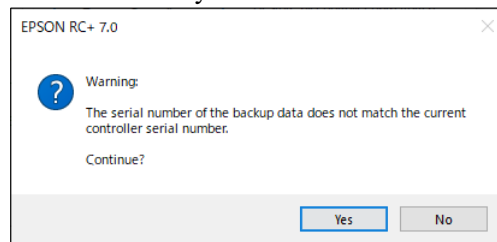

Click the <No> button (do not restore data) except for special situations such a manipulator replacement.



When restoring the backup including the robot information other than T-B series, an error occurs.



You cannot restore the backup including T-B series robot created in the virtual controller of EPSON RC+ 7.0 to the T-B series robot.

6. Firmware Update

This chapter describes the firmware upgrade procedure and data file initialization when firmware or manipulator configuration errors cause Manipulator startup or operation failure.

6.1 Updating Firmware

Firmware (software stored in non-volatile memory) and data files necessary to control the Manipulator are pre-installed in the Manipulator. Controller configuration set from EPSON RC+ 7.0 is always saved in the Manipulator.

Firmware is supplied by CD-ROM as needed. Please contact the supplier of your region for information.

You must use a PC running EPSON RC+ 7.0 connected to a Manipulator with USB to update the Manipulator firmware. Firmware cannot be updated with an Ethernet connection.

NOTE  When installing the firmware Ver.7.5.0.x or later, be sure to use the PC which EPSON RC+ 7.0 Ver.7.5.0 or later is installed.

6.2 Firmware Upgrade Procedure

The firmware upgrade procedure is described as follows:



CAUTION

- DO NOT unplug the USB cable, or turn OFF the Manipulator or the development PC during upgrade of the firmware. Doing so may result in malfunction of the robot system.

- (1) Connect the development PC and the Manipulator with a USB cable.
(the firmware cannot be changed with an Ethernet connection.)
- (2) Turn ON the Manipulator.
(Do not start the development software EPSON RC+ 7.0 until the firmware upgrade is completed.)
- (3) Insert the “firmware CD-ROM” in the development PC CD-ROM drive.
- (4) Execute “CtrlsetupT.exe”. The following dialog appears.

- (5) Select the <Upgrade> option button and click the <Next> button.

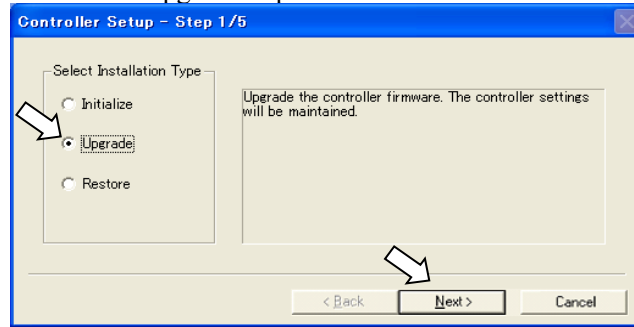

- (6) Make sure that the development PC is connected to the Manipulator with a USB cable and Click the <Next> button.

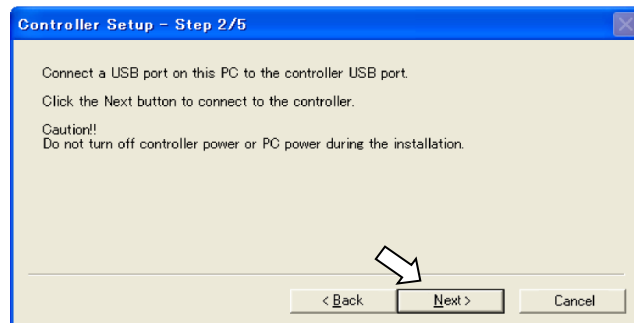

- (7) Check the current firmware version and the new firmware version and click the <Install> button.

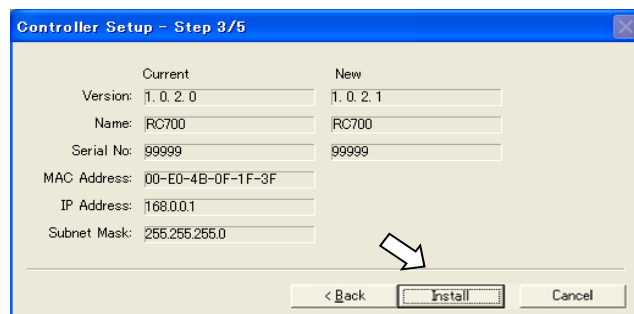

- (8) The firmware upgrade starts. It takes several minutes to complete.

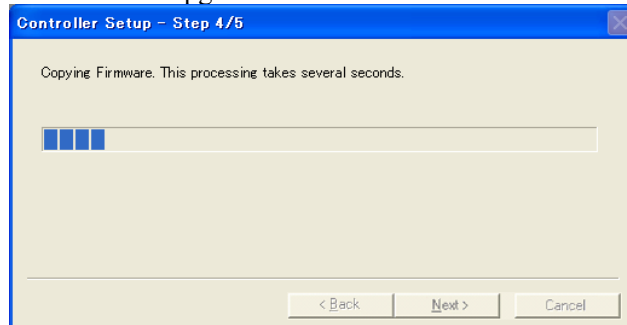

(9) The data file will continue to be transferred.

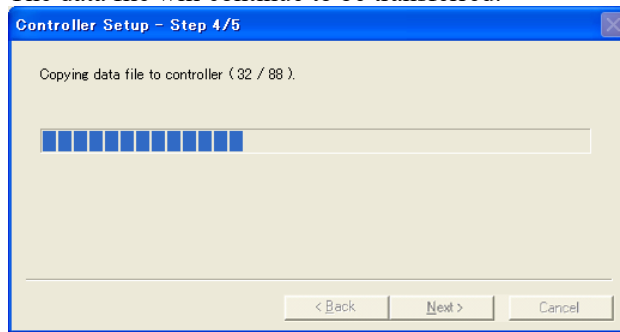

(10) The following dialog appears.

Click the <Next> button to reboot the Manipulator.

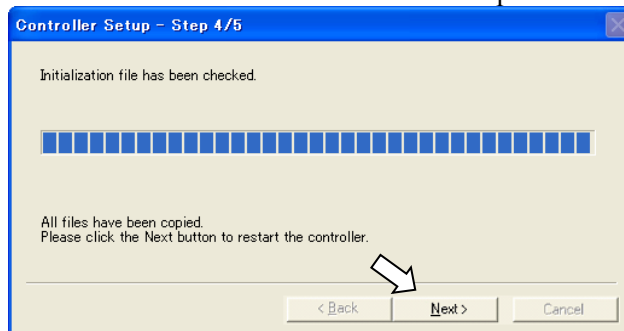

(11) The following dialog appears after the Controller reboot.

Click the <Finish> button.

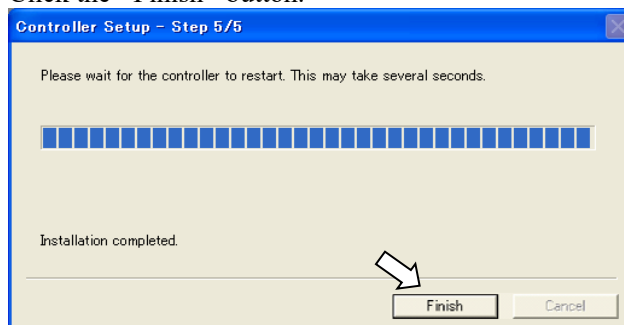

The firmware upgrade is complete.

NOTE

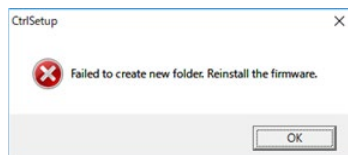

When you install the firmware (Ver.7.4.0.2 or later) on the controller which the firmware (before Ver.7.4.0.2) has been installed, the following message is displayed.



When the message is displayed, re-install the firmware.

6.3 Manipulator Recovery

If the Manipulator becomes inoperable, use the procedures described in this section to recover.

 **NOTE** Controller Backup is recommended for easy recovery of the Controller operation. For details of Controller Backup, refer to “5. Backup and Restore”.

6.4 Firmware Initialization Procedure

The firmware initialization procedures are described in this section.

 CAUTION	<ul style="list-style-type: none"> ■ DO NOT unplug the USB cable, or turn OFF the Manipulator or the development PC during upgrade of the firmware. Doing so may result in malfunction of the robot system.
---	--

- (1) Connect the development PC and the Manipulator with a USB cable.
(the firmware cannot be changed with an Ethernet connection.)
- (2) Turn ON the Manipulator.
(Do not start the development software EPSON RC+ 7.0 until the firmware upgrade is completed.)
- (3) Insert the “firmware CD-ROM” in the development PC CD-ROM drive.
- (4) Execute “CtrlsetupT.exe”.
- (5) Select the <Initialize> option button and click the <Next> button.

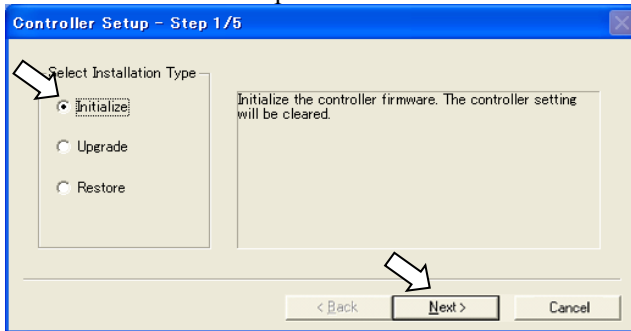

- (6) Make sure that the development PC is connected to the Controller with a USB cable and Click the <Next> button.

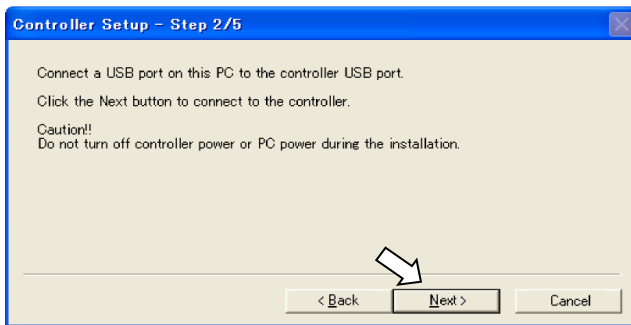

- (7) Check the version information and click the <Install> button.

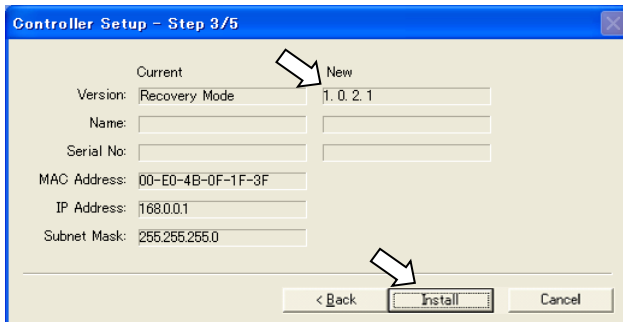

- (8) Firmware and data file transfer starts. It takes several minutes to complete.

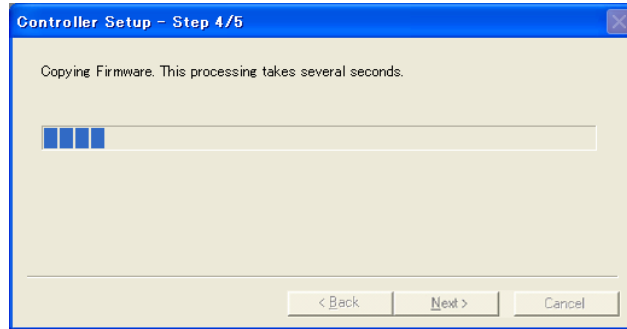

- (9) The following dialog appears.

Click the <Next> button to reboot the Manipulator.

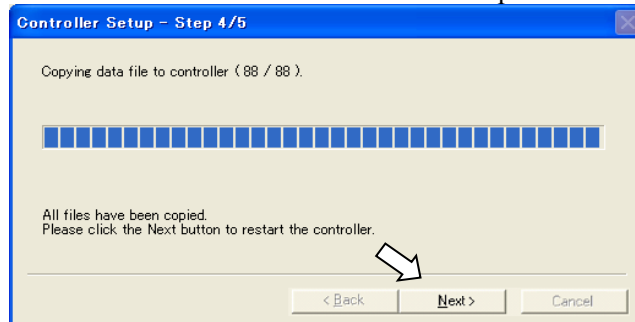

- (10) The following dialog appears after the Controller reboot.

Click the <Finish> button.

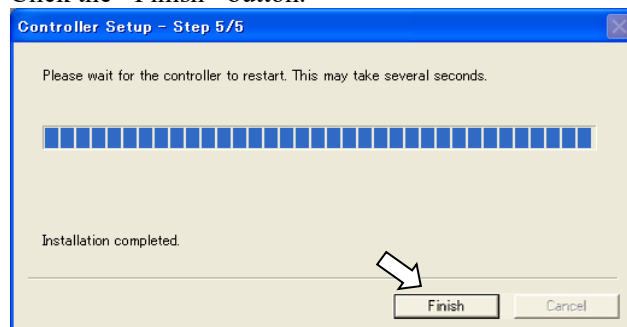

The firmware upgrade is completed.

Start EPSON RC+ 7.0 and restore the Controller settings.

For details of Controller Backup, refer to "5. Backup and Restore".

NOTE When you install the firmware (Ver.7.4.0.2 or later) on the controller which the firmware (before Ver.7.4.0.2) has been installed, the following message is displayed.

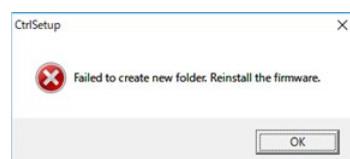

When the message is displayed, re-install the firmware.

6.5 Adding Confirmation Steps by Strengthening Security of EtherNet Connection

From the following firmware version password authentication is required when connecting Controllers and PCs to a global accessible network.

F/W: Ver.7.4.58.x

In the following cases, connections of EtherNet (PC) connector and Remote Ethernet are not available.

Controller IP address is set to global IP address

Firmware version is Ver.7.4.58.x or later

EPSON RC+7.0 is Ver.7.4.7 or before

When the Controller firmware is updated under the following conditions, additional steps to confirm whether to continue the firmware update may be execute depending on the configuration settings of the Controller. (step 3 or later shown below)

Controller IP address is set to global IP address

Firmware version to be installed is 7.4.8.x or later

The following describes the steps to confirm whether to continue the firmware update.

- (1) Insert the “firmware CD-ROM” in the development PC CD-ROM drive.
- (2) Execute “CtrlsetupT.exe”.
- (3) Controller Setup window is displayed.

Select the <Upgrade> option button and click the <Next> button.

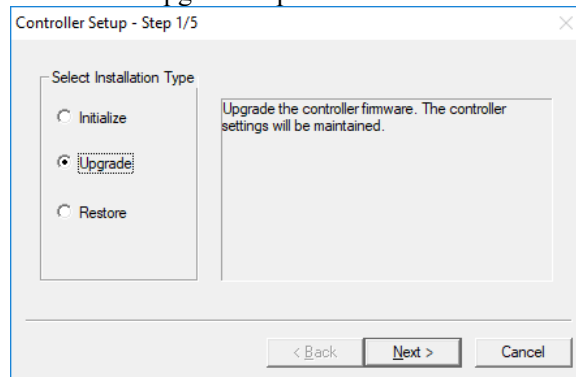

(4) Step 2 window is displayed.

Click the <Next> button.

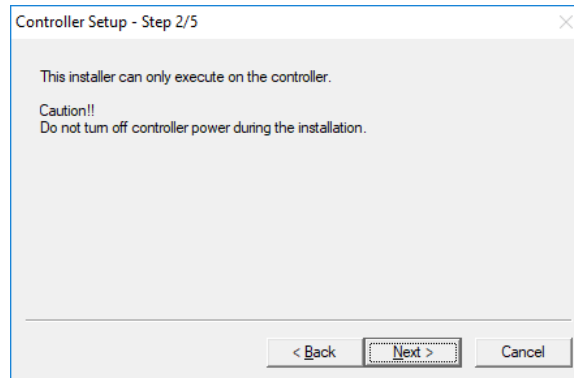

(5) Step 3 window is displayed.

(5)-1 When the steps to confirm whether to continue the firmware update is not executed:

Step 3 window is displayed.

Follow the instructions on the window and install the firmware.

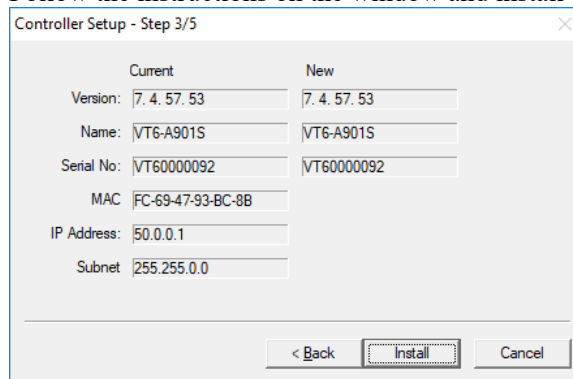

(5)-2 When the steps to confirm whether to continue the firmware update is executed:

The following window is displayed.

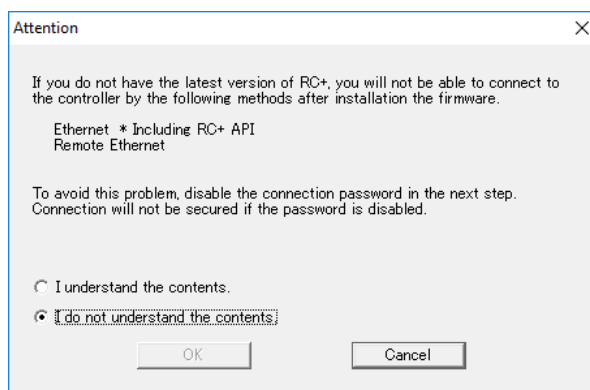

When the <I understand the contents> button is selected, the <OK> button will be enabled.

When the <OK> button is clicked, Step3 window is displayed. Go to the step (6).

When the <Cancel> button is clicked, Step3 window is displayed. The [Disable connection password] check box and the <Install> button will be grayed out and cannot be selected.

(6) Step 3 window is displayed.

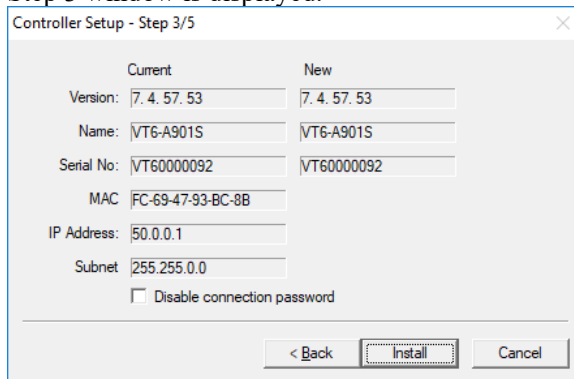

(6)-1 If the [Disable connection password] check box is selected, connection authentication after updating the firmware is disabled.

(6)-2 If the <Install> button is clicked, the confirmation window is displayed.

When the [Disable connection password] check box is selected:

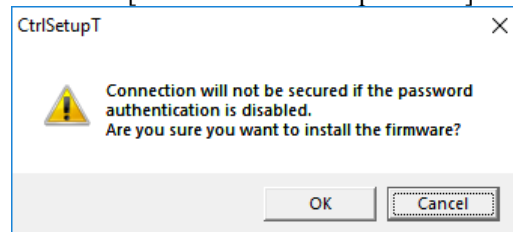

When the [Disable connection password] check box is not selected:

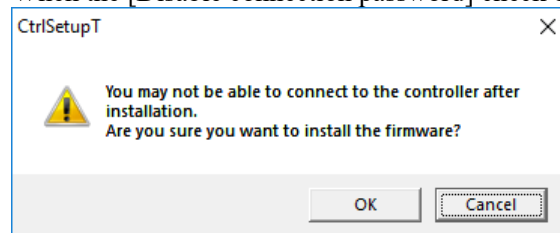

When the <OK> button is clicked, Step 4 window is displayed. Go to the step (7).

When the <Cancel> button is clicked, the window is closed.

(7) Firmware installation starts.

When the firmware is installed, click the <Next> button. Reboot the Controller.

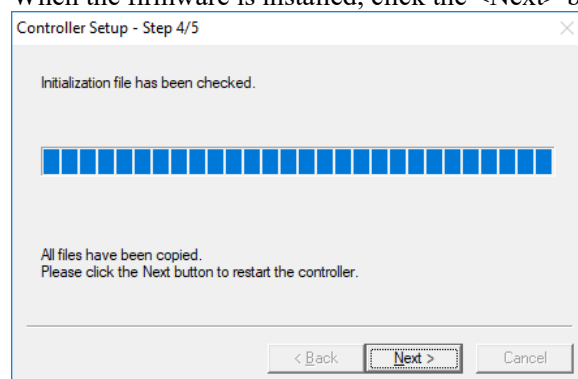

- (8) When the Controller is rebooted, the following window is displayed.
Confirm that the firmware is installed.
Click the <Finish> button.

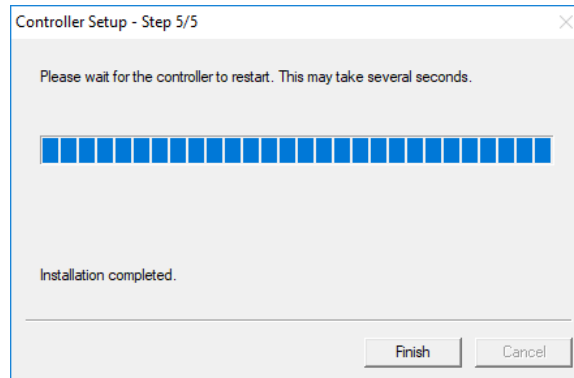

7. Covers

All procedures for removing and installing covers in maintenance are described in this chapter.



WARNING

- Do not connect or disconnect the motor connectors while the power to the robot system is turned ON. Connecting or disconnecting the motor connectors with the power ON is extremely hazardous and may result in serious bodily injury as the Manipulator may move abnormally, and also may result in electric shock and/or malfunction of the robot system.
- To shut off power to the robot system, disconnect the power plug from the power source. Be sure to connect the AC power cable to a power receptacle. DO NOT connect it directly to a factory power source.
- Before performing any replacement procedure, turn OFF the robot system and related equipment, and then disconnect the power plug from the power source. Performing any replacement procedure with the power ON is extremely hazardous and may result in electric shock and/or malfunction of the robot system.
- Be careful not to get any foreign substances in the Manipulator, connectors, and pins during maintenance. Turning ON the power to the robot system when any foreign substances exist in them is extremely hazardous and may result in electric shock and/or malfunction of the robot system.

T3-B

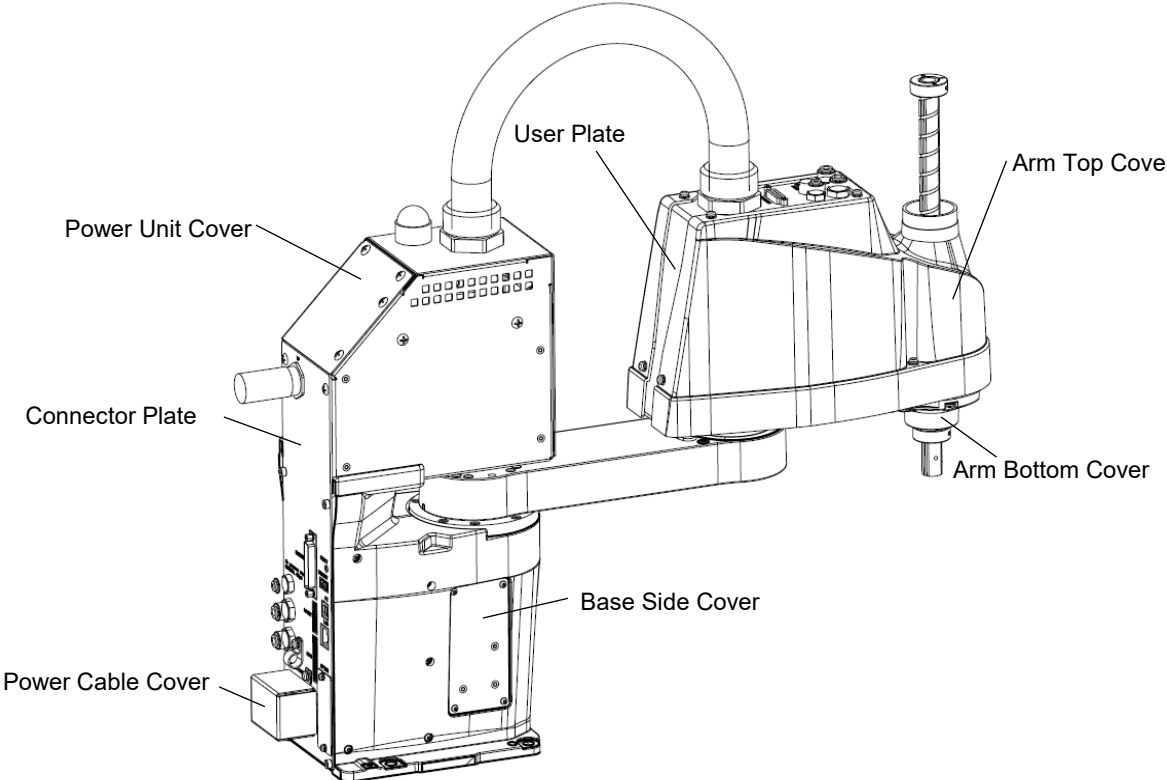

T6-B

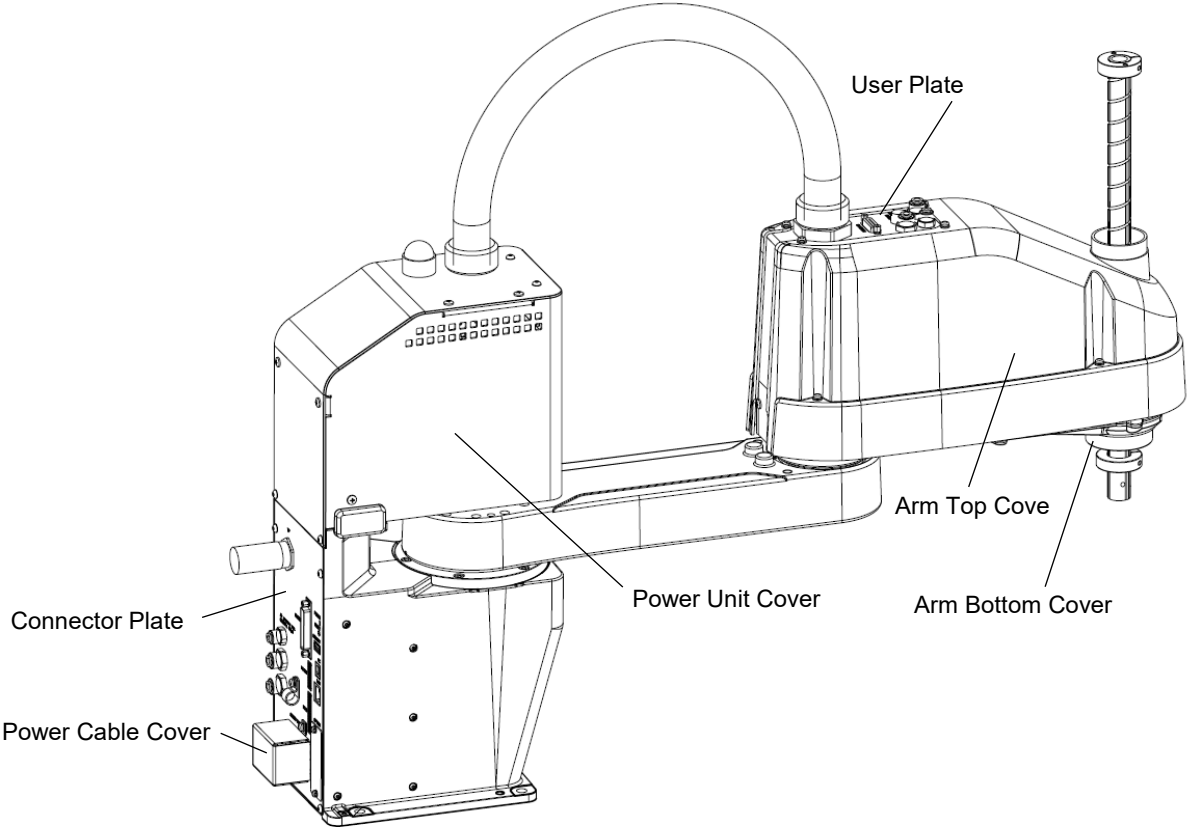

7.1 Arm Top Cover



CAUTION

- Do not remove the arm top cover forcibly. Removing the cover forcibly may result in damage to the cables, disconnection, and/or contact failure.
- When installing the cover, be careful not to allow the cables to interfere with the cover mounting and do not bend these cables forcibly to push them into the cover. Unnecessary strain on cables may result in damage to the cables, disconnection, and/or contact failure. When routing the cables, observe the cable locations after removing the cover. Be sure to place the cables back to their original locations.

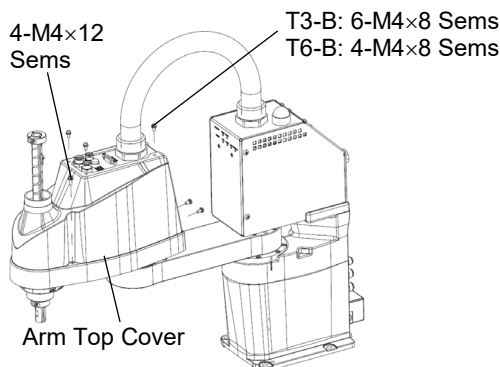

Arm Top Cover Removal

Unscrew the arm top cover mounting bolts, and then lift the cover.

NOTE



Be careful of user wires and tubes when removing the cover.

Arm Top Cover Installation

Put the arm top cover to the arm and secure with the arm top cover mounting bolts.

After securing the arm top cover, make sure that the lower limit mechanical stop is not touching the cylindrical part of the arm top cover.

NOTE



For tightening hexagon socket head cap bolts, refer to “2.4 Tightening Hexagon Socket Head Cap Bolts”.

7.2 Arm Bottom Cover

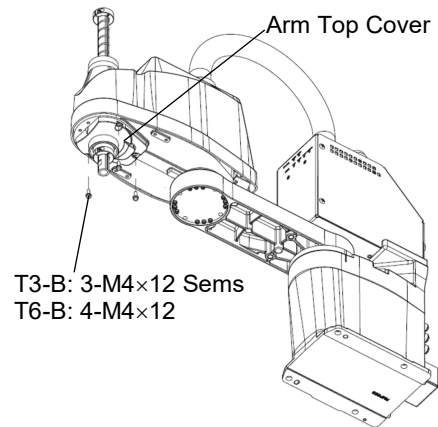

Unscrew the arm bottom cover mounting bolts and then remove the cover.



Be careful of the end effector. When the end effector is installed, the arm bottom cover may not be removed from the shaft.

When you replace the ball screw spline unit, you need to remove the end effector to remove the arm bottom cover completely.

When you can work (maintenance, inspection) without removing the cover completely, move the shaft to the lower limit and lower the arm bottom cover.



For tightening hexagon socket head cap bolts, refer to “2.4 Tightening Hexagon Socket Head Cap Bolts”.

7.3 Power Cable Cover

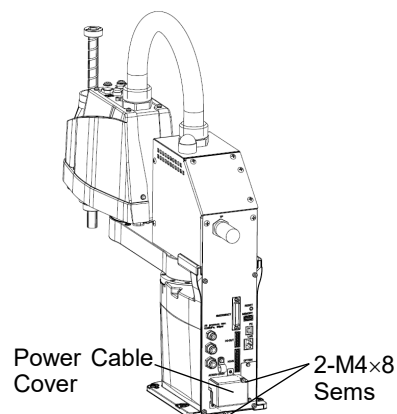

Unscrew the power cable cover mounting bolts and then remove the power cable cover.

7.4 Connector Plate



- Do not remove the connector plate forcibly. Unnecessary strain on cables may result in damage to the cables, disconnection, and/or contact failure.
- When installing the connector plate, be careful not to allow the cables to interfere with the plate mounting and do not bend these cables forcibly to push them into the cover. Unnecessary strain on cables may result in damage to the cables, disconnection, and/or contact failure. When routing the cables, observe the cable locations after removing the cover. Be sure to place the cables back to their original locations.

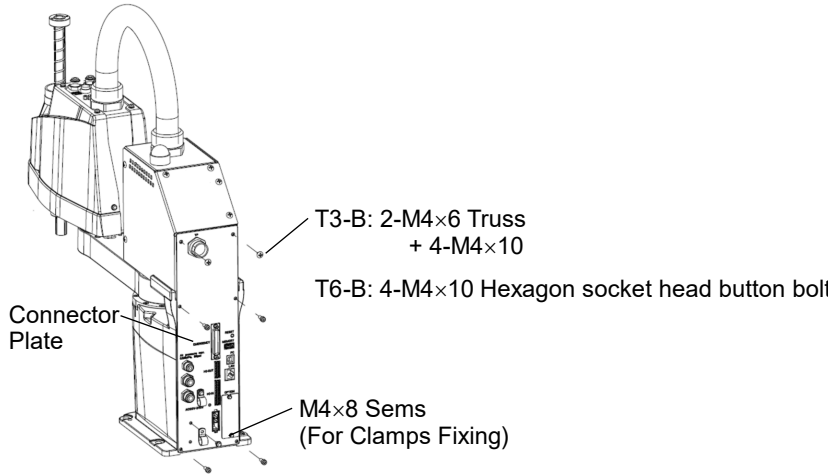

Connector Plate Removal

- (1) Remove the Power Cable Cover.
Reference 7.3 Power Cable Cover

- (2) Remove power cable clamp and then remove power cable connector.

NOTE When removing the power cable connector, pull it out with pushing clips on both side of the connector.

(3) NOTE Unscrew the power cable cover mounting bolts and then remove the power cable cover.

Some fixed bolts are the same as power unit cover fixing bolts.

NOTE Position of the fittings and size of the connector plate are different between T6-B and T3-B. Position and size of screws is the common. The above illustration is T3-B.

Connector Plate (1) Put the connector plate to the base and secure using the mounting bolts.

Installation Hexagon socket head cap button bolt

Tightening torque: 2.0 ± 0.1 N·m

(2) Connect power cable connector and install power cable clamp.

(3) Mount the power cable cover.

Reference *7.3 Power Cable Cover*

NOTE



When installing the connector plate, be careful of the following.

Prevent the air tube from bending sharply inside the manipulator. Also, do not block the air flow.

If there is a kink in the air tube, air flow is blocked while the manipulator is operating and may cause a trouble.



7.5 Power Unit Cover

T3-B

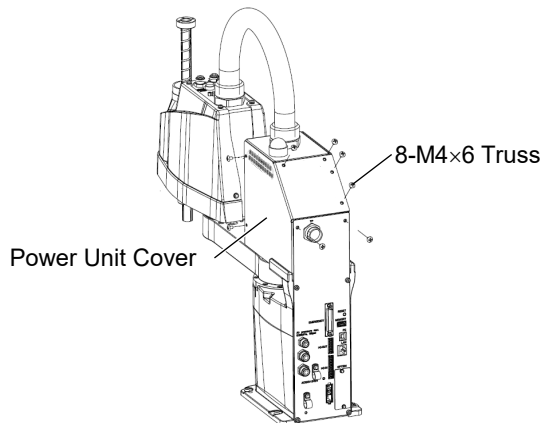

NOTE



Unscrew the power unit cover mounting bolts, and then remove the power unit cover.
Some fixed bolts are the same as power unit cover fixing bolts.

T6-B

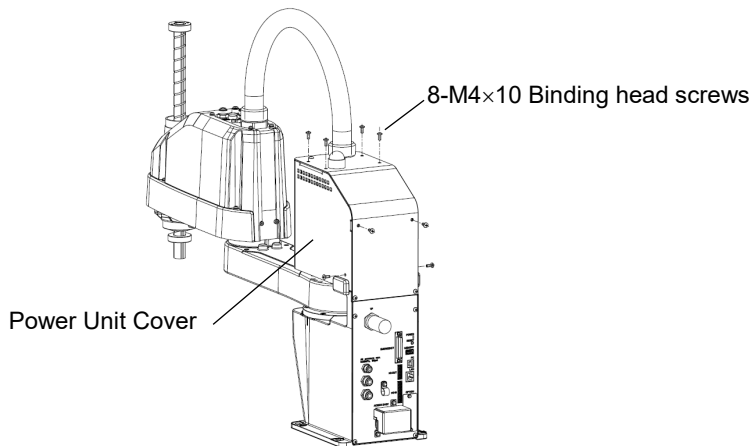

NOTE



Unscrew the power unit cover mounting bolts, and then remove the power unit cover.
After unscrewing the bolts, make sure to pull the power unit cover to the front of the robot and remove it.

7.6 Base Side Cover



- Do not remove the base side cover forcibly. Unnecessary strain on cables may result in damage to the cables, disconnection, and/or contact failure.
- When installing the base side cover, be careful not to allow the cables to interfere with the plate mounting and do not bend these cables forcibly to push them into the cover. Unnecessary strain on cables may result in damage to the cables, disconnection, and/or contact failure. When routing the cables, observe the cable locations after removing the cover. Be sure to place the cables back to their original locations.

T3-B

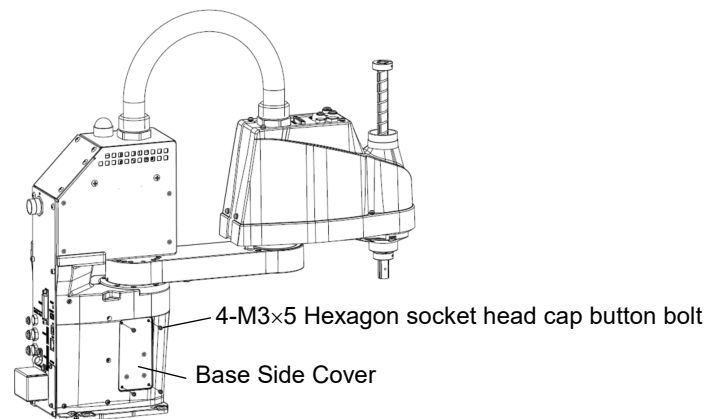

Unscrew the base side cover mounting bolts, and then remove the base side cover.



T6-B

There is no base side cover.

7.7 User Plate



- Do not remove the user plate forcibly. Removing the user plate forcibly may result in damage to the cables, disconnection, and/or contact failure.
- When installing the user plate, be careful not to allow the cables to interfere with the plate mounting and do not bend these cables forcibly to push them into the cover. Unnecessary strain on cables may result in damage to the cables, disconnection, and/or contact failure. When routing the cables, observe the cable locations after removing the connector plate. Be sure to place the cables back to their original locations.

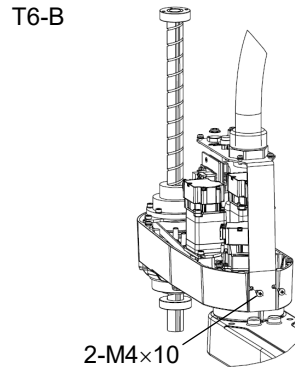
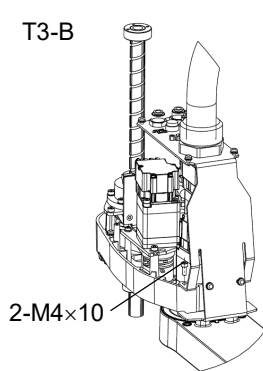

User Plate Removal

- (1) Remove the arm top cover.
Reference 7.1 Arm Top Covers
- (2) Cut off the wire tie binding the brake cable and then remove the connector of break release switch.

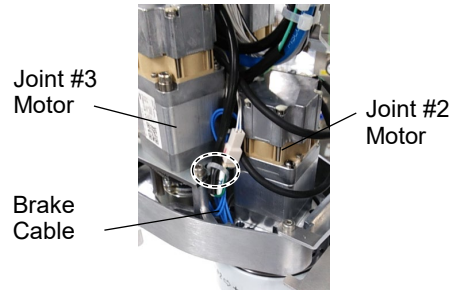

- (3) Unscrew the user plate mounting bolts and remove the plate.

User Plate Installation

- (1) Put the user plate to the arm and secure using the mounting bolts.
- (2) Bind the internal cables with a wire tie as worked in the removal procedure (2).
- (3) Mount the arm top cover.
Reference 7.1 Arm Top Covers

NOTE For tightening hexagon socket head cap bolts, refer to “2.4 Tightening Hexagon Socket Head Cap Bolts”.

8. Cable



WARNING

- Do not connect or disconnect the connectors while the power to the robot system is turned ON. Connecting or disconnecting the motor connectors with the power ON is extremely hazardous and may result in serious bodily injury as the Manipulator may move abnormally, and also may result in electric shock and/or malfunction of the robot system.
- To shut off power to the robot system, disconnect the power plug from the power source. Be sure to connect the AC power cable to a power receptacle. DO NOT connect it directly to a factory power source.
- Before performing any replacement procedure, turn OFF the robot system and related equipment, and then disconnect the power plug from the power source. Performing any replacement procedure with the power ON is extremely hazardous and may result in electric shock and/or malfunction of the robot system.
- Be careful not to get any foreign substances in the Manipulator, connectors, and pins during maintenance. Turning ON the power to the robot system when any foreign substances exist in them is extremely hazardous and may result in electric shock and/or malfunction of the robot system.



CAUTION

- Be sure to connect the cables properly. Do not allow unnecessary strain on the cables. (Do not put heavy objects on the cables. Do not bend or pull the cables forcibly.) Unnecessary strain on cables may result in damage to the cables, disconnection, and/or contact failure.

8.1 Replacing Cable Unit

	Name		Quantity	NOTE
Maintenance part	Cable Unit		1	T3-B: 2207936 T6-B: 2207939
Tools	Hexagonal wrench	Width across flats: 2 mm	1	For M3 button bolt
		Width across flats: 2.5 mm	1	For M3 screw, M4 button bolt
		Width across flats: 3 mm	1	For M4 screw
	Spanner	Width across flats: 5 mm	1	Hand I/O connector removal
	Nut screwdriver	Width across flats: 5 mm	1	
	Spanner	Width across flats: 41 mm	1	Removal
	Torque wrench		1	
	Cross-point screwdriver (No. 2)		1	For cross-recessed screw
Nippers		1	For cutting wire tie	
Material	Wire tie		-	
	adhesive		-	LOCTITE268

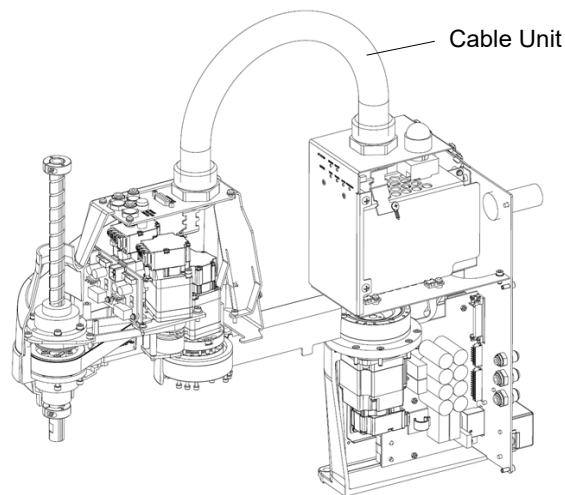

(Illustration: T3-B 401S)

 <p>CAUTION</p>	<ul style="list-style-type: none">■ If the connectors have been disconnected during the replacement of the cable unit, be sure to reconnect the connectors to their proper positions. Improper connection of the connectors may result in improper function of the robot system. For details on the connections, refer to “3. Manipulator Structure”.■ When installing the cover, be careful not to allow the cables to interfere with the cover mounting and do not bend these cables forcibly to push them into the cover. Unnecessary strain on cables may result in damage to the cables, disconnection, and/or contact failure. When routing the cables, observe the cable locations after removing the cover. Be sure to place the cables back to their original locations.■ Be sure to connect the cables properly. Do not allow unnecessary strain on the cables. (Do not put heavy objects on the cables. Do not bend or pull the cables forcibly.) Unnecessary strain on cables may result in damage to the cables, disconnection, and/or contact failure.
--	--

NOTE



A brake is mounted on the Joint #3 motor to prevent the shaft from lowering down due to the weight of the end effector while the power to the Manipulator is OFF or while the motor is in OFF status (MOTOR OFF).

Refer to removal steps (1) to (3) to move the shaft down to its lower limit before the replacement procedure.

Cable Unit Removal

- (1) Turn ON the Manipulator and change the motor to OFF status (MOTOR OFF).
- (2) Press and hold the brake release switch to let the shaft down. Be sure to keep enough space and prevent the end effector hitting any peripheral equipment.

The brake release switch affects only Joint #3. When the brake release switch is pressed, the Joint #3 brake is released.

Be careful of the shaft falling while the brake release switch is being pressed because the shaft may be lowered by the weight of the end effector.

- (3) Turn OFF the Manipulator.
- (4) Remove the power unit cover.

Reference: 7.5 Power Unit Cover

- (5) Remove the ground wire that secured on the case side cable fixing plate.
- (6) Cut off the wire tie binding the cables in the Base side.
- (7) Remove the connector plate.

Reference: 7.4 Connector Plate

- (8) Remove the following parts that connected to the connector plate (inside).

Air tube
TP connector

- (9) T3-B : Remove the base side cover.

Reference: 7.6 Base Side Cover

T6-B : Remove the connector of regenerative resistor junction cable.

Unscrew the mounting bolts of the joint #1 AMP board plate and the regenerative resistor plate.

Mounting bolts: 4-M4×8 Sems

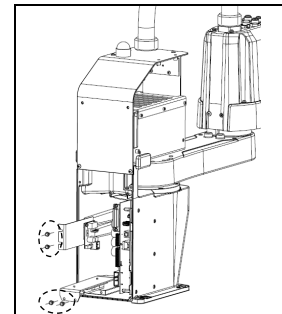

- (10) Remove the connector of AMP board.

A: Power cable connector
B: Signal cable connector
C: Motor connector

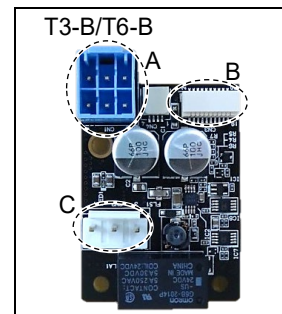

- (11) Unscrew CPU/DPB board mounting screws.
Hexagon socket head cap button bolt: 5-M3×5
- Remove CPU/DPB board from a base.

NOTE  Radiation sheet is attached on the back of CPU/DPB board. Be careful not to lose or break it.

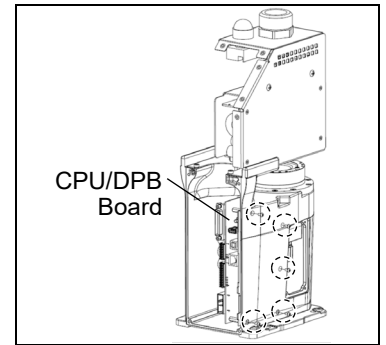

- (12) Remove the CPU/DPB board connector.
- A: Power connector (IN/OUT ×1 for each)
- B: Power cable connector (×1)
- C: Signal cable connector
- D: Hand I/O connector
- E: LED connector
- F: Regenerative resistor 1 (T6-B only)
- G: Regenerative resistor 2 (T6-B only)
- H: Battery connector

NOTE  Remember the cable layout for reconnecting the cables correctly after replacement.

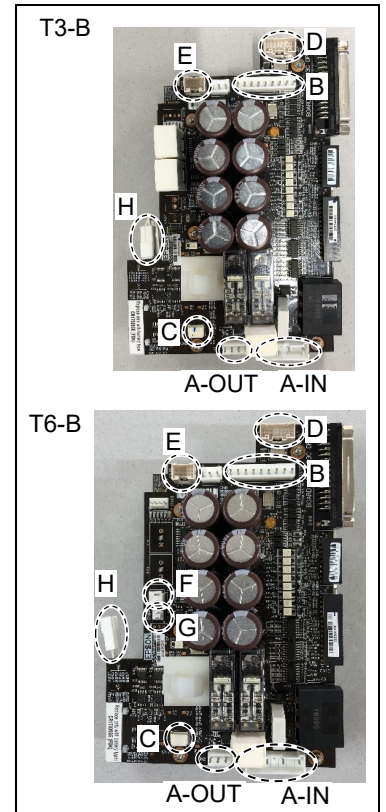

- (13) Remove the arm top cover.
Reference: 7.1 *Arm Top Cover*
- (14) Remove the user plate.
Reference: 7.7 *User Plate*

- (15) Remove the connector of the Joint # 2, 3, 4 motor unit and the connector of the AMP board.

Motor Unit

Signal cable connector (IN/OUT ×1 for each)

NOTE  Signal cable for joint #4 is IN only.

AMP board unit

Power cable connector (×3)

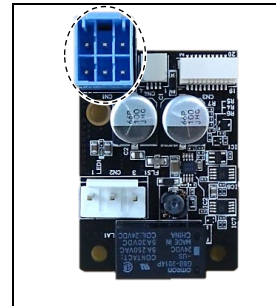
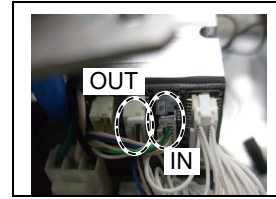

- (16) Disconnect the Hand I/O cable and air tube from the user plate.

NOTE  Mounting screws for the Hand I/O cable are very small.

Be sure to keep the screws.

Press the ring on the fittings to pull out the air tube. (ø6×2, ø4×1)

Remember the cable layout for reconnecting the cables correctly after replacement.

- (17) Remove the ground wire that secured on the user plate.

- (18) Cut off the wire tie binding the cables in the arm side.

- (19) Remove the nut that secures the cable duct fittings to the user plate and pull out the cables from the user plate.

(19) User Plate side nut (20) Motor Box side nut

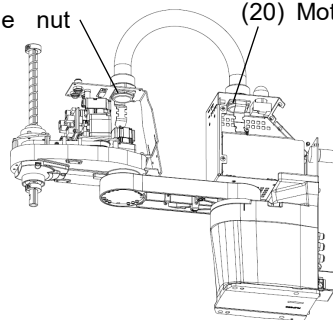

- (20) Remove the nut that secures the cable duct fittings to the motor box.

Cable Unit Installation

- (1) Pass the new cables through the base, cable fixing plate, and nut, and turn the fittings to secure the cables.

Apply adhesive to the screw of duct fittings.

Tighten the nut to fix.



- (2) Pass the cables in the user plate side through the user plate and nut and turn the fittings to secure the cables.

Apply adhesive to the screw of duct fittings.

Tighten the nut to fix.

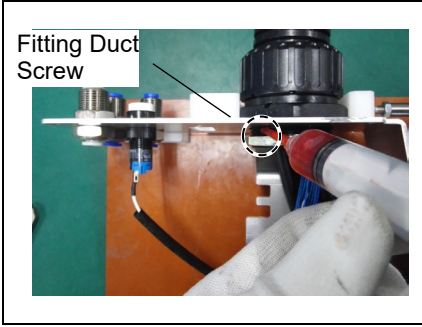

- (3) Connect the following parts to the inside of the user plate.

- Air tube
- Hand I/O cable

- (4) Connect the connector of the Joint # 2, 3, 4 motor unit and the connector of the AMP board.

- Motor Unit
- Signal cable connector (IN/OUT ×1 for each)

NOTE  Signal cable for joint #4 is IN only.

- AMP board unit
- Power cable connector (×3)

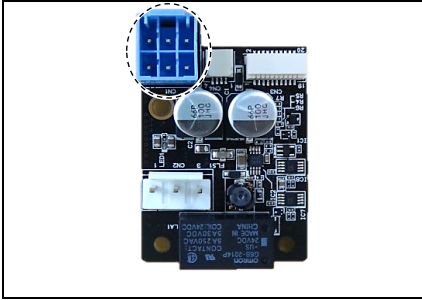
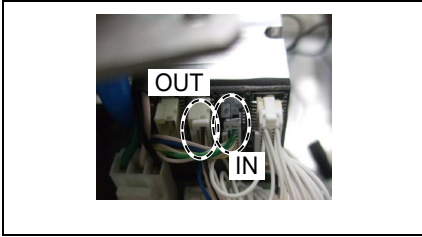

- (5) Mount the user plate.
Reference: 7.7 User Plate
- (6) Connect the ground wire on the arm side to the user plate.
- (7) Bind the cables with a wire tie as removed in the removal step (18).
- (8) Connect the ground wire on the base side to the cable fixing plate on the base side.

(9) Connect CPU/DPB board connector.

- A: Power connector (IN/OUT ×1 for each)
- B: Power cable connector (×1)
- C: Signal cable connector
- D: Hand I/O connector
- E: LED connector
- F: Regenerative resistor 1 (T6-B only)
- G: Regenerative resistor 2 (T6-B only)
- H: Battery connector

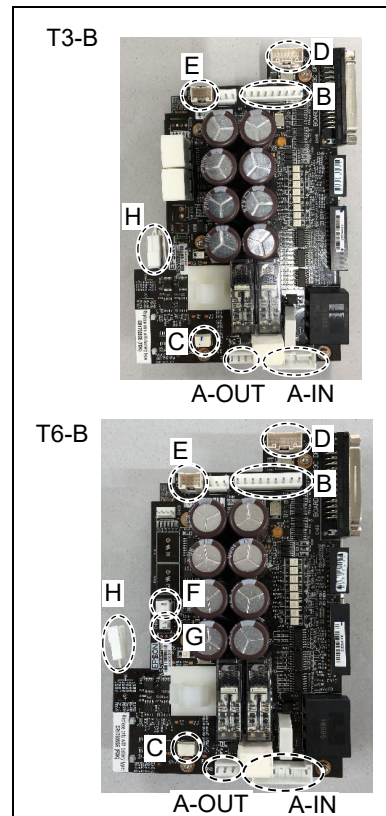

(10) Mount CPU/DPB board to base.

- Hexagon socket head cap button bolt: 5-M3×5
- Tightening torque: 0.45± 0.1 N·m

Attach the radiation sheet on the back side of the CPU/DPB boards when mounting.

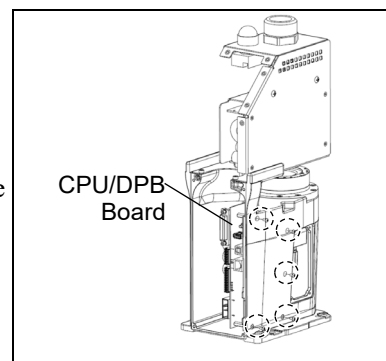

(11) Connect the following parts to the inside of the connector plate.

- Air tube
- TP connector

(12) Connect the AMP board connector.

- A: Power cable connector
- B: Signal cable connector
- C: Motor connector

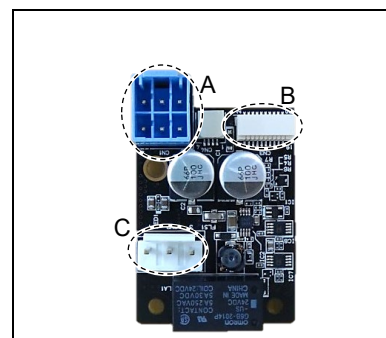

- (13) T3-B : Mount base side cover.

Reference: 7.6 *Base Side Cover*

- T6-B : Mount the joint #1 AMP board plate and the regenerative resistor plate.

Connect the connector of regenerative resistor junction cable.

Mounting bolts: 4-M4×8 Sems

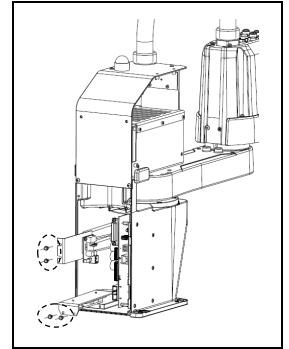

- (14) Bind the cables with a wire tie as removed in the removal step (6).

- (15) Place and secure the arm top cover without the cables being stuck.

Reference: 7.1 *Arm Top Cover*

- (16) Mount the power unit cover.

Reference: 7.5 *Power Unit Cover*

- (17) Mount the connector plate.

Reference: 7.4 *Connector Plate*

8.2 Insert or Pull out of Power Cable

	Name	Quantity	NOTE
Tools	Cross-point screwdriver (No. 2)	1	For cross-recessed screw

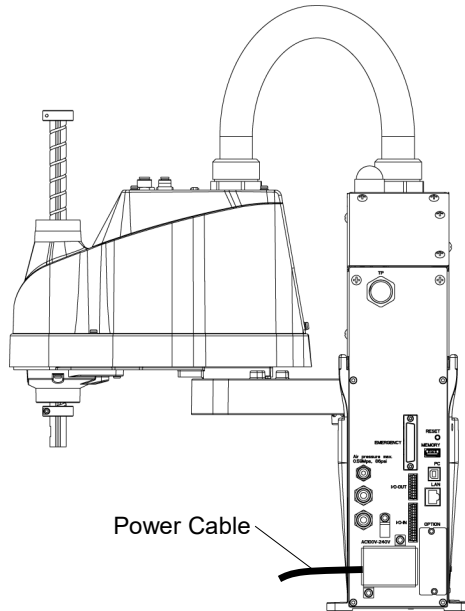

Power Cable Removal

- (1) Turn OFF the Manipulator.
- (2) Remove the power cable cover.

Reference: 7.3 *Power Cable Cover*

- (3) Remove power cable clamp.
Remove power cable connector.



NOTE When removing the power cable connector, pull it out with pushing clips on both side of the connector.

Power Cable Installation

- (1) Connect power cable connector and install power cable clamp.
- (2) Mount the power cable cover.

Reference: 7.3 *Power Cable Cover*

9. Joint #1



- Do not connect or disconnect the motor connectors while the power to the robot system is turned ON. Connecting or disconnecting the motor connectors with the power ON is extremely hazardous and may result in serious bodily injury as the Manipulator may move abnormally, and also may result in electric shock and/or malfunction of the robot system.
- To shut off power to the robot system, disconnect the power plug from the power source. Be sure to connect the AC power cable to a power receptacle. DO NOT connect it directly to a factory power source.
- Before performing any replacement procedure, turn OFF the robot system and related equipment, and then disconnect the power plug from the power source. Performing any replacement procedure with the power ON is extremely hazardous and may result in electric shock and/or malfunction of the robot system.



- Be careful not to apply excessive shock to the motor shaft when replacing the motors. The shock may shorten the life cycle of the motors and encoder and/or damage them.
- Never disassemble the motor and encoder. A disassembled motor and encoder will cause a positional gap and cannot be used again.

After parts have been replaced (motors, reduction gear units, a brake, timing belts, ball screw spline unit, etc.), the Manipulator cannot operate properly because a mismatch exists between the origin stored in each motor and its corresponding origin stored in the Robot system.

Because of that, it is necessary to perform calibration (encoder rest and calibration) to match these origins.

Refer to “17. Calibration” to execute the calibration.

T3-B

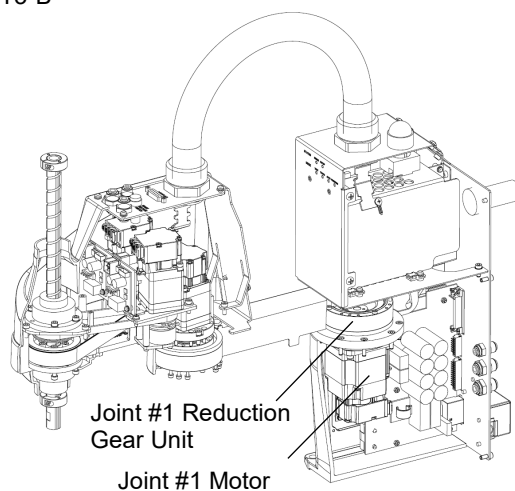

T6-B

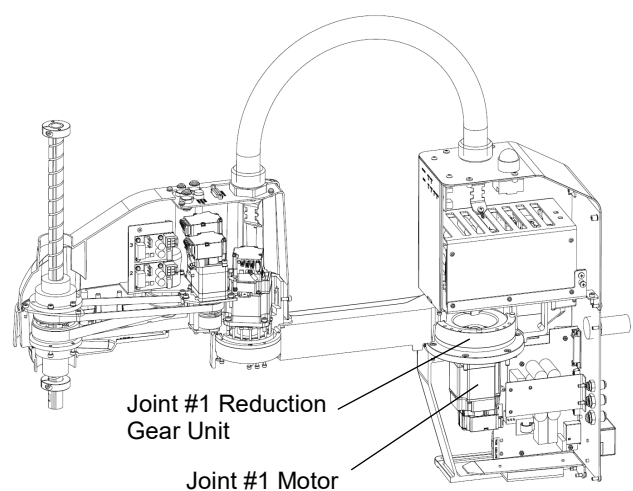

9.1 Replacing Joint #1 Motor

	Name		Quantity	Note
Maintenance parts	Motor	200W	1	T3-B: 2207934
		300W	1	T6-B: 2207937
	O-ring	Between reduction gear units and Arm #1	1	T3-B: 1213266 T6-B: 1510528
		Between reduction gear units and flange	1	T3-B: 1868478 T6-B: 1868480
		Between motor and flange	1	T3-B: 1709549 T6-B: 1520371
	Elliptic cam positioning jig		1	T3-B: 1875189 T6-B: 1875190
Tools	Hexagonal wrench	Width across flats: 2 mm	1	For M4 set screw For M3 button bolt
		Width across flats: 2.5 mm	1	For M3 screw For M4 button bolt
		Width across flats: 3 mm	1	For M4 screw
		Width across flats: 3 mm	1	For M5 screw
	Torque wrench		1	
	Cross-point screwdriver (No. 2)		1	For cross-recessed screw
	Wiping cloth		1	For wiping grease
Grease	Grease	SFB No.1	-	

Joint #1 motor Removal (1) Turn OFF the Manipulator.

(2) Remove the power unit cover.

Reference: 7.5 Power Unit Cover

(3) Remove the connector plate.

Reference: 7.4 Connector Plate

(4) Remove the following parts that connected to the connector plate (inside).

Air tube

TP connector

(5) T3-B: Remove the base side cover.

Reference: 7.6 Base Side Cover

T6-B: Remove the AMP board plate of joint #1.

2-M4×8 Sems

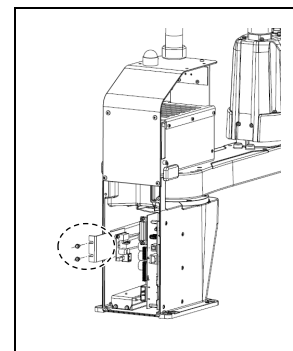

(6) Remove the connector of AMP board.

- A: Power cable connector
- B: Signal cable connector
- C: Motor connector

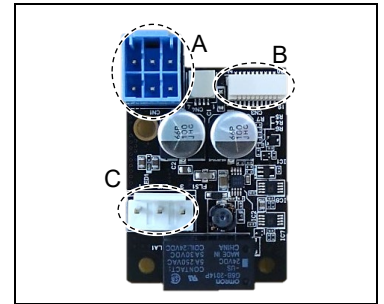

(7) Remove the AMP board.

3-M3×6 Sems

NOTE Radiation sheet is attached on the back side of the AMP board. Be careful not to lose or break it.

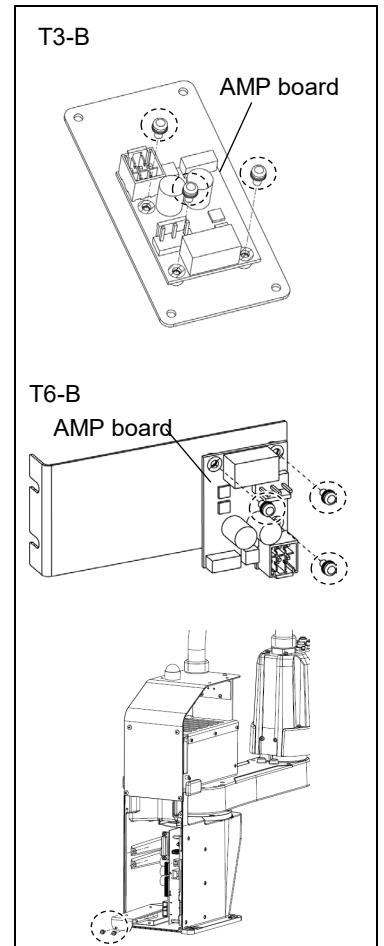

T6-B: Disconnect the connector of regenerative resistor junction cable. Then, remove the regenerative resistor fixing plate.

2-M4×8 Sems

(8) Unscrew CPU/DPB board mounting screws.

Hexagon socket head cap button bolt: 5-M3×5

Remove CPU/DPB board from a base.

NOTE Radiation sheet is attached on the back of CPU/DPB board. Be careful not to lose or break it.

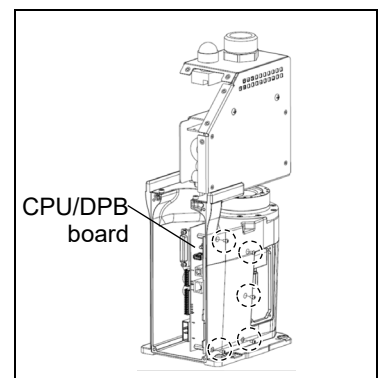

- (9) Remove the CPU/DPB board connector.
- A: Power connector (IN/OUT ×1 for each)
 - B: Power cable connector (×1)
 - C: Signal cable connector
 - D: Hand I/O connector
 - E: LED connector
 - F: Regenerative resistor 1 (T6-B only)
 - G: Regenerative resistor 2 (T6-B only)
 - H: Battery connector

NOTE  Remember the cable layout for reconnecting the cables correctly after replacement.

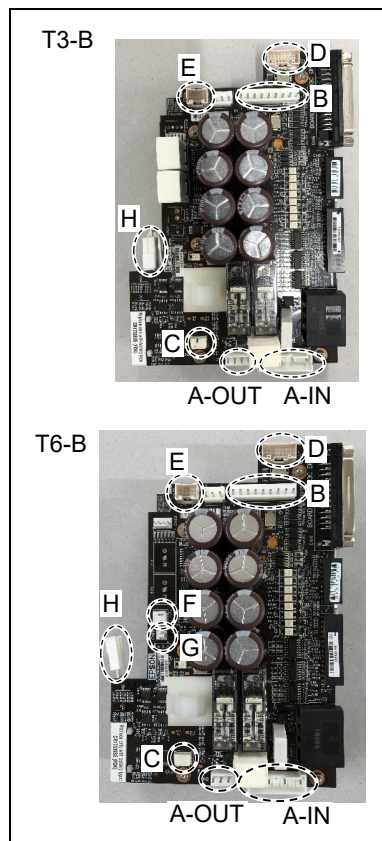

- (10) Remove the connector of the Joint #1 motor unit.
- Signal cable connector (IN/OUT ×1 for each)

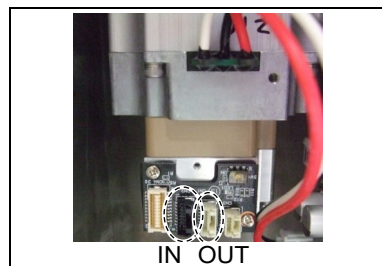

- (11) T3-B: Remove the power board cover.

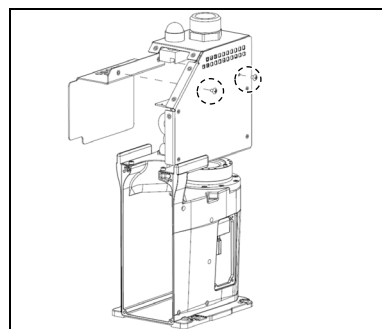

T6-B: Remove the LED board connector.

A: LED - LED board connector

Cut off the wire tie binding the internal cables.
Then, remove the top board.

Hexagon socket head cap button bolt: 4-M4×10

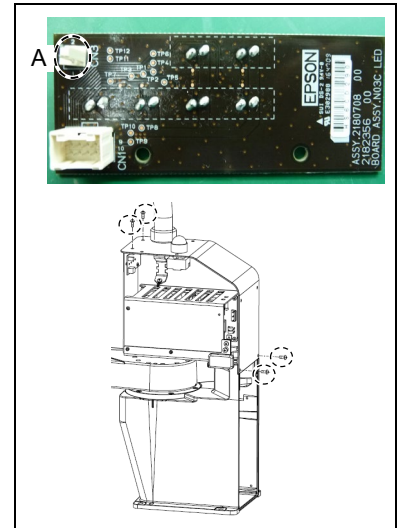

(12) Unscrew the Power unit mounting screws.

T3-B: 3-M4×10

T6-B: 4-M4×10

Remove power unit from the base.

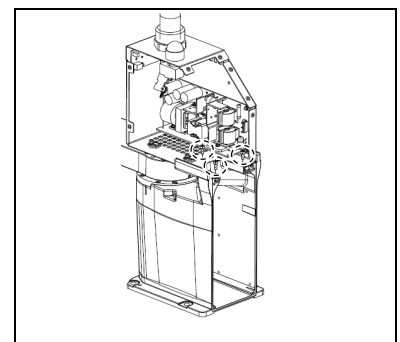

(13) Remove the Arm #1 mounting bolt in the Joint #1 side and remove the arm.

T3-B: A: 8-M3×30
B: 4-M3×15

T6-B: A: 8-M4×40
B: 4-M3×20

NOTE  There is an O-ring between the reduction gear units and Arm #1.
Be sure not to lose the O-ring.

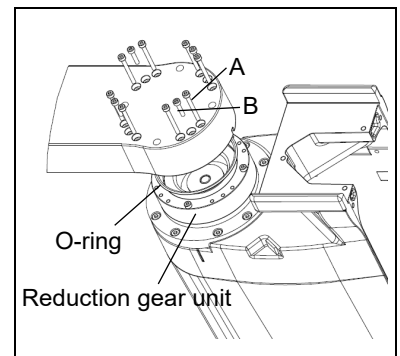

(14) Remove the screws mounting the Joint #1 flange on the base.

T3-B: 8-M4×15

T6-B: 6-M5×15

Remove the Joint #1 motor unit from the base.

NOTE  When removing the Joint #1 motor unit, pull it up slowly to avoid hitting the base.

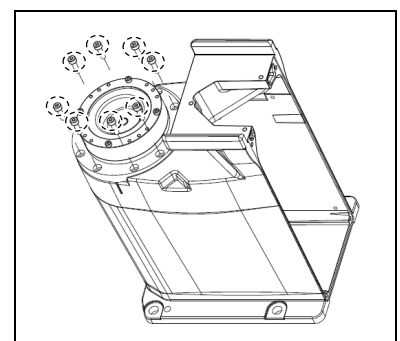

(15) T3-B : Loosen the motor mounting screws on the Joint #1 flange and remove the motor unit.
4-M4×15+small washer

NOTE  There is an O-ring between the Joint #1 flange and the motor.
Be sure not to lose the O-ring.

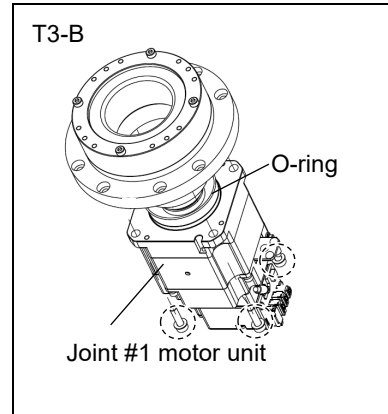

T6-B : Remove the motor mounting screws and the washer on the Joint #1 flange.
4-M4×12+small washer

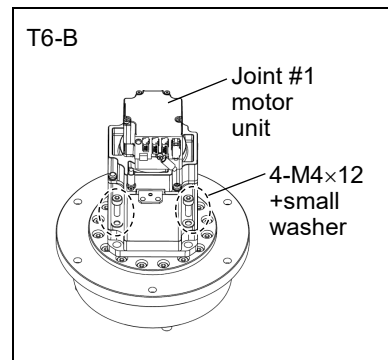

Unscrew the reduction gear units mounting screws on the Joint #1 flange.

NOTE  Rotate the motor around the shaft so that the reduction gear units mounting screws are visible, then operate.
16-M4×22

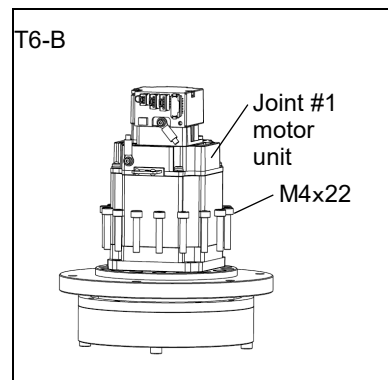

Mount the motor mounting screws.
4-M4×12+small washer

Remove the reduction gear units from the flange which the motor is mounted.

NOTE  There is an O-ring between the Joint #1 flange and the reduction gear units.
Be sure not to lose the O-ring.

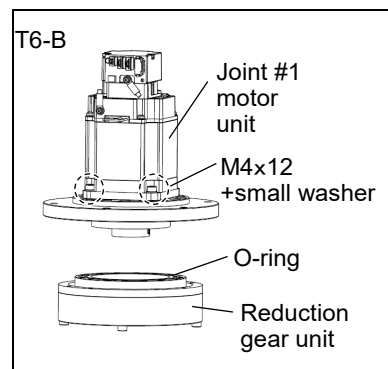

(16) Remove the elliptic cam bearing from the Joint #1 motor.

There is a brass bushing in one of the set screw holes. Be sure not to lose the bushing.

T3-B: A: Brass bushing M4
 B: Set screw 2-M4×6

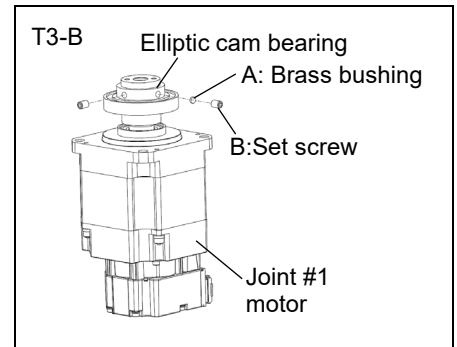

T6-B: A: Brass bushing M5
 B: Set screw 2-M5×6

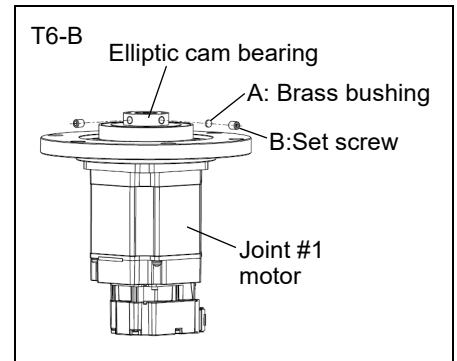

(17) T6-B : Unscrew the motor mounting screws. Then, remove the Joint #1 flange and O-ring.

4-M4×12+small washer

NOTE  There is an O-ring between the Joint #1 flange and the motor. Be sure not to lose the O-ring.

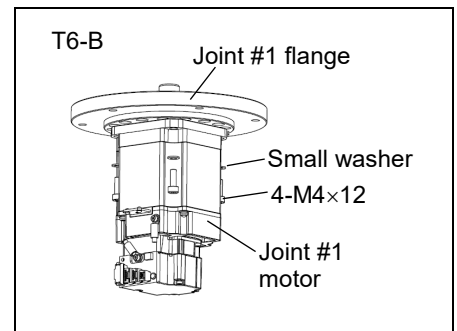

Joint #1 motor Installation

NOTE For tightening hexagon socket head cap bolts, refer to “2.4 Tightening Hexagon Socket Head Cap Bolts”.

- (1) T6-B : Set the O-ring (between the motor and the flange) on the motor mounting surface, and mount the joint #1 flange.
4-M4×12+small washer
Tightening torque: 2 ± 0.2 N·m

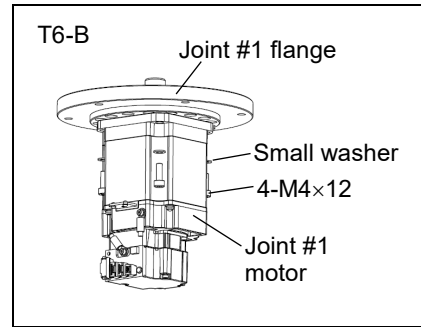

- (2) T6-B : Apply grease between the motor and the elliptic cam bearing.
Grease volume: SFB-No.1: 16g

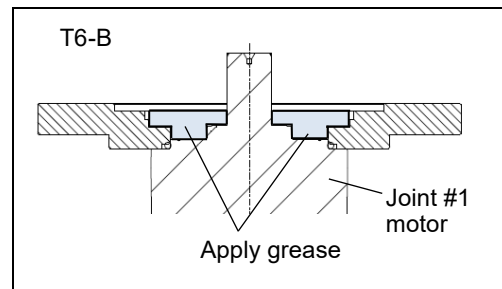

NOTE Be careful of the flange notch and motor position when mounting the flange.



To insert the motor, turn it slowly from side to side by hand and push in.
Replace O-ring to new one if there is swelling, scratch, or wear.

- (3) Mount the elliptic cam bearing on the motor.

Mount the bearing so that the end faces of the elliptic cam bearing and the motor shaft have the following dimensions.

T3-B: 4 mm

T6-B: 0 mm

Be careful of the direction of the elliptic cam bearing.

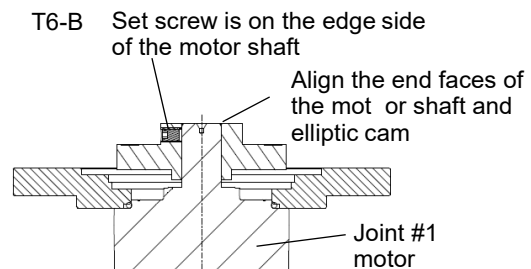
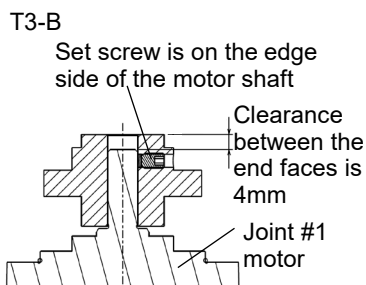

When using the elliptic cam positioning jig, mount the jig and temporarily secure it. Secure so that the screw head lightly touches the jig.

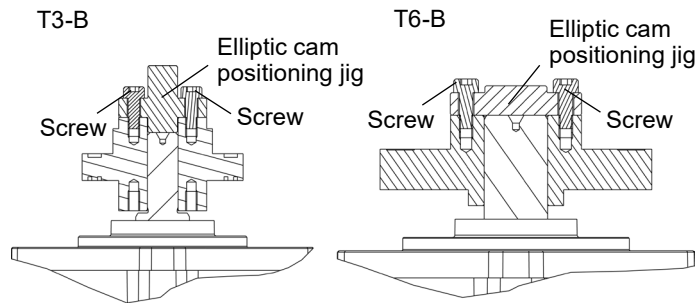

NOTE



The jigs for T3-B and T6-B have different dimensions. Be careful of the dimensions.

- (4) Secure the elliptic cam bearing by the set screw.

T3-B:

- A: Brass bushing : M4
- B: Set screw : 2-M4×6
- Tightening torque: : 2.5 ± 0.15 N·m

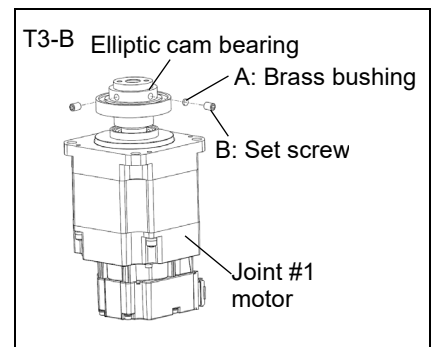

T6-B:

- A: Brass bushing : M5
- B: Set screw : 2-M5×6
- Tightening torque: : 4 ± 0.2 N·m

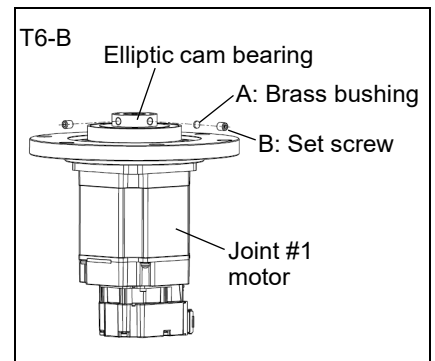

NOTE



Tighten one of the set screws on the flat face of the motor shaft until the screw just touches the surface. Insert a bushing into the other set screw hole to prevent damage to the motor shaft. Then, tighten both set screws.

When using the elliptic cam positioning jig, unscrew the temporarily securing screws and remove the elliptic cam positioning jig.

 CAUTION	<ul style="list-style-type: none"> ■ Refer to the figure above for the orientation of the elliptic cam bearing. Be sure to mount the elliptic cam bearing properly. Improper mounting of the elliptic cam bearing will result in improper function of the Manipulator.
--------------------	---

(5) T3-B : Apply grease between the motor and the elliptic cam bearing.

Grease volume: SFB-No.1: 4g

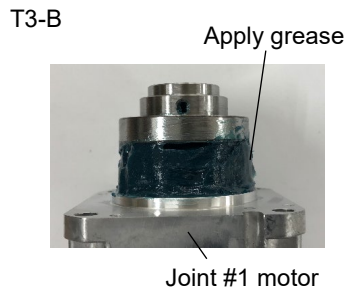
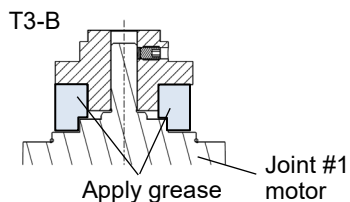

(6) T6-B :

Mount the O-ring (between the reduction gear units and the flange) to the grooves on the internal gear.

NOTE  Make sure that the O-ring does not come out of the grooves.

Replace O-ring to new one if there is swelling, scratch, or wear.

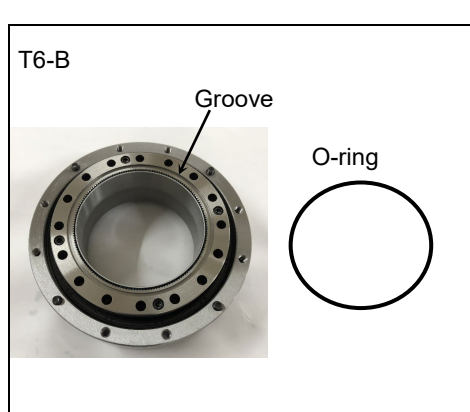

Place the reduction gear units on the table, and mount the motor unit with the Joint #1 flange to the reduction gear units from upper side.

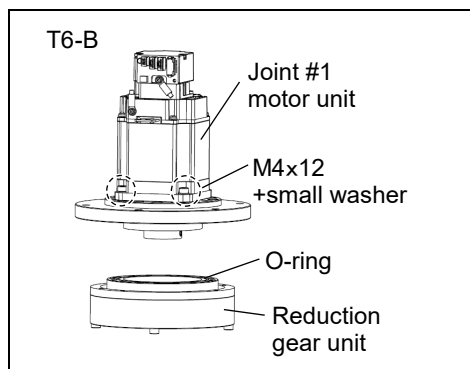

Unscrew the motor mounting screws.

4-M4x12+small washer

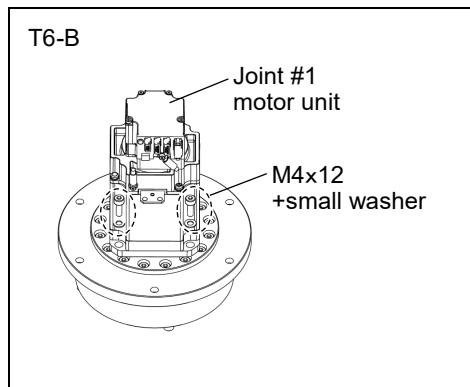

Mount the reduction gear units mounting screws.

Rotate the motor around the shaft so that the reduction gear units mounting screws are visible, then operate.

T6-B: 16-M4×22

Loosely fasten all bolts in a crisscross pattern so that the bolts will be fastened evenly.

Then, using a torque wrench, tighten each bolt securely in a crisscross pattern at the torque specified in the table below.

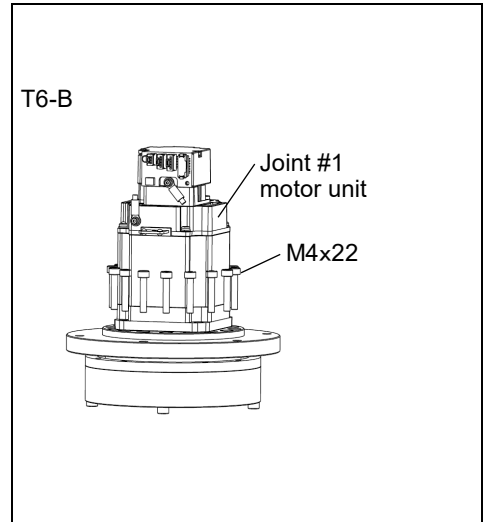

Name	Model	Bolt type	Bolts	Tightening torque
Joint #1 reduction gear units	T6-B	M4×25	16	5.5 ± 0.25 N·m

NOTE Be careful not to apply too much force since it may damage the parts.

- (7) T3-B : Set the O-ring (between the motor and the flange) on the motor mounting surface, and temporarily secure the motor unit on the Joint #1 flange.
4-M4×15+small washer

NOTE Be careful of the direction of the motor. Align the orientation of the motor board with the alignment dent in the flange.

NOTE Secure temporarily the screws.
After this, an alignment of the reduction gear units are performed.
(Secure so that the screw head lightly touches the flange base.)

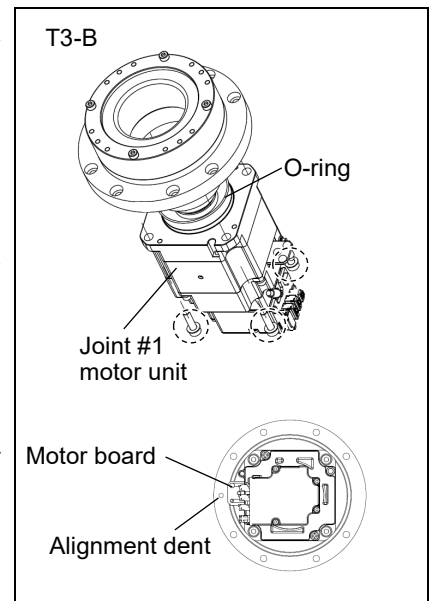

T6-B: Mount the motor mounting screws.

4-M4×12+small washer

NOTE Be careful of the direction of the motor. Align the orientation of the motor board with the alignment dent in the flange.

NOTE Secure temporarily the screws.
After this, an alignment of the reduction gear units are performed.
(Secure so that the screw head lightly touches the flange base.)

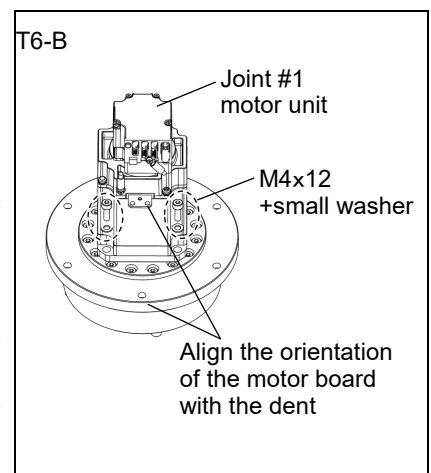

- (8) Perform an alignment of the reduction gear units.
Mount the supplied screws for alignment (×2) on the reduction gear units.

2-M3×30

Grab the alignment screws by hand and rotate the elliptic cam bearing three times clockwise. Then, rotate three times counterclockwise.

- (9) Tighten the motor mounting screws which secured temporarily to secure the motor.

Loosely fasten all bolts in a crisscross pattern so that the bolts will be fastened evenly.

T3-B: 4-M4×15+small washer

T6-B: 4-M4×15

Then, using a torque wrench, tighten each bolt securely in a crisscross pattern at the torque specified below.

Tightening torque:
M4: $5.5 \pm 0.25 \text{ N}\cdot\text{m}$

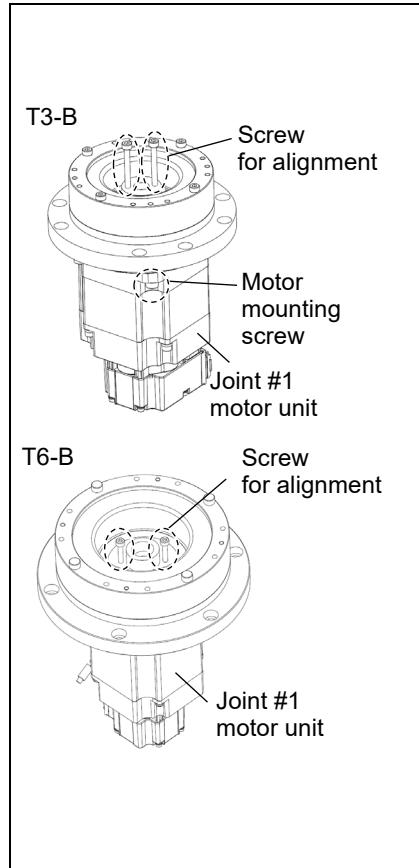

- (10) After mounting the motor, unscrew the supplied screws for alignment (×2) from the reduction gear units.

2-M3×30

- (11) Apply grease to the inside of the flex gear.

Apply grease to the same height as the end face of the elliptic cam bearing.

Grease volume T3-B: SFB No.1: 13 g

T6-B: SFB No.1: 16g

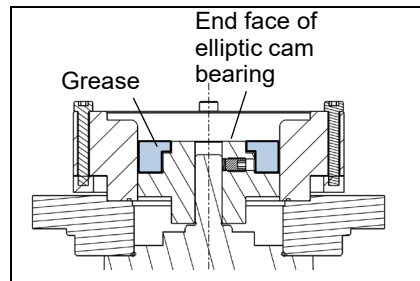

- (12) Mount the Joint #1 unit to the base.

Secure the Joint #1 motor cables facing toward the back of the base.

- (13) Set the O-ring (between reduction gear units and Arm #1) removed in the removal step (10) into the O-ring groove of the arm.

Replace O-ring to new one if there is swelling, scratch, or wear.

(14) Mount the arm to the Joint #1 unit.

Loosely fasten all bolts in a crisscross pattern so that the bolts will be fastened evenly.

T3-B: A: 8-M3×30
B: 4-M3×15

T6-B: A: 8-M4×40
B: 4-M3×20

Then, using a torque wrench, tighten each bolt securely in a crisscross pattern at the torque specified below.

Tightening torque:

M3: 2.5 ± 0.15 N·m

M4: 5.5 ± 0.25 N·m

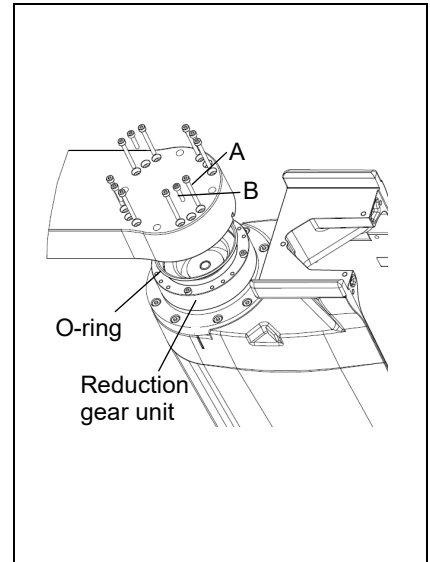

(15) Mount the power unit to the base.

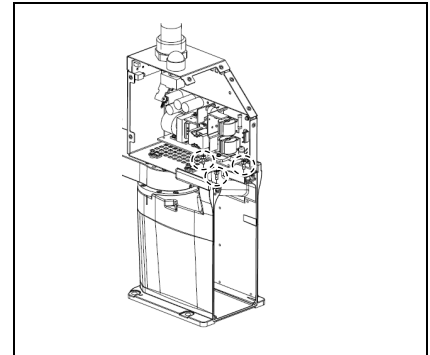

(16) T3-B: Mount a cover of power board.

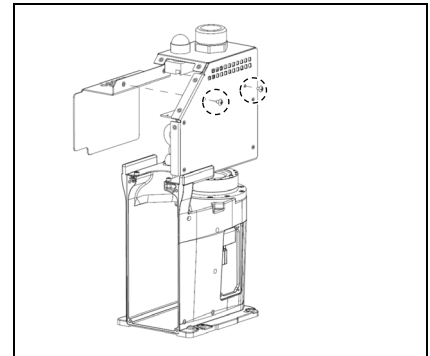

T6-B: Mount the top board of the power unit.

Hexagon socket head cap button bolt: 4-M4×10

Tightening torque: 2.0 ± 0.1 N·m

Bind the internal cables with a wire tie as removed in the removal procedure (11).

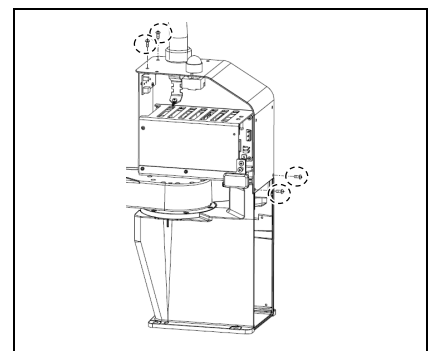

(17) Connect the LED board connector.

A: LED - LED board connector

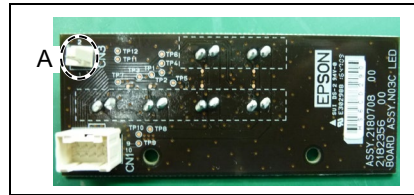

(18) Connect the connector of Joint #1 motor unit.

Signal cable connector (IN/OUT ×1 for each)

(19) Connect CPU/DPB board connector.

A: Power connector (IN/OUT ×1 for each)

B: Power cable connector (×1)

C: Signal cable connector

D: Hand I/O connector

E: LED connector

F: Regenerative resistor 1 (T6-B only)

G: Regenerative resistor 2 (T6-B only)

H: Battery connector

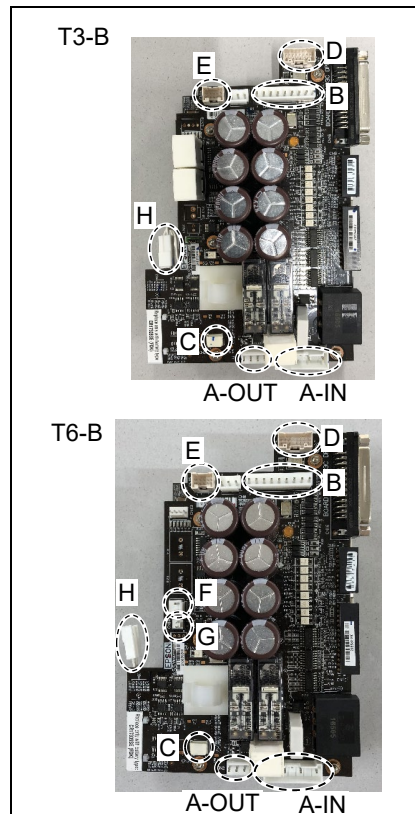

(20) Mount CPU/DPB board to base.

Hexagon socket head cap button bolt: 5-M3×5

Tightening torque: 0.45 ± 0.1 N·m

NOTE
 Attach the radiation sheet on the back side of the CPU/DPB boards when mounting.

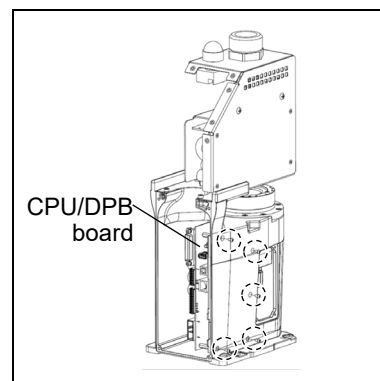

(21) Mount the AMP board.

NOTE
 Attach the radiation sheet on the back side of the AMP board.

(22) Connect the AMP board connector.

A: Power cable connector

B: Signal cable connector

C: Motor connector

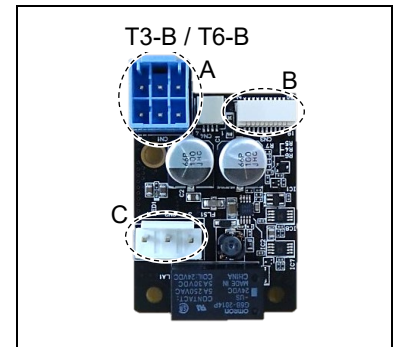

(23) T3-B: Mount the base side cover.

Reference: 7.6 *Base Side Cover*

T6-B: Mount the Joint #1 AMP board plate.

(24) Connect the following parts to the inside of the connector plate.

Air tube

TP connector

(25) Mount the Power unit cover.

Reference: 7.5 *Power Unit Cover*

(26) Mount the connector plate.

Reference: 7.4 *Connector Plate*

(27) Turn ON the Manipulator.

Reference: *T-B series Manual T3-B T6-B Manipulator 6.5 LED*

NOTE



DO NOT turn OFF the power until the Manipulator starts.

When you connect a motor unit connected to another axis, an error 5009 or 9709 will occur. To clear the error, enter the following command in [Command Window] and execute it.

Joint #1: > MUIIDReset 1

Joint #2: > MUIIDReset 2

Joint #3: > MUIIDReset 3

Joint #4: > MUIIDReset 4

Reboot the Controller.

(28) Perform the calibration for the Joint #1.

Reference: 17. *Calibration*

9.2 Replacing Joint #1 Reduction Gear Units

A reduction gear unit consists of the following three parts. When replacing the reduction gear units, be sure to always replace the elliptic cam bearing, flex gear, and internal gear all together as one set.

For details of the parts, refer to “19. Maintenance Parts List”.

	Name		Quantity	Note
Maintenance part	Reduction Gear Units		1	T3-B: 1829508
			1	T6-B: 1829509
Tools	Hexagonal wrench	Width across flats: 2 mm	1	For M4 set screw
		Width across flats: 2.5 mm	1	For M3 screw
		Width across flats: 3 mm	1	For M4 screw
	Torque wrench		1	
	Nippers		1	
	Spatula		1	For applying grease
	Wiping cloth		1	For wiping grease (Flange)
			1	For wiping grease (Bolt)
Grease	Grease	SFB No.1	-	

Joint #1 Reduction Gear Unit Removal

- (1) Remove the Joint #1 motor unit.

Reference: 9.1 Replacing Joint #1 Motor “Removal procedure”

For T6-B, remove the Joint #1 motor and the reduction gear units from the flange.

- (2) T3-B:

Remove the reduction gear units from the Joint #1 flange.

T3-B: 10-M3×20

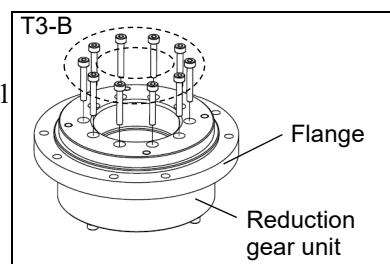

Joint #1
Reduction
Gear Unit
Installation

- (1) A new reduction gear unit contains the parts shown in the picture on the right when it is unpacked.

The internal gear, tooth grooves of the flex gear, and the elliptic cam bearing are pre-greased.

Wipe grease if it is attached to the mounting surface of the internal gear.

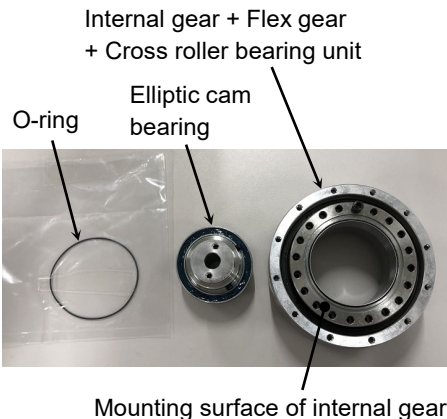

- (2) T3-B : Unscrew the temporarily securing screws (M3x4) of the internal gear.

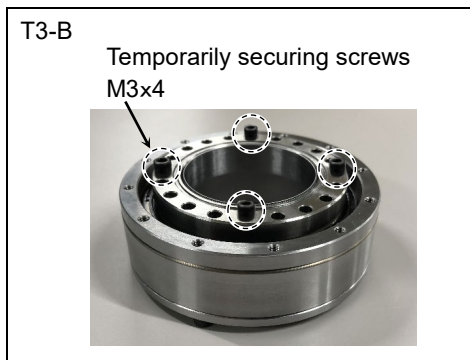

NOTE  T6-B : Do not unscrew the securing screws (M3x4) of the internal gear.

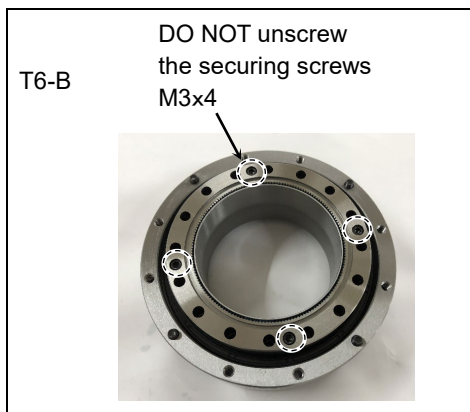

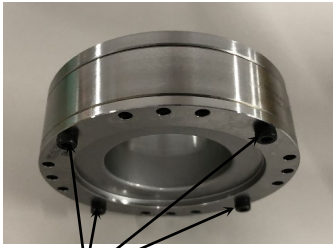
 CAUTION	<p>■ Never adjust (loosen or tighten) the mounting bolts between the flex gear and cross roller bearing unit.</p> <p>If the bolts are adjusted, it requires centering of the parts by the reduction gear unit manufacturer.</p> <div style="text-align: center;">  <p>DO NOT loosen these four bolts</p> </div>
---	--

- (3) Mount the O-ring (between the reduction gear units and the flange) to the grooves on the internal gear.

Make sure that the O-ring does not come out of the grooves.

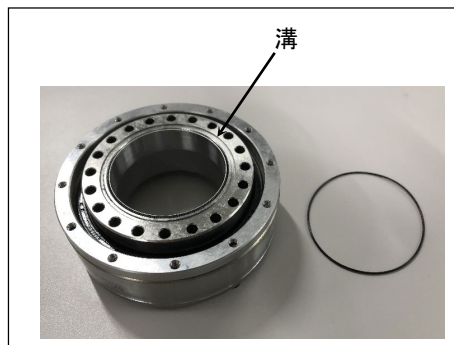

- (4) T3-B: Secure the flange on the reduction gear units.

T3-B: 10-M3×20

Loosely fasten all bolts in a crisscross pattern so that the bolts will be fastened evenly.

Then, using a torque wrench, tighten each bolt securely in a crisscross pattern at the torque specified in the table below.

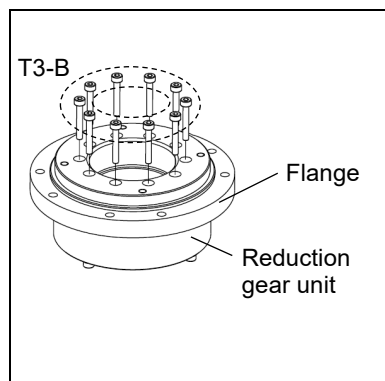

Name	Model	Bolt type	Bolts	Tightening torque
Joint #1 reduction gear units	T3-B	M3×20	10	2.5 ± 0.15 N·m
	T6-B	M4×25	16	5.5 ± 0.25 N·m

NOTE



Be careful not to apply too much force since it may damage the parts.

- (5) T3-B: Mount the Joint #1 motor.

Reference: 9.1 Replacing Joint #1 Motor “Installation procedure”

T6-B: Mount the Joint #1 reduction gear units and the motor.

Reference: 9.1 Replacing Joint #1 Motor “Installation procedure”

10. Joint #2



- Do not connect or disconnect the motor connectors while the power to the robot system is turned ON. Connecting or disconnecting the motor connectors with the power ON is extremely hazardous and may result in serious bodily injury as the Manipulator may move abnormally, and also may result in electric shock and/or malfunction of the robot system.
- To shut off power to the robot system, disconnect the power plug from the power source. Be sure to connect the AC power cable to a power receptacle. DO NOT connect it directly to a factory power source.
- Before performing any replacement procedure, turn OFF the robot system and related equipment, and then disconnect the power plug from the power source. Performing any replacement procedure with the power ON is extremely hazardous and may result in electric shock and/or malfunction of the robot system.



- Be careful not to apply excessive shock to the motor shaft when replacing the motors. The shock may shorten the life cycle of the motors and encoder and/or damage them.
- Never disassemble the motor and encoder. A disassembled motor and encoder will cause a positional gap and cannot be used again.

After parts have been replaced (motors, reduction gear units, a brake, timing belts, ball screw spline unit, etc.), the Manipulator cannot operate properly because a mismatch exists between the origin stored in each motor and its corresponding origin stored in the Robot system.

Because of that, it is necessary to perform calibration (encoder rest and calibration) to match these origins.

Refer to “17. Calibration” to execute the calibration.

T3-B

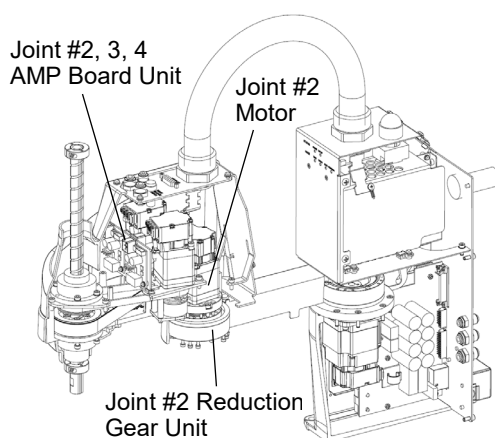

T6-B

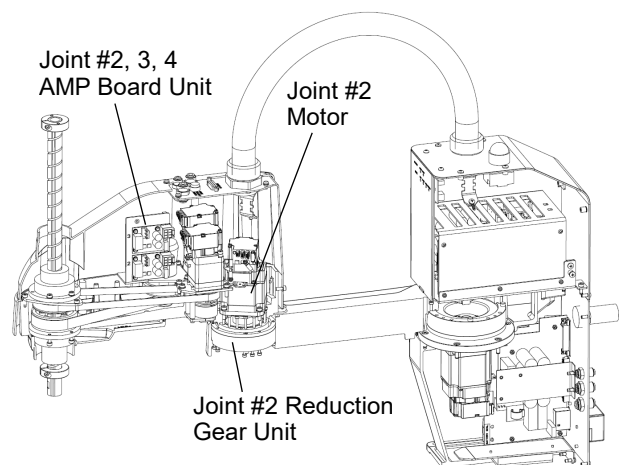

10.1 Replacing Joint #2 Motor

	Name		Quantity	Note
Maintenance part	Motor	100W	1	T3-B: 2207935
		200W	1	T6-B: 2207938
	O-ring	Between reduction gear units and Arm #2	1	T3-B: 1868478 T6-B: 1868479
	Elliptic cam positioning jig		1	T3-B: 1875189 T6-B: 1875190
Tools	Hexagonal wrench	Width across flats: 2 mm	1	For M4 set screw
		Width across flats: 3 mm	1	For M4 screw
	Cross-point screwdriver	No.2	1	For cross-recessed screw
	Torque wrench		1	
	Wiping cloth		1	For wiping grease
Grease	Grease	SFB No.1	-	

NOTE  A brake is mounted on the Joint #3 motor to prevent the shaft from lowering down due to the weight of the end effector while the power to the Manipulator is OFF or while the motor is in OFF status (MOTOR OFF).

Refer to removal steps to move the shaft down to its lower limit before the replacement procedure.

Joint #2 Motor Removal

- (1) Turn ON the Manipulator.
- (2) Press and hold the brake release switch to let the shaft down. Be sure to keep enough space and prevent the end effector hitting any peripheral equipment.

The brake release switch affects only Joint #3. When the brake release switch is pressed, the Joint #3 brake is released.

Be careful of the shaft falling while the brake release switch is being pressed because the shaft may be lowered by the weight of the end effector.

- (3) Turn OFF the Manipulator.
- (4) Remove the Arm Top Cover.
Reference: 7.1 *Arm Top Cover*
- (5) Remove the User Plate.
Reference: 7.7 *User Plate*
- (6) Loosen the mounting screws of the Joint #2, 3, 4 AMP board unit, and remove the board unit from Arm #2.
2-M3×10 Sems

NOTE  Do not remove the mounting screws and the connector.

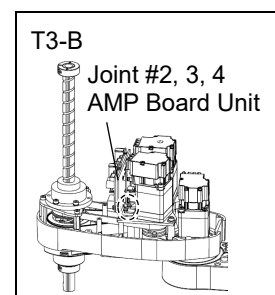

Remove the connector of the Joint #2 AMP board.

D: Motor cable connector

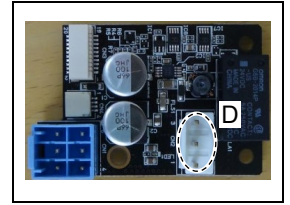

- (7) Unscrew the screws that mounts the Arm #2 and the reduction gear unit on the Arm #1, and remove the Arm #2 and the reduction gear unit from the Arm #1.

T3-B: A: 8-M3×30+M3 small washer

B: 4-M3×15+M3 small washer

T6-B: A: 8-M3×32+8-M3 small washer

B: 4-M3×12+4-M3 small washer



There is an O-ring between the reduction gear units and Arm #1.

Be sure not to lose the O-ring.

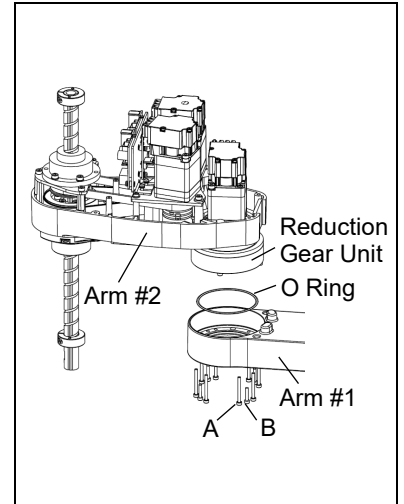

- (8) Unscrew the motor unit mounting screws.

T3-B: Motor flange mounting screws

3-M4×12+washer

T6-B: Motor mounting screws

4-M4×12+washer

Remove the Joint #2 motor unit from Arm #2.

To pull out the motor smoothly, move the Arm #2 slowly by hand while pulling the motor.



T3-B: Remove the motor flange and the motor. Do not separate the motor flange and the motor.



T6-B: There is no motor flange.

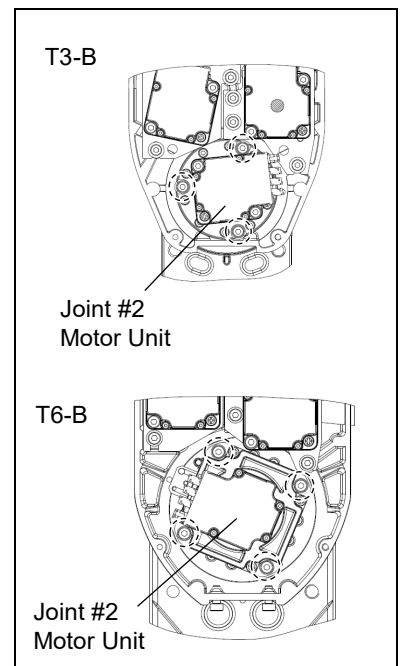

- (9) Remove the grease receiver from the elliptic cam bearing on the Joint #2 motor.

2-M3×6+washer+collar



Collars are in the grease receiver.

Be sure not to lose the collars.

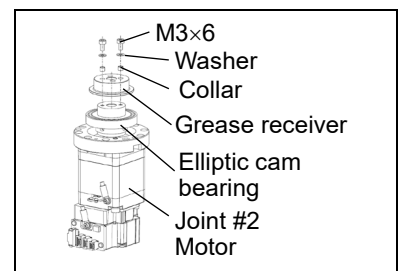



(10) Remove the elliptic cam bearing from the Joint #2 motor.

2-M4×6 set screw

M4 brass bushing

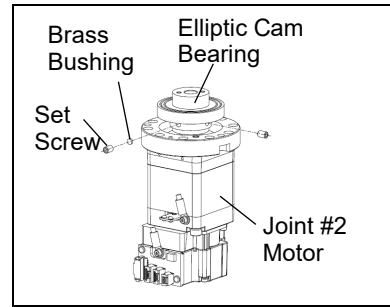
NOTE  There is a brass bushing in one of the set screw holes. Be sure not to lose the bushing.



Joint #2 Motor Installation **NOTE**  For tightening hexagon socket head cap bolts, refer to “2.4 Tightening Hexagon Socket Head Cap Bolts”.

(1) Mount the elliptic cam bearing on the Joint #2 motor.

Mount the bearing so that the end faces of the elliptic cam bearing and the motor shaft have the following dimensions.

T3-B: 8.5 mm

T6-B: 1.5 mm

NOTE  Be careful of the direction of the elliptic cam bearing.

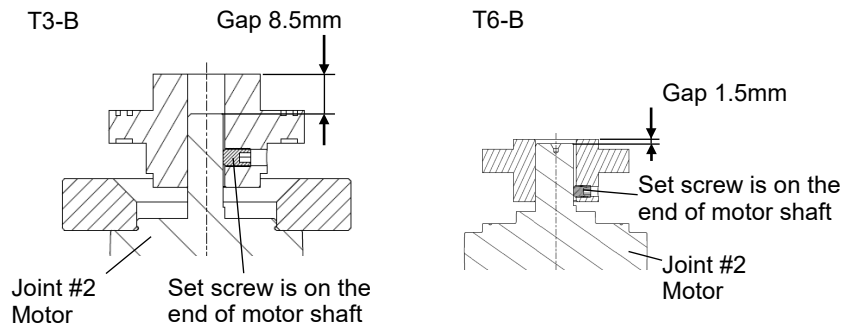

When using the elliptic cam positioning jig, mount the jig and temporarily secure it. Secure so that the screw head lightly touches the jig.

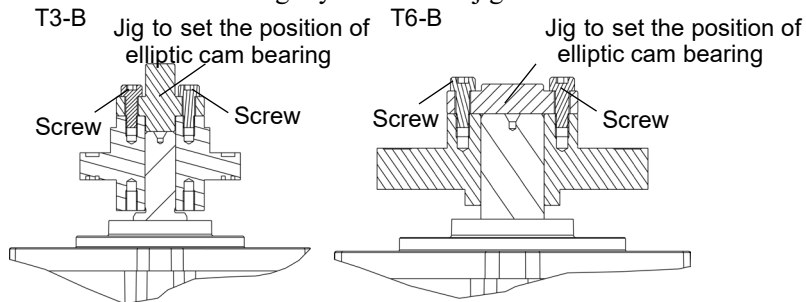

NOTE  The jigs for T3-B and T6-B have different dimensions. Be careful of the dimensions.

- (2) Secure the elliptic cam bearing by the set screw.
 - 2-M4×6 set screw
 - M4 brass bushing
 - Tightening torque: $2.5 \pm 0.15 \text{ N}\cdot\text{m}$

NOTE
 Tighten one of the set screws on the flat face of the motor shaft until the screw just touches the surface. Insert a bushing into the other set screw hole to prevent damage to the motor shaft. Then, tighten both set screws.

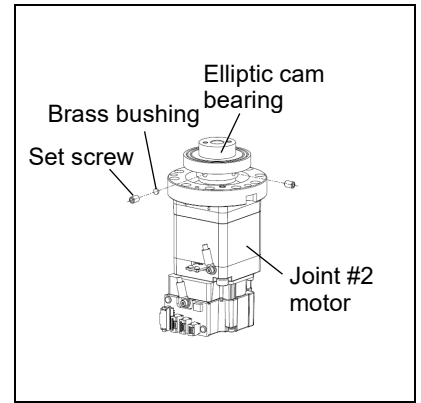

When using the elliptic cam positioning jig, unscrew the temporarily securing screws and remove the elliptic cam positioning jig.

 CAUTION	<ul style="list-style-type: none"> ■ Refer to the figure above for the orientation of the elliptic cam bearing. Be sure to mount the elliptic cam bearing properly. Improper mounting of the elliptic cam bearing will result in improper function of the Manipulator.
---	---

- (3) Mount the grease receiver to the elliptic cam bearing on the Joint #2 motor.
 - 2-M3×6+washer+collar
 - Tightening torque: $1 \pm 0.2 \text{ N}\cdot\text{m}$

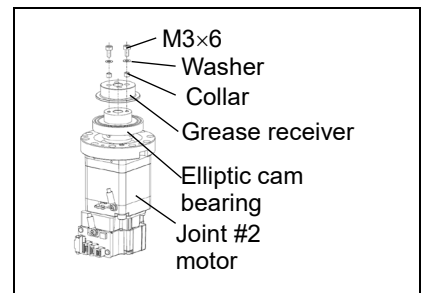

- (4) Apply grease.

Grease volume

- T3-B: Between the motor flange and the elliptic cam bearing
SFB No.1: 4g
- T6-B: Between the motor and the elliptic cam bearing
SFB No.1: 6g

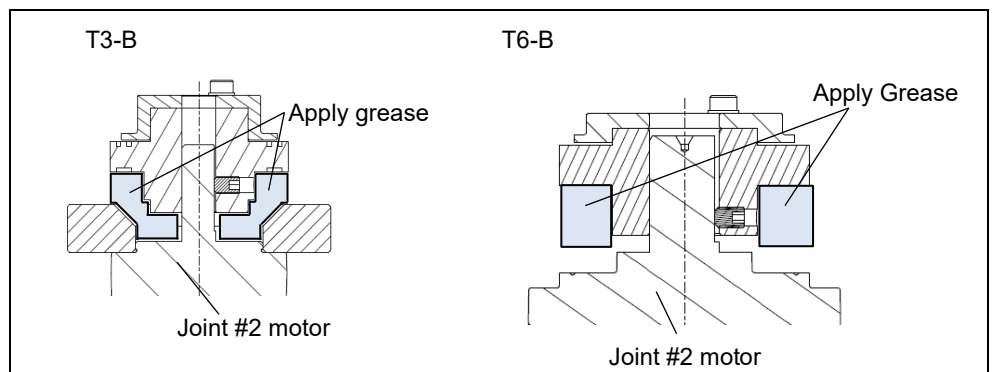

- (5) Secure temporarily the Joint #2 motor unit to Arm #2.

T3-B: Motor flange mounting screws

3-M4×12+washer

T6-B: Motor mounting screws

4-M4×12+washer

To insert the motor, slowly move the Arm #2 by hand and push in.

NOTE  Secure temporarily the screws. Perform an alignment of the reduction gear units in the next step.
Make sure that the screw head lightly touches the flange base

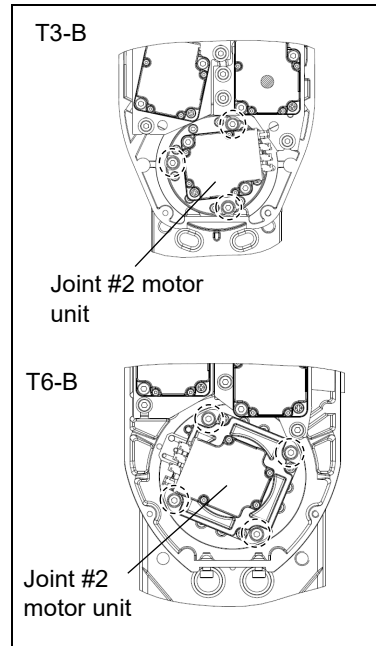

- (6) Perform an alignment of the reduction gear units.

Grab the grease receiver by hand and rotate the elliptic cam bearing three times clockwise. Then, rotate three times counterclockwise.

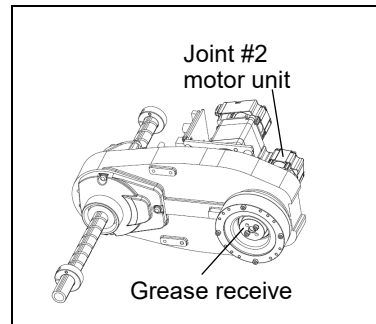

- (7) Tighten the motor mounting screws which secured temporarily to secure the motor.

Loosely fasten all bolts in a crisscross pattern so that the bolts will be fastened evenly.

T3-B: Motor flange mounting screws 3-M4×10

T6-B: Motor mounting screws 4-M4×12

Then, using a torque wrench, tighten each bolt securely in a crisscross pattern at the torque specified below.

Tightening torque: $4 \pm 0.2 \text{ N}\cdot\text{m}$

- (8) Mount Arm #2 and the reduction gear units to Arm #1.

Mount the O-ring (between the reduction gear units and Arm #1).

Replace O-ring to new one if there is swelling, scratch, or wear.

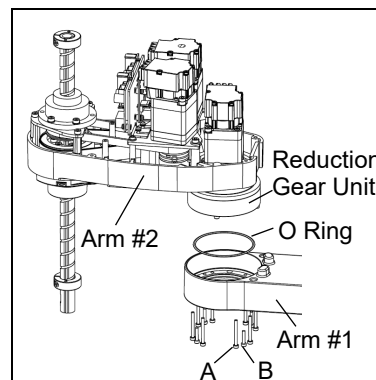

Tighten screws to mount Arm #2 and the reduction gear units to Arm #1.

Loosely fasten all bolts in a crisscross pattern so that the bolts will be fastened evenly.

T3-B: A: 8-M3×30+M3 small washer
B: 4-M3×15+M3 small washer

T6-B: A: 8-M3×32+8-M3 small washer
B: 4-M3×12+4-M3 small washer

Then, using a torque wrench, tighten each bolt securely in a crisscross pattern at the torque specified below.

Tightening torque: 2.5 ± 0.15 N·m

- (9) Mount the connector of the Joint #2 AMP board.

D: Motor cable connector

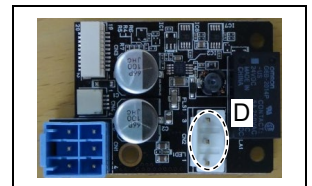

Mount the Joint # 2, 3, 4 AMP board unit to Arm #2.

2-M3×10 Sems

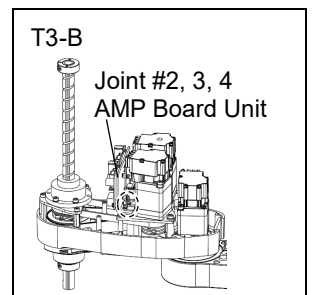

- (10) Mount the user plate.

Reference: 7.7 *User Plate*

- (11) Mount the Arm Top Cover.

Reference: 7.1 *Arm Top Cover*

- (12) Turn ON the Manipulator.

Reference: *T-B series Manual T3-B T6-B Manipulator 6.5 LED*

NOTE  When starting the Manipulator for the first time after replacing the motor unit, the motor unit firmware is automatically updated. DO NOT turn OFF the power until the Manipulator starts.

When you connect a motor unit connected to another axis, an error 5009 or 9709 will occur. To clear the error, enter the following command in [Command Window] and execute it.

```
Joint #1: > MUIDReset 1
Joint #2: > MUIDReset 2
Joint #3: > MUIDReset 3
Joint #4: > MUIDReset 4
```

Reboot the Controller.

- (13) Perform the calibration for the Joint #2.

Reference: 17. *Calibration*

10.2 Replacing Joint #2 Reduction Gear Units

A reduction gear unit consists of the following three parts. When replacing the reduction gear units, be sure to always replace the elliptic cam bearing, flex gear, and internal gear all together as one set.

For details of the parts, refer to “19. Maintenance Parts List”.

	Name		Quantity	Note
Maintenance part	Reduction gear units		1	T3-B: 1829508
				T6-B: 1829510
Tools	Hexagonal wrench	Width across flats: 2 mm	1	For M4 set screw
		Width across flats: 2.5 mm	1	For M3 screw
		Width across flats: 3 mm	1	For M4 screw
	Torque wrench		1	
	Cross-point screwdriver (No. 2)		1	For cross-recessed screw
	Spatula		1	For applying grease
	Wiping cloth		1	For wiping grease (Flange)
			1	For wiping grease (Bolt)
Grease	Grease	SFB No.1	-	

NOTE

A brake is mounted on the Joint #3 motor to prevent the shaft from lowering down due to the weight of the end effector while the power to the Manipulator is OFF or while the motor is in OFF status (MOTOR OFF).

Refer to removal steps to move the shaft down to its lower limit before the replacement procedure.

Joint #2 Reduction gear units Removal

- (1) Remove Arm #2 and the reduction gear units from Arm #1.

Reference: 10.1 Replacing Joint #2 Motor “Removal procedure”

- (2) Remove the elliptic cam bearing from the Joint #2 motor.

Reference: 10.1 Replacing Joint #2 Motor “Removal procedure”

Joint #2
Reduction
gear units
Installation

- (1) A new reduction gear unit contains the parts shown in the picture on the right when it is unpacked.

The internal gear, tooth grooves of the flex gear, and the elliptic cam bearing are pre-greased.

Wipe grease if it is attached to the mounting surface of the internal gear.

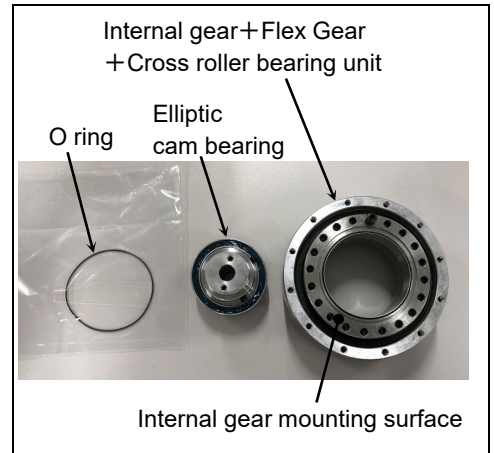

- (2) T3-B : Unscrew the temporarily securing screws (M3×4) of the internal gear.

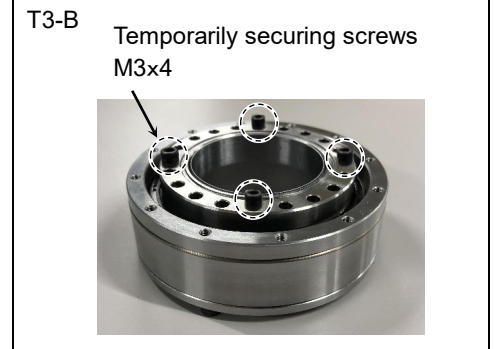

NOTE T6-B : Do not unscrew the securing screws (M3×4) of the internal gear.



- Never adjust (loosen or tighten) the mounting bolts between the flex gear and cross roller bearing unit.
- If the bolts are adjusted, it requires centering of the parts by the reduction gear unit manufacturer.

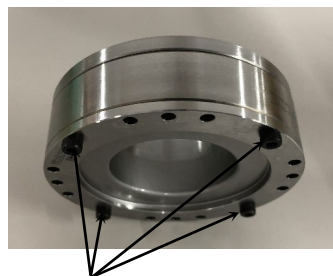

Do not loosen or tighten the 4 mounting bolts

- (3) Mount the O-ring to the grooves on the internal gear. (between reduction gear units and flange)

Make sure that the O-ring does not come out of the grooves.

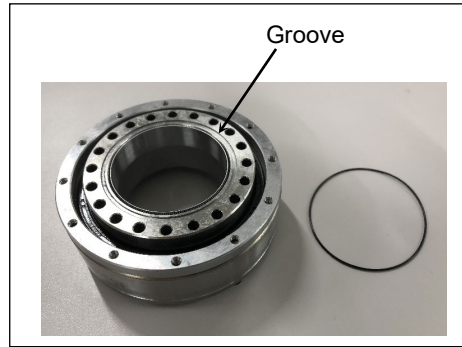

- (4) Mount the reduction gear units to Arm #2.

T3-B: 10-M3×18

T6-B: 16-M3×28

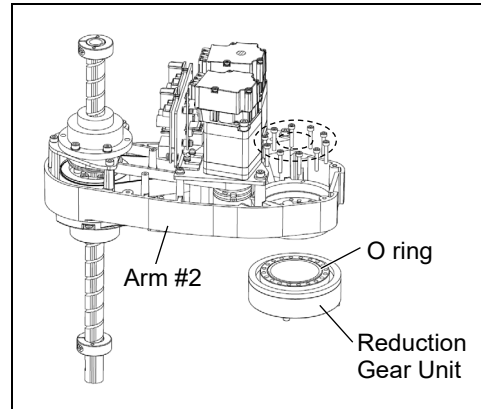

Loosely fasten all bolts in a crisscross pattern so that the bolts will be fastened evenly. Then, using a torque wrench, tighten each bolt securely in a crisscross pattern at the torque specified in the table below.

Name	Bolt type	Tightening torque
Joint #2 reduction gear units	M3	2.5±0.15N·m



NOTE Be careful not to apply too much force since it may damage the parts.

- (5) Mount the Joint #2 motor.

Reference: 10.1 Replacing Joint #2 Motor “Installation procedure”

11. Joint #3



- Do not connect or disconnect the motor connectors while the power to the robot system is turned ON. Connecting or disconnecting the motor connectors with the power ON is extremely hazardous and may result in serious bodily injury as the Manipulator may move abnormally, and also may result in electric shock and/or malfunction of the robot system.
- To shut off power to the robot system, disconnect the power plug from the power source. Be sure to connect the AC power cable to a power receptacle. DO NOT connect it directly to a factory power source.
- Before performing any replacement procedure, turn OFF the Controller and related equipment, and then disconnect the power plug from the power source. Performing any replacement procedure with the power ON is extremely hazardous and may result in electric shock and/or malfunction of the robot system.



- Be careful not to apply excessive shock to the motor shaft when replacing the motors. The shock may shorten the life cycle of the motors and encoder and/or damage them.
- Never disassemble the motor and encoder. A disassembled motor and encoder will cause a positional gap and cannot be used again.

After parts have been replaced (motors, reduction gear units, a brake, timing belts, ball screw spline unit, etc.), the Manipulator cannot operate properly because a mismatch exists between the origin stored in each motor and its corresponding origin stored in the Robot system.

Because of that, it is necessary to perform calibration (encoder rest and calibration) to match these origins.

Refer to “17. Calibration” to execute the calibration.

T3-B

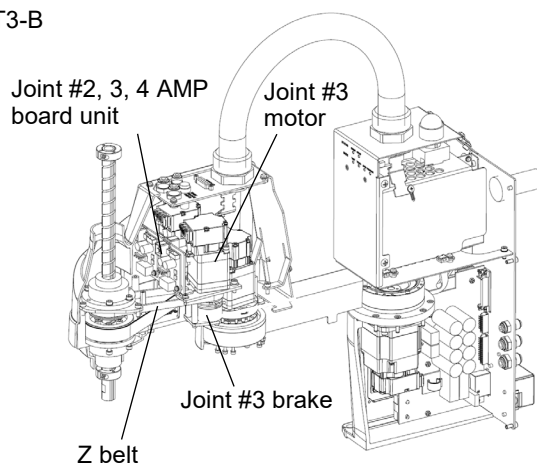

T6-B

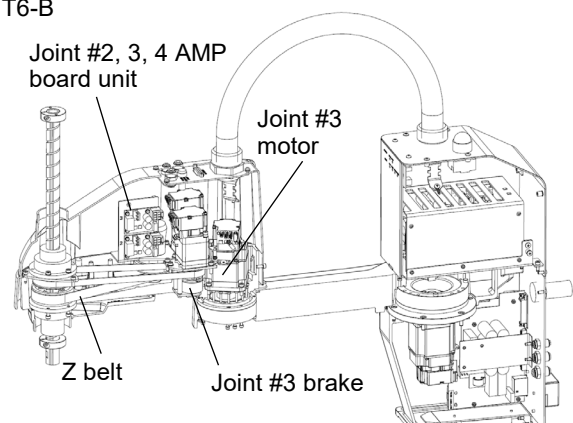

11.1 Replacing Joint #3 Motor

	Name		Quantity	Note
Maintenance part	Motor	100W	1	2216544
Tools	Hexagonal wrench	Width across flats: 1.5 mm	1	For M3 set screw and M2 screw
		Width across flats: 2.5 mm	1	For M5 set screw
		Width across flats: 3 mm	1	For M4 screw
	Torque wrench		1	
	Cross-point screwdriver (No. 2)		1	For cross-recessed screw
	Nippers		1	For cutting wire tie
	Force gage		1	Z: Belt tension 69N (7.0±0.5kgf)
	Suitable cord (Length about 800mm)		1	For belt tension
	Feeler gage (0.5mm)		2	For adjusting the pulley securing position
Material	Wire tie		-	

NOTE



A brake is mounted on the Joint #3 motor to prevent the shaft from lowering down due to the weight of the end effector while the power to the Manipulator is OFF or while the motor is in OFF status (MOTOR OFF).

Move the shaft down to its lower limit before the replacement procedure following the removal steps.

Joint #3 Motor Removal

- (1) Turn ON the Manipulator.
- (2) Press and hold the brake release switch to let the shaft down. Be sure to keep enough space and prevent the end effector hitting any peripheral equipment.

The brake release switch affects only Joint #3. When the brake release switch is pressed, the Joint #3 brake is released.

Be careful of the shaft falling while the brake release switch is being pressed because the shaft may be lowered by the weight of the end effector.

- (3) Turn OFF the Manipulator.
- (4) Remove the arm top cover.

Reference: 7.1 *Arm Top Cover*
- (5) Cut off the wire tie binding the brake cables.

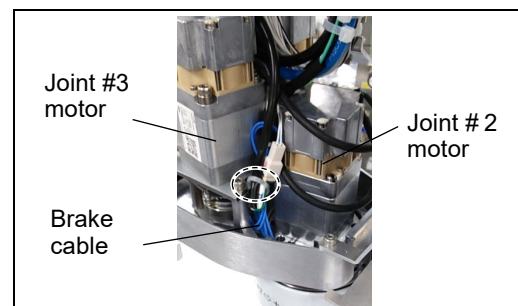

- (6) T6-B : Cut off the wire tie (×2) binding the motor cables of Joint #3.

Wire tie for A and B

Wire tie for A and C

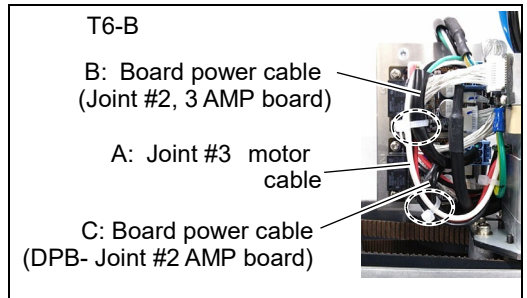

- (7) Remove the user plate.

Reference: 7.7 User Plate

- (8) Remove the connector of the Joint #3 motor unit.

A: AMP cable connector (×1)

B: Signal cable connector (IN/OUT ×1 for each)

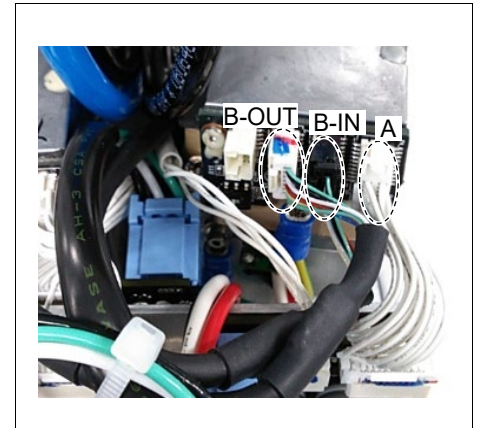

- (9) Loosen the mounting screws of the Joint #2, 3, 4 AMP board unit, and remove the board unit from Arm #2.

Sems bolt: 2-M3×10

Remove the following connectors from AMP board unit.

A: Power cable connector (×3)

B: AMP cable connector (×3)

C: Motor cable connector (×3)

D: Brake cable connector (×1)

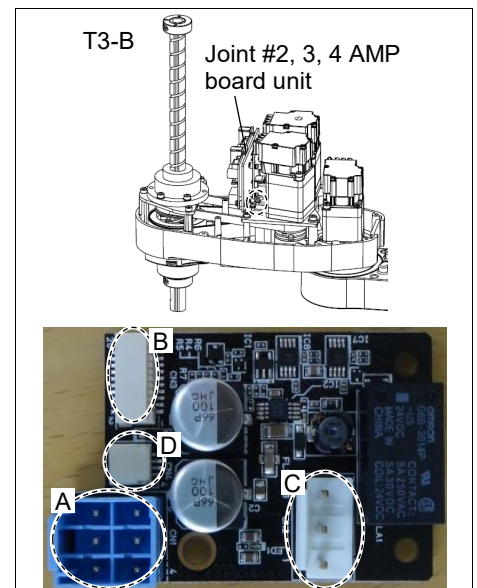

(10) Remove the bolt and the washer mounting the Joint #3 motor unit.

T3-B: a: 2-M4×15+M4 slotted hole washer
 b: M3×12+M3 slotted hole washer

T6-B: ab: 3-M4×15+M4 washer

NOTE The washer will be necessary again when mounting Z belt. Be sure not to lose them.

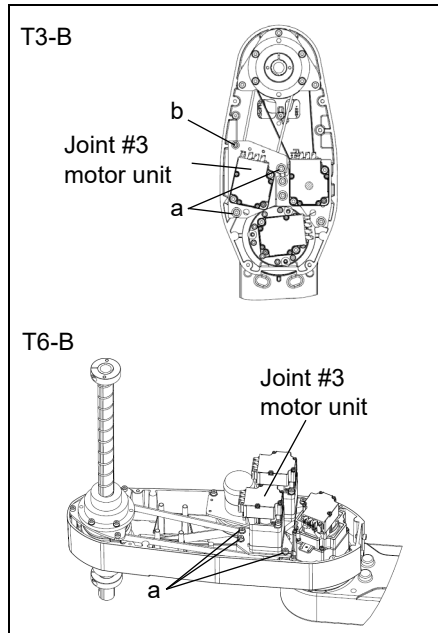

(11) Pulley carries the belt. Tilt Joint #3 motor little and pull it up with avoiding the belt. Then remove the motor.

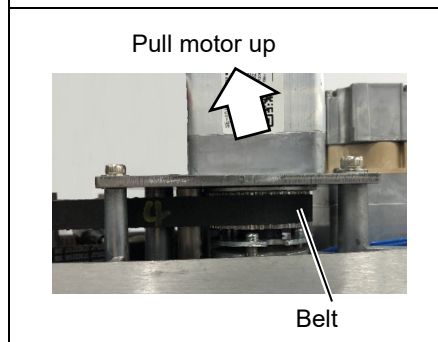

(12) T3-B : Remove the motor plate from Joint #3 motor unit.

2-M4×55

2- collar $\varnothing 7 \times$ thickness 4

The collar will be necessary again when mounting motor belt. Be sure not to lose them.

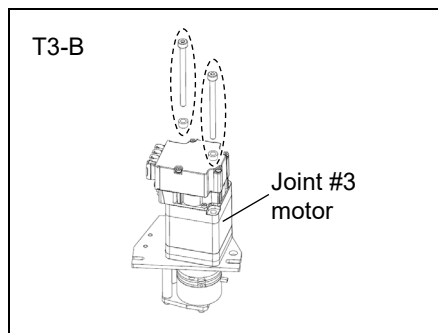

T6-B : Remove the posts and the brake.

2-M3×50

The posts, brake, and brake plate will be necessary again. Be sure not to lose them.

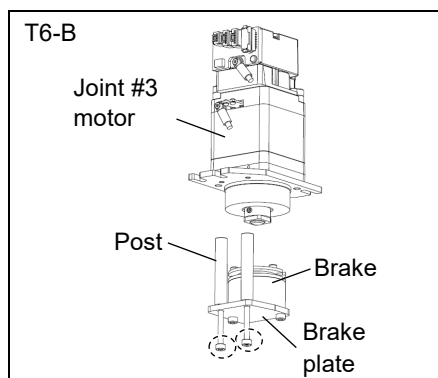

(13) Loosen the screws of the pulley and brake hub and remove them from the Joint #3 motor.

- a: M5×8 set screw
- b: M5×8 set screw+M5 bushing
- c: T3-B: M3×3 set screw
T6-B: M3×4 set screw
- d: T3-B: M3×3 set screw+M3 bushing
T6-B: M3×4 set screw+M3 bushing
- e: T3-B: washer
(external diameter: $\varnothing 14$, internal diameter: $\varnothing 8$, thickness: 0.5)

There is a brass bushing in one of the set screw holes. Be sure not to lose the bushing.

NOTE For T3-B only:



There is a washer between the pulley and the brake hub. Be sure not to lose the washer.

(14) For T6-B only:

Remove the motor plate from Joint #3 motor unit.

- 2-M4×55
- 2- collar $\varnothing 7 \times$ thickness 4

NOTE The collar will be necessary again when mounting motor plate. Be sure not to lose them.

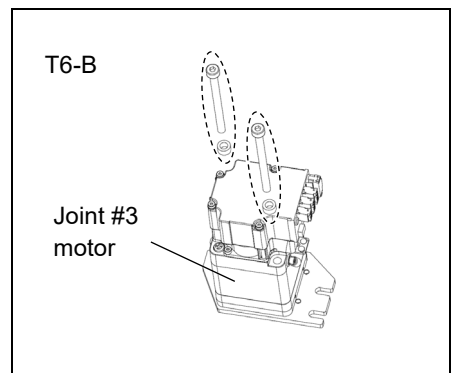
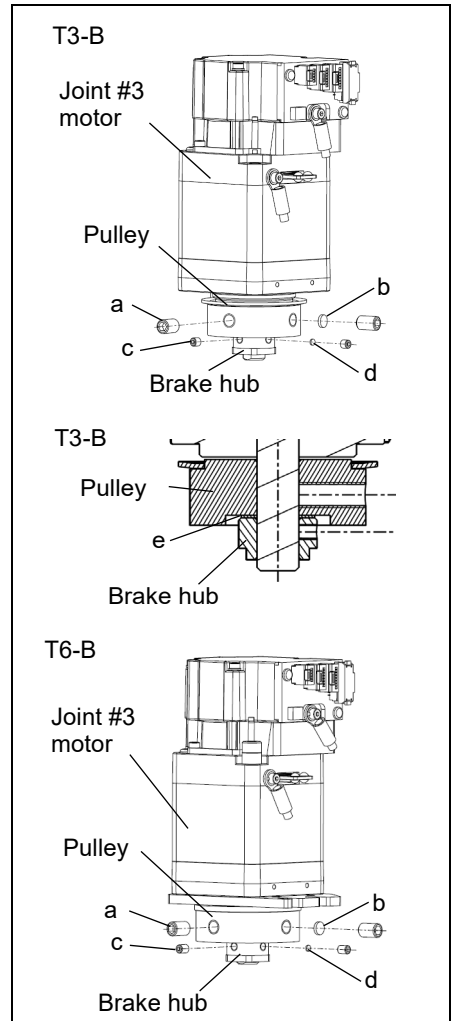

Joint #3
Motor
Installation

NOTE  For tightening hexagon socket head cap bolts, refer to “2.4 Tightening Hexagon Socket Head Cap Bolts”.

- (1) For T6-B only:
Mount the Joint #3 motor to the motor plate.

- 2-M4×55
- 2- collar $\varnothing 7 \times$ thickness 4
- Tightening torque: $4 \pm 0.2 \text{ N}\cdot\text{m}$

NOTE  When mounting the motor plate, be careful of the positions of the motor plate and the motor.

- (2) T3-B : Mount the pulley and brake hub to the
Joint #3 motor.

- a: M5×8 set screw
- b: M5×8 set screw+M5 bushing
- c: M3×3 set screw
- d: M3×3 set screw+M3 bushing
- e: washer
(external diameter: $\varnothing 14$, internal diameter: $\varnothing 8$, thickness: 0.5)

Tightening torque:
M3 set screw: $0.9 \pm 0.1 \text{ N}\cdot\text{m}$
M5 set screw: $4 \pm 0.2 \text{ N}\cdot\text{m}$

NOTE  There is a washer (thickness: 0.5mm) between the pulley and the brake hub.

Secure the pulley and the motor so that the clearance will be 0.5mm.

NOTE  Be sure to make the clearance (0.5mm) between the pulley and the motor.

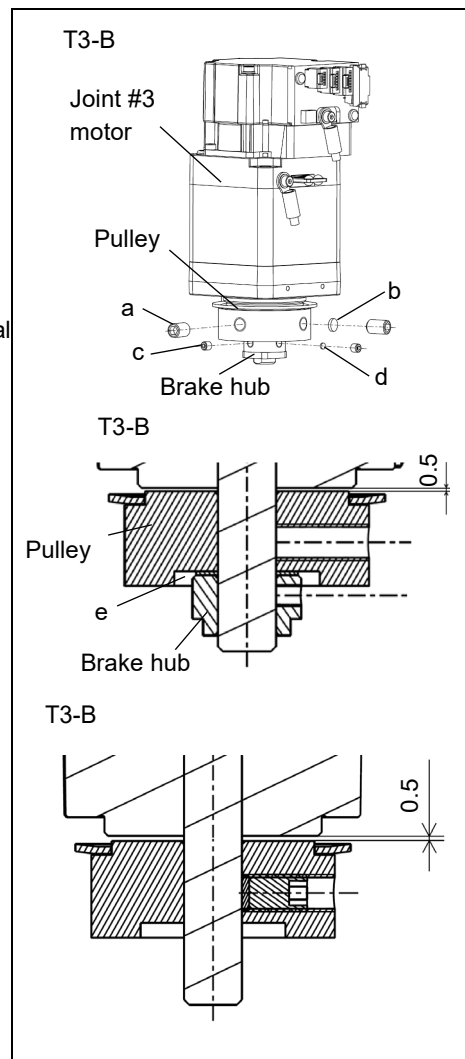
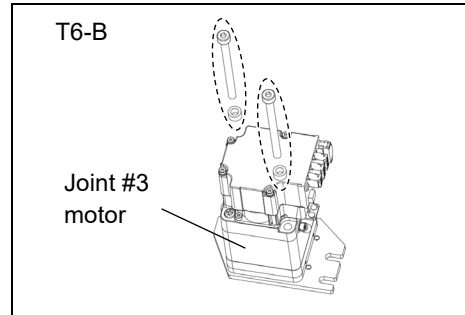

T6-B : Mount the pulley and brake hub to the Joint #3 motor.

- a: M5×8 set screw
 - b: M5×8 set screw+M5 bushing
 - c: M3×4 set screw
 - d: M3×4 set screw+M3 bushing
- Tightening torque:
 M3 set screw: $0.9 \pm 0.1 \text{ N}\cdot\text{m}$
 M5 set screw: $4 \pm 0.2 \text{ N}\cdot\text{m}$

Secure the pulley and the motor plate so that the clearance will be 0.5mm.

NOTE  Be sure to make the clearance (0.5mm) between the motor plate and the pulley with mounting the motor plate.

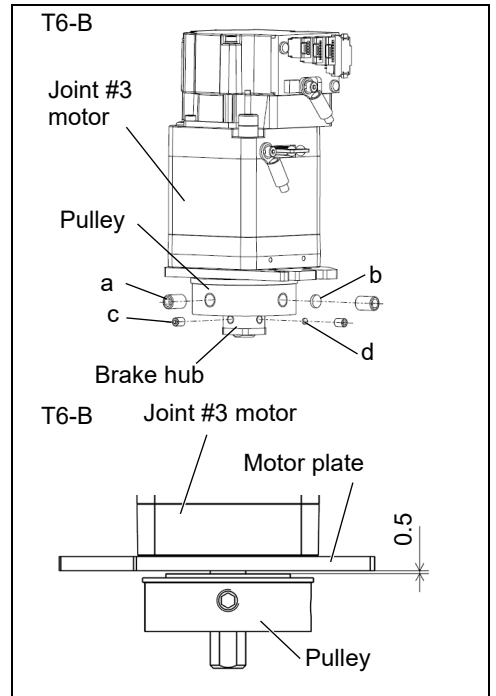

Mount the brake hub until it hits the pulley, and secure it at the position where it contacts the end face of the pulley.

Tighten one of the set screws on the flat face of the motor shaft until the screw just touches the surface.

Insert a bushing into the other set screw hole to prevent damage to the motor shaft. Then, tighten both set screws.

(3) T3-B : Mount the Joint #3 motor to the motor plate.

- 2-M4×55
- 2- collar $\phi 7 \times$ thickness 4

Fit the brake disk to the hub.

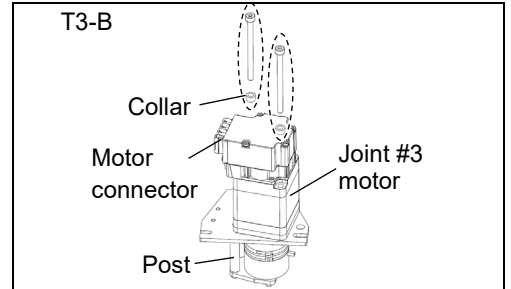

NOTE  When mounting the motor plate, be careful of the positions of the motor plate and the motor. Check the direction according to the positional relationship of the motor connector and the posts.

T6-B : Mount the posts, brake, and brake plate to the motor plate.

2-M3×45

Fit the brake disk to the hub.

When mounting the brake plate, be careful of the direction of the brake , brake plate, and the motor.

Apply the following torque to secure the plate.

Tightening torque: 2 ± 0.1 N·m

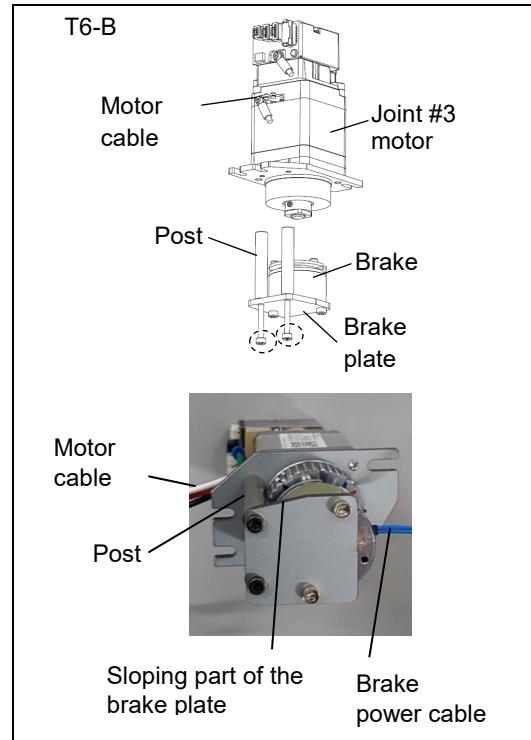

(4) Mount the motor unit to Arm #2

When passing the belt, make sure that the belt does not out of the pulley.

Mount the motor cables facing to front of the arm.

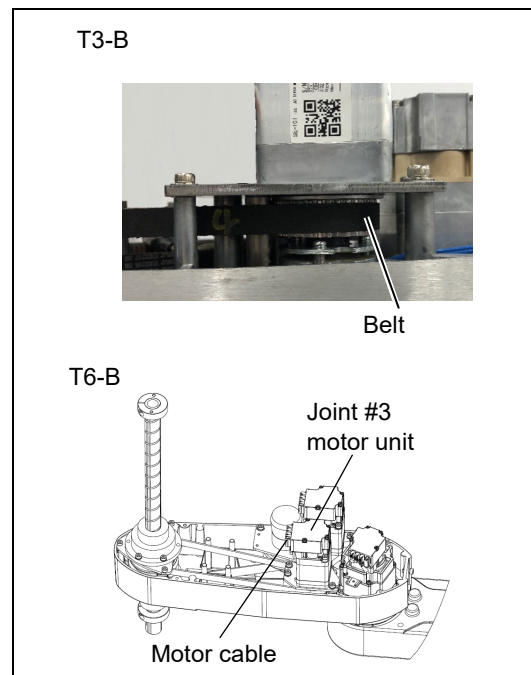

(5) Secure temporarily the Joint #3 motor unit to Arm #2.

NOTE  Check that the motor unit can be moved by hand, and it will not tilt when pulled. If the unit is secured too loose or too tight, the belt will not have the proper tension.

- (6) Apply the proper tension to the Z belt, and secure the Joint #3 motor unit.

T3-B: a: 2-M4×15+M4 slotted hole washer
 b: M3×12+M3 slotted hole washer

T6-B: ab: 3-M4×15+M4 washer

Pass a suitable cord or string around the plate hole of the Joint #3 motor unit. Then, pull the cord using a force gage or similar tool to apply the specified tension shown below.

Z belt tension:
 34.5 N (3.5 ± 0.5 kgf)

Axial force (when pulling):
 69.0 N (7.0 ± 0.5 kgf)

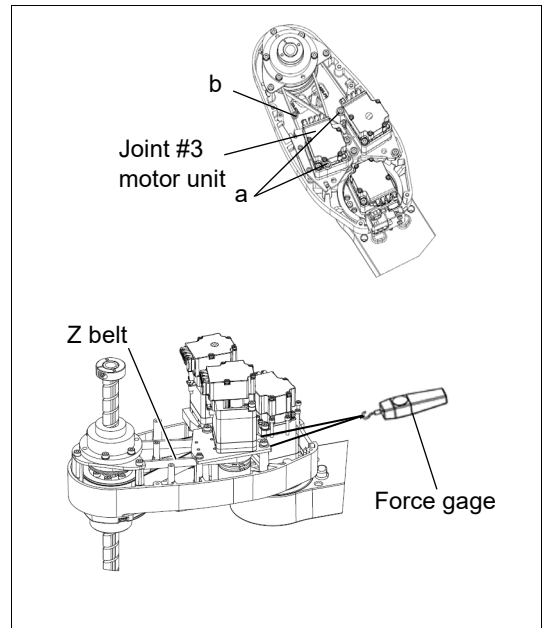

Apply the following torque to secure the plate.

M3: 2 ± 0.1 N·m

M4: 4 ± 0.2 N·m

NOTE To check belt tension with the tension meter, refer to the following.



11.4 Checking the Timing Belt Tension (Z Belt)

- (7) Mount the Joint # 2, 3, 4 AMP board unit.

Sems bolt: 2-M3×10

Tightening torque: 0.9 ± 0.05 N·m

Connect the following connectors to the AMP board unit.

- A: Power cable connector (×3)
- B: AMP cable connector (×3)
- C: Motor cable connector (×3)
- D: Brake cable connector (×1)

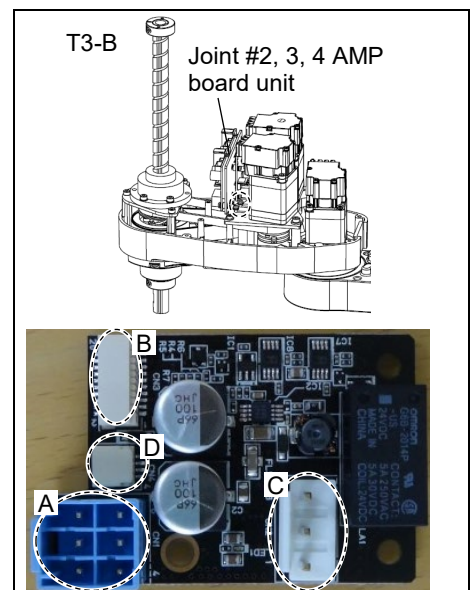

- (8) Connect the connector of Joint #3 motor unit.

- A: AMP cable connector (×1)
- B: Signal cable connector (IN/OUT ×1 for each)

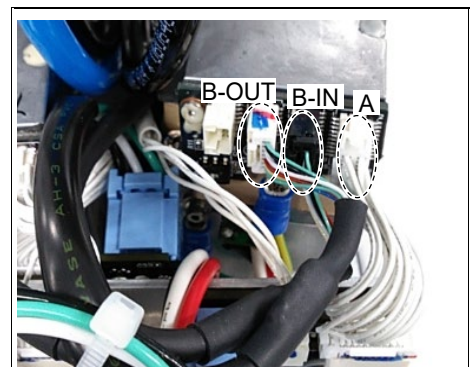

(9) Mount the user plate.

Reference: 7.7 *User Plate*

(10) Bind the brake cables with a wire tie as worked in the removal procedure (5).

(11) Bind the motor cable and the AMP board power cable with wire tie (×2) as worked in the removal procedure (6).

NOTE



Bind the cable and belt apart so that the cable does not touch the Z belt.

(12) Mount the arm top cover.

Reference: 7.1 *Arm Top Cover*

(13) Turn ON the Manipulator.

Reference: *T-B series Manual T3-B T6-B Manipulator 6.5 LED*

NOTE



When starting the Manipulator for the first time after replacing the motor unit, the motor unit firmware is automatically updated. DO NOT turn OFF the power until the Manipulator starts.

When you connect a motor unit connected to another axis, an error 5009 or 9709 will occur. To clear the error, enter the following command in [Command Window] and execute it.

```
Joint #1: > MUIIDReset 1  
Joint #2: > MUIIDReset 2  
Joint #3: > MUIIDReset 3  
Joint #4: > MUIIDReset 4
```

Reboot the Controller.

(14) Perform the calibration of Joints #3, #4.

Reference: 17. *Calibration*

11.2 Replacement of the timing belt

	Name	Quantity	Note	
Maintenance part	Z belt	Width: 9 mm	1	T3-B: 1554773
		Width: 10 mm	1	T6-B: 1563316
Tools	Hexagonal wrench	Width across flats: 2.5 mm	1	For M3 screw
		Width across flats: 3 mm	1	For M4 screw
	Torque wrench		1	
	Cross-point screwdriver (No. 2)		1	For cross-recessed screw
	Force gage		1	Z: Belt tension 69N (7.0±0.5kgf)
	Suitable cord (Length about 800mm)		1	For belt tension
Material	Wire tie	-		



A brake is mounted on the Joint #3 motor to prevent the shaft from lowering down due to the weight of the end effector while the power to the Manipulator is OFF or while the motor is in OFF status (MOTOR OFF).

Refer to removal steps to move the shaft down to its lower limit before the replacement procedure.

Z belt Removal

- (1) Remove the Joint #3 motor unit.

Reference: 11.1 Replacing Joint #3 Motor “Joint #3 motor Removal”

- (2) Unscrew the spline plate mounting screws.

3-M4×12

Holding the spline plate upward, pull out the Z belt.

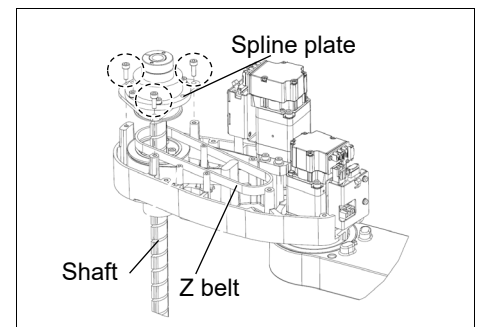

Z belt Installation

- (1) Pass a new Z belt through the shaft.
- (2) Lower the spline plate with the Z belt placed around the spline plate pulley. Secure the spline plate with three screws.

Secure temporarily the spline plate on the Arm #2 and move the shaft up and down several times before securing the spline plate.

- (3) Mount the Joint #3 motor unit.

Reference: 11.1 Replacing Joint #3 Motor “Joint #3 motor Installation”

11.3 Replacing the Brake

	Name	Quantity	Note	
Maintenance part	Solenoid brake unit	1	1875188	
Tools	Hexagonal wrench	Width across flats: 2 mm	1	For M2.5 screw
		Width across flats: 2.5 mm	1	For M3 screw
		Width across flats: 3 mm	1	For M4 screw
		Width across flats: 4 mm	1	For M5 screw
	Torque wrench	1		
	Cross-point screwdriver (No. 2)	1	For cross-recessed screw	
	Force gage	1	Z: Belt tension 69N (7.0±0.5kgf)	
	Suitable cord (Length about 800mm)	1	For belt tension	
Material	Wire tie	-		



A brake is mounted on the Joint #3 motor to prevent the shaft from lowering down due to the weight of the end effector while the power to the Manipulator is OFF or while the motor is in OFF status (MOTOR OFF).

Move the shaft down to its lower limit before the replacement procedure following the removal steps.

**Joint #3
Brake
Removal**

- (1) Remove the Joint #3 motor unit.

Reference: 11.1 Replacing Joint #3 Motor “Joint #3 motor Removal”

- (2) Remove the brake from the brake plate.

2-M3×8

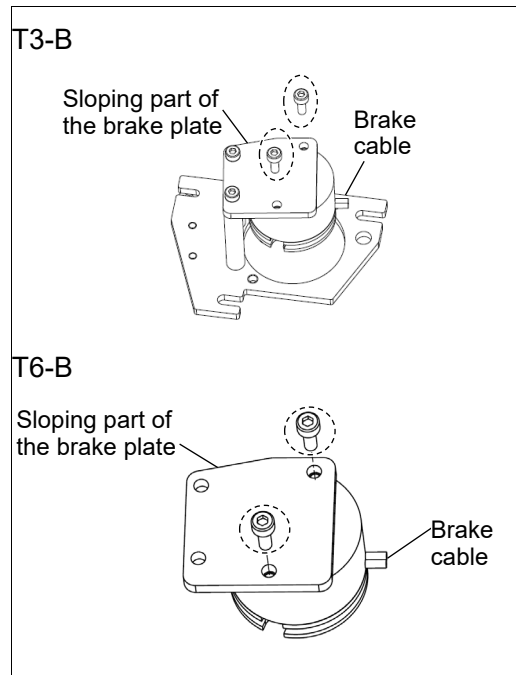

**Joint #3
Brake
Installation**

- (1) Mount the brake on the brake plate.

2-M3×8

Tightening torque: 2 ± 0.1 N·m



Be careful of the direction of the sloping part of the brake plate and the brake cable when mounting it.

- (2) Mount the Joint #3 motor unit and the solenoid brake.

Reference: 11.1 Replacing Joint #3 Motor “Joint #3 motor Installation”

11.4 Checking the Timing Belt Tension (Z Belt)

	Name	Quantity	Note
Tools	Sonic tension meter	1	For details of usage and measurement methods of the tension meter, refer to the instruction manual of the tension meter.

Joint #3
Belt tension
check

- (1) Enter appropriate setting values to the sonic tension meter.

Model	Belt	Unit weight M [g/(1 mm width × 1 m length)]	Width W [mm]	Span S [mm]
T3-B	Z belt	1.9	9	127
T6-B	Z belt	1.9	10	212

- (2) Flip the belt and measure the tension.



NOTE Measurement failure may occur if the microphone touches the belt during measurement.

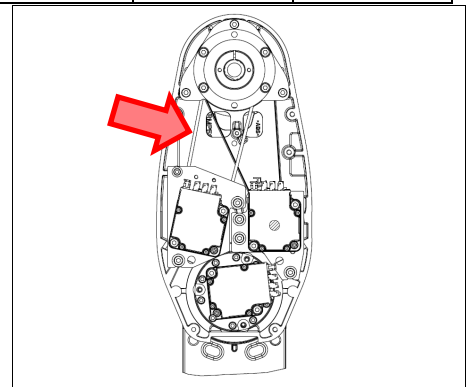

12. Joint #4

 WARNING	<ul style="list-style-type: none"> ■ Do not connect or disconnect the motor connectors while the power to the robot system is turned ON. Connecting or disconnecting the motor connectors with the power ON is extremely hazardous and may result in serious bodily injury as the Manipulator may move abnormally, and also may result in electric shock and/or malfunction of the robot system. ■ To shut off power to the robot system, disconnect the power plug from the power source. Be sure to connect the AC power cable to a power receptacle. DO NOT connect it directly to a factory power source. ■ Before performing any replacement procedure, turn OFF the Controller and related equipment, and then disconnect the power plug from the power source. Performing any replacement procedure with the power ON is extremely hazardous and may result in electric shock and/or malfunction of the robot system.
--	---

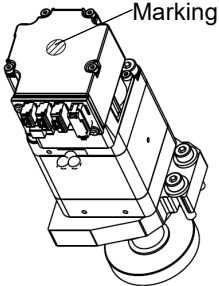
 CAUTION	<ul style="list-style-type: none"> ■ Be careful not to apply excessive shock to the motor shaft when replacing the motors. The shock may shorten the life cycle of the motors and encoder and/or damage them. ■ Do not mount Joint #4 motor unit on the other joints since specification is different from that of Joint #2 or #3 motor units. Marking is applied on the motor case of Joint #4 motor. 	
<ul style="list-style-type: none"> ■ Never disassemble the motor and encoder. A disassembled motor and encoder will cause a positional gap and cannot be used again. 		

After parts have been replaced (motors, reduction gear units, a brake, timing belts, ball screw spline unit, etc.), the Manipulator cannot operate properly because a mismatch exists between the origin stored in each motor and its corresponding origin stored in the Robot system.

Because of that, it is necessary to perform calibration (encoder rest and calibration) to match these origins.

Refer to “17. Calibration” to execute the calibration.

T3-B

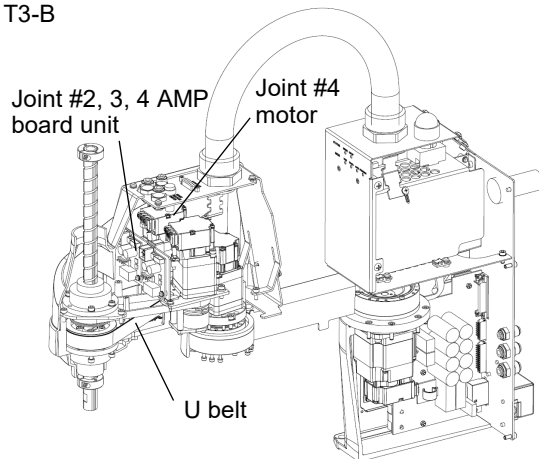

T6-B

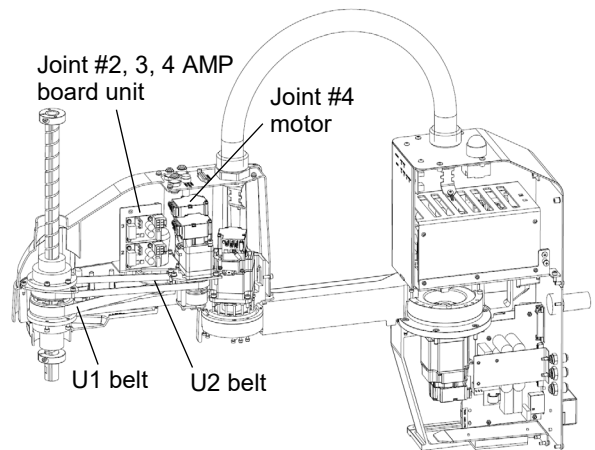

12.1 Replacing Joint #4 Motor

	Name		Quantity	Note
Maintenance part	Motor	100W	1	2216545
Tools	Hexagonal wrench	Width across flats: 2 mm	1	For M4 set screw
		Width across flats: 3 mm	1	For M4 screw
	Torque wrench		1	
	Cross-point screwdriver (No. 2)		1	For cross-recessed screw
	Force gage		1	U: Belt tension 69 N (7.0 ± 0.5 kgf)
	Suitable cord (Length about 800mm)		1	For belt tension

 CAUTION	<p>■ The belt must be installed with proper tension; otherwise the following problems may occur.</p> <p>If falling below the lower limit : Jumping of the belt gears (position gap)</p> <p>If exceeding the upper limit : Abnormal noise or vibration (oscillation), decline in the life of driving parts</p>
---	---

NOTE

A brake is mounted on the Joint #3 motor to prevent the shaft from lowering down due to the weight of the end effector while the power to the Manipulator is OFF or while the motor is in OFF status (MOTOR OFF).

Move the shaft down to its lower limit before the replacement procedure following the removal steps.

Joint #4
 Motor
 Removal

- (1) Turn ON the Manipulator.
- (2) Press and hold the brake release switch to let the shaft down. Be sure to keep enough space and prevent the end effector hitting any peripheral equipment.

NOTE
 The brake release switch affects only Joint #3. When the brake release switch is pressed, the Joint #3 brake is released.

Be careful of the shaft falling while the brake release switch is being pressed because the shaft may be lowered by the weight of the end effector.

- (3) Turn OFF the Manipulator.
- (4) Remove the arm top cover.

Reference: 7.1 *Arm Top Cover*

- (5) Remove the user plate.

Reference: 7.7 *User Plate*

- (6) Remove the connector of the Joint #4 motor unit.

A: AMP cable connector (×1)

B: Signal cable connector
(IN only: ×1)

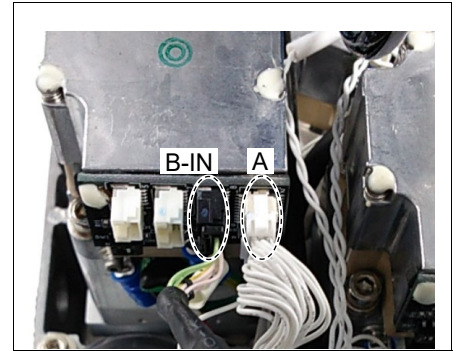

- (7) Loosen the mounting screws of the Joint #2, 3, 4 AMP board unit, and remove the board unit from Arm #2.

Sems bolt: 2-M3×10

Remove the following connectors from AMP board unit.

A: Power cable connector (×3)

B: AMP cable connector (×3)

C: Motor cable connector (×3)

D: Brake cable connector (×1)

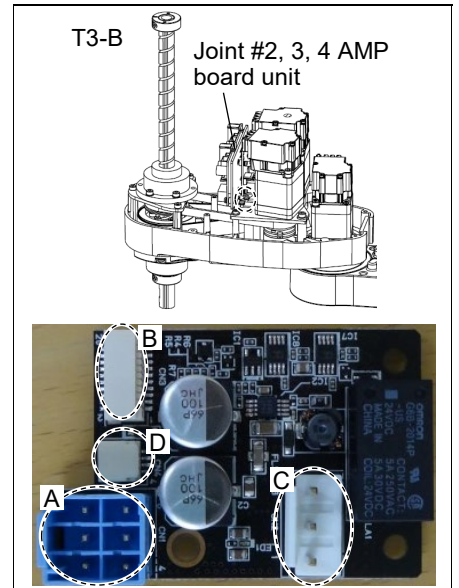

- (8) Remove the Joint #4 motor unit from Arm #2.

Remove the bolts securing the Joint #4 motor on the motor plate and pull out the motor.

T3-B: 3-M4x20+M4 slotted hole washer

T6-B: 3-M4x20+M4 washer

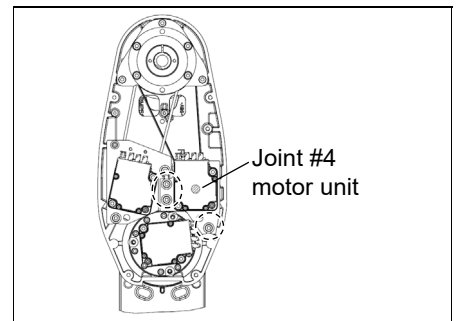

Pulley carries the belt. Tilt Joint #4 motor little and pull it up with avoiding the belt when removing the motor.

NOTE

The washer will be necessary again when mounting U belt. Be sure not to lose them.

- (9) Remove the screws and washers for bearing shaft from the Joint #4 motor.

T3-B: 2-M4x8
 2- washer
 (external diameter: $\varnothing 12$, internal diameter: $\varnothing 4.2$, thickness: 0.5 mm)

T6-B: 2-M3x6
 2- washer
 (external diameter: $\varnothing 10$, internal diameter: $\varnothing 3.3$, thickness 0.5 mm)

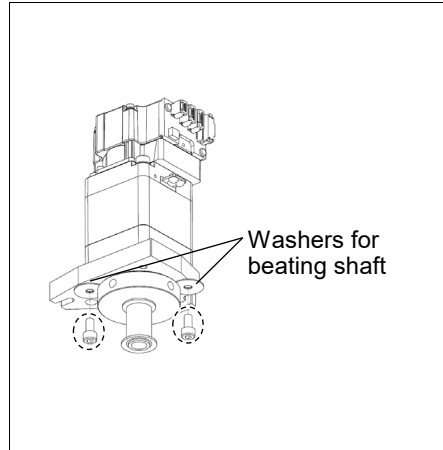

NOTE The washer will be used again. Be sure not to lose them.



- (10) Remove the pulley and the bearing from the Joint #4 motor.

M4x8 set screw
 M4x8 set screw+M4 bushing

NOTE There is a brass bushing in the set screw holes. Be sure not to lose the bushing.

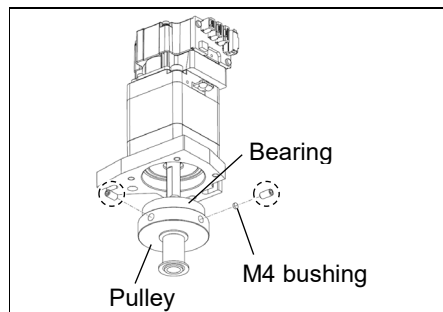

- (11) Remove the motor plate from the Joint #4 motor.

2-M4x55 +M4 small washer

NOTE The washer will be necessary again when mounting motor plate. Be sure not to lose them.

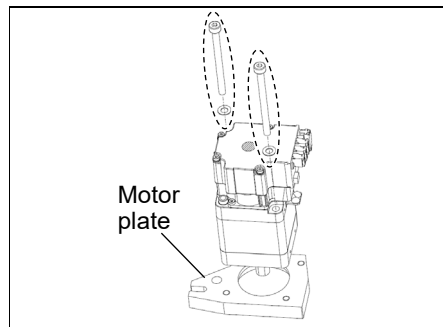

Joint #4
Motor
Installation

- (1) Mount temporarily the motor plate on the Joint #4 motor.
2-M4×55 +M4 small washer

When mounting temporarily the motor plate, be careful of the positions of the motor plate and the motor.

NOTE  Check that the motor can be moved by hand, and it will not tilt when pulled.

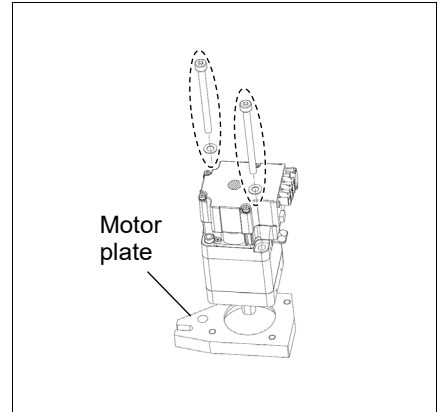

- (2) Mount the pulley and the bearing on the Joint #4 motor.

- M4×8 set screw
- M4×8 set screw+M4 bushing

Tighten one of the set screws and bushing vertically on the flat face of the motor shaft. Secure using the set screw and the bushing while preventing damage to the motor shaft.

NOTE  Make sure that the bearing is inserted completely when mounting the pulley. If the end faces of the motor plate and bearing fit, bearing is inserted completely.

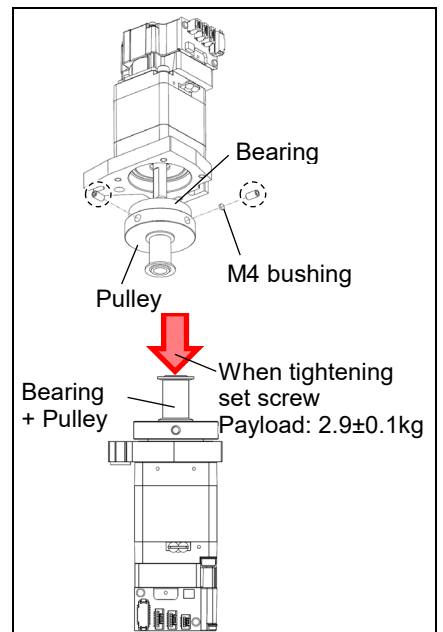

Give a pressure to bearing when tightening.

Pressure: $2.9 \pm 0.1 \text{ kg}$

Apply the following torque to secure the pulley.

Tightening torque: $2.5 \pm 0.15 \text{ N}\cdot\text{m}$

- (3) Mount the motor plate on the Joint #4 motor.

T3-B: 3-M4x20+M4 slotted hole washer

T6-B: 3-M4x20+M4 washer

Tightening torque: $4 \pm 0.2 \text{ N}\cdot\text{m}$

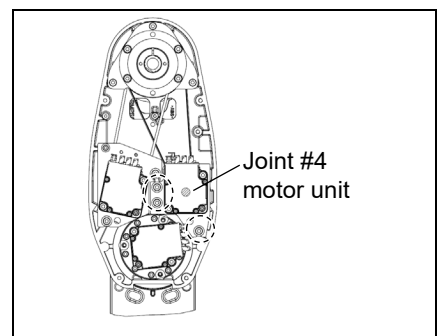

- (4) Mount the screws and washers for bearing shaft on the Joint #4 motor.

Tightening torque:

M3: $2 \pm 0.1 \text{ N}\cdot\text{m}$

M4: $2.5 \pm 0.15 \text{ N}\cdot\text{m}$

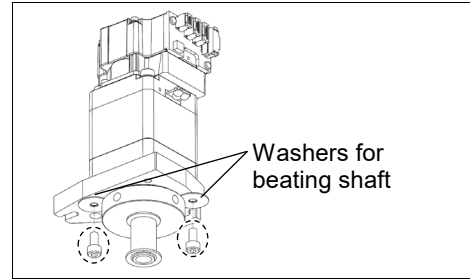

T3-B: 2-M4x8

2- washer: (external diameter: $\phi 12$, internal diameter: $\phi 4.2$, thickness: 0.5 mm)

T6-B: 2-M3x6

2- washer: (external diameter: $\phi 10$, internal diameter: $\phi 3.3$, thickness: 0.5 mm)

- (5) Place the pulley around the U belt and secure temporarily the Joint #4 motor unit to Arm #2.

NOTE



Check that the motor unit can be moved by hand, and it will not tilt when pulled. If the unit is secured too loose or too tight, the belt will not have the proper tension. Make sure the gear grooves of the belt are fit into those of the pulleys completely.

- (6) Apply the proper tension to the U belt, and secure the Joint #4 motor unit.

T3-B: 3-M4x20+M4 slotted hole washer

T6-B: 3-M4x20+M4 washer

Pass a suitable cord or string around the plate hole of the Joint #4 motor unit. Then, pull the cord using a force gage or similar tool to apply the specified tension shown below.

U belt tension:

T3-B: 34.5 N ($3.5 \pm 0.5 \text{ kgf}$)

T6-B: 29.0 N ($3.0 \pm 0.5 \text{ kgf}$)

Axial force (when pulling):

T3-B: 69.0 N ($7 \pm 0.5 \text{ kgf}$)

T6-B: 58.0 N ($5.9 \pm 0.5 \text{ kgf}$)

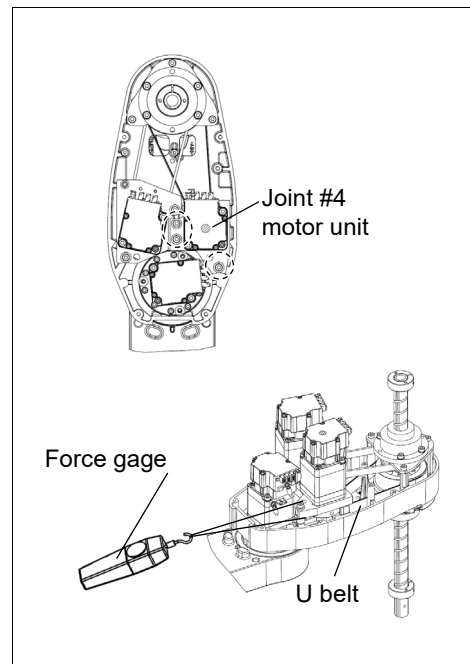

Apply the following torque to secure the plate.

Tightening torque: $4 \pm 0.2 \text{ N}\cdot\text{m}$

NOTE



To check belt tension with the tension meter, refer to the following.

12.3 Checking the Timing Belt Tension (U Belt)

- (7) Mount the Joint # 2, 3, 4 AMP board unit.

Sems bolt: 2-M3×10

Connect the following connectors to the AMP board unit.

- A: Power cable connector (×3)
 B: AMP cable connector (×3)
 C: Motor cable connector (×3)
 D: Brake cable connector (×1)

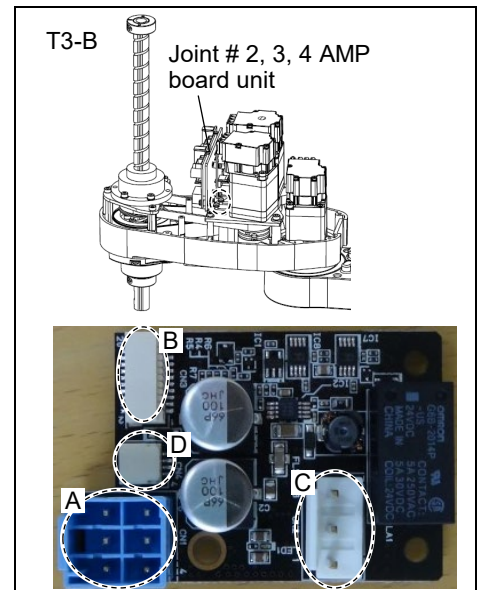

- (8) Mount the connector of the Joint #4 motor unit.

- A: AMP cable connector (×1)
 B: Signal cable connector
 (IN only: ×1)

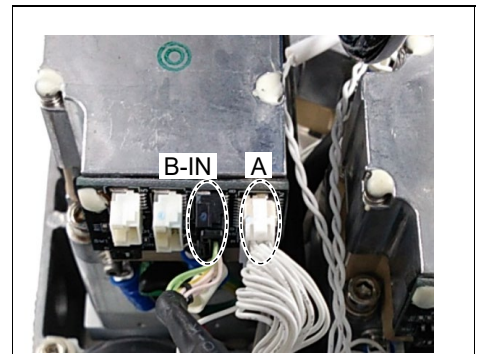

- (9) Mount the user plate.

Reference: 7.7 *User Plate*

- (10) Mount the arm top cover.

Reference: 7.1 *Arm Top Cover*

- (11) Turn ON the Manipulator.

Reference: *T-B series Manual T3-B T6-B Manipulator 6.5 LED*

When starting the Manipulator for the first time after replacing the motor unit, the motor unit firmware is automatically updated. DO NOT turn OFF the power until the Manipulator starts.

When you connect a motor unit connected to another axis, an error 5009 or 9709 will occur. To clear the error, enter the following command in [Command Window] and execute it.

```
Joint #1: > MUIReset 1
Joint #2: > MUIReset 2
Joint #3: > MUIReset 3
Joint #4: > MUIReset 4
```

Reboot the Controller.

- (12) Perform the calibration of Joints #3, #4.

Reference: 17. *Calibration*

12.2 Replacement of the timing belt

	Name		Quantity	Note
Maintenance part	U belt	Width: 17 mm	1	T3-B: 1709608
	U1 belt	Width: 10 mm	1	T6-B: 1674797
	U2 belt	Width: 15 mm	1	T6-B: 1674798
Tools	Hexagonal wrench	Width across flats: 2.5 mm	1	For M3 screw
		Width across flats: 3 mm	1	For M4 screw
	Torque wrench		1	
	Cross-point screwdriver (No. 2)		1	For cross-recessed screw
	Force gage		1	Tension U: 69N (7.0±0.5 kgf) U1: 58N (5.9±0.5 kgf) U2: 102 N (10.4 ± 0.75 kgf)
	Suitable cord (Length about 800 mm)		1	For belt tension

 CAUTION	<p>■ The belt must be installed with proper tension; otherwise the following problems may occur.</p> <p>If falling below the lower limit : Jumping of the belt gears (position gap)</p> <p>If exceeding the upper limit : Abnormal noise or vibration (oscillation), decline in the life of driving parts</p>
--	---

NOTE  A brake is mounted on the Joint #3 motor to prevent the shaft from lowering down due to the weight of the end effector while the power to the Manipulator is OFF or while the motor is in OFF status (MOTOR OFF).

Move the shaft down to its lower limit before the replacement procedure following the removal steps.

12.2.1 U2 Belt (T6-B)

U2 belt Removal

- (1) Turn ON the Manipulator.
- (2) Press and hold the brake release switch to let the shaft down. Be sure to keep enough space and prevent the end effector hitting any peripheral equipment.

The brake release switch affects only Joint #3. When the brake release switch is pressed, the Joint #3 brake is released.

Be careful of the shaft falling while the brake release switch is being pressed because the shaft may be lowered by the weight of the end effector.

- (3) Turn OFF the Manipulator.
- (4) Remove the arm top cover.

Reference: 7.1 *Arm Top Cover*

- (5) Remove the user plate.

Reference: 7.7 *User Plate*

- (6) Remove the Joint # 2, 3, 4 AMP board unit.

Sems bolt: 2-M3×10

Remove the following connectors from AMP board unit.

- A: Power cable connector (×3)
- B: AMP cable connector (×3)
- C: Motor cable connector (×3)
- D: Brake cable connector (×1)

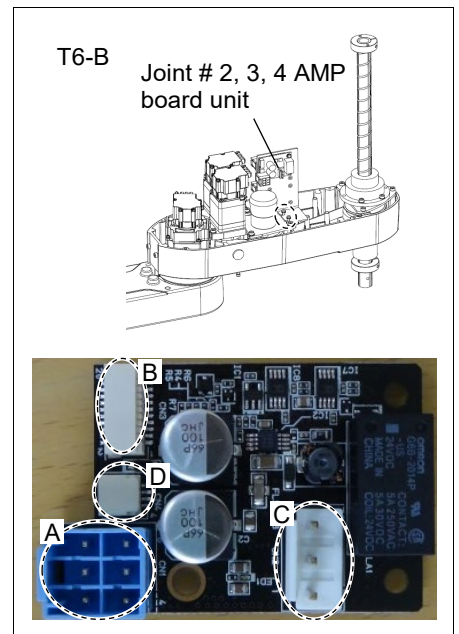

- (7) Loosen the Joint #3 motor unit mounting bolt.
3-M4×15+M4 washer

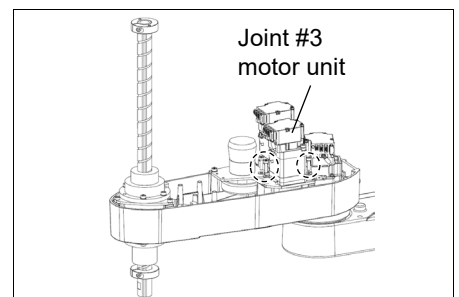

- (8) Loosen the Joint #4 motor unit mounting bolt.

3-M4x20+M4 washer

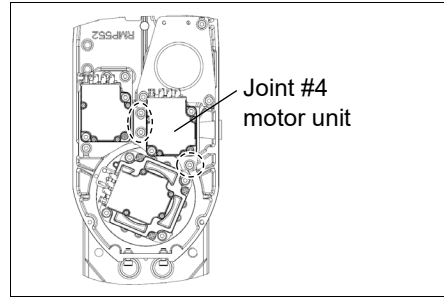

- (9) Unscrew the mounting screws of the joint #4 intermediate unit. Pull out the joint #4 intermediate unit and U1 belt upward.

3-M4x12+M4 washer

The washer will be necessary again when mounting intermediate unit. Be sure not to lose them.

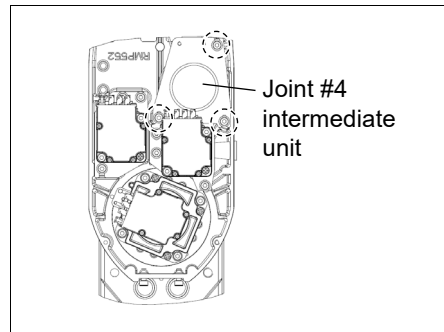

- (10) Remove the screws for the spline plate. Hold up the spline plate and pull out the Z belt and U2 belt.

3-M4x12

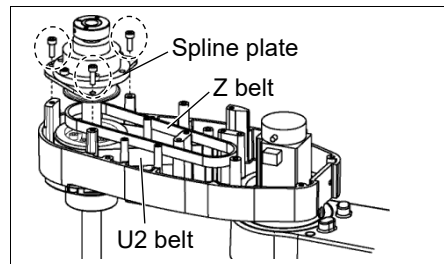

U2 belt Installation

- (1) Hold up the spline plate and set a new U2 belt around the U3 pulley.

Make sure the gear grooves of the belt are fit into those of the pulleys completely.

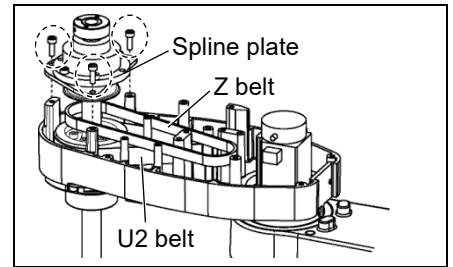

- (2) Hold up the spline plate and set the Z belt around the Z2 pulley.

Make sure the gear grooves of the belt are fit into those of the pulleys completely.

- (3) Secure temporarily the spline plate on the Arm #2 and move the shaft up and down several times before securing the spline plate.

3-M4x12

Tightening torque: $4 \pm 0.2 \text{ N}\cdot\text{m}$

- (4) While the U1 belt is set around the large pulley of Joint #4 intermediate unit, set the U2 belt inside the arm #2 around the small pulley and put on the upper surface of the arm #2.

Make sure the gear grooves of the belt are fit into those of the pulleys.

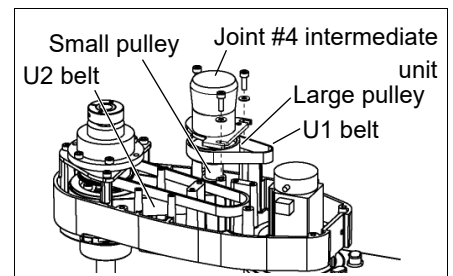

- (5) Secure temporarily the Joint #4 intermediate unit by screws.

3-M4x12+M4 washer

Check that the Joint #4 intermediate unit can be moved by hand, and it will not tilt when pulled. If the unit is secured too loose or too tight, the belt will not have the proper tension.

- (6) Apply the proper tension to U2 belt, and secure the Joint #4 intermediate unit.

Set a suitable cord or string around the part near the plate of the Joint #4 intermediate unit near its mounting plate. Then, pull the cord using a force gage or similar tool to apply the specified tension shown below.

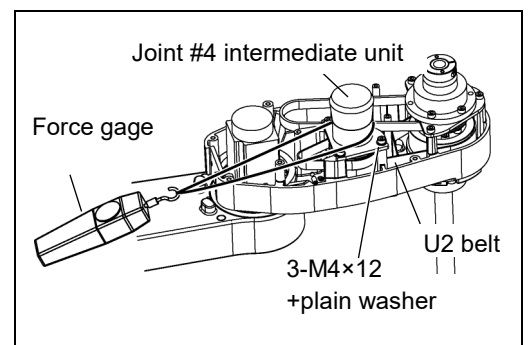

U2 belt tension:

51 N ($5.2 \pm 0.75 \text{ kgf}$)

Axial force (when pulling):

102.0 N ($10.4 \pm 0.75 \text{ kgf}$)

Apply the following torque to secure the plate.

Tightening torque: $4 \pm 0.2 \text{ N}\cdot\text{m}$

- (7) Apply the proper tension to U1 belt, and secure the Joint #4 motor unit.
Set a suitable cord or string around the part near the plate of the Joint #4 motor unit near its mounting plate. Then, pull the cord using a force gage or similar tool to apply the specified tension shown below.

U1 belt tension:

29.0 N (2.95 ± 0.5 kgf)

Axial force (when pulling):

58 N (5.9 ± 0.5 kgf)

Apply the following torque to secure the plate.

Tightening torque: 4 ± 0.2 N·m

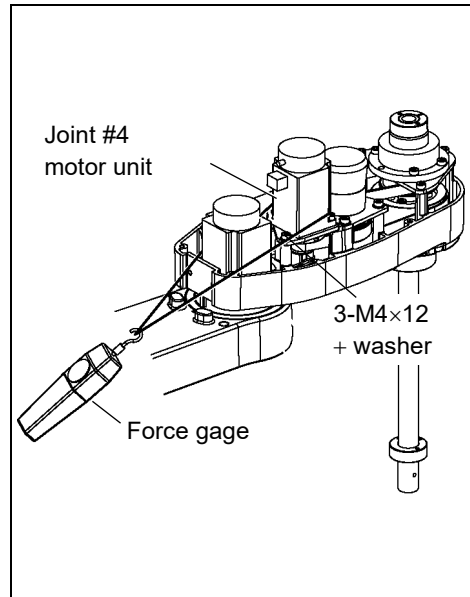

NOTE

To check belt tension with the tension meter, refer to “12.3 Checking the Timing Belt Tension”.

- (8) Apply the proper tension to the Z belt, and secure the Joint #3 motor unit.

Set a suitable cord or string around the part near the plate of the Joint #3 motor unit near its mounting plate. Then, pull the cord using a force gage or similar tool to apply the specified tension shown below.

Z belt tension:

34.5 N (3.5 ± 0.5 kgf)

Axial force (when pulling):

69.0 N (7.0 ± 0.5 kgf)

Apply the following torque to secure the plate.

Tightening torque: 4 ± 0.2 N·m

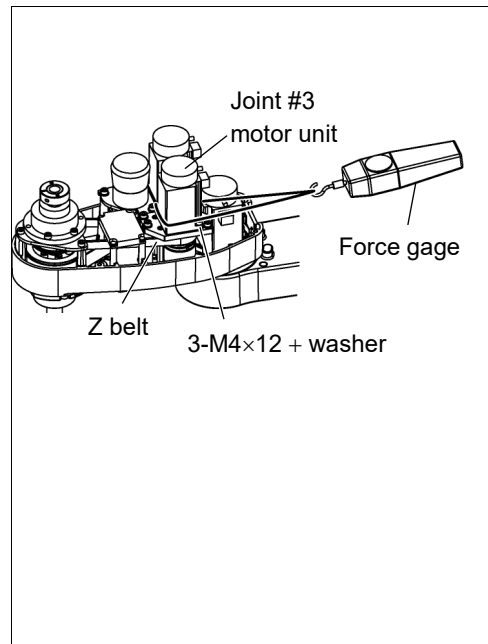

NOTE

To check belt tension with the tension meter, refer to the following.

11.4 Checking the Timing Belt Tension (Z Belt)

(9) Mount the Joint # 2, 3, 4 AMP board unit.

Sems bolt: 2-M3×10

Tightening torque: $0.9 \pm 0.05 \text{ N}\cdot\text{m}$

Connect the following connectors to the AMP board unit.

A: Power cable connector (×3)

B: AMP cable connector (×3)

C: Motor cable connector (×3)

D: Brake cable connector (×1)

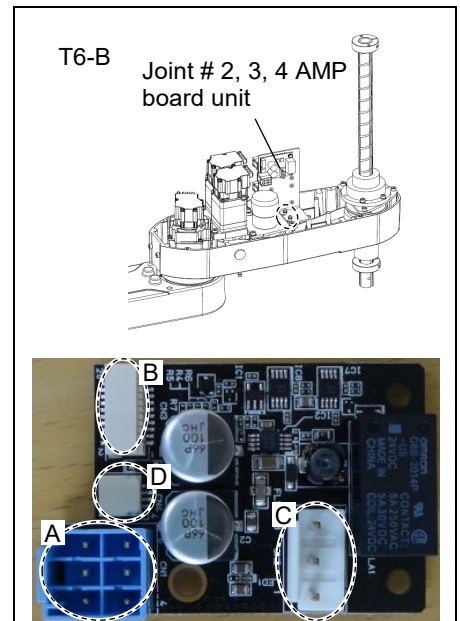

(10) Mount the user plate.

Reference: 7.7 *User Plate*

(11) Mount the arm top cover.

Reference: 7.1 *Arm Top Cover*

(12) Perform the calibration of Joints #3, #4.

Reference: 17. *Calibration*

12.2.2 U1 Belt (T6-B)

U1 belt Removal

- (1) Remove the Joint #4 motor unit.
Reference: *12.1 Replacing Joint #4 Motor “Joint #4 motor Removal”*
- (2) Remove the Joint #4 intermediate unit and then remove the U1 belt.
Reference: *12.2.1 U2 Belt “U2 belt Removal”*

U1 belt Installation

- (1) Apply the proper tension to U2 belt, and secure the Joint #4 intermediate unit.
Reference: *12.2.1 U2 Belt “U2 belt Installation”*
- (2) Apply the proper tension to U1 belt, and secure the Joint #4 motor unit.
Reference: *12.1 Replacing Joint #4 Motor “Joint #3 motor Installation”*
- (3) Perform the calibration for the Joint #4.
Reference: *17. Calibration*

12.2.3 U Belt (T3-B)

U belt
Removal

- (1) Remove the Joint #4 motor unit.

Reference: 12.1 Replacing Joint #4 Motor “Joint #4 motor Removal”

- (2) Loosen the Joint #3 motor unit mounting bolt.

a: 2-M4×15+M4 slotted hole washer

b: M3×12+M3 slotted hole washer

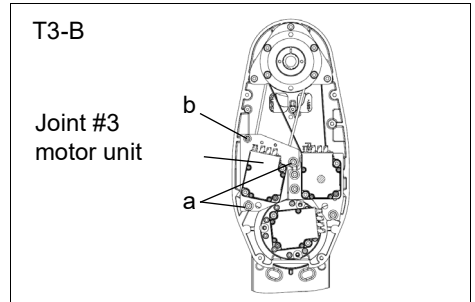

- (3) Unscrew the spline plate mounting screws.

3-M4×12

Holding the spline plate upward, pull out the Z Belt and U belt.

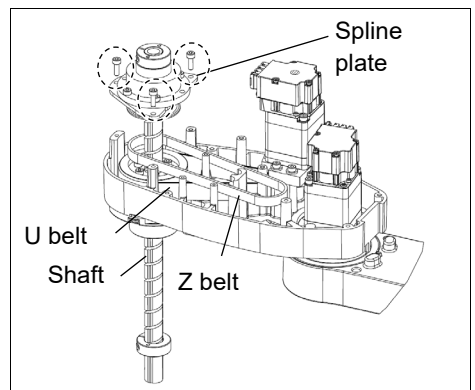
U belt
Installation

NOTE  For tightening hexagon socket head cap bolts, refer to “2.4 Tightening Hexagon Socket Head Cap Bolts”.

- (1) Hold up the spline plate and set a new U belt around the U2 pulley.

3-M4×12

Make sure the gear grooves of the belt are fit into those of the pulleys completely.

- (2) Hold up the spline plate and set the Z belt around the Z2 pulley.

Make sure the gear grooves of the belt are fit into those of the pulleys completely.

- (3) Secure temporarily the spline plate on the Arm #2 and move the shaft up and down several times before securing the spline plate.

- (4) Mount the Joint #4 motor unit.

Reference: 12.1 Replacing Joint #4 Motor “Joint #4 motor Installation”

- (5) Apply the proper tension to the Z belt, and secure the Joint #3 motor unit.

Reference: 11.1 Replacing Joint #3 Motor “Joint #3 motor Installation”

- (6) Perform the calibration of Joints #3, #4.

Reference: 17. Calibration

12.3 Checking the Timing Belt Tension

	Name	Quantity	Note
Tools	Sonic tension meter	1	For details of usage and measurement methods of the tension meter, refer to the instruction manual of the tension meter.

Joint #4 (1) Enter appropriate setting values to the sonic tension meter.

Belt tension check

Model	Belt	Unit weight M [g/ (1 mm width × 1 m length)]	Width W [mm]	Span S [mm]
T3-B	U belt	1.3	17	127
T6-B	U1 belt	2.0	10	54
	U2 belt	2.0	15	170

- (2) T3-B: Flip the U belt and measure the tension.
 T6-B: Flip the U2 belt and measure the tension.

NOTE  Measurement failure may occur if the microphone touches the belt during measurement.

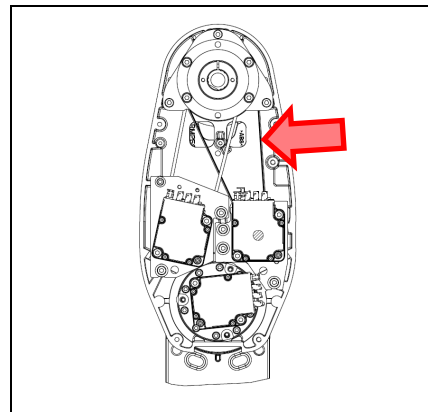

- (3) T6-B : Remove the rubber plug from the hole on the Arm #2.

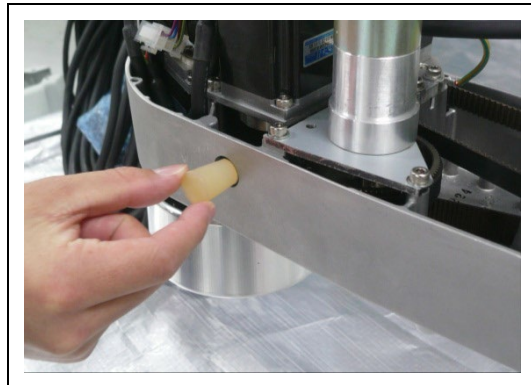

Flip the U1 belt and measure the tension.

NOTE  For T6-B, insert the microphone of the tension meter to the hole on the arm to measure tension.

Measurement failure may occur if the microphone touches the belt during measurement.

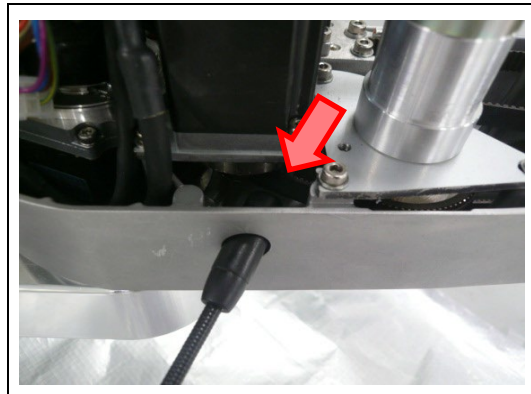

13. Ball Screw Spline Unit



WARNING

- Do not connect or disconnect the motor connectors while the power to the robot system is turned ON. Connecting or disconnecting the motor connectors with the power ON is extremely hazardous and may result in serious bodily injury as the Manipulator may move abnormally, and also may result in electric shock and/or malfunction of the robot system.
- To shut off power to the robot system, disconnect the power plug from the power source. Be sure to connect the AC power cable to a power receptacle. DO NOT connect it directly to a factory power source.
- Before performing any replacement procedure, turn OFF the Controller and related equipment, and then disconnect the power plug from the power source. Performing any replacement procedure with the power ON is extremely hazardous and may result in electric shock and/or malfunction of the robot system.

After parts have been replaced (motors, reduction gear units, a brake, timing belts, ball screw spline unit, etc.), the Manipulator cannot operate properly because a mismatch exists between the origin stored in each motor and its corresponding origin stored in the Robot system.

Because of that, it is necessary to perform calibration (encoder rest and calibration) to match these origins.

Refer to “17. Calibration” to execute the calibration.

	Name	Quantity	NOTE	
Maintenance part	Ball Screw Spline Unit	150st	1	T3-B: 1792117
		200st	1	T6-B: 1750572
Tools	Hexagonal wrench (width across flats: 3 mm)		1	For M4 screw
	Torque wrench		1	
	Cross-point screwdriver (No. 2)		1	For cross-recessed screw
	Force gage		1	Belt tension: Z, U: 69 N (7.0 ± 0.5 kgf) U1: 58 N (5.9 ± 0.5 kgf) U2: 102 N (10.4 ± 0.75 kgf)
	Suitable cord (Length about 800mm)		1	For belt tension
	Wiping cloth		1	For wiping grease (Spline shaft)
Material	Wire tie	-		
Grease	For Ball Screw Spline Unit (AFB grease)	Proper quantity		

NOTE



A brake is mounted on the Joint #3 motor to prevent the shaft from lowering down due to the weight of the end effector while the power to the Manipulator is OFF or while the motor is in OFF status (MOTOR OFF).

However, the brake does not work during replacement. Refer to removal steps (1) to (3) to move the shaft down to its lower limit before the replacement procedure.

Ball Screw
Spline Unit
Removal

- (1) Turn ON the Manipulator.
- (2) Press and hold the brake release switch to let the shaft down. Be sure to keep enough space and prevent the end effector hitting any peripheral equipment.

NOTE  The brake release switch affects only Joint #3. When the brake release switch is pressed, the Joint #3 brake is released.

Be careful of the shaft falling while the brake release switch is being pressed because the shaft may be lowered by the weight of the end effector.

- (3) Turn OFF the Manipulator.
- (4) Detach the wires/tubes from the end effector and remove the end effector.
- (5) Remove the arm top cover and arm bottom cover.

Reference: 7. Covers

- (6) Remove three screws mounting the spline plate.

a: 3-M4×12

- (7) Remove four screws mounting the spline nut.

b: T3-B: 4-M4×10
T6-B: 4-M4×12

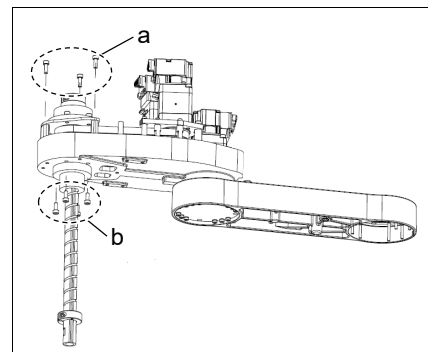

- (8) Pull out the following toward the Arm #2 upper side.

Ball screw spline unit Z belt U belt (T3-B) U2belt (T6-B)

Ball Screw
Spline Unit
Installation

NOTE For tightening hexagon socket head cap bolts, refer to “2.4 *Tightening Hexagon Socket Head Cap Bolts*”.

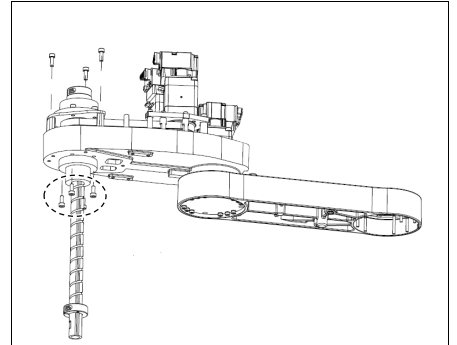

- (1) Insert a new ball screw spline unit in the Arm #2.
- (2) Secure the spline nut from the bottom side of the Arm #2.

T3-B: 4-M4×10
T6-B: 4-M4×12



- (3) Mount the following.
 - U belt (T3-B) U2 belt (T6-B) Z belt
 - Reference: 12.2 *Replacing the Timing Belt “Installation”*
- (4) Mount the Arm Top Cover and Arm Bottom Cover.
 - Reference: 7. *Covers*
- (5) Grease the shaft.
 - Reference: 2.3 *Greasing the Ball Screw Spline Unit*
- (6) Mount the end effector, cables, and tubes.
- (7) Perform the calibration of Joints #3, #4.
 - Reference: 17. *Calibration*

14. Lithium Battery, SD Card, and Boards

 WARNING	<ul style="list-style-type: none"> ■ Do not connect or disconnect the motor connectors while the power to the robot system is turned ON. Connecting or disconnecting the motor connectors with the power ON is extremely hazardous and may result in serious bodily injury as the Manipulator may move abnormally, and also may result in electric shock and/or malfunction of the robot system. ■ To shut off power to the robot system, disconnect the power plug from the power source. Be sure to connect the AC power cable to a power receptacle. DO NOT connect it directly to a factory power source. ■ Before performing any replacement procedure, turn OFF the robot system and related equipment, and then disconnect the power plug from the power source. Performing any replacement procedure with the power ON is extremely hazardous and may result in electric shock and/or malfunction of the robot system.
 WARNING	<ul style="list-style-type: none"> ■ Use meticulous care when handling the lithium battery. Improper handling of the lithium battery as mentioned below is extremely hazardous, may result in heat generation, leakage, explosion, or inflammation, and may cause serious safety problems. <ul style="list-style-type: none"> - Battery Charge - Deformation by Pressure - Disassembly - Short-circuit (Polarity; Positive/Negative) - Incorrect Installation - Heating (85 °C or more) - Exposing to Fire - Soldering the terminal of the lithium battery directly - Forced Discharge ■ When disposing of the battery, consult with the professional disposal services or comply with the local regulation. Spent battery or not, make sure the battery terminal is insulated. If the terminal contacts with the other metals, it may short and result in heat generation, leakage, explosion, or inflammation.

The life span of the lithium battery varies depending on the energizing hours and installation environment of the Manipulator. It is about 7 years as a rough guide. (when the Manipulator is connected to power for 8 hours a day)

When the Manipulator is not connected to power, the battery consumption will significantly increase compared to when the Manipulator is energized.

If warnings of voltage reduction occur, replace the lithium battery even if it has not reached the above product life.



For the EPSON RC+ 7.0, the recommended replacement time for the battery can be checked in the [Maintenance] dialog box of the EPSON RC+ 7.0.

Reference: *12.2 Replacing the Timing Belt “Installation” “4. Alarm”*

The battery may run out if it passes the recommended replacement time.

If no warnings of voltage reduction occur, the calibration for all joints is not necessary. You need to perform calibration if the position moves from the originals after replaced the battery.

Always use the lithium battery and battery board designated by us.

Reference: *“19. Maintenance Parts List.”*

Be careful of the battery polarity to connect it correctly.

14.1 Replacing the CPU/DPB Boards

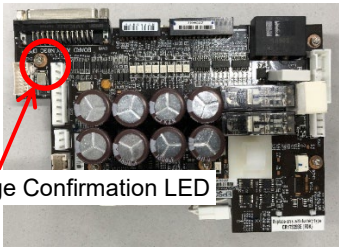
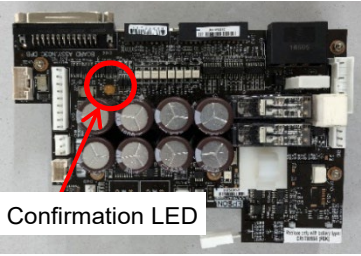
 WARNING	<p>■ Make sure that orange colored charge confirmation LED on the DPB turns off when eject the CPU or DPB. If operating without tuning off the LED, electric shock or other serious problems for safety may occur.</p>
	<div style="display: flex; justify-content: space-around;"> <div style="text-align: center;"> <p>T3-B</p>  <p>Charge Confirmation LED</p> </div> <div style="text-align: center;"> <p>T6-B</p>  <p>Charge Confirmation LED</p> </div> </div>

	Name	Quantity	NOTE
Maintenance part	CPU/DPB boards	1	T3-B: 2182747 T6-B: 2191143
Tools	Hexagonal wrench Width across flats: 2 mm	1	For M3 button bolt
	Cross-point screwdriver	1	

CPU/DPB boards (1) Turn OFF the Manipulator.

Replacement

(2) Remove the connector plate.

Reference: “7.4 Connector Plate”

(3) Remove the following parts that connected to the Connector Plate.

Air tube

TP connector

(4) Unscrew CPU/DPB board mounting screws.

Hexagon socket head cap button bolt: 5-M3x5

Remove CPU/DPB board from a base.

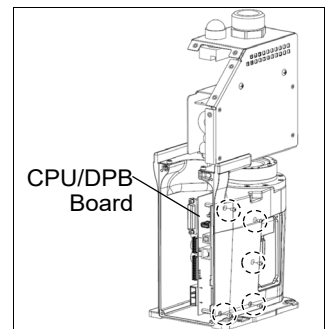

T6-B: Disconnect the connector of regenerative resistor junction cable. Then, remove the regenerative resistor fixing plate.

2-M4x8 Sems

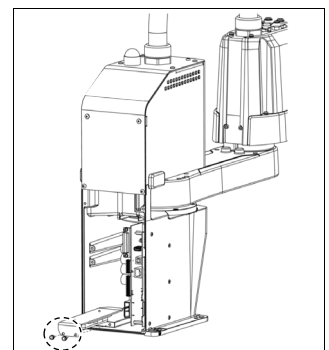

- (5) Remove the CPU/DPB board connector.

A: Power connector (IN/OUT ×1 for each)

B: Power cable connector (×1)

C: Signal cable connector

D: Hand I/O connector

E: LED connector

F: Regenerative resistor 1 (T6-B only)

G: Regenerative resistor 2 (T6-B only)

H: Battery connector

NOTE



Remember the cable layout for reconnecting the cables correctly after replacement.

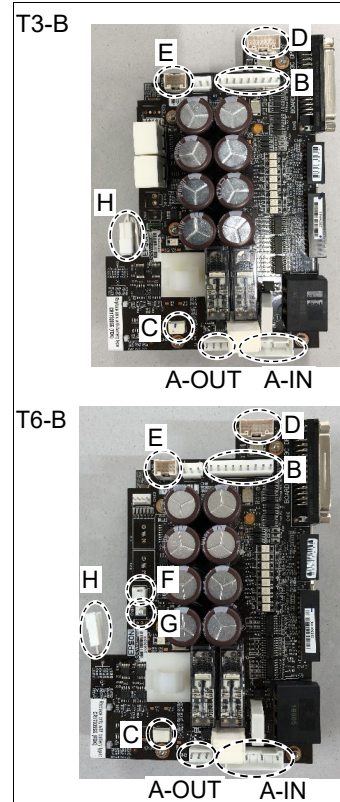

- (6) Remove the radiation sheet attached on the CPU board.

NOTE



Radiation sheet will be used again. Be sure to keep the sheet.

Be careful not to break the radiation sheet.

- (7) Attach the radiation sheet on the face of new CPU/DPB board connectors do not come out.

Be careful not to attach the sheet on the wrong face.

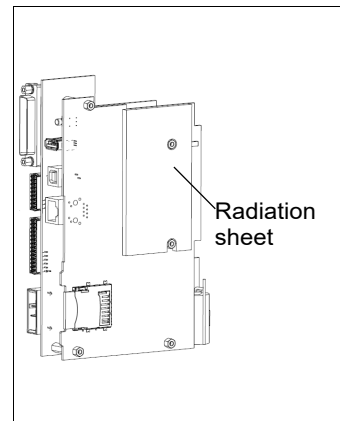

(8) Connect CPU/DPB board connector.

- A: Power connector (IN/OUT ×1 for each)
- B: Power cable connector (×1)
- C: Signal cable connector
- D: Hand I/O connector
- E: LED connector
- F: Regenerative resistor 1 (T6-B only)
- G: Regenerative resistor 2 (T6-B only)
- H: Battery connector

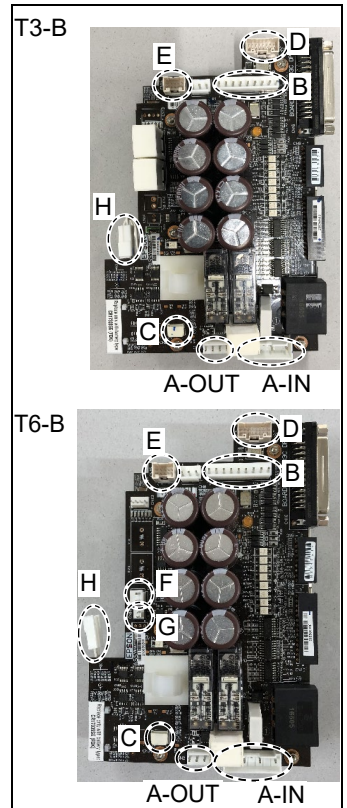

(9) Mount CPU/DPB board to base.

Hexagon socket head cap button bolt: 5-M3x5

Tightening torque: 0.45 ± 0.1 N·m

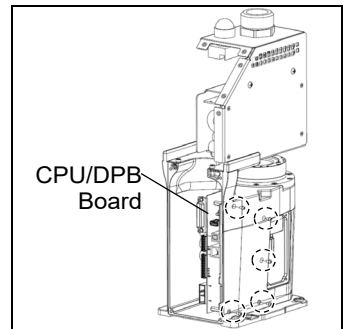

(10) T6-B: Mount the regenerative resistor fixing plate and connect the connector of regenerative resistor junction cable.

2-M4×8 Sems

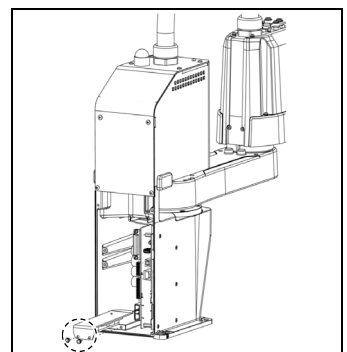

(11) Connect the following parts to the inside of the connector plate.

- Air tube
- TP connector

(12) Mount the connector plate.

Reference: “7.4 Connector Plate”

14.2 Replacing the Lithium Battery

	Name		Quantity	NOTE
Maintenance part	Lithium Battery		1	2113554
Tools	Hexagonal wrench	width across flats: 2 mm	1	For M3 button bolt
	Cross-point screwdriver		1	

NOTE Replace the battery within 30 minutes after turning OFF.



If more than 30 minutes pass after removing the battery, voltage of the capacitor lower and time may be reset.

Battery unit
(lithium battery)
Replacement

- (1) Remove CPU/DPB board from a base.
Reference: “14.1 Replacing the CPU/DPB Boards”

- (2) Remove the battery connector and connect the new one.

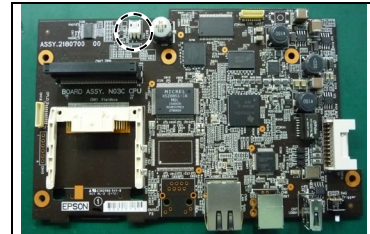

- (3) Mount CPU/DPB board to base.
Reference: “14.1 Replacing the CPU/DPB Boards”

14.3 Replacing the SD Card

	Name	Quantity	NOTE
Maintenance part	SD card	1	2182748
Tools	Cross-point screwdriver (No.2)	1	

NOTE



Remove the SD card after removing the fieldbus I/O module if fieldbus I/O module is inserted to the option slot. Also, install fieldbus I/O module after installing the SD card. Also, install fieldbus I/O module after installing the SD card.

For more details about fieldbus I/O module, refer to the following.

Reference: *T-B series Manual T3-B T6-B Manipulator*

17. Fieldbus I/O

NOTE



The SD card insertion direction differs depending on the product shipment time.

SD Card Removal

- (1) Turn OFF the Manipulator.
- (2) Remove the power plug.
- (3) Remove the optional slot cover on the back face of the Manipulator.

Sems bolt: 2-M3×6

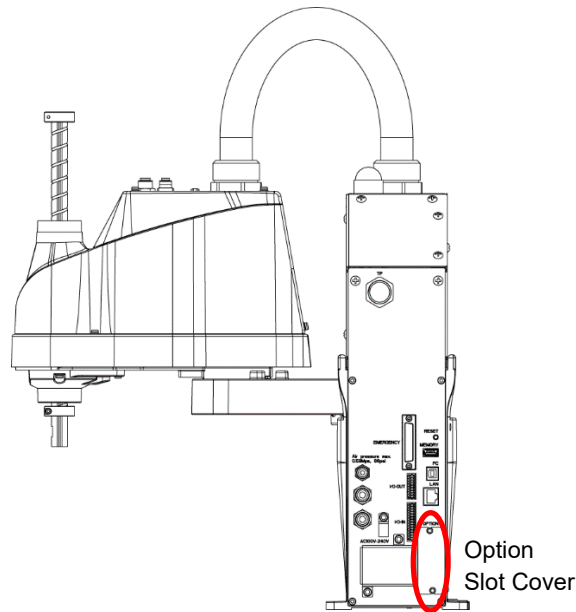

(Illustration: T3-B 401S)

- (4) Push the SD card which is inserted near the option slot to eject.

SD Card Installation



NOTE For tightening hexagon socket head cap bolts, refer to “2.4 Tightening Hexagon Socket Head Cap Bolts”.

- (1) Insert the SD card and inset to the SD card slot near the optional slot.
- (2) Mount the optional slot cover by screws.

Sems bolt: 2-M3×6

14.4 Replacing the Power Board

	Name	Quantity	NOTE
Maintenance part	Power Board	1	T3-B: 2182749
		2	T6-B: 2188638
Tools	Cross-point screwdriver (No. 2)	1	For cross-recessed screw
	Spanner (width across flats: 5.5mm)	1	For hexagonal posts

Power Board Replacement **NOTE**  For tightening hexagon socket head cap bolts, refer to “2.4 Tightening Hexagon Socket Head Cap Bolts”.

- (1) Turn OFF the Manipulator.
- (2) Remove the power unit cover.

Reference: “7.5 Power Unit Cover”

- (3) Remove the Power Board Cover.

T3-B: Truss screw: 2-M4×6

T6-B: Hexagon socket head cap bolts : 5-M3×6
Binding head small screws : M4×10

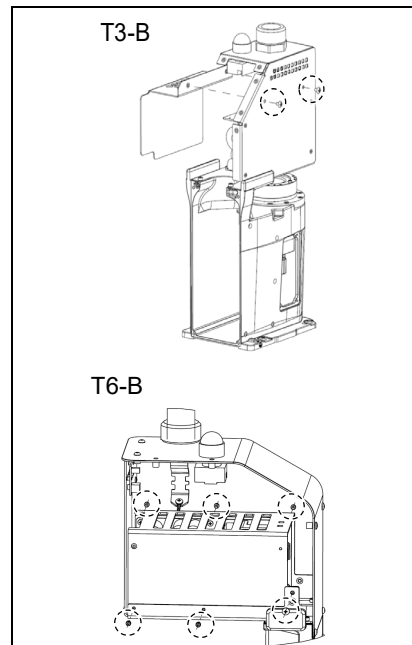

- (4) Remove the connectors of the Power board.

Power connector (IN/OUT ×1 for each)

NOTE 

For T6-B only:

There are two Power Board.

First, remove the connector of Power Board on the cover side.

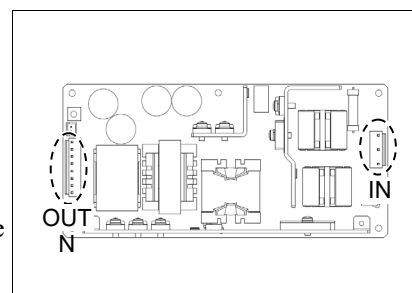

- (5) T3-B : Remove the Power Board.

Binding head small screws : 4-M3×10

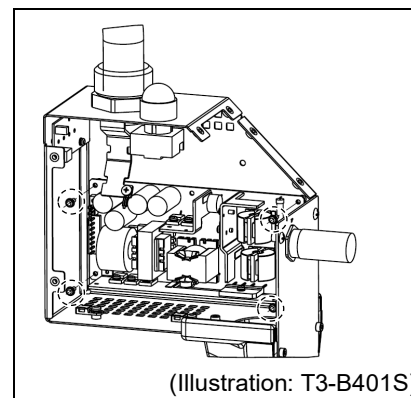

First, remove the connector of Power Board on the cover side.

Binding head small screws : 5-M3×10

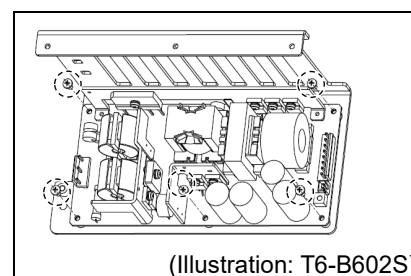

Remove the connectors of the base sheet metal side and then remove the Power Board.

Binding head small screws : 5-M3×10

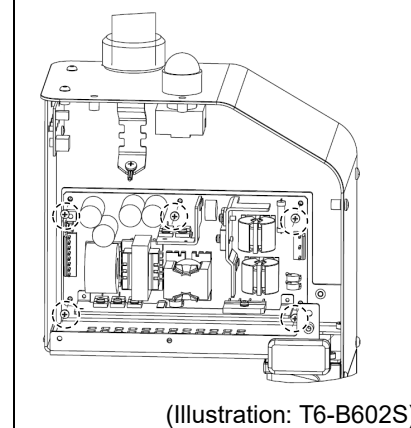

- (6) Mount new Power Board.

T3-B: Binding head small screws : 4-M3×10

T6-B: Binding head small screws : 10-M3×10

- (7) Connect the Power Board Connector.

Power connector (IN/OUT ×1 for each)

- (8) Mount the Power Board Cover.

T3-B: Truss screw: 2-M4×6

T6-B: Hexagon socket head cap button bolt: 5-M3×6

Binding head small screws: M4×10

- (9) Mount the Power unit cover.

Reference: “7.5 Power Unit Cover”

14.5 Fieldbus I/O

Fieldbus I/O supports the following models for T-B series.

DeviceNet™	CC-Link
PROFIBUS-DP	PROFINET
EtherNet/IP™	EtherCAT®
Modbus	

For details, refer to the following manual.

“Robot Controller Option Fieldbus I/O”

“EPSON RC+ 7.0 User’s Guide 11.7 Fieldbus Slave I/O”

	Name	Quantity	NOTE
Tools	Cross-point screwdriver (No. 2)	1	
	Torque wrench (T8)	1	Fieldbus I/O module supplied

Fieldbus I/O Module Installation

- (1) Turn OFF the Manipulator.
- (2) Remove the optional slot cover on the back face of the Manipulator.
Sems bolt: 2-M3×6

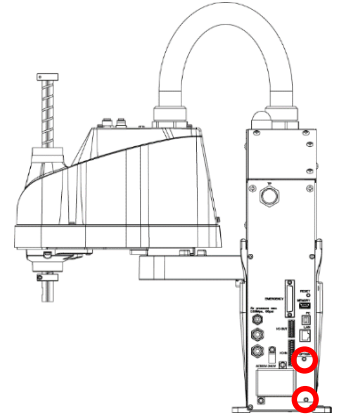

(Illustration: T3-B401S)

- (3) Inset the fieldbus I/O module to the option slot.

 CAUTION	<p>■ Check the clips of the fieldbus I/O module are securely hooked on the board when installing fieldbus I/O module. If clips do not be hooked securely, connector or fieldbus I/O module may get damages.</p>
--------------------	---

- (4) Tighten screws by using special tool until fieldbus I/O module is fixed completely.



Image of installation



Front



Back

Fieldbus I/O Module Removal

- (1) Unscrew the screws by using special tool until fieldbus I/O module is loosened.
- (2) Remove the fieldbus I/O module.
You can remove the module by pulling loosened screws toward.
- (3) Mount the option slot cover.

15. LED Lamp Unit



WARNING

- Do not connect or disconnect the connectors while the power to the robot system is turned ON. Connecting or disconnecting the motor connectors with the power ON is extremely hazardous and may result in serious bodily injury as the Manipulator may move abnormally, and also may result in electric shock and/or malfunction of the robot system.
- To shut off power to the robot system, disconnect the power plug from the power source. Be sure to connect the AC power cable to a power receptacle. DO NOT connect it directly to a factory power source.
- Before performing any replacement procedure, turn OFF the Controller and related equipment, and then disconnect the power plug from the power source. Performing any replacement procedure with the power ON is extremely hazardous and may result in electric shock and/or malfunction of the robot system.

	Name	Quantity	NOTE
Maintenance part	LED Lamp Unit	1	2182673
Tools	Cross-point screwdriver (No. 2)	1	For cross-recessed screw
	Nippers	1	
Material	Wire tie	1	

- LED Lamp Unit Replacement
- (1) Turn OFF the Manipulator.
 - (2) Remove the power unit cover.
Reference: “7.5 Power Unit Cover”

- (3) Remove the connector of LED board.

A: LED - LED board connector

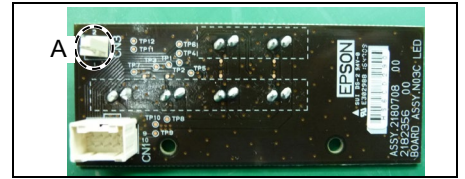

- (4) Disconnect the X1 and X2 terminals from the LED.

- (5) Turn the lens counterclockwise to remove.

Then, turn the lens holder counterclockwise to remove.

- (6) Remove the LED and ring from the Power Unit.

- (7) Connect the X1 and X2 terminals to the new LED.

Each terminal must be connected to the same terminal number on the LED.

- (8) Put the user plate between the ring and lens holder, and then secure the LED to the cover.

- (9) Mount the lens.

- (10) Connect the LED board connector.

LED - LED board connector

- (11) Remove the power unit cover.

Reference: “7.5 Power Unit Cover”

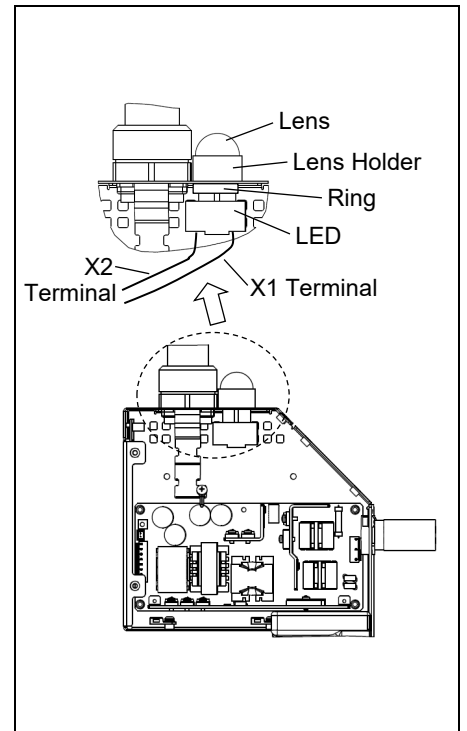

16. RESET Switch

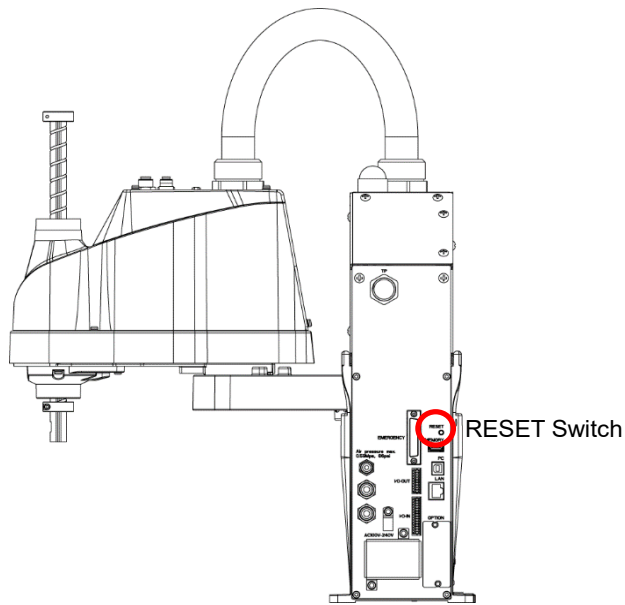

(Illustration: T3-B401S)

RESET switch has following function.

Manipulator reboot

Push the RESET switch for three seconds when booting the manipulator.
Manipulator reboots.

Shape of RESET switch is difficult to push. Push with sharp edged object as shown in the figure below when pushing the RESET switch.

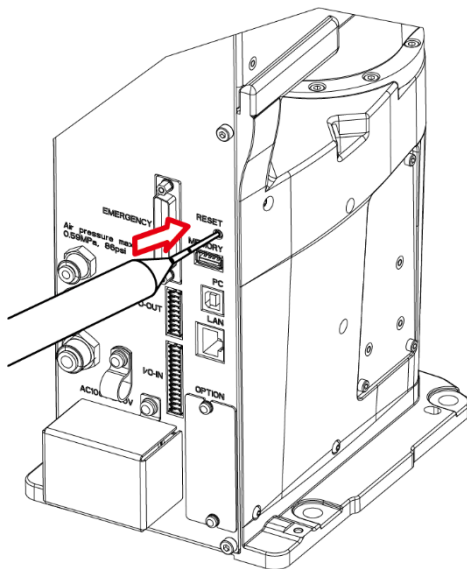

17. Calibration

17.1 About Calibration

After parts have been replaced (motors, reduction gear units, a brake, timing belts, ball screw spline unit, etc.), the Manipulator cannot operate properly because a mismatch exists between the origin stored in each motor and its corresponding origin stored in the Robot system.

Because of that, it is necessary to perform calibration (encoder rest and calibration) to match these origins. Note that calibration is not the same as teaching*.

*“Teaching” means to teach the Manipulator coordinate points (including poses) anywhere in the operating area of the Manipulator.

 WARNING	<ul style="list-style-type: none"> ■ To ensure safety, a safeguard must be installed for the robot system. For details of the safeguard, refer to “<i>T-B series Manual 1.5 Safeguard</i>”. ■ Before operating the robot system, make sure that no one is inside the safeguarded area. The robot system can be operated in the mode for teaching even when someone is inside the safeguarded area. The motion of the Manipulator is always in restricted (low speeds and low power) status to secure the safety of an operator. However, operating the robot system while someone is inside the safeguarded area is extremely hazardous and may result in serious safety problems in case that the Manipulator moves unexpectedly.
---	--

Command Input

Calibration procedures include the process to input commands. Select EPSON RC+ menu-[Tools]-[Command Window] to use the command window.

The information above is omitted in the calibration procedure.

Jog Motion

The process to set the jog motion is included in the [Jog & Teach] page of the Robot Manager. Select EPSON RC+ menu-[Tools]-[Robot Manager] and select the [Jog & Teach] tab to use the [Jog & Teach] page.

The page above is indicated as [Jog & Teach] in the calibration procedure.

17.2 Calibration Procedure

EPSON RC+ has a wizard for calibration.

This section indicates the calibration using the calibration wizard of EPSON RC+.

The way of calibration for each joint is the same except for some parts.

The follow the steps below are calibration using Joint #1. Follow the steps below to calibrate other joints.

When coordinates for the Manipulator working point require calculation, it is important for Joint #2 to be calibrated accurately. Execute the procedure in “Calibration Using Right / Left Arm Orientations” to accurately calibrate Joint #2. For details, refer to “17.3 Accurate Calibration of Joint #2”.

You cannot calibrate Joint #4 alone because of the structure of the Manipulator. When calibrating Joint #4, you must calibrate Joint #3 and #4 at the same time.

NOTE If Err9716 or 5016 (Power supply failure of the absolute encoder. Replace the battery. Check the robot internal wiring) occurs, apply the procedure of “17.4 Reference: Calibration Procedure Without Using Calibration Wizard - 3. Encoder Initialization” and then, start the calibration wizard.

The reference point (a point to check the accuracy) needs to be specified for calibration.

- (1) Start the calibration wizard.
 - i. Select EPSON RC+ 7.0 menu-[Setup]-[System Configuration] to display the [System Configuration] dialog.
 - ii. Select [Robot]-[Robot**]-[Calibration] to display [Robot**: Calibration].
 - iii. Select the joint and click the <Calibrate...> button.

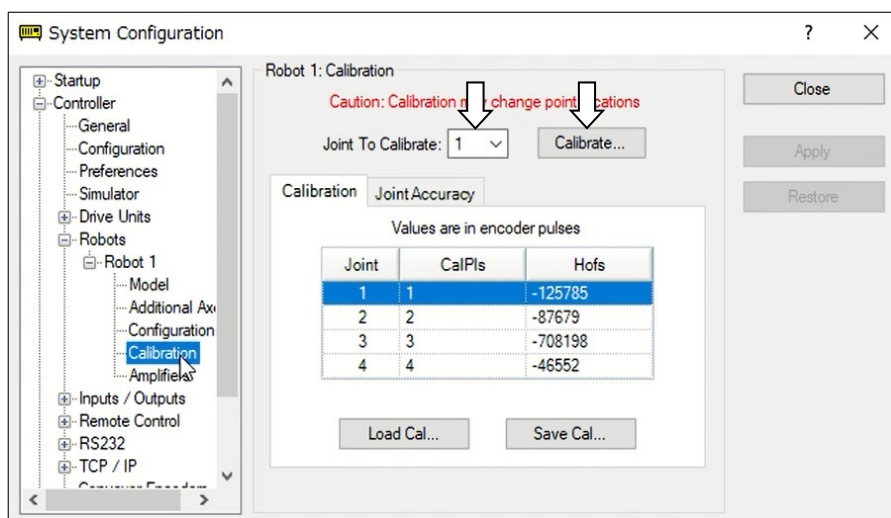

- (2) Confirm the warning message and click the <Yes> button.

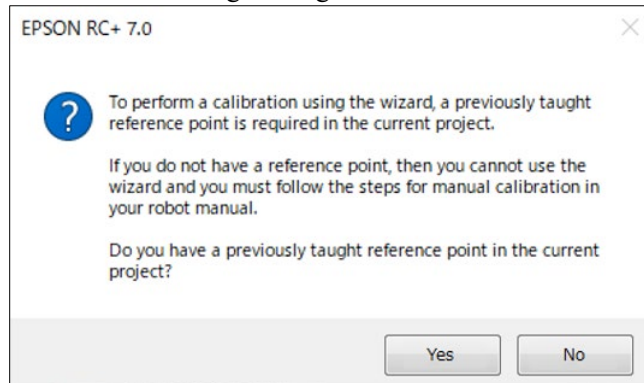

- (3) Move the joint to calibrate manually to approximate zero position, as shown in the dialog. After moving the joint, click the <Next> button.

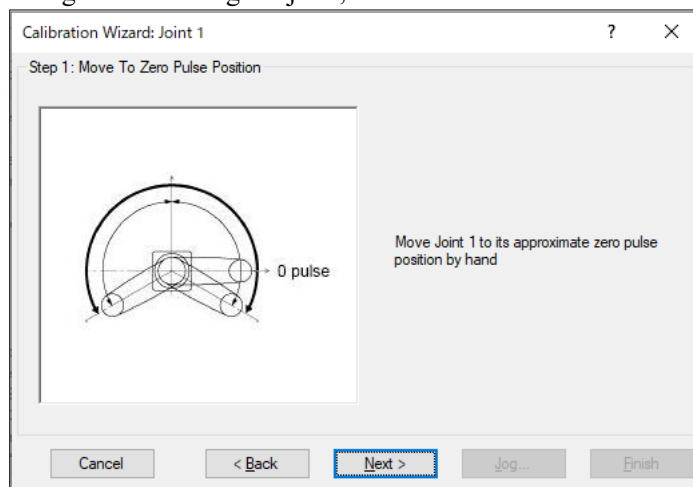

0 pulse position of Joint #1:
Position aligned with X-axis in
Robot coordinate system

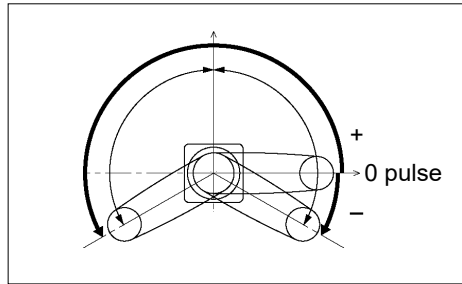

0 pulse position of Joint #2:
Position where Arms #1 and #2
are in a straight line
(Regardless of the Joint #1
direction.)

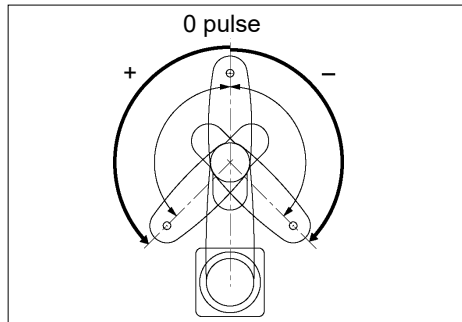

0 pulse position of Joint #3:
Upper limit position in motion
range

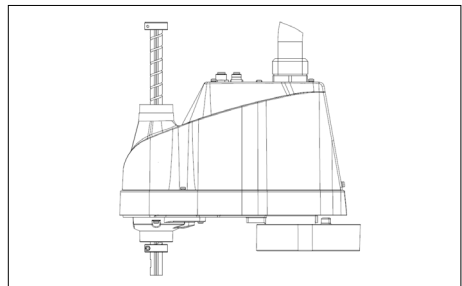

The height of Joint #3 depends
on manipulator.

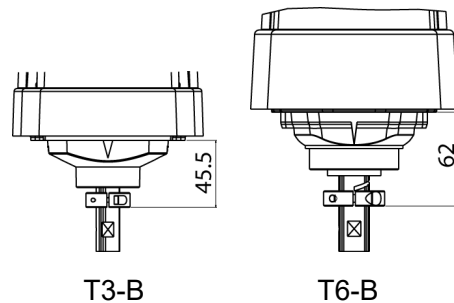

0 pulse position of Joint #4:
Position where the flat surface
(or groove in the up/down
mechanical stop) on the shaft
faces toward the tip of Arm #2

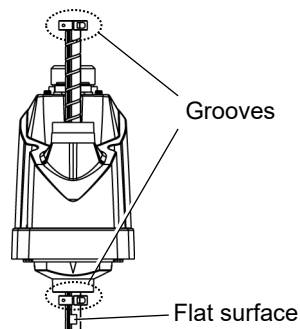
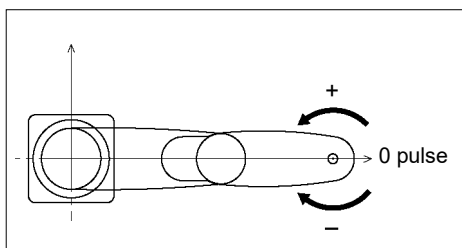

- (4) Reset the encoder. Click the <Yes> button.

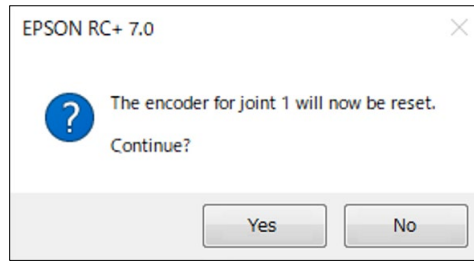

- (5) Controller (Manipulator) restarts.

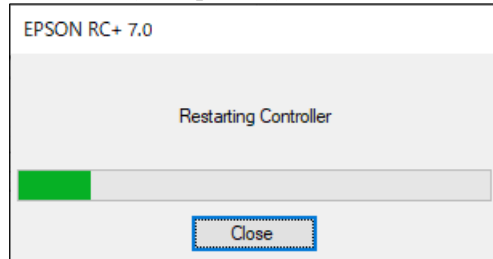

* This window will disappear when the Controller starts up.

- (6) Select the reference point to use for calibration, and click the <Next> button.

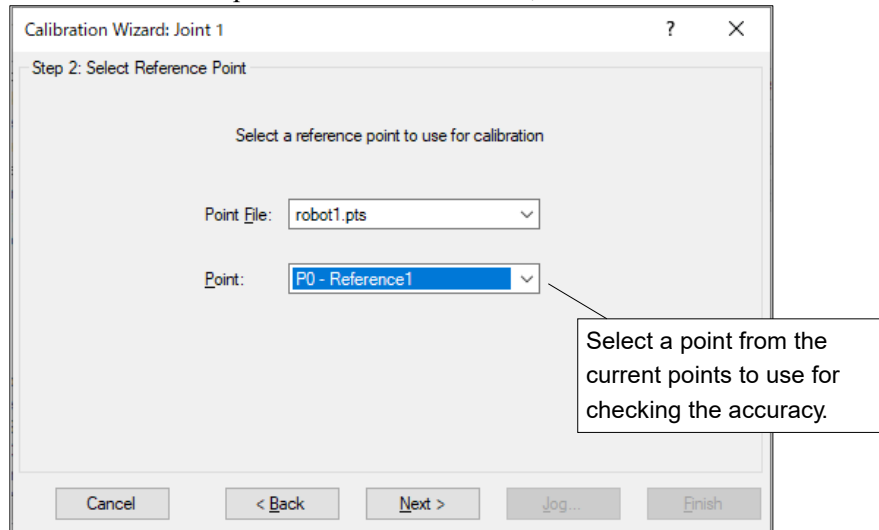

- (7) Click the <Jog...> button to display the [Jog & Teach] dialog.

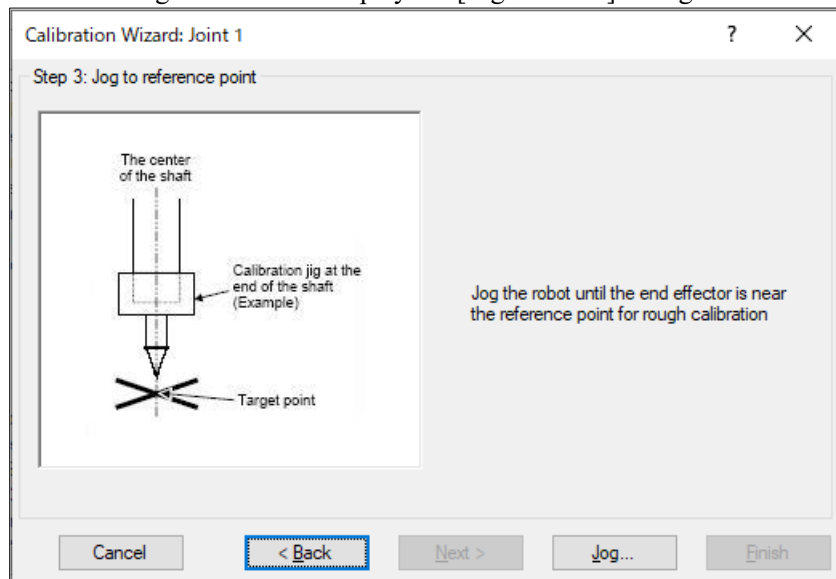

- (8) Jog the end effector to approximate reference point in the [Jog & Teach] dialog for rough calibration. Then click the <OK> button.

Before operating the robot, open the [Control Panel] and click on the <Motor ON> button.

NOTE  Move the end effector from the zero pulse position to the approximate reference point where rough calibration will be executed at by the jog motion. Position gap may occur if the end effector is not moved by the jog motion.

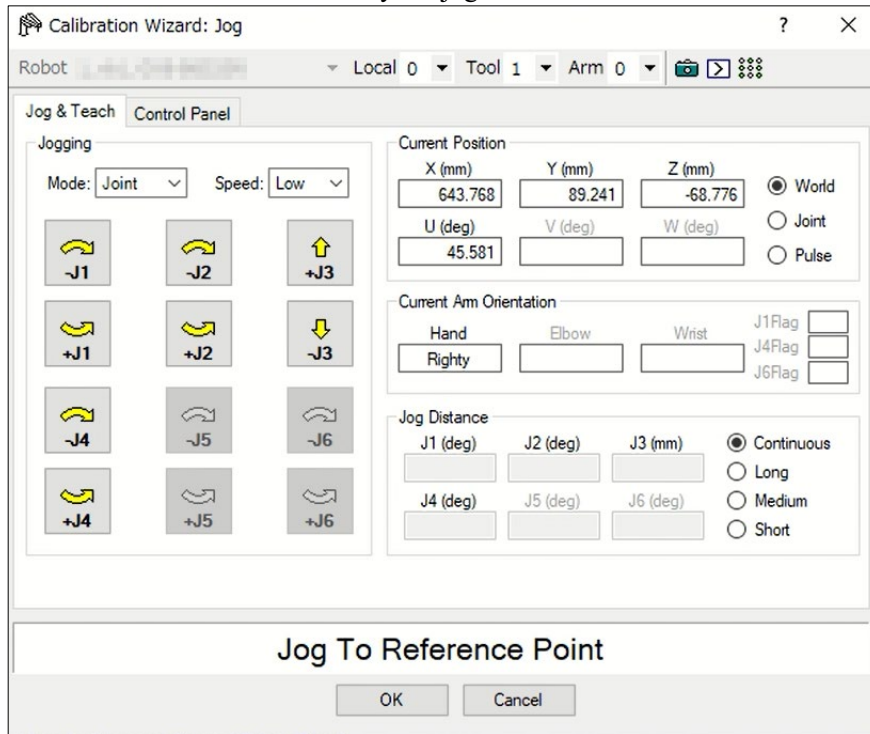

- (9) Click the <Next> button.

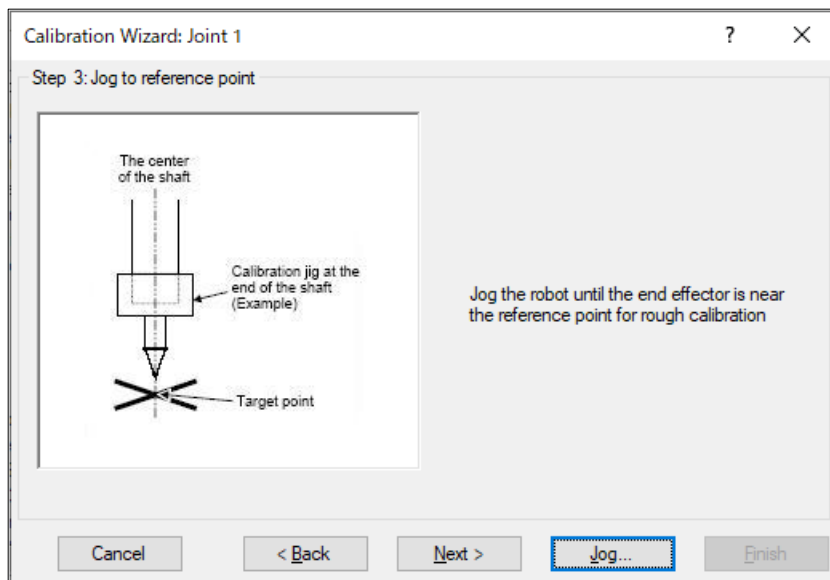

(10) The manipulator moves to the reference point. Click the <Execute> button.

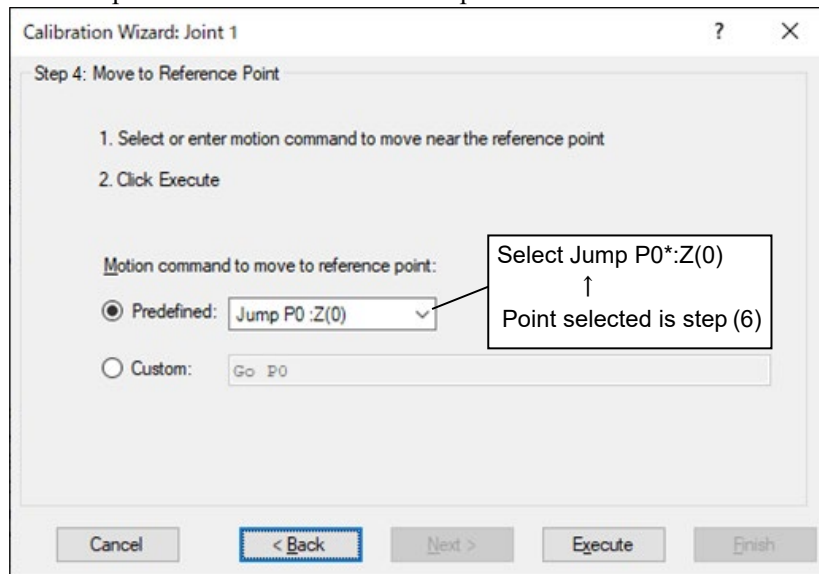

(11) Confirm the message and click the <Yes> button.

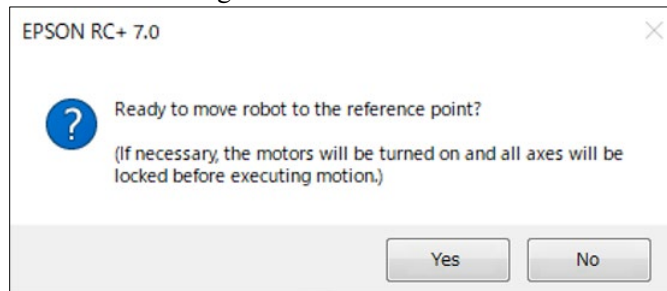

(12) After the manipulator moves to the reference point, click the <Next> button.

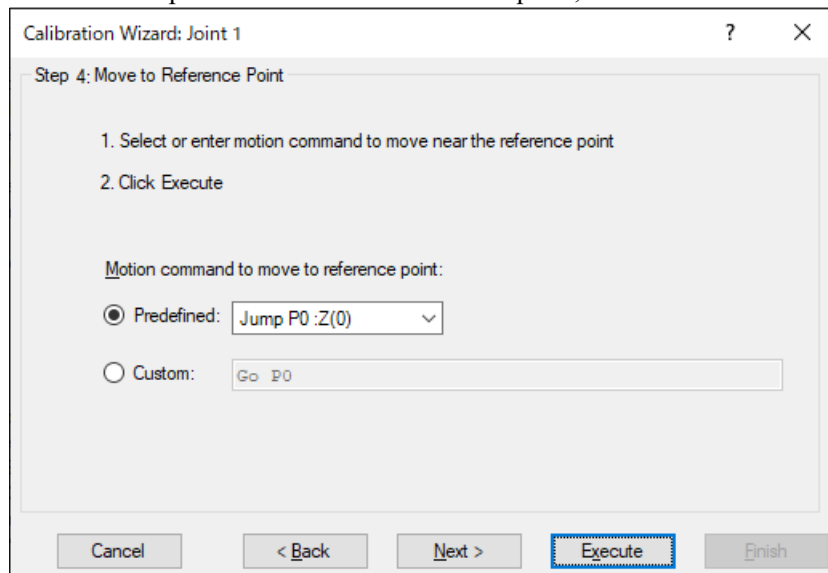

(13) Jog to the accurate reference position. Click the <Jog> button.

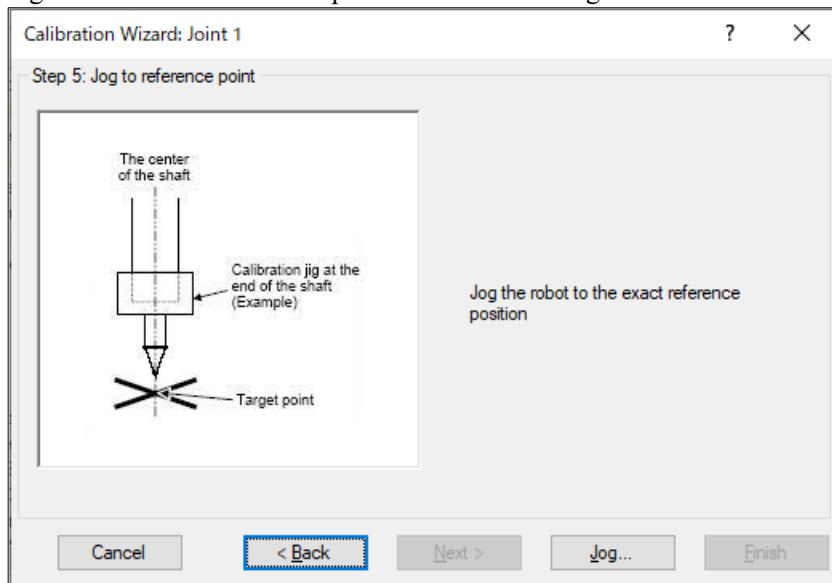

(14) Jog the end effector to accurate reference point and click the <OK> button.

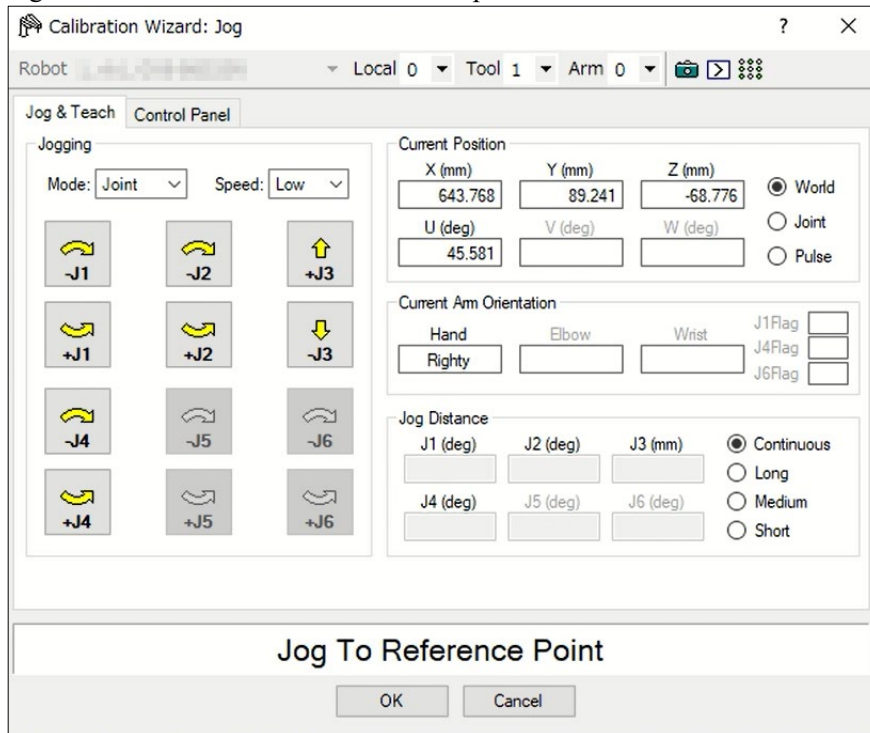

* For only Position Joint #2, move Joint #3 to around 0 pulse after Jogged to the accurate reference point.

(15) Click the <Next> button.

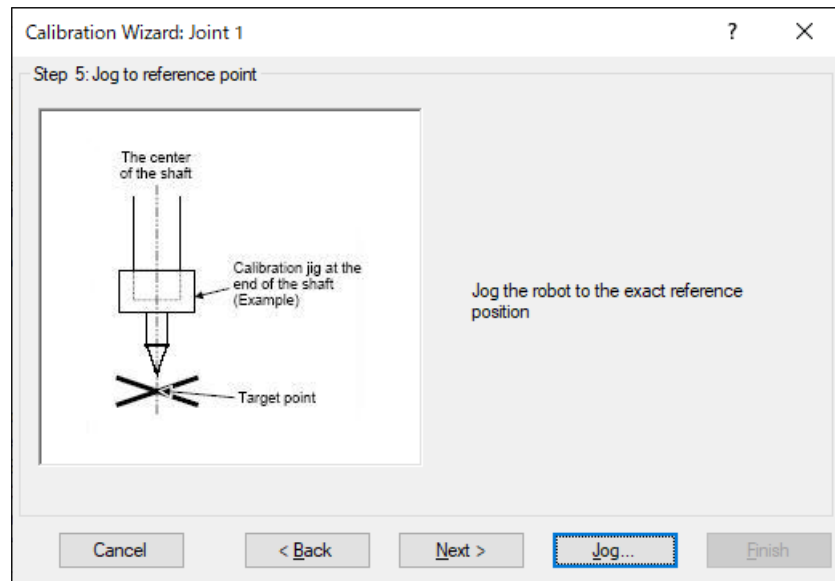

(16) Execute the procedure in “Calibration Using Right / Left Arm Orientations” to accurately calibrate Joint #2.

Go on to the step (17) for the other joint’s calibration.

- i. Move to another point that has different pose (from righty to lefty) using Jump command. Click the <Yes> button.

Click the <Yes> button.

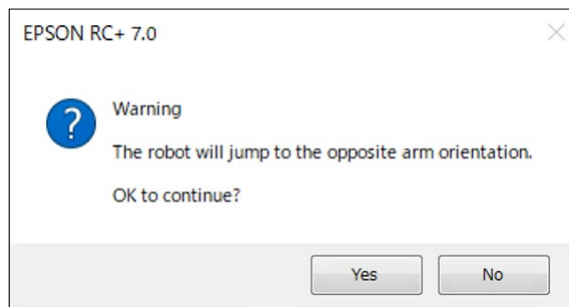

- ii. Jog to the accurate reference position.

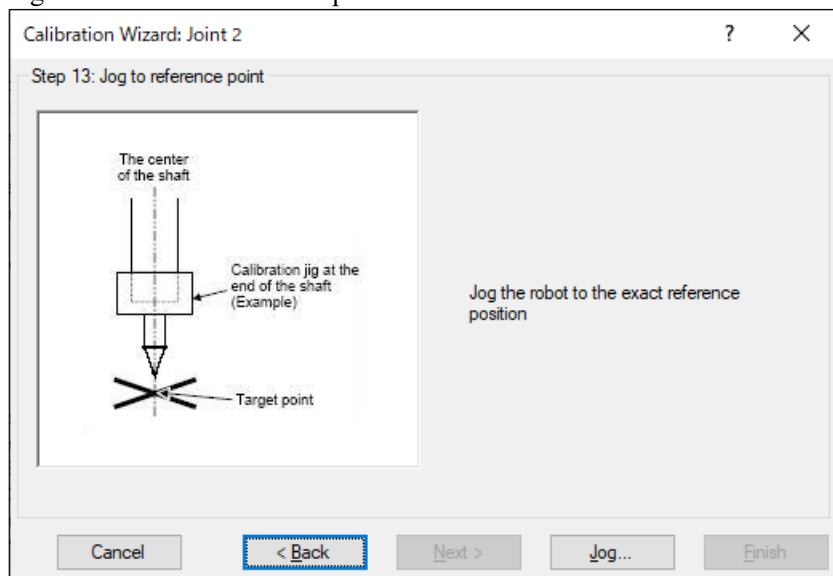

- iii. Jog to the accurate reference position and adjust the position. Click the <OK> button.

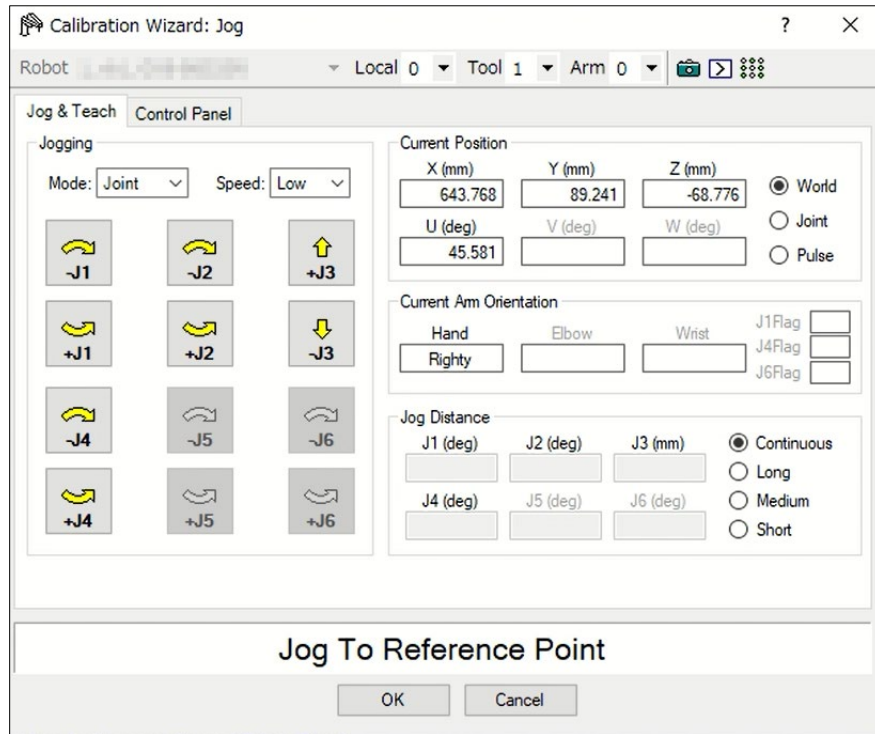

- iv. Click the <Next> button.

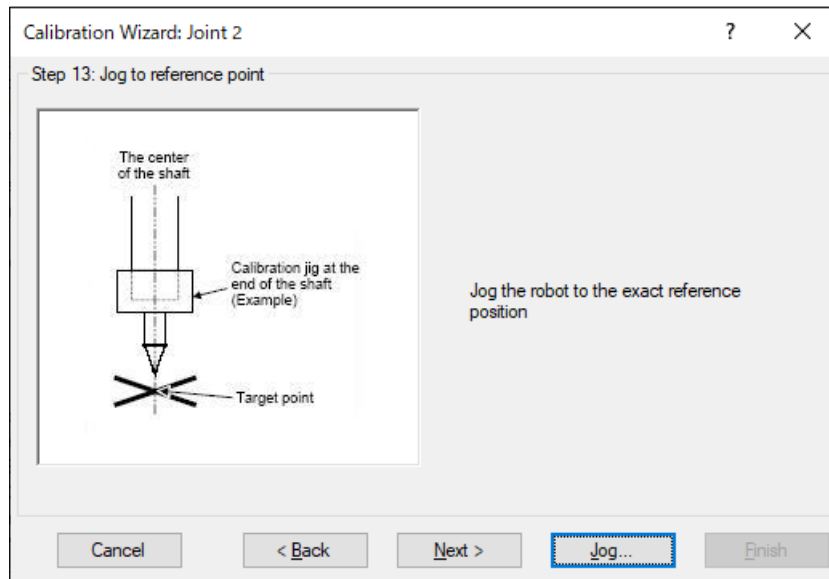

(17) Calibration is complete. Click the <Finish> button.

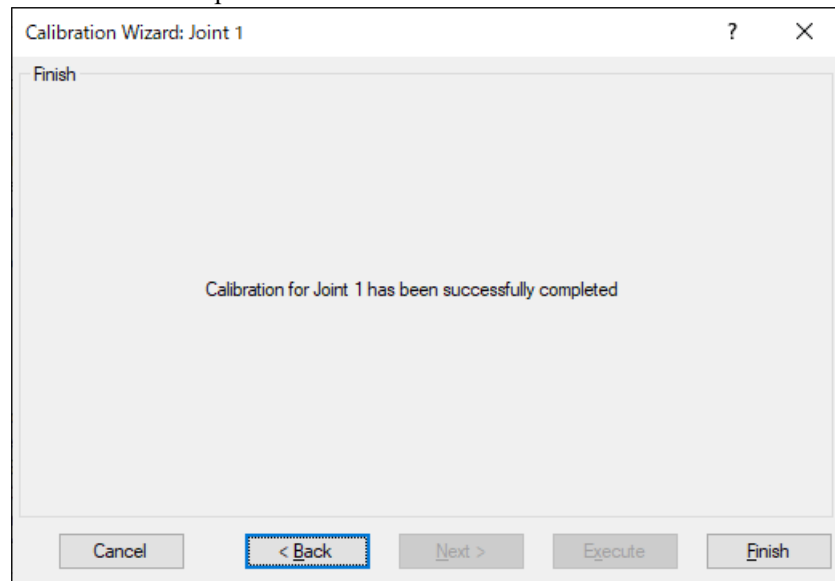

(18) Move the manipulator to other points and check if it can move without problems.
Teach points where appropriate.

17.3 Accurate Calibration of Joint #2

When coordinates for the Manipulator working point require calculation, it is important for Joint #2 to be calibrated accurately.

NOTE  If the accuracy of Joint #2 is not obtained through the steps in the section “17.2 Calibration Procedure”, follow the steps below “Calibration Using Right / Left Arm Orientations” to accurately calibrate Joint #2.

The reference point is the center of the ball screw spline shaft during this calibration.

When there is a misalignment between the center of the end effector and the center of the ball screw spline shaft, remove the end effector and execute the calibration of the shaft.

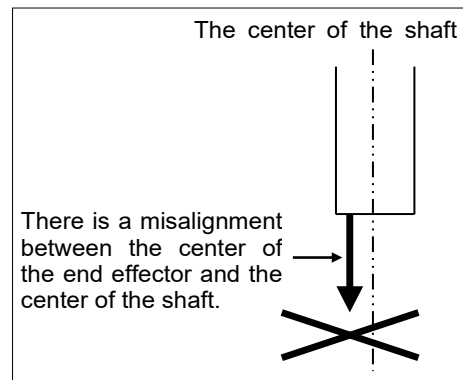

Make a calibration jig as shown in the right figure and attach it on the end of the shaft to make the center of the shaft clear.

Decide a target point and mark a cross (X) on it so that you can easily verify the center of the shaft after switching the arm pose between right and left.

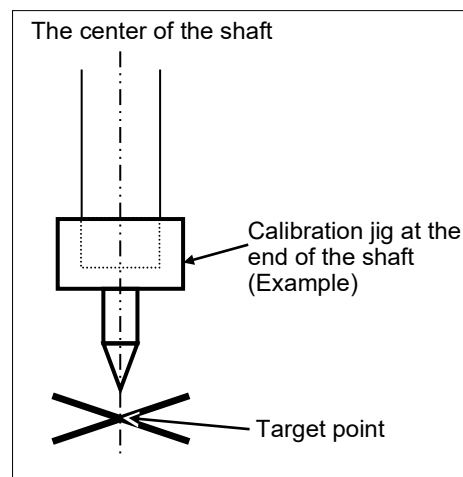

After removing the end effector and executing the calibration, install the end effector and move the Manipulator to the teaching point to verify whether there is a positional gap. If there is a positional gap, fine-tune the installation position of the end effector and teach the point again.

Coordinates for the working point requires calculation in the following cases:

- Teaching the working point by entering the coordinate values (MDI teaching)
- Switching the arm orientation between right and left at a given point
- Using the Pallet command
- Executing CP control (such as liner or circular interpolation)
- Using the Local command
- Pose data specified with relative coordinates <Example: P1+X(100)>
- Vision Guide camera calibrations

Calibration Using Right / Left Arm Orientations

- (1) Check the point data for calibration

Use a point you can easily verify the accuracy within the work envelop of both right and left arm. Then, check the number of points you want to use.
- (2) Open the [Tools menu] - [Robot Manager] - [Control Panel] and click the MOTOR ON.
- (3) Click the <Free All> button in the [Control Panel] to free all joints. Now, all joints are state in free joint and you can move arms by hands.
- (4) Move the arms to the position of point data for calibration in rightly arm orientation.
- (5) From the current position, teach any point data number unused.

(The point is called P1 in this example.)

Specify the point number “1” and click the <Teach> button in the [Jog & Teach].
- (6) Click the <Lock All> button in the [Control Panel] to unlock free joint state of all joints.
- (7) Switch to the lefty arm orientation. Then, move the arm to the same point.

>Jump P1/L:Z(0) ' Change the arm orientation from rightly to lefty

* If there is interference on the way from right to lefty, click the <Free All> button in the [Control Panel] and change the arm orientation to lefty by hands. Then, go to the step (6), (7).
- (8) The joints are slightly out of position.

Adjust the gap with the Z in the Jogging group in the [Jog & Teach]. Then, teach another point data number unused.

(The point is called P2 in this example.)

Specify the point number “2” and click the <Teach> button in the [Jog & Teach].
- (9) Input the new Hof's value.

> Hof's Hof's (1), Hof's (2) + (Ppls (P1,2) + Ppls (P2,2)) / 2, Hof's (3), Hof's (4)
- (10) From the current lefty arm orientation (the position in the step (8)), teach the point data number used in the step (8).

(The point is called P2 in this example.)

Specify the point number “2” and click the <Teach> button in the [Jog & Teach].
- (11) Switch to the rightly arm orientation. Then, make sure the manipulator moves to the correct position.

>Jump P2/R ' Change the arm orientation from lefty to rightly

* If there is interference on the way from lefty to rightly, click the <Free All> button in the [Control Panel] and change the arm orientation to lefty by hands. Then, go to the step (6), (11).

(12) Move the manipulator to other point data and make sure it moves to the correct position.

Teach some more points if required.

* Delete the two points taught for the Joint #2 calibration.

17.4 Reference: Calibration Procedure Without Using Calibration Wizard



This section indicates the calibration without using the calibration wizard of EPSON RC+. For details of calibration using the calibration wizard, refer to “17.2 Calibration Procedure”.

When coordinates for the Manipulator working point require calculation, it is important for Joint #2 to be calibrated accurately. Execute the procedure in “Calibration Using Right / Left Arm Orientations” to accurately calibrate Joint #2. For details, refer to “17.3 Accurate Calibration of Joint #2”.

You cannot calibrate Joint #4 alone because of the structure of the Manipulator. When calibrating Joint #4, you must calibrate Joint #3 and #4 at the same time.



The reference point (a point to identify the position of the Manipulator) needs to be specified for calibration.

Follow steps 1 to 6 described below in order to calibrate the origin.

1. Check the point data for calibration

(1)-1 After the part replacement, execute the calibration using the point data currently registered.

Confirm the point data number (P*) to reconstruct the correct manipulator position.

* Point data before the parts replacement (motor, reduction gear, belt, etc.) is necessary for the calibration.

2. Part Replacement

(2)-1 Replace parts as dictated by this manual.

* Be careful not to injure yourself or damage parts during part replacement.

3. Encoder Initialization

(3)-1 Turn ON the Manipulator when all joints are in the motion range.

(3)-2 Manually move the joint that needs origin alignment to its approximate 0 pulse position.

0 pulse position of Joint #1:
 Position aligned with X-axis in
 Robot coordinate system

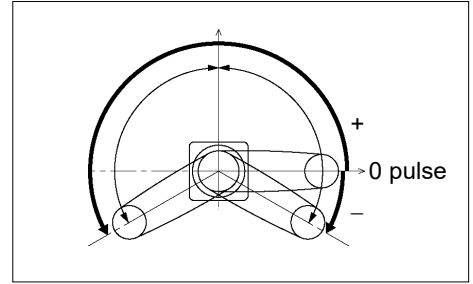

0 pulse position of Joint #2:
 Position where Arms #1 and #2
 are in a straight line
 (Regardless of the Joint #1
 direction.)

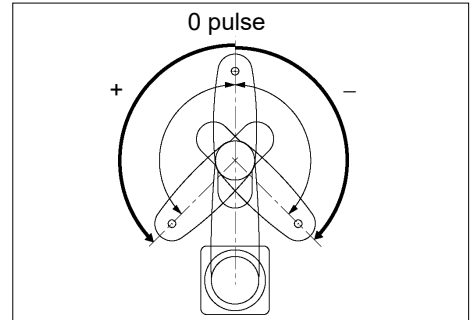

0 pulse position of Joint #3:
 Upper limit position in motion
 range

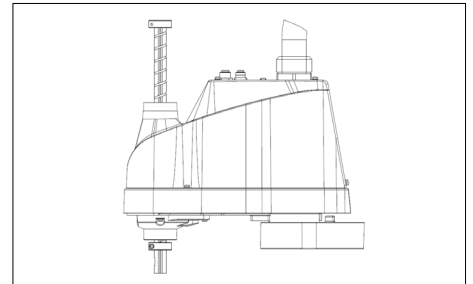

The height of Joint #3 depends
 on manipulator.

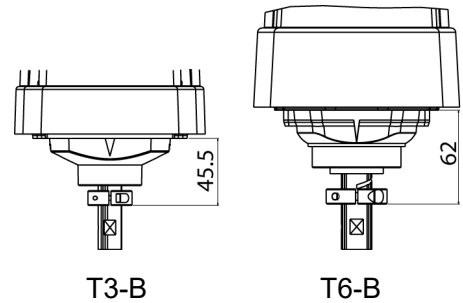

0 pulse position of Joint #4:
 Position where the flat surface
 (or groove in the up/down
 mechanical stop) on the shaft
 faces toward the tip of Arm #2

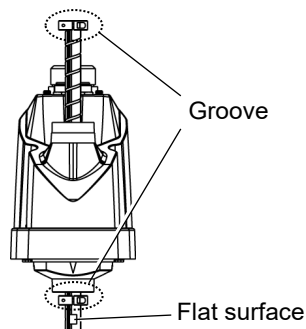
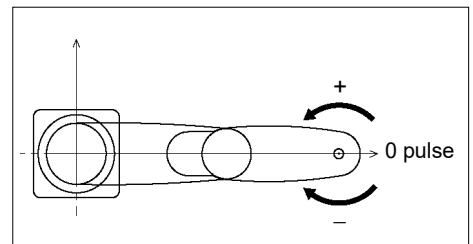

- (3)-3 Connect EPSON RC+ to the Manipulator.

Select a Manipulator to be calibrated. Input as below in the [Command Window] and execute it. (This example uses “robot 1”.)

```
> robot 1
```

- (3)-4 Execute the absolute encoder initialization command.

Input one of the following commands to [Command Window] according to the joint being calibrated.

Joint #1: >EncReset 1

Joint #2: >EncReset 2

Joint #3: >EncReset 3

Joint #4: >EncReset 3, 4

- (3)-5 Reboot the Controller (Manipulator).

Select EPSON RC+ menu-[Tools]-[Controller] and click the <Reset Controller> button.

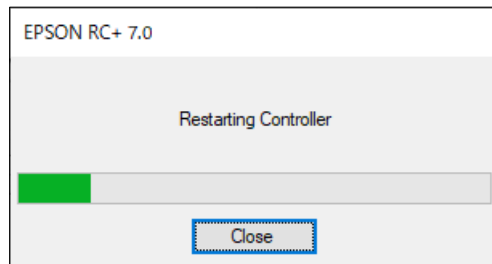

* This window will be disappeared when the Controller starts up.

4. Rough Calibration

- (4)-1 Execute the following command from the menu-[Tools]-[Command Window].

```
>calpls 0,0,0,0
```

* Manipulator does not move.

- (4)-2 Execute one of the following commands according to the joint you want to calibrate from the menu-[Tool]-[Command Window].

Joint #1 >calib 1

Joint #2 >calib 2

Joint #3 >calib 3

Joint #4 >calib 3, 4

5. Calibration (Accurate Positioning)

- (5) -1 Open the [Tools menu] [Robot Manager] [Control Panel] and click the MOTOR ON.

- (5)-2 Click the <Free All> button in the [Control Panel] to free all joints. Now, you can move arms by hands.

(5)-3 Move the Manipulator by hand to a rough position/posture of the calibration point data.

(5)-4 Create the data from the calibration point data.

Enter and execute the following command in [Command Window].

(In this example, P1 is used as the calibration point data.)

```
> Calpls Ppls (P1, 1), Ppls (P1, 2), Ppls (P1, 3),
Ppls (P1, 4)
```

(5)-5 Move the joint to the specified point using a motion command.

For example, when the specified point data is “P1”,
execute “Jump P1:Z(0)” from [Jog & Teach].

* The joint NOT being calibrated moves to the original position.

(5)-6 Accurately align the joint* being calibrated to the specified point using jog commands.

* You must move Joint #3 and #4 to the position when calibrating Joint #4.

Select the jog mode [Joint] from [Jog & Teach] to execute the jog motion.

(5)-7 Execute the calibration.

Input one of the following commands to [Command Window] according to the joint being calibrated.

```
Joint #1 >calib 1
Joint #2 >calib 2
Joint #3 >calib 3
Joint #4 >calib 3, 4
```

6. Accuracy Testing

(6) -1 Move the manipulator to other points and check if it can move without problems. If it does not move to the same position, re-calibrate using another point. You must set the point again if reproducibility cannot be assured through calibration

18. Error Code Table

For details, refer to the following manual.

Status Code / Error Code List

19. Maintenance Parts List

*1 Reduction Gear Unit

A reduction gear unit consists of the following three parts. When replacing the reduction gear units, be sure to always replace the waveform generator, flexspline, and circular spline all together as one set.

Elliptic cam bearing

This waveform generator consists of an elliptic cam with ball bearings on its outer circumference.

The inner ring of bearings is secured to the cam, while the outer ring is capable of flexible deformation through the ball bearings.

Flex gear

A thin, elastic, cup-shaped metal body with gear teeth around the outer circumference of the opening.

Internal gear

A rigid, ring-shaped body with gear teeth on the inner circumference. The circular spline has more teeth than the flex gear does.

Elliptic cam bearing, flex gear, and internal gear are greased. Be careful not to let grease adhere to clothes.

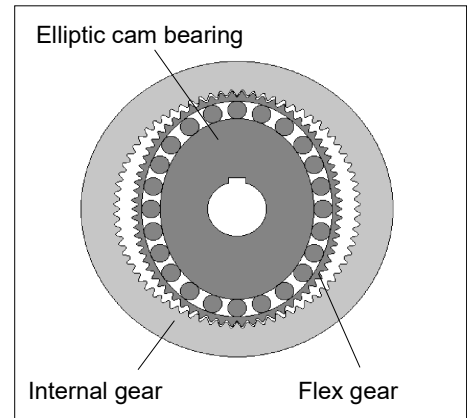

*2 Regarding purchase of grease and adhesive

Due to the chemicals regulations of individual countries (the UN GHS), we are requesting our customers to purchase the grease required for maintenance from the manufacturers listed in the table below as of April 2015.

Regarding purchase of the grease, please contact the following manufacturers. If there is anything unclear, please contact the supplier of your region.

Product name	Manufacturer	URL
THK AFB-LF Grease	THK CO., LTD.	https://www.thk.com/
Sumiplex SFB No.1	Nidec-Shimpo Corporation	https://www.nidec-shimpo.co.jp/
LOCTITE 268	LOCTITE	https://loctite.com

* 3 Overhaul

As a rough indication, perform the overhaul (parts replacement) before reaching 20,000 operation hours of the Manipulator.

The operation hours can be checked in EPSON RC+ - [Controller Status Viewer] dialog - [Motor On Hours].

For details, refer to “2.2 Overhaul (Parts Replacement)”.

19.1 T3-B

Name		Code	NOTE	Reference	Overhaul* 3
Cable Duct Unit		2207936		8.1	
Motor Unit	Joint #1	2207934	200W	9.1	✓
	Joint #2	2207935	100W	10.1	✓
	Joint #3	2216544	100W	11.1	✓
	Joint #4	2216545	100W	12.1	✓
Reduction Gear Unit* 1	Joint #1, 2	1829508	Set of reduction gear units and elliptic cam positioning jig	9.2, 10.2	✓
		1868484	Only Reduction Gear Unit		
Elliptic cam positioning jig		1875189	Assembly jig	9.1, 9.2, 10.1, 10.2	
O-ring	Joint #1	1213266	Between reduction gear unit and Arm #1	9.1	
		1868478	Between reduction gear unit and flange		
		1709549	Between motor and flange		
	Joint #2	1213266	Between reduction gear unit and Arm #1	10.1, 10.2	
		1868478	Between reduction gear unit and Arm #2		
Timing Belt	Joint #3	1554773	Z	11.2	✓
	Joint #4	1709608	U	12.2	✓
Solenoid brake unit		1875188	Z-axis	11.3	✓
Brake Release Switch		2167711		-	
Ball Screw Spline (150st)		1792117		13	✓
Lithium Battery		2113554		14.2	
CPU/DPB Board		2182747		14.1	
Power Board		2182749		14.4	
AMP board		2208322		-	
LED Lamp Unit		2182673		15	
Grease *	Ball Screw Spline: AFB	-	For purchasing grease and adhesive, please contact the supplier in your region.	2.3, 13	
	Reduction Gear Unit: SFB No.1			9.1, 9.2, 10.1, 10.2	
Adhesive *	LOCTITE268	-		8.1	
Arm Cover		1868481	Arm Top Cover (White)	7.1	
Under Cover		1769389	Arm Bottom Cover (Blue)	7.2	
SD Card		2182748		14.3	
TP Plug		2171258		-	

19.2 T6-B

Name		Code	NOTE	Reference	Overhaul* 3
Cable Duct Unit		2207939		8.1	
Motor Unit	Joint #1	2207937	300W	9.1	✓
	Joint #2	2207938	200 W	10.1	✓
	Joint #3	2216544	100 W	11.1	✓
	Joint #4	2216545	100 W	12.1	✓
Reduction Gear Unit *1	Joint #1	1829509	Set of reduction gear units and elliptic cam positioning jig	9.2	✓
	Joint #2	1829510		10.2	✓
	Joint #1	1868485	Only Reduction Gear Unit	9.2	
	Joint #2	1868486		10.2	
Elliptic Cam Positioning Jig		1875190	Assembly Jig	9.1, 9.2, 10.1, 10.2	
O-ring	Joint #1	1510528	Between reduction gear unit and Arm #1	9.1	
		1868480	Between reduction gear unit and flange		
		1520371	Between motor and flange		
	Joint #2	1213267	Between reduction gear unit and Arm #1	10.1, 10.2	
		1868479	Between reduction gear unit and Arm #2		
Timing Belt	Joint #3	1563316	Z	11.2	✓
	Joint #4	1674797	U1	12.2	✓
		1674798	U2		
Solenoid Brake Unit		1875188	Z-axis	11.3	✓
Brake Release Switch		2167711		-	
Ball Screw Spline (200st)		1750572		13	✓
Lithium Battery		2113554		14.2	
CPU/DPB Board		2191143		14.1	
Power Board		2188638		14.4	
AMP Board		2189027		-	
LED Lamp Unit		2182673		15	
Grease *2	Ball Screw Spline: AFB	-	For purchasing grease and adhesive, please contact the supplier in your region.	2.3, 13	
	Reduction Gear Unit: SFB No.1			9.1, 9.2, 10.1, 10.2	
Adhesive *2	LOCTITE268	-		8.1	
Arm Cover		1868482	Arm Top Cover (White)	7.1	
Under Cover		1763918	Arm Bottom Cover (Blue)	7.2	
SD card		2182748		14.3	
TP Plug		2171258		-	

