

# EPSON

## **Industrial Robot: 6-Axis Robots CX-A series Manual**

Original instructions

© Seiko Epson Corporation 2025-2026

Rev.2  
ENM263R8485F

# Table of Contents

- 1. Introduction ..... 8**
  - 1.1 Introduction ..... 9
  - 1.2 Trademarks ..... 9
  - 1.3 Terms of Use ..... 9
  - 1.4 Manufacturer ..... 9
  - 1.5 Contact Information ..... 9
  - 1.6 Disposal ..... 10
  - 1.7 Before Use ..... 10
  - 1.8 Manual Types for This Product ..... 10
  
- 2. CX4 Manipulator ..... 12**
  - 2.1 Safety ..... 13
    - 2.1.1 Conventions Used in This Manual ..... 13
    - 2.1.2 Design and Installation Safety ..... 13
    - 2.1.3 Operation Safety ..... 14
    - 2.1.4 Emergency Stop ..... 15
    - 2.1.5 Safeguard (SG) ..... 16
    - 2.1.6 How to Move Arms with the Electromagnetic Brake ..... 17
      - 2.1.6.1 When using a brake release unit ..... 17
      - 2.1.6.2 When using software ..... 18
    - 2.1.7 Precaution for Operation in Low Power Status ..... 18
    - 2.1.8 Warning Labels ..... 19
      - 2.1.8.1 Warning Labels ..... 19
      - 2.1.8.2 Information Labels ..... 19
    - 2.1.9 Responses for Emergencies or Malfunctions ..... 20
      - 2.1.9.1 When a Collision with the Manipulator Occurs ..... 20
      - 2.1.9.2 Entanglement with the Manipulator ..... 20
  - 2.2 Specifications ..... 22
    - 2.2.1 Model Number ..... 22
    - 2.2.2 Part Names and Motion Range of Each Arm ..... 23
    - 2.2.3 Outer Dimensions ..... 25
      - 2.2.3.1 CX4-A601\*\*\* ..... 25

2.2.4 Standard Work Envelope .....	26
2.2.4.1 CX4-A601*** .....	26
2.2.5 Specifications .....	27
2.2.5.1 Specifications Table .....	27
2.2.5.2 Options .....	27
2.2.6 How to Set the Model .....	27
2.3 Environment and Installation .....	28
2.3.1 Environment .....	28
2.3.2 Manipulator Mounting Dimensions .....	30
2.3.3 From Unpacking to Installation .....	31
2.3.4 Connecting the Cables .....	35
2.3.4.1 How to Connect the Manipulator and M/C Cable .....	37
2.3.4.2 M/C Cable and Controller Connection .....	39
2.3.5 User Wires and Pneumatic Tubes .....	40
2.3.6 Checking the Basic Orientation .....	42
2.3.7 Relocation and Storage .....	43
2.3.7.1 Safety Information for Relocation and Storage .....	43
2.4 Setting the Hand .....	47
2.4.1 Installing the Hand .....	47
2.4.2 Attaching Cameras and Valves .....	48
2.4.3 WEIGHT and INERTIA Settings .....	48
2.4.3.1 WEIGHT Setting .....	51
2.4.3.2 INERTIA Setting .....	56
2.4.4 Safety Information for Auto Acceleration .....	60
2.5 Work Envelope .....	61
2.5.1 Work Envelope Setting by Pulse Range (for Each Joint) .....	61
2.5.1.1 J1 Maximum Pulse Range .....	62
2.5.1.2 J2 Maximum Pulse Range .....	62
2.5.1.3 J3 Maximum Pulse Range .....	63
2.5.1.4 J4 Maximum Pulse Range .....	63
2.5.1.5 J5 Maximum Pulse Range .....	64
2.5.1.6 J6 Maximum Pulse Range .....	64
2.5.2 Setting the Work Envelope by Mechanical Stops .....	65
2.5.2.1 Setting the Arm #1 Work Envelope .....	65
2.5.3 Restriction of Manipulator Operation by Joint Angle Combination .....	66

---

2.5.4 Coordinate System .....	68
2.5.5 Changing the Robot .....	70
2.5.6 Setting the Rectangular Range in the XY Coordinate System of the Manipulator .....	72
2.6 Options .....	73
2.6.1 Brake Release Unit .....	73
2.6.1.1 Power Cable .....	74
2.6.1.2 Installing the Brake Release Unit .....	75
2.6.1.3 Removing the Brake Release Unit .....	75
2.6.1.4 How to Use the Brake Release Unit .....	76
2.6.2 Camera Plate Unit .....	76
2.6.3 C4 Compatible Flange .....	81
2.6.4 Variable Mechanical Stop .....	83
2.6.5 External Wiring Kit .....	84
2.6.6 User Wires and Pneumatic Tubes .....	92
<b>3. CX7-A Manipulator .....</b>	<b>93</b>
3.1 Safety .....	94
3.1.1 Conventions Used in This Manual .....	94
3.1.2 Design and Installation Safety .....	94
3.1.3 Operation Safety .....	95
3.1.4 Emergency Stop .....	96
3.1.5 Safeguard (SG) .....	96
3.1.6 How to Move Arms with the Electromagnetic Brake .....	97
3.1.6.1 When using a brake release unit .....	98
3.1.6.2 When using software .....	98
3.1.7 Precaution for Operation in Low Power Status .....	99
3.1.8 Warning Labels .....	99
3.1.8.1 Warning Labels .....	100
3.1.8.2 Information Labels .....	100
3.1.9 Responses for Emergencies or Malfunctions .....	101
3.1.9.1 When a Collision with the Manipulator Occurs .....	101
3.1.9.2 Entanglement with the Manipulator .....	101
3.2 Specifications .....	102
3.2.1 Model Number .....	102
3.2.2 Part Names and Motion Range of Each Arm .....	103

---

---

3.2.3 Outer Dimensions .....	105
3.2.3.1 CX7-A701*** .....	105
3.2.3.2 CX7-A901*** .....	106
3.2.4 Standard Work Envelope .....	107
3.2.4.1 CX7-A701*** .....	107
3.2.4.2 CX7-A901*** .....	109
3.2.5 Specifications .....	110
3.2.5.1 Specifications Table .....	110
3.2.5.2 Options .....	110
3.2.6 How to Set the Model .....	110
3.3 Environment and Installation .....	111
3.3.1 Environment .....	111
3.3.2 Manipulator Mounting Dimensions .....	113
3.3.3 From Unpacking to Installation .....	116
3.3.4 Connecting the Cables .....	120
3.3.5 User Wires and Pneumatic Tubes .....	122
3.3.6 Checking the Basic Orientation .....	124
3.3.7 Relocation and Storage .....	125
3.3.7.1 Safety Information for Relocation and Storage .....	125
3.4 Setting the Hand .....	130
3.4.1 Installing the Hand .....	130
3.4.2 Attaching Cameras and Valves .....	131
3.4.3 WEIGHT and INERTIA Settings .....	132
3.4.3.1 WEIGHT Setting .....	135
3.4.3.2 INERTIA Setting .....	140
3.4.4 Safety Information for Auto Acceleration .....	144
3.5 Work Envelope .....	146
3.5.1 Work Envelope Setting by Pulse Range (for Each Joint) .....	146
3.5.1.1 Joint #1 Maximum Pulse Range .....	147
3.5.1.2 Joint #2 Maximum Pulse Range .....	147
3.5.1.3 Joint #3 Maximum Pulse Range .....	148
3.5.1.4 Joint #4 Maximum Pulse Range .....	149
3.5.1.5 Joint #5 Maximum Pulse Range .....	149
3.5.1.6 Joint #6 Maximum Pulse Range .....	150

---

3.5.2 Setting the Work Envelope by Mechanical Stops .....	150
3.5.2.1 Setting the Joint #1 Work Envelope .....	150
3.5.3 Restriction of Manipulator Operation by Joint Angle Combination .....	151
3.5.4 Coordinate System .....	154
3.5.5 Changing the Robot .....	157
3.5.6 Setting the Rectangular Range in the XY Coordinate System of the Manipulator .....	158
3.6 Options .....	159
<b>4. Periodic Inspection .....</b>	<b>160</b>
4.1 CX4 Manipulator Periodic Inspection .....	161
4.1.1 Inspection .....	161
4.1.1.1 Inspection Schedule .....	161
4.1.1.2 Inspection Details .....	162
4.1.2 Overhaul (Parts Replacement) .....	163
4.1.3 Applying Grease .....	163
4.1.4 Tightening the Hexagon Socket Head Cap Bolts .....	164
4.2 CX7 Manipulator Periodic Inspection .....	165
4.2.1 Inspection .....	165
4.2.1.1 Inspection Schedule .....	165
4.2.1.2 Inspection Details .....	166
4.2.2 Overhaul (Parts Replacement) .....	167
4.2.3 Applying Grease .....	167
4.2.4 Tightening the Hexagon Socket Head Cap Bolts .....	168
<b>5. Appendix .....</b>	<b>170</b>
5.1 Appendix A: Specifications Table .....	171
5.1.1 CX4 Specifications .....	171
5.1.2 CX7 Specifications .....	178
5.2 Appendix B: Stopping Time and Stopping Distance at Emergency Stop .....	186
5.2.1 CX4-A Stopping Time and Stopping Distance at Emergency Stop .....	188
5.2.2 CX7-A Stopping Time and Stopping Distance at Emergency Stop .....	207
5.2.3 Supplementary Information regarding the Stopping Time and Stopping Distance at Emergency Stop .....	221
5.2.3.1 How to check the stopping time and stopping distance in the customer's environment .....	221
5.2.3.2 Commands that can be useful when measuring stopping time and stopping distance .....	222

---

5.3 Appendix C: Stopping Time and Stopping Distance When Safeguard is Open .....	223
5.3.1 CX4-A Stopping Time and Stopping Distance When Safeguard is Open .....	225
5.3.2 CX7-A Stopping Time and Stopping Distance When Safeguard is Open .....	244
5.3.3 Supplementary Information regarding the Stopping Time and Stopping Distance when the Safeguard is Open .....	258
5.3.3.1 How to check the stopping time and stopping distance in the customer's environment .....	258
5.3.3.2 Commands that can be useful when measuring stopping time and stopping distance .....	259

# 1. Introduction

## 1.1 Introduction

Thank you for purchasing this Epson robot system. This manual provides the information necessary for correctly using the robot system.

Before using the system, please read this manual and related manuals to ensure correct use.

After reading this manual, store it in an easily accessible location for future reference.

Epson conducts rigorous testing and inspection to ensure that the performance of our robot systems meets our standards. Please note that if the Epson robot system is used outside the operating conditions described in the manual, the product will not perform up to its basic performance.

This manual describes potential hazards and problems that are foreseen. To use the Epson robot system safely and correctly, be sure to follow the safety information contained in this manual.

## 1.2 Trademarks

Microsoft, Windows, and the Windows logo are either registered trademarks or trademarks of Microsoft Corporation in the United States and/or other countries. All other company names, brand names, and product names are registered trademarks or trademarks of their respective companies.

## 1.3 Terms of Use

No part of this instruction manual may be reproduced or reprinted in any form without express written permission.

The information in this document is subject to change without notice.

Please contact us if you find any errors in this document or if you have any questions about the information in this document.

## 1.4 Manufacturer

**SEIKO EPSON CORPORATION**

## 1.5 Contact Information

Contact information details are listed in the "Supplier" section in the following manual.

Note that the contact information may vary depending on your region.

"Safety Manual - Contact Information"

The Safety Manual is also available at the following site.

URL: <https://download.epson.biz/robots/>



## 1.6 Disposal

When disposing of this product, please do so in accordance with the laws and regulations of your country.

## 1.7 Before Use

Before using this manual, be sure that you understand the following information.

### Control system configuration

The CX-A series Manipulators are made up of a combination of the following Controller and software.

Manipulator	Controller	Software
CX-A series	RC800-A	Epson RC+ 8.0

### Setting from the software

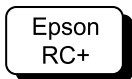

This manual contains the procedures for configuring the settings from the software. Use of this software is indicated by the above mark.

### Controller power on (off)

In this manual, an instruction to "Turn on (off) the Controller power" means to turn on the power for the hardware that makes up your Controller.

### Images used in this manual

The photos and illustrations of the Manipulators shown in this manual may differ in shape and appearance from your Manipulator due to the time it was shipped, specifications, and other factors.

## 1.8 Manual Types for This Product

This describes the typical types of manuals for this product and presents an overview of their content.

### ▪ Safety Manual

This manual contains safety-related information intended for all people who use this product. It also guides the user through the process from unpacking to usage and the manuals that should be referred to next. Please read this manual first.

- Safety information and residual risks of robot systems
- Declaration of Conformity
- Training
- Process from unpacking to usage

### ▪ Robot Controller Safety Function Manual

This describes the procedures for configuring the safety functions of this product and the configuration software. It is primarily intended for those who design robot systems.

### ▪ RC800-A Manual

This manual describes the installation of the entire robot system and explains the specifications and functions of the Controller. It is primarily intended for those who design robot systems.

- Robot system installation procedure (specific details on the process from unpacking to usage)
- Controller daily inspection points
- Controller specifications and basic functions

#### ▪ **CX-A series Manual**

This manual describes the specifications and functions of the Manipulator. It is primarily intended for those who design robot systems.

- Manipulator installation, technical information needed for design, function and specification tables, etc.
- Manipulator daily inspection points

#### ▪ **Status Code/Error Code List**

This provides the code numbers displayed on the Controller and messages displayed in the message area of the software. It is primarily intended for those who design and program robot systems.

#### ▪ **Epson RC+ User's Guide**

This manual presents an overview of the program development software.

#### ▪ **Epson RC+ SPEL+ Language Reference**

This manual explains the robot programming language SPEL+.

### **Other manuals**

Manuals are available for each option.

### **Maintenance and servicing manuals**

Manuals for maintenance and servicing are not included with the product. Maintenance should be performed by people who have received maintenance training provided by Epson and the suppliers. For more information, please contact the supplier.

## 2. CX4 Manipulator

This chapter contains information for setup and operation of the Manipulators.

Please read this chapter thoroughly before setting up and operating the Manipulators.

## 2.1 Safety

The Manipulator and its related equipment should be unpacked and transported by people who have received installation training provided by Epson and the suppliers. Also, the laws and regulations of the installation country must be followed.

Before use, please read this manual and other related manuals to ensure correct use. After reading this manual, store it in an easily accessible location for future reference.

This product is intended for transporting and assembling parts in a safely isolated area.

### 2.1.1 Conventions Used in This Manual

The following symbols are used in this manual to indicate important safety information. Be sure to read the descriptions shown with each symbol.

#### WARNING

This symbol indicates an imminently hazardous situation which, if operation is not performed properly, will result in death or serious injury.

#### WARNING

This symbol indicates a potentially hazardous situation which, if operation is not performed properly, could result in an injury due to electric shock.

#### CAUTION

This symbol indicates a potentially hazardous situation which, if operation is not performed properly, may result in a minor or moderate injury or in property damage only.

### 2.1.2 Design and Installation Safety

The robot system should be designed and installed by people who have received installation training provided by Epson and the suppliers.

Design personnel should refer to the following manuals:

- "Safety Manual"
- "Controller Manual"
- "Manipulator Manual"

Refer to the following section for the installation safety information.

#### **Environment and Installation**

Be sure to read this section and follow the safety information before installation to ensure that the installation work is performed safely.

## 2.1.3 Operation Safety

The following items are safety precautions for operating personnel:

### WARNING

- Be sure to read the Safety Manual before use. Operating the robot system without understanding the safety information can be extremely dangerous and may result in serious injury or severe equipment damage.
- Before operating the robot system, make sure that no one is inside the safety barriers. The robot system can be operated in the teaching operation mode even when someone is inside the safety barriers. Even though the motion of the Manipulator is always restricted (low speed and low power) to ensure operator safety, an unexpected movement by the Manipulator can be extremely dangerous and may cause serious safety problems.
- If the Manipulator moves abnormally during operation of the robot system, immediately press the emergency stop switch.

### WARNING

- To perform the power supply lockout, remove the power plug. Be sure to connect the AC power cable to a power outlet. Do not connect it directly to a factory power source.
- Before performing any replacement work, inform others in the area that you are working, and then turn off the Controller and related equipment, and unplug the power cable from the power source. Performing any work procedure with the power turned on is extremely dangerous and may result in electric shock and/or malfunction of the robot system.
- Do not connect or disconnect the connector of the M/C cable while the Controller is turned on. There is a risk the Manipulator may malfunction, which is extremely hazardous. Also, performing any work procedure with the power turned on may result in electric shock and/or malfunction of the robot system.

### CAUTION

- Whenever possible, only one person should operate the robot system. If it is necessary to operate with more than one person, ensure that all personnel communicate with each other and take all necessary safety precautions.
- If the Manipulator is operated repeatedly with each joint having an operating angle of 5° or less, the bearings used in the joints are likely to cause oil film shortage. Repeated operation may cause premature damage. To prevent premature damage, operate the Manipulator to move each joint to an angle of 30° or more about once per hour.
- When the robot is operating at low speed (Speed: 5 to 20%), vibration (resonance) may occur continuously during operation depending on the combination of the arm orientation and hand load. Vibration occurs due to the natural vibration frequency of the arm and can be reduced by taking the following measures:
  - Changing the robot speed
  - Changing the teach points
  - Changing the hand load

## 2.1.4 Emergency Stop

Each robot system needs equipment that will allow the operator to immediately stop the system's operation. Install an emergency stop device by using emergency stop input from the Controller or other equipment.

Before using the emergency stop switch, be aware of the following points.

The emergency stop switch should be used to stop the Manipulator only in case of emergencies

Besides pressing the emergency stop switch when an emergency occurs, to stop the Manipulator during program operation, use the Pause or STOP (program stop) statements assigned to a standard I/O.

The Pause and STOP statements do not turn off motor energization, and so the brake is not locked.

To place the robot system in emergency stop mode in a non-emergency (normal) situation, press the emergency stop switch while the Manipulator is not operating.

Do not press the emergency stop switch unnecessarily while the Manipulator is operating normally.

It could shorten the lifespan of the following components.

- Brakes

The brakes will be locked, which will shorten the lifespan of the brakes due to worn brake friction plates.

Normal brake lifespan: About 2 years (when the brakes are used 100 times/day)

However, when the emergency stop switch is pressed more than necessary, it will affect the normal relay lifespan (about 20,000 times).

- Reduction gears

An emergency stop applies an impact to the reduction gear, which can shorten its life.

If the Manipulator is stopped by turning off the Controller while it is operating, the following problems may occur.

- Reduced life and damage to reduction gear
- Position shift at the joints

If a power outage or other unavoidable Controller power-off occurs during Manipulator operation, check the following points after power is restored.

- Damage in reduction gear
- Shifting of the joints from their proper positions

If there was any shifting, maintenance is required. For more information, please contact the supplier.

### Stopping distance of emergency stop

The Manipulator during operation cannot stop immediately after the emergency stop switch is pressed. Also, the stopping time and movement distance vary depending on the following factors.

- Hand weight, WEIGHT setting, ACCEL setting, workpiece weight, SPEED setting, movement posture, etc.

For the stopping time and movement distance of the Manipulator, refer to the following section.

### [Appendix B: Stopping Time and Stopping Distance at Emergency Stop](#)

## 2.1.5 Safeguard (SG)

To maintain a safe working zone, safety barriers must be set up around the Manipulator, and safeguards must be installed at the entrance and exit of the safety barriers.

The term "safeguard" as used in this manual refers to a safety device with an interlock that allows entry into the safety barriers. Specifically, this includes safety door switches, safety barriers, light curtains, safety gates, safety floor mats, and so on. The safeguard is an input that informs the Robot Controller that an operator may be inside the safeguard area. You must assign at least one Safeguard (SG) in Safety Function Manager.

When the safeguard is opened, Protective Stop operates to change to the safeguard open state (display: SO).

- Safeguard open  
Operations are prohibited. Further robot operation is not possible until either the safeguard is closed, the latched state is released, and a command is executed, or the TEACH or TEST operation mode is turned on and the enable circuit is activated.
- Safeguard closed  
The robot can operate automatically in an unrestricted (high power) state.

### WARNING

- If a third party accidentally releases the safeguard while an operator is working inside the safety barriers, this may result in a hazardous situation. To protect the operator working inside the safety barriers, implement measures to lock out or tag out the latch release switch.
- To protect operators working near the robot, be sure to connect a safeguard switch and make sure that it works properly.

### Installing safety barriers

When installing safety barriers within the maximum range of the Manipulator, combine safety functions such as SLP. Carefully take into account the size of the hand and the workpieces to be held so that no interference occurs between the operating parts and the safety barriers.

### Installing safeguards

Design the safeguards so that they satisfy the following requirements:

- When using a key switch type safety device, use a switch that forcibly opens the interlock contacts. Do not use switches that open their contacts using the spring force of the interlock.
- When using an interlock mechanism, do not disable the interlock mechanism.

### Considering the stopping distance

During operation, the Manipulator cannot stop immediately even if the safeguard is opened. Also, the stopping time and movement distance vary depending on the following factors.

- Hand weight, WEIGHT setting, ACCEL setting, workpiece weight, SPEED setting, movement posture, etc.

For the stopping time and movement distance of the Manipulator, refer to the following section.

### [Appendix C: Stopping Time and Stopping Distance When Safeguard is Open](#)

### Precautions for safeguard operation

Do not open the safeguard unnecessarily while the motor is energized. Frequent safeguard inputs will reduce the life of the relay.

- Normal relay lifespan: About 20,000 times

## 2.1.6 How to Move Arms with the Electromagnetic Brake

There are two methods to release the electromagnetic brake. Follow either method to release the electromagnetic brake and move the arms manually.

- **When using a brake release unit**  
Follow the method when you just unpack the delivered boxes or when the Controller does not start up yet.
- **When using software**  
Follow the method when you can use the software.

While the electromagnetic brake is on (such as in emergency mode), you cannot move any arm by pushing manually.

### Arm Motion

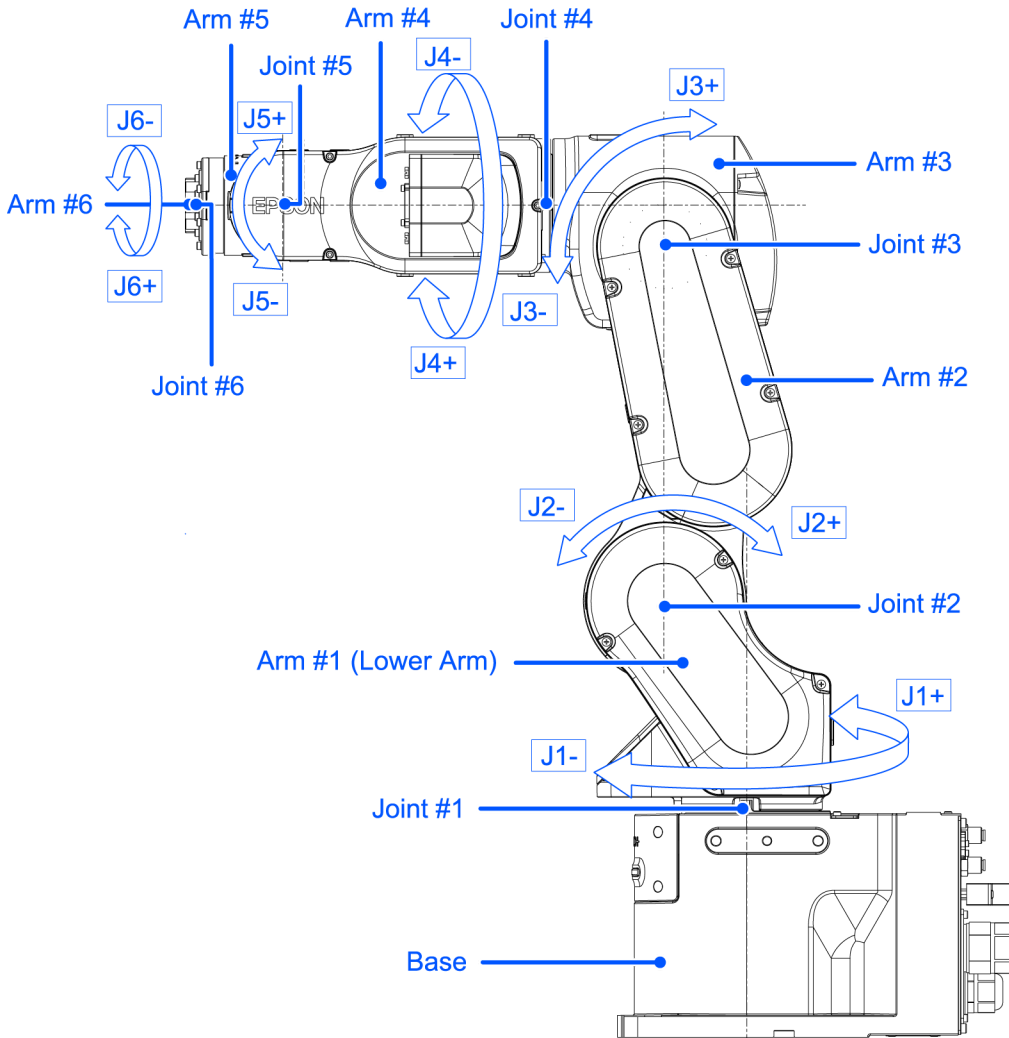

### 2.1.6.1 When using a brake release unit

This series has the Brake Release Unit as an option. For details, refer to the following section.

#### Options

## 2.1.6.2 When using software

**⚠ CAUTION**

- Normally, release the brakes of joints one at a time. If the brakes of two or more joints must be released simultaneously due to unavoidable reasons, use extreme care. Releasing the brakes of multiple joints simultaneously may cause the arm to fall in an unexpected direction, resulting in hands or fingers getting caught or damage or failure of the Manipulator.
- After releasing the brake, the arm may fall by its own weight or move to the unexpected direction. Make sure to prepare a countermeasure to prevent the arm from falling and check the operation environment is safe.
- Before releasing the brake, be sure to keep the emergency stop switch in an easily accessible location so that you can immediately press it if necessary. Otherwise, if the emergency stop switch is not easily accessible, you will be unable to immediately stop the arm falling due to an erroneous operation, which could lead to Manipulator damage or breakdown.

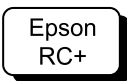

After releasing the Emergency Stop switch, execute the following command in [Command Window].

```
>Reset
>Brake Off, [The number (from 1 to 6) corresponding to the arm whose brake will be turned off]
```

Execute the following command to turn on the brake again.

```
>Brake On, [The number (from 1 to 6) corresponding to the arm whose brake will be turned on]
```

## 2.1.7 Precaution for Operation in Low Power Status

In the low power status, the Manipulator operates at low speed and low torque. However, comparatively high torque as shown in the table below may be generated to support the Manipulator’s own weight. Carefully operate the Manipulator since it may get your hands or fingers caught during operation. The Manipulator may also collide with peripheral equipment and cause equipment damage to or malfunction of the Manipulator.

**Maximum joint output torque in low power status [Unit: N·m]**

Joint		#1	#2	#3	#4	#5	#6
Joint Torque	CX4-A601\***	45.63	112.10	56.16	19.31	16.68	9.55
	CX4-A601***W	136.90					

**⚠ CAUTION**

- Carefully operate the Manipulator in the low power status. A comparatively high joint torque may be generated. It may cause your hands and fingers caught and/or cause equipment damage to or malfunction of the Manipulator as it may collide with peripheral equipment.

## 2.1.8 Warning Labels

The Manipulator has the following warning labels. Specific hazards exist in the vicinity of areas with the warning labels. Be thoroughly careful in handling. To ensure that the Manipulator is operated and maintained safely, be sure to follow the safety information and warnings indicated on the warning labels. Also, do not tear, damage, or remove these warning labels.

### 2.1.8.1 Warning Labels

A



Touching any internal electrified parts while the power is turned on may cause electric shock.

B



HOT Be careful not to burn yourself.

C



When releasing the brakes, be careful of the arm falling due to its own weight.

This warning label is attached on the Manipulator and optional brake release unit as well.

When the brake release unit is used:

When using a brake release unit to release brakes, refer to the following section.

[How to Move Arms with the Electromagnetic Brake](#)

### 2.1.8.2 Information Labels

1

This indicates the product name, model name, serial number, information of supported laws and regulations, product specifications (Weight, MAX.REACH, MAX.PAYLOAD, AIR PRESSURE, Motor Power), Main document No., manufacturer, importer, date of manufacture, country of manufacture, and the like.

For details, see the label affixed to the product.

2



This indicates the position for mounting eyebolts. Refer to the following section for examples of using eyebolts.

Environment and Installation

Location of Labels

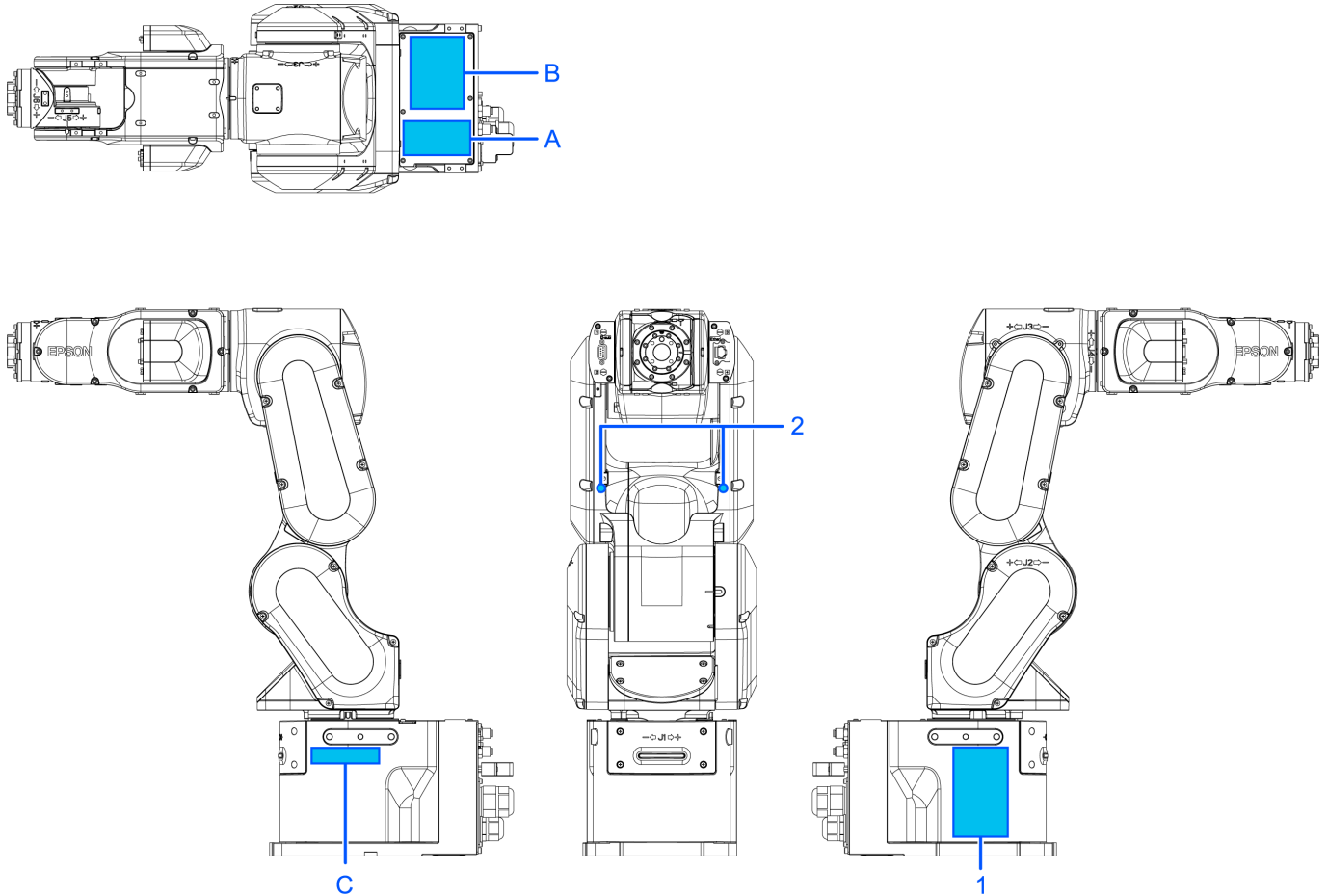

2.1.9 Responses for Emergencies or Malfunctions

2.1.9.1 When a Collision with the Manipulator Occurs

If the Manipulator has collided with a mechanical stop, peripheral device, or other object, discontinue use and contact the supplier.

Also, if the Manipulator collides with mechanical stops or peripheral devices, the following problems may occur.

- Reduction of the life and damage of the reduction gear unit
- Position gap at the joints

2.1.9.2 Entanglement with the Manipulator

When the operator is caught between the Manipulator and a mechanical part such as a base table, press the emergency stop switch to release the brake on the subject arm, and then move the arm by hand.

How to release a brake

- When using a brake release unit, refer to the following section.

**Brake Release Unit**

- When using software, refer to the following section.

**When using software**

## 2.2 Specifications

### 2.2.1 Model Number

CX4 - A 6 0 1 S

[a][b][c][d][e]

- a: Arm length
  - 6: 600 mm
- b: Brake equipment
  - 1: Brakes on all joints
- c: Environment
  - S: Standard \*1
  - C: Cleanroom & ESD (anti-static) \*1
  - P: Protection \*2
- d: Mounting type
  - : Table top mounting
  - R: Ceiling mounting \*3
  - W: Wall mounting \*3
- e: Internal wiring
  - : Available
  - -NIW: Not available

\*1 Equivalent to IP20

\*2. IP67

\*3 Manipulators are set to "Table Top mounting" or "Wall mounting" at shipment. To use the Manipulators as "Ceiling mounting", you need to change the model settings.

- **Changing the Robot**
- "Epson RC+ User's Guide - Robot Configuration"

## 2.2.2 Part Names and Motion Range of Each Arm

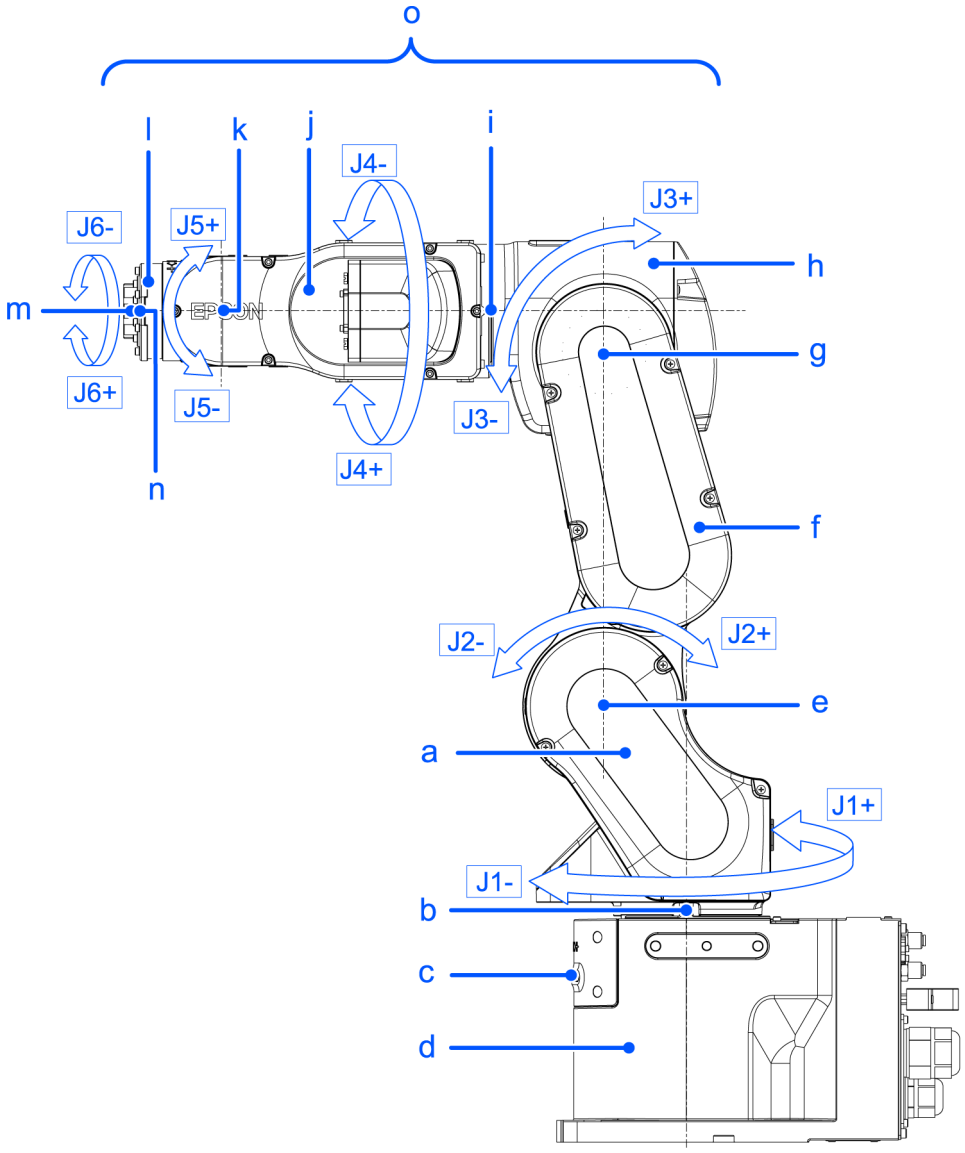

Symbol	Description
a	Arm #1 (Lower Arm)
b	Joint #1 (The whole Manipulator revolves.)
c	LED Lamp (This lamp lights up while the motors are on.)
d	Base
e	Joint #2 (The lower arm swings.)
f	Arm #2
g	Joint #3 (The upper arm swings.)
h	Arm #3
i	Joint #4 (The wrist revolves.)
j	Arm #4
k	Joint #5 (The wrist swings.)

Symbol	Description
l	Arm #5
m	Arm #6
n	Joint #6 (The hand rotates.)
o	Upper Arm (Arms #3 to #6)

**KEY POINTS**

When the LED lamp is lighting or the Controller power is on, the current is being applied to the Manipulator. (The LED lamp may not be seen depending on the Manipulator's posture. Be thoroughly careful. Performing any work procedure with the power turned on is extremely dangerous and may result in electric shock and/or malfunction of the robot system. Before starting any maintenance work, be sure to turn off the Controller.

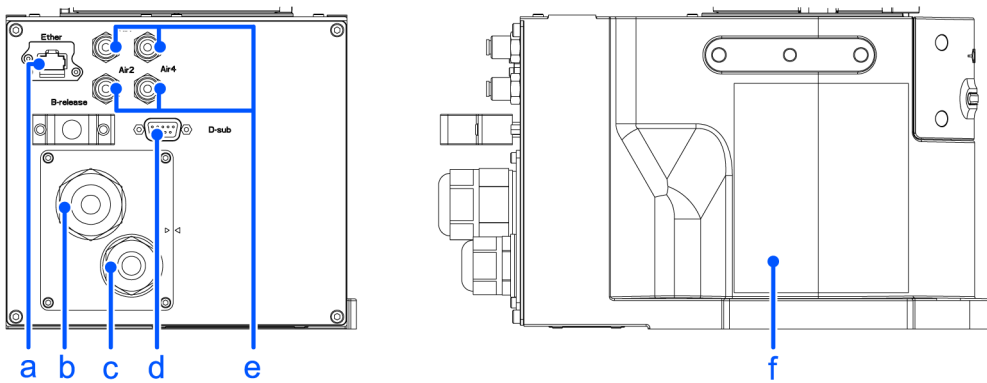

Symbol	Description
a	User cable connector (Ethernet connector)
b	Power cable
c	Signal cable
d	User cable connector (9-pin D-sub connector)
e	Fitting for ø4 mm tube
f	Face plate (serial number of Manipulator)

## 2.2.3 Outer Dimensions

### 2.2.3.1 CX4-A601\*\*\*

(Units: mm)

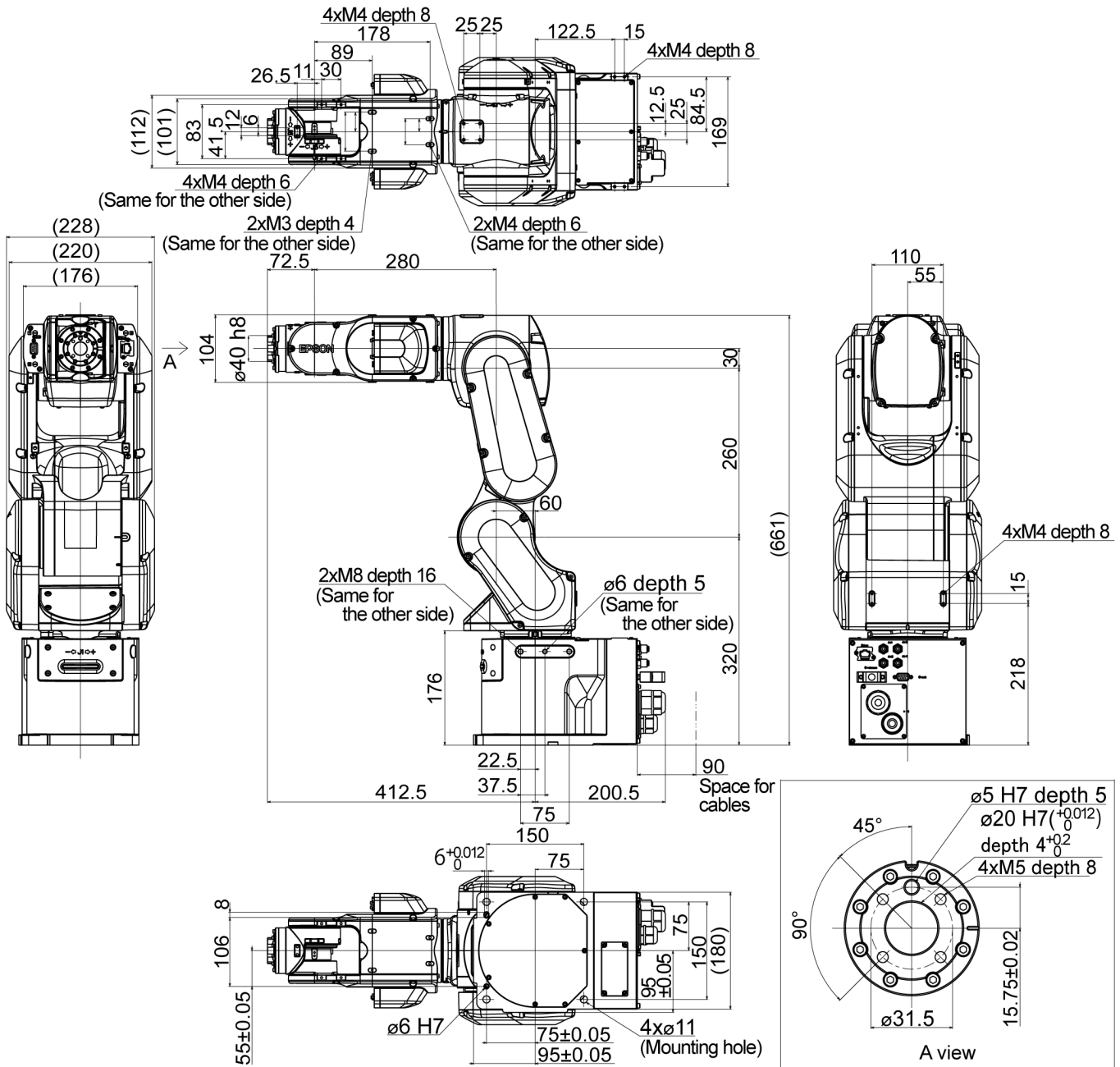

depth = depth of threaded hole

## 2.2.4 Standard Work Envelope

### 2.2.4.1 CX4-A601\*\*\*

(Units: mm)

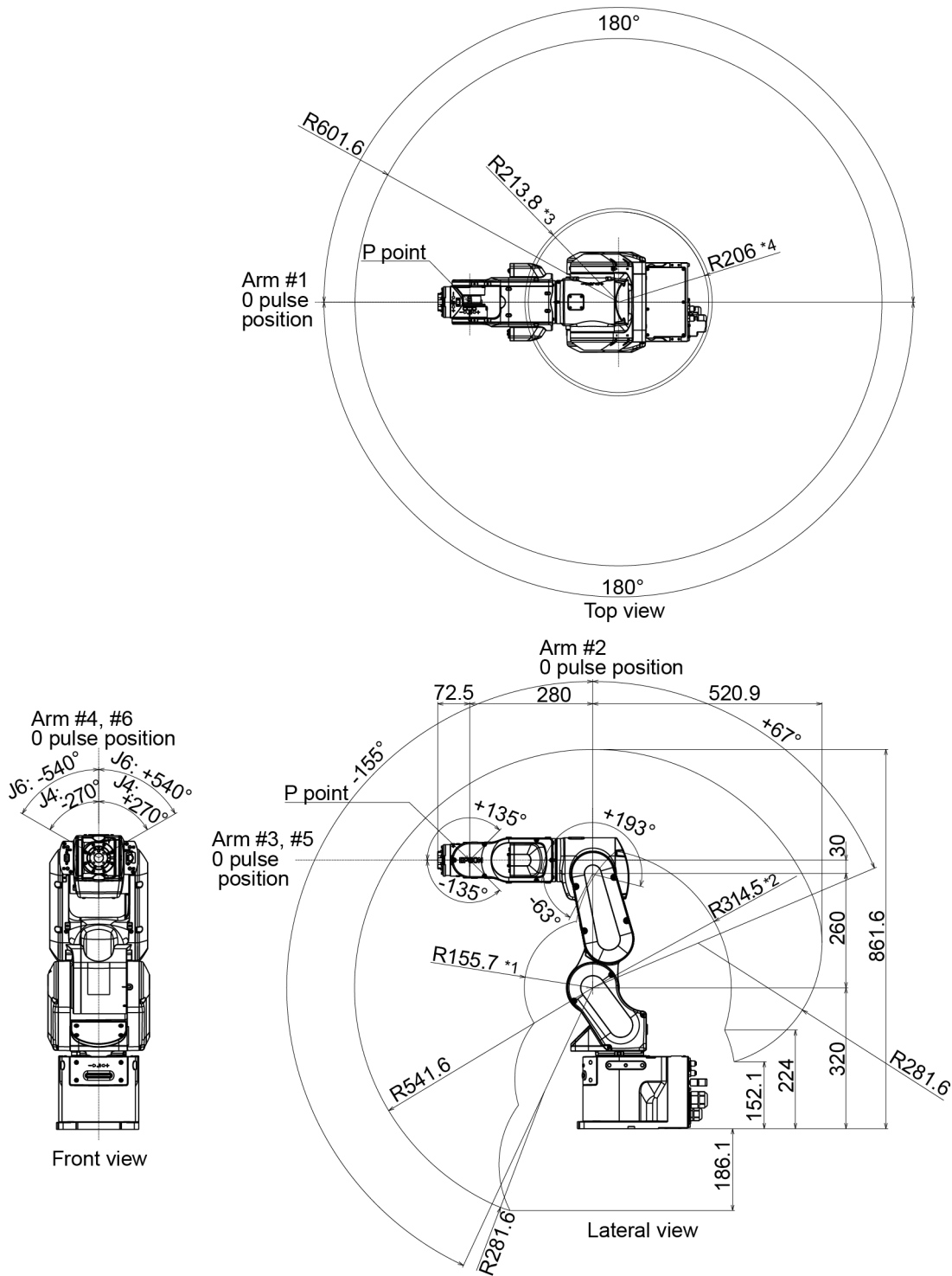

(deg. = °)

\*1: P point from lateral with Joint #3 declining  $-63^\circ$  (Joint #2 center – P point center)

\*2: P point from lateral with Joint #3 declining  $+193^\circ$  (Joint #2 center – P point center)

\*3: P point from top with Joint #3 tilting up  $-63^{\circ}$  (Joint #1 center – P point center)

\*4: P point from top with Joint #3 tilting up  $+193^{\circ}$  (Joint #1 center – P point center)

### CAUTION

- Pay attention to the arm pose of the basic arms (Arms #1, #2, and #3) when operating the Manipulator. Arm #5 moves keeping a constant angle regardless of the arm pose. Depending on the arm pose of the basic arms, the wrist may collide with the Manipulator. The collision may cause equipment damage to and/or malfunction of the Manipulator.

## 2.2.5 Specifications

### 2.2.5.1 Specifications Table

For the specifications tables of each model, refer to the following section.

[CX4 Specifications](#)

### 2.2.5.2 Options

For details, refer to the following section.

[Options](#)

## 2.2.6 How to Set the Model

The Manipulator model for your system has been set before shipment from the factory.

### CAUTION

- If changing the setting of the Manipulator model, be responsible and absolutely certain that the wrong Manipulator model is not set. Incorrect setting of the Manipulator model may result in abnormal or no operation by the Manipulator and could even cause safety problems.

If a custom specifications number (MT\*\*\*) or (X\*\*\*) is written on the face plate (serial number label), the Manipulator has custom specifications.

Models with custom specifications may require a different setting procedure. Check the custom specifications number, and contact the supplier for more information.

The Manipulator model is set from software. For details, refer to the following manual.

"Epson RC+ User's Guide - Robot Configuration"

## 2.3 Environment and Installation

The robot system should be designed and installed by people who have received installation training provided by Epson and the suppliers. Also, the laws and regulations of the installation country must be followed.

### 2.3.1 Environment

To ensure that the robot system operates and maintains maximum performance and to ensure its safe use, the robot system should be installed in an environment that meets the following requirements.

Item	Conditions
Ambient temperature *	Installation: 5 to 40°C Transport, storage: -20 to 60°C
Ambient relative humidity	Installation: 10 to 80% (no condensation) Transport, storage: 10 to 90% (no condensation)
Fast transient burst noise	1 kV or less (signal line)
Electrostatic noise	4 kV or less
Altitude	1000 m or less

\* The ambient temperature requirement is for the Manipulator only. For details on the environment requirements for the connected Controller, refer to the Robot Controller manual.

 **KEY POINTS**

---

When used in a low-temperature environment near the minimum temperature specified in the product specifications, or when the unit is idle for a long period of time during holidays or at night, a collision detection error or similar error may occur immediately after the start of operation due to high resistance in the drive unit. In such cases, warm-up operation for about 10 minutes is recommended.

 **KEY POINTS**

---

If there are conductive objects such as fences or ladders within 2.5 m of the Manipulator, these objects must be grounded.

Also, depending on the environmental specifications of the Manipulator, the following requirements must be met.

Environmental Specifications	Conditions
S, C, P	<ul style="list-style-type: none"> <li>- Install indoors.</li> <li>- Keep away from direct sunlight.</li> <li>- Keep away from shocks or vibrations.</li> <li>- Keep away from sources of electric noise.</li> <li>- Keep away from explosive areas.</li> <li>- Keep away from large quantities of radiation.</li> </ul>
S, C	<ul style="list-style-type: none"> <li>- Keep away from dust, oily smoke, salinity, metal powder, and other contaminants.</li> <li>- Keep away from flammable or corrosive liquids and gases.</li> <li>- Keep away from organic solvents, acids, alkalis, and chlorine cutting fluids.</li> <li>- Keep away from water.</li> </ul>

The following items should also be taken into consideration for the installation environment of Manipulators with protected-models.

- These are compliant with the IP67 protection class (IEC 60529, JIS C0920). The Manipulators can be used in environments where the possibility of dust, water, and water-soluble cutting oil falling of the Manipulator exists.
- They can be installed in environments where dust, oil smoke, metal powder, and similar substances are airborne, but they are not suitable for use with nitrile rubber oil seals, O-rings, packings, liquid gaskets, or other substances that impair sealing performance.
- The Manipulator cannot be used in environments exposed to liquids or airborne droplets that are corrosive such as acids or alkalis.
- In environments that are exposed to airborne droplets containing salt, rust may also form on the Manipulator.
- Manipulator surfaces are generally oil-resistant, but if special oils are to be used, oil resistance should be checked before use. For more information, please contact the supplier.
- In environments with rapid changes in temperature and humidity, condensation may form inside the Manipulator.
- When handling food directly, it is necessary to make sure that the Manipulator is not likely to contaminate the food. For more information, please contact the supplier.
- The Controllers used with Manipulators with protected-models do not have protection against harsh environments. The Controller should be installed in a location that meets its operating environment requirements.

#### KEY POINTS

If the Manipulator will be used in a location that does not meet the above requirements, please contact the supplier.

#### WARNING

- Always use a circuit breaker for the Controller's power supply. Failure to use a circuit breaker may result in an electrical shock hazard or malfunction due to an electrical leakage. Select the correct circuit breaker based on the Controller that you are using. For details, refer to the following manual.

"Robot Controller Manual"

#### CAUTION

- When cleaning the Manipulator, do not rub it strongly with alcohol or benzene. Coated surfaces may lose their luster.

## 2.3.2 Manipulator Mounting Dimensions

### Mounting Area

Also, besides the area required for installation of the Manipulator, Controller, peripheral equipment, and other devices, the following space should be provided at a minimum.

- Space for teaching
- Space for maintenance and inspections (for installing jigs and working safely within the safety barriers)
- Space for cables

### KEY POINTS

- When installing the cables, be sure to maintain sufficient distance from obstacles.
- For the minimum bend radius of the M/C cable, refer to the following section.

#### **CX4 Specifications**

- Also, leave enough space for other cables so that they are not forced to bend at extreme angles.

**Manipulator Mounting Dimensions (CX4 series) [Units: mm]**

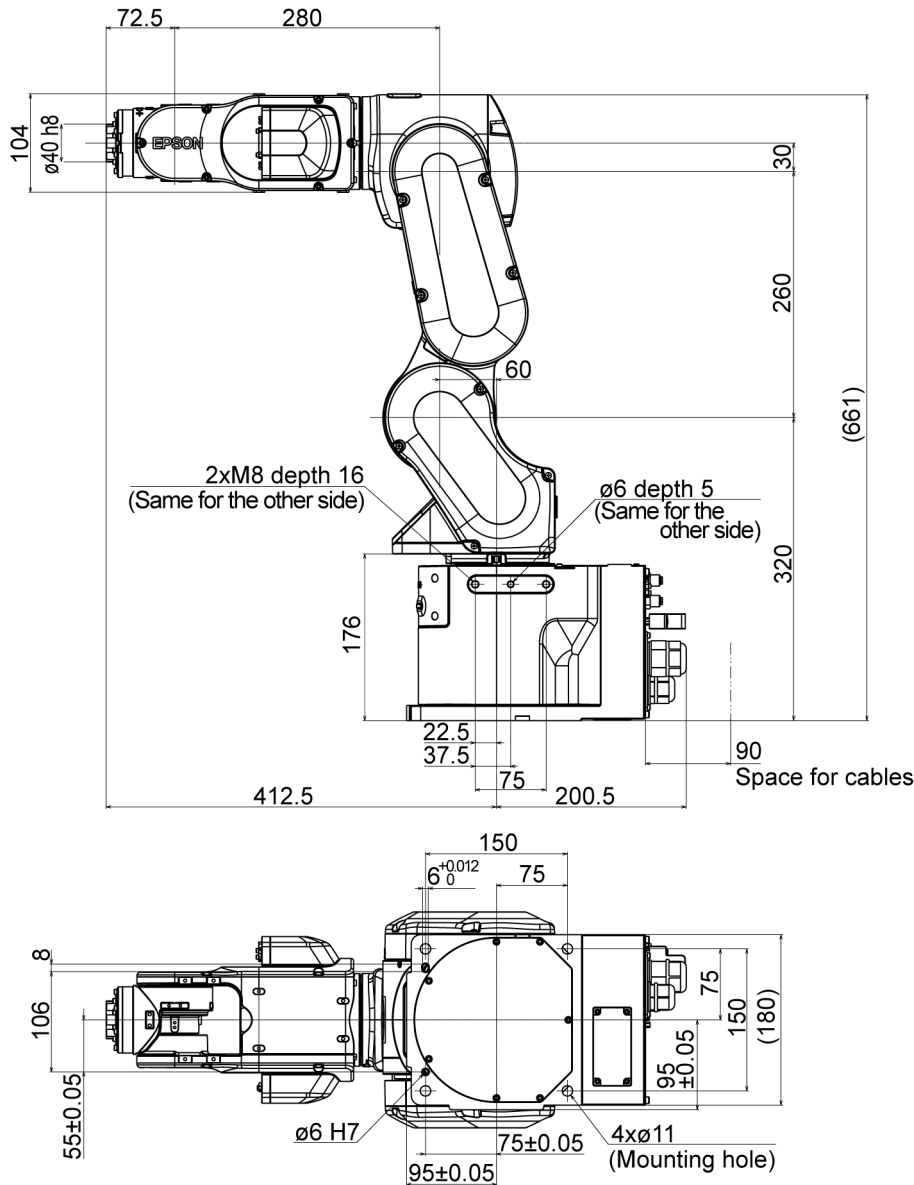

depth = depth of threaded hole

**2.3.3 From Unpacking to Installation**

Transportation and installation of the Manipulator and related equipment should be performed by people who have received installation training provided by Epson and the suppliers. Also, the laws and regulations of the installation country must be followed.

**⚠ WARNING**

- Only qualified personnel should perform sling work and operate a crane or a forklift. When these operations are performed by unqualified personnel, it is extremely hazardous and may result in serious bodily injury and/or severe equipment damage to the robot system
- When hoisting the Manipulator, use your hands to balance it. Losing balance may cause the Manipulator to drop, which is extremely hazardous and may result in serious injury and/or severe damage to the robot system.

- To ensure safety, be sure to install safeguards for the robot system. For more information on safeguards, refer to the following manual.  
"Epson RC+ User's Guide - Safety - Installation and Design Precautions "
- Install the Manipulator in a location with sufficient space so that a tool or a work piece does not touch a wall or a safeguard when the Manipulator extends its arm fully while holding a work piece. If the tool or the workpiece tip reaches a wall or safeguards, it is extremely hazardous and may result in serious bodily injury and/or severe equipment damage to the robot system.
- Be sure to anchor the Manipulator before turning on the power or operating it. Turning on the power or operating the Manipulator while it is not anchored may cause the Manipulator to fall over, which is extremely hazardous and may result in serious injury and/or severe damage to the robot system.
- Before installing or operating the Manipulator, make sure that no parts of the Manipulator are missing and that it has no damage or other external defects. Missing parts or damage may cause malfunction of the Manipulator, is extremely hazardous, and may result in serious injury and/or severe equipment damage to the robot system.

**⚠ CAUTION**

- Use a cart or the like to transport the Manipulator in the same status as it was delivered.
- When removing the fixing bolts securing the Manipulator to the transportation pallet and the packing box or the anchor bolts, support the Manipulator to prevent it falling. Removing the fixing bolts or anchor bolts without supporting the Manipulator may cause it to fall, catching your hands or feet.
- The Manipulator should be transported by two or more people or secured to transporting equipment. Also, do not hold the bottom of the base (the screened parts in the figure). Holding these parts by hand is extremely hazardous and may cause your hands and fingers caught.
  - CX4-A601\*\*\*

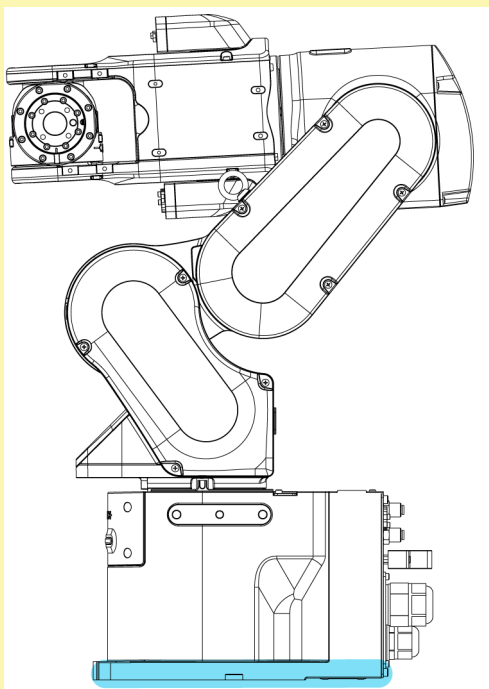

Manipulator weight

	CX4-A601***
Standard (- NIW), cleanroom (- NIW) specifications	30 kg: 66.1 lb

	CX4-A601***
Standard, cleanroom specification, Protected (- NIW) Model	31 kg: 68.3 lb
Protected-Model	32 kg: 70.5 lb

- Take extra care when transporting the Manipulator. You may hit and damage the connector.



- During unpacking and relocation, avoid applying external force to the arms and motors of the Manipulator.
- When transporting the Manipulator over long distances, secure it directly to transporting equipment so that it will not fall. If necessary, pack the Manipulator using the same packaging as delivery.
- The Manipulator must be installed to avoid interference with surrounding buildings, structures, and other machines and equipment that may create a trapping hazard or pinch points.
- Resonance (resonating sound or minute vibrations) may occur during Manipulator operation depending on the rigidity of the base table. If the resonance occurs, improve the rigidity of the base table or change the speed or acceleration and deceleration settings of the Manipulator.

**Protective tape**

Remove the protective tape (4 places).

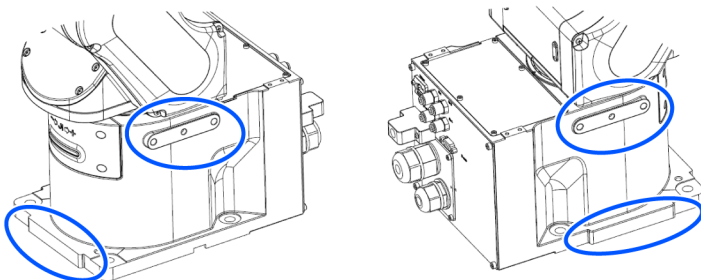

**Fixing bolt**

For details on the dimensions, refer to the following sections.

**Manipulator Mounting Dimensions**

There are four threaded holes for the Manipulator base. Use M8 mounting bolts conforming to the strength equivalent to ISO898-1 property class 10.9 or 12.9.

Tightening torque: 32.0 ± 1.6 N·m (326 ± 16 kgf·cm)

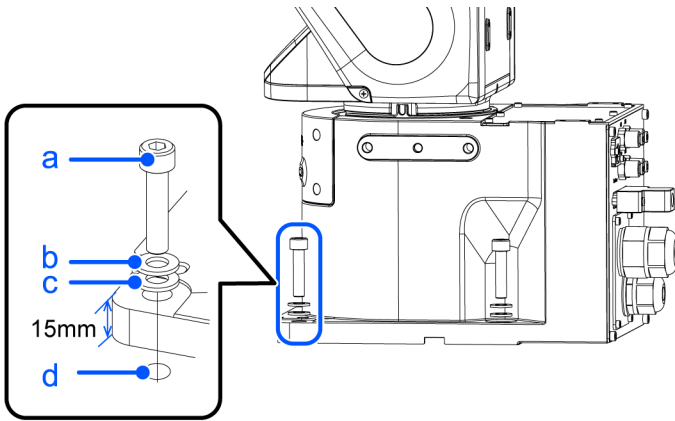

Symbol	Description
a	4×M8×35
b	4×Spring washer
c	4×Plain washer
d	Threaded hole (20 mm or more depth)

**Base table**

A base table for anchoring the Manipulator is not supplied. The base table must be fabricated or obtained by the customer.

The shape and size of the base table vary depending on the application of the robot system. As a reference when designing the base table, the requirements from the Manipulator side are shown here.

The base table must not only be able to bear the weight of the Manipulator but also be able to withstand the dynamic movement of the Manipulator when it operates at maximum acceleration/deceleration. Ensure that there is enough strength on the base table by attaching reinforcing materials such as crossbeams.

Followings are the torque and reaction force produced by the movement of the Manipulator.

	CX4-A601***
Maximum rotating torque on horizontal surface (N·m)	380
Maximum reaction force in horizontal direction (N)	1000
Maximum rotating torque on vertical surface (N·m)	690
Maximum reaction force in vertical direction (N)	1500

**⚠ CAUTION**

If the vibration of the base table is large, reduce the acceleration/deceleration or increase the rigidity of the base table to reduce the vibration. Continued use in a state of large vibration may cause loosening of fastening parts or excessive load on mechanical parts, which may shorten the lifespan.

The plate for the Manipulator mounting face should be at least 30 mm thick and made of steel for reducing vibrations.

A surface roughness of 25 μm or less at the maximum height is appropriate.

The base table must be secured on the floor to prevent it from moving.

The Manipulator installation surface should have a flatness of 0.5 mm or less and an inclination of 0.5° or less. If the installation surface does not have the proper flatness, the base of the Manipulator may be damaged or the robot may be unable to operate at maximum performance.

When using a leveler to adjust the height of the base table, use a screw with M16 diameter or more.

**Connector**

If passing cables through the holes in the base table, refer to the connector dimensions in the figures below. (Units: mm)

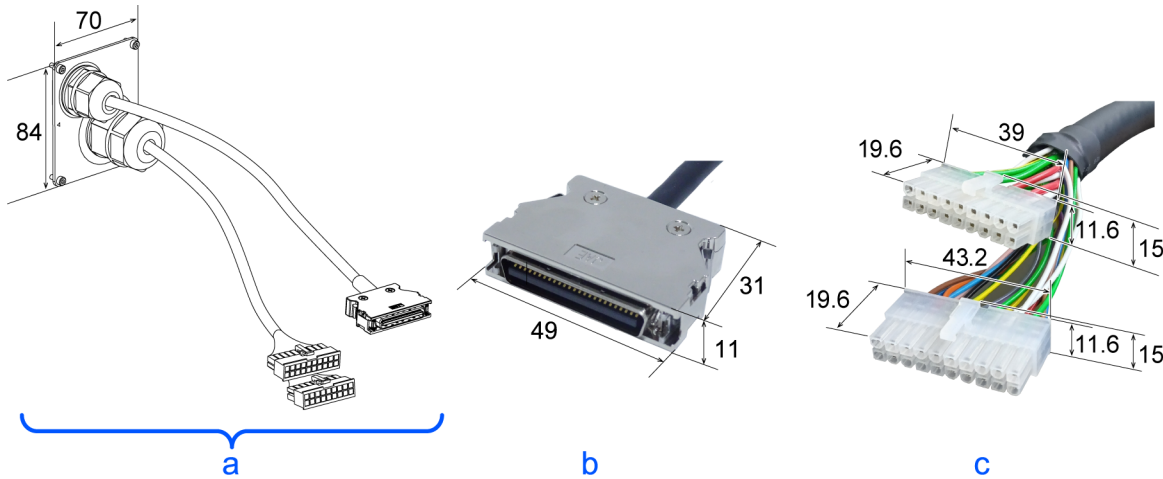

Symbol	Description
a	M/C cable
b	Signal cable connector
c	Power cable connector

Do not remove the M/C cables from the Manipulator.

**KEY POINTS**

For details on the environmental requirements for the space when housing the Controller in the base table, refer to the Robot Controller manual.

When using the Manipulator in the clean room, follow the steps below before the installation.

1. Unpack the Manipulator outside of the cleanroom.
2. Secure the Manipulator to transporting equipment (or a pallet) with bolts so that the Manipulator does not fall down.
3. Wipe off any dust on the Manipulator using a lint-free cloth that was dipped in ethyl alcohol or distilled water.
4. Carry the Manipulator into the cleanroom.
5. Secure the Manipulator to the base table.

**2.3.4 Connecting the Cables**

**WARNING**

- Before performing any replacement work, turn off the Controller and related equipment, and unplug the power cable from the power source. Performing any work procedure with the power turned on is extremely dangerous and may result in electric shock and/or malfunction of the robot system.

- Be sure to connect the AC power cable to a power outlet. Do not connect it directly to a factory power source. To perform the power supply lockout, remove the power plug. Working while connecting the AC power cable to a factory power source may result in electric shock and/or malfunction of the robot system.
- Be sure to connect the cables properly. Do not put heavy objects on the cables, bend or pull on the cables forcibly, or allow the cables to be pinched. Damaged cables, broken wires, or contact failure is extremely hazardous and may result in electric shock and/or malfunction of the robot system.
- Be sure to turn off the power and tag out (e.g., with a "DO NOT TURN ON" sign) before performing wiring. Performing any work procedure with the power turned on is extremely dangerous and may result in electric shock and/or malfunction of the robot system.
- The Manipulator is grounded by connecting it to the Controller. Ensure that the Controller is grounded and the cables are correctly connected. If the ground wire is improperly connected to ground, it may result in the fire or electric shock.
- Turn off the power to the Robot Controller and brake release unit when connecting or replacing the brake release unit or external short connector. Inserting or removing connectors with the power on may result in electric shock and/or malfunction of the robot system.

### CAUTION

- When connecting the Manipulator and the Controller, check that the serial numbers match for each device. Improper connection between the Manipulator and the Controller may not only lead to malfunction of the robot system but also safety problems. The connection method between the Manipulator and the Controller varies depending on the Controller. For details on the connection, refer to the following manual.  
"Robot Controller Manual"
- Only authorized or certified personnel should perform wiring. Wiring by unauthorized or uncertified staff may result in bodily injury and/or malfunction of the robot system.
- Operating the Manipulator without a brake release unit or external short connector connected may cause the brake to fail to release, possibly damaging the brake.  
After using the brake release unit, be sure to connect the external short circuit connector to the Manipulator or make sure to leave the connector for the brake release unit connected.

### **Cleanroom-model Manipulator**

When the Manipulator is a model with cleanroom specifications, an exhaust system must be connected. For the exhaust system, refer to the following section.

#### **[CX4 Specifications](#)**

### **Connection procedure for M/C cable**

Connect the power connector and signal connector of the M/C cable to the Controller.

If the Manipulator is the type of model that does not have an M/C cable, you will need to connect the M/C cable.

### 2.3.4.1 How to Connect the Manipulator and M/C Cable

1. Loosen two of the M4 hexagon socket head cap bolts.  
The bolts cannot be removed.

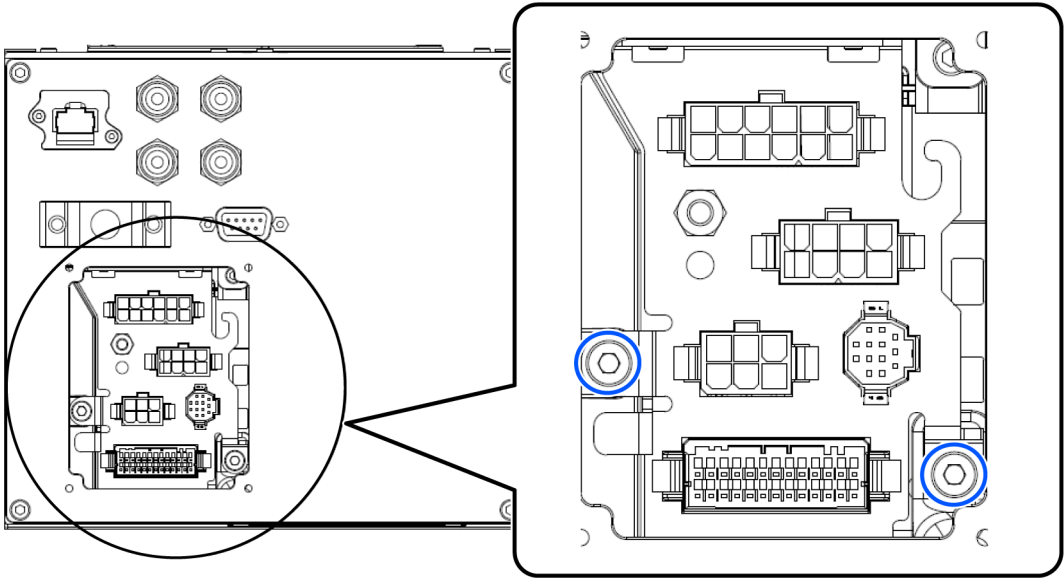

2. Pull the pull rod towards you and slide it to the left.

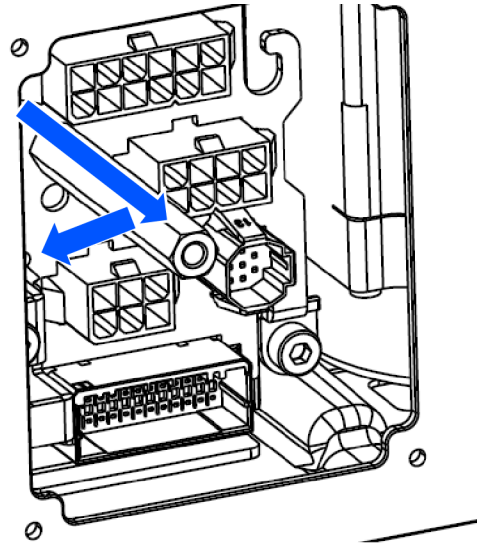

3. Connect the connector and the M/C cable at five locations so that the orientation of the sheet metal aligns with the symbol.

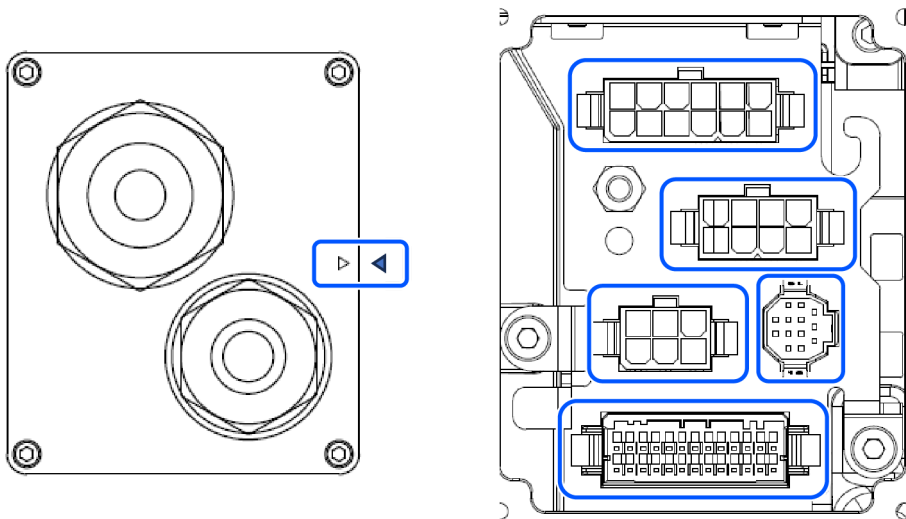

4. Slide the pull rod to the right and push it in.

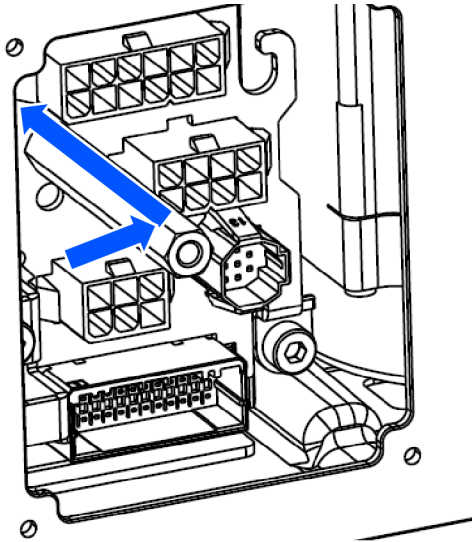

5. Secure two of the M4 hexagon socket head cap bolts.

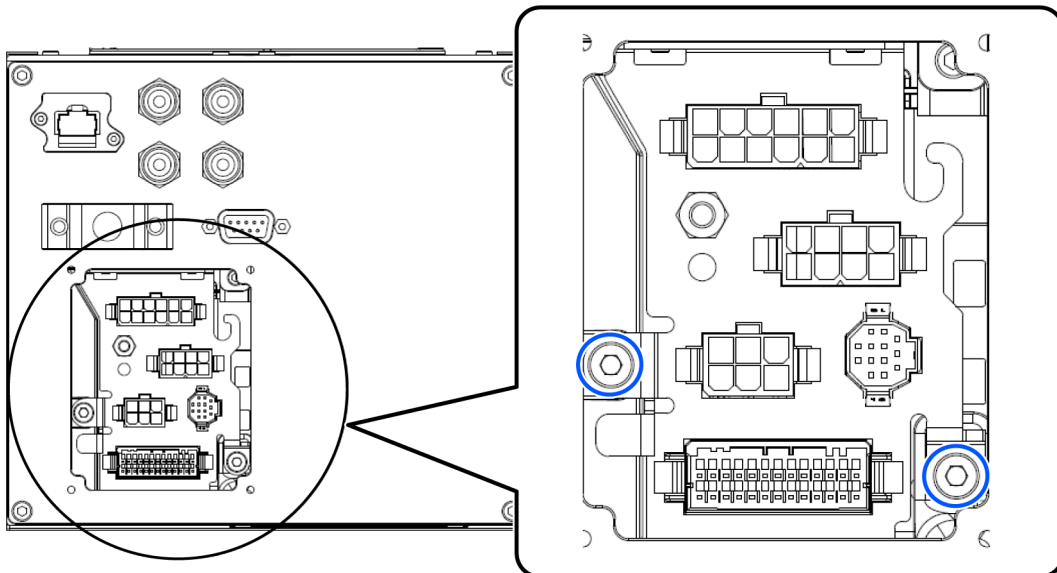

- Tightening Torque:  $2.0 \pm 0.2 \text{ N}\cdot\text{m}$

### KEY POINTS

Be careful not to tighten the screw while the cable is pinched.

6. Arrange the following based on the environmental specifications:

**For Standard and Cleanroom model:**

Adjust so that the mark align, secure four of the M3 hexagon socket head cap bolts.

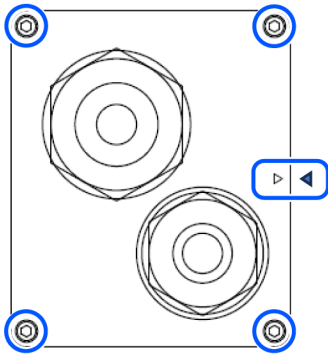

- Tightening Torque:  $2.0 \pm 0.1 \text{ N}\cdot\text{m}$

**KEY POINTS**

Be careful not to tighten the screw while the cable is pinched.

**For Protected-Models:**

Fit the spacer into the packing seal.

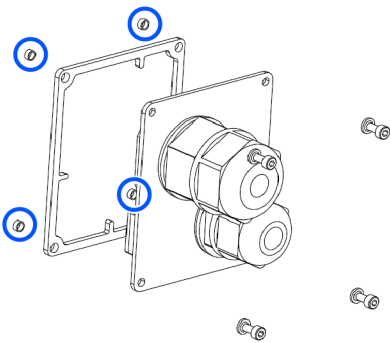

Adjust so that the mark align, insert the seal washer, and secure it with four M3 hexagon socket head cap bolt.

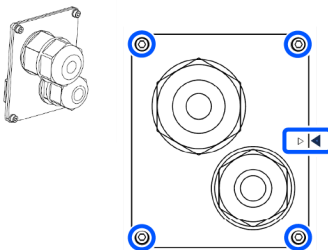

- Tightening Torque:  $2.0 \pm 0.1 \text{ N}\cdot\text{m}$

**KEY POINTS**

Be careful not to tighten the screw while the cable is pinched.

**2.3.4.2 M/C Cable and Controller Connection**

Connect the power connector and signal connector of the M/C cable to the Controller.



Symbol	Description
a	Signal connector
b	Power connector

There are two types of M/C cables: One for fixing and the other for movable use. Cables for movable use has lines as shown in the figure below.



### 2.3.5 User Wires and Pneumatic Tubes

**⚠ CAUTION**

- Only authorized or certified personnel should perform wiring. Wiring by unauthorized or uncertified staff may result in bodily injury and/or malfunction of the robot system.

User electrical wires and pneumatic tubes are contained in the cable unit.

**Electrical Wires**

Rated Voltage	Allowable Current	Wires	Note
AC/DC30V	1 A	9	Shielded

		Manufacturer	Type
9 pin	Connector	JAE	DE-9PF-N (Solder type)
	Clamp hood	JAE	DE-C8-J9-F2-1R (Connector setscrew: # 4- 40 NC)

Pins with the same number, indicated on the connectors on both ends of the cables, are connected.

**Pneumatic Tubes**

Maximum Working Pressure	Number of Tubes	Outer Diameter × Inner Diameter
0.59 MPa (6 kgf/cm <sup>2</sup> : 86 psi)	4	ø4 mm×ø2.5 mm

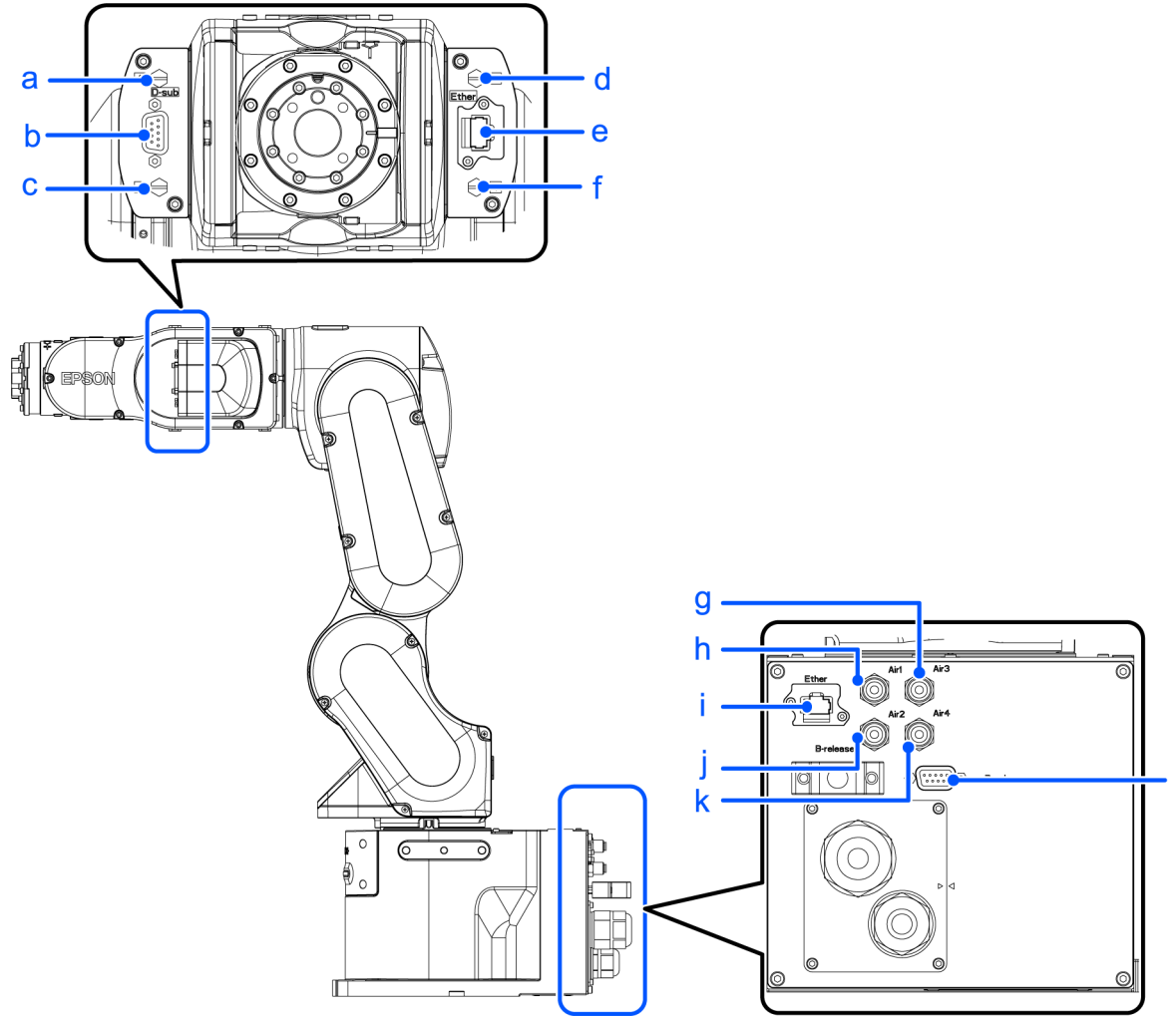

Tubes with the same number are connected.

Symbol	Description
a	No.1
b	User cable connector (9-pin D-sub connector)
c	No.2
d	No.3
e	Ethernet cable connector

Symbol	Description
f	No.4
g	Fitting for ø4 mm tube (Air3)
h	Fitting for ø4 mm tube (Air1)
i	Ethernet cable connector
j	Fitting for ø4 mm tube (Air2)
k	Fitting for ø4 mm tube (Air4)
l	User cable connector (9-pin D-sub connector)

## 2.3.6 Checking the Basic Orientation

After installing the Manipulator and setup the operating environment, check if it moves to the basic position properly.

Follow the steps below to set the basic orientation of the Manipulator shown below as the origin position.

1. Start Epson RC+.  
Double click the [Epson RC+] icon on the desktop.
2. Open the command window.  
Epson RC+ menu-[Tools]-[Command Window]
3. Execute the following command in [Command Window].

```
>Motor On
>Go Pulse (0,0,0,0,0,0)
```

### KEY POINTS

If "Error 4505: cannot be turned on the motor because the Safety Board is issuing a stop signal." occurs, use one of the following methods to move the Manipulator to its basic orientation.

- Release the brake and push the arm by hand to move it within the motion range. Then follow the steps above. For details on releasing brake, refer to the following section.  
[How to Move Arms with the Electromagnetic Brake](#)
- Press the TP3 or TP4 command button [Pulse0] to move the Manipulator to its basic orientation. For details, refer to the following manual.  
For TP3:  
"Robot Controller Option Teach Pendant TP3 Operation 3.1.3 Command Buttons"  
For TP4:  
"Robot Controller Option Teach Pendant TP4 3.2.5.13.2 Command Buttons"  
"Robot Controller Option Teach Pendant TP4 3.2.9.7.2 Command Buttons"

If the Manipulator cannot be in the basic orientation shown below, please contact the supplier.

### Basic orientation (0 pulse position)

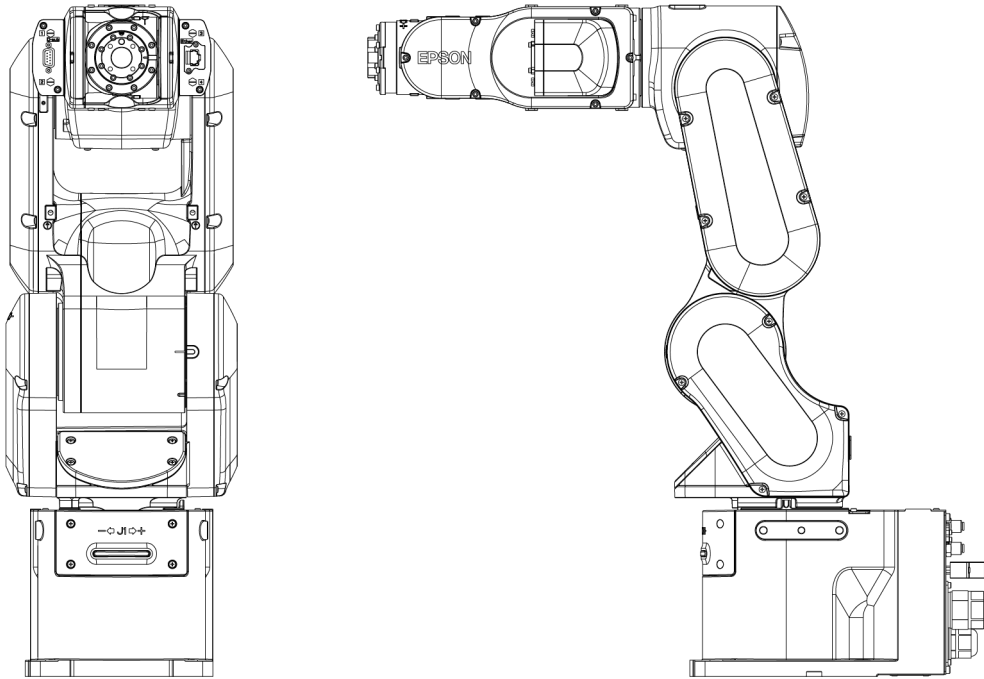

## 2.3.7 Relocation and Storage

### 2.3.7.1 Safety Information for Relocation and Storage

Pay attention to the following requirements when relocating, storing, and transporting the Manipulators.

Transportation and installation of the Manipulator and related equipment should be performed by people who have received installation training provided by Epson and the suppliers. Also, the laws and regulations of the installation country must be followed.

#### **⚠ WARNING**

- Only qualified personnel should perform sling work and operate a crane or a forklift. When these operations are performed by unqualified personnel, it is extremely hazardous and may result in serious bodily injury and/or severe equipment damage to the robot system

#### **⚠ CAUTION**

- Before relocating, fold the arm and secure it tightly with a cable tie to prevent hands or fingers from getting caught in the Manipulator.
- When removing the anchor bolts, support the Manipulator so that it does not fall. Removing the anchor bolts without supporting the Manipulator can cause it to fall, causing hands or feet to get caught.
- The Manipulator should be transported by two or more people or secured to transporting equipment. Also, do not hold the bottom of the base. Holding these parts by hand is extremely hazardous and may cause your hands and fingers caught.

During unpacking and relocation, avoid applying external force to the arms and motors of the Manipulator.

When transporting the Manipulator over long distances, secure it directly to transporting equipment so that it will not fall. If necessary, pack the Manipulator using the same packaging as delivery.

When the Manipulator is reassembled and used for a robot system again after an extended period of storage, perform a test run to verify that it works properly before starting the main operation.

Manipulators should be transported and stored under the following conditions: Temperature: -20 to +60°C, Humidity: 10 to 90% (no condensation)

If condensation has formed on the Manipulator during transportation or storage, do not turn on the power until the condensation is removed.

Do not subject the Manipulator to excessive impacts or vibrations during the transportation process.

**Relocation**

Follow the procedures described below when relocating the Manipulator.

1. Turn off the power for all devices and unplug the power cable connector and signal cable connector from the Controller. Do not remove the M/C cables (power cable and signal cable) from the Manipulator.

 **KEY POINTS**

Remove the mechanical stops if using them to limit the motion range. For details on the motion range, refer to the following section.

**Setting the Work Envelope by Mechanical Stops**

2. Unscrew the anchor bolts. Then, remove the Manipulator from the base table.
3. Position the Manipulator as shown in the figure. Then, secure the Manipulator to the transporting equipment or have at least two people to relocate the Manipulator.  
(Recommended: Joint #2 +55°, Joint #3 -58°, Joint #4+90°, Joint #5 -90°)  
Do not hold the bottom of the base (the screened parts in the figure). Holding these parts by hand is extremely hazardous and may cause your hands and fingers caught.

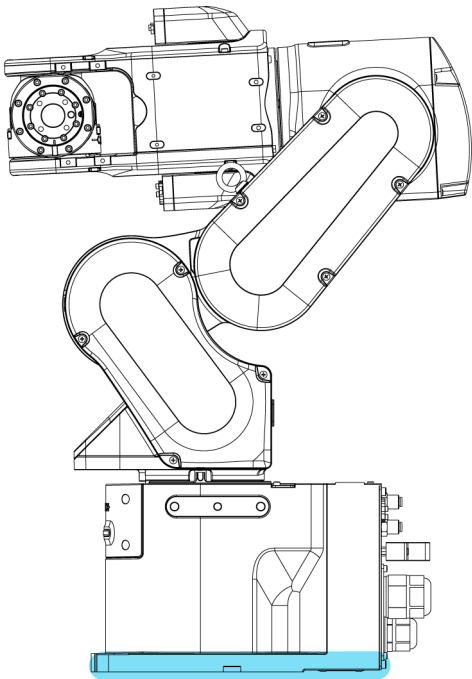

Manipulator weight

	CX4-A601***
Standard (- NIW), cleanroom (- NIW) specifications	30 kg: 66.1 lb

	CX4-A601***
Standard, cleanroom specification, Protected (- NIW) Model	31 kg: 68.3 lb
Protected-Model	32 kg: 70.5 lb

**Using eyebolts**

Check that the eyebolts are securely fastened before transporting the Manipulator. After transporting the Manipulator, remove the eyebolts and keep them for future use.

The eyebolts (accessory, 2 pcs) and wire must be strong enough to withstand the weight (See the figures below).

If you use the eyebolts to lift up the Manipulator, make sure to put hands on it to keep the balance. The Manipulator may fall if the balance is lost and this is extremely hazardous.

To prevent damage on the covers and arms, it is recommended to protect the contacting parts of the wire and arm with a cloth. Be very careful not to damage the covers since they are made of plastic.

**Lifting load**

	CX4-A601***
Standard (- NIW), cleanroom (- NIW) specifications	29 kg: 63.9 lb
Standard, cleanroom specification	33 kg: 72.8 lb
Protected-Model	33 kg: 72.8 lb

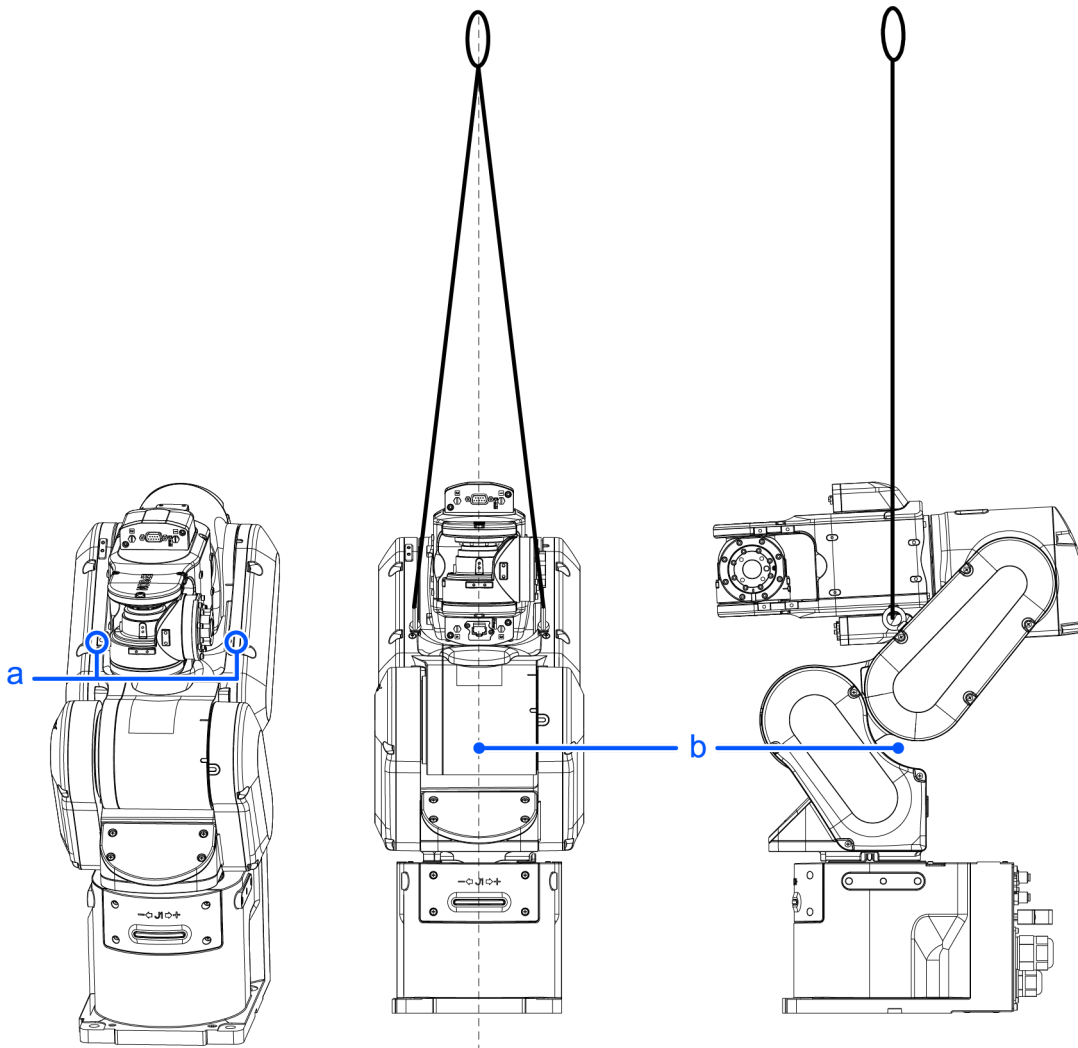

(deg. = °)

Symbol	Description
a	Threaded holes for eyebolts: 2×M6 depth 13
b	Center of gravity

\* Use the wire of 1000 mm or longer to avoid contact with Manipulator.

Take extra care if you use the shorter wire to lift the Manipulator, because the wire is likely to touch Arm #4 or the side cover and break the Manipulator.

### CAUTION

- Remove the eyebolts from the Manipulator after transportation/relocation is completed.  
If the Manipulator is operated with the eyebolts left on it, the arm may collide with the eyebolts and it may cause equipment damage to and/or malfunction of the Manipulator.

## 2.4 Setting the Hand

### 2.4.1 Installing the Hand

The hand (end effector) must be prepared by the customer. For details on attaching the hand, refer to the following manual. "Hand Function Manual"

Flange dimensions of the wrist attached to the end of Arm #6 is as below.

**⚠ WARNING**

- Before attaching a hand or peripheral equipment, be sure to always turn off the Controller and related equipment and unplug the power cables. Performing any work procedure with the power turned on is extremely dangerous and may result in electric shock and/or malfunction of the robot system.

**⚠ CAUTION**

- When the hand is equipped with a workpiece gripping mechanism, ensure that the wiring and pneumatic tubes do not cause the hand to release the workpiece when the power is turned off. When the wiring and pneumatic tubes are not designed for the hand to maintain its grip on the workpiece when the power is turned off, pressing the emergency stop switch releases the workpiece, which may damage the robot system and the workpiece.

By default, all I/Os are designed to automatically turn off (0) when the power is shut off, when an emergency stop is triggered, or by the robot system's safety function.

However, I/Os set with the Hand function does not turn off (0) when executing the Reset statement, or when performing an emergency stop.

For the risk of the residual air pressure, conduct a risk assessment on the equipment and take the necessary protective measures.

**Wrist flange**

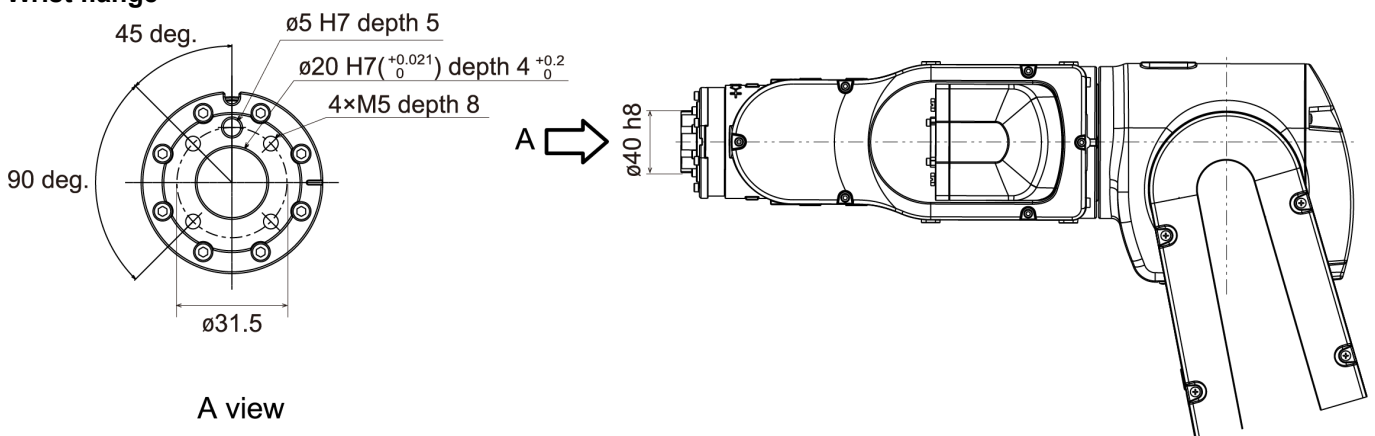

\* Applicable area

**Arm #6**

Attach the hand to the end of the Arm #6 using the M5 bolts.

**Layout**

When attaching and operating a hand, the hand may come into contact with the Manipulator body due to the outer diameter of

the hand, the size of the workpiece, or the position of the arm. Carefully consider the interference area of the hand when designing the system layout.

## 2.4.2 Attaching Cameras and Valves

Decks are equipped to Arms #3 and #5 to enable the easy installation of air valve. If the payload exceeds the maximum payload, refer to the following section.

**"WEIGHT Setting** - Restrictions on payload exceeding the maximum payload"

To mount the camera, the camera plate unit is necessary. We provide the optional Camera Plate Unit. For details, refer to the following section.

### Options

(Units: mm)

#### CX4-A601\*\*\*

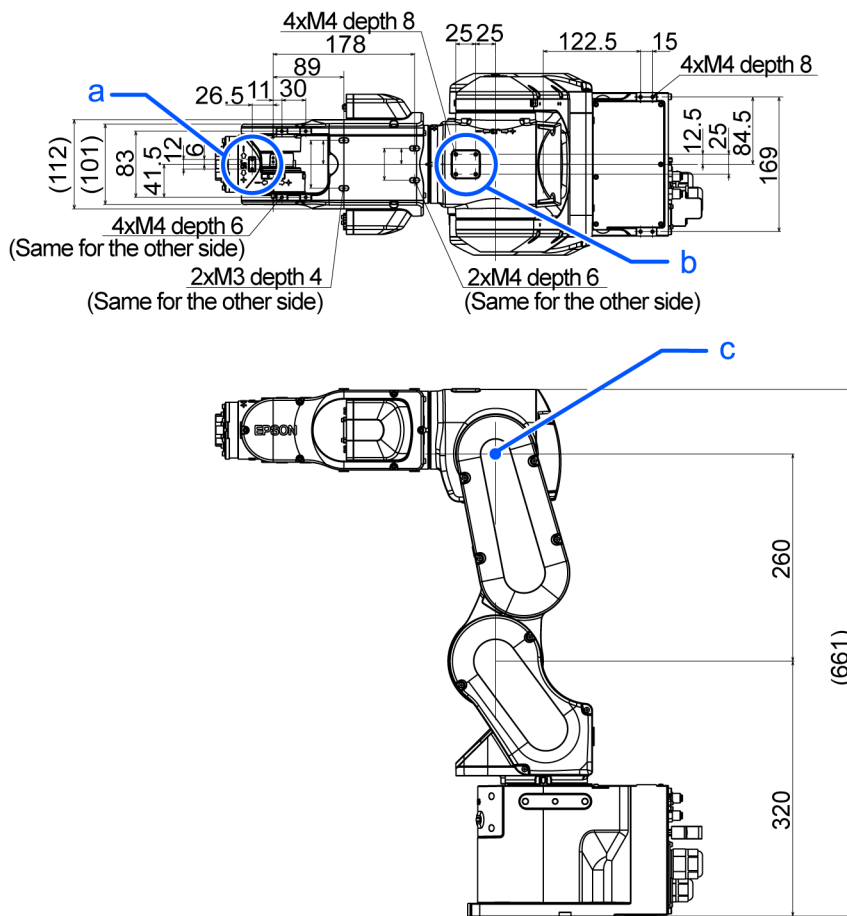

Symbol	Description
a	Arm #5 Deck
b	Arm #3 Deck
c	Rotation center of the upper arm

## 2.4.3 WEIGHT and INERTIA Settings

The WEIGHT and INERTIA commands are for setting the load parameters of the Manipulator. These settings optimize the Manipulator motion.

- **WEIGHT Setting**

The WEIGHT command is for setting the load weight. The more the load weight increases, the more the speed and acceleration/deceleration are reduced.

- **INERTIA Setting**

The INERTIA command is for setting the inertia moment and the eccentricity of the load. The more the inertia moment increases, the more the acceleration and deceleration of the Arm #6 are reduced. The more the eccentricity increases, the more the acceleration and deceleration for the Manipulator movement are reduced.

To ensure that the Manipulator is functioning properly, keep the load (the sum of the weights of the hand and workpiece) and the moment of inertia of the load within the rated values, and do not allow for eccentricity from the center of the Arm #6. If the load or the inertia moment exceeds the ratings or if the load becomes eccentric, follow the steps below to set parameters.

- **WEIGHT Setting**
- **INERTIA Setting**

Setting parameters makes the operation of the Manipulator optimal, reduces vibration to shorten the operating time, and improves the capacity for larger loads. This also works to curb any persistent vibration that may occur when the hand and workpiece have a large moment of inertia.

You can also perform settings using the "Weight, Inertia, and Eccentricity/Offset Measurement Utility."

For details, refer to the following manual.

"Epson RC+ User's Guide - Weight, Inertia, and Eccentricity/Offset Measurement Utility"

The allowable load for CX4 series Manipulators is up to 4 (5) kg\*.

Due to the limitations of the moment and moment of inertia shown in the table below, the load (hand + workpiece) should also meet these conditions.

If force is applied to the Manipulator instead of weight, it should not exceed the values shown in the table below.

\* If the payload exceeds the maximum payload, refer to the following section.

"**WEIGHT Setting** - Restrictions on payload exceeding the maximum payload"

### Allowable Load

Joint	Allowable moment	Allowable moment of inertia ( $GD^2/4$ )
Joint #4	8.86 N·m	0.20 kg·m <sup>2</sup>
Joint #5 *	8.86 N·m	0.20 kg·m <sup>2</sup>
Joint #6	4.90 N·m	0.10 kg·m <sup>2</sup>

### Moment

The moment indicates amount of torque applied on the joint in order to support the gravity on the load hand + workpiece). The moment increases as weight of the load and amount of eccentricity increase. As this also increases the load applied on the joint, make sure to keep the moment within the allowable value.

A maximum torque (T) is calculated by the following formula.

$$T = m \text{ (kg)} \times L \text{ (m)} \times g \text{ (m/s}^2\text{)}$$

- m: Weight of load (kg)
- L: Eccentricity of load (m)
- g: Gravitational acceleration (m/s<sup>2</sup>)

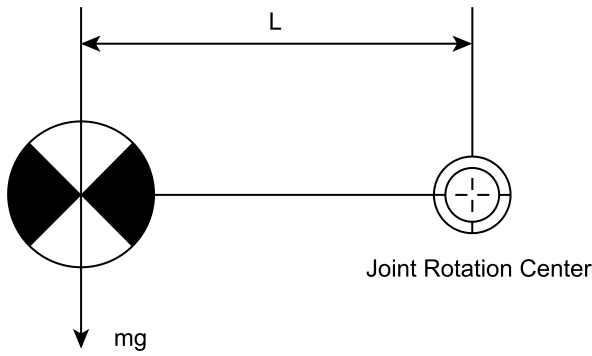

The figure below shows distribution of the center of gravity when the volume of the load (hand + workpiece) is small. Design the hand so that the center of gravity is within the allowable moment.

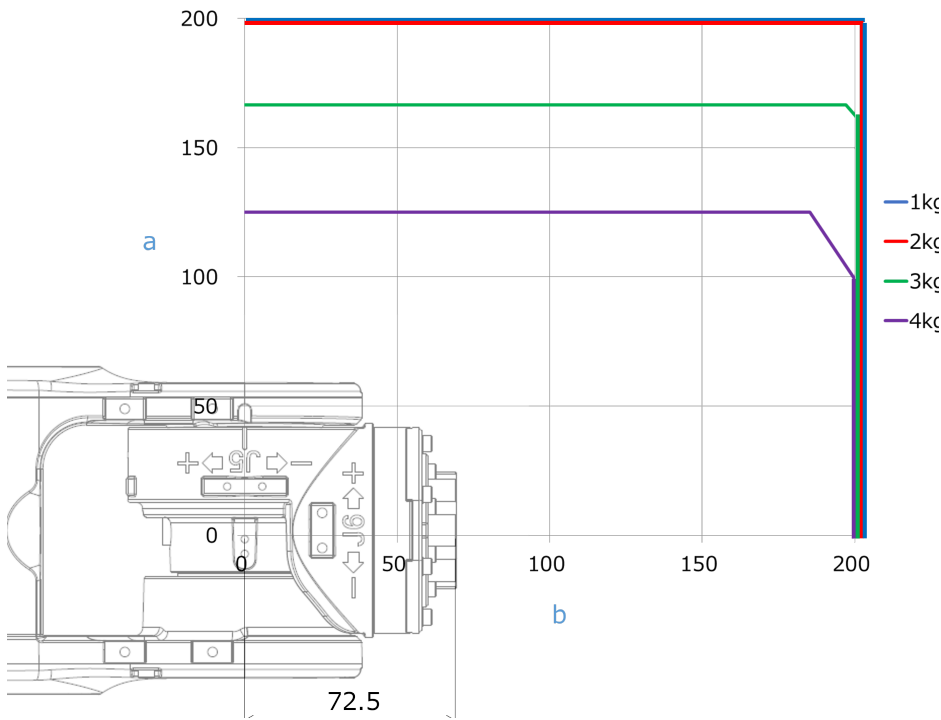

Symbol	Description
a	Distance from the center of Arm #* rotation [mm]
b	Center of gravity of load from the Arm #* rotation center [mm]

**Max. Eccentricity of Load (Distance between the joint rotation center and the load’s center of gravity)**

Axis	WEIGHT 1 kg	WEIGHT 2 kg	WEIGHT 3 kg	WEIGHT 4 kg
#4	200 mm	200 mm	200 mm	200 mm
#5	200 mm	200 mm	200 mm	200 mm
#6	200 mm	200 mm	167 mm	125 mm

(The maximum eccentricity of load is restricted to 200 mm or less.)

When calculating the critical dimension of the load using the allowable moment and inertia moment, the calculated value represents a distance from the Arm #6 rotation center, not the distance from the flange. To calculate the distance from the flange to the load’s center of gravity, subtract the distance from the center of the Arm #5 rotation center to the flange (=72.5 mm) as shown in the example below.

Example: Calculate the critical dimension of the load on the Arm #5 (A) when a 2.5 kg load is on the Arm #6 rotation center line (B = 0)

Center of gravity by the allowable moment control:  $8.86 \text{ N}\cdot\text{m}/(2.5 \text{ kg} \times 9.81 \text{ m/s}^2) = 0.36 \text{ m} = 360 \text{ mm}$

Compared to the graph, the center of gravity for the load limit will be 200 mm.

Distance from the flange to the center of gravity for the load limit  $A = 200 \text{ mm} - 72.5 \text{ mm} = 127.5 \text{ mm}$

**Critical Dimension of Load**

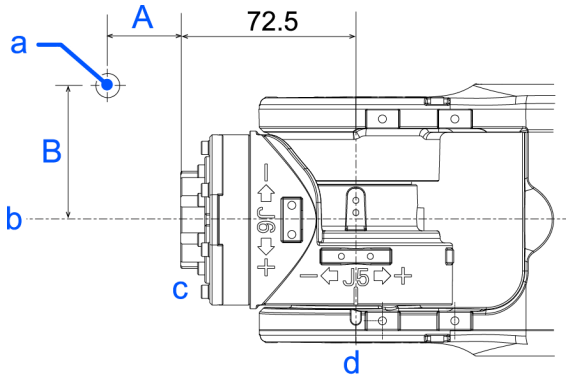

(Units: mm)

Symbol	Description
a	Load center of gravity position
b	Arm #6 rotation center
c	Flange
d	Arm #5 rotation center

**2.4.3.1 WEIGHT Setting**

**⚠ CAUTION**

- Set the total weight of the hand and the workpiece smaller than the maximum payload.  
 The CX4 Manipulators can operate without limitations on the condition unless and until the load exceeds this maximum payload. When the payload of the Manipulator exceeds the maximum payload, refer to the section "Restrictions on payload exceeding the maximum payload" in the later part of this section for details.  
 Always set the Weight parameters of the WEIGHT command according to the load. Setting a value smaller than the actual weight may cause errors or impact that not only impair full functionality but also shorten the life of the mechanical components.

The acceptable weight capacity (hand + workpiece) for CX4 Manipulators is as follows:

Rated	Maximum
1 kg	4 (5) kg*

When the load exceeds the rating, change the setting of the weight parameter. After changing the Weight parameter setting, the maximum acceleration/deceleration and speed of the robot system corresponding to the load is set automatically.

\* If the payload exceeds the maximum payload, refer to the following section.  
**"WEIGHT Setting - Restrictions on payload exceeding the maximum payload"**

**Setting method of Weight parameters**



Select [Tools]-[Robot Manager]-[Weight] panel and set the value in [Weight:]. You may also execute the Weight command from [Command Window].

**Load on the Manipulator**

Mounting location of the load

**CX4-A601\*\*\***

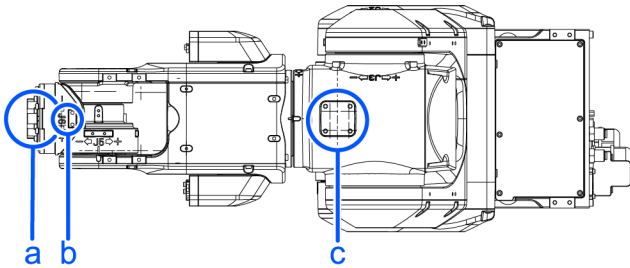

Symbol	Description
a	Load on the fore end of Arm #6
b	Arm #5 deck
c	Arm #3 deck

**CX4 series**

Deck detailed

(Units: mm)

Arm #5 deck	Arm #3 deck

When you attach the equipment to the decks on the upper arm, convert its weight into equivalent weight assuming that the equipment is attached to the end of the Arm #6. Then, this equivalent weight added to the load will be a Weight parameter.

Calculate the Weight parameter by using the formula below and enter the value.

**Weight Parameter Formula**

$$\text{Weight Parameter} = M_w + W_a + W_b$$

- $M_w$ : Payload on the fore end of Arm #6 (kg)
- $W_a$ : Equivalent weight of the Arm #3 deck (kg)
- $W_b$ : Equivalent weight of the Arm #5 deck (kg)
- $W_a = M_a (L_a)^2 / (L)^2$

- $W_b = M_b (L_b)^2 / (L)^2$
- $M_a$ : Weight of the air valve on the Arm #3 deck (kg)
- $M_b$ : Weight of the camera on the Arm #5 deck (kg)
- $L$ : Length of the upper arm (352.5 mm)
- $L_a$ : Distance between the Joint #3 and the center of gravity of the air valve on the Arm #3 deck (mm)
- $L_b$ : Distance between the Joint #3 and the center of gravity of the camera on the Arm #5 deck (mm)

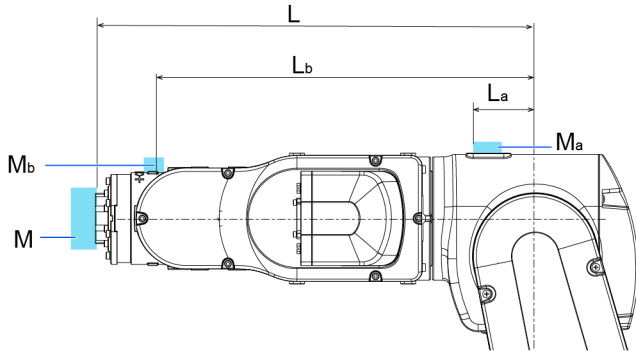

[Example]

When the following loads apply to CX4 which fore end of the Arm #6 is 352.5 mm (L) away from the Joint #3 and payload ( $M_w$ ) is 1 kg:

- Load on the Arm #3 deck is 1.5 kg ( $M_a$ ). The deck is 0 mm ( $L_a$ ) away from the Joint #3.
- Load on the Arm #5 deck is 0.5 kg ( $M_b$ ). The deck is 280 mm ( $L_b$ ) away from the Joint #3.

$$W_a = 1.5 \times 0^2 / 352.5^2 = 0$$

$$W_b = 0.5 \times 280^2 / 352.5^2 = 0.315 \rightarrow 0.4 \text{ (round up)}$$

$$M_w + W_a + W_b = 1 + 0 + 0.4 = 1.4$$

Enter "1.4" for the Weight parameter.

**Automatic speed setting by Weight parameter**

The percentages on the graph are ratios based on 100% as the [Maximum operating speed] of CX4 specifications.

**CX4-A601\*\*\***

Standard mode

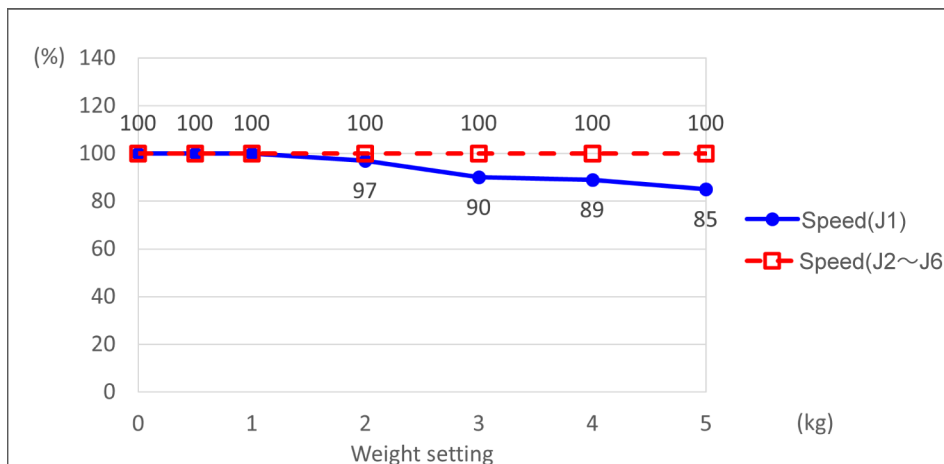

Boost mode

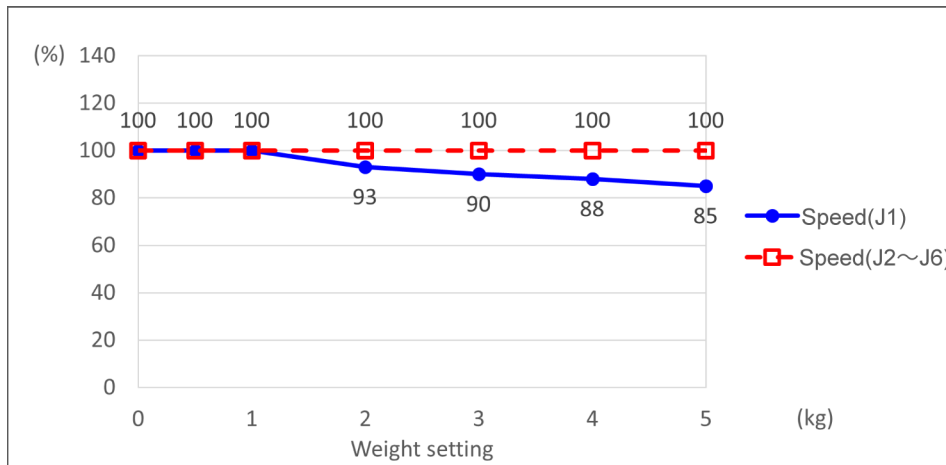

Automatic speed setting by Weight parameter

The percentages on the graph are ratios based on 100% as the acceleration/deceleration at the rated (1 kg) setting for each of the standard and boost mode.

For details on the automatic acceleration/deceleration setting of J6, refer to the following:

[INERTIA Setting](#)

CX4-A601\*\*\*

Standard mode

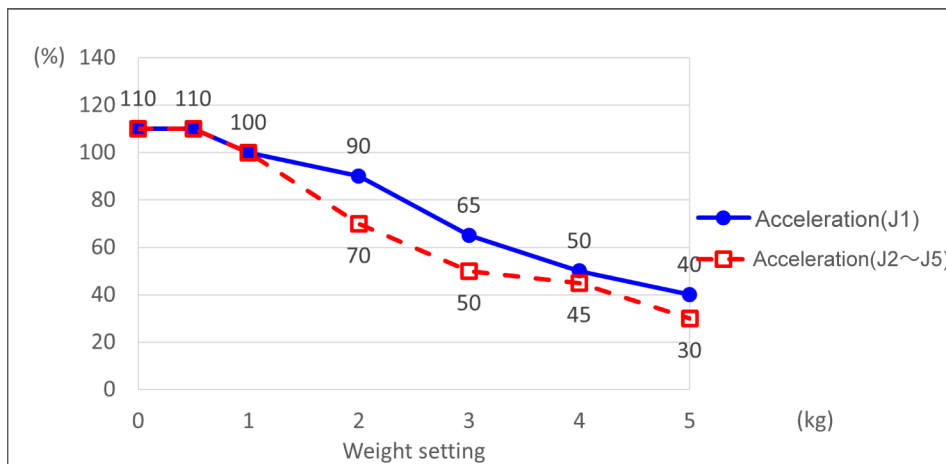

Boost mode

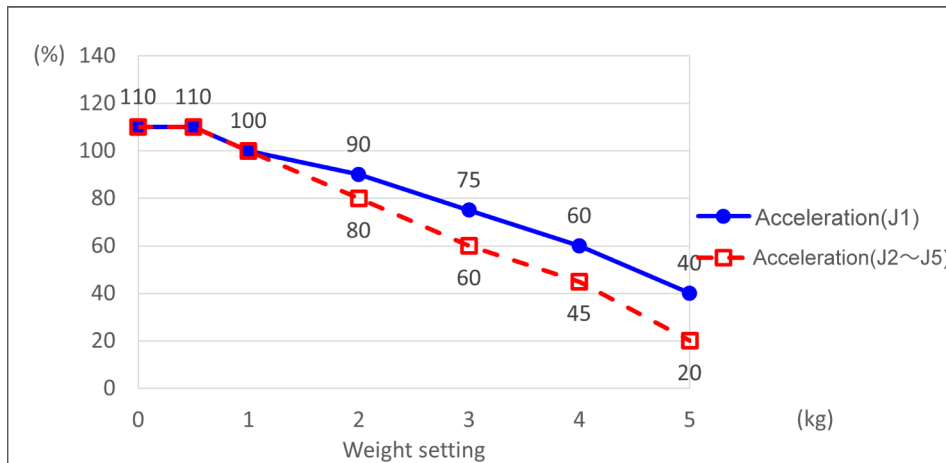

- If the payload exceeds the maximum payload, refer to the following section.  
["WEIGHT Setting - Restrictions on payload exceeding the maximum payload"](#)

**Restrictions on payload exceeding the maximum payload**

Maximum payload for CX4 Manipulators is as follows: Payload can be increased by restricting the arm posture of the Arm #5 downward.

Max. Payload	Max. Payload with Pose Restriction
4 kg	5 kg

If the load exceeds the maximum payload, use the Arm #5 with a posture angle within the range indicated in the following graph.

The graph shows the relation of the load weight and Arm #5 angle limit (A1) measured in vertical direction (direction of gravity). Note that the heavier the load on the Arm #6, the smaller the angle limit becomes.

When the Manipulator operates vertically to the operating surface, the limit of the Arm #5 is equivalent to the limit of the operating angle (A2).

In addition, for the eccentric load, the angle limit is an angle of the line joining the center of the load and the Arm #5 rotation axis with the vertical direction (B).

The eccentricity of the load should be within the allowable moment and moment of inertia of Arms #4, #5, and #6.

**Relation of load weight and Arm #5 angle limit**

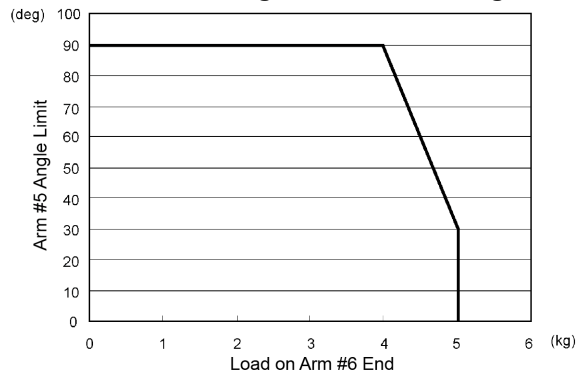

**Relation of Arm #5 angle and operating surface**

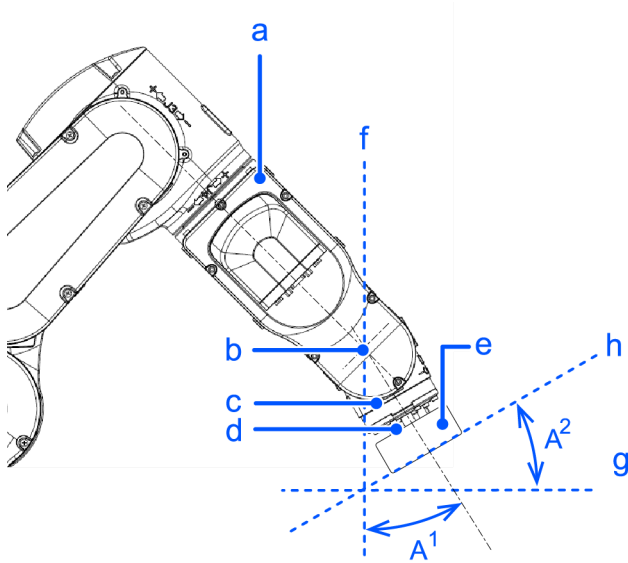

Symbol	Description
a	Arm #4

Symbol	Description
b	Arm #5 rotation axis
c	Arm #5
d	Arm #6
e	Load on the fore end of Arm #6
f	Vertical direction
g	Plane
h	Operating surface

Angle limit for eccentric load

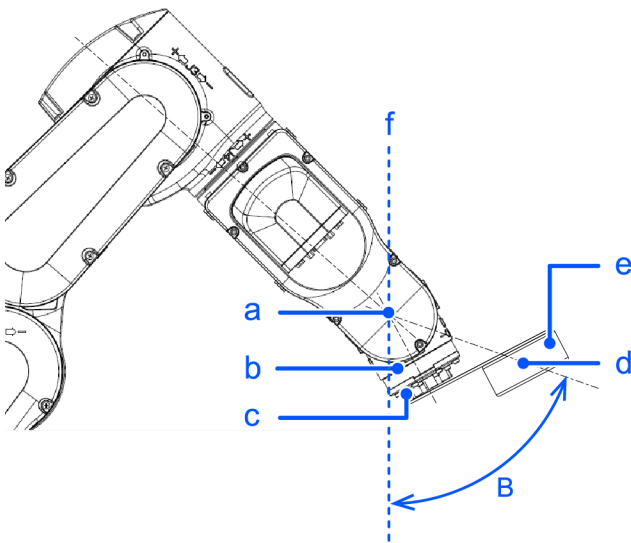

Symbol	Description
a	Arm #5 rotation axis
b	Arm #5
c	Arm #6
d	Center of gravity
e	Load on the fore end of Arm #6
f	Vertical direction

### 2.4.3.2 INERTIA Setting

#### Moment of Inertia and INERTIA Setting

The moment of inertia is a quantity that expresses how hard it is for an object to turn, and it is expressed in terms of values for the moment of inertia, inertia, or  $GD^2$ . When a hand or other object is attached to the Arm #6 for operation, the moment of inertia of the load must be taken into consideration.

#### ⚠ CAUTION

- The moment of inertia of the load (hand + workpiece) must be  $0.1 \text{ kg}\cdot\text{m}^2$  or less.

The CX4 Manipulators are not designed to work with a moment of inertia exceeding  $0.1 \cdot \text{m}^2$ . Always set the value corresponding to the moment of inertia. Setting a parameter value that is smaller than the actual moment of inertia may cause errors or impact, may prevent the Manipulator from working at full functionality, and may shorten the lifespan of mechanical parts.

The allowable moment of inertia of a load for CX4 Manipulators is  $0.005 \cdot \text{m}^2$  at the default rating and  $0.1 \text{ kg} \cdot \text{m}^2$  at the maximum. When the moment of inertia of the load exceeds the rating, change the setting of the moment of inertia parameter for the load in the Inertia statement. After the setting is changed, the maximum acceleration/deceleration of Arm #6 that corresponds to the "Inertia" value is corrected automatically.

**Moment of Inertia of Load Attached to Arm #6**

The moment of inertia of the load (hand + workpiece) attached to the Arm #6 can be set by the "Inertia" parameter in the Inertia statement.

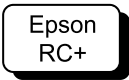

Go to [Tools] - [Robot Manager] - [Inertia] panel, and enter the value in [Inertia]. This can also be set using the Inertia statement in [Command Window].

**Eccentricity and INERTIA Setting**

**⚠ CAUTION**

- The eccentricity of the load (hand + workpiece) must be 200 mm or less. The CX4 Manipulators are not designed to work with eccentricities exceeding 200 mm. Always set the value based on the eccentricity. Setting the eccentricity parameter to a value smaller than the actual eccentricity may cause errors or impact that not only impair full functionality but also shorten the life of the mechanical components.

The allowable eccentricity of load for CX4 Manipulators is 30 mm at the default rating and 200 mm at the maximum. When the load eccentricity exceeds the rating, change the setting for the eccentricity parameter in Inertia statement. After the setting is changed, the maximum acceleration/deceleration of the Manipulator that corresponds to the "Eccentricity" is corrected automatically.

Eccentricity

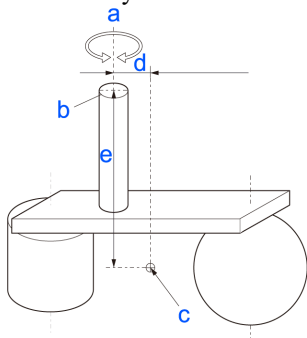

Symbol	Description
a	Rotation axis
b	Flange
c	Load center of gravity position

Symbol	Description
d, e	Eccentricity (200 mm or less) To set the parameter, enter the larger value of "d" or "e".

**Eccentricity of Load Attached to Arm #6**

The eccentricity of the load (hand + workpiece) attached to the Arm #6 can be set by the "Eccentricity" parameter in the Inertia statement.

Enter the larger value of either "d" or "e" in the figure above to [Eccentricity].

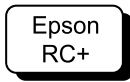

Go to [Tools] - [Robot Manager] - [Inertia] panel, and enter the value in [Eccentricity]. This can also be set using the Inertia statement in [Command Window].

**Automatic Acceleration/Deceleration Correction at INERTIA (Moment of inertia) Setting**

The percentages on the graph are ratios based on 100% as the acceleration/deceleration at the rated (0.005 kg·m<sup>2</sup>) setting. Correction for both the standard and boost mode are the same.

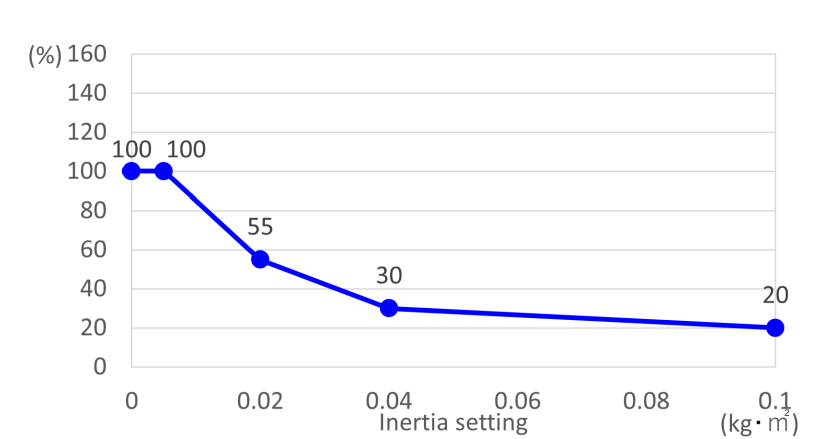

**Automatic Acceleration/Deceleration Correction at INERTIA (Eccentricity) Setting**

The percentages on the graph are ratios based on 100% as the acceleration/deceleration at the rated (30 mm) setting. The eccentricity correction varies depending on the WEIGHT setting. Correction for both the standard and boost mode are the same.

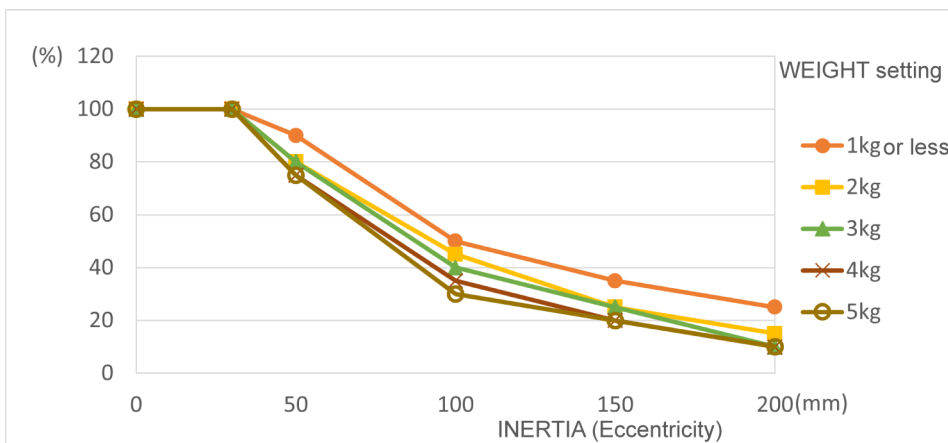

**Calculating the Moment of Inertia**

An example of calculating the moment of inertia of a load (hand holding a workpiece) is shown below.

The moment of inertia of the entire load is calculated by the sum of (A), (B), and (C).

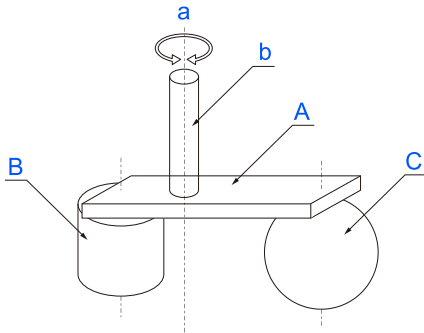

$$\text{Whole moment of inertia} = \text{Moment of inertia of end effector (A)} + \text{Moment of inertia of work piece (B)} + \text{Moment of inertia of work piece (C)}$$

Symbol	Description
a	Rotation axis
b	Shaft
A	Hand
B	Workpiece
C	Workpiece

The methods for calculating the moment of inertia for (A), (B), and (C) are shown below. Use the moment of inertia of these basic shapes as a reference to find the moment of inertia of the entire load.

**(A) Moment of inertia of a rectangular parallelepiped**

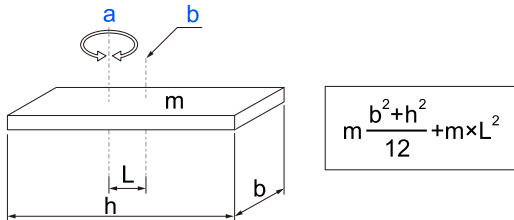

Symbol	Description
a	Rotation axis
b	Center of gravity of rectangular parallelepiped
m	Weight

**(B) Moment of inertia of a cylinder**

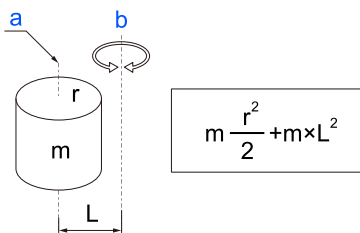

Symbol	Description
a	Center of gravity of cylinder

Symbol	Description
b	Rotation axis
m	Weight

**(C) Moment of inertia of a sphere**

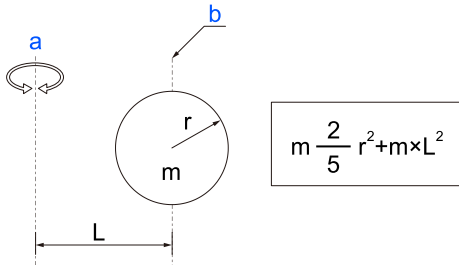

Symbol	Description
a	Rotation axis
b	Center of gravity of sphere
m	Weight

**2.4.4 Safety Information for Auto Acceleration**

The speed and acceleration/deceleration of the Manipulator motion are automatically optimized according to the values of WEIGHT and INERTIA and the Manipulator’s postures.

**WEIGHT Setting**

The speed and acceleration/deceleration of the Manipulator are controlled according to the load weight set by the WEIGHT command. The more the load weight increases, the more the speed and acceleration/deceleration are reduced to prevent residual vibration.

**INERTIA Setting**

The acceleration/deceleration of Arm #6 are controlled according to the inertia moment set by the INERTIA command. The acceleration/deceleration of the whole Manipulator are controlled according to the eccentricity set by the INERTIA command. The more the inertia moment and eccentricity of the load increase, the more the acceleration/ deceleration are reduced.

**Auto Acceleration/Deceleration According to Manipulator’s Posture**

The acceleration/deceleration are controlled according to the Manipulator’s posture. When the Manipulator extends its arms or when the movement of the Manipulator produces vibration frequently, the acceleration/deceleration are reduced.

Set appropriate values for WEIGHT and INERTIA so that the Manipulator operation is optimized.

## 2.5 Work Envelope

**⚠ CAUTION**

When restricting the work envelope for safety reasons, be sure to make settings using both the pulse range and mechanical stop.

The work envelope is preset at the factory as explained in the following section. This is the maximum work envelope of the Manipulator.

### Standard Work Envelope

The work envelope can be set by one of the following three methods.

1. Setting by pulse range (for each joint)
2. Setting by mechanical stops
3. Setting the Rectangular Range in the XY Coordinate System of the Manipulator

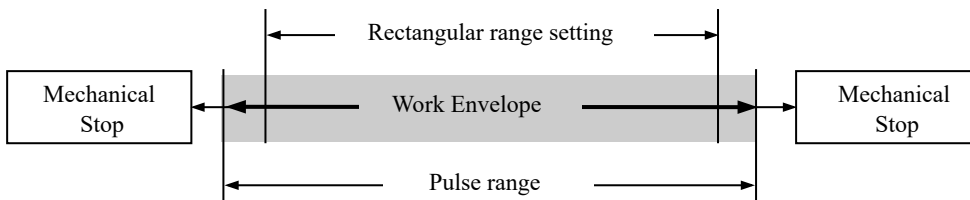

To limit the work envelope for layout efficiency or safety reasons, make the settings as explained in the following sections.

- [Work Envelope Setting by Pulse Range \(for Each Joint\)](#)
- [Setting the Work Envelope by Mechanical Stops](#)
- [Restriction of Manipulator Operation by Joint Angle Combination](#)
- [Coordinate System](#)

### 2.5.1 Work Envelope Setting by Pulse Range (for Each Joint)

Pulses are the basic unit of Manipulator motion. The motion range (work envelope) of the Manipulator is set by the pulse lower limit value and pulse upper limit value (pulse range) for each joint. Pulse values are read from the encoder output of the servomotor.

Be sure to set the pulse range within the mechanical stop range.

**✎ KEY POINTS**

Once the Manipulator receives a motion command, it checks whether the target position specified by the command is within the pulse range before operating. If the target position is outside of the pulse range that was set, an error occurs and the Manipulator does not move.



Go to [Tools] - [Robot Manager] - [Range] panel, and make the setting. This can also be set using the Range statement in [Command Window].

### 2.5.1.1 J1 Maximum Pulse Range

With the 0 pulse as a starting point, the counterclockwise pulse value is defined as positive (+), and the clockwise pulse value is defined as negative (-).

#### CX4-A601\*\*\*

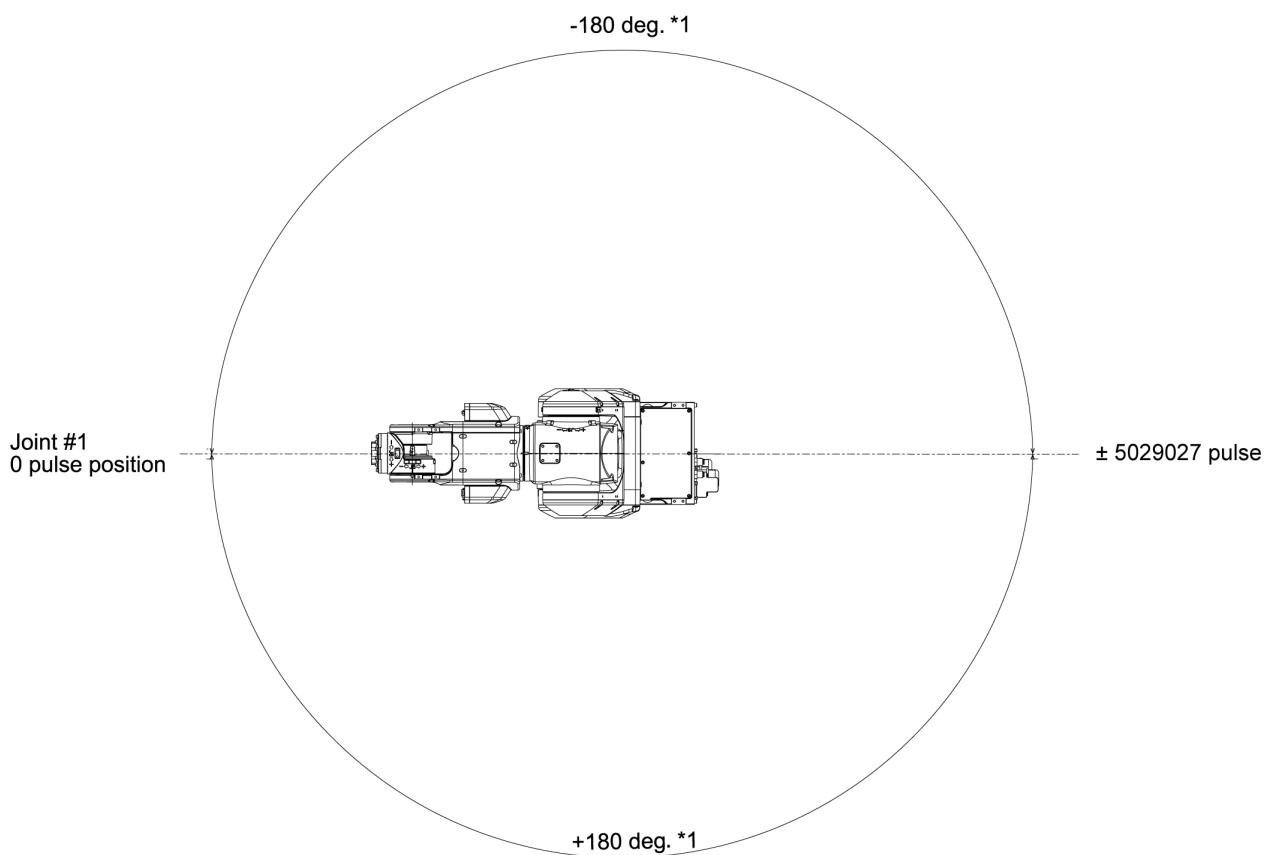

\*1 Software limit maximum value

### 2.5.1.2 J2 Maximum Pulse Range

With the 0 pulse as a starting point, the clockwise pulse value is defined as positive (+), and the counterclockwise pulse value is defined as negative (-).

#### CX4-A601\*\*\*

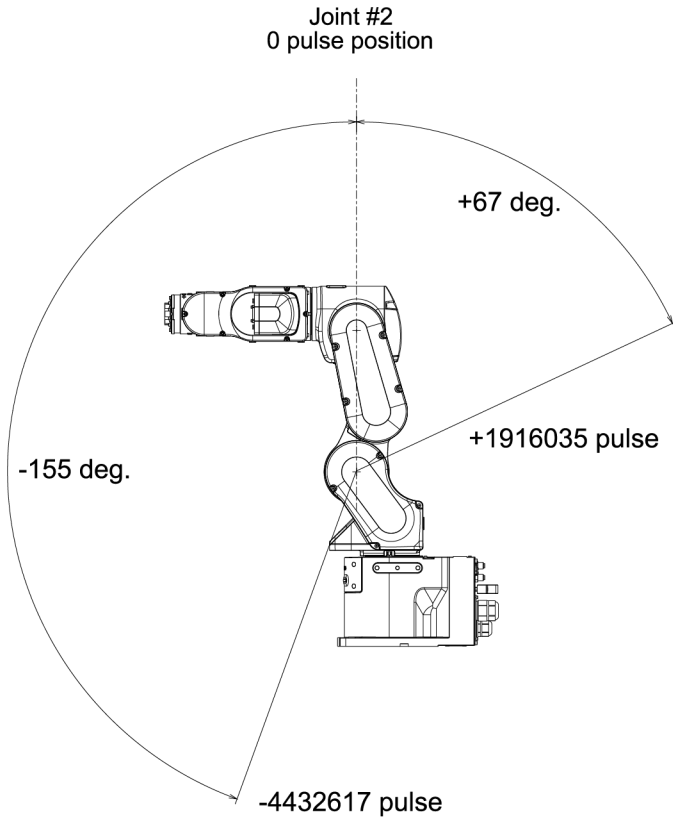

### 2.5.1.3 J3 Maximum Pulse Range

With the 0 pulse as a starting point, the clockwise pulse value is defined as positive (+), and the counterclockwise pulse value is defined as negative (-).

**CX4-A601\*\*\***

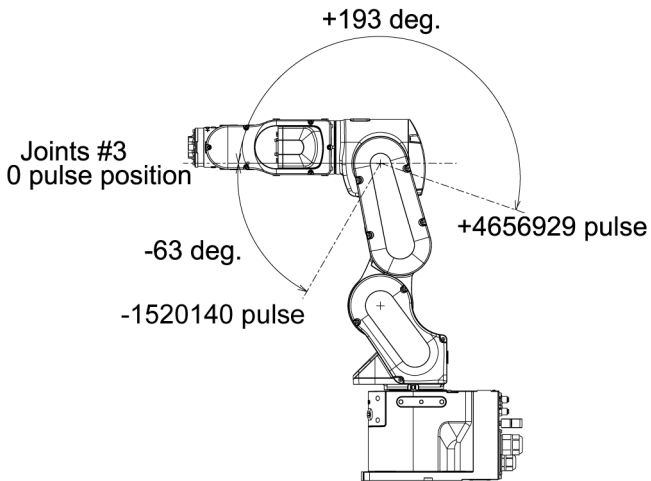

### 2.5.1.4 J4 Maximum Pulse Range

From the angle of arm end, with the 0 pulse as a starting point, the clockwise pulse value is defined as positive (+), and the counterclockwise pulse value is defined as negative (-).

**CX4-A601\*\*\***

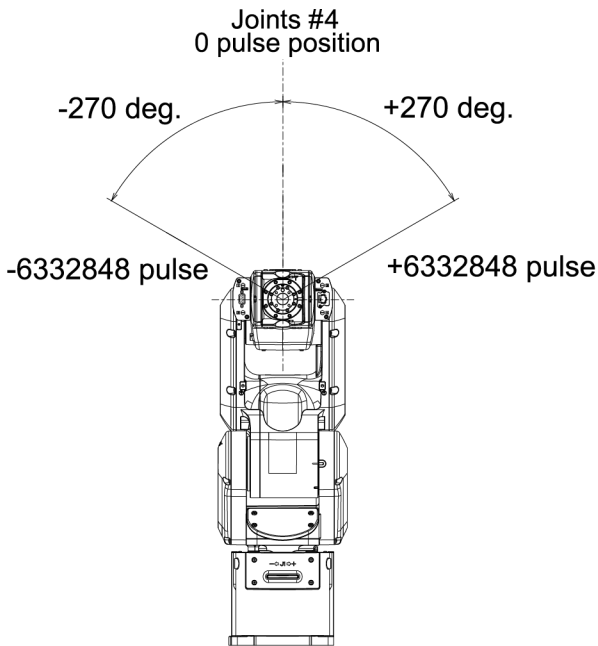

**CAUTION**

- Do not set and/or use the J4 with a pulse range exceeding the maximum value. The J4 does not have a mechanical stop. Using the J4 with a pulse range exceeding the maximum pulse range may cause the inner wiring damaged and/or malfunction to the Manipulator.

**2.5.1.5 J5 Maximum Pulse Range**

With the 0 pulse as a starting point, the clockwise pulse value is defined as positive (+), and the counterclockwise pulse value is defined as negative (-).

**CX4-A601\*\*\***

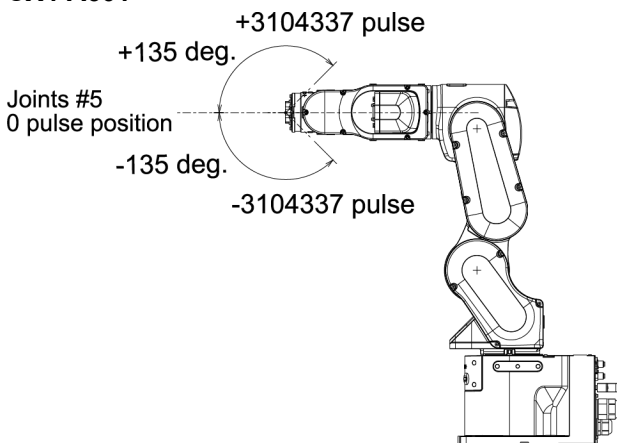

**2.5.1.6 J6 Maximum Pulse Range**

From the angle of arm end, with the 0 pulse as a starting point, the clockwise pulse value is defined as positive (+), and the counterclockwise pulse value is defined as negative (-).

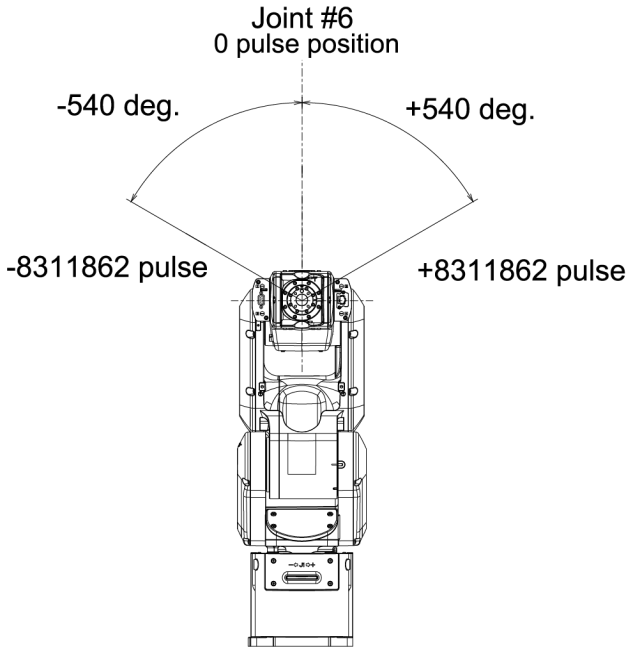
**CX4-A601\*\*\***

## 2.5.2 Setting the Work Envelope by Mechanical Stops

Mechanical stops set the absolute work envelope that physically limits where the Manipulator can move.

Before starting any work, be sure to turn off the Controller.

Use bolts conforming to the specified length and surface processing (ex: nickel plating) with high corrosion resistance.

Specify the pulse range again after changing the position of the mechanical stop.

For details on the pulse range setting, refer to the following section.

### [Work Envelope Setting by Pulse Range \(for Each Joint\)](#)

Be sure to set the pulse range inside the positions of the mechanical stop range.

### 2.5.2.1 Setting the Arm #1 Work Envelope

Install variable mechanical stop (J1) in the threaded holes corresponding to the angles to be set.

Normally a mechanical stop is not equipped.

- Hexagon socket head cap bolt: M10×15
- Strength: Compliant with ISO 898-1 property class: 10.9 or 12.9
- Tightening torque: 58.0 N·m (591 kgf·cm)

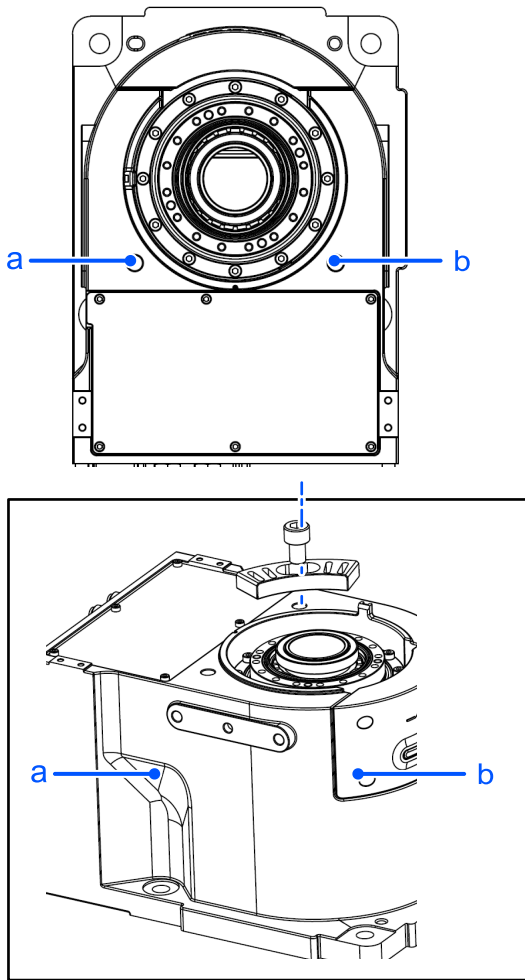

	a	b
Angle (°)	±145	-45 ,(+180)
Pulse	-3640889, +4951609	±4660338
Variable Mechanical Stop (J1)	Applied	Applied

### 2.5.3 Restriction of Manipulator Operation by Joint Angle Combination

To prevent the arms of the Manipulator from interfering each other, the Manipulator operation is restricted in the specified motion range according to the angle combination of the Joint #1, #2, and #3.

The Manipulator operation is restricted and the Manipulator stops when the joint angles are within the colored areas in the following figure.

**The restriction to Manipulator operation is enabled:**

- During CP motion command execution
- When you attempt to execute the motion command for moving the Manipulator to a target point (or pose) in the specified motion range.

**The restriction to the Manipulator operation is disabled:**

- The Arms of the Manipulator momentarily go through the specified motion range during the PTP motion command execution even though the joint angles of the Arms are in the colored areas of the figures above.

**Combination of Joint #1 and #2 (CX4-A601\*\*\*)**

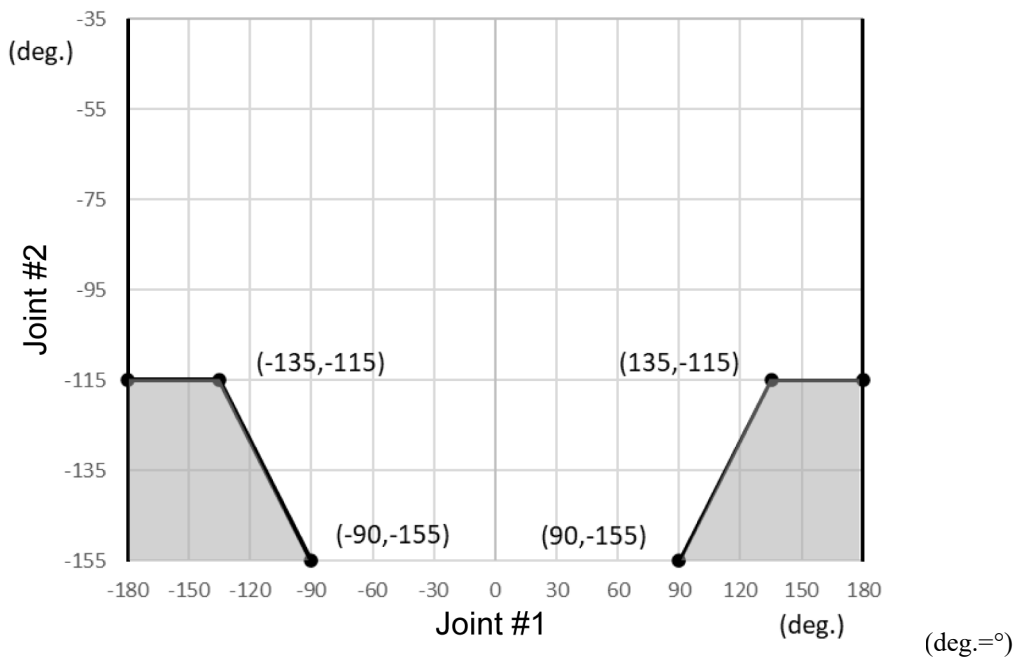

**Combination of Joint #2 and #3 (CX4-A601\*\*\*)**

- -135 deg. <= J1 <= 135 deg.

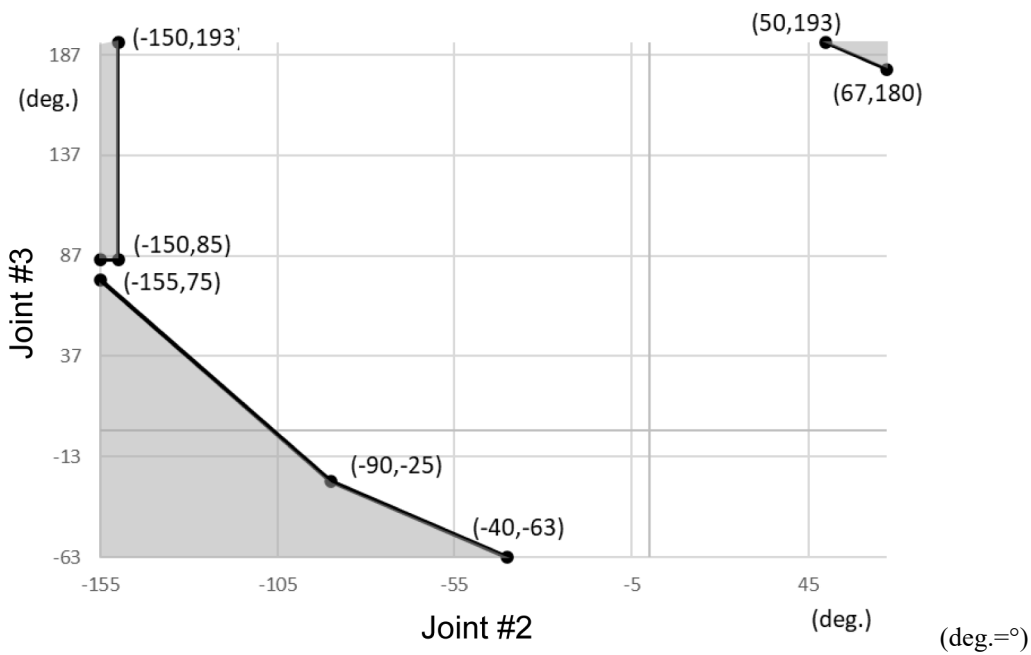

- -180 deg. <= J1 < -135 deg. or 135 deg. < J1 <= 180 deg.

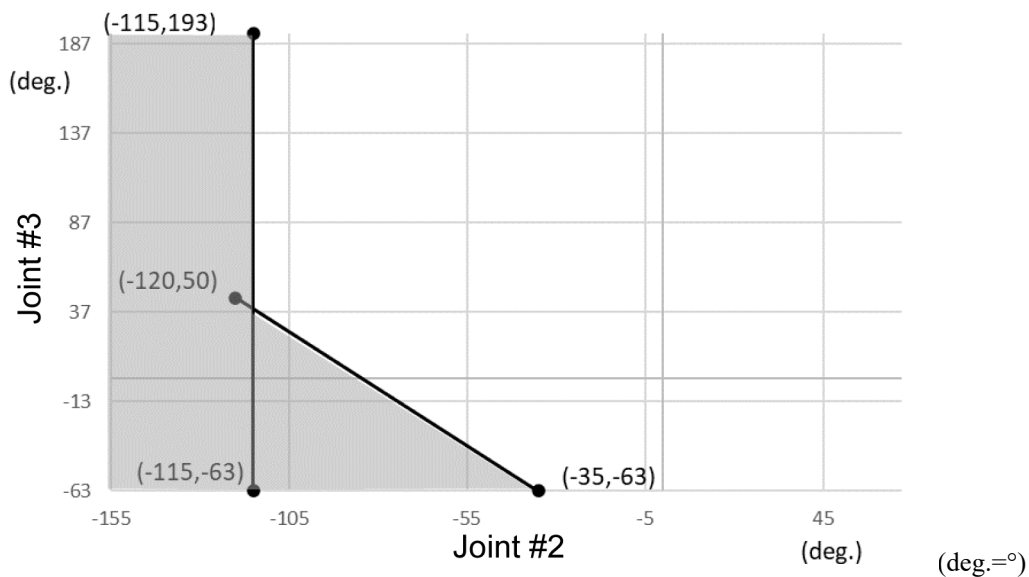

### 2.5.4 Coordinate System

The origin point is where the Manipulator’s installation face intersects with the rotation axis of Joint #1.

For details on the coordinate system, refer to the Epson RC+ Users Guide manual.

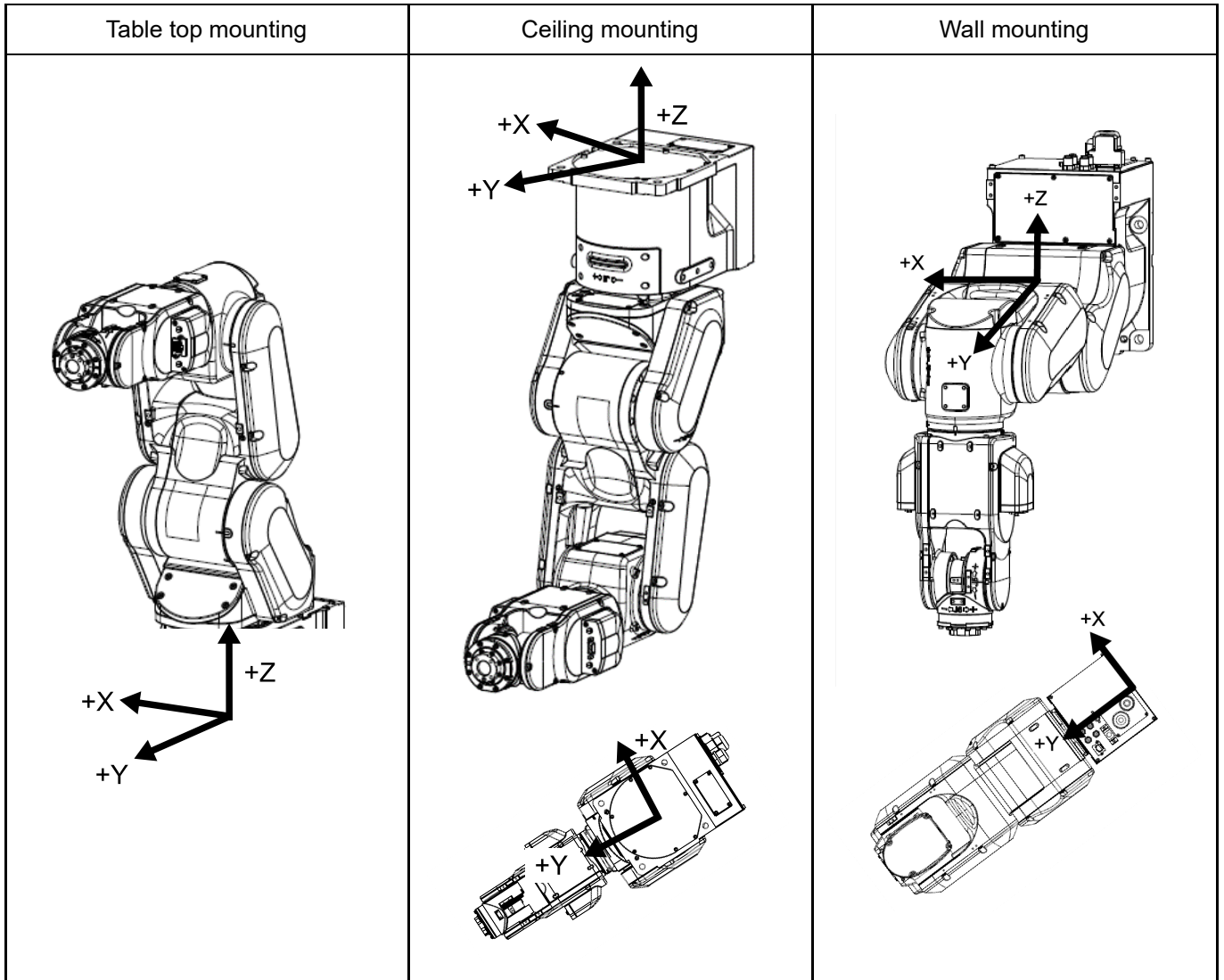

BASE setting is suitable for install the robot obliquely.

BASE setting can change a specific coordinate system of the robot and match the World coordinate system of the Jog & Teach and the coordinate system of the equipment.

For procedure of the BASE setting, refer to SPEL+ Language Reference: BASE Command.

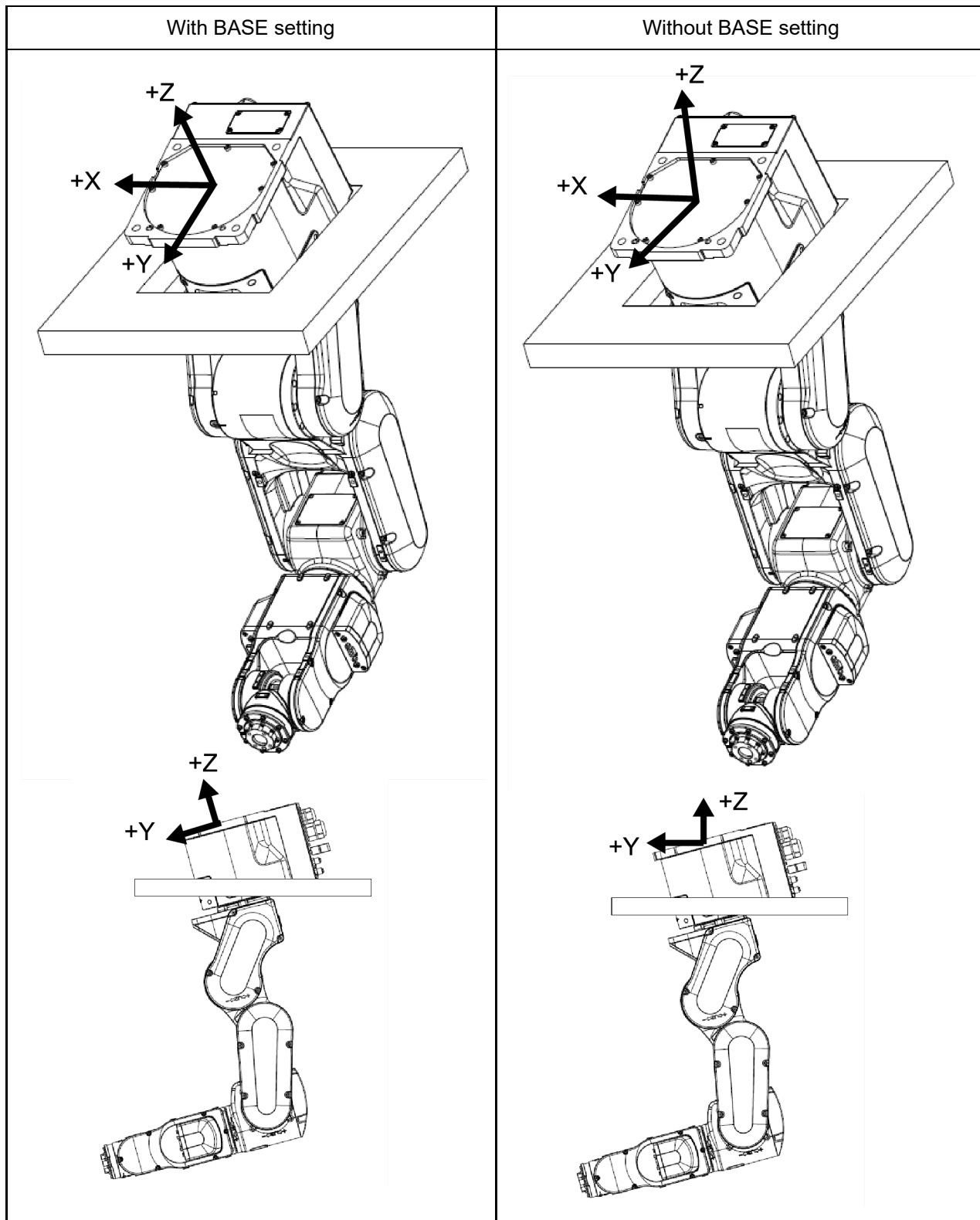

### 2.5.5 Changing the Robot

This section describes how to change the Manipulator model on Epson RC+.

(Default setting is "table top mounting".)

**⚠ CAUTION**

Changing the Manipulator should be done with great caution. It initializes the robot calibration parameters (Hofs, CalPIs), additional axis information, and PG parameter data. Before changing the robot, make sure to save the calibration data by following the procedure below.

1. Select the Epson RC+ menu-[Setup]-[System Configuration].
2. Select [Controller]-[Robots]-[Robot\*\*]-[Calibration] from the tree list. Then, click [Save].

1. Select the Epson RC+ menu-[Setup]-[System Configuration].
2. Select [Controller]-[Robots]-[Robot\*\*] from the tree list. (Dialog image: Epson RC+ 8.0)

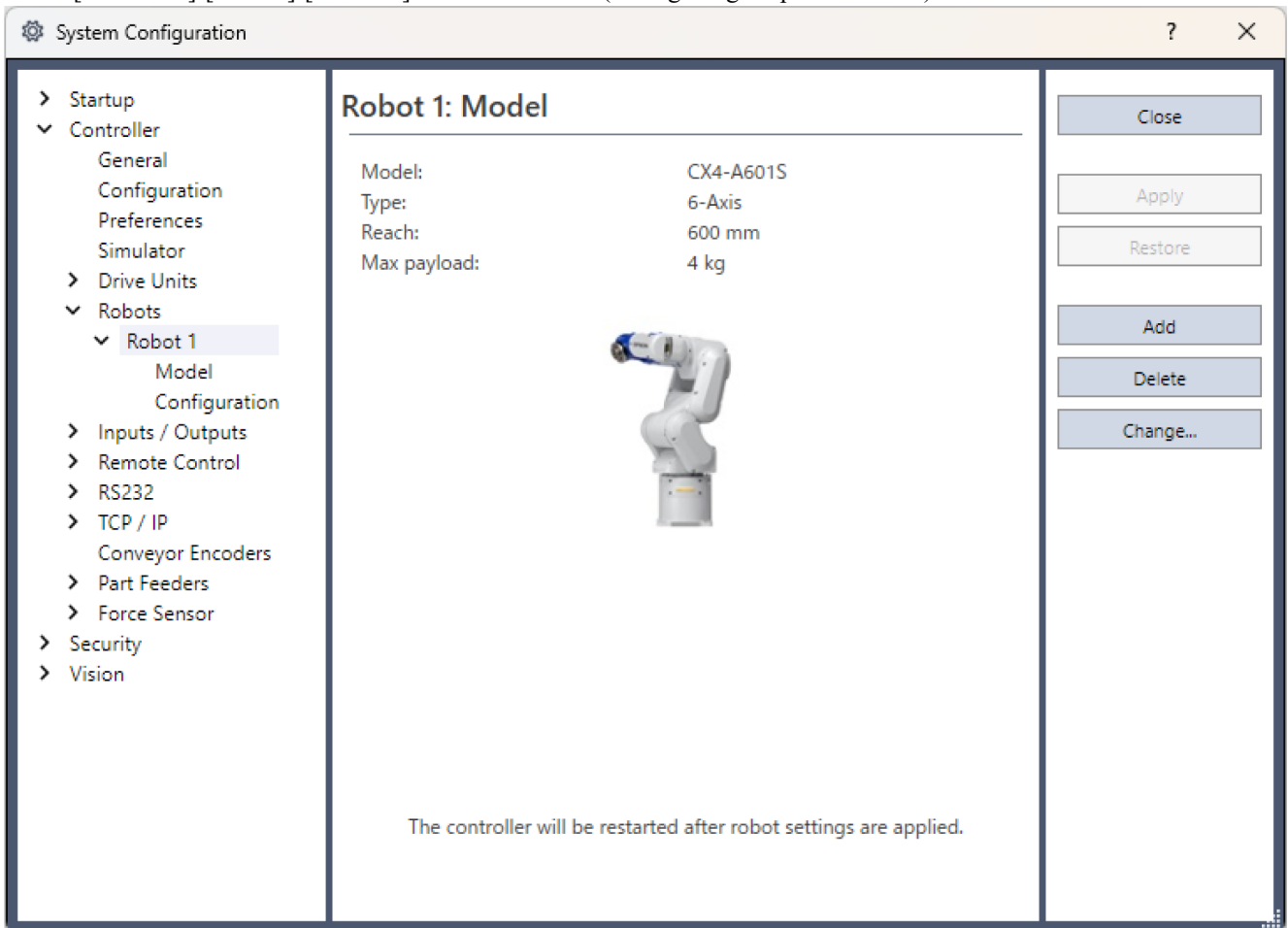

3. Click the [Change] button. The following dialog box will be displayed.

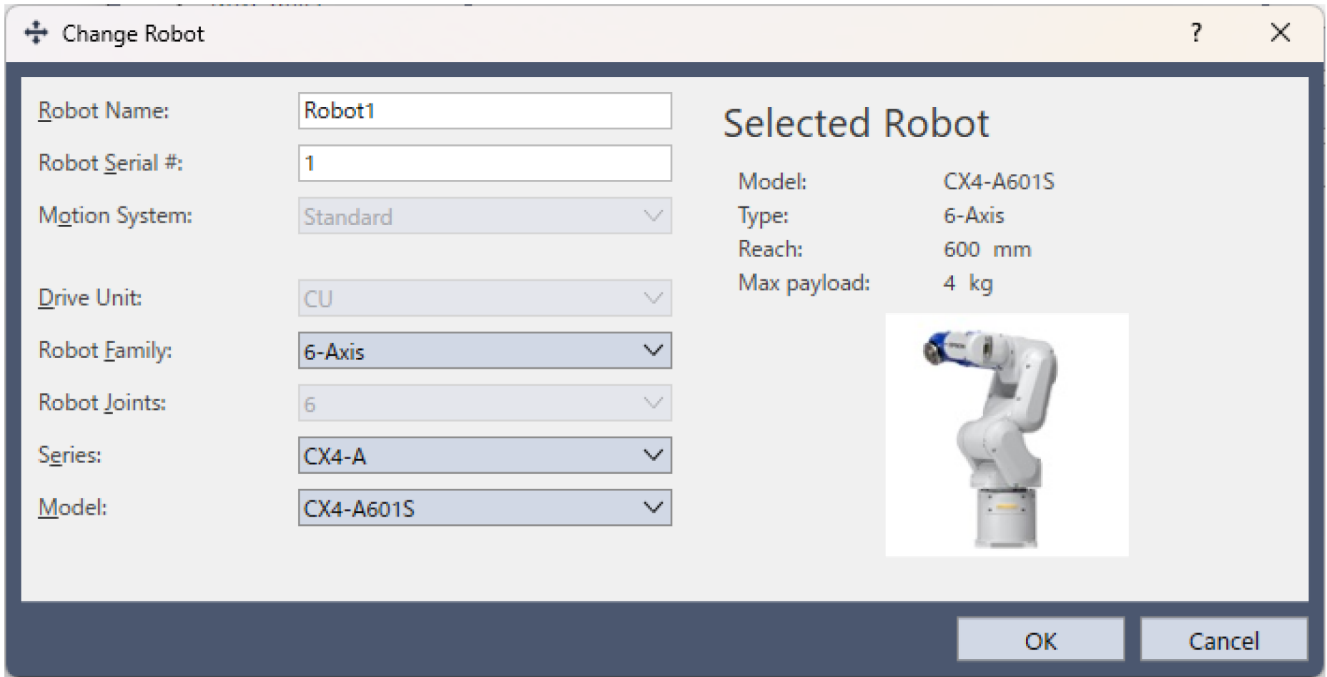

4. Input the robot name and serial number printed on the name plate of the Manipulator. Any serial number can be entered. However, enter the number printed on the Manipulator.
5. Select the robot type in the [Robot type] box.
6. Select the series name of the Manipulator in the [Series] box.
7. Select the robot model in the [Model] box.  
Available robots will be displayed according to the format of the currently installed motor driver. When [Dry run] is used, all the Manipulators of the series selected in Step 6 will be displayed. For the ceiling mount type, select the model which ends with "R" (e.g. CX4-A601SR).
8. Click the [OK] button. The Controller is restarted.

## 2.5.6 Setting the Rectangular Range in the XY Coordinate System of the Manipulator

The Cartesian (rectangular) range in the XY coordinate system of the Manipulator is specified by the limited Manipulator operation area and the XYLIM setting. The limited Manipulator operation area is defined so that the hand does not interfere with the rear side of the Manipulator. The XYLIM setting that you can determines the upper and lower limits of the X and Y coordinates.

These settings are software-based limit, and so it does not change the maximum physical range. The maximum physical range is based on the position of the mechanical stops.

These settings are disabled during a joint jogging operation. Therefore, be careful not to allow the hand to collide with the Manipulator or peripheral equipment.

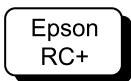

Go to [Tools] - [Robot Manager] - [Range] panel, and make the setting. You may also execute the Weight command from [Command Window].

## 2.6 Options

CX series Manipulator has the following options.

- **Brake Release Unit**
- **Camera Plate Unit**
- **C4 Compatible Flange**
- **Variable Mechanical Stop**
- **External Wiring Kit**
- **User Wires and Pneumatic Tubes**

### 2.6.1 Brake Release Unit

While the electromagnetic brake is on (such as in emergency mode), you cannot move any arm by pushing manually. You can move the Arms by hand using the brake release unit while the Controller power is off or right after unpacking.

 **KEY POINTS**

---

Precautions regarding the brake release unit

- Be sure to prepare at least one set of the brake release unit.
- Place at easy-to-reach location so that you can use it immediately when in a emergency situation.

 **WARNING**

---

- Turn off the power to the Robot Controller and brake release unit when connecting or replacing the brake release unit or external short connector. Inserting or removing connectors with the power on may result in electric shock and/or malfunction of the robot system.

 **CAUTION**

---

- Normally, release the brakes of joints one at a time. If the brakes of two or more joints must be released simultaneously due to unavoidable reasons, use extreme care. Releasing the brakes of multiple joints simultaneously may cause the arm to fall in an unexpected direction, resulting in hands or fingers getting caught or damage or failure of the Manipulator.
- After releasing the brake, the arm may fall by its own weight or move to the unexpected direction. Make sure to prepare a countermeasure to prevent the arm from falling and check the operation environment is safe.

Width	180 mm
Depth	150 mm
Height	87 mm
Weight (Cables are not included.)	1.7 kg
Cable to the Manipulator	2 m

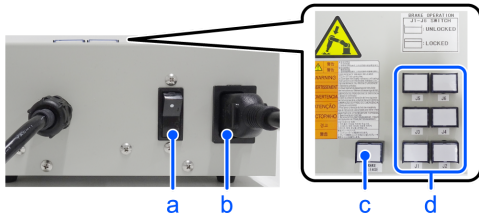

Symbol	Description
a	Power switch
b	Power Cable (You must provide.)
c	Power lamp
d	Brake release switch

### 2.6.1.1 Power Cable

You must provide a power cable. Be sure to use the specifications below.

Symbol	Item	Specifications
a	Plug	Comply with local safety regulation <ul style="list-style-type: none"> <li>Class I (2P + PE), AC250 V, 6 A or 10 A Ex.: CEE Pub.7 Certified, CCC Certified, KC Certified, BS1363 Certified, PSB Certified, BIS Certified, SABS Certified</li> <li>Class I (2P + PE), AC125 V, 7 A, 12 A, or 15 A etc. Ex.: UL Certified, PSE Certified, BSMI Certified</li> </ul>
b	Flexible cable	Comply with IEC/EN standards or local safety regulation Example: <ul style="list-style-type: none"> <li>IEC 60227-1: General requirements</li> <li>IEC 60227-5: Polyvinyl chloride insulated cables of rated voltages up to and including 450/750 V - Part 5: Flexible cables (cords)</li> <li>EN 50525-1: General requirements</li> <li>EN 50525-2-11: Electric cables - Low voltage energy cables of rated voltages up to and including 450/750 V (Uo/U) - Part 2-11: Cables for general applications - Flexible cables with thermoplastic PVC insulation</li> </ul>
c	Appliance coupler	Comply with IEC/EN standards or local safety regulation <ul style="list-style-type: none"> <li>IEC / EN 60320-1: Appliance couplers for household and similar general purposes - Part 1: General requirements</li> <li>Standard Sheet C13: AC250 V/10 A</li> </ul>

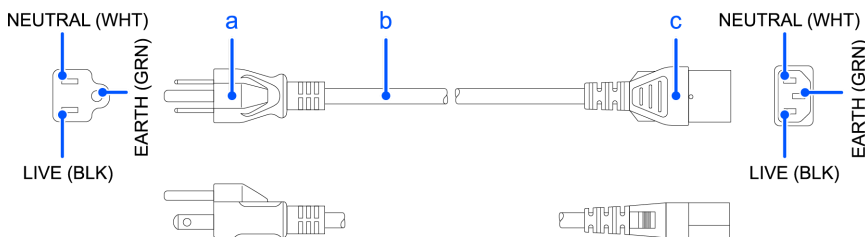

**For Japan**

Item	Specifications
Plug	PSE Certified Class I (2P+PE), AC125 V, 7 A or higher
Code	PSE Certified 0.75 mm <sup>2</sup> or more
Connector	PSE Certified IEC 60320-1 Standard Sheet C13: AC125 V/10 A or higher

### Precautions for use

#### CAUTION

- Operating the Manipulator without a brake release unit or external short connector connected may cause the brake to fail to release, possibly damaging the brake.  
After using the brake release unit, be sure to connect the external short circuit connector to the Manipulator or make sure to leave the connector for the brake release unit connected.
- Keep the external short connector. Otherwise you cannot release the brakes.
- If you turn on the brake release unit while the brake release switch is being pressed, an unintended arm may move downward. Before turning on the brake release unit, make sure that the brake release switch is not pressed.
- If you turn on the brake release unit without the connector, it may lead to the short for the male pin used in the connector. Before turning on the brake release unit, make sure that the connector is connected.

### 2.6.1.2 Installing the Brake Release Unit

1. Turn off the Controller.
2. **If the M/C power cable is not connected to the Controller:**  
Connect the M/C short connector, or connect the Controller.  
(Keep the Controller power off.)  
**If the M/C power cable is already connected to the Controller:**  
Go to the step (3).
3. Remove the external short connector.
4. Connect the brake release unit to the connector of the connection cable.

### 2.6.1.3 Removing the Brake Release Unit

1. Turn off the brake release unit.
2. Remove the power cable of the brake release unit.
3. Disconnect the brake release unit from the connector of the connection cable.
4. Connect the external short connector to the connector of the connection cable.

## 2.6.1.4 How to Use the Brake Release Unit

**⚠ CAUTION**

- After releasing the brake, the arm may fall by its own weight or move to the unexpected direction. Make sure to prepare a countermeasure to prevent the arm from falling and check the operation environment is safe.
- If the arm you released its brake moves awkwardly or faster than usual, stop the operation promptly and contact the supplier. The brake release unit may be broken. If you keep operating the Manipulator, it may lead to the breakdown of the Manipulator or you may get your hand or fingers caught.

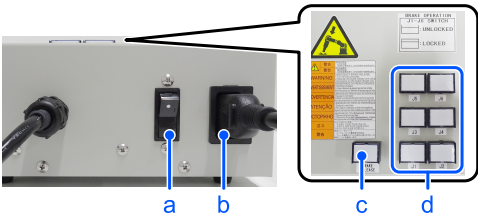

Symbol	Description
a	Power switch
b	Power cable (You must provide.)
c	Power lamp
d	Brake release switch

1. Refer to “Installing the Brake Release Unit” above to connect the brake release unit to the connector of the connection cable.
2. Plug the power cable into the brake release unit.
3. Plug the power cable into the power supply plug.
4. Turn on the brake release unit. When the brake release unit is enabled, the power lamp lights up.
5. Press the switch of the arm (J1 to J6) you want to move and then move the arm. Press the switch again. The brake will be released. The brake will be enabled by pressing the switch once again.

**✍ KEY POINTS**

Move the arm the brake is released by two persons or more (one presses the switch and one moves the arm). The arm can be very heavy and needs the significant force to move.

## 2.6.2 Camera Plate Unit

To mount a camera to the CX series Manipulator, you need to mount the camera plate unit first.

### Appearance of arm end with camera

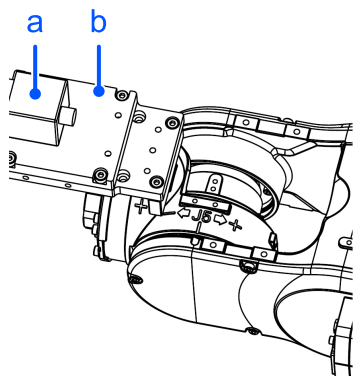

Symbol	Description
a	Camera
b	Camera Plate Unit

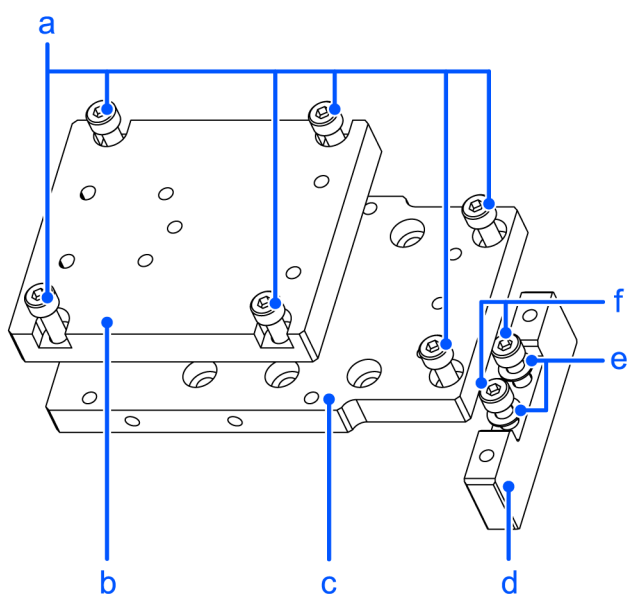

Parts Included		Qty.
a	Hexagon socket head cap bolt M4×12	6
b	Camera adapter plate	1
c	Camera mid plate	1
d	Camera base plate	1
e	Plain washer for M4 (small washer)	2
f	Hexagon socket head cap bolt M4×20	2

**Installation**

**KEY POINTS**

For details of tightening the hexagon socket head cap bolt, refer to the following section.

**Tightening the Hexagon Socket Head Cap Bolts**

1. Mount the camera base plate to the Manipulator.  
2×M4×20+Plain washer for M4 (small washer)

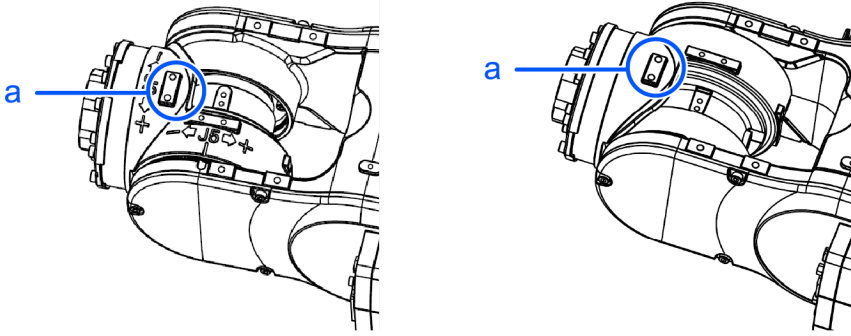

Symbol	Description
a	Mounting holes for the camera base plate

2. Mount the camera mid plate to the base plate.  
2×M4×12

**KEY POINTS**

The motion range and dimension of the Manipulator with the camera installed may vary depending on the mounting hole of camera mid plate. The details are described in the table below.

3. Mount the camera to the camera adapter plate.

**KEY POINTS**

According to the camera, the available mounting hole of adapter plate will be different. The details are described below.

4. Mount the camera adapter plate and camera to the camera mid plate.  
4×M4×12
5. Secure the cables at the position where they do not interfere with the Manipulator motion.

**KEY POINTS**

When securing the cables, check if the cables bend radius is big enough and the cables are not rubbing against each other while the Manipulator moves. Otherwise, the cables will be disconnected.

**Dimension of the camera plate unit**

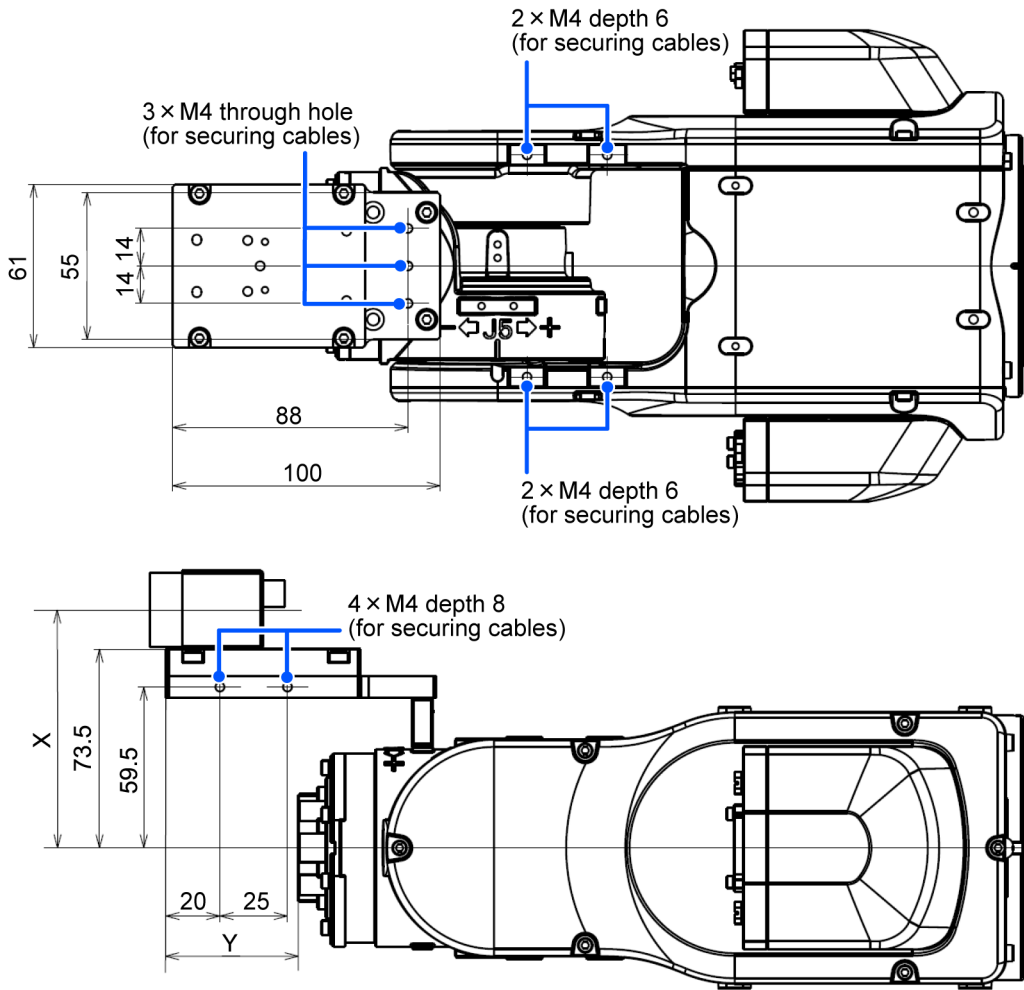

Dimensions X and Y will change depending on the position of camera mid plate and camera size. Refer to the table below for the values.

**Camera mid plate**

The camera mid plate uses the mounting holes A to D.

By using the different mounting holes, it can be mounted to the camera base plate in the different four positions.

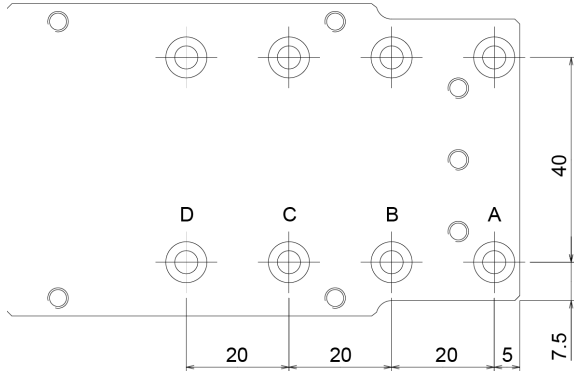

**Camera adapter plate**

Each camera uses the different mounting holes.

- USB camera: J (2 holes)

- GigE camera: E (3 holes)

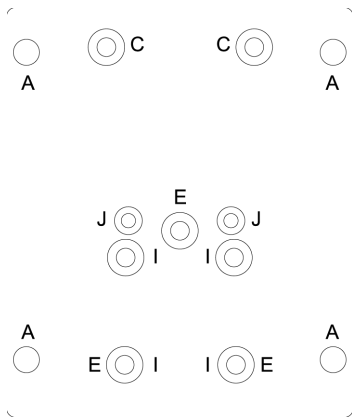

**Mounting example**

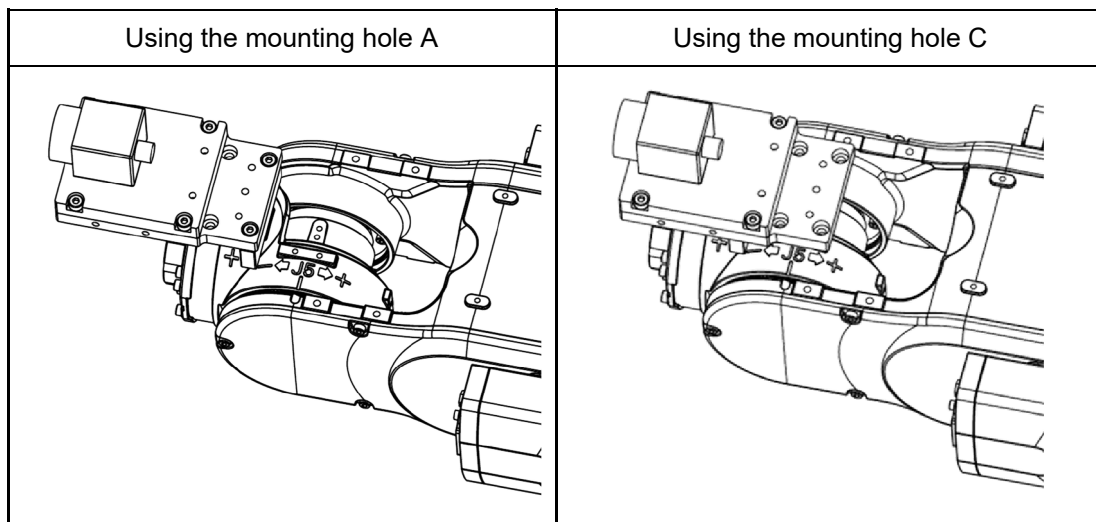

E.g.) Camera: XC-ES30

**Camera and Joint #5 motion range (reference values)**

The Joint #5 motion range varies depending on the mounting position of camera mid plate and the camera you are using.

The table below shows the motion range (reference values) based on the available cameras for this option and the mounting positions of the camera mid plate. The values in the table may vary depending on how to secure the cables.

By changing the Y position, you can extend the distance from the hand mounting surface to the camera. Also, you can attach the larger end effector. However, be careful about the Joint #5 motion range that will be limited in this case.

USB Camera, GigE Camera	A	B	C	D	X
CX4-A series (Top surface mounting)	-135°~+60°	-135°~+50°	-135°~+35°	-135°~+25°	93 mm
CX4-A series (Bottom surface mounting)	-60°~+135°	-50°~+135°	-35°~+135°	-25°~+135°	93 mm
CX7-A series (Top surface mounting)	-135°~+60°	-135°~+50°	-135°~+40°	-135°~+35°	88 mm
CX7-A series (Bottom surface mounting)	-60°~+135°	-50°~+135°	-40°~+135°	-35°~+135°	88 mm

Y	A	B	C	D
CX4-A series	49 mm	29 mm	9 mm	-11 mm

Y	A	B	C	D
CX7-A series	43 mm	23 mm	3 mm	-17 mm

### Direction of the Joint #5 motion

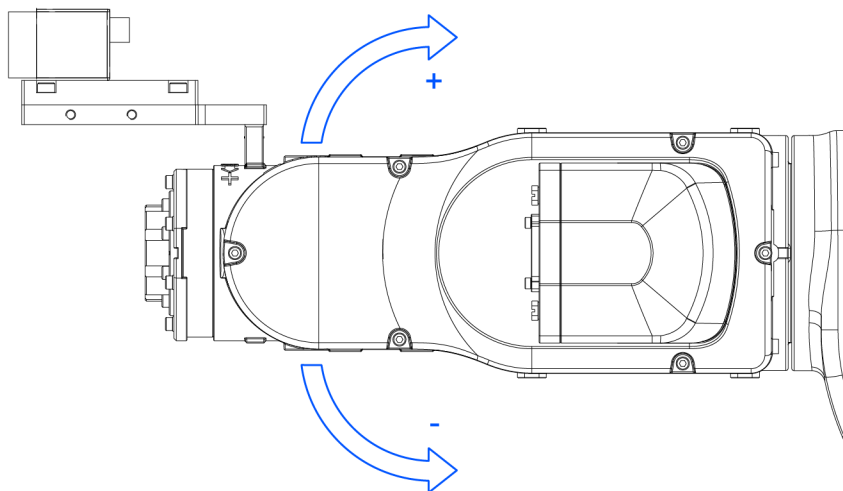

## 2.6.3 C4 Compatible Flange

This is a plate that allows you to mount the hand used in the C4 series or the hand designed for the ISO flange to the CX series Manipulator.

Parts Included		Qty.
a	Hexagon socket head cap bolt M4×10	6
b	C4 Compatible Flange	1
c	Hexagon socket head cap bolt M5×10	4
d	Flange	1
e	Dowel pin 5×15	1

### Dimensions

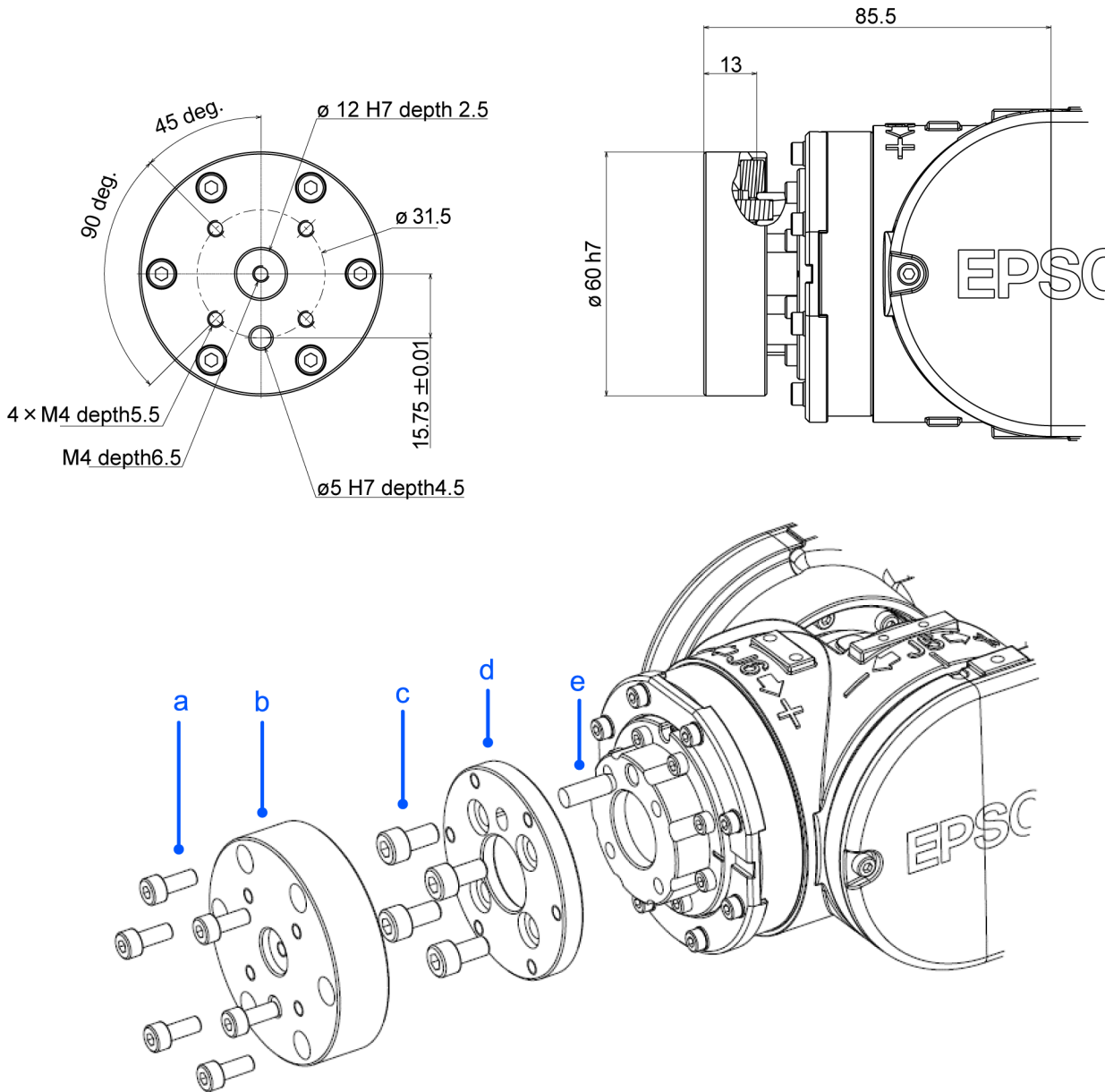

depth = depth of threaded hole

90° pitch

\* Each dimension and tolerance complies with ISO9409-1-31.5-4-M5.

**Installation**

**KEY POINTS**

For details of tightening the hexagon socket head cap bolt, refer to the following section.

**Tightening the Hexagon Socket Head Cap Bolts**

1. Align the outer diameter (ø40h8) of the flange on the end of the Arm and the flange hole (ø40H7).
2. Insert the dowel pin from the flange side and position the Arm and the flange.
3. Secure the flange with 4 hexagon socket head cap bolts.

4×M5×10

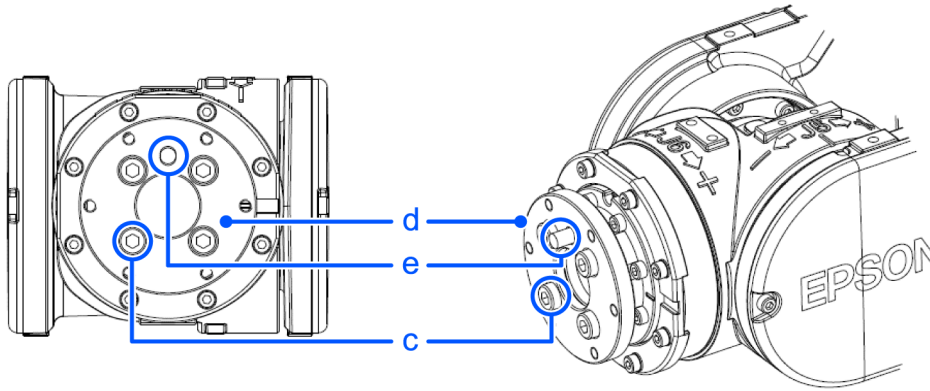

**KEY POINTS**

If you move the Manipulator with the dowel pin inserted, the dowel pin will fall out.

- 4. Align the outer diameter of the flange (ø56h7) and the flange hole (ø56H7) of the C4 compatible flange so that the dowel pin fits the dowel pin hole of the C4 compatible flange.
- 5. Secure the C4 compatible flange with 6 hexagon socket head cap bolts.

6×M4×10

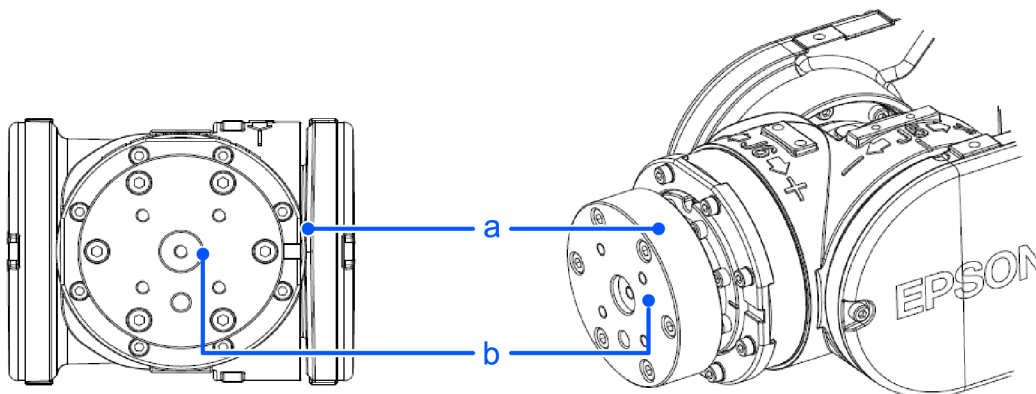

**2.6.4 Variable Mechanical Stop**

This option is used to mechanically limit the motion range of the Manipulator.

For installation and angle restriction measures, refer to the following section.

**Setting the Work Envelope by Mechanical Stops**

**Variable Mechanical Stop (J1)**

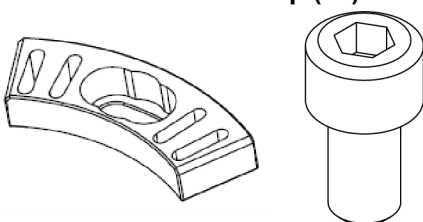

Parts Included		Qty.
a	Mechanical Stop (J1)	1
b	Hexagon socket head cap bolt M10×20	1

## 2.6.5 External Wiring Kit

Using the external wiring kit, you can fix the wirings and pneumatic tubes for the hand along with the Manipulator. The external wiring kit can be used to select the cable fixing plate, according to your Manipulator’s operation condition. For details of tightening the hexagon socket head cap bolt, refer to the following section.

### Tightening the Hexagon Socket Head Cap Bolts

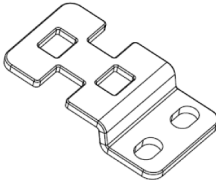
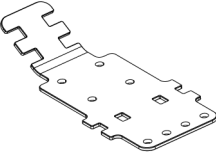
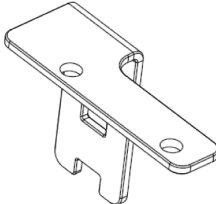
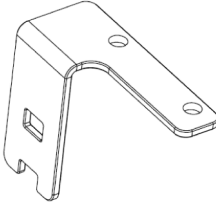
Parts Included		Qty.
Cable fixing plate	Common products for the base, Joint #2, and Joint #3 	6
	For Joint #4 	1
	Joint #5-1 	1
	Joint #5-2 	1
Wire tie		15
Cable protection sheet		10
Hexagon socket head cap bolt M4×8		20
Hexagon strut BSF410-E		4

### Location for cable fixing plates

There are two mounting positions for the base on both sides. Use each cable fixing plate to select the location suitable for the

cable routing according to your Manipulator's operation condition.

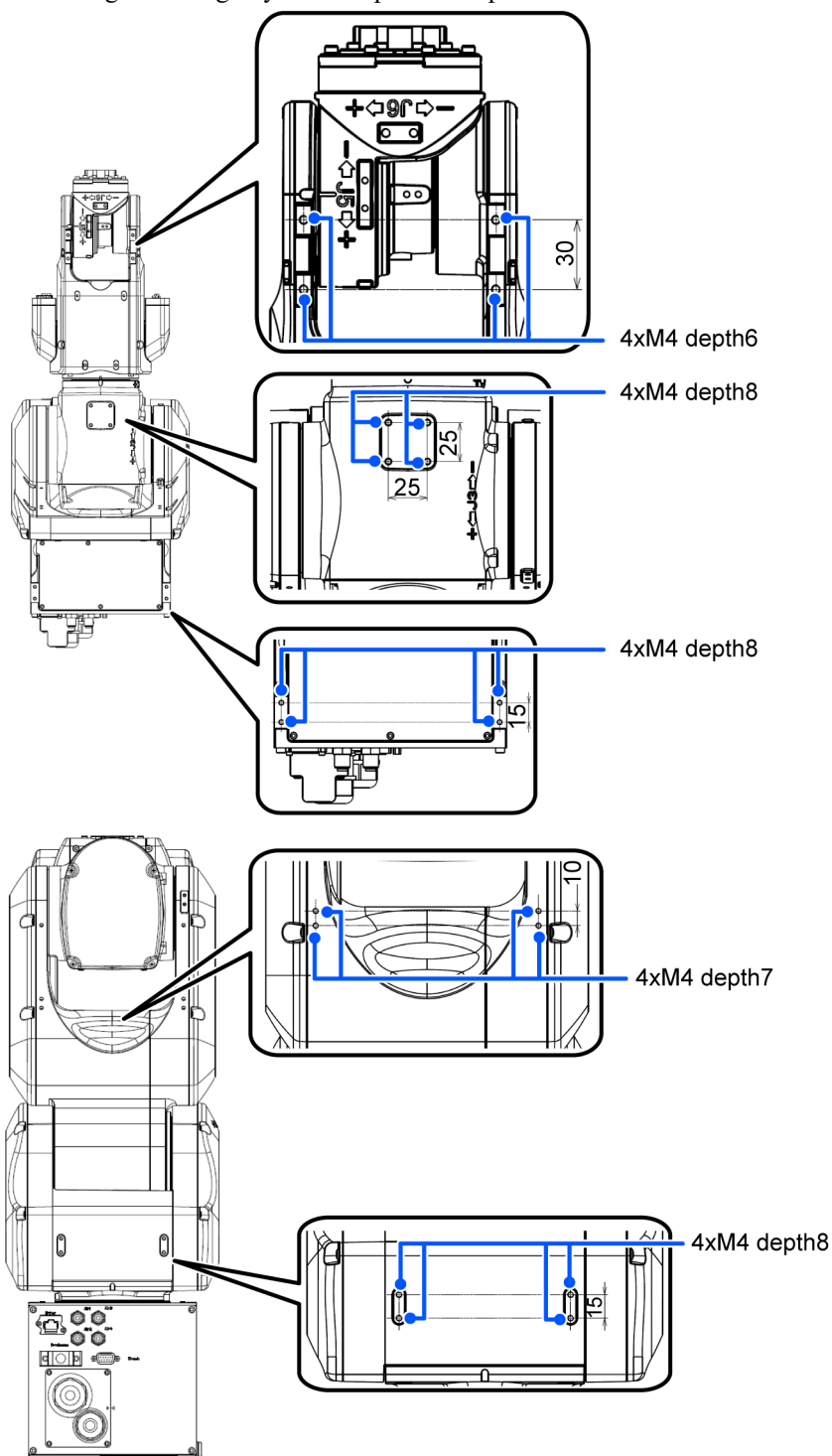

### How to mount the cable fixing plates

#### For the Base

1. Mount the cable fixing plate (a) on your Manipulator.

Hexagon socket head cap bolt (b): 2-M4× 8

Tightening Torque:  $4.0 \pm 0.2 \text{ N}\cdot\text{m}$

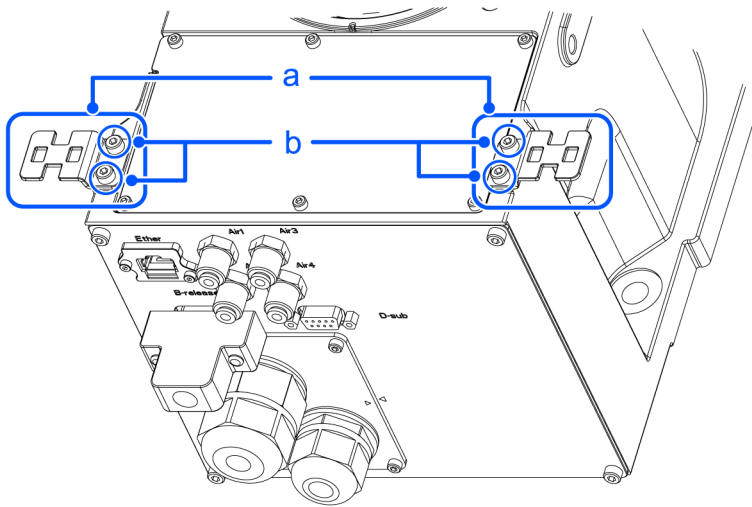

Put the wire tie (a) through the cutout for fixing the cables on the cable fixing plate. Then, bind the cables with the wire tie over the cable protection sheet (b).

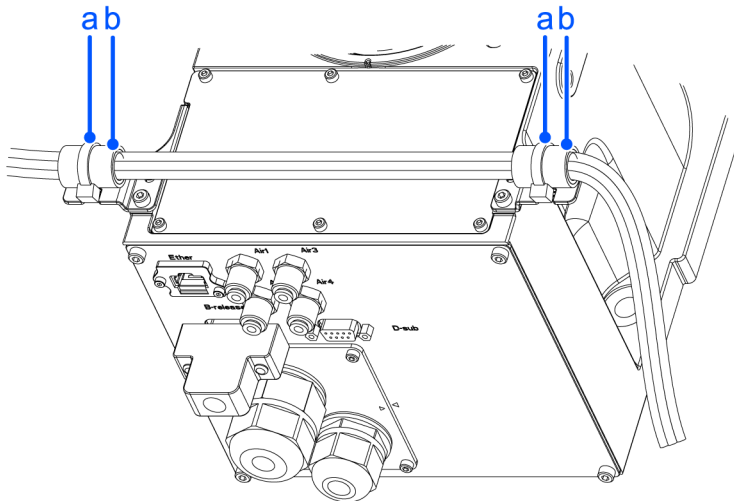
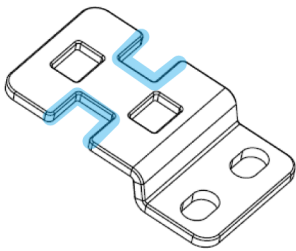

**KEY POINTS**

When binding the cables, be sure to make extra length so that the cables will not be tight while each joint operates and the bending radius is within the specifications of the cable.

**For Joint #2**

1. Mount the cable fixing plate (a) on your Manipulator.

Hexagon socket head cap bolt (b): 4-M4× 8

Tightening Torque:  $4.0 \pm 0.2 \text{ N}\cdot\text{m}$

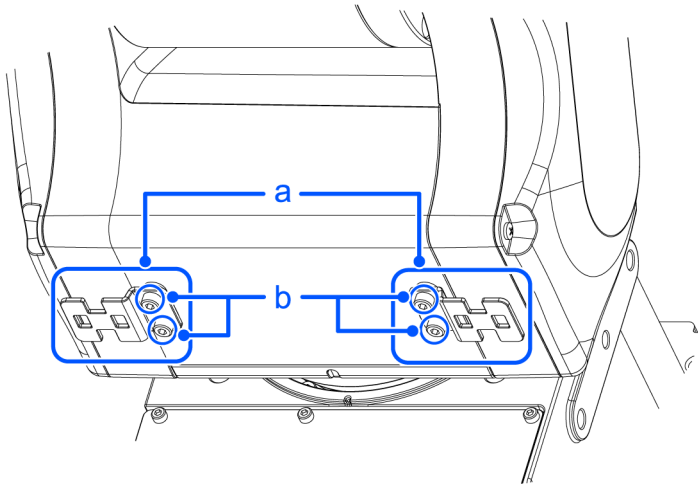

Put the wire tie (a) through the cutout for fixing the cables on the cable fixing plate. Then, bind the cables with the wire tie over the cable protection sheet (b).

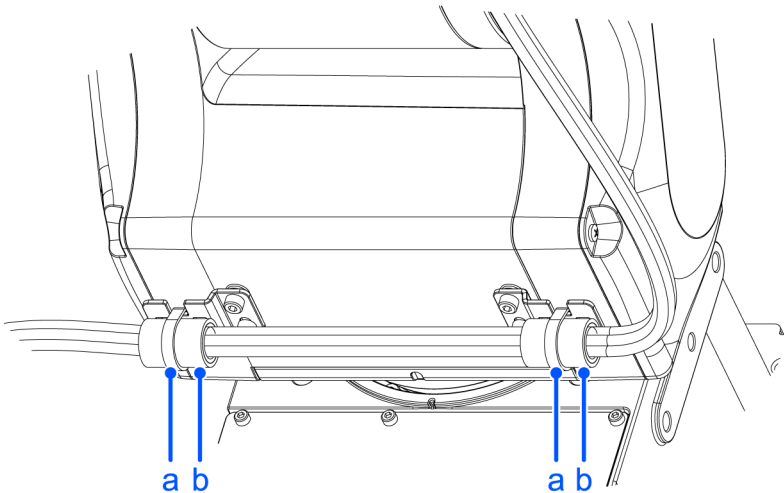
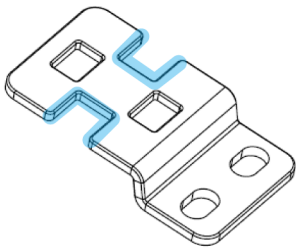

### KEY POINTS

When binding the cables, be sure to make extra length so that the cables will not be tight while each joint operates and the bending radius is within the specifications of the cable.

**For Joint #3**

- 1. Mount the cable fixing plate (a) on your Manipulator.  
Hexagon socket head cap bolt (b): 4-M4× 8  
Tightening Torque:  $4.0 \pm 0.2 \text{ N}\cdot\text{m}$

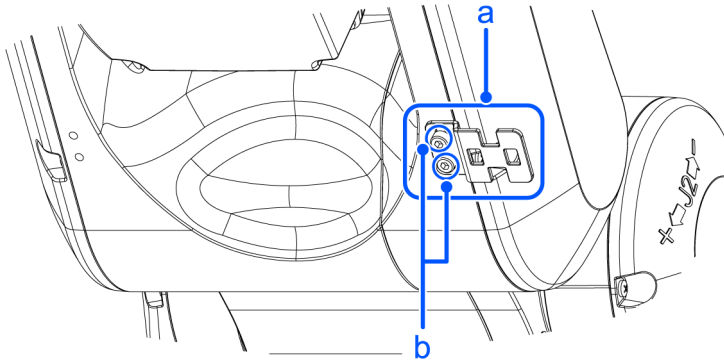

Put the wire tie (a) through the two slotted holes for fixing the cables on the cable fixing plate. Then, bind the cables with the wire tie over the cable protection sheet (b).

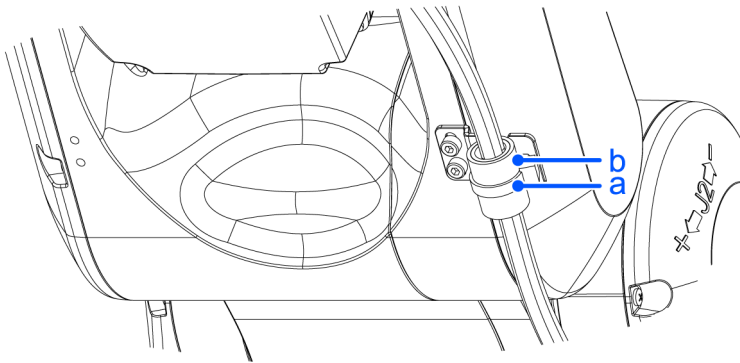
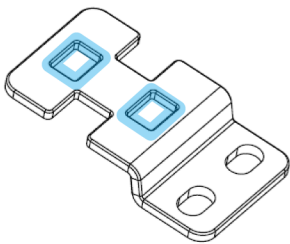

 **KEY POINTS**

When binding the cables, be sure to make extra length so that the cables will not be tight while each joint operates and the bending radius is within the specifications of the cable.

**For Joint #4**

- 1. Mount the cable fixing plate (a) on your Manipulator.  
Hexagon socket head cap bolt (b): 4-M4× 8

Tightening Torque:  $4.0 \pm 0.2 \text{ N}\cdot\text{m}$

Hexagon strut (c): BSF410-E×4

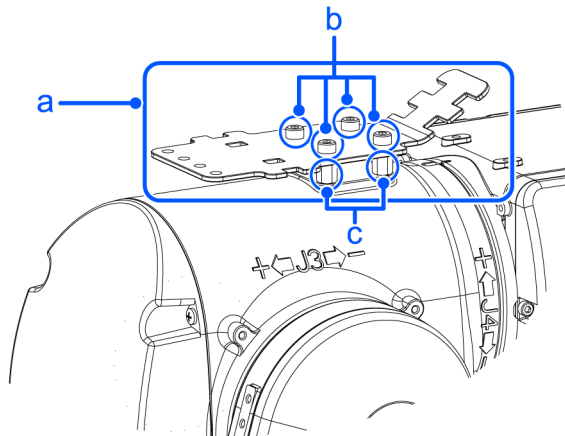

Put the wire tie (a) through the cutout and the slotted hole for fixing the cables on the cable fixing plate. Then, bind the cables with the wire tie over the cable protection sheet (b).

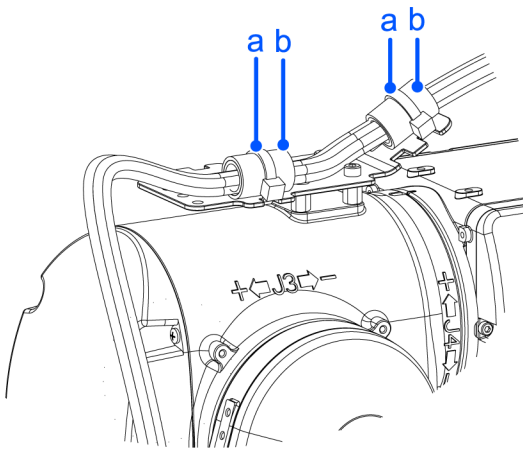
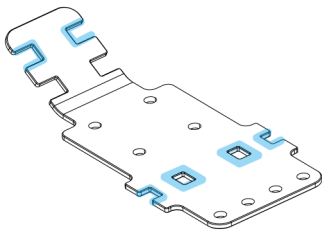

### KEY POINTS

When binding the cables, be sure to make extra length so that the cables will not be tight while each joint operates and the bending radius is within the specifications of the cable.

### Joint #5-1

1. Mount the cable fixing plate (a) on your Manipulator.

Hexagon socket head cap bolt (b): 4-M4× 8

Tightening Torque:  $4.0 \pm 0.2 \text{ N}\cdot\text{m}$

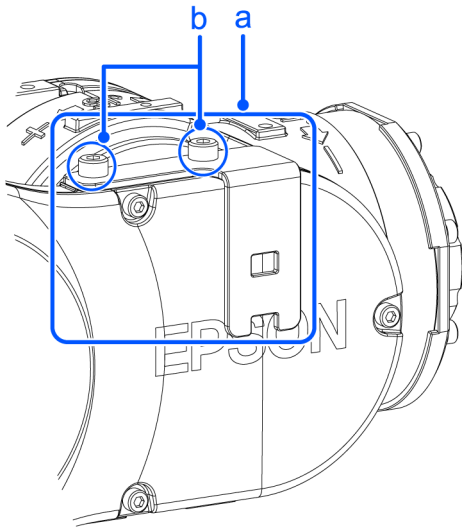

Put the wire tie (a) through the cutout and the slotted hole for fixing the cables on the cable fixing plate. Then, bind the cables with the wire tie over the cable protection sheet (b).

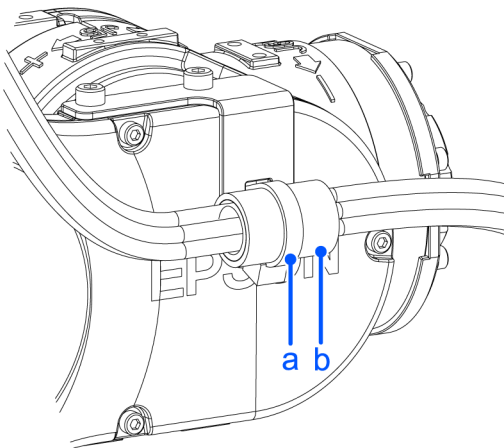
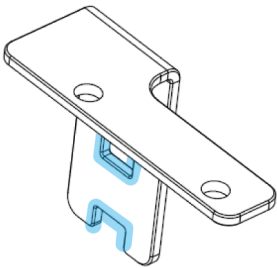

#### KEY POINTS

When binding the cables, be sure to make extra length so that the cables will not be tight while each joint operates and the bending radius is within the specifications of the cable.

1. Mount the cable fixing plate (a) on your Manipulator.  
Hexagon socket head cap bolt (b): 4-M4× 8  
Tightening Torque:  $4.0 \pm 0.2 \text{ N}\cdot\text{m}$

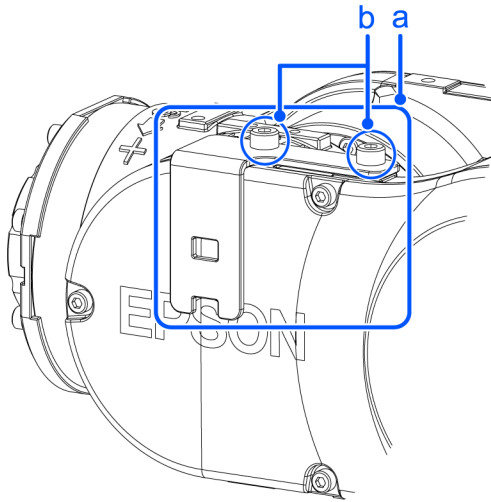

Put the wire tie (a) through the cutout and the slotted hole for fixing the cables on the cable fixing plate. Then, bind the cables with the wire tie over the cable protection sheet (b).

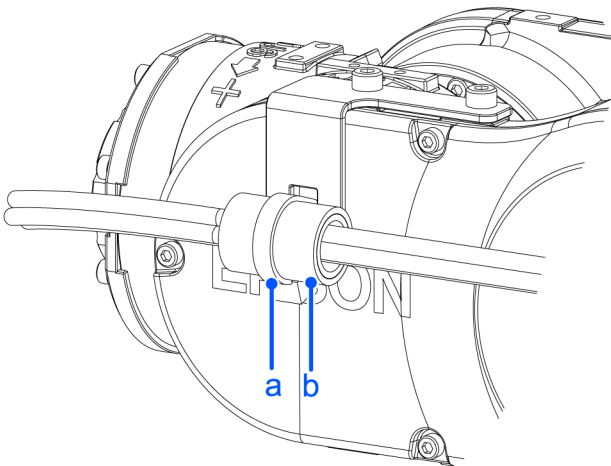
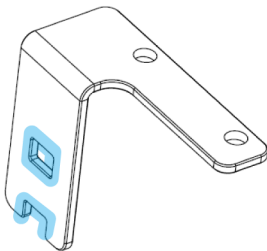

 **KEY POINTS**

When binding the cables, be sure to make extra length so that the cables will not be tight while each joint operates and the bending radius is within the specifications of the cable.

## 2.6.6 User Wires and Pneumatic Tubes

Use the following options when using the internal wiring and tubing for the hand drive.

### Fitting for Customer Use (ø4 Straight)

Parts Included	Qty.	Manufacturer	Type
ø4 straight fitting	4	SMC	KQ2H04-M5N

\* Attached as standard. The parts can be purchased additionally in case of lost or shortage.

### Fitting for Customer Use (ø4 Elbow)

Parts Included	Qty.	Manufacturer	Type
ø4 elbow fitting	4	SMC	KQ2L04-M5N

\* Attached as standard. The parts can be purchased additionally in case of lost or shortage.

### Standard User Connector Kit (D-sub)

Parts Included	Qty.	Manufacturer	Type
Connector	2	JAE	DE-9PF-N (Solder type)
Clamp hood	2	HRS	HDE-CTH (4-40) (10) (Connector setscrew: # 4- 40 UNC)

\* Attached to standard and cleanroom-model Manipulators as standard. The parts can be purchased additionally in case of lost or shortage.

### Waterproof User Connector Kit (D-sub)

Parts Included	Qty.	Manufacturer	Type
Connector	2	HARTING	09 67 009 5615 (Solder type)
Clamp hood	2	HARTING	09 67 009 0538 (Connector setscrew: #4-40 UNC)

\* Attached to the protected-model Manipulators as standard. The parts can be purchased additionally in case of lost or shortage.

### Waterproof User Connector Kit (Ethernet)

Parts Included	Qty.	Manufacturer	Type
Connector	2	HARTING	09 45 145 1560

\* Not attached as standard. Please purchase the item if needed. Please note that the protection rating IP67 cannot be satisfied if other connectors are used.

## **3. CX7-A Manipulator**

This chapter contains information for setup and operation of the Manipulators.

Please read this chapter thoroughly before setting up and operating the Manipulators.

## 3.1 Safety

The Manipulator and its related equipment should be unpacked and transported by people who have received installation training provided by Epson and the suppliers. Also, the laws and regulations of the installation country must be followed.

Before use, please read this manual and other related manuals to ensure correct use. After reading this manual, store it in an easily accessible location for future reference.

This product is intended for transporting and assembling parts in a safely isolated area.

### 3.1.1 Conventions Used in This Manual

The following symbols are used in this manual to indicate important safety information. Be sure to read the descriptions shown with each symbol.

#### WARNING

This symbol indicates an imminently hazardous situation which, if operation is not performed properly, will result in death or serious injury.

#### WARNING

This symbol indicates a potentially hazardous situation which, if operation is not performed properly, could result in an injury due to electric shock.

#### CAUTION

This symbol indicates a potentially hazardous situation which, if operation is not performed properly, may result in a minor or moderate injury or in property damage only.

### 3.1.2 Design and Installation Safety

The robot system should be designed and installed by people who have received installation training provided by Epson and the suppliers.

Design personnel should refer to the following manuals:

- "Safety Manual"
- "Controller Manual"
- "Manipulator Manual"

Refer to the following section for the installation safety information.

#### [Environment and Installation](#)

Be sure to read this section and follow the safety information before installation to ensure that the installation work is performed safely.

### 3.1.3 Operation Safety

The following items are safety precautions for operating personnel:

#### WARNING

- Be sure to read the Safety Manual before use. Operating the robot system without understanding the safety information can be extremely dangerous and may result in serious injury or severe equipment damage.
- Before operating the robot system, make sure that no one is inside the safety barriers. The robot system can be operated in the teaching operation mode even when someone is inside the safety barriers. Even though the motion of the Manipulator is always restricted (low speed and low power) to ensure operator safety, an unexpected movement by the Manipulator can be extremely dangerous and may cause serious safety problems.
- If the Manipulator moves abnormally during operation of the robot system, immediately press the emergency stop switch.

#### WARNING

- To perform the power supply lockout, remove the power plug. Be sure to connect the AC power cable to a power outlet. Do not connect it directly to a factory power source.
- Before performing any replacement work, inform others in the area that you are working, and then turn off the Controller and related equipment, and unplug the power cable from the power source. Performing any work procedure with the power turned on is extremely dangerous and may result in electric shock and/or malfunction of the robot system.
- Do not connect or disconnect the connector of the M/C cable while the Controller is turned on. There is a risk the Manipulator may malfunction, which is extremely hazardous. Also, performing any work procedure with the power turned on may result in electric shock and/or malfunction of the robot system.

#### CAUTION

- Whenever possible, only one person should operate the robot system. If it is necessary to operate with more than one person, ensure that all personnel communicate with each other and take all necessary safety precautions.
- If the Manipulator is operated repeatedly with each joint having an operating angle of 5° or less, the bearings used in the joints are likely to cause oil film shortage. Repeated operation may cause premature damage. To prevent premature damage, operate the Manipulator to move each joint to an angle of 30° or more about once per hour.
- When the robot is operating at low speed (Speed: 5 to 20%), vibration (resonance) may occur continuously during operation depending on the combination of the arm orientation and hand load. Vibration occurs due to the natural vibration frequency of the arm and can be reduced by taking the following measures:
  - Changing the robot speed
  - Changing the teach points
  - Changing the hand load

### 3.1.4 Emergency Stop

Each robot system needs equipment that will allow the operator to immediately stop the system's operation. Install an emergency stop device by using emergency stop input from the Controller or other equipment.

Before using the emergency stop switch, be aware of the following points.

- The emergency stop switch should be used to stop the Manipulator only in case of emergencies.
- Besides pressing the emergency stop switch when an emergency occurs, to stop the Manipulator during program operation, use the Pause or STOP (program stop) statements assigned to a standard I/O.  
The Pause and STOP statements do not turn off motor energization, and so the brake is not locked.

To place the robot system in emergency stop mode in a non-emergency (normal) situation, press the emergency stop switch while the Manipulator is not operating.

Do not press the emergency stop switch unnecessarily while the Manipulator is operating normally.

It could shorten the lifespan of the following components.

- Brakes  
The brakes will be locked, which will shorten the lifespan of the brakes due to worn brake friction plates.
  - Normal brake lifespan:  
About 2 years (when the brakes are used 100 times/day)  
or about 20,000 times
- Reduction gears  
An emergency stop applies an impact to the reduction gear, which can shorten its life.

If the Manipulator is stopped by turning off the Controller while it is operating, the following problems may occur.

- Reduced life and damage to reduction gear
- Position shift at the joints

If a power outage or other unavoidable Controller power-off occurs during Manipulator operation, check the following points after power is restored.

- Damage in reduction gear
- Shifting of the joints from their proper positions

If there was any shifting, maintenance is required. For more information, please contact the supplier.

#### Stopping distance of emergency stop

The Manipulator during operation cannot stop immediately after the emergency stop switch is pressed. Also, the stopping time and movement distance vary depending on the following factors.

- Hand weight, WEIGHT setting, ACCEL setting, workpiece weight, SPEED setting, movement posture, etc.

For the stopping time and movement distance of the Manipulator, refer to the following section.

#### [Appendix B: Stopping Time and Stopping Distance at Emergency Stop](#)

### 3.1.5 Safeguard (SG)

To maintain a safe working zone, safety barriers must be set up around the Manipulator, and safeguards must be installed at the entrance and exit of the safety barriers.

The term "safeguard" as used in this manual refers to a safety device with an interlock that allows entry into the safety barriers. Specifically, this includes safety door switches, safety barriers, light curtains, safety gates, safety floor mats, and so on. The safeguard is an input that informs the Robot Controller that an operator may be inside the safeguard area. You must assign at least one Safeguard (SG) in Safety Function Manager.

When the safeguard is opened, Protective Stop operates to change to the safeguard open state (display: SO).

- **Safeguard open**  
Operations are prohibited. Further robot operation is not possible until either the safeguard is closed, the latched state is released, and a command is executed, or the TEACH or TEST operation mode is turned on and the enable circuit is activated.
- **Safeguard closed**  
The robot can operate automatically in an unrestricted (high power) state.

### WARNING

- If a third party accidentally releases the safeguard while an operator is working inside the safety barriers, this may result in a hazardous situation. To protect the operator working inside the safety barriers, implement measures to lock out or tag out the latch release switch.
- To protect operators working near the robot, be sure to connect a safeguard switch and make sure that it works properly.

### Installing safety barriers

When installing safety barriers within the maximum range of the Manipulator, combine safety functions such as SLP. Carefully take into account the size of the hand and the workpieces to be held so that no interference occurs between the operating parts and the safety barriers.

### Installing safeguards

Design the safeguards so that they satisfy the following requirements:

- When using a key switch type safety device, use a switch that forcibly opens the interlock contacts. Do not use switches that open their contacts using the spring force of the interlock.
- When using an interlock mechanism, do not disable the interlock mechanism.

### Considering the stopping distance

During operation, the Manipulator cannot stop immediately even if the safeguard is opened. Also, the stopping time and movement distance vary depending on the following factors.

- Hand weight, WEIGHT setting, ACCEL setting, workpiece weight, SPEED setting, movement posture, etc.

For the stopping time and movement distance of the Manipulator, refer to the following section.

[Appendix C: Stopping Time and Stopping Distance When Safeguard is Open](#)

### Precautions for safeguard operation

Do not open the safeguard unnecessarily while the motor is energized. Frequent safeguard inputs will reduce the life of the relay.

- Normal relay lifespan: About 20,000 times

## 3.1.6 How to Move Arms with the Electromagnetic Brake

There are two methods to release the electromagnetic brake. Follow either method to release the electromagnetic brake and move the arms manually.

- **When using a brake release unit**  
Follow the method when you just unpack the delivered boxes or when the Controller does not start up yet.
- **When using software**  
Follow the method when you can use the software.

While the electromagnetic brake is on (such as in emergency mode), you cannot move any arm by pushing manually.

**Arm Motion**

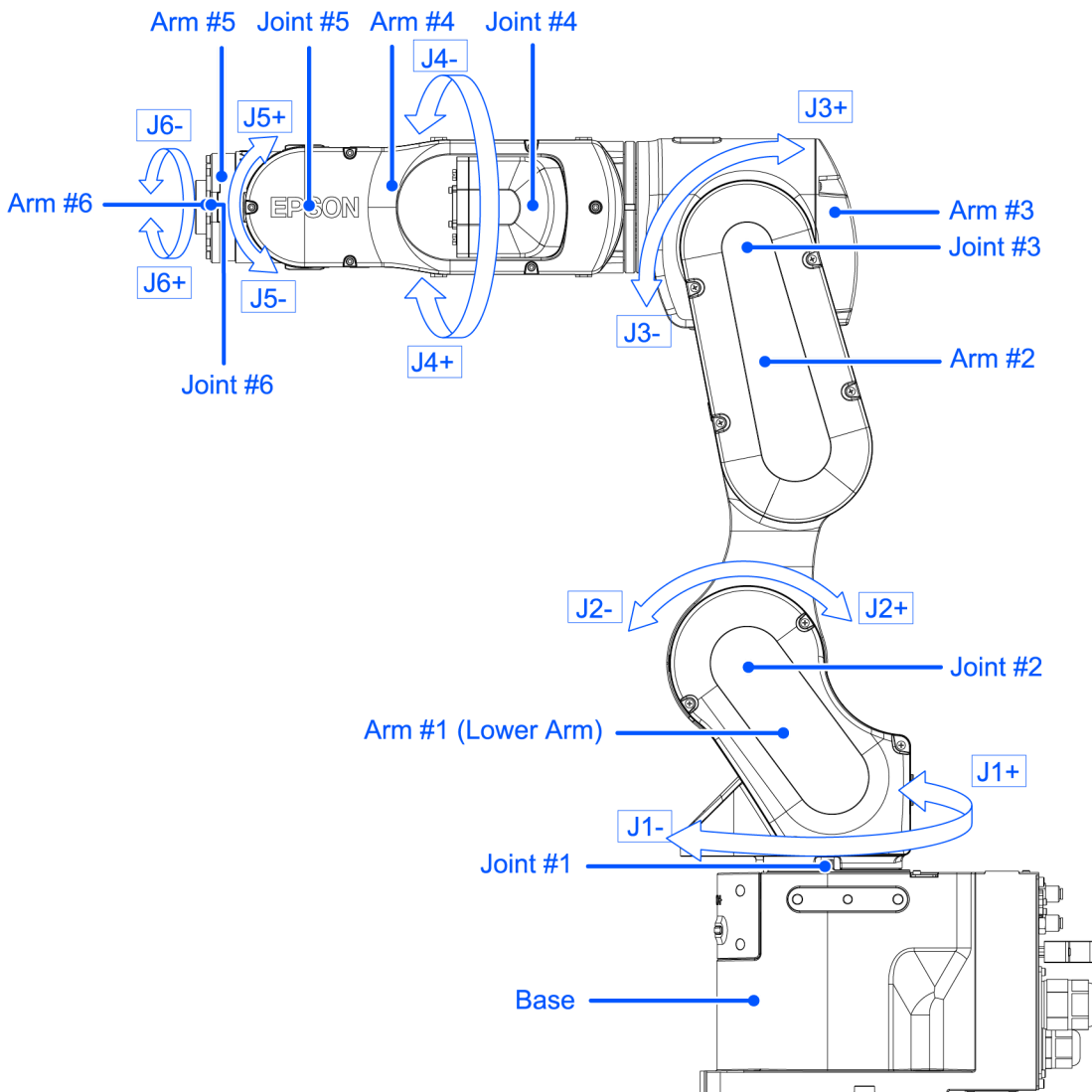

**3.1.6.1 When using a brake release unit**

This series has the Brake Release Unit as an option. For details, refer to the following section.

**Options**

**3.1.6.2 When using software**

**⚠ CAUTION**

- Normally, release the brakes of joints one at a time. If the brakes of two or more joints must be released simultaneously due to unavoidable reasons, use extreme care. Releasing the brakes of multiple joints simultaneously may cause the arm to fall in an unexpected direction, resulting in hands or fingers getting caught or damage or failure of the Manipulator.
- After releasing the brake, the arm may fall by its own weight or move to the unexpected direction. Make sure to prepare a countermeasure to prevent the arm from falling and check the operation environment is safe.
- Before releasing the brake, be sure to keep the emergency stop switch in an easily accessible location so that you can immediately press it if necessary. Otherwise, if the emergency stop switch is not easily accessible, you will be unable to immediately stop the arm falling due to an erroneous operation, which could lead to Manipulator damage or breakdown.

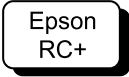

After releasing the Emergency Stop switch, execute the following command in [Command Window].

```
>Reset
>Brake Off, [The number (from 1 to 6) corresponding to the arm whose brake will be
turned off]
```

Execute the following command to turn on the brake again.

```
>Brake On, [The number (from 1 to 6) corresponding to the arm whose brake will be
turned on]
```

### 3.1.7 Precaution for Operation in Low Power Status

In the low power status, the Manipulator operates at low speed and low torque. However, comparatively high torque as shown in the table below may be generated to support the Manipulator’s own weight. Carefully operate the Manipulator since it may get your hands or fingers caught during operation. The Manipulator may also collide with peripheral equipment and cause equipment damage to or malfunction of the Manipulator.

**Maximum joint output torque in low power status [Unit: N·m]**

Joint		#1	#2	#3	#4	#5	#6
Joint Torque	CX7-A701\ ***	51.00	160.27	86.70	32.89	32.72	19.71
	CX7-A701***W	188.71					
	CX7-A901\ ***	63.59	245.71	110.57	32.89	32.72	19.71
	CX7-A901***W	263.92					

**⚠ CAUTION**

- Carefully operate the Manipulator in the low power status. A comparatively high joint torque may be generated. It may cause your hands and fingers caught and/or cause equipment damage to or malfunction of the Manipulator as it may collide with peripheral equipment.

### 3.1.8 Warning Labels

The Manipulator has the following warning labels. Specific hazards exist in the vicinity of areas with the warning labels. Be thoroughly careful in handling. To ensure that the Manipulator is operated and maintained safely, be sure to follow the safety information and warnings indicated on the warning labels. Also, do not tear, damage, or remove these warning labels.

### 3.1.8.1 Warning Labels

A



Touching any internal electrified parts while the power is turned on may cause electric shock.

B



HOT Be careful not to burn yourself.

C



When releasing the brakes, be careful of the arm falling due to its own weight.

This warning label is attached on the Manipulator and optional brake release unit as well.

When the brake release unit is used:

When using a brake release unit to release brakes, refer to the following section.

[How to Move Arms with the Electromagnetic Brake](#)

### 3.1.8.2 Information Labels

1

This indicates the product name, model name, serial number, information of supported laws and regulations, product specifications (Weight, MAX.REACH, MAX.PAYLOAD, AIR PRESSURE, Motor Power), Main document No., manufacturer, importer, date of manufacture, country of manufacture, and the like.

For details, see the label affixed to the product.

2



This indicates the position for mounting eyebolts. Refer to the following section for examples of using eyebolts.

## Environment and Installation

### Location of Labels

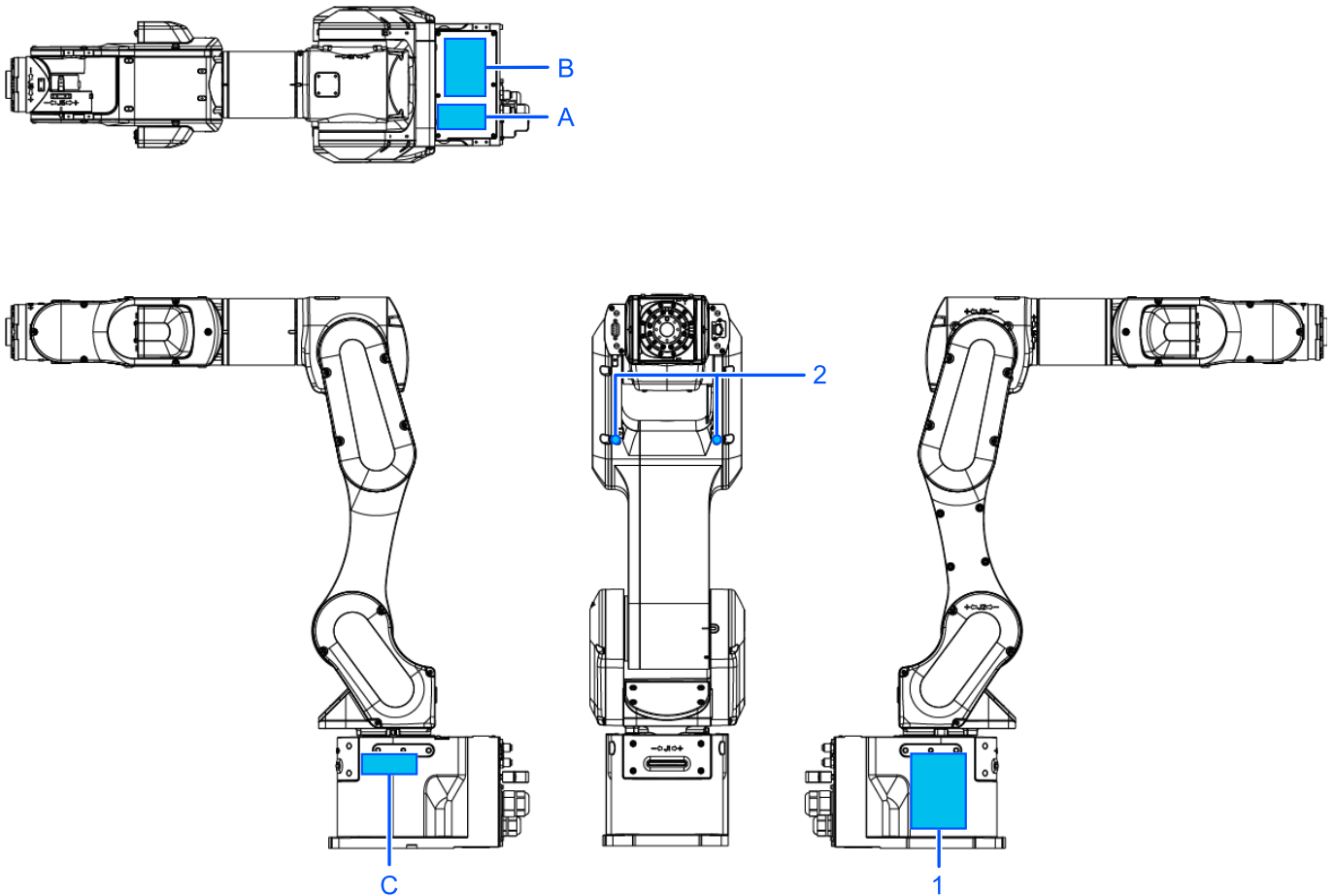

## 3.1.9 Responses for Emergencies or Malfunctions

### 3.1.9.1 When a Collision with the Manipulator Occurs

If the Manipulator has collided with a mechanical stop, peripheral device, or other object, discontinue use and contact the supplier.

Also, if the Manipulator collides with mechanical stops or peripheral devices, the following problems may occur.

- Reduction of the life and damage of the reduction gear unit
- Position gap at the joints

### 3.1.9.2 Entanglement with the Manipulator

When the operator is caught between the Manipulator and a mechanical part such as a base table, press the emergency stop switch to release the brake on the subject arm, and then move the arm by hand.

#### How to release a brake

- When using a brake release unit, refer to the following section.

#### Brake Release Unit

- When using software, refer to the following section.

#### When using software

## 3.2 Specifications

### 3.2.1 Model Number

CX7 - A 7 0 1 S

[a]
[b]
[c]
[d]
[e]

- a: Arm length
  - 7: 700 mm (Model name: CX7)
  - 9: 900 mm (Model name: CX7L)
- b: Brake equipment
  - 1: Brakes on all joints
- c: Environment
  - S: Standard \*1
  - C: Cleanroom & ESD (anti-static) \*1
  - P: Protection \*2
- d: Mounting type
  - : Table top mounting
  - R: Ceiling mounting \*2
  - W: Wall mounting 2
- e: Internal wiring
  - : Available
  - -NIW: Not available

\*1 Equivalent to IP20

\*2. IP67

\*3 Manipulators are set to "Table Top mounting" or "Wall mounting" at shipment. To use the Manipulators as "Ceiling mounting", you need to change the model settings.

- **Changing the Robot**
- "Epson RC+ User's Guide - Robot Configuration"

### 3.2.2 Part Names and Motion Range of Each Arm

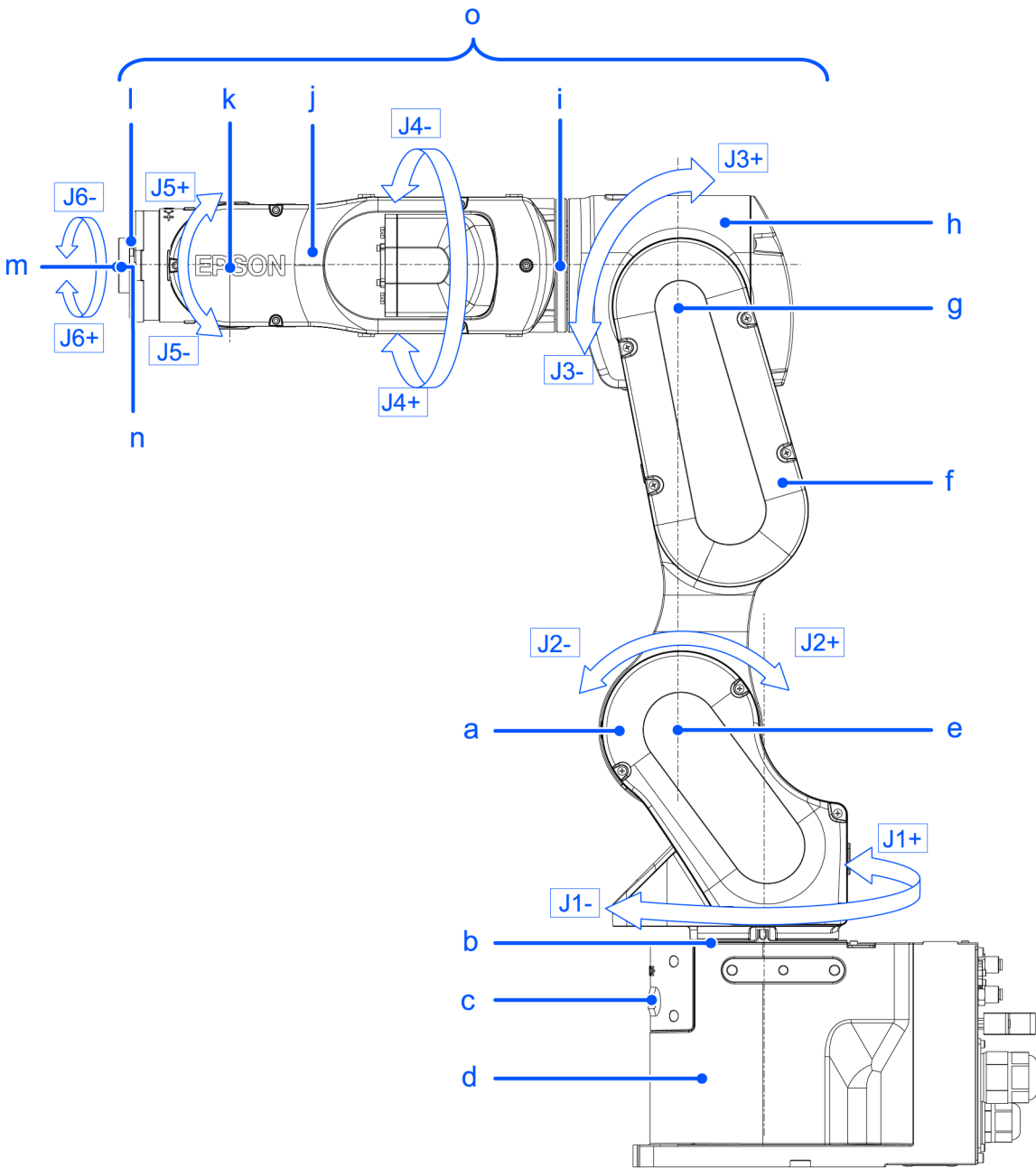

Symbol	Description
a	Arm #1 (Lower Arm)
b	Joint #1 (The whole Manipulator revolves.)
c	LED Lamp (This lamp lights up while the motors are on.)
d	Base
e	Joint #2 (The lower arm swings.)
f	Arm #2
g	Joint #3 (The upper arm swings.)
h	Arm #3

Symbol	Description
i	Joint #4 (The wrist revolves.)
j	Arm #4
k	Joint #5 (The wrist swings.)
l	Arm #5
m	Arm #6
n	Joint #6 (The hand rotates.)
o	Upper Arm (Arms #3 to #6)

 **KEY POINTS**

When the LED lamp is lighting or the Controller power is on, the current is being applied to the Manipulator. (The LED lamp may not be seen depending on the Manipulator's posture. Be thoroughly careful. Performing any work procedure with the power turned on is extremely dangerous and may result in electric shock and/or malfunction of the robot system. Before starting any maintenance work, be sure to turn off the Controller.

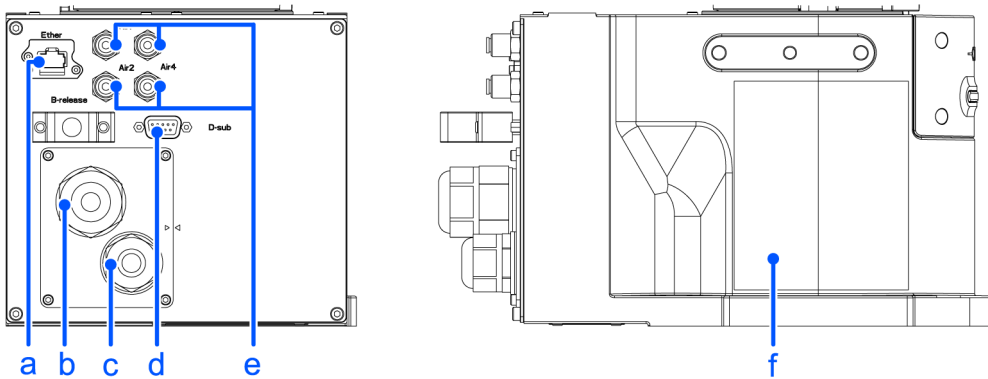

Symbol	Description
a	User cable connector (Ethernet connector)
b	Power cable
c	Signal cable
d	User cable connector (9-pin D-sub connector)
e	Fitting for $\varnothing 4$ mm tube
f	Face plate (serial number of Manipulator)

### 3.2.3 Outer Dimensions

#### 3.2.3.1 CX7-A701\*\*\*

(Units: mm)

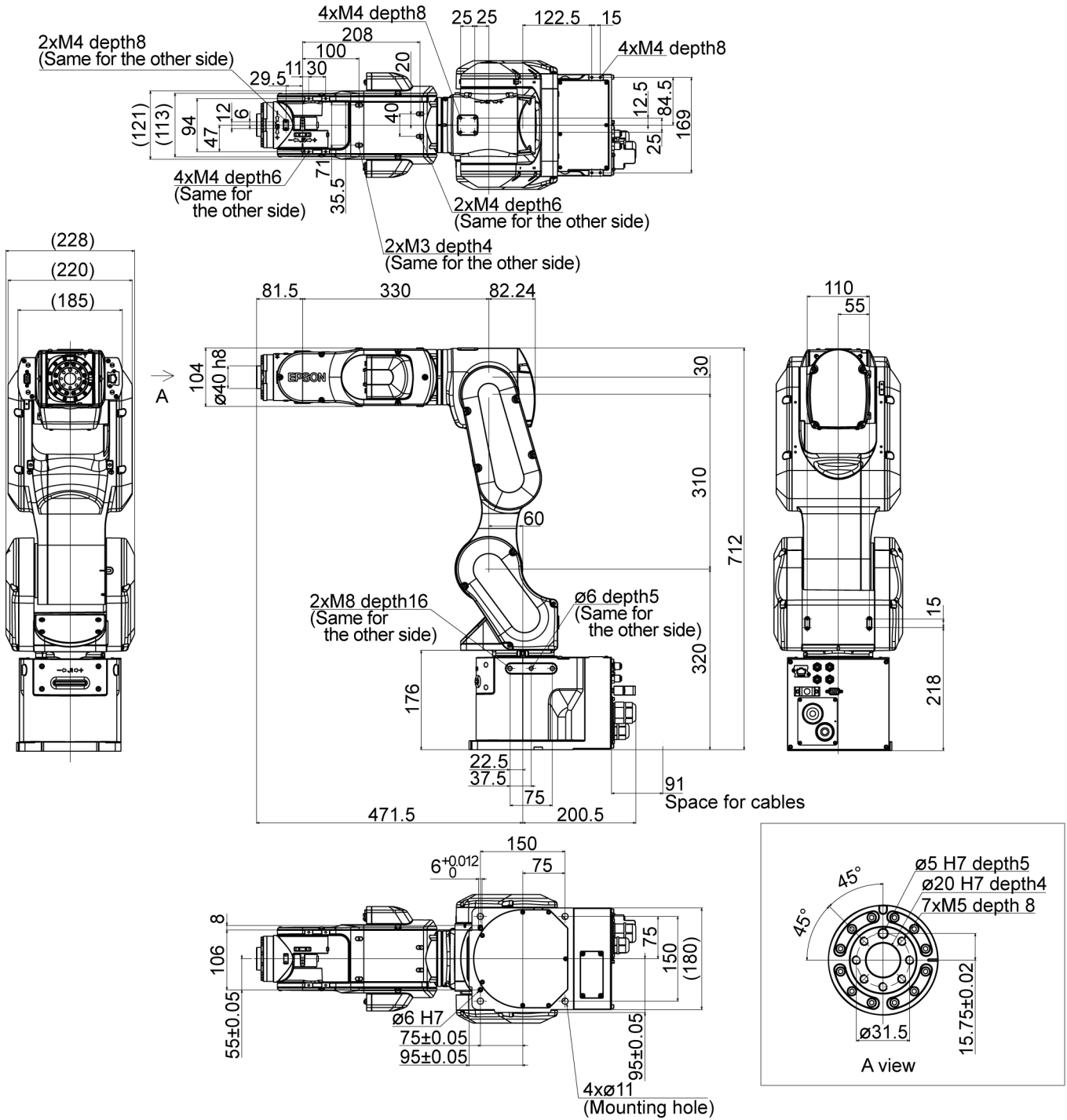

**3.2.3.2 CX7-A901\*\*\***

(Units: mm)

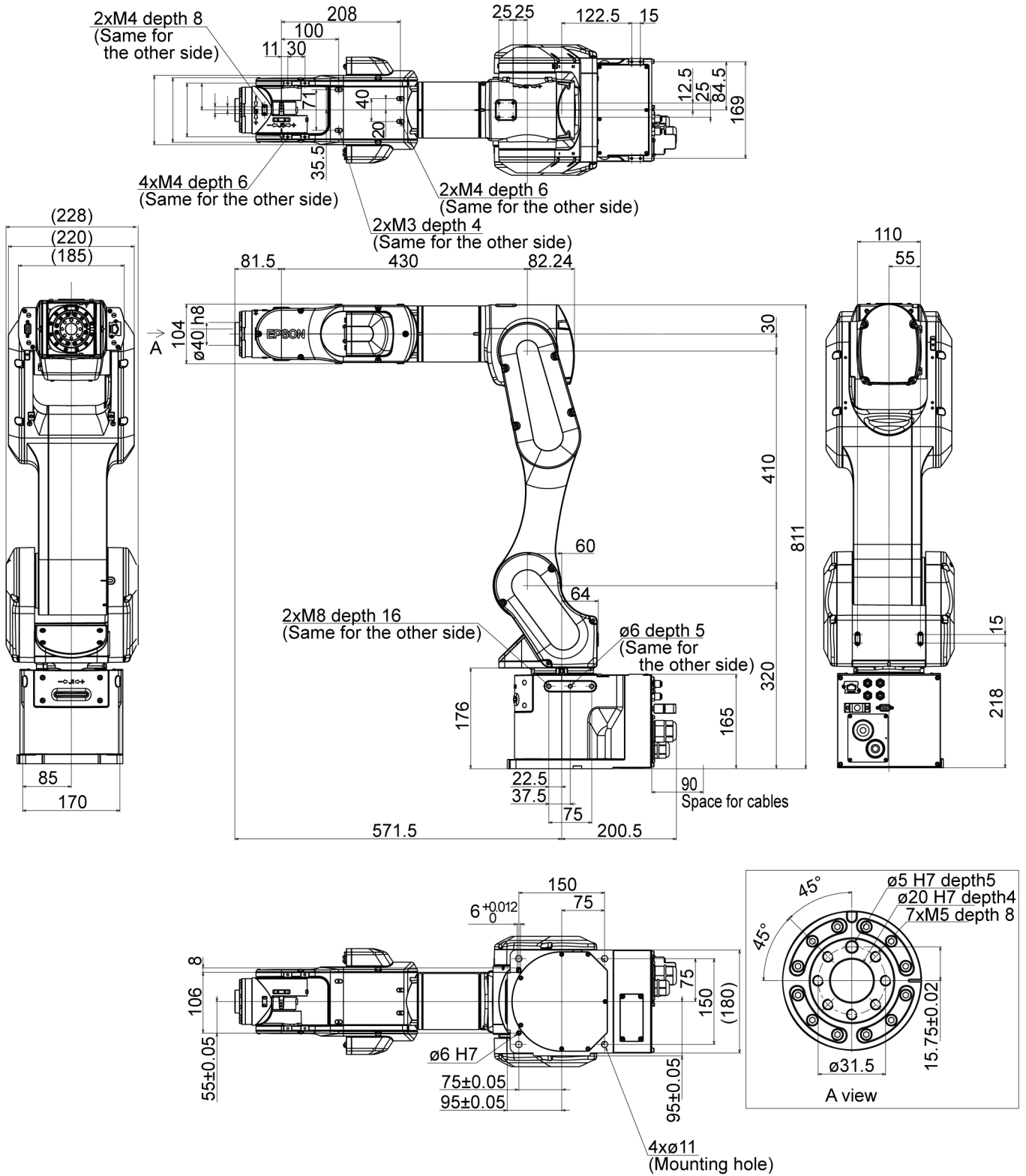

### 3.2.4 Standard Work Envelope

#### 3.2.4.1 CX7-A701\*\*\*

(Units: mm)

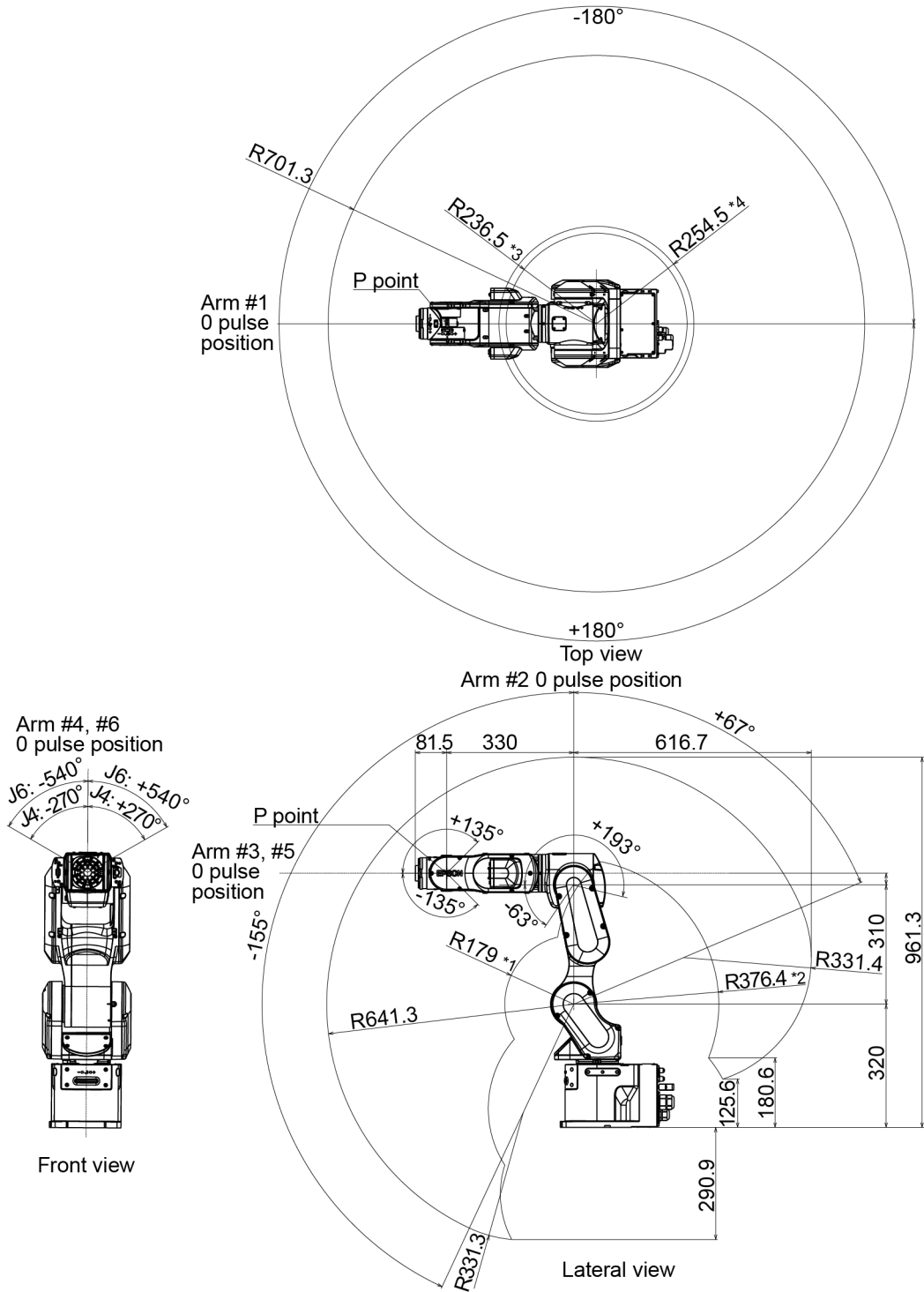

(deg. = °)

\*P point: Intersection of the rotation centers for Joint #4, #5, and #6

\*1: P point from lateral with Joint #3 declining -63° (Joint #2 center – P point center)

\*2: P point from lateral with Joint #3 declining +193° (Joint #2 center – P point center)

\*3: P point from top with Joint #3 tilting up  $-63^{\circ}$  (Joint #1 center – P point center)

\*4: P point from top with Joint #3 tilting up  $+193^{\circ}$  (Joint #1 center – P point center)

### CAUTION

- Pay attention to the arm pose of the basic arms (Arms #1, #2, and #3) when operating the Manipulator. Arm #5 moves keeping a constant angle regardless of the arm pose. Depending on the arm pose of the basic arms, the wrist may collide with the Manipulator. The collision may cause equipment damage to and/or malfunction of the Manipulator.

### 3.2.4.2 CX7-A901\*\*\*

(Units: mm)

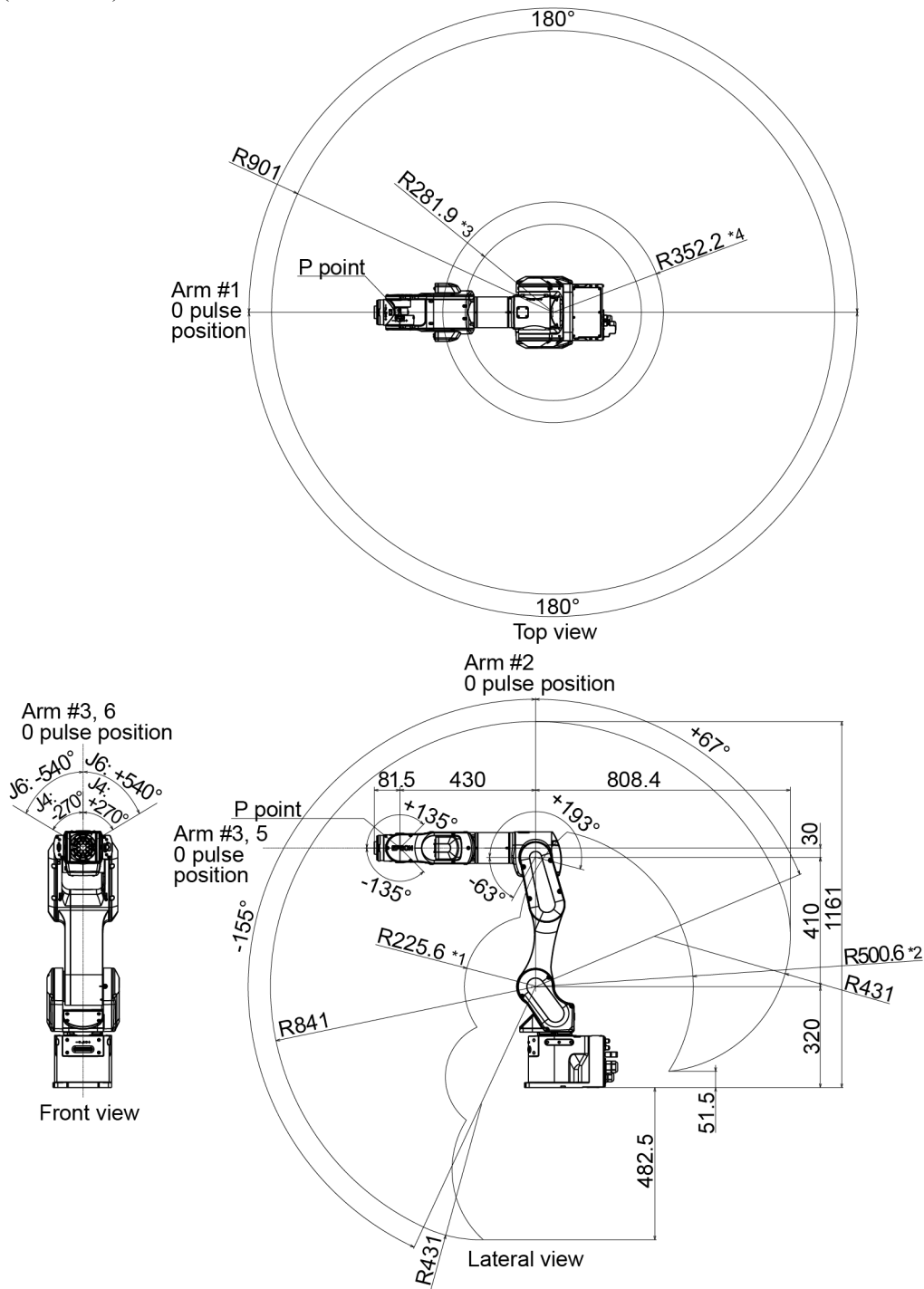

(deg. = °)

\*P point: Intersection of the rotation centers for Joint #4, #5, and #6

\*1: P point from lateral with Joint #3 declining -63° (Joint #2 center – P point center)

\*2: P point from lateral with Joint #3 declining +193° (Joint #2 center – P point center)

\*3: P point from top with Joint #3 tilting up  $-63^{\circ}$  (Joint #1 center – P point center)

\*4: P point from top with Joint #3 tilting up  $+193$  (Joint #1 center – P point center)

### CAUTION

- Pay attention to the arm pose of the basic arms (Arms #1, #2, and #3) when operating the Manipulator. Arm #5 moves keeping a constant angle regardless of the arm pose. Depending on the arm pose of the basic arms, the wrist may collide with the Manipulator. The collision may cause equipment damage to and/or malfunction of the Manipulator.

## 3.2.5 Specifications

### 3.2.5.1 Specifications Table

For the specifications tables of each model, refer to the following section.

[CX7 Specifications](#)

### 3.2.5.2 Options

For details, refer to the following section.

[Options](#)

## 3.2.6 How to Set the Model

The Manipulator model for your system has been set before shipment from the factory.

### CAUTION

- If changing the setting of the Manipulator model, be responsible and absolutely certain that the wrong Manipulator model is not set. Incorrect setting of the Manipulator model may result in abnormal or no operation by the Manipulator and could even cause safety problems.

If a custom specifications number (MT\*\*\*) or (X\*\*\*) is written on the face plate (serial number label), the Manipulator has custom specifications.

Models with custom specifications may require a different setting procedure. Check the custom specifications number, and contact the supplier for more information.

The Manipulator model is set from software. For details, refer to the following manual.

"Epson RC+ User's Guide - Robot Configuration"

## 3.3 Environment and Installation

The robot system should be designed and installed by people who have received installation training provided by Epson and the suppliers. Also, the laws and regulations of the installation country must be followed.

### 3.3.1 Environment

To ensure that the robot system operates and maintains maximum performance and to ensure its safe use, the robot system should be installed in an environment that meets the following requirements.

Item	Conditions
Ambient temperature *	Installation: 5 to 40°C Transport, storage: -20 to 60°C
Ambient relative humidity	Installation: 10 to 80% (no condensation) Transport, storage: 10 to 90% (no condensation)
Fast transient burst noise	1 kV or less (signal line)
Electrostatic noise	4 kV or less
Altitude	1000 m or less

\* The ambient temperature requirement is for the Manipulator only. For details on the environment requirements for the connected Controller, refer to the Robot Controller manual.

 **KEY POINTS**

---

When used in a low-temperature environment near the minimum temperature specified in the product specifications, or when the unit is idle for a long period of time during holidays or at night, a collision detection error or similar error may occur immediately after the start of operation due to high resistance in the drive unit. In such cases, warm-up operation for about 10 minutes is recommended.

 **KEY POINTS**

---

If there are conductive objects such as fences or ladders within 2.5 m of the Manipulator, these objects must be grounded.

Also, depending on the environmental specifications of the Manipulator, the following requirements must be met.

Environmental Specifications	Conditions
S, C, P	<ul style="list-style-type: none"> <li>- Install indoors.</li> <li>- Keep away from direct sunlight.</li> <li>- Keep away from shocks or vibrations.</li> <li>- Keep away from sources of electric noise.</li> <li>- Keep away from explosive areas.</li> <li>- Keep away from large quantities of radiation.</li> </ul>
S, C	<ul style="list-style-type: none"> <li>- Keep away from dust, oily smoke, salinity, metal powder, and other contaminants.</li> <li>- Keep away from flammable or corrosive liquids and gases.</li> <li>- Keep away from organic solvents, acids, alkalis, and chlorine cutting fluids.</li> <li>- Keep away from water.</li> </ul>

The following items should also be taken into consideration for the installation environment of Manipulators with protected-models.

- These are compliant with the IP67 protection class (IEC 60529, JIS C0920). The Manipulators can be used in environments where the possibility of dust, water, and water-soluble cutting oil falling of the Manipulator exists.
- They can be installed in environments where dust, oil smoke, metal powder, and similar substances are airborne, but they are not suitable for use with nitrile rubber oil seals, O-rings, packings, liquid gaskets, or other substances that impair sealing performance.
- The Manipulator cannot be used in environments exposed to liquids or airborne droplets that are corrosive such as acids or alkalis.
- In environments that are exposed to airborne droplets containing salt, rust may also form on the Manipulator.
- Manipulator surfaces are generally oil-resistant, but if special oils are to be used, oil resistance should be checked before use. For more information, please contact the supplier.
- In environments with rapid changes in temperature and humidity, condensation may form inside the Manipulator.
- When handling food directly, it is necessary to make sure that the Manipulator is not likely to contaminate the food. For more information, please contact the supplier.
- The Controllers used with Manipulators with protected-models do not have protection against harsh environments. The Controller should be installed in a location that meets its operating environment requirements.



## KEY POINTS

If the Manipulator will be used in a location that does not meet the above requirements, please contact the supplier.



## WARNING

- Always use a circuit breaker for the Controller's power supply. Failure to use a circuit breaker may result in an electrical shock hazard or malfunction due to an electrical leakage. Select the correct circuit breaker based on the Controller that you are using. For details, refer to the following manual.

"Robot Controller Manual"



## CAUTION

- When cleaning the Manipulator, do not rub it strongly with alcohol or benzene. Coated surfaces may lose their luster.

## 3.3.2 Manipulator Mounting Dimensions

### Mounting Area

Also, besides the area required for installation of the Manipulator, Controller, peripheral equipment, and other devices, the following space should be provided at a minimum.

- Space for teaching
- Space for maintenance and inspections (for installing jigs and working safely within the safety barriers)
- Space for cables

### KEY POINTS

- When installing the cables, be sure to maintain sufficient distance from obstacles.
- For the minimum bend radius of the M/C cable, refer to the following section.  
[CX7 Specifications](#)
- Also, leave enough space for other cables so that they are not forced to bend at extreme angles.

**CX7-A701\*\*\***

(Units: mm)

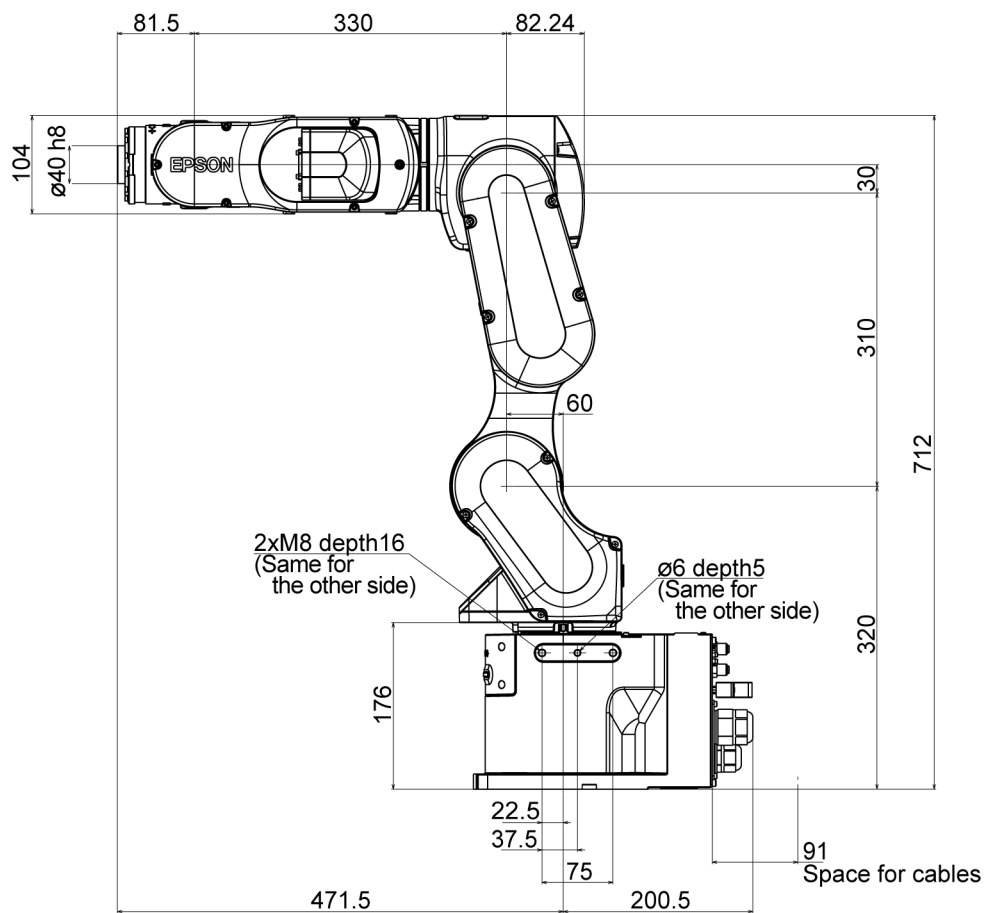

depth = depth of threaded hole

**CX7-A901\*\*\***

(Units: mm)

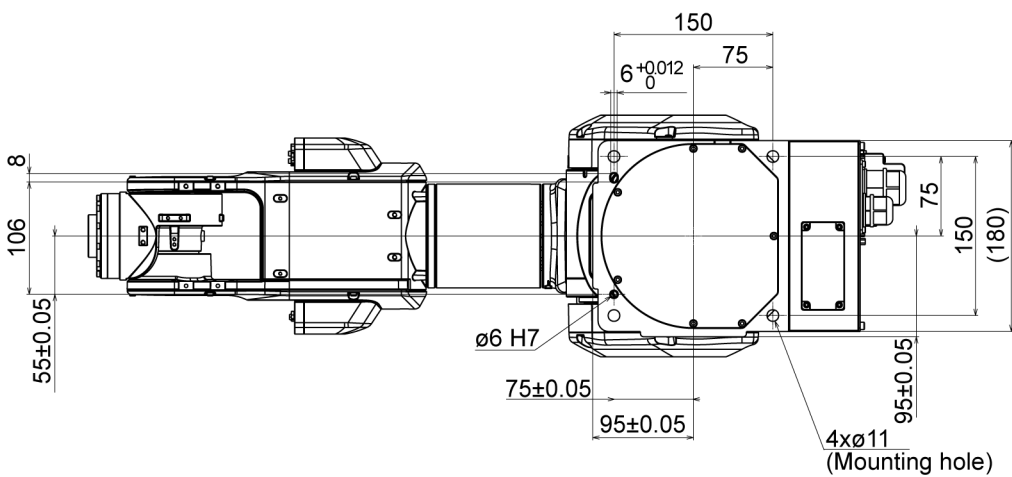
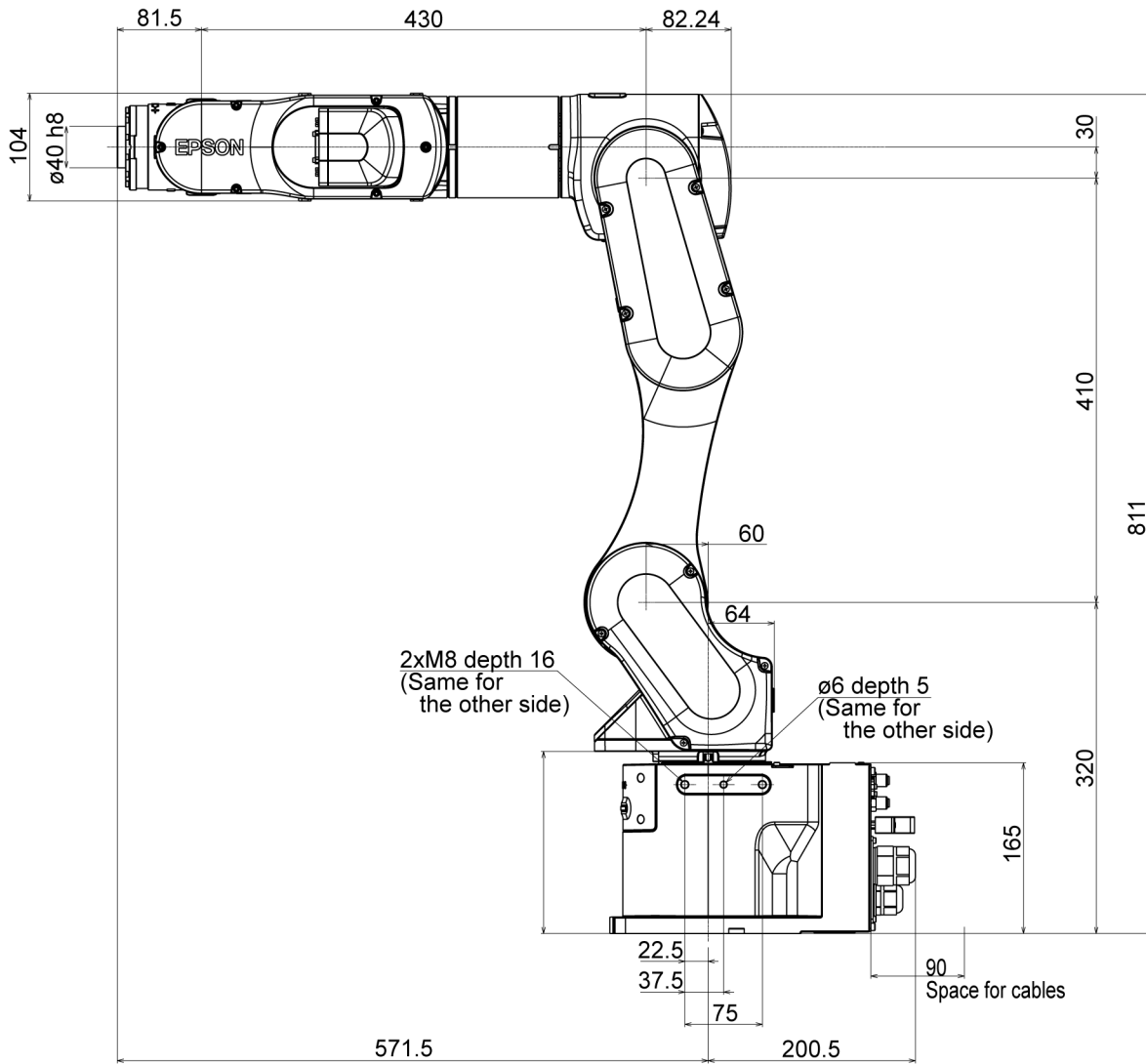

depth = depth of threaded hole

### 3.3.3 From Unpacking to Installation

Transportation and installation of the Manipulator and related equipment should be performed by people who have received installation training provided by Epson and the suppliers. Also, the laws and regulations of the installation country must be followed.

#### WARNING

- Only qualified personnel should perform sling work and operate a crane or a forklift. When these operations are performed by unqualified personnel, it is extremely hazardous and may result in serious bodily injury and/or severe equipment damage to the robot system
- When hoisting the Manipulator, use your hands to balance it. Losing balance may cause the Manipulator to drop, which is extremely hazardous and may result in serious injury and/or severe damage to the robot system.
- To ensure safety, be sure to install safeguards for the robot system. For more information on safeguards, refer to the following manual.  
"Epson RC+ User's Guide - Safety - Installation and Design Precautions "
- Install the Manipulator in a location with sufficient space so that a tool or a work piece does not touch a wall or a safeguard when the Manipulator extends its arm fully while holding a work piece. If the tool or the workpiece tip reaches a wall or safeguards, it is extremely hazardous and may result in serious bodily injury and/or severe equipment damage to the robot system.
- Be sure to anchor the Manipulator before turning on the power or operating it. Turning on the power or operating the Manipulator while it is not anchored may cause the Manipulator to fall over, which is extremely hazardous and may result in serious injury and/or severe damage to the robot system.
- Before installing or operating the Manipulator, make sure that no parts of the Manipulator are missing and that it has no damage or other external defects. Missing parts or damage may cause malfunction of the Manipulator, is extremely hazardous, and may result in serious injury and/or severe equipment damage to the robot system.

#### CAUTION

- Use a cart or the like to transport the Manipulator in the same status as it was delivered.
- When removing the fixing bolts securing the Manipulator to the transportation pallet and the packing box or the anchor bolts, support the Manipulator to prevent it falling. Removing the fixing bolts or anchor bolts without supporting the Manipulator may cause it to fall, catching your hands or feet.
- The Manipulator should be transported by two or more people or secured to transporting equipment. Also, do not hold the bottom of the base (the screened parts in the figure). Holding these parts by hand is extremely hazardous and may cause your hands and fingers caught.

- CX7-A701\*\*\*

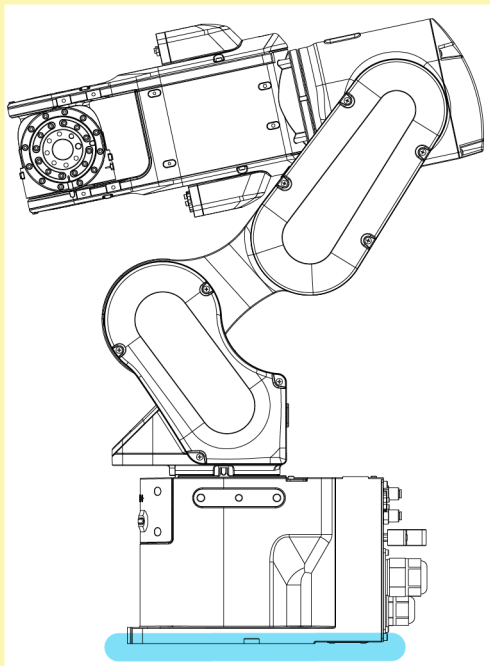

- CX7-A901\*\*\*

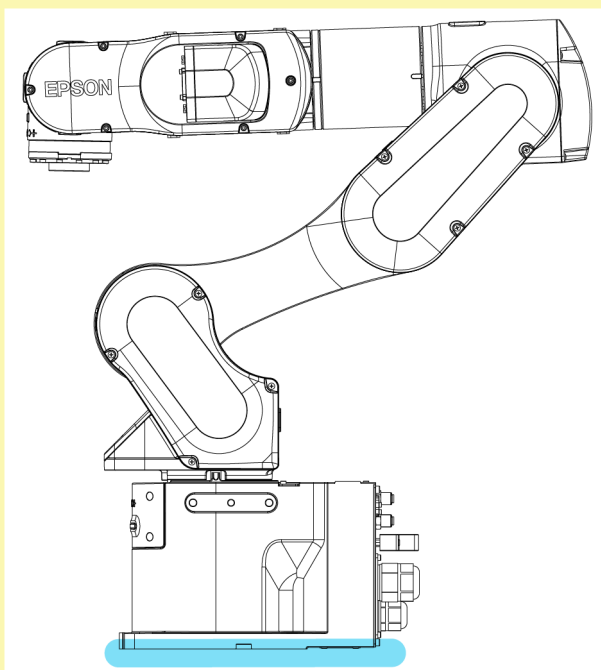

Manipulator weight

	CX7-A701\ ***	CX7-A901***
Standard(- NIW) cleanroom(- NIW ) specifications	32 kg: 70.5 lb	33 kg: 72.8 lb
Standard, cleanroom specification, Protected (- NIW) Model	33 kg: 72.8 lb	35 kg: 77.2 lb
Protected-Model	34 kg: 75.0 lb	36 kg: 79.4 lb

- Take extra care when transporting the Manipulator. You may hit and damage the connector.



- During unpacking and relocation, avoid applying external force to the arms and motors of the Manipulator.
- When transporting the Manipulator over long distances, secure it directly to transporting equipment so that it will not fall. If necessary, pack the Manipulator using the same packaging as delivery.
- The Manipulator must be installed to avoid interference with surrounding buildings, structures, and other machines and equipment that may create a trapping hazard or pinch points.
- Resonance (resonating sound or minute vibrations) may occur during Manipulator operation depending on the rigidity of the base table. If the resonance occurs, improve the rigidity of the base table or change the speed or acceleration and deceleration settings of the Manipulator.

**Protective tape**

Remove the protective tape (4 places).

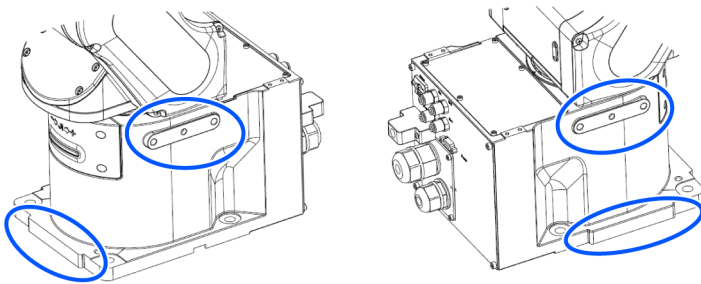

**Fixing bolt**

For details on the dimensions, refer to the following sections.

**Manipulator Mounting Dimensions**

There are four threaded holes for the Manipulator base. Use M12 mounting bolts conforming to the strength equivalent to ISO898-1 property class 10.9 or 12.9.

Tightening torque: 100.0 ± 5.0 N·m (1,020 ± 51 kgf·cm)

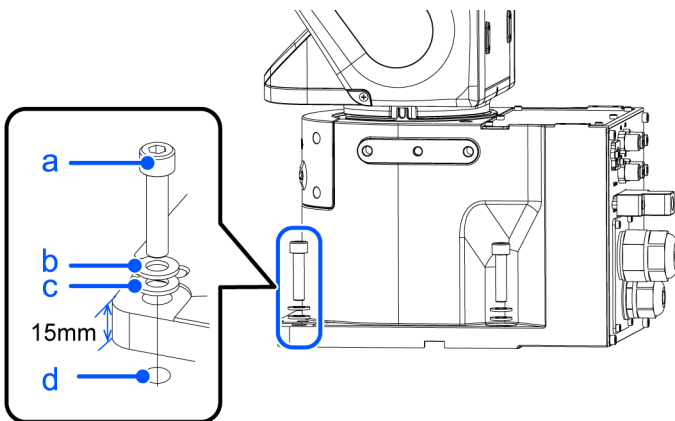

Symbol	Description
a	4×M8×35

Symbol	Description
b	4×Spring washer
c	4×Plain washer
d	Threaded hole (20 mm or more depth)

### Base table

A base table for anchoring the Manipulator is not supplied. The base table must be fabricated or obtained by the customer.

The shape and size of the base table vary depending on the application of the robot system. As a reference when designing the base table, the requirements from the Manipulator side are shown here.

The base table must not only be able to bear the weight of the Manipulator but also be able to withstand the dynamic movement of the Manipulator when it operates at maximum acceleration/deceleration. Ensure that there is enough strength on the base table by attaching reinforcing materials such as crossbeams.

Followings are the torque and reaction force produced by the movement of the Manipulator.

Model Number	CX7-A701\ ***	CX7-A901***
Maximum rotating torque on horizontal surface (N·m)	460	550
Maximum reaction force in horizontal direction (N)	1100	970
Maximum rotating torque on vertical surface (Nm)	810	990
Maximum reaction force in vertical direction (N)	2100	1800

### CAUTION

If the vibration of the base table is large, reduce the acceleration/deceleration or increase the rigidity of the base table to reduce the vibration. Continued use in a state of large vibration may cause loosening of fastening parts or excessive load on mechanical parts, which may shorten the lifespan.

The plate for the Manipulator mounting face should be at least 30 mm thick and made of steel for reducing vibrations.

A surface roughness of 25  $\mu\text{m}$  or less at the maximum height is appropriate.

The base table must be secured on the floor to prevent it from moving.

The Manipulator installation surface should have a flatness of 0.5 mm or less and an inclination of 0.5° or less. If the installation surface does not have the proper flatness, the base of the Manipulator may be damaged or the robot may be unable to operate at maximum performance.

When using a leveler to adjust the height of the base table, use a screw with M16 diameter or more.

### Connector

If passing cables through the holes in the base table, refer to the connector dimensions in the figures below. (Units: mm)

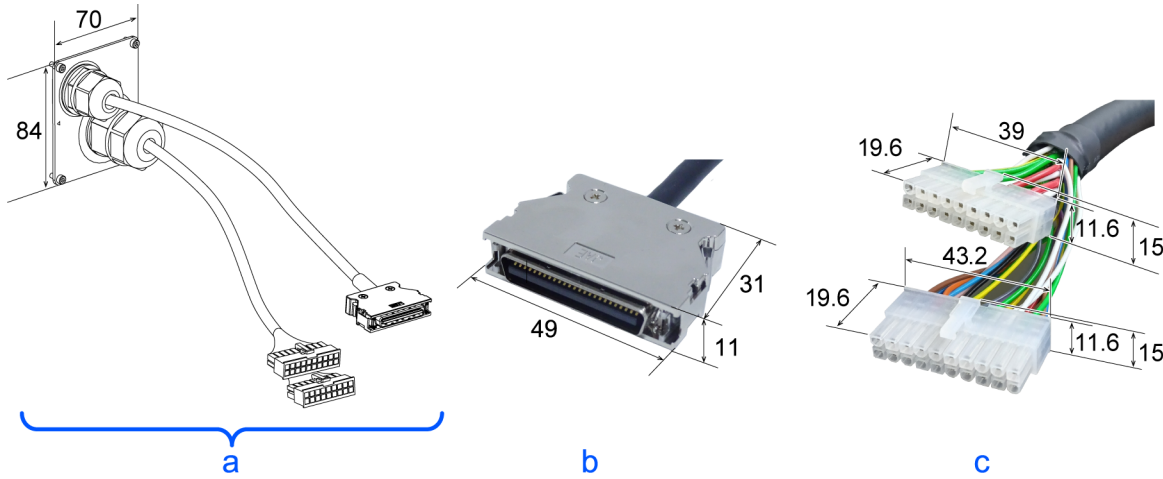

Symbol	Description
a	M/C cable
b	Signal cable connector
c	Power cable connector

Do not remove the M/C cables from the Manipulator.

**KEY POINTS**

For details on the environmental requirements for the space when housing the Controller in the base table, refer to the Robot Controller manual.

When using the Manipulator in the clean room, follow the steps below before the installation.

1. Unpack the Manipulator outside of the cleanroom.
2. Secure the Manipulator to transporting equipment (or a pallet) with bolts so that the Manipulator does not fall down.
3. Wipe off any dust on the Manipulator using a lint-free cloth that was dipped in ethyl alcohol or distilled water.
4. Carry the Manipulator into the cleanroom.
5. Secure the Manipulator to the base table.

**3.3.4 Connecting the Cables**

**WARNING**

- Before performing any replacement work, turn off the Controller and related equipment, and unplug the power cable from the power source. Performing any work procedure with the power turned on is extremely dangerous and may result in electric shock and/or malfunction of the robot system.
- Be sure to connect the AC power cable to a power outlet. Do not connect it directly to a factory power source. To perform the power supply lockout, remove the power plug. Working while connecting the AC power cable to a factory power source may result in electric shock and/or malfunction of the robot system.
- Be sure to connect the cables properly. Do not put heavy objects on the cables, bend or pull on the cables forcibly, or allow the cables to be pinched. Damaged cables, broken wires, or contact failure is extremely hazardous and may result in electric shock and/or malfunction of the robot system.

- Be sure to turn off the power and tag out (e.g., with a "DO NOT TURN ON" sign) before performing wiring. Performing any work procedure with the power turned on is extremely dangerous and may result in electric shock and/or malfunction of the robot system.
- The Manipulator is grounded by connecting it to the Controller. Ensure that the Controller is grounded and the cables are correctly connected. If the ground wire is improperly connected to ground, it may result in the fire or electric shock.
- Turn off the power to the Robot Controller and brake release unit when connecting or replacing the brake release unit or external short connector. Inserting or removing connectors with the power on may result in electric shock and/or malfunction of the robot system.

### CAUTION

- When connecting the Manipulator and the Controller, check that the serial numbers match for each device. Improper connection between the Manipulator and the Controller may not only lead to malfunction of the robot system but also safety problems. The connection method between the Manipulator and the Controller varies depending on the Controller. For details on the connection, refer to the following manual.

"Robot Controller Manual"

- Only authorized or certified personnel should perform wiring. Wiring by unauthorized or uncertified staff may result in bodily injury and/or malfunction of the robot system.
- Operating the Manipulator without a brake release unit or external short connector connected may cause the brake to fail to release, possibly damaging the brake.

After using the brake release unit, be sure to connect the external short circuit connector to the Manipulator or make sure to leave the connector for the brake release unit connected.

### **Cleanroom-model Manipulator**

When the Manipulator is a model with cleanroom specifications, an exhaust system must be connected. For the exhaust system, refer to the following section.

#### [CX7 Specifications](#)

### **Protected-model Manipulator**

When the Manipulator is a protected-model, please note the following points.

### CAUTION

- When operating Manipulators in special environments (oil smoke, dust, etc.), do not install the Controller in the same environment. The Controller does not satisfy the protection class (IP67). Using the Controller in these special environments may damage or lead to a breakdown of the Controller.
- After using the brake release unit, be sure to reconnect the external short connector to the Manipulator. The break release unit does not satisfy the protection class (IP67).
- Be sure to connect a connector compliant with protection class IP67 or higher and a connector cover to the Ethernet cable connector.

### **Connection procedure for M/C cable**

Connect the power connector and signal connector of the M/C cable to the Controller.

### 3.3.5 User Wires and Pneumatic Tubes

**⚠ CAUTION**

- Only authorized or certified personnel should perform wiring. Wiring by unauthorized or uncertified staff may result in bodily injury and/or malfunction of the robot system.

User electrical wires and pneumatic tubes are contained in the cable unit.

#### Electrical Wires

- Specifications of the user wires D-sub 15-pin

Rated Voltage	Allowable Current	Wires	Nominal Sectional Area	Note
AC/DC30V	1 A	15	0.106 mm <sup>2</sup>	Shielded

Pins with the same number, indicated on the connectors on both ends of the cables, are connected.

- Attached connector for user wires (standard, cleanroom model)

		Manufacturer	Type	
15 pin	Connector	JAE	DA-15PF-N	(Solder type)
	Clamp hood	HRS	HDA-CTH (4-40) (10)	(Connector setscrew: # 4- 40 UNC)

Two parts are attached for each.

- Attached connector for user wires (protected-model)

		Manufacturer	Type	
15 pin	Connector	HARTING	09 67 015 5615	(Solder type)
	Clamp hood	HARTING	09 67 015 0538	(Connector setscrew: # 4- 40 UNC)

Two parts are attached for each.

- 8-pin (RJ45) equivalent to Cat.5e

An Ethernet cable (commercially available) can be connected to Manipulator models with standard and cleanroom specifications.

For the protected-model, use the following optional part.

User connector kit (IP67 waterproof, for RJ45, 2 pcs)

For details, refer to the following section.

#### Options

#### Pneumatic Tubes

Maximum Working Pressure	Number of Tubes	Outer Diameter × Inner Diameter
0.59 MPa (6 kgf/cm <sup>2</sup> : 86 psi)	2	ø6 mm × ø4 mm

**⚠ CAUTION**

- In special environments (e.g., oil smoke, dust, etc.), the user wires and pneumatic tubes should have protected-model (compliant with protection class IP67). If the user wires and pneumatic tubes not protected-model are connected, the protection class (IP67) cannot be guaranteed, and the Manipulator may be damaged or break down.
- Be sure to attach the cap or plug (attached at the time of shipment) on the user cable connector when not using the user cable connector or the pneumatic tubes. Using the Manipulator without the cap or plug may cause equipment damage to and/or malfunction of the Manipulator as dust or oily smoke gets into the connector.

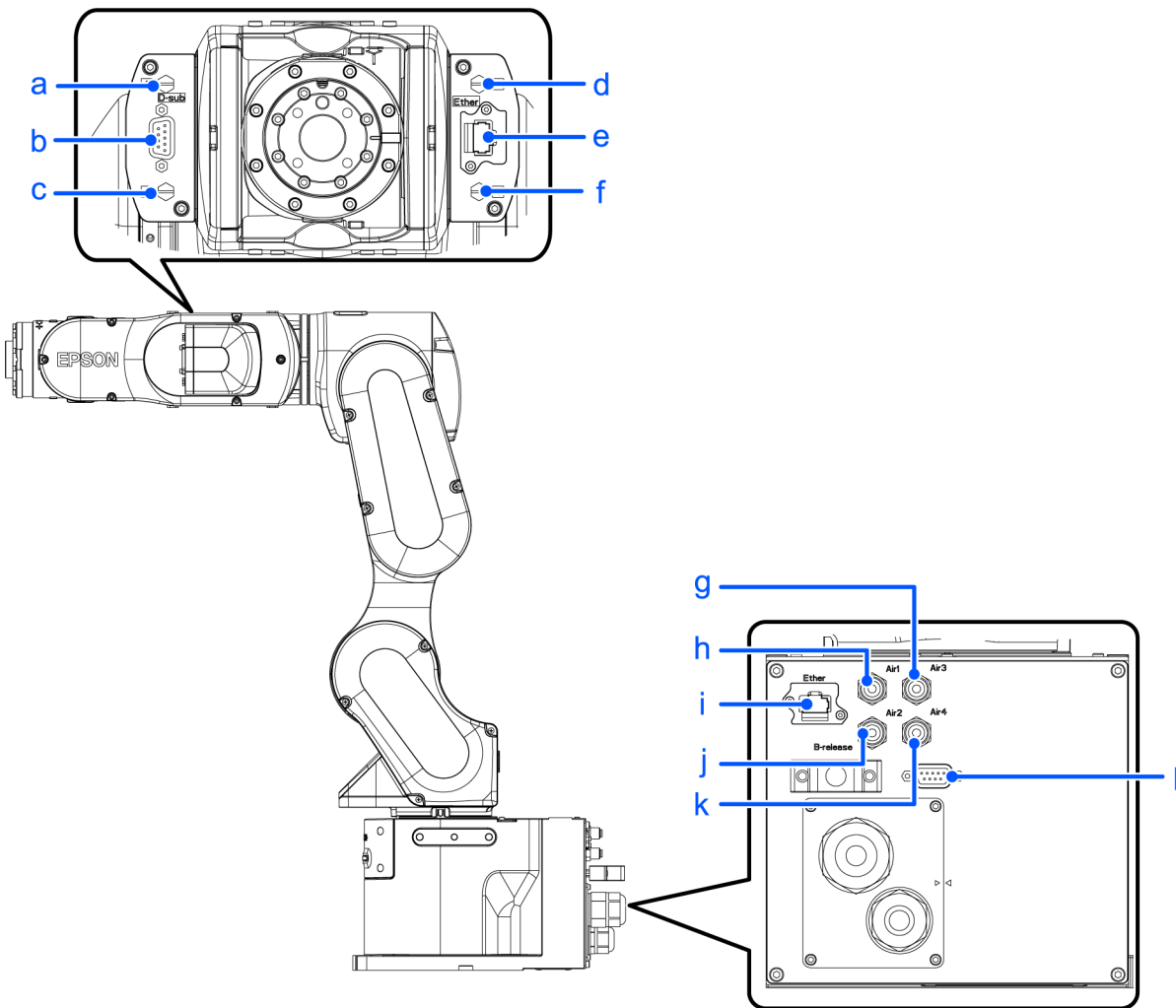

Tubes with the same number are connected.

Symbol	Description
a	No.1
b	User cable connector (9-pin D-sub connector)
c	No.2

Symbol	Description
d	No.3
e	Ethernet cable connector
f	No.4
g	Fitting for ø4 mm tube (Air3)
h	Fitting for ø4 mm tube (Air1)
i	Ethernet cable connector
j	Fitting for ø4 mm tube (Air2)
k	Fitting for ø4 mm tube (Air4)
l	User cable connector (9-pin D-sub connector)

### 3.3.6 Checking the Basic Orientation

After installing the Manipulator and setup the operating environment, check if it moves to the basic position properly.

Follow the steps below to set the basic orientation of the Manipulator shown below as the origin position.

1. Start Epson RC+.  
Double click the [Epson RC+] icon on the desktop.
2. Open the command window.  
Epson RC+ menu-[Tools]-[Command Window]
3. Execute the following command in [Command Window].

```
>Motor On
>Go Pulse (0,0,0,0,0,0)
```

#### KEY POINTS

If "Error 4505: cannot be turned on the motor because the Safety Board is issuing a stop signal." occurs, use one of the following methods to move the Manipulator to its basic orientation.

- Release the brake and push the arm by hand to move it within the motion range. Then follow the steps above.  
For details on releasing brake, refer to the following section.  
[How to Move Arms with the Electromagnetic Brake](#)
- Press the TP4 command button [Pulse0] to move the Manipulator to its basic orientation. For details, refer to the following manual.  
For TP4:  
"Robot Controller Option Teach Pendant TP4 3.2.5.13.2 Command Buttons"  
"Robot Controller Option Teach Pendant TP4 3.2.9.7.2 Command Buttons"

If the Manipulator cannot be in the basic orientation shown below, please contact the supplier.

**CX7-A701\*\*\***

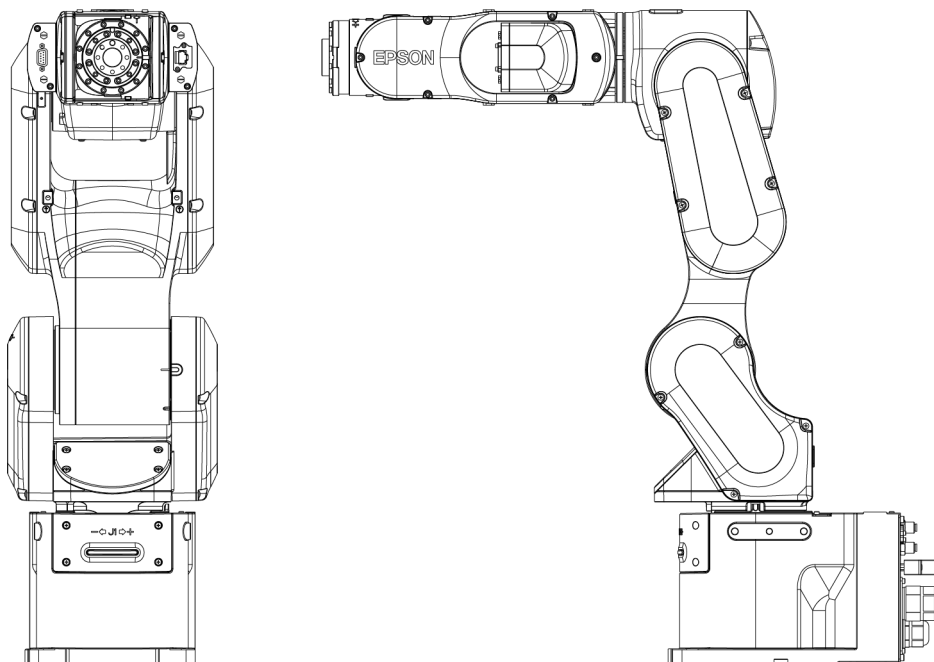

**CX7-A901\*\*\***

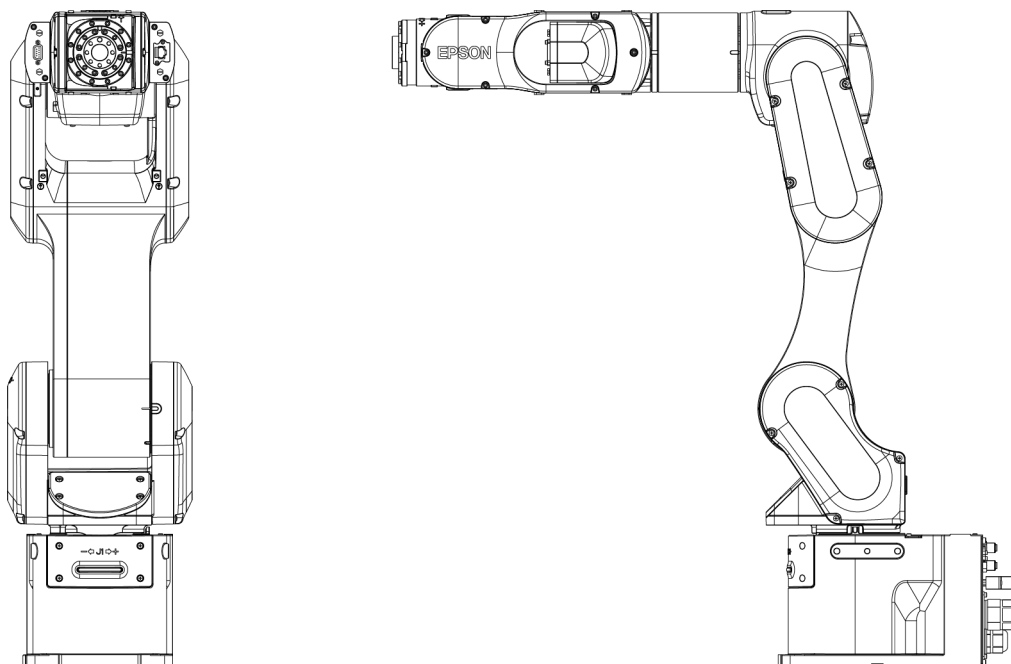

**3.3.7 Relocation and Storage**

**3.3.7.1 Safety Information for Relocation and Storage**

Pay attention to the following requirements when relocating, storing, and transporting the Manipulators.

Transportation and installation of the Manipulator and related equipment should be performed by people who have received installation training provided by Epson and the suppliers. Also, the laws and regulations of the installation country must be followed.

### WARNING

- Only qualified personnel should perform sling work and operate a crane or a forklift. When these operations are performed by unqualified personnel, it is extremely hazardous and may result in serious bodily injury and/or severe equipment damage to the robot system

### CAUTION

- Before relocating, fold the arm and secure it tightly with a cable tie to prevent hands or fingers from getting caught in the Manipulator.
- When removing the anchor bolts, support the Manipulator so that it does not fall. Removing the anchor bolts without supporting the Manipulator can cause it to fall, causing hands or feet to get caught.
- The Manipulator should be transported by two or more people or secured to transporting equipment. Also, do not hold the bottom of the base. Holding these parts by hand is extremely hazardous and may cause your hands and fingers caught.

During unpacking and relocation, avoid applying external force to the arms and motors of the Manipulator.

When transporting the Manipulator over long distances, secure it directly to transporting equipment so that it will not fall. If necessary, pack the Manipulator using the same packaging as delivery.

When the Manipulator is reassembled and used for a robot system again after an extended period of storage, perform a test run to verify that it works properly before starting the main operation.

Manipulators should be transported and stored under the following conditions: Temperature: -20 to +60°C, Humidity: 10 to 90% (no condensation)

If condensation has formed on the Manipulator during transportation or storage, do not turn on the power until the condensation is removed.

Do not subject the Manipulator to excessive impacts or vibrations during the transportation process.

### Relocation

Follow the procedures described below when relocating the Manipulator.

1. Turn off the power for all devices and unplug the power cable connector and signal cable connector from the Controller. Do not remove the M/C cables (power cable and signal cable) from the Manipulator.

### KEY POINTS

Remove the mechanical stops if using them to limit the motion range. For details on the motion range, refer to the following section.

[Setting the Work Envelope by Mechanical Stops](#)

2. Unscrew the anchor bolts. Then, remove the Manipulator from the base table.
3. Position the Manipulator as shown in the figure. Then, secure the Manipulator to the transporting equipment or have at least two people to relocate the Manipulator.

Do not hold the bottom of the base (the screened parts in the figure). Holding these parts by hand is extremely hazardous and may cause your hands and fingers caught.

**CX7-A701\*\*\***

(Recommended: Joint #2 +48°, Joint #3 -60°, Joint #4+90°, Joint #5 -90°)

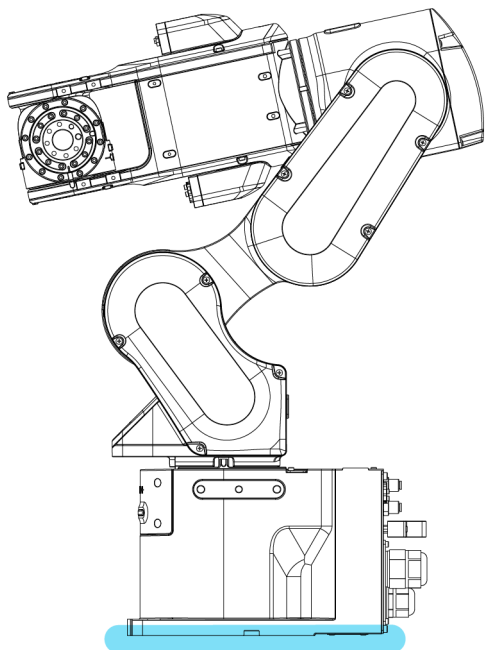

**CX7-A901\*\*\***

(Recommend: Joint #2 +58°. Joint #3 -60°, Joint #5 -87°)

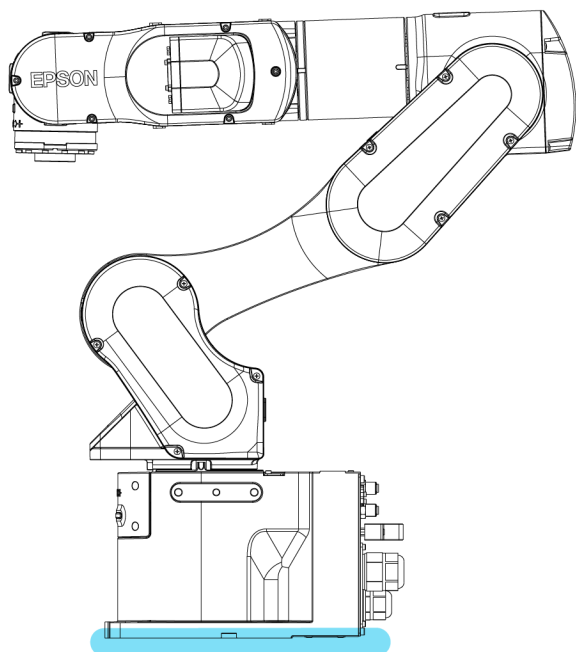

Manipulator weight

	CX7-A701\ ***	CX7-A901***
Standard(- NIW) cleanroom(- NIW ) specifications	32 kg: 70.5 lb	33 kg: 72.8 lb
Standard, cleanroom specification, Protected (- NIW) Model	33 kg: 72.8 lb	35 kg: 77.2 lb
Protected-Model	34 kg: 75.0 lb	36 kg: 79.4 lb

**Using eyebolts**

Check that the eyebolts are securely fastened before transporting the Manipulator. After transporting the Manipulator, remove the eyebolts and keep them for future use.

The eyebolts (accessory, 2 pcs) and wire must be strong enough to withstand the weight (See the figures below).

If you use the eyebolts to lift up the Manipulator, make sure to put hands on it to keep the balance. The Manipulator may fall if the balance is lost and this is extremely hazardous.

To prevent damage on the covers and arms, it is recommended to protect the contacting parts of the wire and arm with a cloth. Be very careful not to damage the covers since they are made of plastic.

**Lifting load**

	CX7-A701\ ***	CX7-A901***
Standard(- NIW) cleanroom(- NIW ) specifications	32 kg: 70.5 lb	33 kg: 72.8 lb
Standard, cleanroom specification, Protected (- NIW) Model	33 kg: 72.8 lb	35 kg: 77.2 lb
Protected-Model	34 kg: 75.0 lb	36 kg: 79.4 lb

**CX7-A701\*\*\***

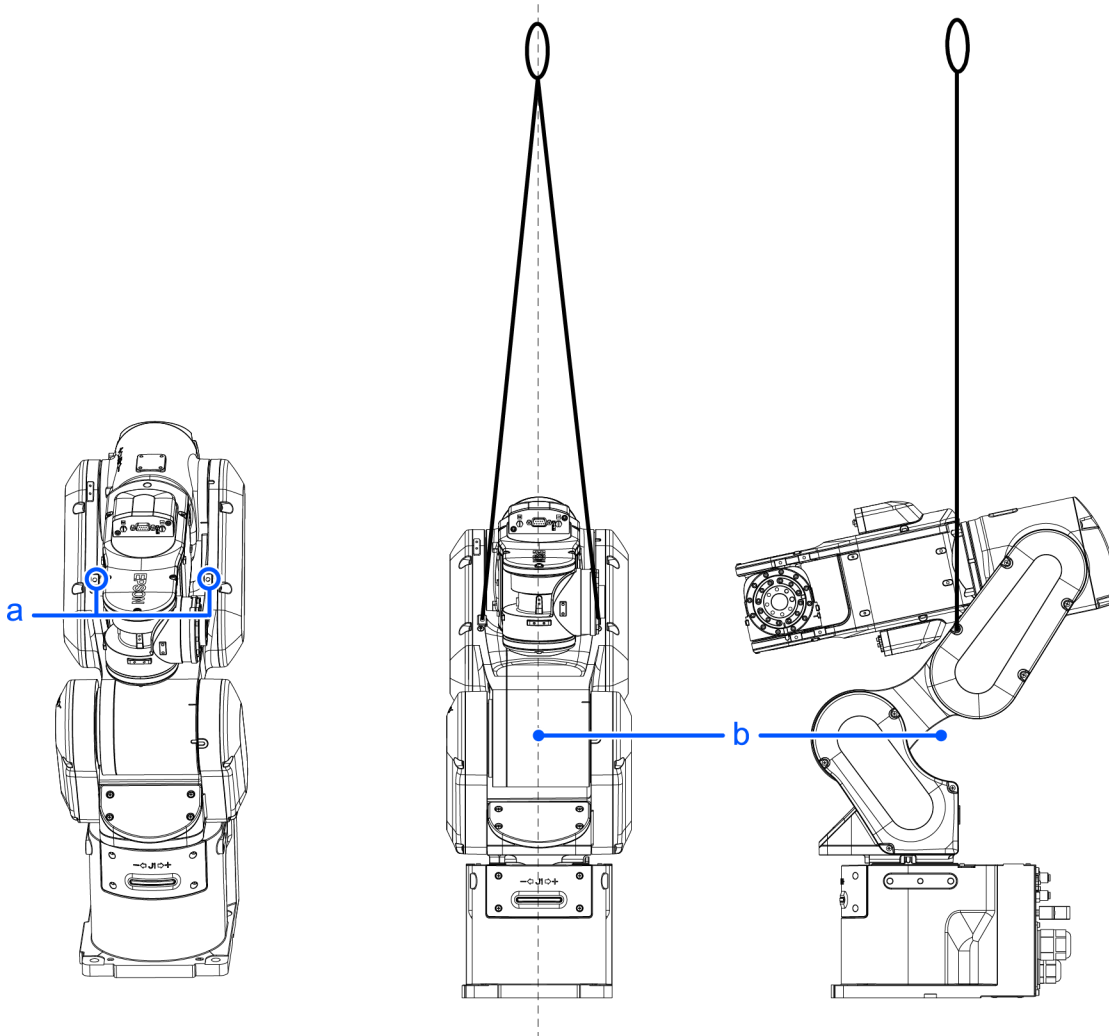

CX7-A901\*\*\*

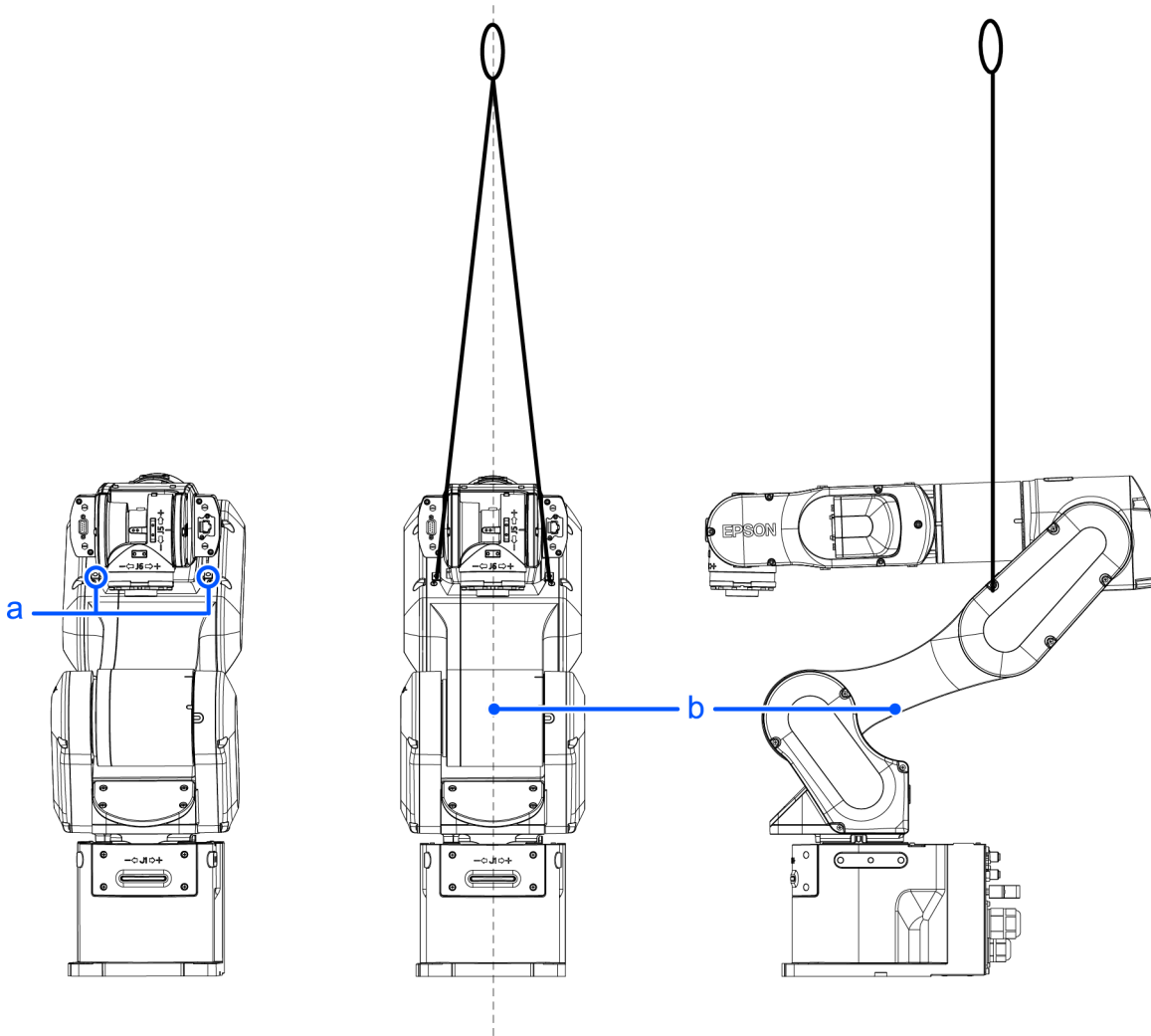

Symbol	Description
a	Threaded holes for eyebolts: 2×M6 depth 13
b	Center of gravity

\* Use the wire of 1000 mm or longer to avoid contact with Manipulator.  
Take extra care if you use the shorter wire to lift the Manipulator, because the wire is likely to touch Arm #4 or the side cover and break the Manipulator.

**⚠ CAUTION**

- Remove the eyebolts from the Manipulator after transportation/relocation is completed.  
If the Manipulator is operated with the eyebolts left on it, the arm may collide with the eyebolts and it may cause equipment damage to and/or malfunction of the Manipulator.

## 3.4 Setting the Hand

### 3.4.1 Installing the Hand

The hand (end effector) must be prepared by the customer. For details on attaching the hand, refer to the following manual. "Hand Function Manual"

Flange dimensions of the wrist attached to the end of Arm #6 is as below.

**⚠ WARNING**

- Before attaching a hand or peripheral equipment, be sure to always turn off the Controller and related equipment and unplug the power cables. Performing any work procedure with the power turned on is extremely dangerous and may result in electric shock and/or malfunction of the robot system.

**⚠ CAUTION**

- When the hand is equipped with a workpiece gripping mechanism, ensure that the wiring and pneumatic tubes do not cause the hand to release the workpiece when the power is turned off. When the wiring and pneumatic tubes are not designed for the hand to maintain its grip on the workpiece when the power is turned off, pressing the emergency stop switch releases the workpiece, which may damage the robot system and the workpiece.

By default, all I/Os are designed to automatically turn off (0) when the power is shut off, when an emergency stop is triggered, or by the robot system's safety function.

However, I/Os set with the Hand function does not turn off (0) when executing the Reset statement, or when performing an emergency stop.

For the risk of the residual air pressure, conduct a risk assessment on the equipment and take the necessary protective measures.

#### Wrist flange

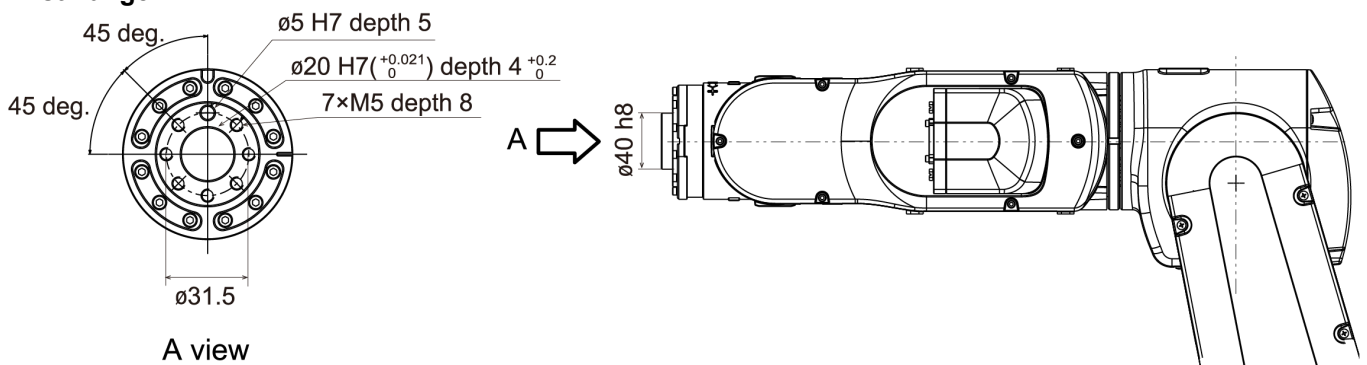

#### Arm #6

Attach the hand to the end of the Arm #6 using the M5 bolts.

#### Layout

When attaching and operating a hand, the hand may come into contact with the Manipulator body due to the outer diameter of the hand, the size of the workpiece, or the position of the arm. Carefully consider the interference area of the hand when designing the system layout.

### 3.4.2 Attaching Cameras and Valves

Decks are equipped to Arms #3 and #5 to enable the easy installation of air valve. If the payload exceeds the maximum payload, refer to the following section.

"**WEIGHT Setting** - Restrictions on payload exceeding the maximum payload"

To mount the camera, the camera plate unit is necessary. We provide the optional Camera Plate Unit. For details, refer to the following section.

**Options**

(Units: mm)

**CX7-A701\*\*\***

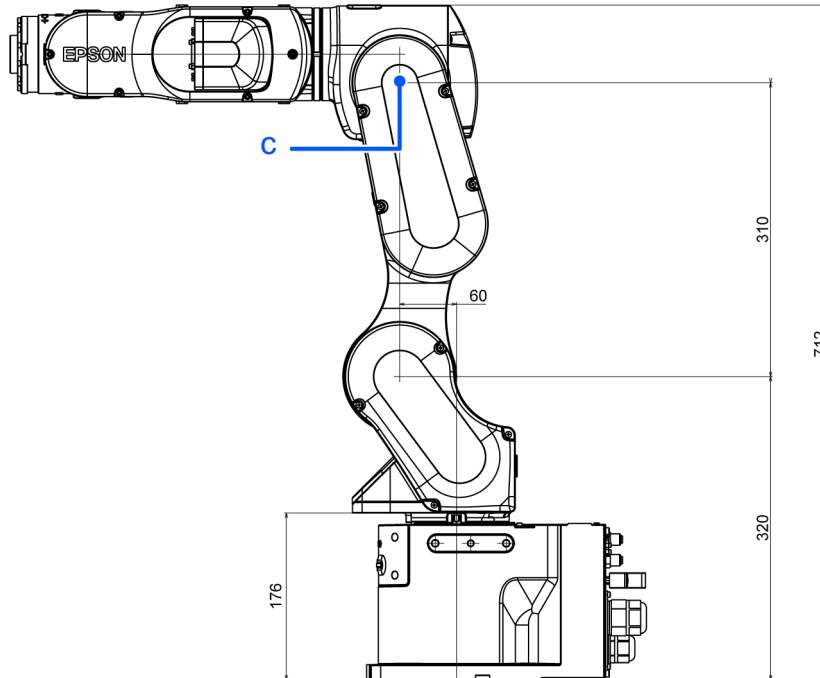
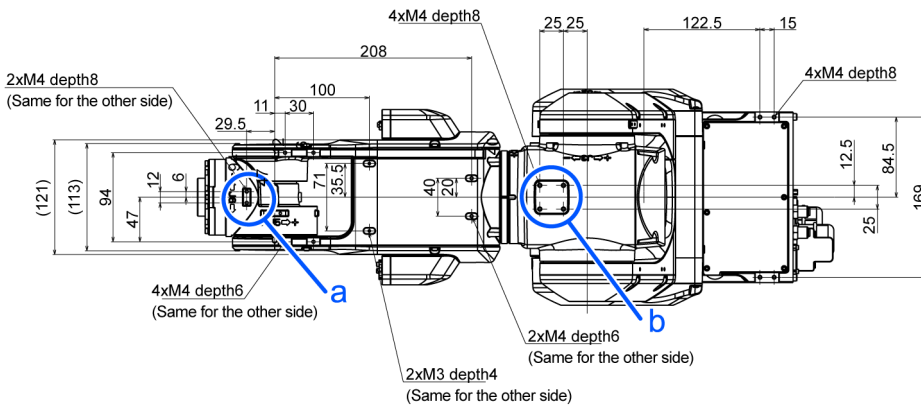

Symbol	Description
a	Arm #5 Deck
b	Arm #3 Deck
c	Rotation center of the upper arm

**CX7-A901\*\*\***

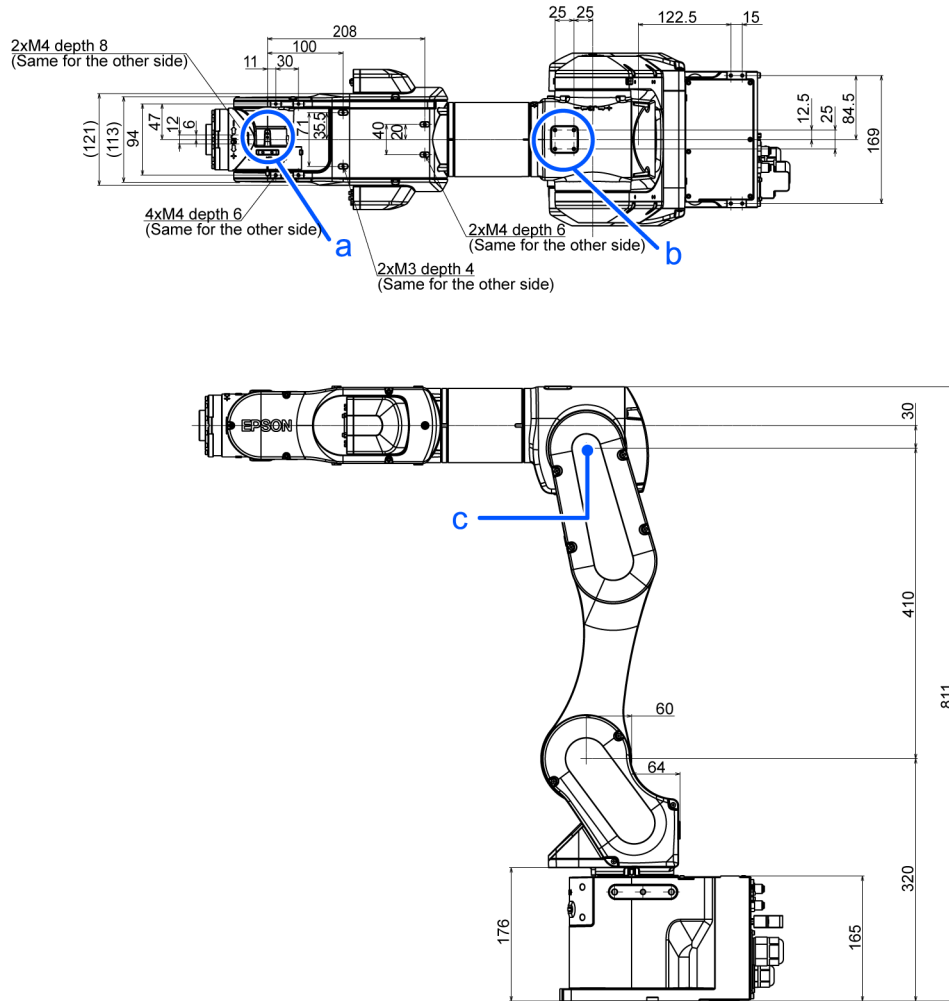

Symbol	Description
a	Arm #5 Deck
b	Arm #3 Deck
c	Rotation center of the upper arm

**3.4.3 WEIGHT and INERTIA Settings**

The WEIGHT and INERTIA commands are for setting the load parameters of the Manipulator. These settings optimize the Manipulator motion.

- WEIGHT Setting
 

The WEIGHT command is for setting the load weight. The more the load weight increases, the more the speed and acceleration/deceleration are reduced.
- INERTIA Setting
 

The INERTIA command is for setting the inertia moment and the eccentricity of the load. The more the inertia moment increases, the more the acceleration and deceleration of the Arm #6 are reduced. The more the eccentricity increases, the more the acceleration and deceleration for the Manipulator movement are reduced.

To ensure that the Manipulator is functioning properly, keep the load (the sum of the weights of the hand and workpiece) and the moment of inertia of the load within the rated values, and do not allow for eccentricity from the center of the Arm #6. If the load or the inertia moment exceeds the ratings or if the load becomes eccentric, follow the steps below to set parameters.

- **WEIGHT Setting**
- **INERTIA Setting**

Setting parameters makes the operation of the Manipulator optimal, reduces vibration to shorten the operating time, and improves the capacity for larger loads. This also works to curb any persistent vibration that may occur when the hand and workpiece have a large moment of inertia.

You can also perform settings using the "Weight, Inertia, and Eccentricity/Offset Measurement Utility."

For details, refer to the following manual.

"Epson RC+ User's Guide - Weight, Inertia, and Eccentricity/Offset Measurement Utility"

The allowable load for CX7 series Manipulators is up to 7 kg.

Due to the limitations of the moment and moment of inertia shown in the table below, the load (hand + workpiece) should also meet these conditions.

#### Allowable Load

Joint	Allowable moment	Allowable moment of inertia ( $GD^2/4$ )
Joint #4	16.9 N·m	0.49 $kg \cdot m^2$
Joint #5	16.9 N·m	0.49 $kg \cdot m^2$
Joint #6	9.4 N·m	0.15 $kg \cdot m^2$

#### Moment

The moment indicates amount of torque applied on the joint in order to support the gravity on the load hand + workpiece). The moment increases as weight of the load and amount of eccentricity increase. As this also increases the load applied on the joint, make sure to keep the moment within the allowable value.

#### Moment of inertia

The moment of inertia indicates how difficult the load (hand + workpiece) to rotate when the Manipulator joint starts to rotate (amount of inertia). The moment of inertia increases as weight of the load and amount of eccentricity increase. As this also increases the load applied on the joint, make sure to keep the moment within the allowable value.

The moment  $M$  (Nm) and moment of inertia  $I$  ( $kgm^2$ ) when the volume of the load (hand + workpiece) is small can be obtained by the following formula.

$$M \text{ (Nm)} = m \text{ (kg)} \times L \text{ (m)} \times g \text{ (m/s}^2\text{)}$$

$$I \text{ (kgm}^2\text{)} = m \text{ (kg)} \times L^2 \text{ (m)}$$

- $m$ : Weight of load (kg)
- $L$ : Eccentricity of load (m)
- $g$ : Gravitational acceleration ( $m/s^2$ )

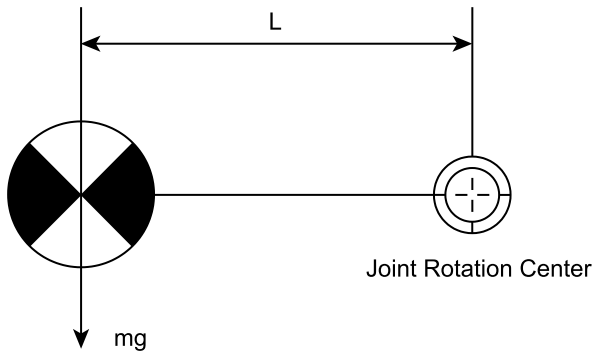

The figure below shows distribution of the center of gravity when the volume of the load (hand + workpiece) is small. Design the hand so that the center of gravity is within the allowable moment. If the volume of the load is large, calculate the moment and inertia moment by referring to the following section.

**"INERTIA Setting - Calculating the Moment of Inertia"**

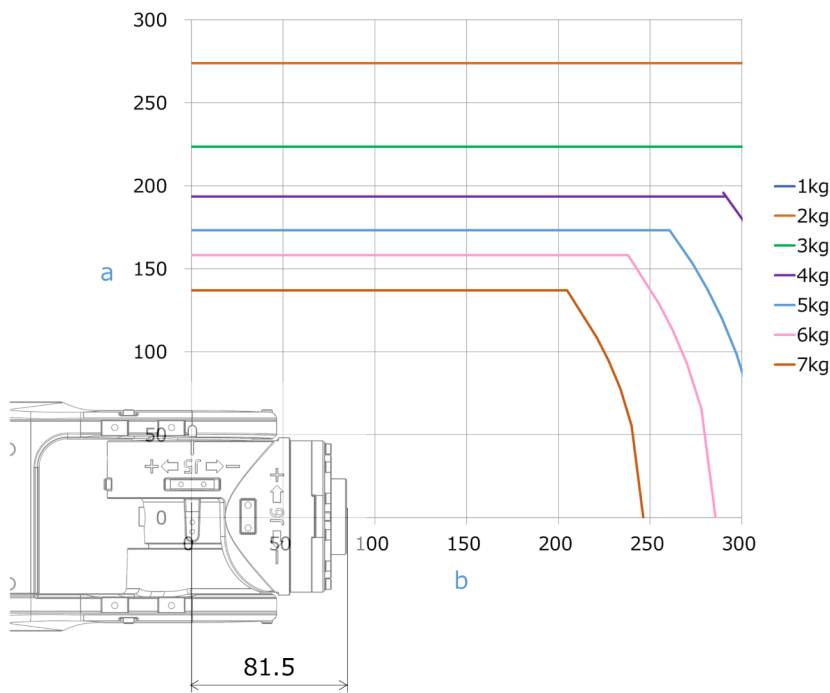

Symbol	Description
a	Distance from the center of Arm #* rotation [mm]
b	Center of gravity of load from the Arm #* rotation center [mm]

**Max. Eccentricity of Load (Distance between the joint rotation center and the load's center of gravity)**

Joint	1 kg	2 kg	3 kg	4 kg	5 kg	6 kg	7 kg
#4	300 mm	300 mm	300 mm	300 mm	300 mm	286 mm	246 mm
#5	300 mm	300 mm	300 mm	300 mm	300 mm	286 mm	246 mm
#6	300 mm	274 mm	224 mm	194 mm	173 mm	158 mm	137 mm

When calculating the critical dimension of the load using the allowable moment and inertia moment, the calculated value represents a distance from the Arm #6 rotation center, not the distance from the flange. To calculate the distance from the flange to the load's center of gravity, subtract the distance from the center of the Arm #5 rotation center to the flange (=81.5 mm) as shown in the example below.

Example: Calculation of the critical dimension of the load (A) when the load is 7 kg.

Center of gravity by the allowable moment control  $16.9 \text{ N}\cdot\text{m}/(7 \text{ kg} \times 9.8 \text{ m/s}^2) = 0.246 \text{ m} = 246 \text{ mm}$

Center of gravity by the allowable inertia moment control:  $(0.49 \text{ kgm}^2/7 \text{ kg})^{1/2} = 0.264 \text{ m} = 264 \text{ mm}$

Due to the allowable moment control, center of gravity for the load limit is 246 mm from the Arm #5 rotation center.

Distance from the flange to the center of gravity for the load limit  $A = 246 \text{ mm} - 81.5 \text{ mm} = 164.5 \text{ mm}$

**Critical Dimension of Load**

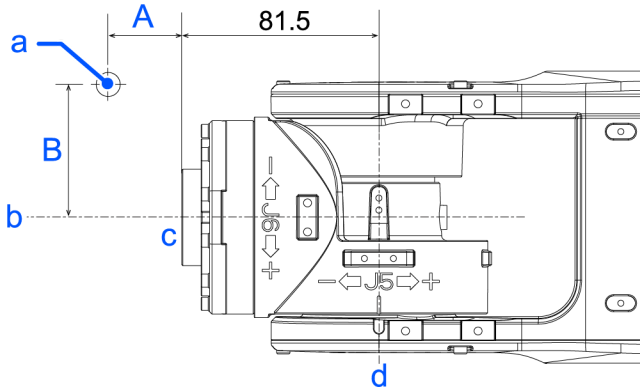

(Units: mm)

Symbol	Description
a	Load center of gravity position
b	Arm #6 rotation center
c	Flange
d	Arm #5 rotation center

**3.4.3.1 WEIGHT Setting**

**⚠ CAUTION**

- Set the total weight of the hand and the workpiece smaller than the maximum payload. The CX7 series Manipulators can operate without limitations on the condition unless and until the load exceeds this maximum payload. Always set the Weight parameters of the WEIGHT command according to the load. Setting a value smaller than the actual weight may cause errors or impact that not only impair full functionality but also shorten the life of the mechanical components.

The acceptable weight capacity (hand + workpiece) for CX7 series Manipulators is as follows:

Rated	Maximum
3 kg	7 kg

Change the setting of the Weight parameter according to the load. After changing the Weight parameter setting, the maximum acceleration/deceleration and speed of the robot system is set automatically.

**Setting method of Weight parameters**



Select [Tools]-[Robot Manager]-[Weight] panel and set the value in [Weight:]. You may also execute the Weight command from [Command Window].

**Load on the Manipulator**

Mounting location of the load

**CX7-A701\*\*\* (CX7)**

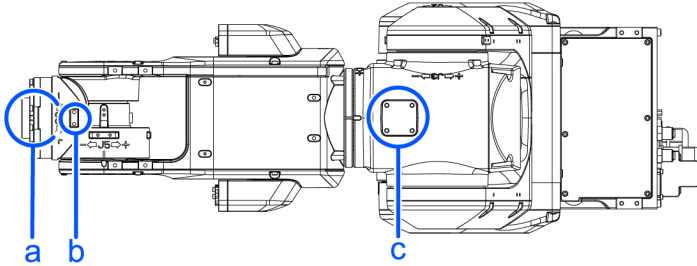

Symbol	Description
a	Load on the fore end of Arm #6
b	Arm #5 deck
c	Arm #3 deck

**CX7-A901\*\*\* (CX7L)**

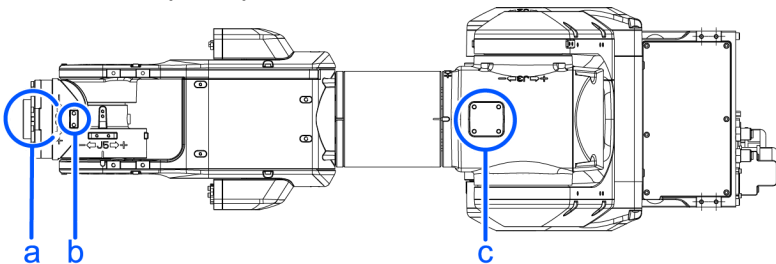

Symbol	Description
a	Load on the fore end of Arm #6
b	Arm #5 deck
c	Arm #3 deck

Deck detailed (Units: mm)

Arm #5 deck	Arm #3 deck

When you attach the equipment to the decks on the upper arm, convert its weight into equivalent weight assuming that the equipment is attached to the end of the Arm #6. Then, this equivalent weight added to the load will be a Weight parameter.

Calculate the Weight parameter by using the formula below and enter the value.

**Weight Parameter Formula**

Weight Parameter= $M_w + W_a + W_b$

- $M_w$ : Payload on the fore end of Arm #6 (kg)
- $W_a$ : Equivalent weight of the Arm #3 deck (kg)
- $W_b$ : Equivalent weight of the Arm #5 deck (kg)
- $W_a = M_a (L_a)^2 / (L)^2$
- $W_b = M_b (L_b)^2 / (L)^2$
- $M_a$ : Weight of the air valve on the Arm #3 deck (kg)
- $M_b$ : Weight of the camera on the Arm #5 deck (kg)
- L: Length of the upper arm (CX7-A701: 411.5 mm, CX7-A901: 511.5 mm)
- $L_a$ : Distance between the Joint #3 and the center of gravity of the air valve on the Arm #3 deck (mm)
- $L_b$ : Distance between the Joint #3 and the center of gravity of the camera on the Arm #5 deck (mm)

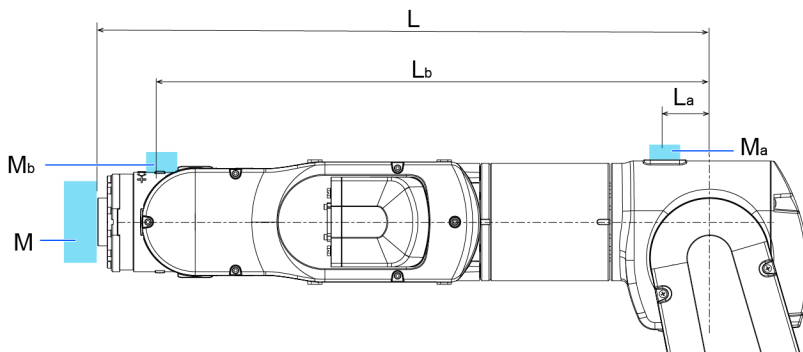

Example:

When the following loads apply to CX7-A901\*\*\* which fore end of the Arm #6 is 511.5 mm (L) away from the Joint #3 and payload ( $M_w$ ) is 5 kg:

- Load on the Arm #3 deck is 1.5 kg ( $M_a$ ). The deck is 0 mm ( $L_a$ ) away from the Joint #3.
- Load on the Arm #5 deck is 1.0 kg ( $M_b$ ). The deck is 460 mm ( $L_b$ ) away from the Joint #3.

$W_a = 1.5 \times 0^2 / 511.5^2 = 0$

$W_b = 1.0 \times 460^2 / 511.5^2 = 0.81 \rightarrow 0.9$  (round up)

$M_w + W_a + W_b = 5 + 0 + 0.9 = 5.9$

Enter "5.9" for the Weight parameter.

**Automatic speed setting by Weight parameter**

The percentages on the graph are ratios based on 100% as the [Maximum operating speed] of CX7 specifications.

**CX7-A701\*\*\***

Standard mode

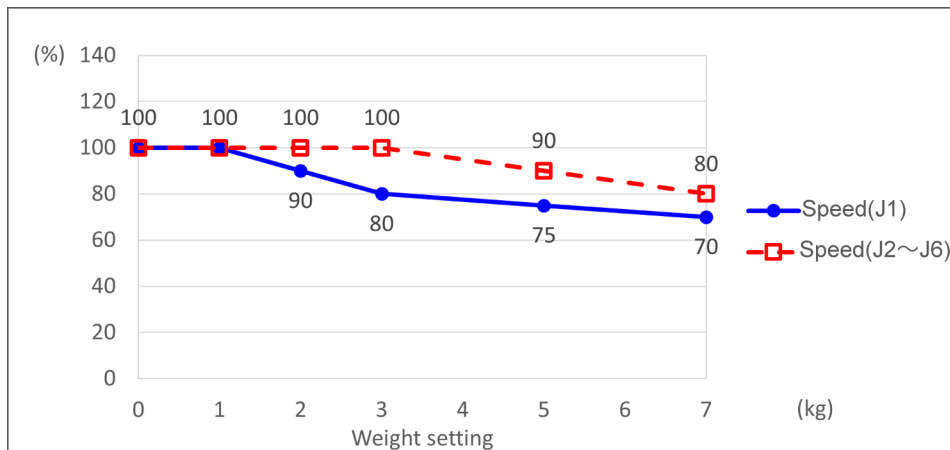

Boost mode

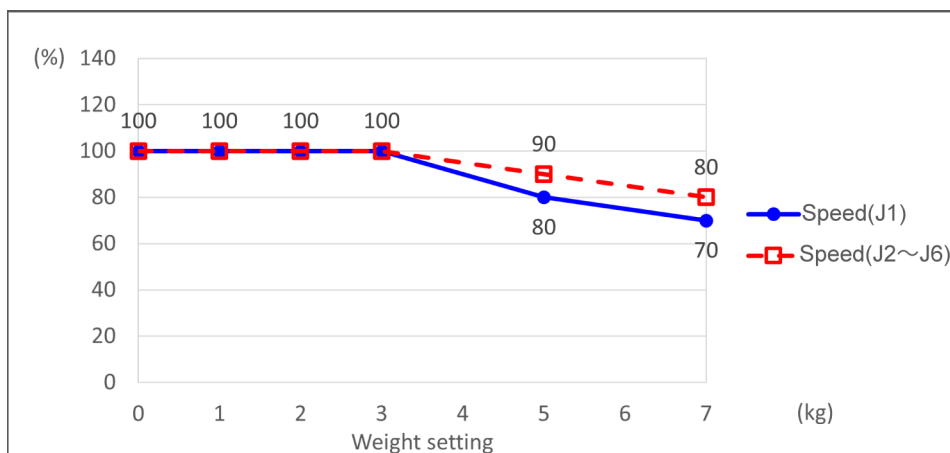

**CX7-A901\*\*\***

Standard mode

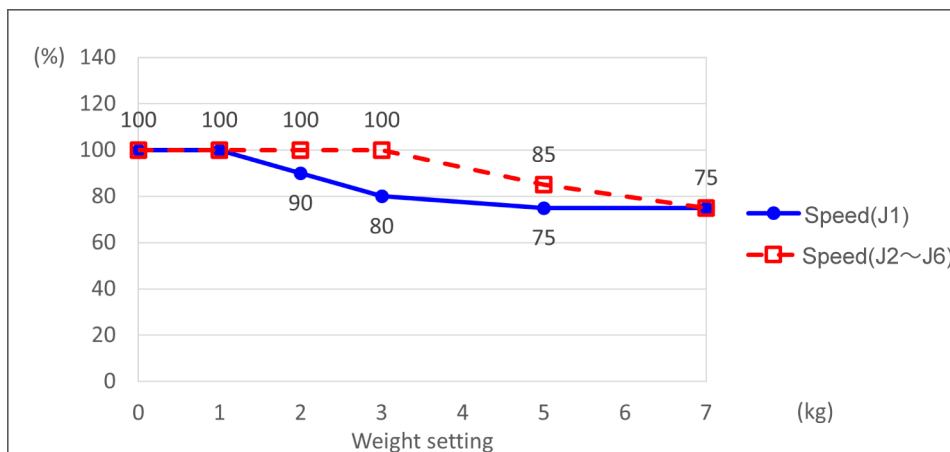

Boost mode

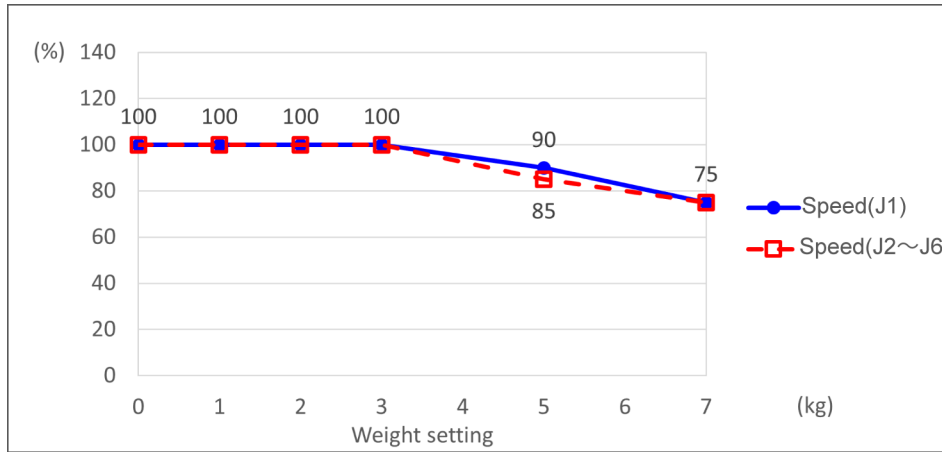

 KEY POINTS

Maximum AccelS setting value varies depending on Weight setting value. For details, refer to the following section.

[CX7 Specifications](#)

**Automatic speed setting by Weight parameter**

The percentages on the graph are ratios based on 100% as the acceleration/deceleration at the rated (3 kg) setting for each of the standard and boost mode.

For details on the automatic acceleration/deceleration setting of J6, refer to the following:

[INERTIA Setting](#)

**CX7-A701\*\*\***

Standard mode

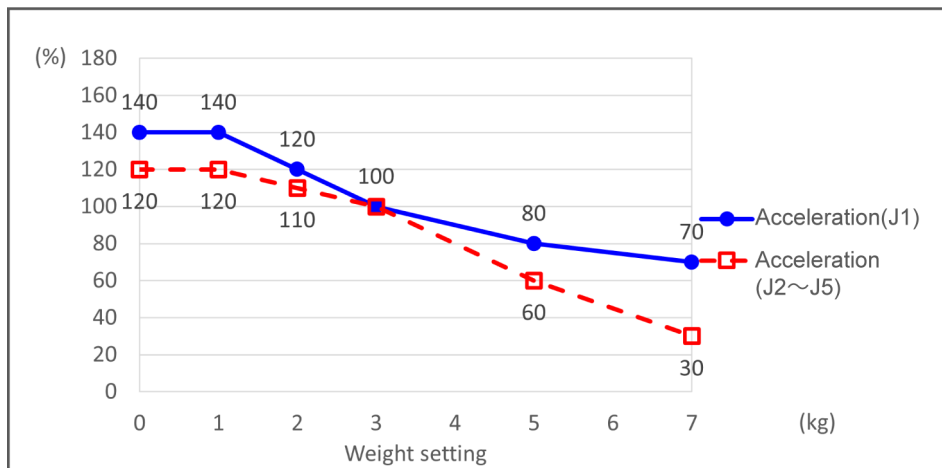

Boost mode \*1

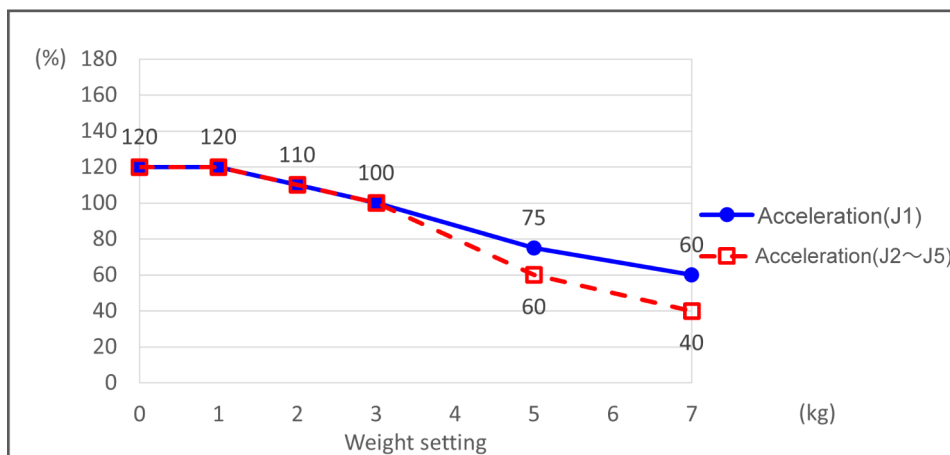

**CX7-A901\*\*\***

Standard mode

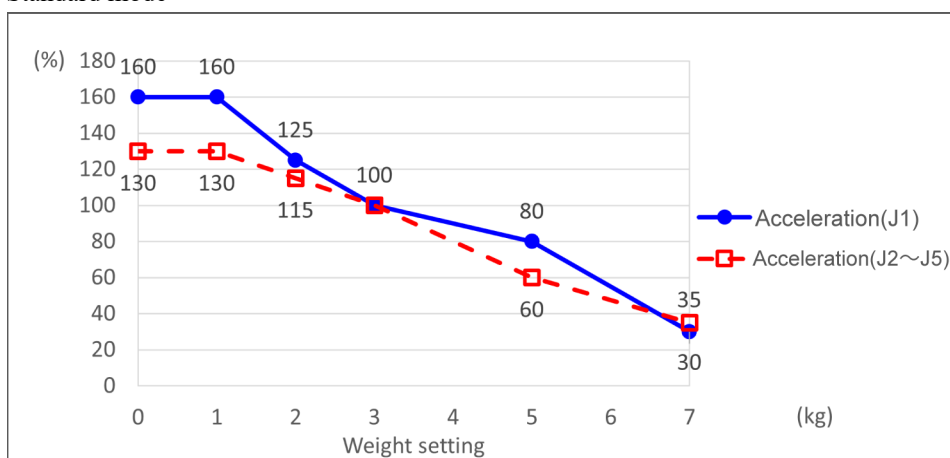

Boost mode \*1

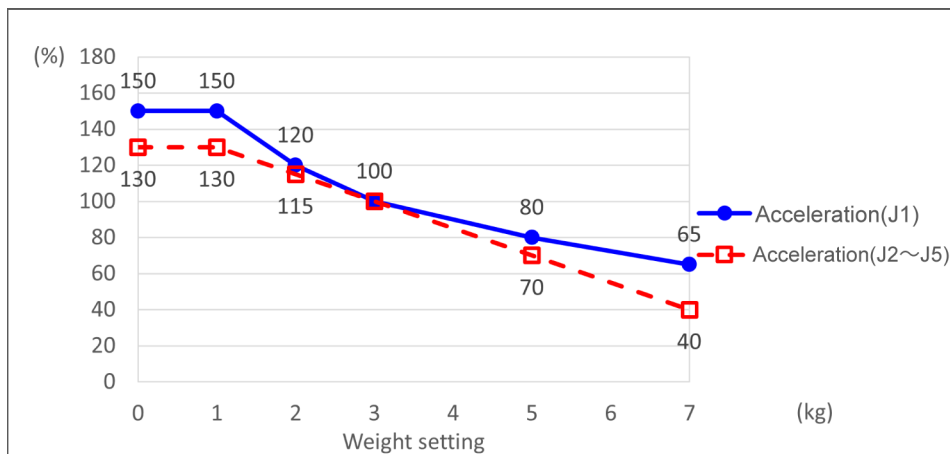

\*The rated acceleration and deceleration speed (100%) of the boost mode is faster than the standard mode.

### 3.4.3.2 INERTIA Setting

#### Moment of Inertia and INERTIA Setting

The moment of inertia is a quantity that expresses how hard it is for an object to turn, and it is expressed in terms of values for

the moment of inertia, inertia, or  $GD^2$ . When a hand or other object is attached to the Arm #6 for operation, the moment of inertia of the load must be taken into consideration.

**⚠ CAUTION**

- The moment of inertia of the load (hand + workpiece) must be  $0.15\text{kg}\cdot\text{m}^2$  or less.

The CX7 Manipulators are not designed to work with a moment of inertia exceeding  $0.15\text{kg}\cdot\text{m}^2$ . Always set the value corresponding to the moment of inertia. Setting a parameter value that is smaller than the actual moment of inertia may cause errors or impact, may prevent the Manipulator from working at full functionality, and may shorten the lifespan of mechanical parts.

The allowable moment of inertia of a load for CX7 Manipulators is  $0.03\text{kg}\cdot\text{m}^2$  at the default rating and  $0.15\text{kg}\cdot\text{m}^2$  at the maximum. Change the setting of the moment of inertia according to the inertia moment of the load using the INERTIA command. After the setting is changed, the maximum acceleration/deceleration of Arm #6 that corresponds to the "Inertia" value is corrected automatically.

**Moment of Inertia of Load Attached to Arm #6**

The moment of inertia of the load (hand + workpiece) attached to the Arm #6 can be set by the "Inertia" parameter in the Inertia statement.

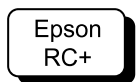

Go to [Tools] - [Robot Manager] - [Inertia] panel, and enter the value in [Inertia]. This can also be set using the Inertia statement in [Command Window].

**Eccentricity and INERTIA Setting**

**⚠ CAUTION**

- The eccentricity of the load (hand + workpiece) must be 300 mm or less. The CX7 series Manipulators are not designed to work with eccentricities exceeding 300 mm. Always set the value based on the eccentricity. Setting the eccentricity parameter to a value smaller than the actual eccentricity may cause errors or impact that not only impair full functionality but also shorten the life of the mechanical components.

The allowable eccentricity of load for CX7 Manipulators is 50 mm at the default rating and 300 mm at the maximum. When the load eccentricity exceeds the rating, change the setting for the eccentricity parameter in Inertia statement. After the setting is changed, the maximum acceleration/deceleration of the Manipulator that corresponds to the "Eccentricity" is corrected automatically.

Eccentricity

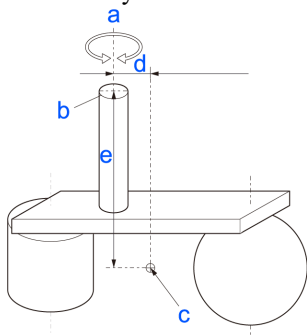

Symbol	Description
a	Rotation axis
b	Flange
c	Load center of gravity position
d, e	Eccentricity (300 mm or less) To set the parameter, enter the larger value of "d" or "e".

**Eccentricity of Load Attached to Arm #6**

The eccentricity of the load (hand + workpiece) attached to the Arm #6 can be set by the "Eccentricity" parameter in the Inertia statement.

Enter the larger value of either "d" or "e" in the figure above to [Eccentricity].

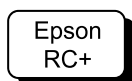

Go to [Tools] - [Robot Manager] - [Inertia] panel, and enter the value in [Eccentricity]. This can also be set using the Inertia statement in [Command Window].

**Automatic Acceleration/Deceleration Correction at INERTIA (Moment of inertia) Setting**

The percentages on the graph are ratios based on 100% as the acceleration/deceleration at the rated (0.03 kg·m<sup>2</sup>) setting. Correction for both the standard and boost mode are the same.

**CX7-A701\*\*\*, CX7-A901\*\*\***

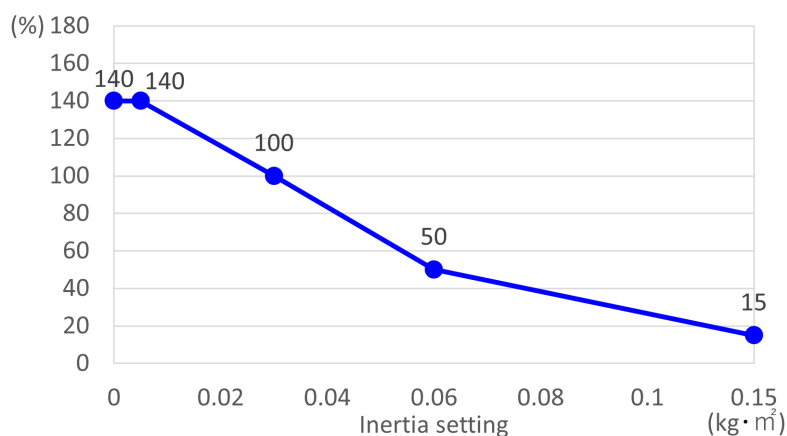

**Automatic Acceleration/Deceleration Correction at INERTIA (Eccentricity) Setting**

The percentages on the graph are ratios based on 100% as the acceleration/deceleration at the rated (50 mm) setting. The eccentricity correction varies depending on the WEIGHT setting. Correction for both the standard and boost mode are the same.

**CX7-A701\*\*\***

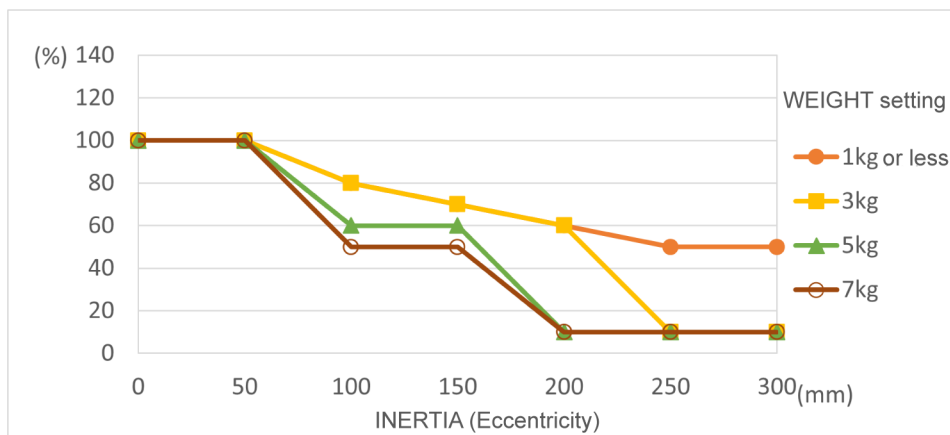

**CX7-A901\*\*\***

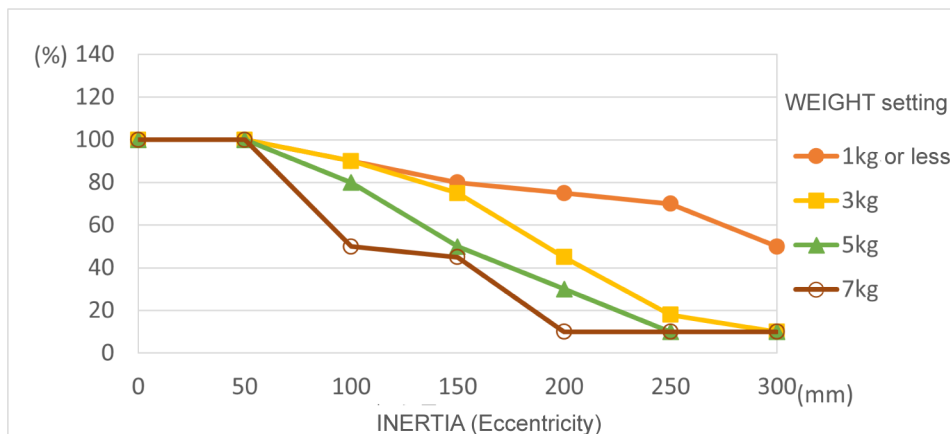

**Calculating the Moment of Inertia**

An example of calculating the moment of inertia of a load (hand holding a workpiece) is shown below.

The moment of inertia of the entire load is calculated by the sum of (A), (B), and (C).

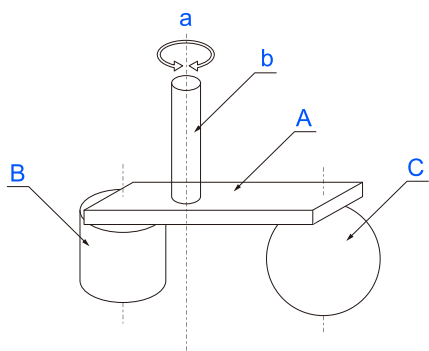

$$\text{Whole moment of inertia} = \text{Moment of inertia of end effector (A)} + \text{Moment of inertia of work piece (B)} + \text{Moment of inertia of work piece (C)}$$

Symbol	Description
a	Rotation axis
b	Shaft
A	Hand
B	Workpiece
C	Workpiece

The methods for calculating the moment of inertia for (A), (B), and (C) are shown below. Use the moment of inertia of these basic shapes as a reference to find the moment of inertia of the entire load.

**(A) Moment of inertia of a rectangular parallelepiped**

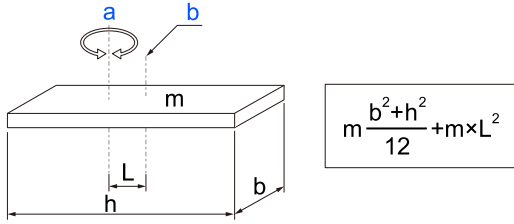

Symbol	Description
a	Rotation axis
b	Center of gravity of rectangular parallelepiped
m	Weight

**(B) Moment of inertia of a cylinder**

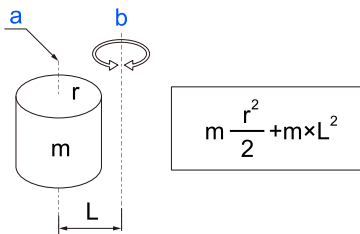

Symbol	Description
a	Center of gravity of cylinder
b	Rotation axis
m	Weight

**(C) Moment of inertia of a sphere**

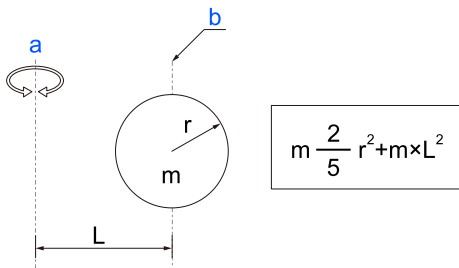

Symbol	Description
a	Rotation axis
b	Center of gravity of sphere
m	Weight

**3.4.4 Safety Information for Auto Acceleration**

The speed and acceleration/deceleration of the Manipulator motion are automatically optimized according to the values of WEIGHT and INERTIA and the Manipulator's postures.

**WEIGHT Setting**

The speed and acceleration/deceleration of the Manipulator are controlled according to the load weight set by the WEIGHT command. The more the load weight increases, the more the speed and acceleration/deceleration are reduced to prevent residual vibration.

**INERTIA Setting**

The acceleration/deceleration of Arm #6 are controlled according to the inertia moment set by the INERTIA command. The acceleration/deceleration of the whole Manipulator are controlled according to the eccentricity set by the INERTIA command. The more the inertia moment and eccentricity of the load increase, the more the acceleration/ deceleration are reduced.

**Auto Acceleration/Deceleration According to Manipulator's Posture**

The acceleration/deceleration are controlled according to the Manipulator's posture. When the Manipulator extends its arms or when the movement of the Manipulator produces vibration frequently, the acceleration/deceleration are reduced.

Set appropriate values for WEIGHT and INERTIA so that the Manipulator operation is optimized.

## 3.5 Work Envelope

### ⚠ CAUTION

When restricting the work envelope for safety reasons, be sure to make settings using both the pulse range and mechanical stop.

The work envelope is preset at the factory as explained in the following section. This is the maximum work envelope of the Manipulator.

#### Standard Work Envelope

The work envelope can be set by one of the following three methods.

1. Setting by pulse range (for each joint)
2. Setting by mechanical stops
3. Setting the Rectangular Range in the XY Coordinate System of the Manipulator

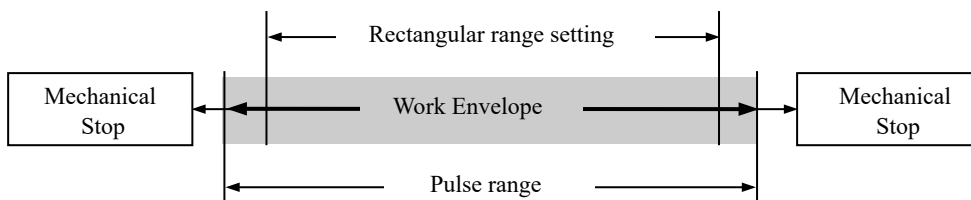

To limit the work envelope for layout efficiency or safety reasons, make the settings as explained in the following sections.

- [Work Envelope Setting by Pulse Range \(for Each Joint\)](#)
- [Setting the Work Envelope by Mechanical Stops](#)
- [Restriction of Manipulator Operation by Joint Angle Combination](#)
- [Coordinate System](#)

### 3.5.1 Work Envelope Setting by Pulse Range (for Each Joint)

Pulses are the basic unit of Manipulator motion. The motion range (work envelope) of the Manipulator is set by the pulse lower limit value and pulse upper limit value (pulse range) for each joint. Pulse values are read from the encoder output of the servomotor.

Be sure to set the pulse range within the mechanical stop range.

#### ✍ KEY POINTS

- Once the Manipulator receives a motion command, it checks whether the target position specified by the command is within the pulse range before operating. If the target position is outside of the pulse range that was set, an error occurs and the Manipulator does not move.

Epson  
RC+

Go to [Tools] - [Robot Manager] - [Range] panel, and make the setting. This can also be set using the Range statement in [Command Window].

### 3.5.1.1 Joint #1 Maximum Pulse Range

With the 0 pulse as a starting point, the counterclockwise pulse value is defined as positive (+), and the clockwise pulse value is defined as negative (-).

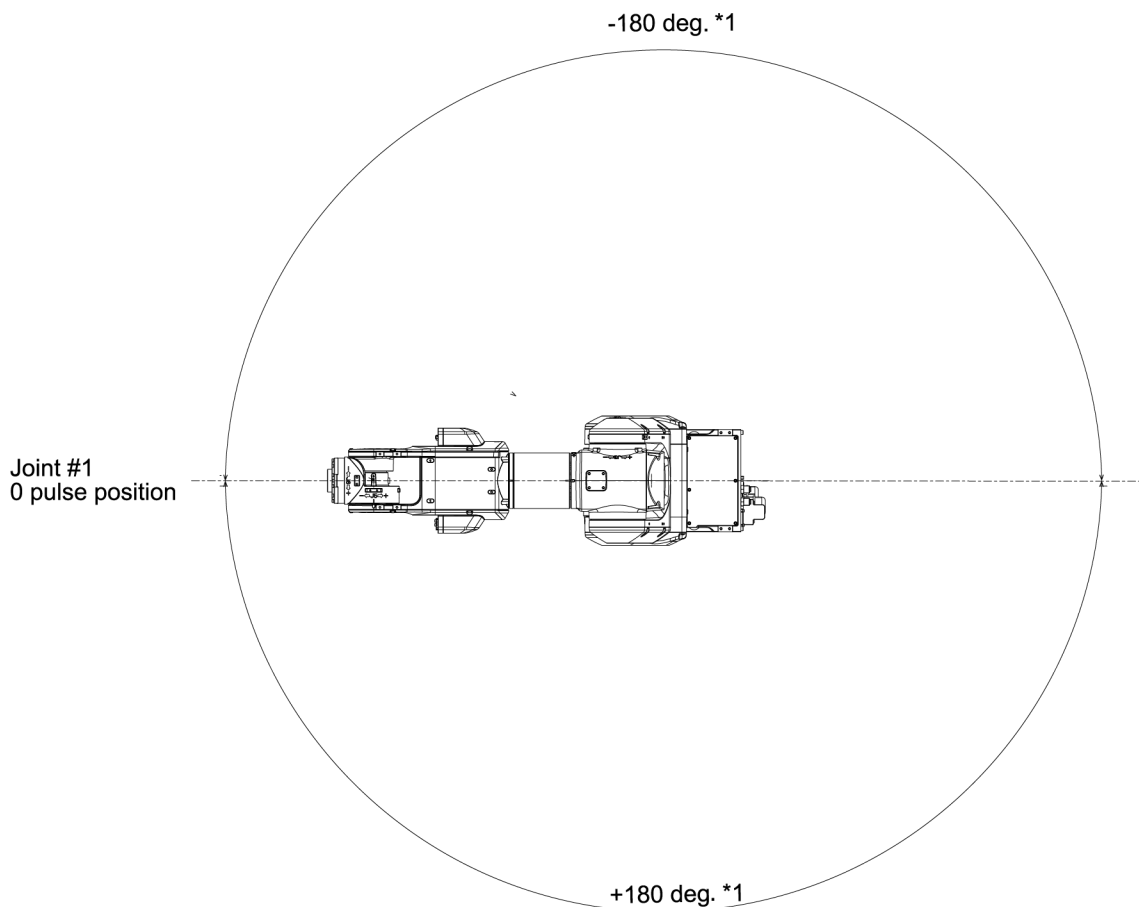

	CX7-A701\ ***	CX7-A901***
Angle (°)	±180	
Pulse	±5620677	±7008498

### 3.5.1.2 Joint #2 Maximum Pulse Range

With the 0 pulse as a starting point, the clockwise pulse value is defined as positive (+), and the counterclockwise pulse value is defined as negative (-).

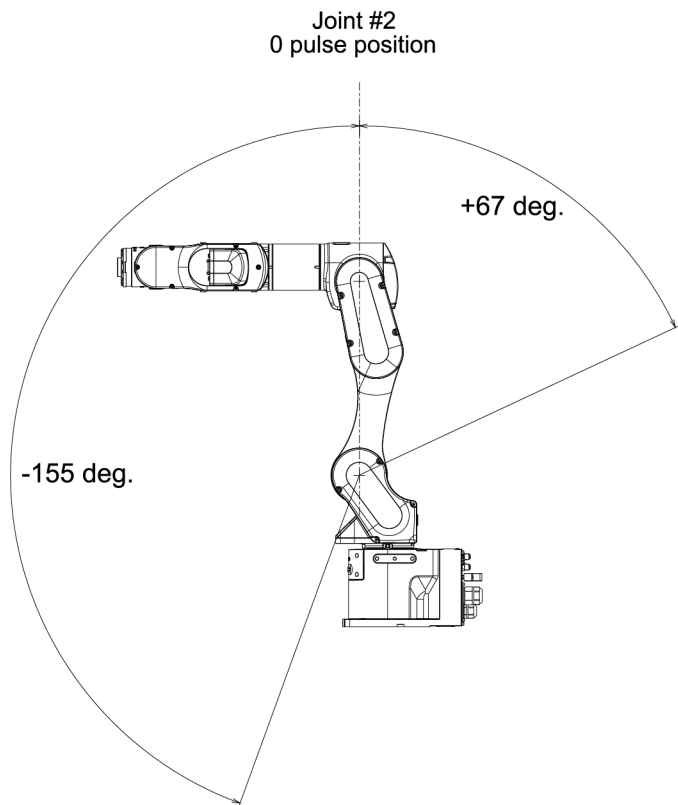

	CX7-A701\ ***	CX7-A901***
Angle (°)	-155 to +67	
Pulse	-5540771 to +2395044	-6908863 to +2986412

### 3.5.1.3 Joint #3 Maximum Pulse Range

With the 0 pulse as a starting point, the clockwise pulse value is defined as positive (+), and the counterclockwise pulse value is defined as negative (-).

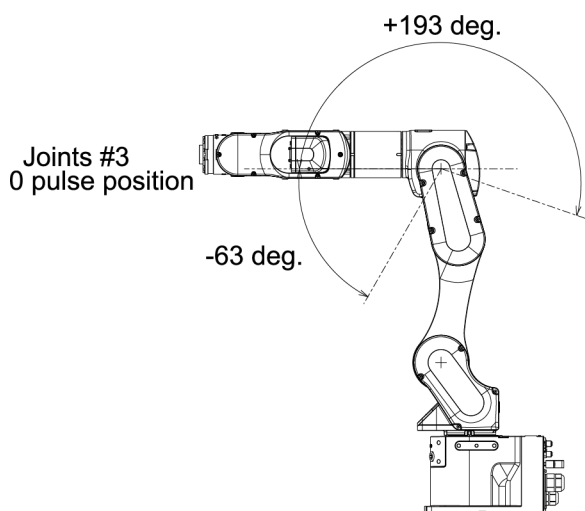

	CX7-A701\ ***	CX7-A901***
Angle (°)	-63 to +193	
Pulse	-1520139 to +4656929	-1895480 to +5806788

### 3.5.1.4 Joint #4 Maximum Pulse Range

From the angle of arm end, with the 0 pulse as a starting point, the clockwise pulse value is defined as positive (+), and the counterclockwise pulse value is defined as negative (-). The max. pulse range of the Arm #4 is common to CX7 series Manipulators.

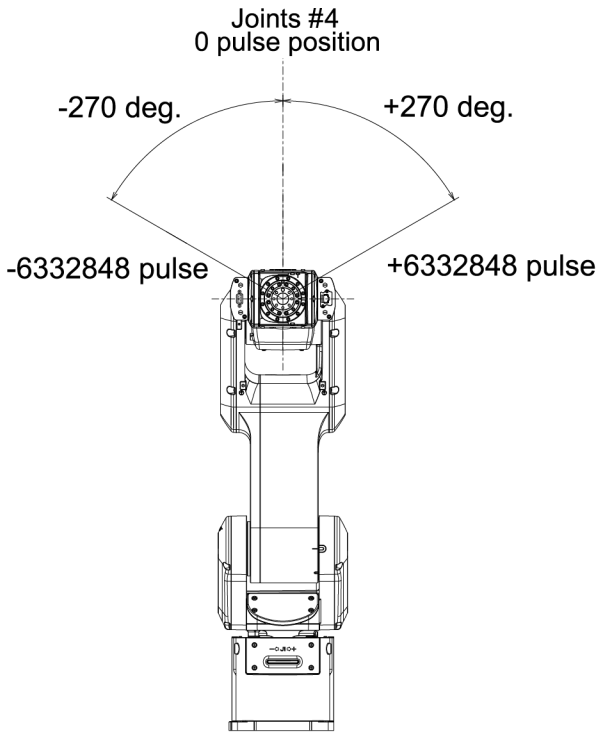

(deg.=°)

### 3.5.1.5 Joint #5 Maximum Pulse Range

With the 0 pulse as a starting point, the clockwise pulse value is defined as positive (+), and the counterclockwise pulse value is defined as negative (-). The max. pulse range of the Arm #5 is common to CX7 series Manipulators.

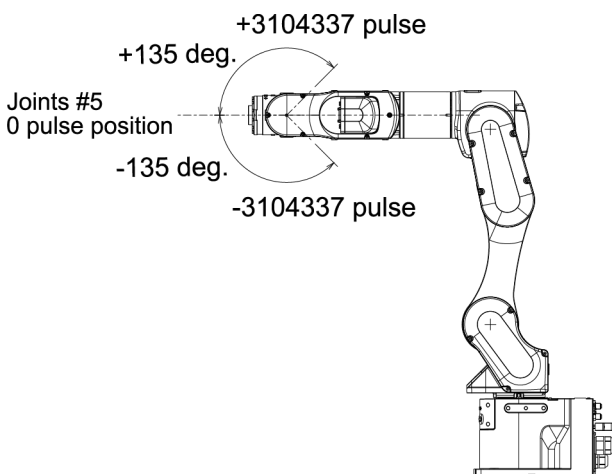

(deg.=°)

### 3.5.1.6 Joint #6 Maximum Pulse Range

From the angle of arm end, with the 0 pulse as a starting point, the clockwise pulse value is defined as positive (+), and the counterclockwise pulse value is defined as negative (-). The max. pulse range of the Arm #6 is common to CX7 series Manipulators.

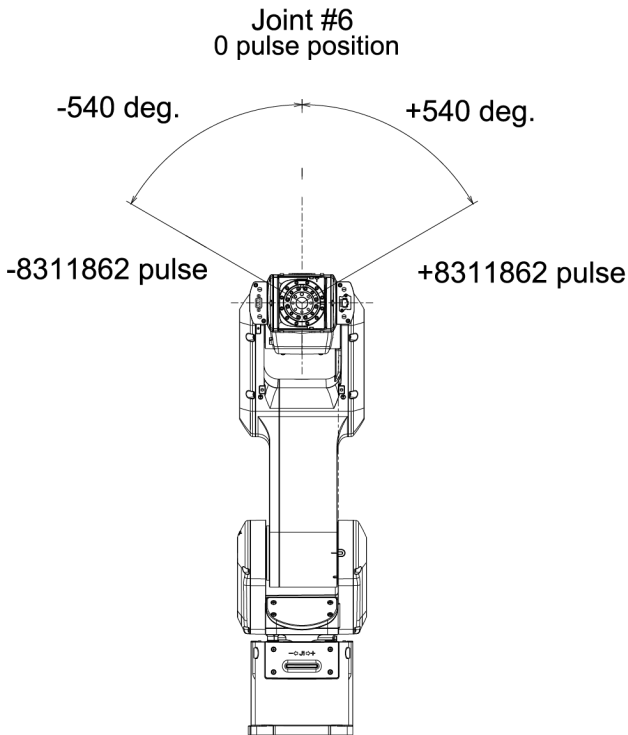

(deg.=°)

### 3.5.2 Setting the Work Envelope by Mechanical Stops

Using the variable mechanical stops physically limits the absolute area that the Manipulator can move.

Before starting any work, be sure to turn off the Manipulator.

Use bolts conforming to the specified length and surface processing (ex: nickel plating) with high corrosion resistance.

Specify the pulse range again after changing the position of the mechanical stop.

For details on the pulse range setting, refer to the following section.

#### [Work Envelope Setting by Pulse Range \(for Each Joint\)](#)

Be sure to set the pulse range inside the positions of the mechanical stop range.

#### 3.5.2.1 Setting the Joint #1 Work Envelope

Install variable mechanical stop (J1) in the threaded holes corresponding to the angles to be set.

Normally a mechanical stop is not equipped.

- Hexagon socket head cap bolt: M12 × 30 × 2 bolts
- Strength: Compliant with ISO 898-1 property class: 10.9 or 12.9
- Tightening torque: 42.0 ± 2.1 N·m (428 ± 21 kgf·cm)

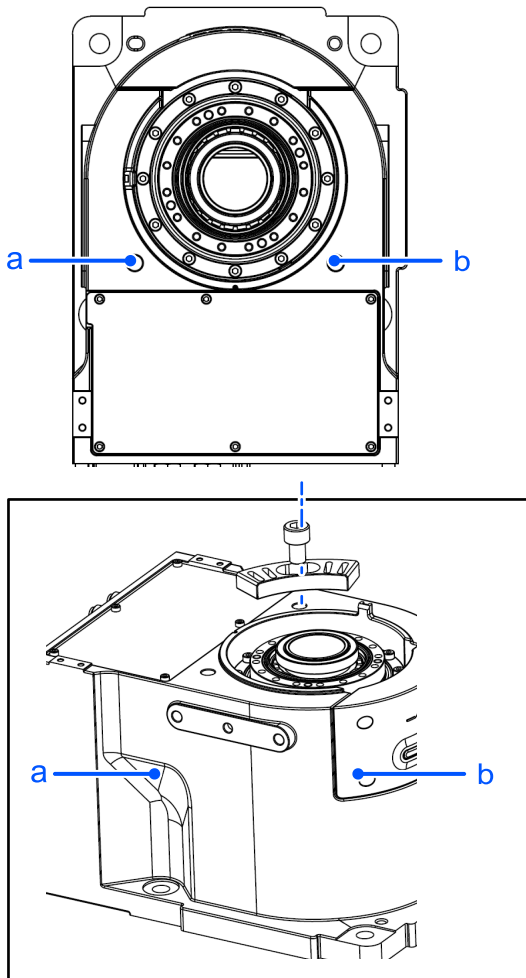

		a	b	c
Angle (°)		±110	±105	±240
Pulse	CX7-A701\ ***	±4902150	±4679271	±10695600
	CX7-A901\ ***	±7212700	±6884840	±15736800
Variable Mechanical Stop (J1)		Applied	Applied	Not applied (standard)

### 3.5.3 Restriction of Manipulator Operation by Joint Angle Combination

To prevent the arms of the Manipulator from interfering each other, the Manipulator operation is restricted in the specified motion range according to the angle combination of the Joint #1, #2, and #3.

The Manipulator operation is restricted and the Manipulator stops when the joint angles are within the colored areas in the following figure.

**The restriction to Manipulator operation is enabled:**

- During CP motion command execution
- When you attempt to execute the motion command for moving the Manipulator to a target point (or pose) in the specified motion range.

**The restriction to the Manipulator operation is disabled:**

- The Arms of the Manipulator momentarily go through the specified motion range during the PTP motion command execution even though the joint angles of the Arms are in the colored areas of the figures above.

**Combination of Joint #1 and #2 (CX7-A701\*\*\*)**

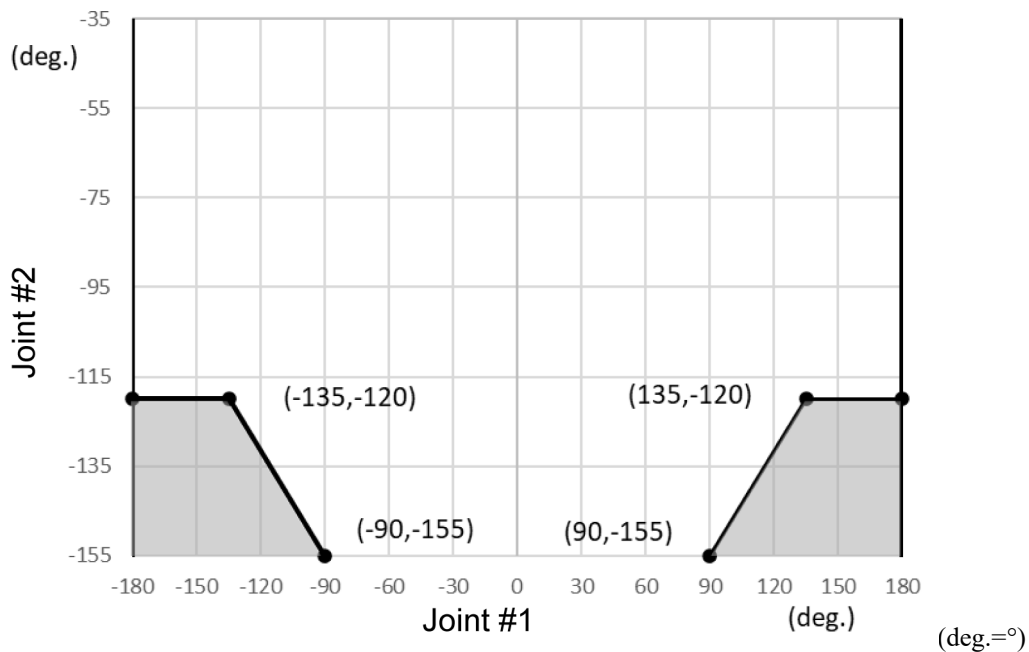

**Combination of Joint #2 and #3 (CX7-A701\*\*\*)**

- -135 deg.  $\leq$  J1  $\leq$  -135 deg.

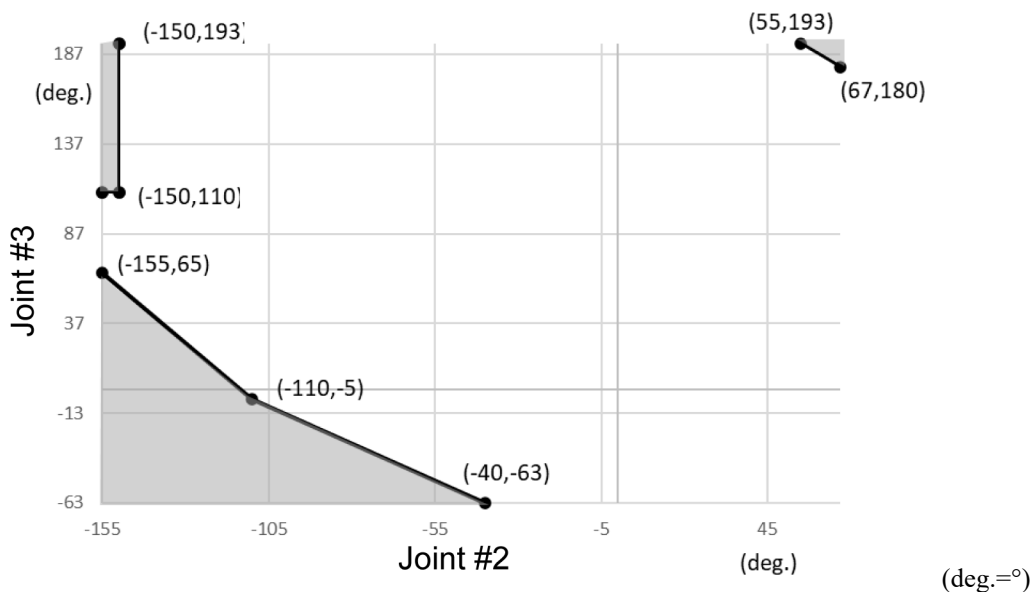

- $-180 \text{ deg.} \leq J1 < -135 \text{ deg.}$  or  $135 \text{ deg.} < J1 \leq 180 \text{ deg.}$

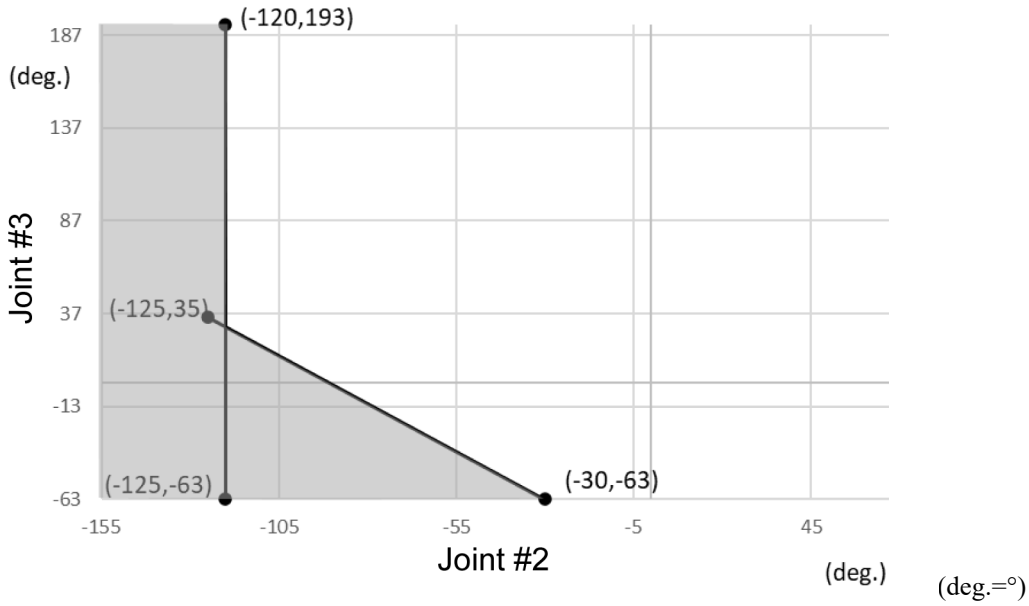

**Combination of Joint #1 and #2 (CX7-A901\*\*\*)**

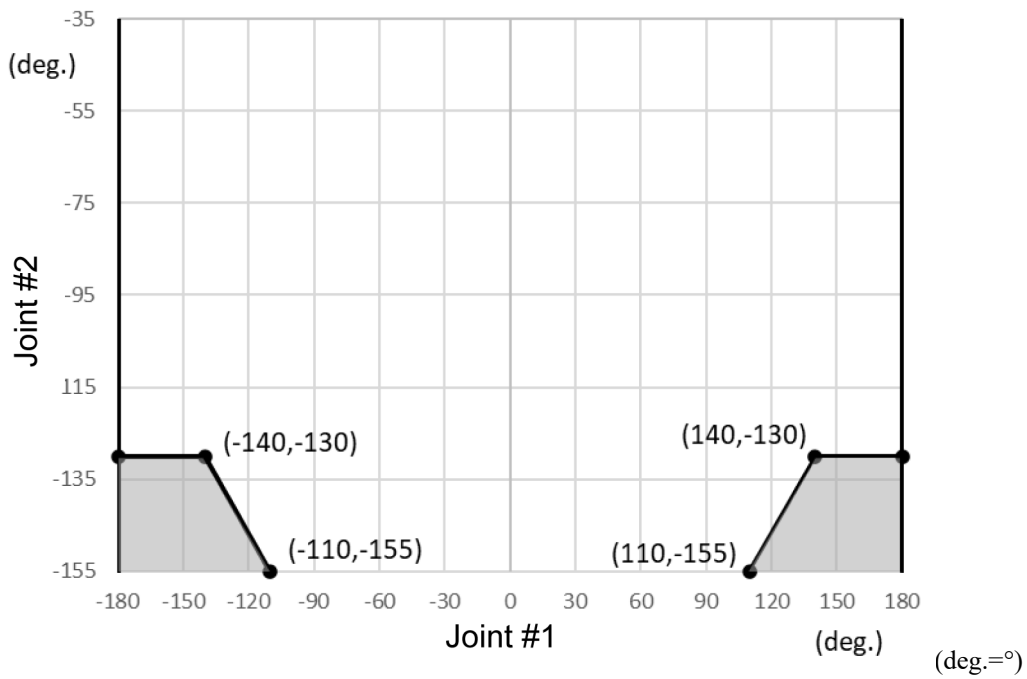

**Combination of Joint #2 and #3 (CX7-A901\*\*\*)**

- $-140 \text{ deg.} \leq J1 \leq -140 \text{ deg.}$

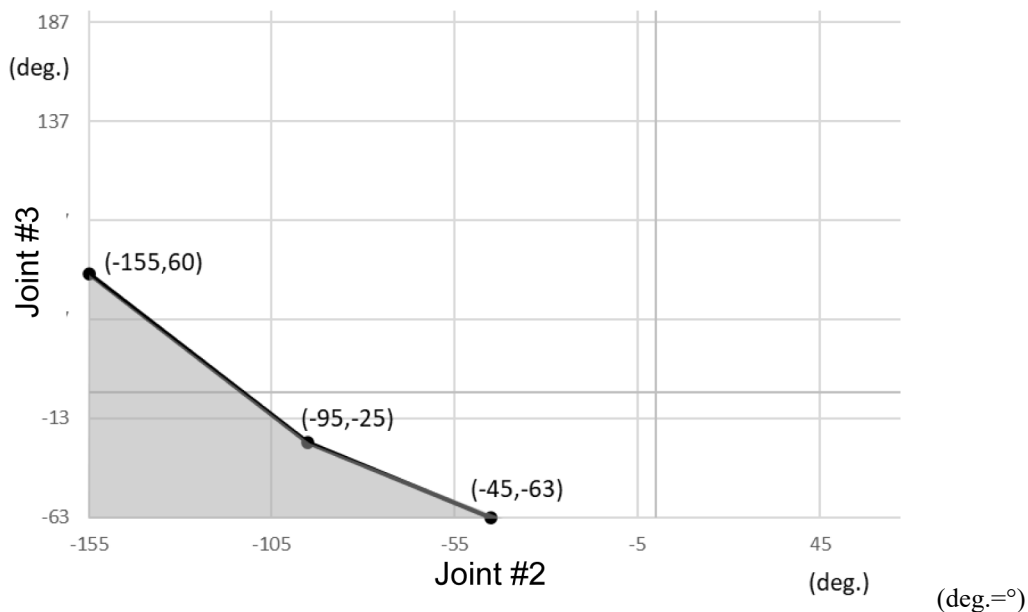

- $-180 \text{ deg.} \leq J1 < -140 \text{ deg.}$  or  $140 \text{ deg.} < J1 \leq 180 \text{ deg.}$

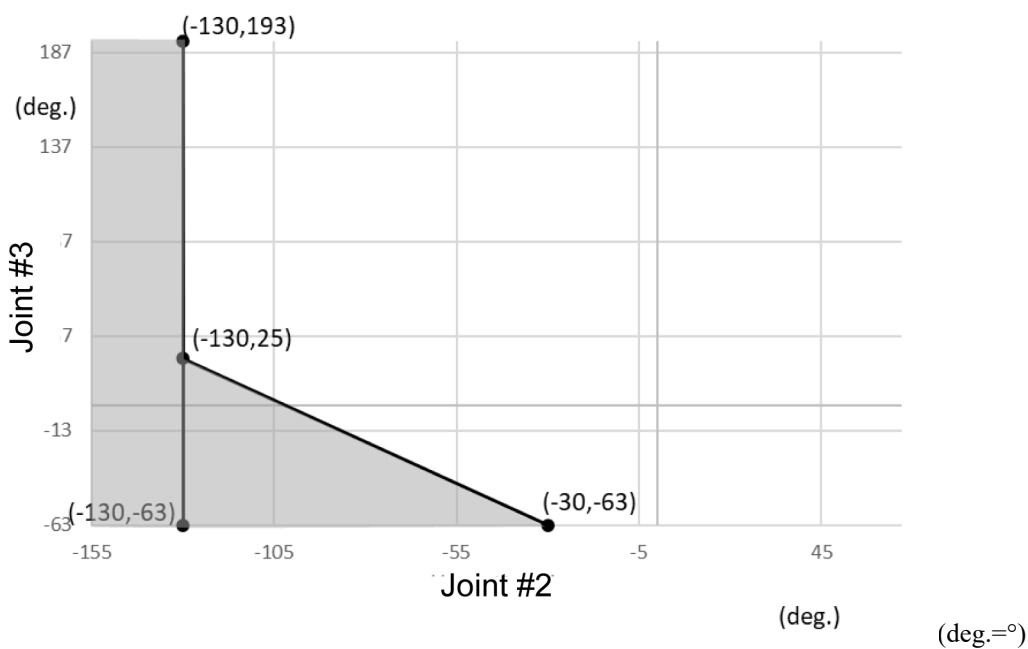

### 3.5.4 Coordinate System

The origin point is where the Manipulator's installation face intersects with the rotation axis of Joint #1.

For details on the coordinate system, refer to the Epson RC+ Users Guide manual.

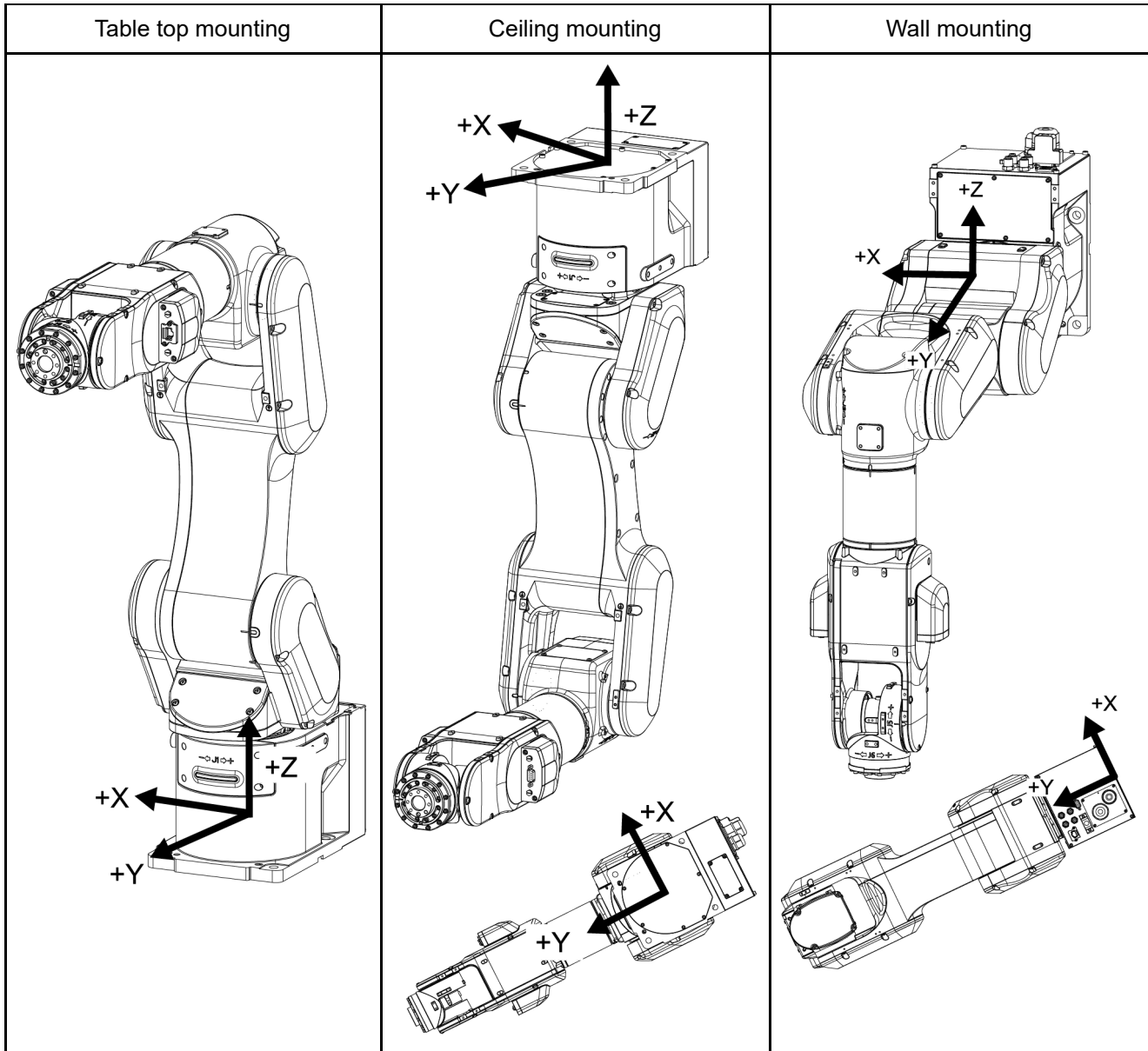

BASE setting is suitable for install the robot obliquely.

BASE setting can change a specific coordinate system of the robot and match the World coordinate system of the Jog & Teach and the coordinate system of the equipment.

For procedure of the BASE setting, refer to SPEL+ Language Reference: BASE Command.

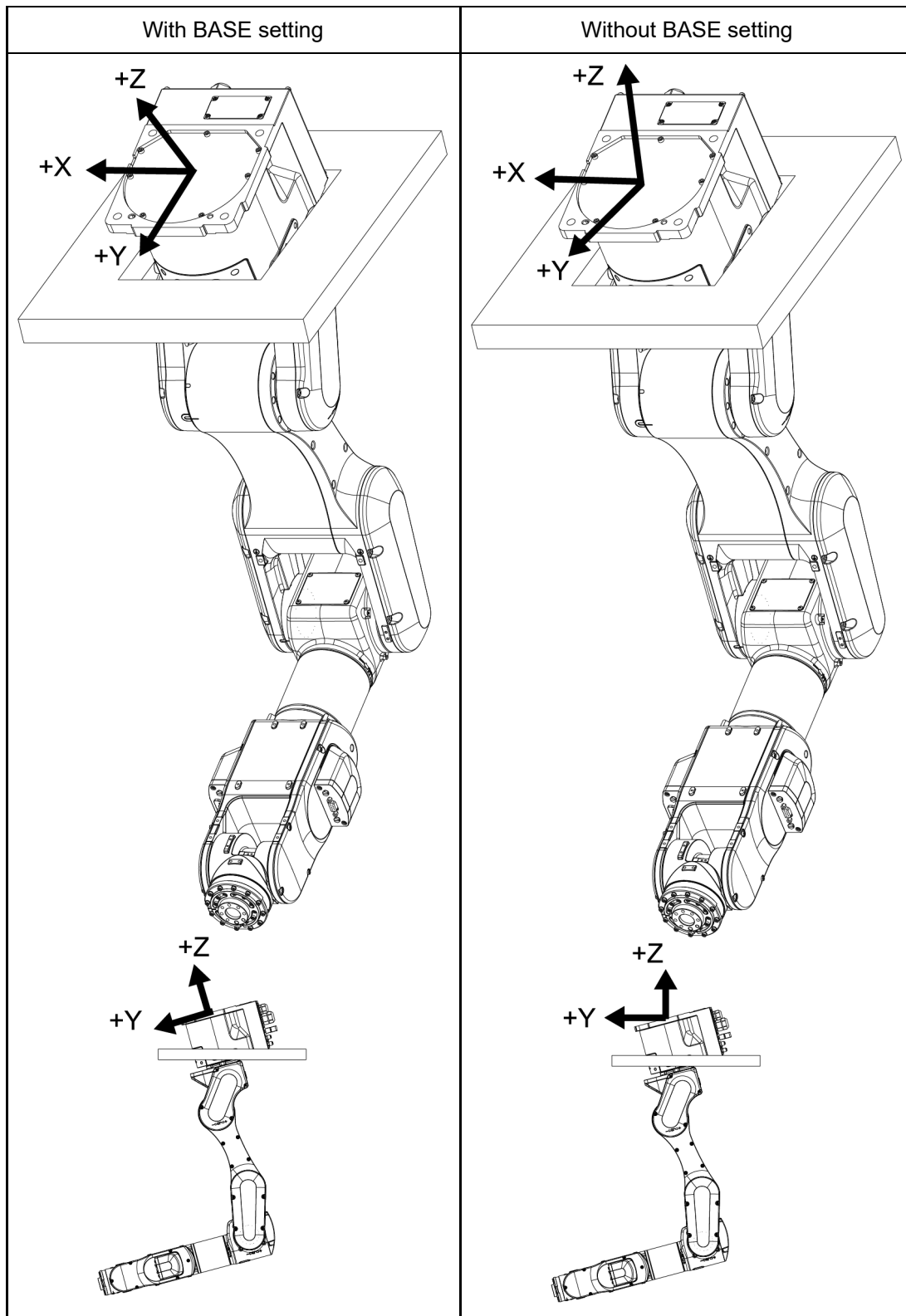

### 3.5.5 Changing the Robot

This section describes how to change the Manipulator model on Epson RC+.

**⚠ CAUTION**

Changing the Manipulator should be done with great caution. It initializes the robot calibration parameters (Hofs, CalPIs), additional axis information, and PG parameter data. Before changing the robot, make sure to save the calibration data by following the procedure below.

1. Select the Epson RC+ menu-[Setup]-[System Configuration].
2. Select [Controller]-[Robots]-[Robot\*\*]-[Calibration] from the tree list. Then, click [Save].

1. Select the Epson RC+ menu-[Setup]-[System Configuration].
2. Select [Controller]-[Robots]-[Robot\*\*] from the tree list. (Dialog image: Epson RC+ 8.0)

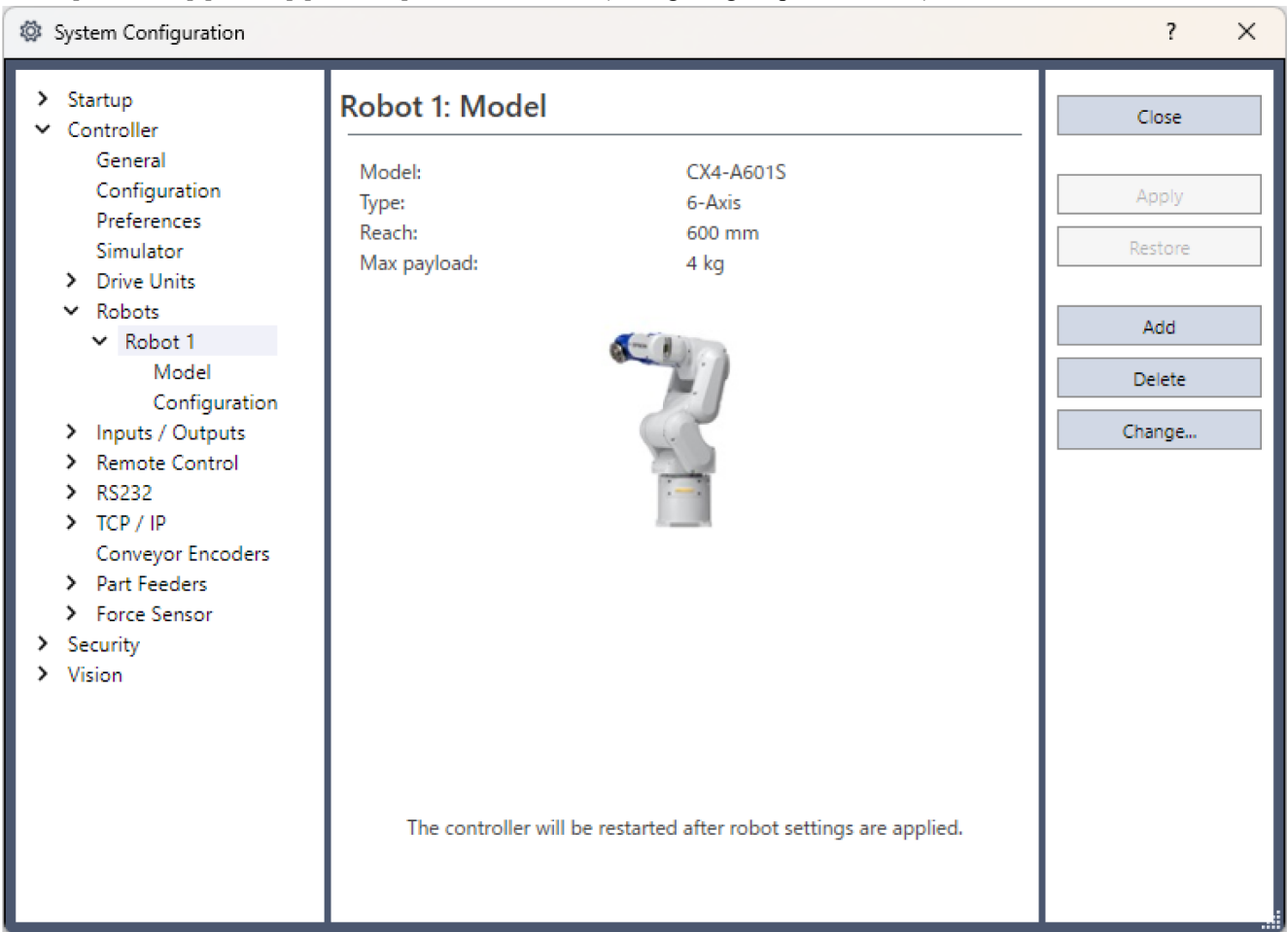

3. Click the [Change] button. The following dialog box will be displayed.

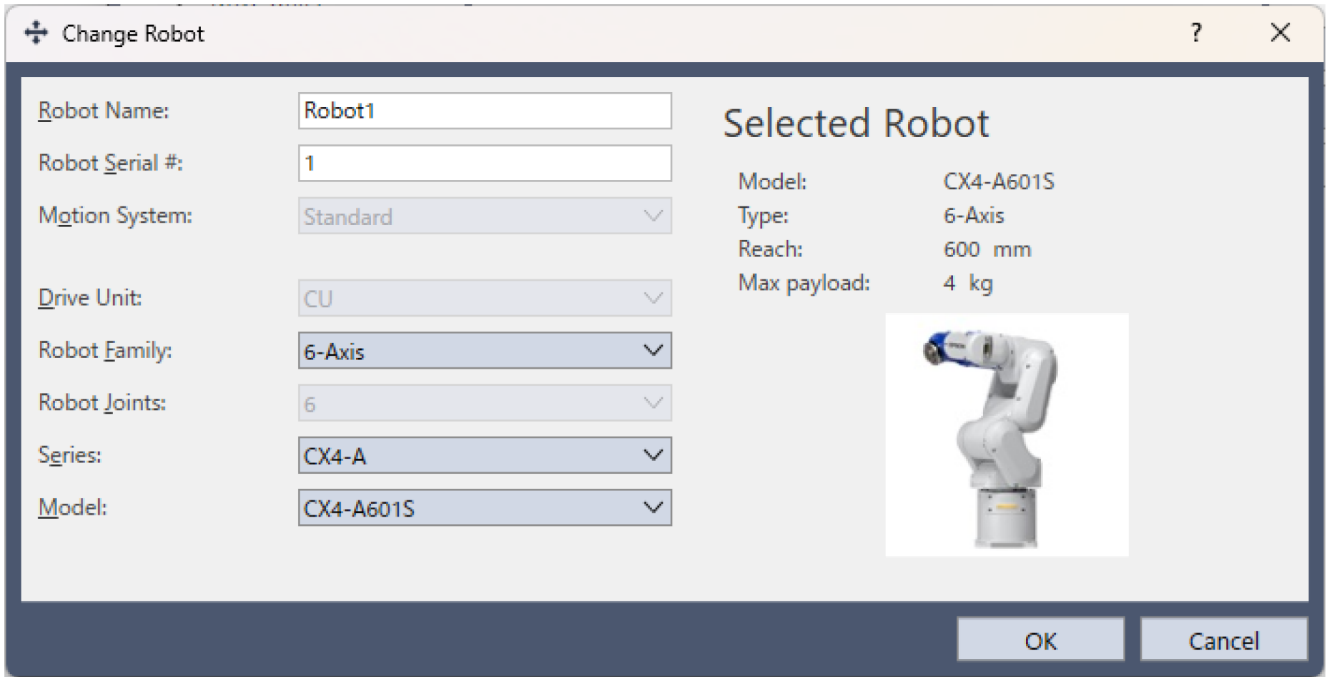

4. Input the robot name and serial number printed on the name plate of the Manipulator. Any serial number can be entered. However, enter the number printed on the Manipulator.
5. Select the robot type in the [Robot type] box.
6. Select the series name of the Manipulator in the [Series] box.
7. Select the robot model in the [Model] box.  
Available robots will be displayed according to the format of the currently installed motor driver. When [Dry run] is used, all the Manipulators of the series selected in Step 6 will be displayed.
8. Click the [OK] button. The Controller is restarted.

### 3.5.6 Setting the Rectangular Range in the XY Coordinate System of the Manipulator

The Cartesian (rectangular) range in the XY coordinate system of the Manipulator is specified by the limited Manipulator operation area and the XYLIM setting. The limited Manipulator operation area is defined so that the hand does not interfere with the rear side of the Manipulator. The XYLIM setting that you can determines the upper and lower limits of the X and Y coordinates.

These settings are software-based limit, and so it does not change the maximum physical range. The maximum physical range is based on the position of the mechanical stops.

These settings are disabled during a joint jogging operation. Therefore, be careful not to allow the hand to collide with the Manipulator or peripheral equipment.

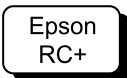

Go to [Tools] - [Robot Manager] - [XYZ Limits] panel, and make the setting. This can also be set using the XYLim statement in [Command Window].

## 3.6 Options

Options for the CX7 series Manipulator are the same as those for the CX4 series. Refer to the following:

- **Brake Release Unit**
- **Camera Plate Unit**
- **C4 Compatible Flange**
- **Variable Mechanical Stop**
- **External Wiring Kit**
- **User Wires and Pneumatic Tubes**

## 4. Periodic Inspection

Accurate inspection work is necessary to prevent breakdowns and ensure safety. This section explains the inspection schedule and what should be inspected.

Perform inspections according to the predetermined schedule.

## 4.1 CX4 Manipulator Periodic Inspection

Accurate inspection work is necessary to prevent breakdowns and ensure safety. This section explains the inspection schedule and what should be inspected.

Perform inspections according to the predetermined schedule.

### 4.1.1 Inspection

#### 4.1.1.1 Inspection Schedule

Inspection items are divided into five stages (daily, 1-month, 3-month, 6-month, and 12-month), with additional items added at each stage. However, if the Manipulator is powered and operated for more than 250 hours in a month, add inspection items every 250, 750, 1500, and 3000 hours.

	Inspection Item					
	Daily Inspection	1-month Inspection	3-month Inspection	6-month Inspection	12-month Inspection	Overhaul (Parts Replacement)
1 months (250 hours)	Perform daily	✓				
2 months (500 hours)		✓				
3 months (750 hours)		✓	✓			
4 months (1,000 hours)		✓				
5 months (1,250 hours)		✓				
6 months (1,500 hours)		✓	✓	✓		
7 months (1,750 hours)		✓				
8 months (2,000 hours)		✓				
9 months (2,250 hours)		✓	✓			
10 months (2,500 hours)		✓				
11 months (2,750 hours)		✓				
12 months (3,000 hours)		✓	✓	✓	✓	
13 months (3,250 hours)		✓				
⋮	⋮	⋮	⋮	⋮	⋮	⋮

	Inspection Item					
	Daily Inspection	1-month Inspection	3-month Inspection	6-month Inspection	12-month Inspection	Overhaul (Parts Replacement)
(20,000 hours)						✓

### 4.1.1.2 Inspection Details

#### Inspection items

Inspection Item	Inspection Location	Daily Inspection	1-month Inspection	3-month Inspection	6-month Inspection	12-month Inspection
Check for loose or rattling bolts	Hand mounting bolts	✓	✓	✓	✓	✓
	Manipulator installation bolts	✓	✓	✓	✓	✓
Check for loose connectors	Manipulator side external (connector plate, etc.)	✓	✓	✓	✓	✓
Inspect for flaws: Clean off adhering debris, etc.	Entire Manipulator	✓	✓	✓	✓	✓
	External cables		✓	✓	✓	✓
Correct deformations and misalignments	Safety barriers, etc.	✓	✓	✓	✓	✓
Check either the external short connector or the brake release unit connector is connected	The external short connector on the back side of the Manipulator, or the brake release unit connector	✓	✓	✓	✓	✓
Check brake operation	Brake for Joint #1 to #6	✓	✓	✓	✓	✓
Check for abnormal operation noise and vibration	Entire Manipulator	✓	✓	✓	✓	✓

#### Inspection methods

Inspection Item	Inspection Method
Check for loose or rattling bolts	Using an Allen wrench or similar tool, check that the hand mounting bolts and Manipulator installation bolts are not loose. If the bolts are loose, refer to the following section, and retighten to the proper torque. <b>Tightening the Hexagon Socket Head Cap Bolts</b>
Check for loose connectors	Check that no connectors are loose. If a connector is loose, reattach it so that it will not come off.
Inspect for flaws: Clean off adhering debris, etc.	Check the appearance of the Manipulator, and clean off any dust or other foreign substances adhering to it. Check the appearance of the cables for any flaws, and make sure it is not disconnected.

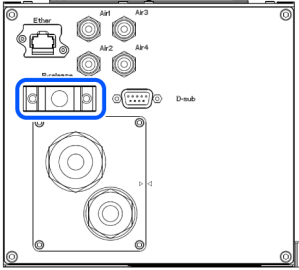
Inspection Item	Inspection Method
Correct deformations and misalignments	Check for misalignment of safety barriers and other components. If it is misaligned, correct it to the original position.
Check either the external short connector or the brake release unit connector is connected	<p>Check either the external short connector or the brake release unit connector is connected. When it is not connected, connect it.</p> 
Check brake operation	With the motor turned off, check that the arm does not drop. If the arm drops while the motor is turned off and the brake is not released, contact the supplier.
Check for abnormal operation noise and vibration	Check for any abnormal noises and vibrations during operation. If you notice anything unusual, contact the supplier.

### 4.1.2 Overhaul (Parts Replacement)

Overhaul (replacement) shall be performed by properly trained service engineers.

For details, refer to the following manual.

"Safety Manual - Role and Training for Safety Managers"

### 4.1.3 Applying Grease

The reduction gear units and the bevel gear need greasing regularly.

**⚠ CAUTION**

- Be careful that the grease does not run out. When grease runs out, scratches and other defects can occur on the slide, not only hindering maximum performance, but also requiring significant time and money to repair.
- If grease enters the eyes or mouth or adheres to the skin, take the following measures:
  - If it enters the eyes  
After rinsing the eyes thoroughly with clean water, seek medical attention.
  - If it enters the mouth  
If swallowed, do not force vomiting, and seek medical attention. If the mouth is contaminated, rinse thoroughly with water.
  - If adhered to skin  
Rinse with water and soap.

	Part	Interval	Safety Information
All joints	Reduction gear	When overhaul is performed	Applying grease can only be performed by properly trained service engineers. For more information, please contact the supplier.
Joint #6	Bevel gear		

### 4.1.4 Tightening the Hexagon Socket Head Cap Bolts

Hexagon socket head cap bolts (referred to as "bolts" below) are used in locations where mechanical strength is required. During assembly, these bolts are tightened at the tightening torques shown in the following table.

Unless otherwise specified, when retightening these bolts in the work procedures described in this manual, use a torque wrench or similar tool to obtain the tightening torques in the following table.

Bolt	Tightening Torque
M3	2.0 ± 0.1 N·m (21 ± 1 kgf·cm)
M4	4.0 ± 0.2 N·m (41 ± 2 kgf·cm)
M5	8.0 ± 0.4 N·m (82 ± 4 kgf·cm)
M6	13.0 ± 0.6 N·m (133 ± 6 kgf·cm)
M8	32.0 ± 1.6 N·m (326 ± 16 kgf·cm)
M10	58.0 ± 2.9 N·m (590 ± 30 kgf·cm)
M12	100.0 ± 5.0 N·m (1,020 ± 51 kgf·cm)

For set screw, refer to the following table.

Set Screw	Tightening Torque
M4	2.4 ± 0.1 N·m (26 ± 1 kgf·cm)
M5	3.9 ± 0.2 N·m (40 ± 2 kgf·cm)

It is recommended that bolts arranged in a circular pattern be secured in place by tightening in criss-cross order as shown in the figure.

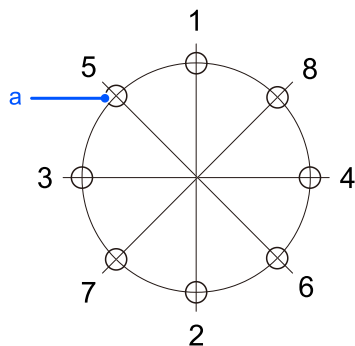

Symbol	Description
a	Threaded holes

When securing the bolts, do not tighten the bolts all at once, but tighten them in two or three separate rounds with an Allen wrench, and then use a torque wrench or similar tool to secure them at the tightening torques shown in the table above.

## 4.2 CX7 Manipulator Periodic Inspection

Accurate inspection work is necessary to prevent breakdowns and ensure safety. This section explains the inspection schedule and what should be inspected.

Perform inspections according to the predetermined schedule.

### 4.2.1 Inspection

#### 4.2.1.1 Inspection Schedule

Inspection items are divided into five stages (daily, 1-month, 3-month, 6-month, and 12-month), with additional items added at each stage. However, if the Manipulator is powered and operated for more than 250 hours in a month, add inspection items every 250, 750, 1500, and 3000 hours.

	Inspection Item					
	Daily Inspection	1-month Inspection	3-month Inspection	6-month Inspection	12-month Inspection	Overhaul (Parts Replacement)
1 months (250 hours)	Perform daily	✓				
2 months (500 hours)		✓				
3 months (750 hours)		✓	✓			
4 months (1,000 hours)		✓				
5 months (1,250 hours)		✓				
6 months (1,500 hours)		✓	✓	✓		
7 months (1,750 hours)		✓				
8 months (2,000 hours)		✓				
9 months (2,250 hours)		✓	✓			
10 months (2,500 hours)		✓				
11 months (2,750 hours)		✓				
12 months (3,000 hours)		✓	✓	✓	✓	
13 months (3,250 hours)		✓				
⋮	⋮	⋮	⋮	⋮	⋮	⋮

	Inspection Item					
	Daily Inspection	1-month Inspection	3-month Inspection	6-month Inspection	12-month Inspection	Overhaul (Parts Replacement)
(20,000 hours)						✓

### 4.2.1.2 Inspection Details

#### Inspection items

Inspection Item	Inspection Location	Daily Inspection	1-month Inspection	3-month Inspection	6-month Inspection	12-month Inspection
Check for loose or rattling bolts	Hand mounting bolts	✓	✓	✓	✓	✓
	Manipulator installation bolts	✓	✓	✓	✓	✓
Check for loose connectors	Manipulator side external (connector plate, etc.)	✓	✓	✓	✓	✓
Inspect for flaws: Clean off adhering debris, etc.	Entire Manipulator	✓	✓	✓	✓	✓
	External cables		✓	✓	✓	✓
Correct deformations and misalignments	Safety barriers, etc.	✓	✓	✓	✓	✓
Check either the external short connector or the brake release unit connector is connected	The external short connector on the back side of the Manipulator, or the brake release unit connector	✓	✓	✓	✓	✓
Check brake operation	Brake for Joint #1 to #6	✓	✓	✓	✓	✓
Check for abnormal operation noise and vibration	Entire Manipulator	✓	✓	✓	✓	✓

#### Inspection methods

Inspection Item	Inspection Method
Check for loose or rattling bolts	Using an Allen wrench or similar tool, check that the hand mounting bolts and Manipulator installation bolts are not loose. If the bolts are loose, refer to the following section, and retighten to the proper torque. <b>Tightening the Hexagon Socket Head Cap Bolts</b>
Check for loose connectors	Check that no connectors are loose. If a connector is loose, reattach it so that it will not come off.
Inspect for flaws: Clean off adhering debris, etc.	Check the appearance of the Manipulator, and clean off any dust or other foreign substances adhering to it. Check the appearance of the cables for any flaws, and make sure it is not disconnected.

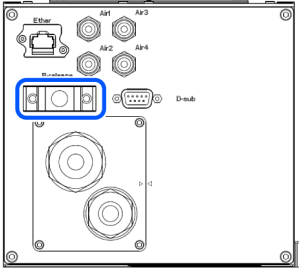
Inspection Item	Inspection Method
Correct deformations and misalignments	Check for misalignment of safety barriers and other components. If it is misaligned, correct it to the original position.
Check either the external short connector or the brake release unit connector is connected	<p>Check either the external short connector or the brake release unit connector is connected. When it is not connected, connect it.</p> 
Check brake operation	With the motor turned off, check that the arm does not drop. If the arm drops while the motor is turned off and the brake is not released, contact the supplier.
Check for abnormal operation noise and vibration	Check for any abnormal noises and vibrations during operation. If you notice anything unusual, contact the supplier.

### 4.2.2 Overhaul (Parts Replacement)

Overhaul (replacement) shall be performed by properly trained service engineers.

For details, refer to the following manual.

"Safety Manual - Role and Training for Safety Managers"

### 4.2.3 Applying Grease

The reduction gear units and the bevel gear need greasing regularly.

**⚠ CAUTION**

- Be careful that the grease does not run out. When grease runs out, scratches and other defects can occur on the slide, not only hindering maximum performance, but also requiring significant time and money to repair.
- If grease enters the eyes or mouth or adheres to the skin, take the following measures:
  - If it enters the eyes  
After rinsing the eyes thoroughly with clean water, seek medical attention.
  - If it enters the mouth  
If swallowed, do not force vomiting, and seek medical attention. If the mouth is contaminated, rinse thoroughly with water.
  - If adhered to skin  
Rinse with water and soap.

	Part	Interval	Safety Information
All joints	Reduction gear	When overhaul is performed	Applying grease can only be performed by properly trained service engineers. For more information, please contact the supplier.
Joint #6	Bevel gear		

### 4.2.4 Tightening the Hexagon Socket Head Cap Bolts

Hexagon socket head cap bolts (referred to as "bolts" below) are used in locations where mechanical strength is required. During assembly, these bolts are tightened at the tightening torques shown in the following table.

Unless otherwise specified, when retightening these bolts in the work procedures described in this manual, use a torque wrench or similar tool to obtain the tightening torques in the following table.

Bolt	Tightening Torque
M3	2.0 ± 0.1 N·m (21 ± 1 kgf·cm)
M4	4.0 ± 0.2 N·m (41 ± 2 kgf·cm)
M5	8.0 ± 0.4 N·m (82 ± 4 kgf·cm)
M6	13.0 ± 0.6 N·m (133 ± 6 kgf·cm)
M8	32.0 ± 1.6 N·m (326 ± 16 kgf·cm)
M10	58.0 ± 2.9 N·m (590 ± 30 kgf·cm)
M12	100.0 ± 5.0 N·m (1,020 ± 51 kgf·cm)

For set screw, refer to the following table.

Set Screw	Tightening Torque
M4	2.4 ± 0.1 N·m (26 ± 1 kgf·cm)
M5	3.9 ± 0.2 N·m (40 ± 2 kgf·cm)
M6	8.0 ± 0.4 N·m (82 ± 4 kgf·cm)

It is recommended that bolts arranged in a circular pattern be secured in place by tightening in criss-cross order as shown in the figure.

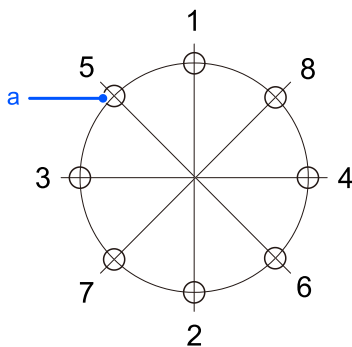

Symbol	Description
a	Threaded holes

---

When securing the bolts, do not tighten the bolts all at once, but tighten them in two or three separate rounds with an Allen wrench, and then use a torque wrench or similar tool to secure them at the tightening torques shown in the table above.

## 5. Appendix

This section provides detailed technical data such as the specifications, stopping time, and stopping distance for each model.

## 5.1 Appendix A: Specifications Table

### 5.1.1 CX4 Specifications

Item		Specifications
		CX4-A601***
Machinery name		Industrial robot
Product series		CX-A
Model		CX4-A601\ *** <b>Model Number</b>
Model Name		CX4
Mounting type * 1		Table top mounting, Ceiling mounting, Wall mounting
Arm length	P point: J1 to J5 center	601.6 mm
Maximum reach	J1 to J6 flange	674.1 mm
Manipulator weight (not include the weight of cables or shipping jigs)		Standard (- NIW), cleanroom (- NIW) specifications: 30 kg: 66.1 lb Standard, cleanroom specification, Protected (- NIW) Model: 31kg: 68.3 lb Protected-Model: 32 kg: 70.5 lb
Drive system	All joints	AC servo motor
Maximum operating speed * 2	Joint #1	450°/s
	Joint #2	450°/s
	Joint #3	514°/s
	Joint #4	558°/s
	Joint #5	570°/s
	Joint #6	851°/s
Maximum synthetic speed		10206 mm/s
Repeatability *3	Joint #1 to #6	±0.01 mm
Maximum motion range	Joint #1	±180°
	Joint #2	-155~ +67°
	Joint #3	-63~+193°
	Joint #4	±270°
	Joint #5	±135°
	Joint #6	±540° *4

Item		Specifications
		CX4-A601***
Max. pulse range (pulse)	Joint #1	±5029027
	Joint #2	-4432617 to +1916035
	Joint #3	-1520140 to +4656929
	Joint #4	±6332848
	Joint #5	±3104337
	Joint #6	±8311862
Resolution	Joint #1	0.0000358°/pulse
	Joint #2	0.0000350°/pulse
	Joint #3	0.0000414°/pulse
	Joint #4	0.0000426°/pulse
	Joint #5	0.0000435°/pulse
	Joint #6	0.0000650°/pulse
Motor rated capacity	Joint #1	400 W
	Joint #2	400 W
	Joint #3	400 W
	Joint #4	100 W
	Joint #5	50 W
	Joint #6	50 W
Payload (load) * 5	Rated	1 kg
	Maximum	4 kg (5 kg with arm downward positioning)
Allowable moment	Joint #4	8.86 N·m (0.90 kgf·m)
	Joint #5	8.86 N·m (0.90 kgf·m)
	Joint #6	4.90 N·m (0.50 kgf·m)
Allowable moment of inertia *6 (GD <sup>2</sup> /4)	Joint #4	0.20 kg·m <sup>2</sup>
	Joint #5	0.20 kg·m <sup>2</sup>
	Joint #6	0.10 kg·m <sup>2</sup>
User wires (Excluding NIW specifications)		9 wires (D-sub) 8Pin (RJ45) equivalent to Cat.5e
User wires * 7		ø4 mm pneumatic tube 4 Pressure resistance: 0.59 MPa (6 kgf/cm <sup>2</sup> ) (86 psi)

Item		Specifications	
		CX4-A601***	
Environmental requirements * 8	Ambient temperature	5~40°C *9	
	Ambient relative humidity	10 to 80% RH (no condensation)	
	Vibration	4.9 m/s <sup>2</sup> (0.5 G) or less	
Transportation and storage	Temperature	-20~+60°C	
	Humidity	10 to 90% (no condensation)	
Noise level * 10		LAeq = 73.4 dB or lower	
Environmental Specifications		Standard *11 Cleanroom & ESD (anti-static) * 11 Protection (IP67) *12	
Compatible Controller		RC800-A	
M/C cable	Cable weight (cable only)	For fixing and signal (common to all lengths)	0.06 kg/m
		For fixing and power (common to all lengths)	0.45 kg/m
		For movable and signal (common to all lengths)	0.07 kg/m
		For movable and power (common to all lengths)	0.52 kg/m
	Cable outer diameter	For fixing and signal (common to all lengths)	ø6.2 mm (typ)
		For fixing and power (common to all lengths)	ø17.8 mm (typ)
		For movable and signal (common to all lengths)	ø6.4 mm (typ)
		For movable and power (common to all lengths)	ø17.8 mm (typ)
	Minimum bending radius * 13	For fixing and signal (common to all lengths)	38 mm
		For fixing and power (common to all lengths)	107 mm
		For movable and signal (common to all lengths)	100 mm
		For movable and power (common to all lengths)	100 mm
Operation mode *14		Operation mode (default), boost mode	

Item		Specifications
		CX4-A601***
Default value Inside ( ) is the maximum setting value	Speed	5 (100)
	Accel *15	5, 5 (100, 100)
	SpeedS	50 (2000)
	AccelS	200 (25000)
	Fine	10000, 10000, 10000, 10000, 10000, 10000 (65535, 65535, 65535, 65535, 65535, 65535)
	Weight	1 (5)
	Inertia	0.005 (0.1)

\*1: Manipulators are set to "Table Top mounting" or "Wall mounting" at shipment. To use the Manipulators as "Ceiling mounting", you need to change the model settings.

- **Changing the Robot**
- "Epson RC+ User's Guide - Robot Configuration"

\*2: When PTP statements are used

\*3: The value described below are ones that were obtained through individual test conditions. Therefore, it is likely to change depending on the usage environment and conditions.

\*4: Always contact the supplier if you wish to set it to a higher range than the one previously mentioned.

\*5: If the payload exceeds the maximum payload, refer to the following section.

**"WEIGHT Setting** - Restrictions on payload exceeding the maximum payload"

\*6: If the center of gravity is at the center of each arm.

If the center of gravity is not at the center of each arm, set the eccentricity using INERTIA command.

\*7: For details of the installed pneumatic tube for customer use, refer to the following section.

#### **User Wires and Pneumatic Tubes**

\*8: For details of the environmental requirements, refer to the following section.

#### **Environment**

\*9: When used in a low-temperature environment near the minimum temperature specified in the product specifications, or when the unit is idle for a long period of time during holidays or at night, a collision detection error or similar error may occur immediately after the start of operation due to high resistance in the drive unit. In such cases, warm-up operation for about 10 minutes is recommended.

\*10: The conditions at measurement are as follows.

- Operating conditions: Under rated load, all arms simultaneous motion, maximum speed, and maximum acceleration/deceleration which duty is 100%.
- Measurement point: 1000 mm apart from the rear of Manipulator

\*11: Manipulators with cleanroom specifications discharge the exhaust inside of the base and inside of the arm cover section together. Consequently, if there is a gap in the base section, the arm tip section will not be sufficiently negatively pressurized, which may result in dust generation.

- Cleanliness: Class ISO 3 (ISO 14644-1)

- Exhaust port: Fitting for  $\varnothing 12$  mm tube 60 L/min vacuum

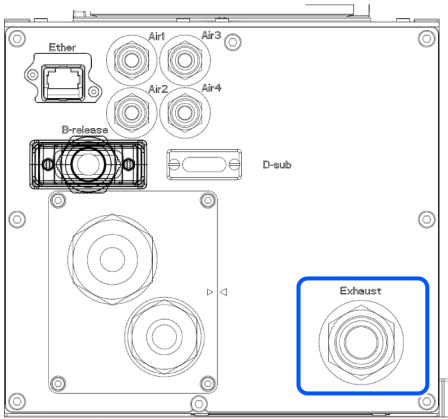

- Exhaust tube: Polyurethane tube Outer diameter:  $\varnothing 12$  mm

Cleanroom specification uses resin materials with anti-static treatment. This model controls adhesion of dust due to electrification.

Protection level for the standard model and cleanroom model Manipulators is equivalent to IP20.

The IP (International Protection) rating is an international standard indicating the degree of protection against dust and water.

Protection Class		
IP20	Dust protection level: 2	A solid object which is 12.5 mm or longer cannot touch dangerous areas inside of the Manipulator.
	Water protection level: 0	Not protected.

\*12: Protection level for the protected-model Manipulators is IP67 (IEC standard). The Manipulators can be used in environments where the possibility of dust, water, and water-soluble cutting oil falling of the Manipulator exists. Note the following points.

- The Manipulator is not rust-proofed. Do not use the Manipulator in environment where corrosive liquids exist.
- Fluids that deteriorate the sealing materials, such as organic solvents, acids, alkalis, and chlorine cutting fluids, cannot be used.
- The Manipulator cannot be used for underwater operations.
- The Controller does not have protection features against the environment (Controller’s protection level: IP20). Make sure to install the system where environmental requirements for the Controller are satisfied.
- Be sure to connect a connector compliant with protection class IP67 or higher and a connector cover to the Ethernet cable connector.

The IP (International Protection) rating is an international standard indicating the degree of protection against dust and water.

Protection Class		
IP67	Dust protection level: 6	A testing rod which is 1.0 mm or longer cannot touch dangerous areas inside of the Manipulator. Totally protected against dust.
	Water protection level: 7	Water cannot enter the Manipulator when the Manipulator is immersed in water for 30 minutes under the condition that the highest point of the Manipulator is located 0.15 m below the surface of the water and the lowest point is located 1 m below the surface of the water. (The Manipulator is stopped during the test.)

\*13: Note the following points when wiring the movable M/C cable.

- Install the cable not to apply a load to the connector.
- Bend the cable at the minimum bending radius of the movable part or more. The bending radius (a) and dimensions are shown in the figure below.

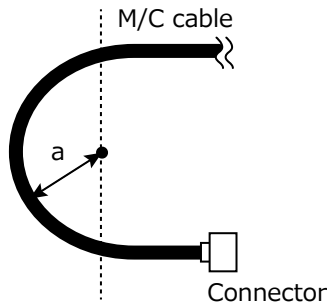

\*14: The operation mode can be switched with the PerformMode command. For details, refer to the following manual.  
"Epson RC+ SPEL+ Language Reference"

### KEY POINTS

Compared to the standard mode, the operation time will be shorter for the boost mode but the vibration during the operation stopping time will get worse.

### CAUTION

Keep in mind that J1/J2/J3 moves at the same time during boost mode. When the following conditions are met simultaneously, the lifespan of the reduction gear unit may get shorter.

- J1 motion stroke > 90°
- J2+J3 motion stroke > 90°
- Swinging motion when J3 moves with a 90° pose.

J3=90° pose example:

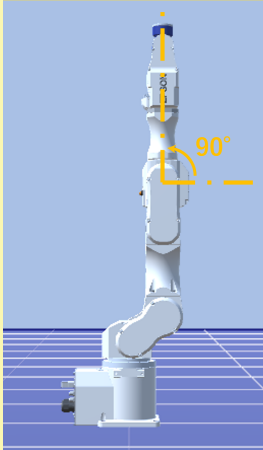

Operation example:

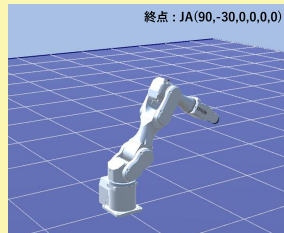
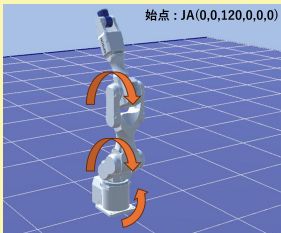

\*15: The Accel setting of "100" is the optimum setting that balances acceleration/deceleration and vibration during positioning.

### 5.1.2 CX7 Specifications

Item		Specifications	
		CX7-A701\ ***	CX7-A901***
Machinery name		Industrial robot	
Product series		CX-A	
Model		CX7-A701\ *** <b>Model Number</b>	CX7-A901\ *** <b>Model Number</b>
Model Name		CX7	CX7L
Mounting type * \ 1		Table top mounting, Ceiling mounting, Wall mounting	
Arm length	P point: J1 to J5 center	701.3 mm	901.0 mm
Maximum reach	J1 to J6 flange	782.8 mm	982.5 mm
Manipulator weight (not include the weight of cables or shipping jigs)		Standard (- NIW), cleanroom (- NIW) specifications: 32 kg: 70.5 lb Standard, cleanroom specification, Protected (- NIW) Model 33 kg: 72.8 lb Protected-Model: 34 kg: 75.0 lb	Standard (-NIW) model, cleanroom (-NIW) model: 33kg: 72.8 lb Standard, cleanroom specification, Protected (- NIW) Model 35 kg: 77.2 lb Protected-Model: 36 kg: 79.4 lb
Drive system	All joints	AC servo motor	
Maximum operating speed * 2	Joint #1	414°/s	332°/s
	Joint #2	389°/s	312°/s
	Joint #3	487°/s	390°/s
	Joint #4	558°/s	
	Joint #5	547°/s	
	Joint #6	851°/s	
Maximum synthetic speed		10811 mm/s	10916 mm/s
Repeatability *3	Joint #1 to #6	±0.015 mm	±0.02 mm
Maximum motion range	Joint #1	±180°	
	Joint #2	-155°~+67°	
	Joint #3	-63°~+193°	
	Joint #4	±270°	
	Joint #5	±135°	
	Joint #6	±540° *4	

Item		Specifications	
		CX7-A701\ ***	CX7-A901***
Max. pulse range (pulse)	Joint #1	±5620677	±7008498
	Joint #2	-5540771 to +2395044	-6908863 to +2986412
	Joint #3	-1520139 to +4656929	-1895480 to +5806788
	Joint #4	±6332848	
	Joint #5	±3104337	
	Joint #6	±8311862	
Resolution	Joint #1	0.0000320°/pulse	0.0000257°/pulse
	Joint #2	0.0000280°/pulse	0.0000224°/pulse
	Joint #3	0.0000414°/pulse	
	Joint #4	0.0000426°/pulse	
	Joint #5	0.0000435°/pulse	
	Joint #6	0.0000650°/pulse	
Motor rated capacity	Joint #1	400 W	
	Joint #2	400 W	
	Joint #3	400 W	
	Joint #4	100 W	
	Joint #5	100 W	
	Joint #6	100 W	
Payload (load) * 5	Rated	3 kg	
	Maximum	7 kg	
Allowable moment	Joint #4	16.9 N·m (1.72 kgf·m)	
	Joint #5	16.9 N·m (1.72 kgf·m)	
	Joint #6	9.4 N·m (0.96 kgf·m)	
Allowable moment of inertia *6 (GD <sup>2</sup> /4)	Joint #4	0.49 kg·m <sup>2</sup>	
	Joint #5	0.49 kg·m <sup>2</sup>	
	Joint #6	0.15 kg·m <sup>2</sup>	
User wires (Excluding NIW specifications)		9 wires (D-sub) 8Pin (RJ45) equivalent to Cat.5e	
User wires * 7		ø4 mm pneumatic tube 4 Pressure resistance: 0.59 MPa (6 kgf/cm <sup>2</sup> ) (86 psi)	
Environmental requirements * 8	Ambient temperature	5~40°C *9	
	Ambient relative humidity	10 to 80% RH (no condensation)	

Item		Specifications	
		CX7-A701\ ***	CX7-A901***
	Vibration	4.9 m/s <sup>2</sup> (0.5 G) or less	
Transportation and storage	Temperature	-20~+60°C	
	Humidity	10 to 90% (no condensation)	
Noise level * 10		LAeq = 71.2 dB (A) or lower	LAeq = 69.3 dB (A) or lower
Environmental Specifications		Standard *11 Cleanroom & ESD (anti-static) * 11 Protection (IP67) *12	
Compatible Controller		RC800-A	
M/C cable	Cable weight (cable only)	For fixing and signal (common to all lengths)	0.06 kg/m
		For fixing and power (common to all lengths)	0.45 kg/m
		For movable and signal (common to all lengths)	0.07 kg/m
		For movable and power (common to all lengths)	0.52 kg/m
	Cable outer diameter	For fixing and signal (common to all lengths)	ø6.2 mm (typ)
		For fixing and power (common to all lengths)	ø17.8 mm (typ)
		For movable and signal (common to all lengths)	ø6.4 mm (typ)
		For movable and power (common to all lengths)	ø17.8 mm (typ)
	Minimum bending radius * 13	For fixing and signal (common to all lengths)	38 mm
		For fixing and power (common to all lengths)	107 mm
		For movable and signal (common to all lengths)	100 mm

Item			Specifications	
			CX7-A701\ ***	CX7-A901***
		For movable and power (common to all lengths)	100 mm	
Operation mode *14			Operation mode (default), boost mode	
Default value Maximum setting values inside ( )	Speed		5 (100)	
	Accel *15		5, 5 (100, 100)	
	SpeedS		50 (2000)	
	AccelS *16		200 (20000)	200 (16000)
	Fine		10000, 10000, 10000, 10000, 10000, 10000 (65535, 65535, 65535, 65535, 65535, 65535)	
	Weight		3 (7)	
	Inertia		0.03 (0.15)	

\*1: Manipulators are set to "Table Top mounting" or "Wall mounting" at shipment. To use the Manipulators as "Ceiling mounting", you need to change the model settings.

- **Changing the Robot**
- "Epson RC+ User's Guide - Robot Configuration"

\*2: When PTP statements are used

\*3: The value described below are ones that were obtained through individual test conditions. Therefore, it is likely to change depending on the usage environment and conditions.

\*4: Always contact the supplier if you wish to set it to a higher range than the one previously mentioned.

\*5: If the payload exceeds the maximum payload, refer to the following section.

**"WEIGHT Setting - Restrictions on payload exceeding the maximum payload"**

\*6: If the center of gravity is at the center of each arm.

If the center of gravity is not at the center of each arm, set the eccentricity using INERTIA command.

\*7: For details of the installed pneumatic tube for customer use, refer to the following section.

**User Wires and Pneumatic Tubes**

\*8: For details of the environmental requirements, refer to the following section.

**Environment**

\*9: When used in a low-temperature environment near the minimum temperature specified in the product specifications, or when the unit is idle for a long period of time during holidays or at night, a collision detection error or similar error may occur immediately after the start of operation due to high resistance in the drive unit. In such cases, warm-up operation for about 10 minutes is recommended.

\*10: The conditions at measurement are as follows.

- Operating conditions: Under rated load, all arms simultaneous motion, maximum speed, and maximum acceleration/deceleration which duty is 100%.
- Measurement point: 1000 mm apart from the rear of Manipulator

\*11: Manipulators with cleanroom specifications discharge the exhaust inside of the base and inside of the arm cover section together. Consequently, if there is a gap in the base section, the arm tip section will not be sufficiently negatively pressurized, which may result in dust generation.

- Cleanliness: Class ISO 3 (ISO 14644-1)
- Exhaust port: Fitting for  $\varnothing 12$  mm tube 60 L/min vacuum

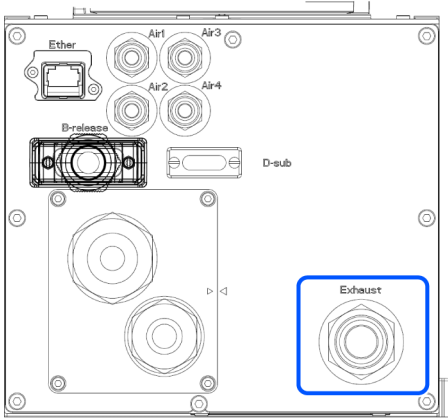

- Exhaust tube: Polyurethane tube Outer diameter:  $\varnothing 12$  mm

Cleanroom specification uses resin materials with anti-static treatment. This model controls adhesion of dust due to electrification.

Protection level for the standard model and cleanroom model Manipulators is equivalent to IP20.

The IP (International Protection) rating is an international standard indicating the degree of protection against dust and water.

Protection Class		
IP20	Dust protection level: 2	A solid object which is 12.5 mm or longer cannot touch dangerous areas inside of the Manipulator.
	Water protection level: 0	Not protected.

\*12: Protection level for the protected-model Manipulators is IP67 (IEC standard). The Manipulators can be used in environments where the possibility of dust, water, and water-soluble cutting oil falling of the Manipulator exists. Note the following points.

- The Manipulator is not rust-proofed. Do not use the Manipulator in environment where corrosive liquids exist.
- Fluids that deteriorate the sealing materials, such as organic solvents, acids, alkalis, and chlorine cutting fluids, cannot be used.
- The Manipulator cannot be used for underwater operations.
- The Controller does not have protection features against the environment (Controller’s protection level: IP20). Make sure to install the system where environmental requirements for the Controller are satisfied.
- Be sure to connect a connector compliant with protection class IP67 or higher and a connector cover to the Ethernet cable connector.

The IP (International Protection) rating is an international standard indicating the degree of protection against dust and water.

Protection Class		
IP67	Dust protection level: 6	A testing rod which is 1.0 mm or longer cannot touch dangerous areas inside of the Manipulator. Totally protected against dust.

Protection Class		
	Water protection level: 7	Water cannot enter the Manipulator when the Manipulator is immersed in water for 30 minutes under the condition that the highest point of the Manipulator is located 0.15 m below the surface of the water and the lowest point is located 1 m below the surface of the water. (The Manipulator is stopped during the test.)

\*13: Note the following points when wiring the movable M/C cable.

- Install the cable not to apply a load to the connector.
- Bend the cable at the minimum bending radius of the movable part or more. The bending radius (a) and dimensions are shown in the figure below.

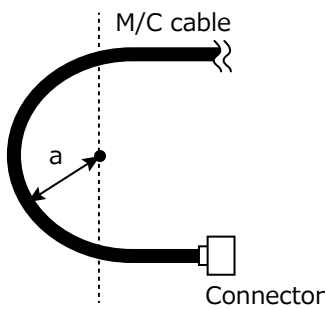

\*14: The operation mode can be switched with the PerformMode command. For details, refer to the following manual. "Epson RC+ SPEL+ Language Reference"

**KEY POINTS**

Compared to the standard mode, the operation time will be shorter for the boost mode but the vibration during the operation stopping time will get worse.

**CAUTION**

Keep in mind that J1/J2/J3 moves at the same time during boost mode. When the following conditions are met simultaneously, the lifespan of the reduction gear unit may get shorter.

- J1 motion stroke > 90°
- J2+J3 motion stroke > 90°
- Swinging motion when J3 moves with a 90° pose.

J3=90° pose example:

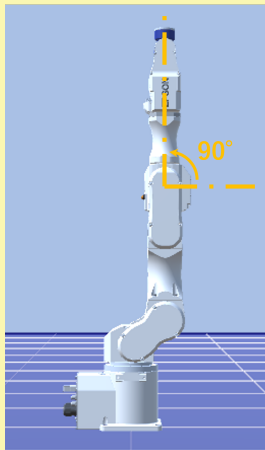

Operation example:

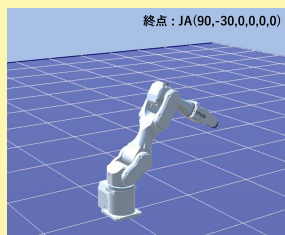
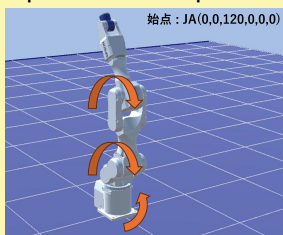

\*15: The Accel setting of "100" is the optimum setting that balances acceleration/deceleration and vibration during positioning.

\*16: Maximum AccelS setting value varies depending on the load. For details, refer to the following figure. Setting the value which exceeds the maximum AccelS causes an error. Check the setting value.

**Maximum AccelS setting value**

■ CX7-A701\*\*\*

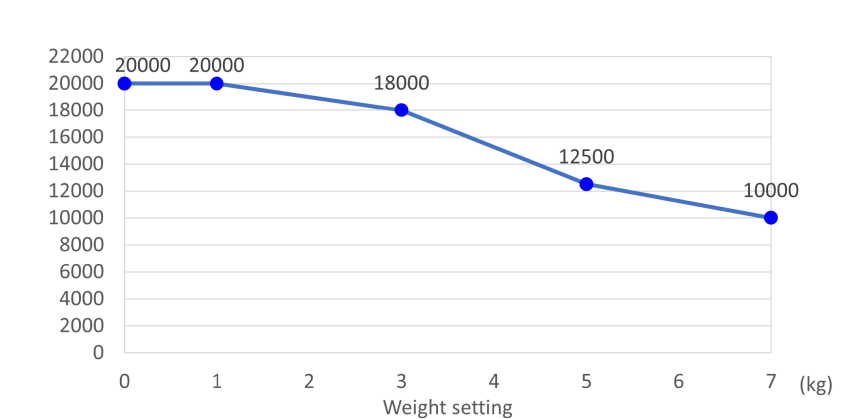

■ CX7-A901\*\*\*

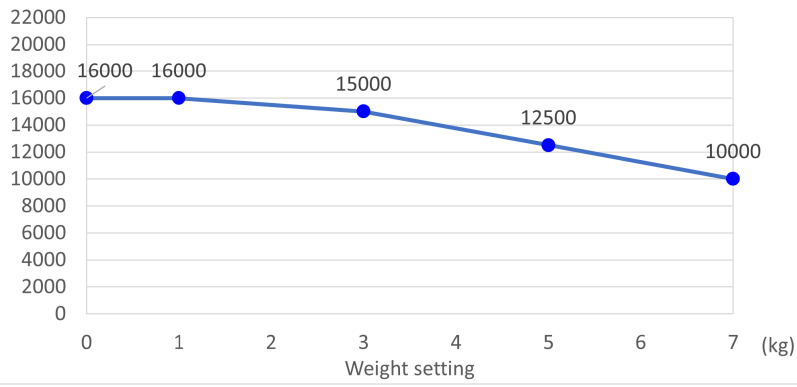

## 5.2 Appendix B: Stopping Time and Stopping Distance at Emergency Stop

The stopping time and stopping distance at an emergency stop are shown in the graphs for each model.

The stopping time is the length of time corresponding to the "Stopping time" in the figure below. Be sure to confirm that a safe environment is provided where the robot will be installed and operated.

For models equipped with a safety board such as RC800-A, the stopping time and stopping distance when using the Safety Limited Speed (SLS), Safety Limited Position (SLP), and Soft Axis Limiting are equivalent to those of the emergency stop.

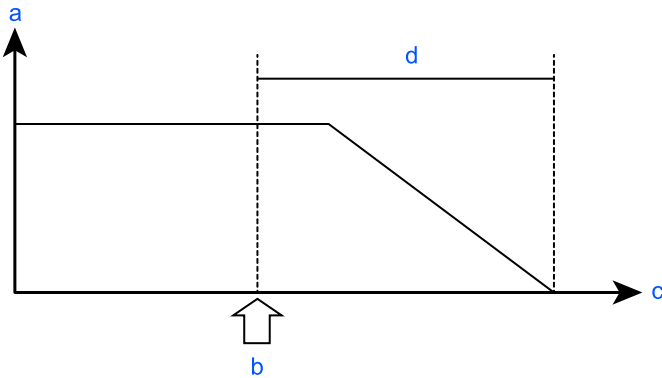

Symbol	Description
a	Motor speed
b	Emergency stop, Maximum Speed of SLS exceeded, monitoring areas and Joint Angle Limit of SLP exceeded, restricted range of Soft Axis Limiting exceeded
c	Time
d	Stopping time

Conditions:

The stopping time and stopping distance depend on the parameters (setting values) that were set for the robot. These graphs show the times and distances for the following parameters.

These conditions are based on the ISO 10218-1:2011 Annex B.

- Accel: 100, 100
- Speed: 100 %, 66 %, 33 % Settings
- Weight: 100 %, 66 %, 33 % of the maximum payload, rated payload\*1
- Arm elongation rate: 100 %, 66 %, 33 % \*2
- Other settings: Default
- Motion: Singular axis motion of a Go command \*3
- Input timing of the Stop signal: input with maximum speed. In this motion, it is the center of the motion range.

\*1: Weight: 5 kg has been added to the conditions because the CX4-A601 can grip 5 kg with the flange surface limited to ±30° in the direction of gravity.

\*2: Arm elongation rate: The arm elongation rate L is as shown below: The graphs indicate the results where the stopping time and the stopping distance in the longest among the arm elongation rates.

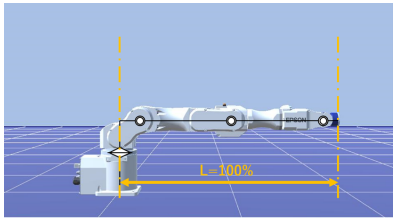
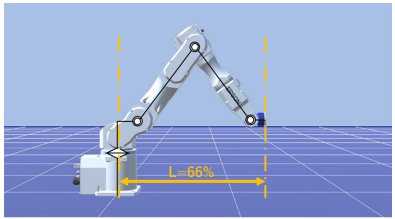
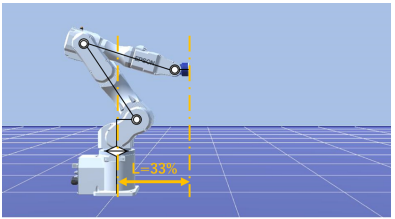
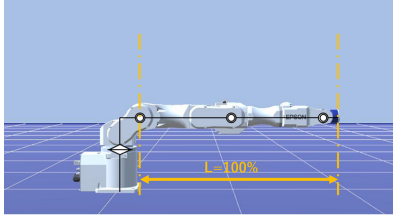
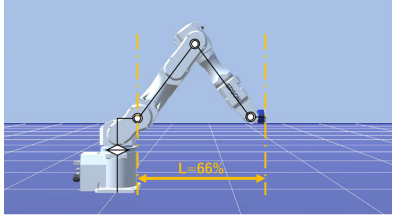
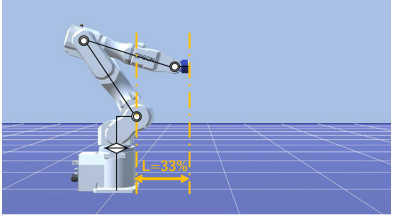
Axis	L=100%	L=66%	L=33%
J1			
J2			

\*3: Operation: The 5 kg condition for the CX4-A601\*\*\* requires operation with the flange surface within a range of  $\pm 30^\circ$  in the direction of gravity.

Explanation of legend:

The graphs are displayed for each Weight setting value (at 100%, approx. 66%, and approx. 33% of the maximum payload, and at the rated payload).

- Horizontal axis: Arm speed (Speed setting)
- Vertical axis: Stopping time and stopping distance at each arm speed
- Time (sec): Stopping time (sec)
- Distance (deg): stopping distance (degree)

When single failures are taken into account, the following adjustments are used.

- Stopping distance and angle: Each axis reaches the mechanical stop
- Stopping time: Add 500 ms

## 5.2.1 CX4-A Stopping Time and Stopping Distance at Emergency Stop

### CX4-A601\*\*\*: J1 (Table top mounting, Ceiling mounting)

Standard mode

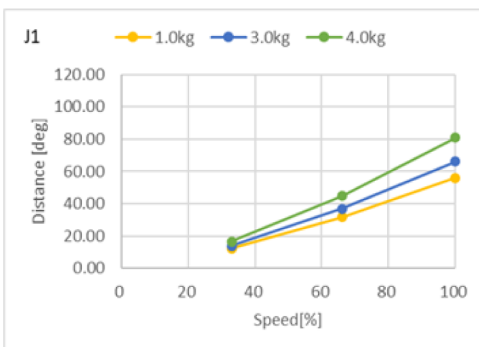
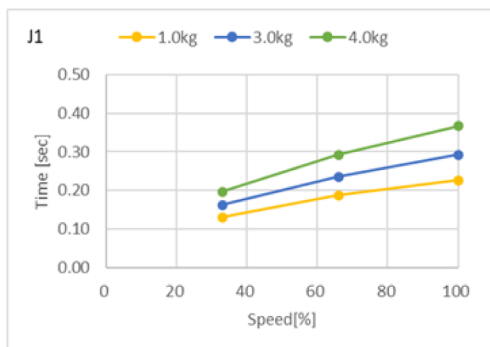

Boost mode

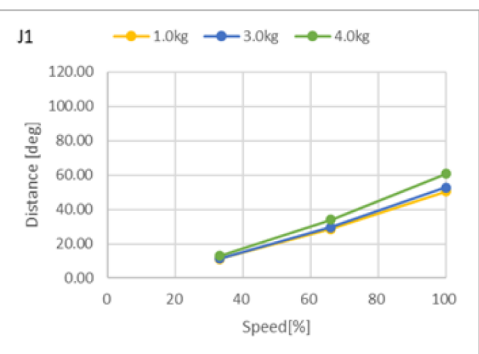
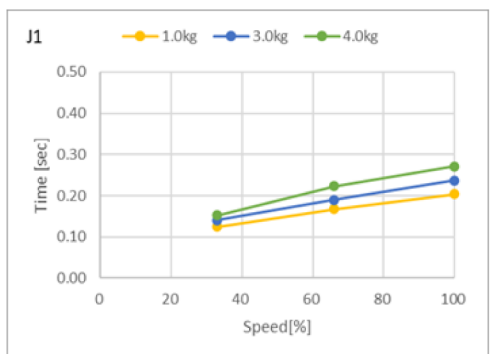

**CX4-A601\*\*\*: J1 (Wall mounting)**

Standard mode

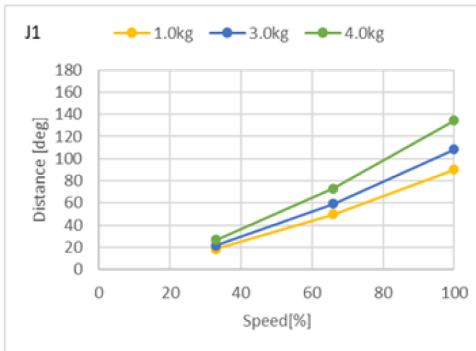
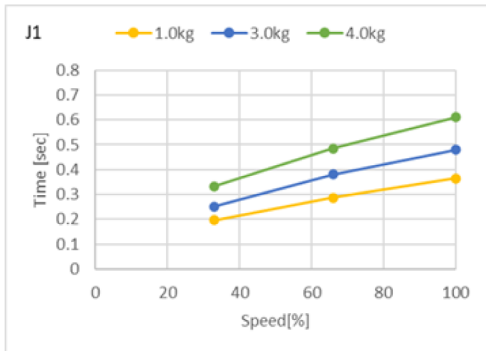

Boost mode

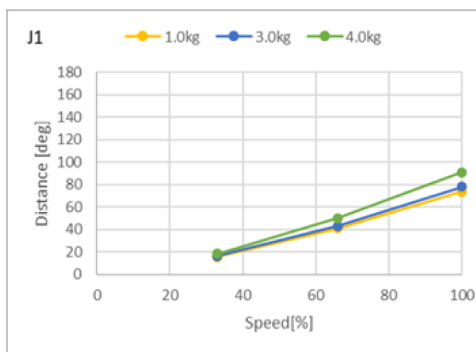
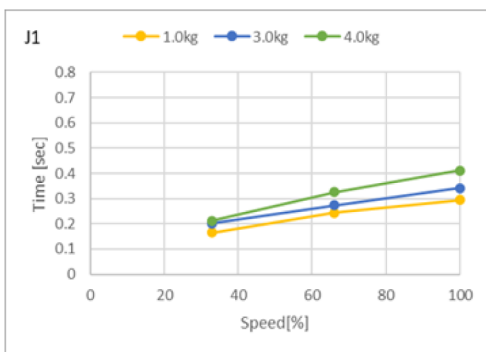

### CX4-A601\*\*\*: J2 (Table top mounting, Ceiling mounting, Wall mounting)

#### Standard mode

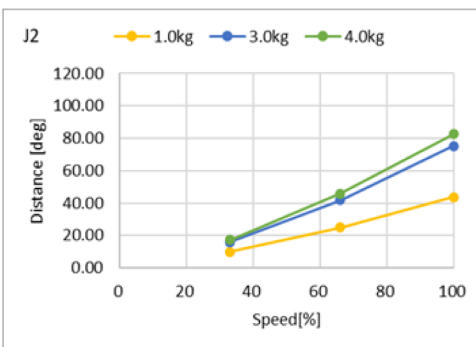
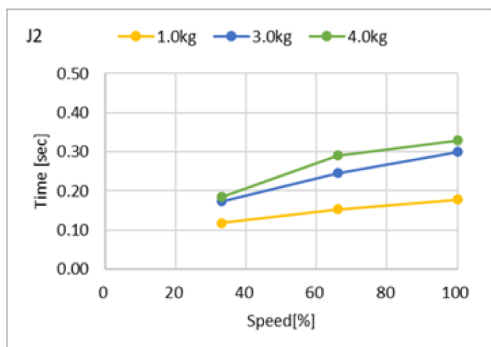

#### Boost mode

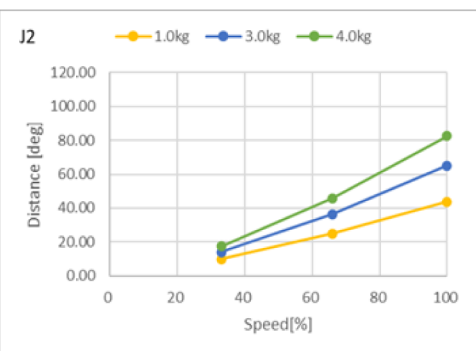
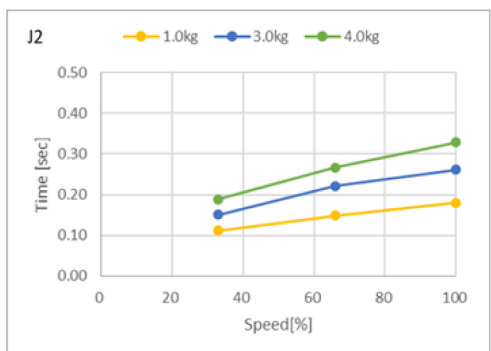

**CX4-A601\*\*\*: J3 (Table top mounting, Ceiling mounting, Wall mounting)**

Standard mode

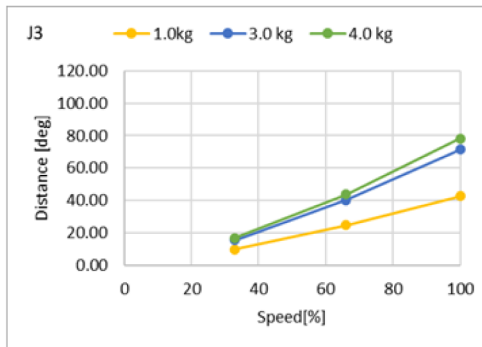
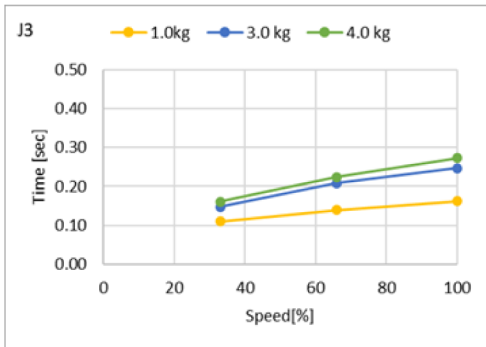

Boost mode

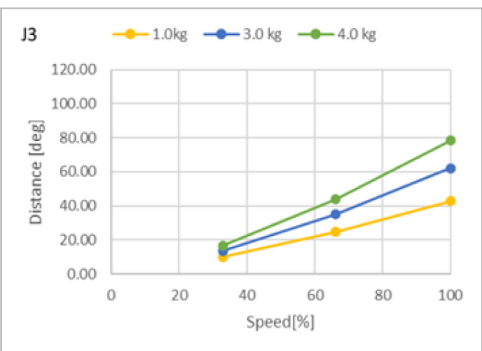
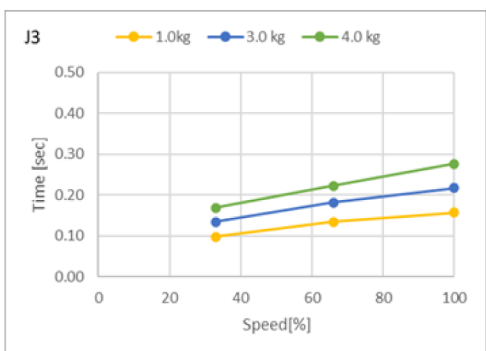

**CX4-A601\*\*\*: J4 (Table top mounting, Ceiling mounting, Wall mounting)**

Standard mode

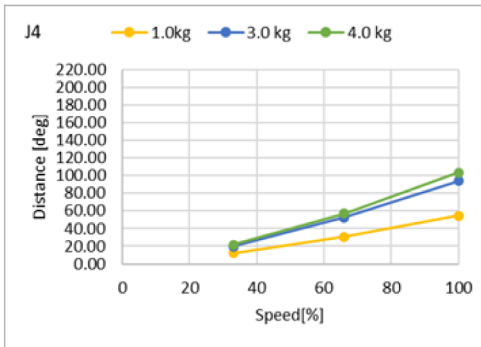
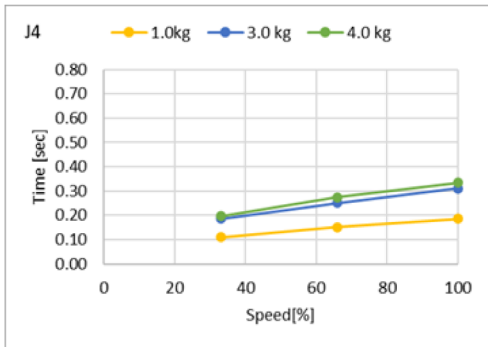

Boost mode

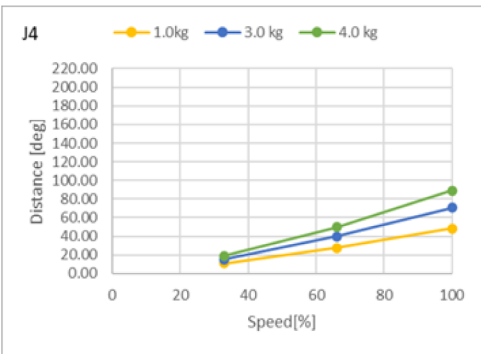
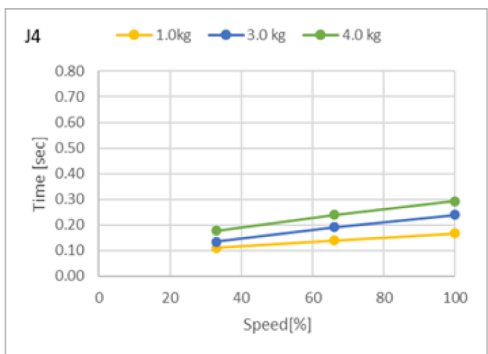

**CX4-A601\*\*\*: J5 (Table top mounting, Ceiling mounting, Wall mounting)**

Standard mode

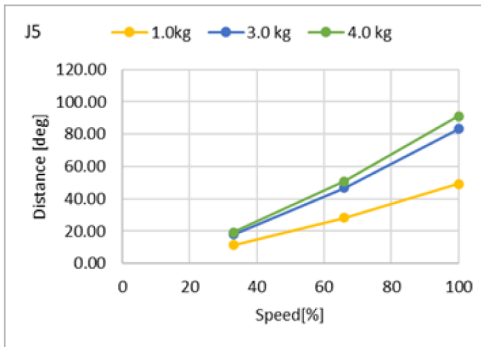
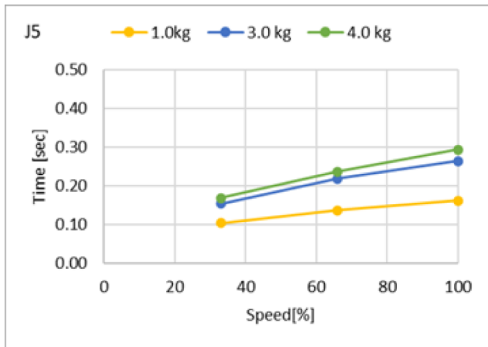

Boost mode

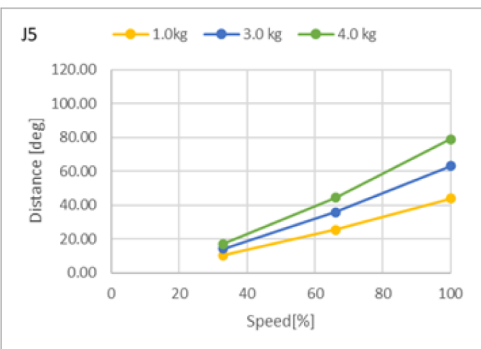
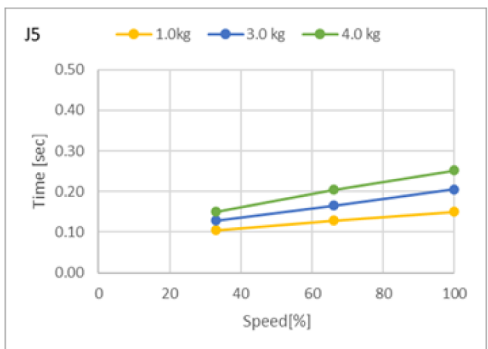

**CX4-A601\*\*\*: J6 (Table top mounting, Ceiling mounting, Wall mounting)**

Standard mode

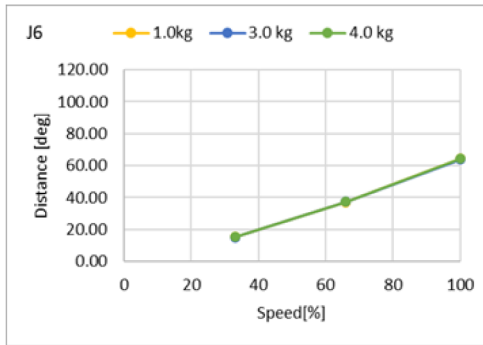
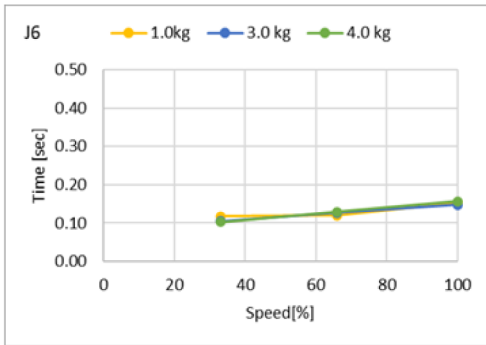

Boost mode

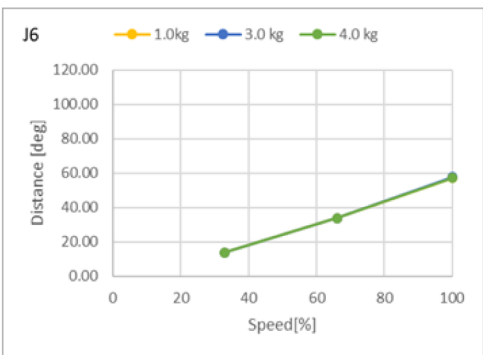
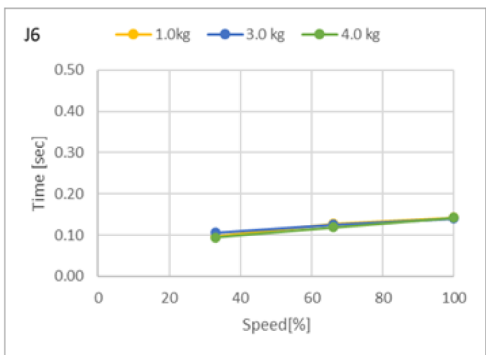

**CX4-A601\*\*\*: J1 (Table top mounting, Ceiling mounting)\_When grasping 5 kg**

Standard mode

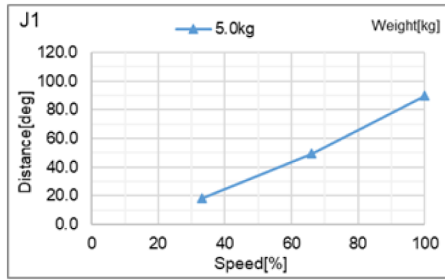
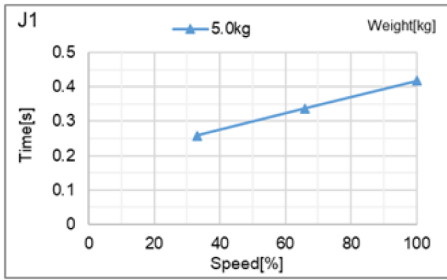

Boost mode

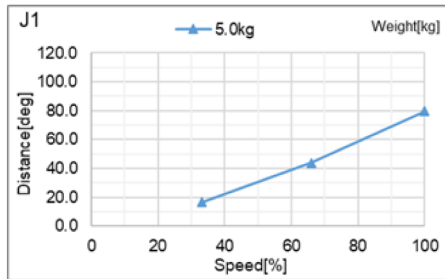
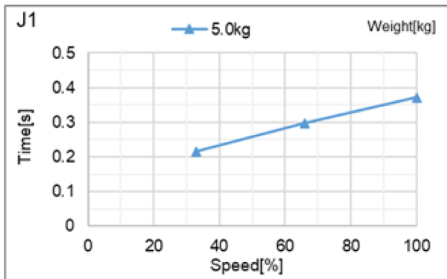

**CX4-A601\*\*\*: J1 (Wall mounting)\_When grasping 5 kg**

Standard mode

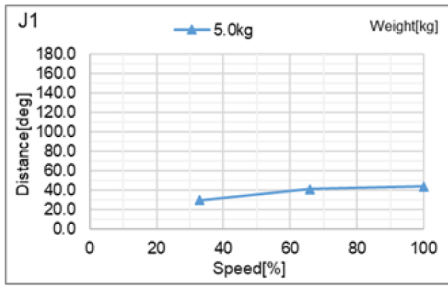
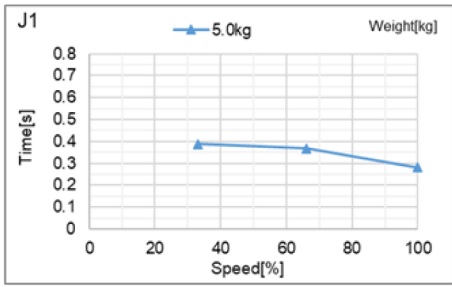

Boost mode

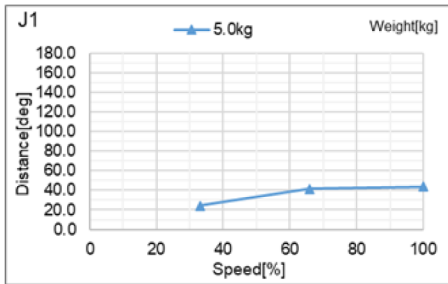
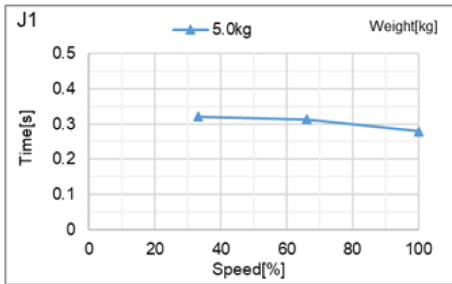

### CX4-A601\*\*\*: J2 (Table top mounting, Ceiling mounting)\_When grasping 5 kg

Standard mode

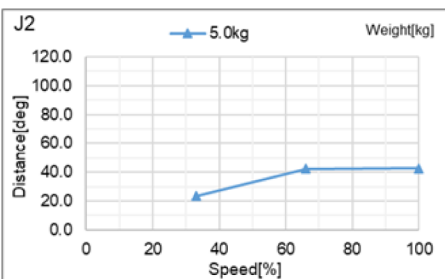
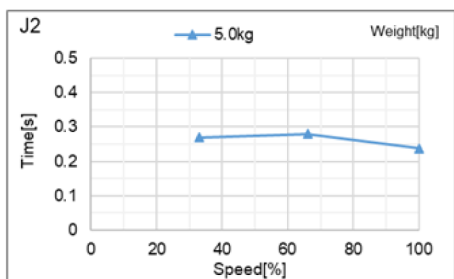

Boost mode

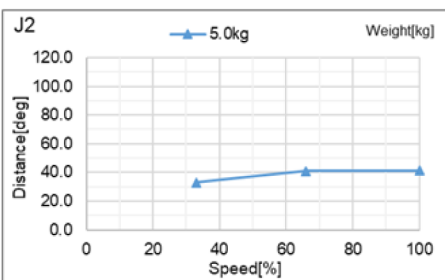
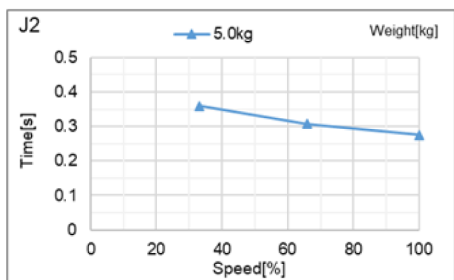

**CX4-A601\*\*\*: J2 (Wall mounting)\_When grasping 5 kg**

Standard mode

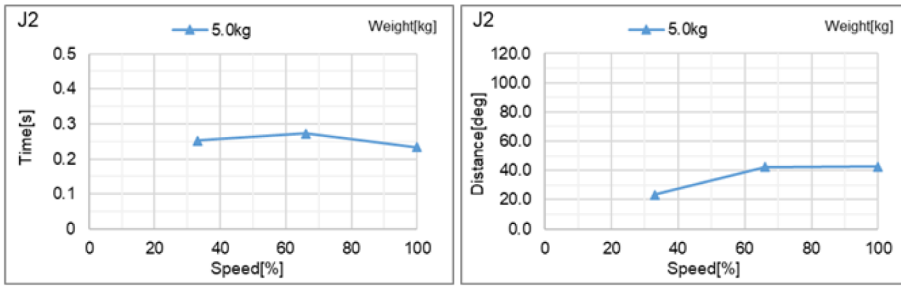

Boost mode

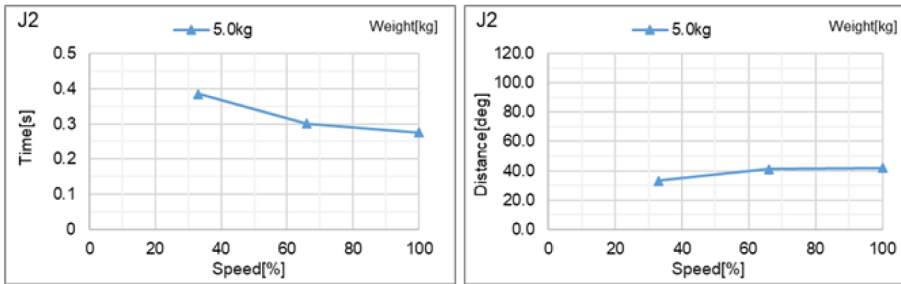

### CX4-A601\*\*\*: J3 (Table top mounting, Ceiling mounting)\_When grasping 5 kg

Standard mode

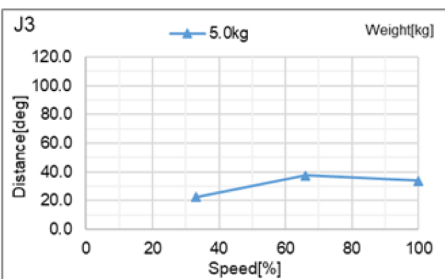
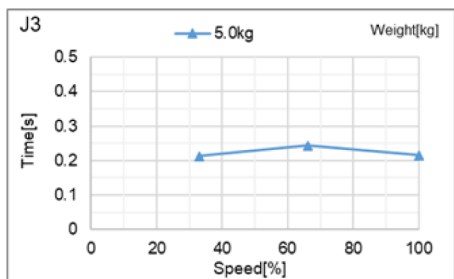

Boost mode

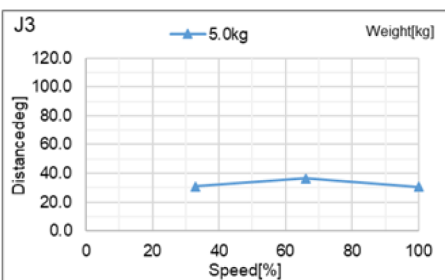
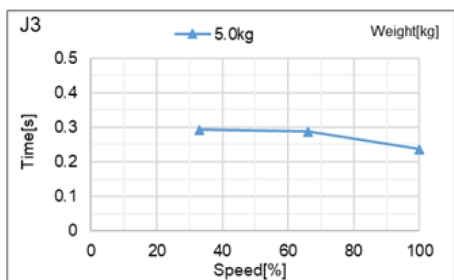

### CX4-A601\*\*\*: J3 (Wall mounting)\_When grasping 5 kg

Standard mode

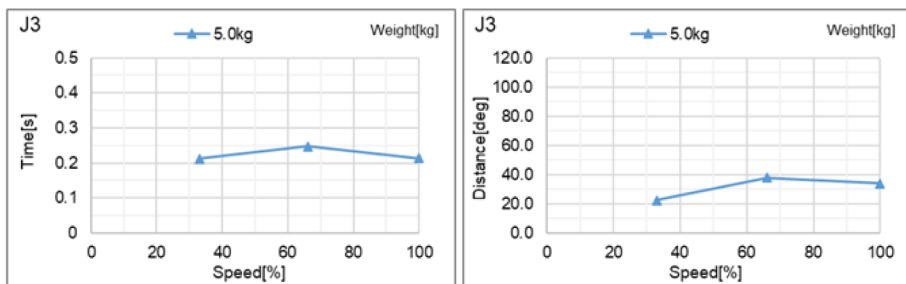

Boost mode

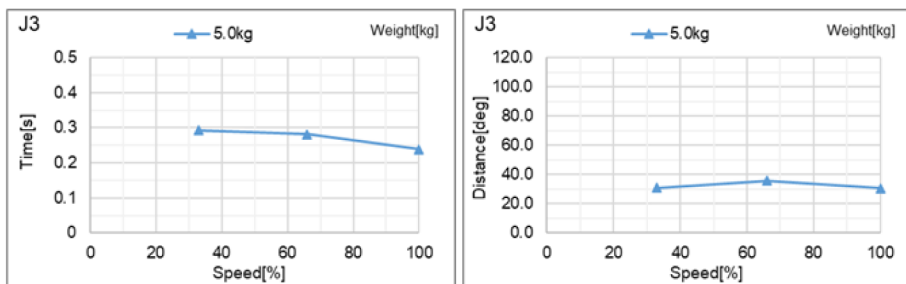

**CX4-A601\*\*\*: J4 (Table top mounting, Ceiling mounting)\_When grasping 5 kg**

Standard mode

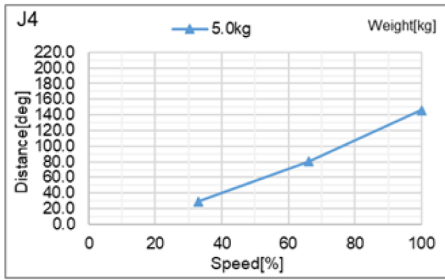
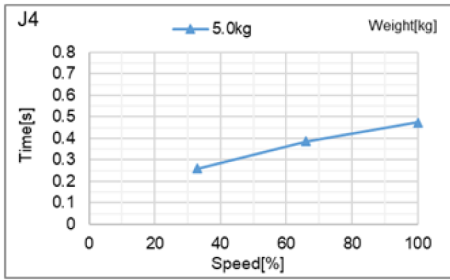

Boost mode

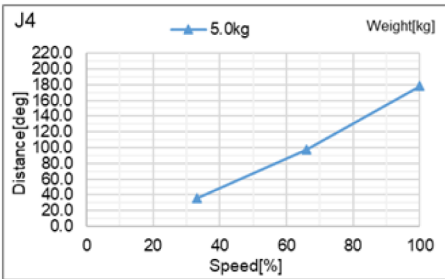
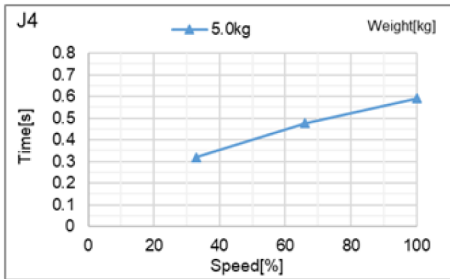

**CX4-A601\*\*\*: J4 (Wall mounting)\_When grasping 5 kg**

Standard mode

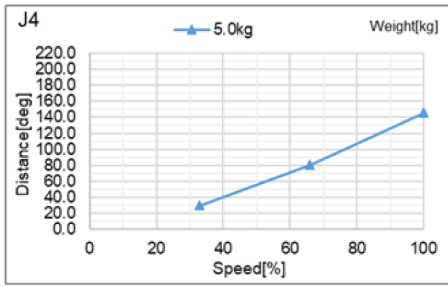
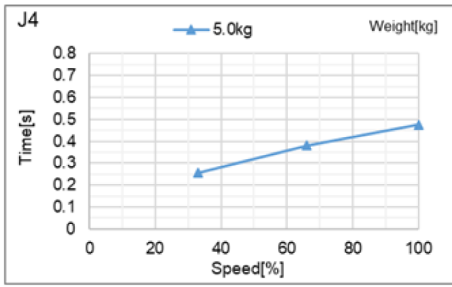

Boost mode

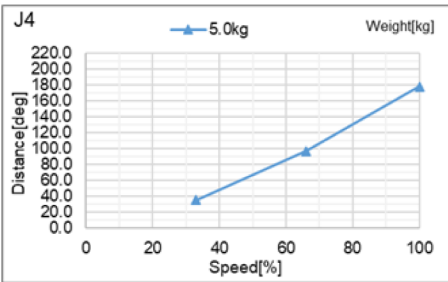
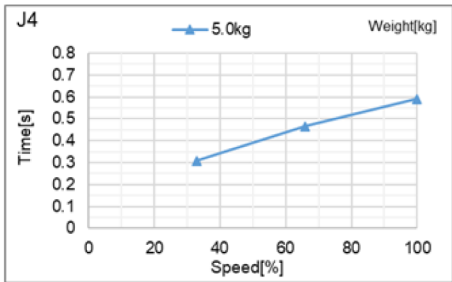

**CX4-A601\*\*\*: J5 (Table top mounting, Ceiling mounting)\_When grasping 5 kg**

Standard mode

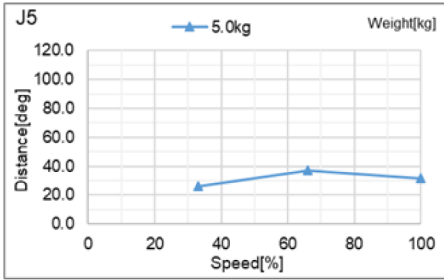
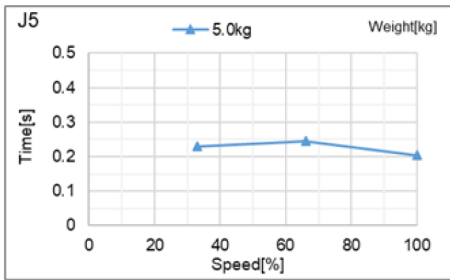

Boost mode

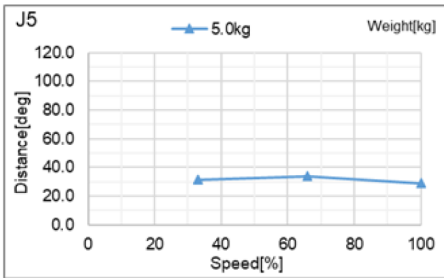
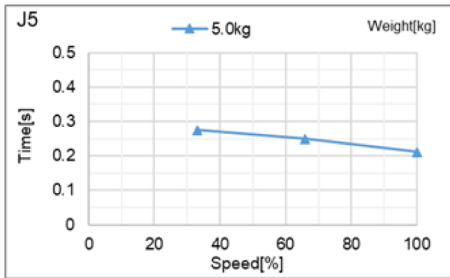

**CX4-A601\*\*\*: J5 (Wall mounting)\_When grasping 5 kg**

Standard mode

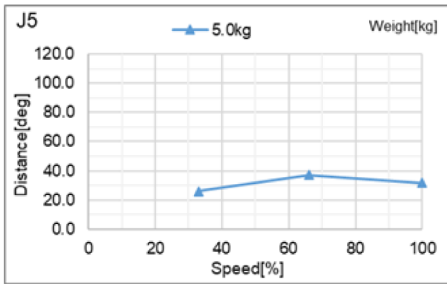
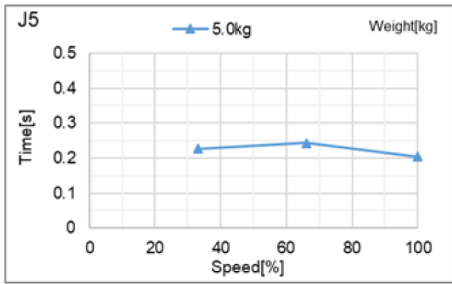

Boost mode

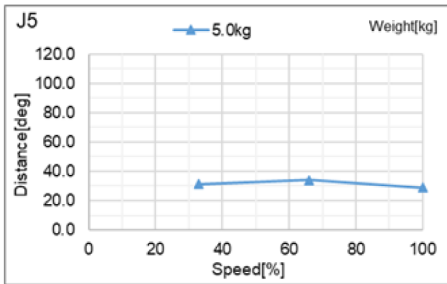
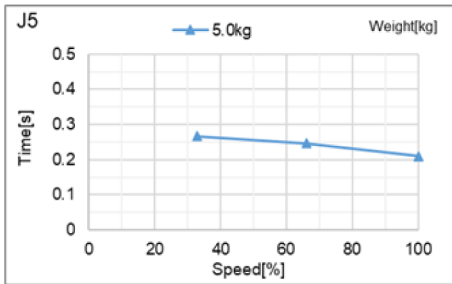

**CX4-A601\*\*\*: J6 (Table top mounting, Ceiling mounting)\_When grasping 5 kg**

Standard mode

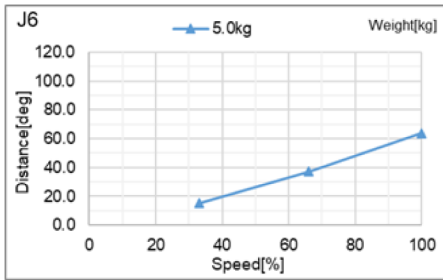
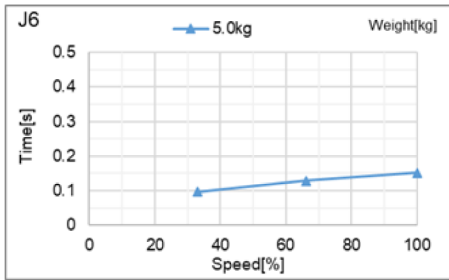

Boost mode

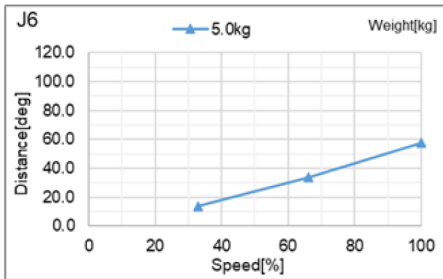
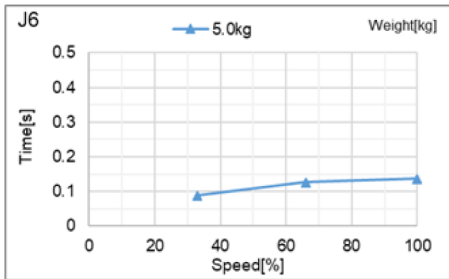

### CX4-A601\*\*\*: J6 (Wall mounting)\_When grasping 5 kg

Standard mode

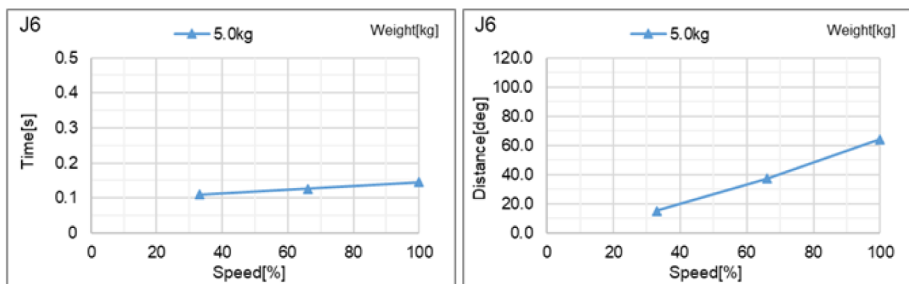

Boost mode

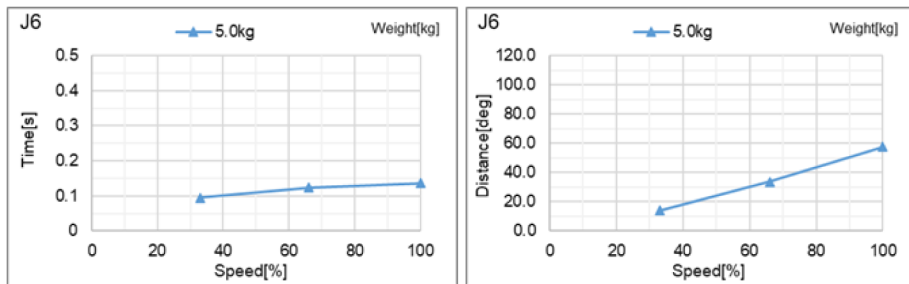

## 5.2.2 CX7-A Stopping Time and Stopping Distance at Emergency Stop

### CX7-A701\*\*\*: J1 (Table top mounting, Ceiling mounting)

#### Standard mode

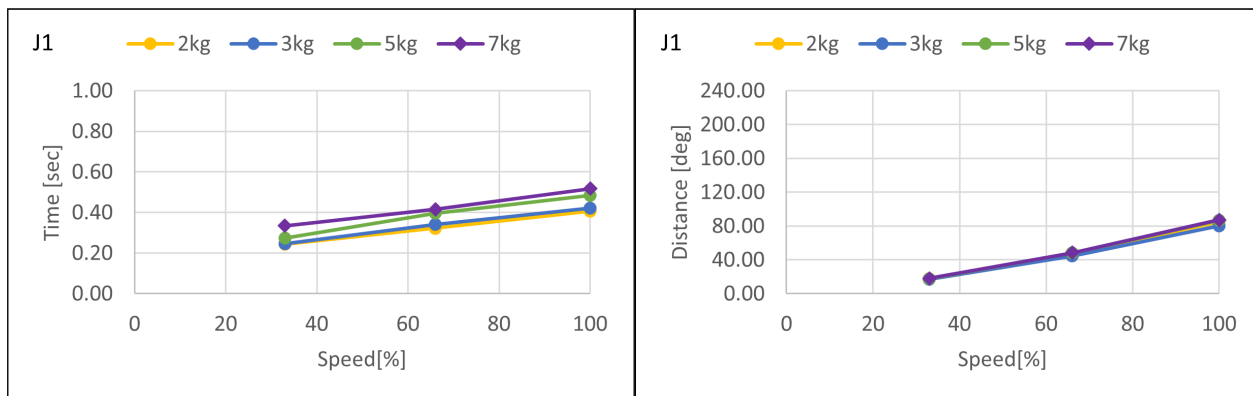

#### Boost mode

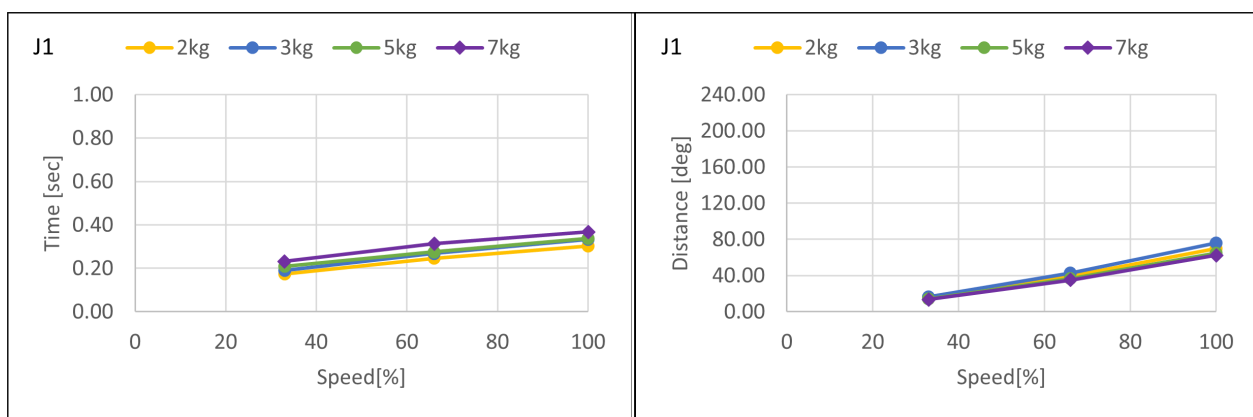

**CX7-A701\*\*\*: J1 (Wall mounting)**

Standard mode

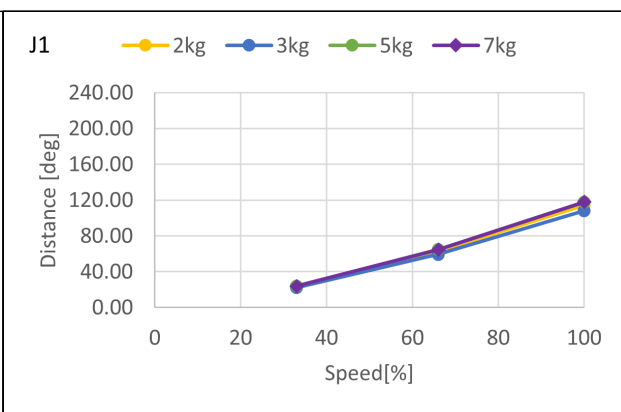
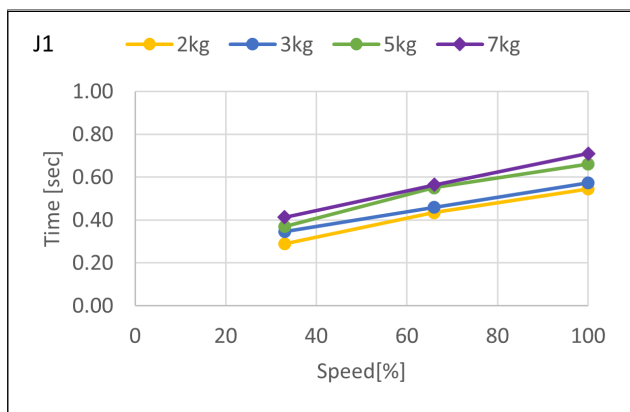

Boost mode

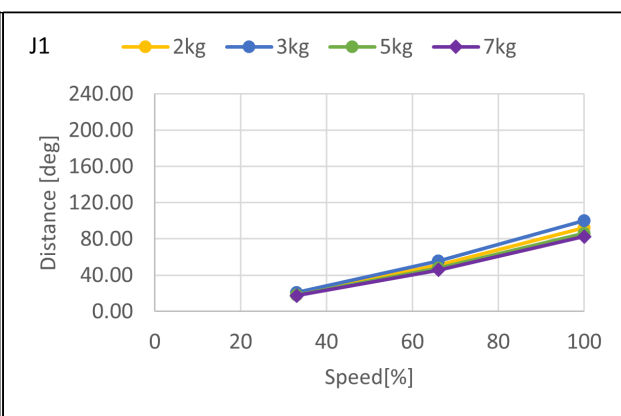
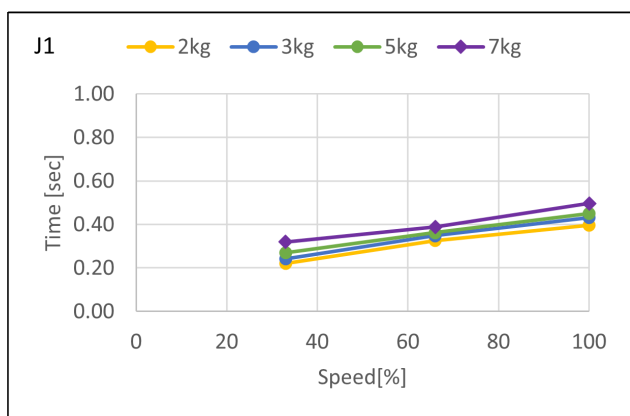

**CX7-A701\*\*\*: J2 (Table top mounting, Ceiling mounting, Wall mounting)**

Standard mode

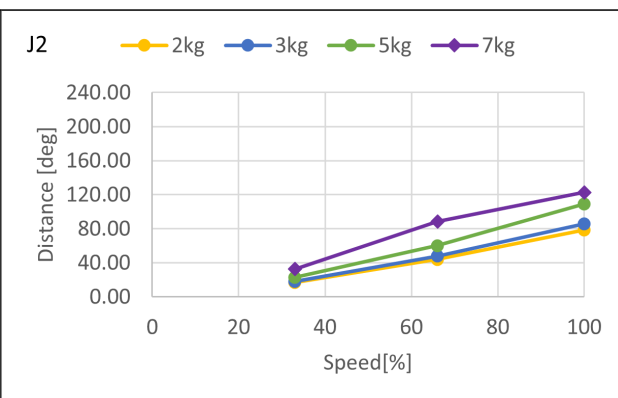
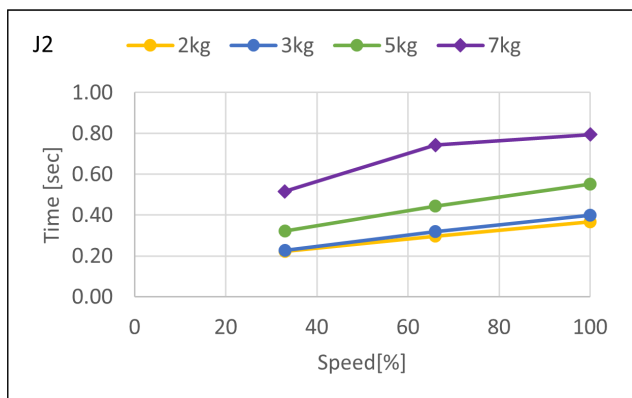

Boost mode

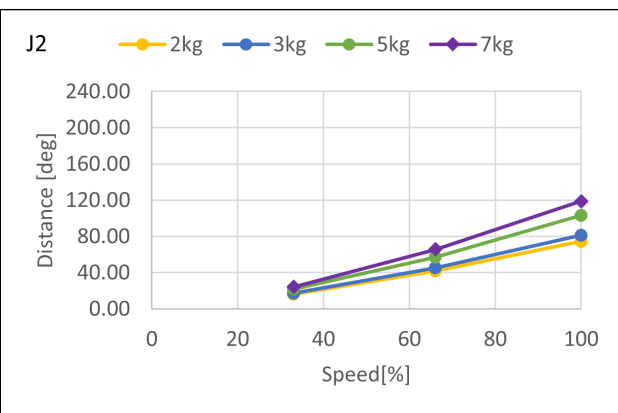
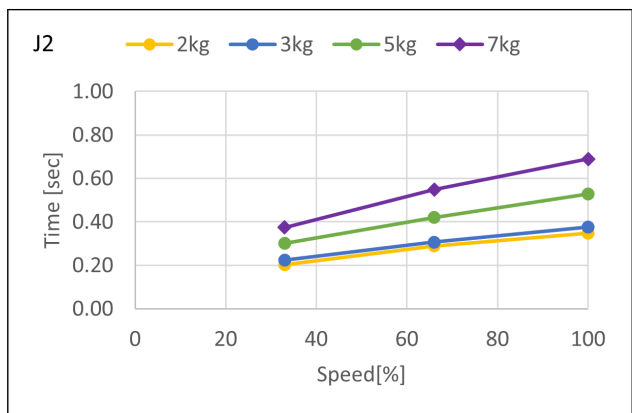

**CX7-A701\*\*\*: J3 (Table top mounting, Ceiling mounting, Wall mounting)**

Standard mode

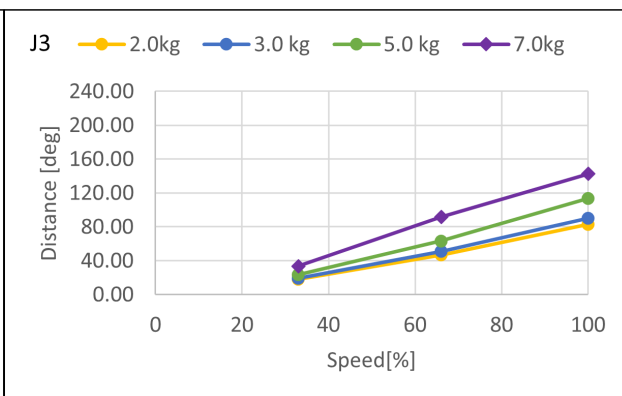
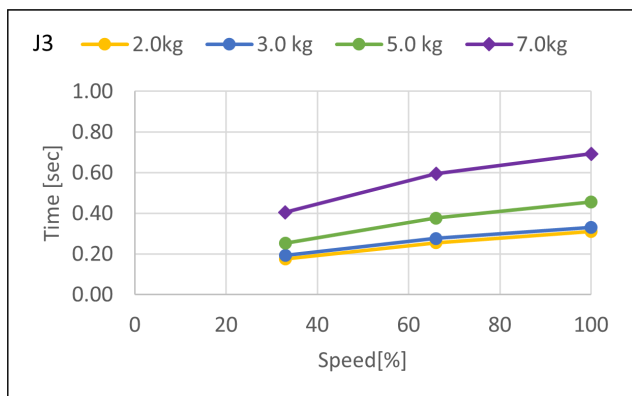

Boost mode

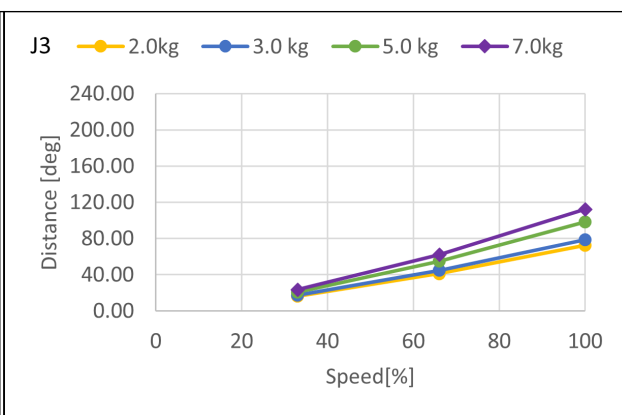
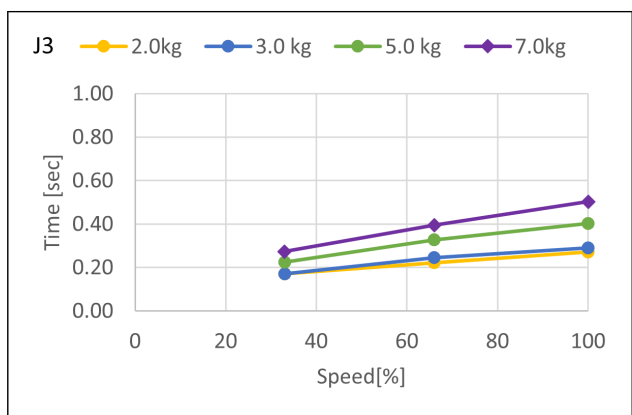

**CX7-A701\*\*\*: J4 (Table top mounting, Ceiling mounting, Wall mounting)**

Standard mode

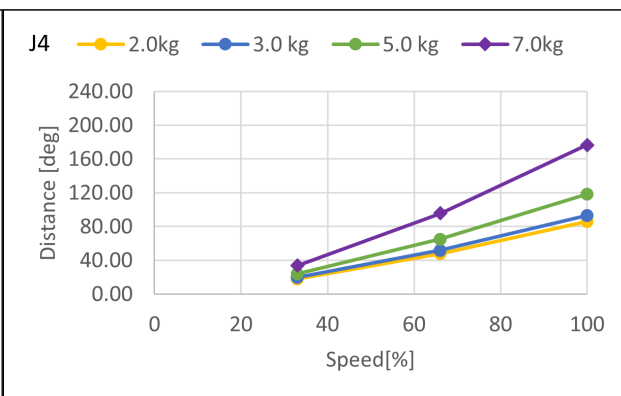
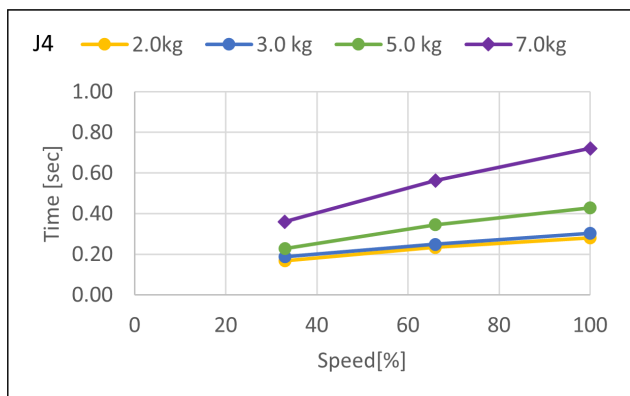

Boost mode

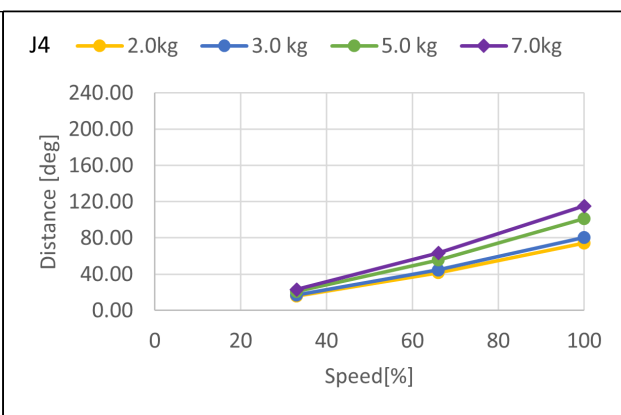
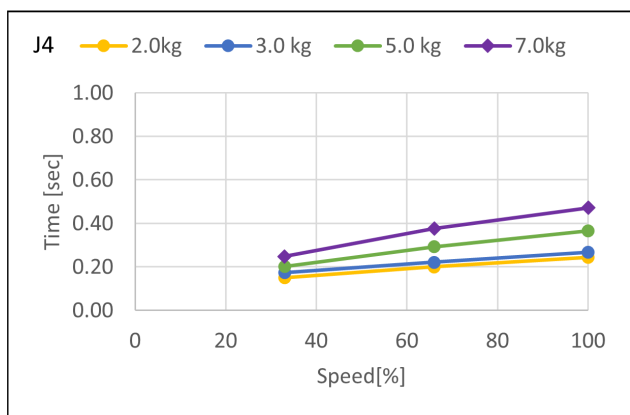

**CX7-A701\*\*\*: J5 (Table top mounting, Ceiling mounting, Wall mounting)**

Standard mode

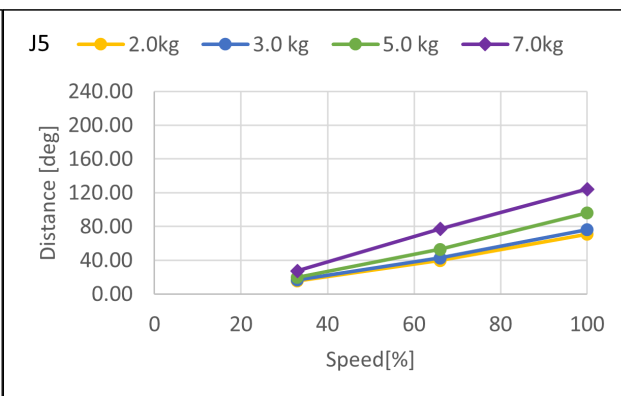
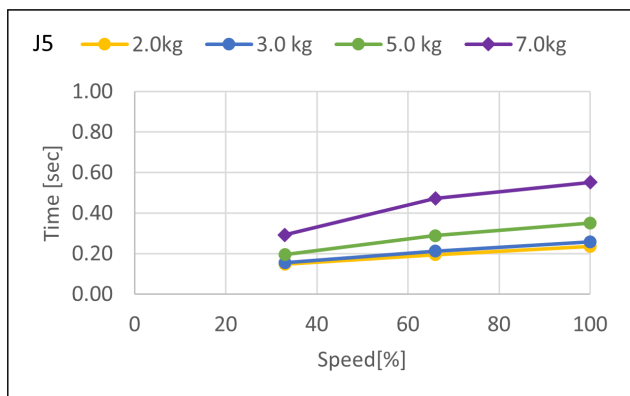

Boost mode

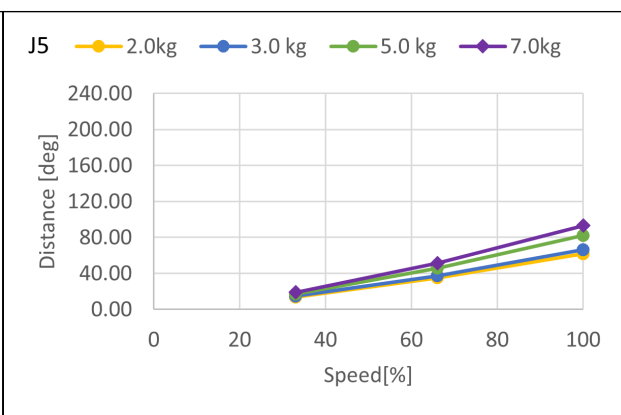
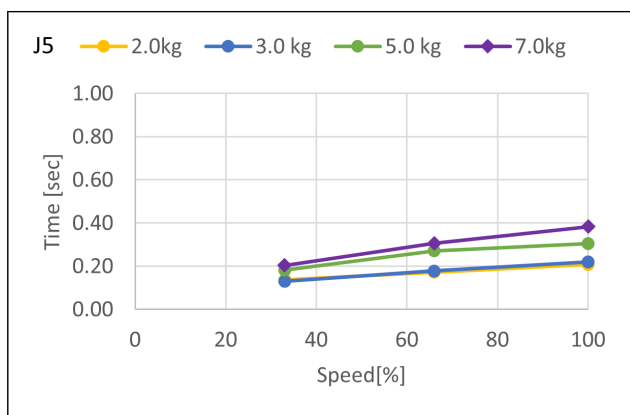

**CX7-A701\*\*\*: J6 (Table top mounting, Ceiling mounting, Wall mounting)**

Standard mode

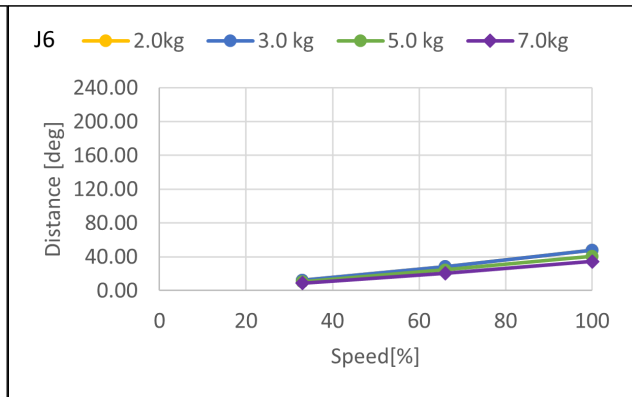
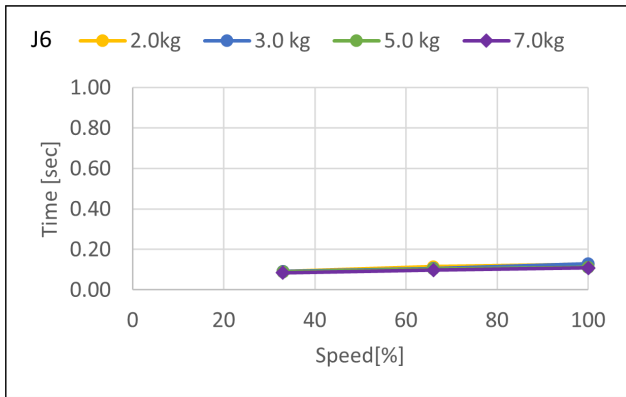

Boost mode

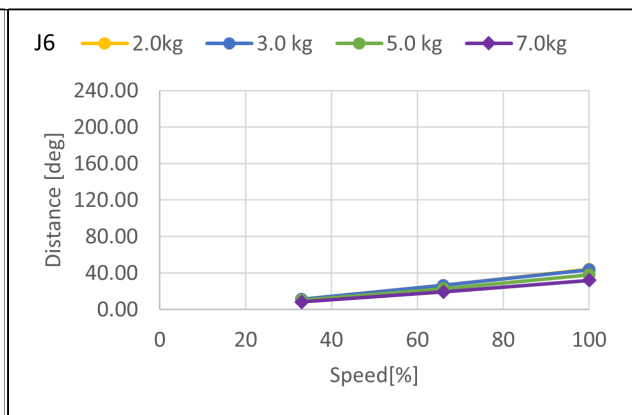
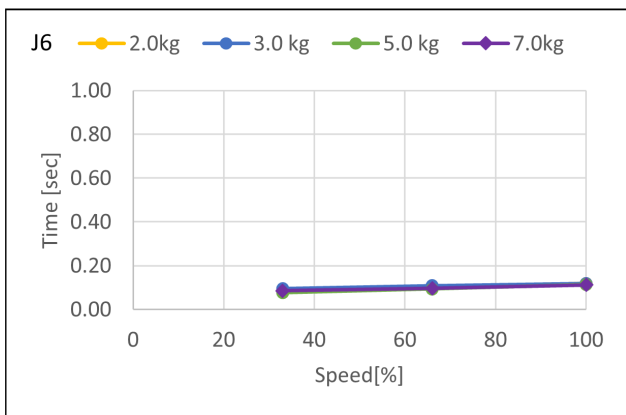

**CX7-A901\*\*\*: J1 (Table top mounting, Ceiling mounting)**

Standard mode

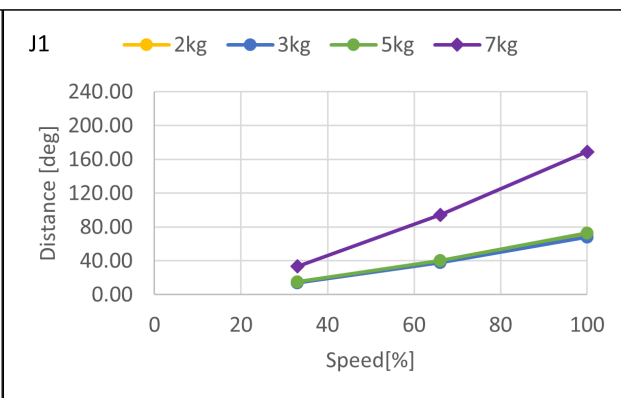
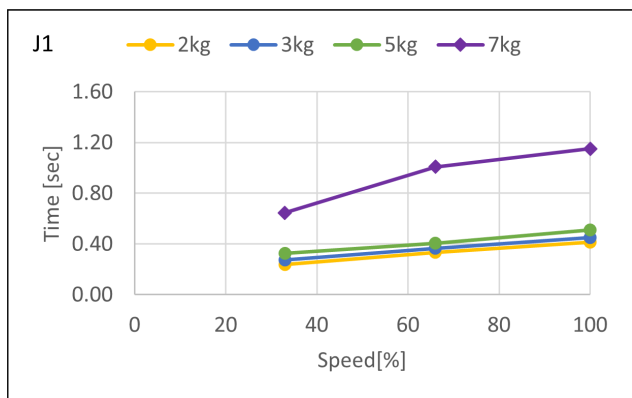

Boost mode

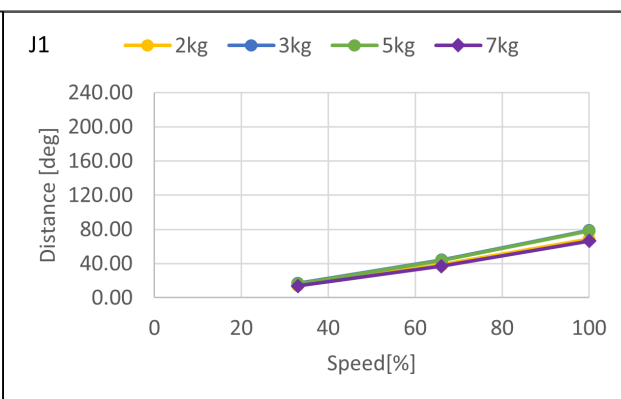
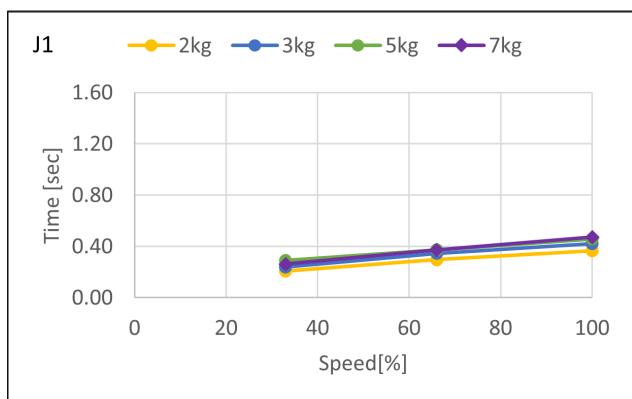

**CX7-A901\*\*\*: J1 (Wall mounting)**

Standard mode

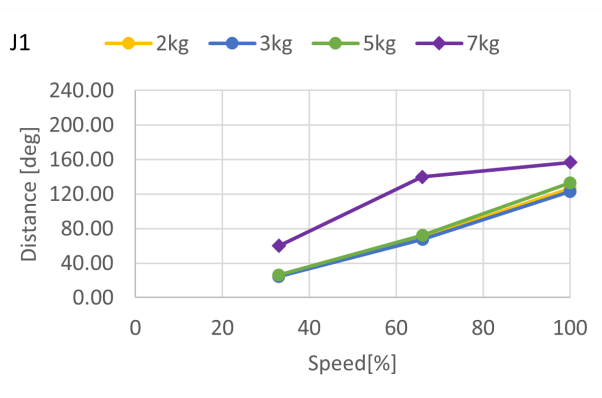
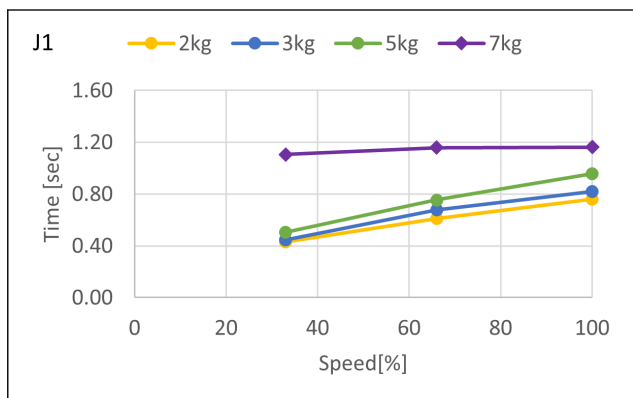

Boost mode

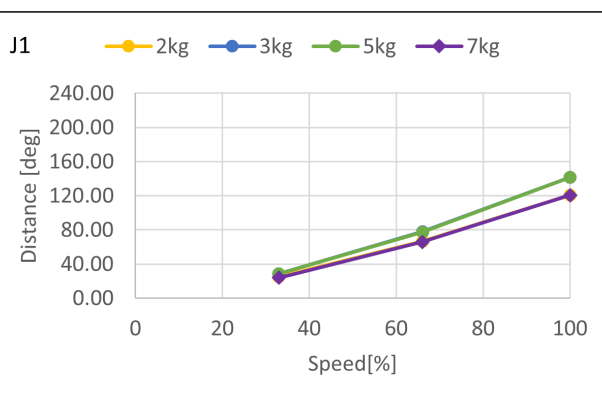
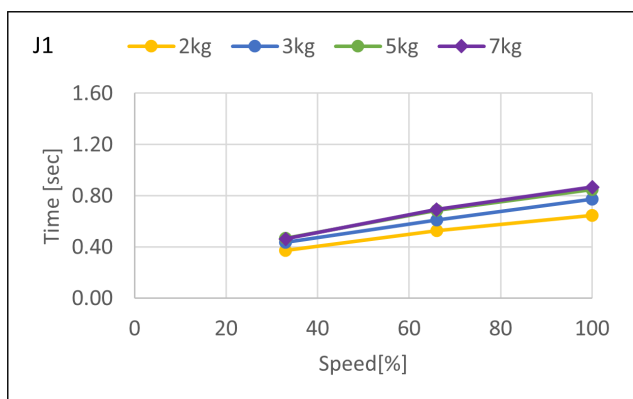

**CX7-A901\*\*\*: J2 (Table top mounting, Ceiling mounting, Wall mounting)**

Standard mode

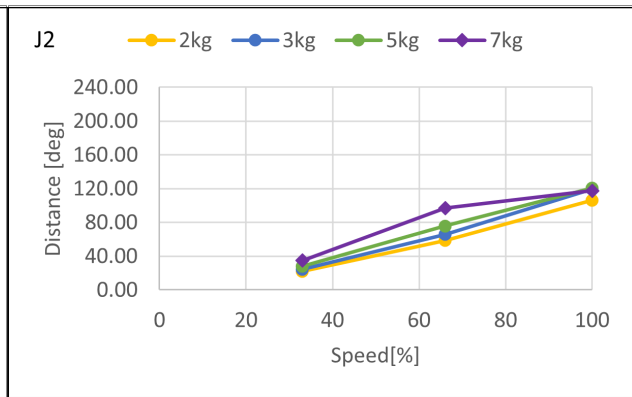
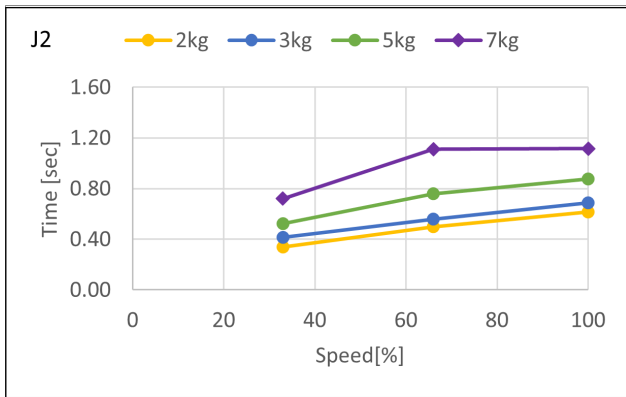

Boost mode

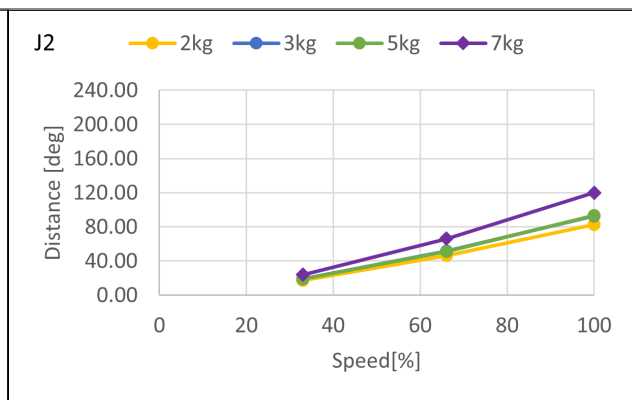
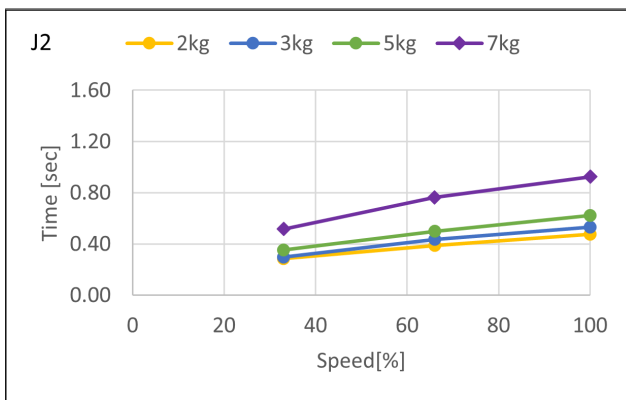

**CX7-A901\*\*\*: J3 (Table top mounting, Ceiling mounting, Wall mounting)**

Standard mode

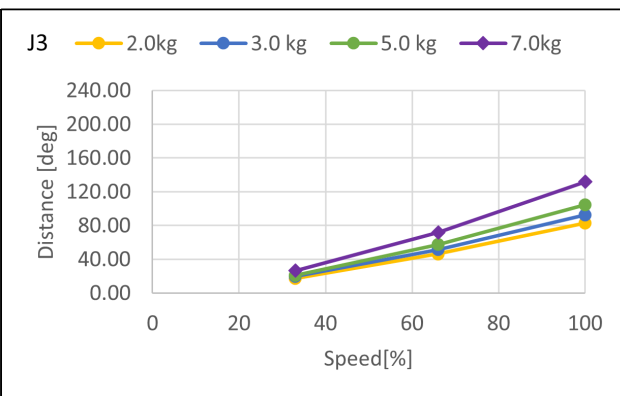
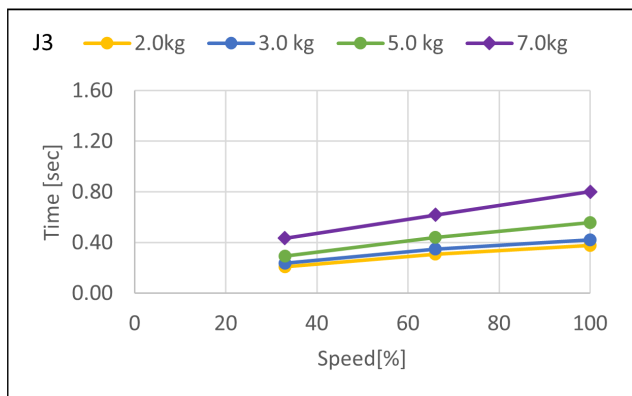

Boost mode

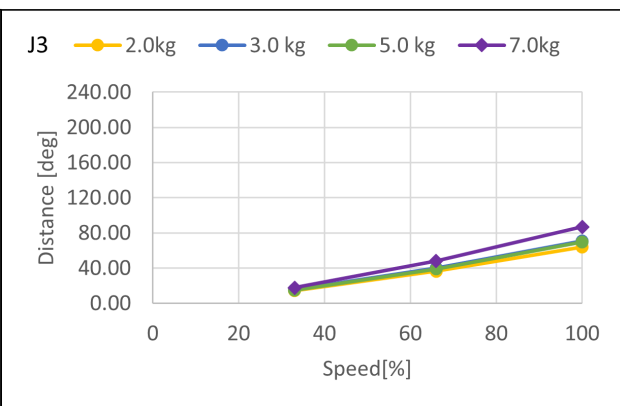
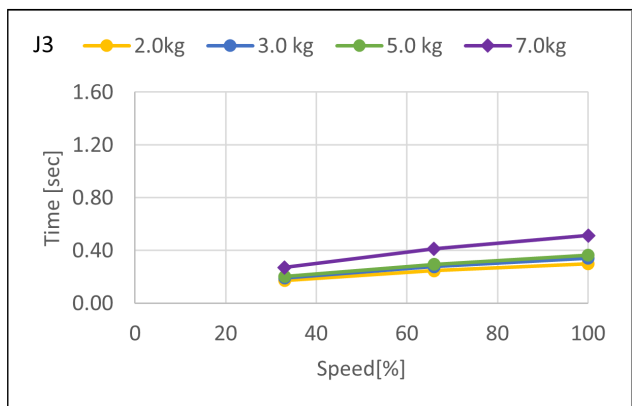

**CX7-A901\*\*\*: J4 (Table top mounting, Ceiling mounting, Wall mounting)**

Standard mode

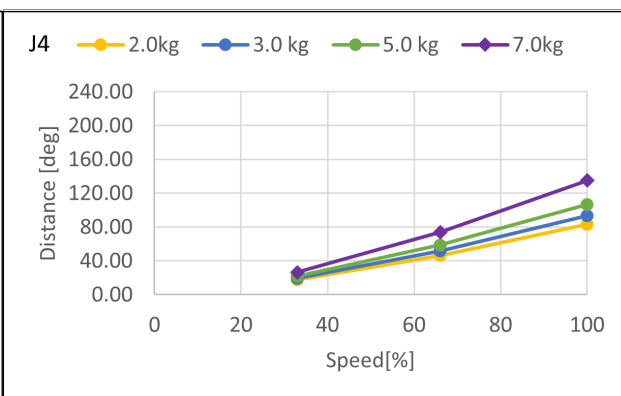
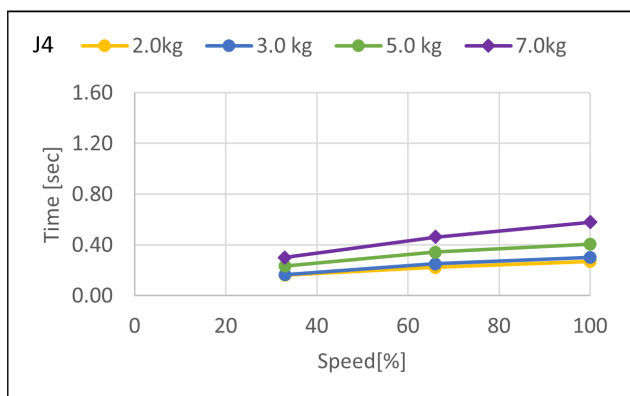

Boost mode

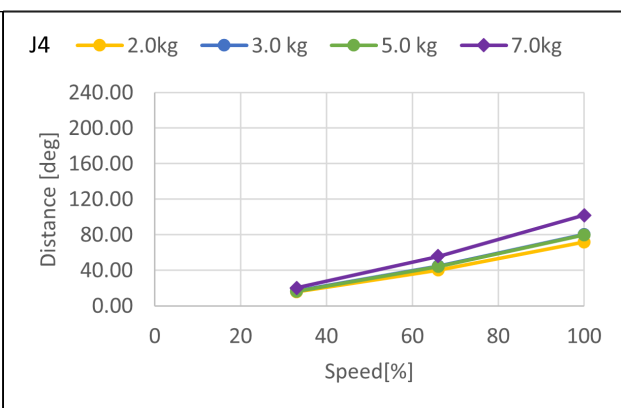
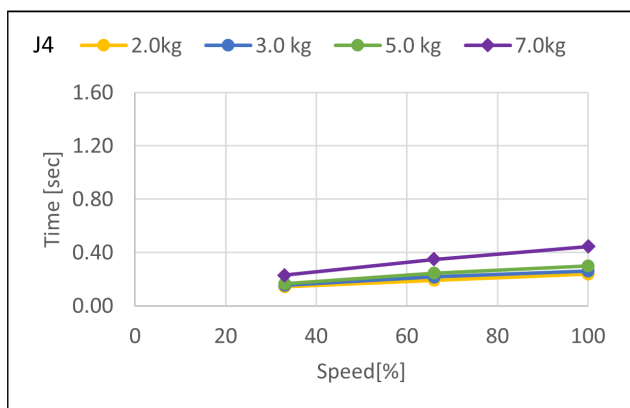

**CX7-A901\*\*\*: J5 (Table top mounting, Ceiling mounting, Wall mounting)**

Standard mode

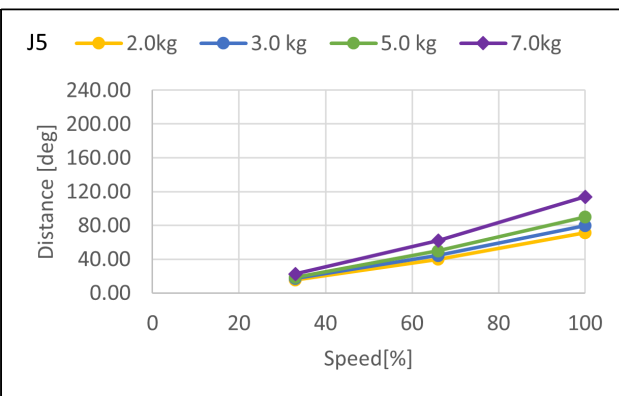
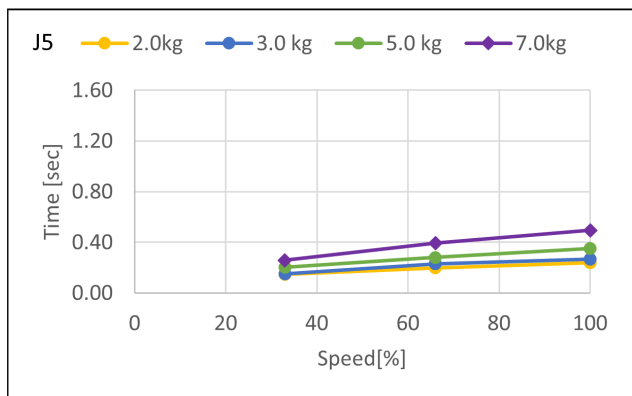

Boost mode

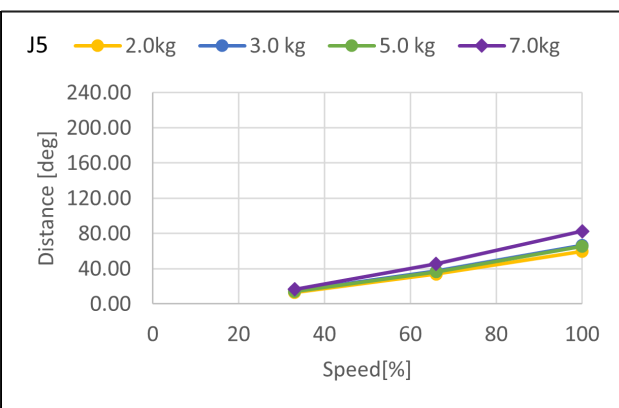
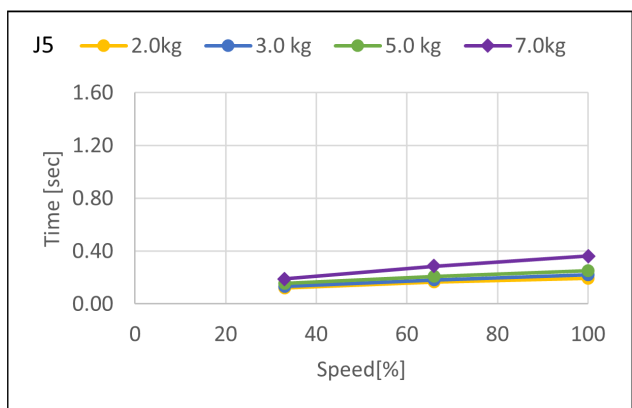

**CX7-A901\*\*\*: J6 (Table top mounting, Ceiling mounting, Wall mounting)**

Standard mode

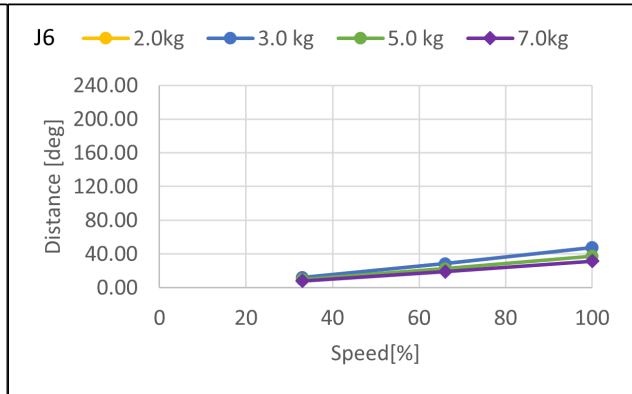
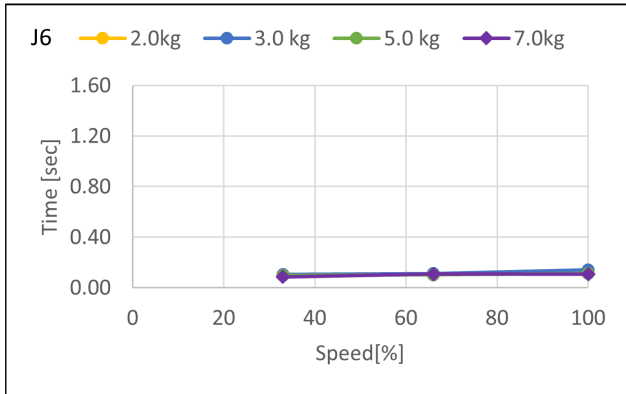

Boost mode

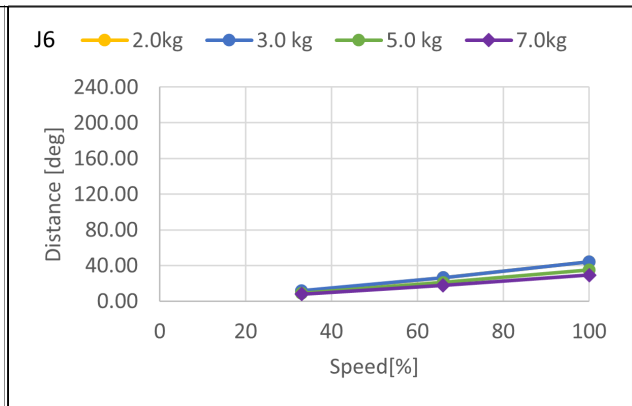
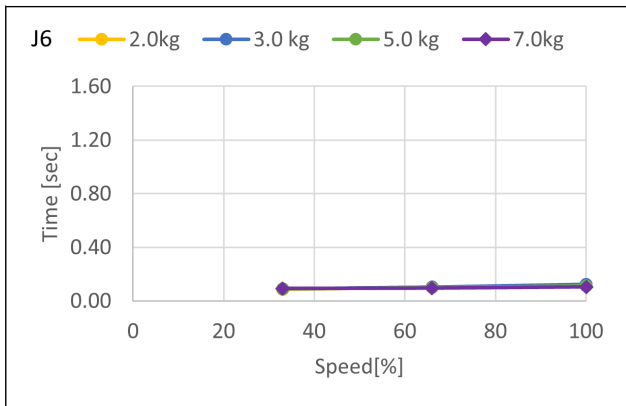

## 5.2.3 Supplementary Information regarding the Stopping Time and Stopping Distance at Emergency Stop

The stopping time and stopping distance described in Appendix B was measured by the motion determined by us based on the ISO 10218-1.

Therefore, it does not guarantee the maximum value of the stopping time and stopping distance in the customer's environment. The stopping time and stopping distance differs depending on the robot's model, motion, and input timing of the stop signal. Make sure to always measure the stopping time and stopping distance that matches the customer's environment.

### KEY POINTS

The following are included in the robot's motion and parameter.

- The motion's starting point, target point, and relay point
- Motion commands (Go, Move, Jump commands etc.)
- Weight and Inertia Settings
- Motion speed, acceleration, deceleration, and one where the motion timing changes

Also, refer to the following description.

CX4:

[WEIGHT and INERTIA Settings](#)

[Safety Information for Auto Acceleration](#)

CX7:

[WEIGHT and INERTIA Settings](#)

[Safety Information for Auto Acceleration](#)

### 5.2.3.1 How to check the stopping time and stopping distance in the customer's environment

Measure the stopping time and stopping distance of the actual motion with the following method.

1. Create a motion program in the customer's environment.
2. After the motion to check the stopping time and stopping distance starts, input the stop signal at your own timing.
3. Record the time and distance from when the stop signal was input until the robot stopped.
4. Check the maximum stopping time and stopping distance by repeating 1 through 3 mentioned above.
  - How to input the stop signal: Operate the stop switch manually or input the stop signal with the safety PLC.
  - How to measure the stopping position: Measure with a tape measure. The angle could also be measured with the Where or RealPos command.
  - How to measure the stopping time: Measure with a stop watch. The Tmr function can also be used to measure the stopping time.

### CAUTION

The stopping time and stopping distance changes depending on the timing the stop signal is input.

In order to prevent collision with people or objects, perform a risk assessment based on the maximum stopping time and stopping distance and perform an equipment design.

Therefore, make sure to measure the maximum value by changing the timing of the stop signal input during the actual motion and measure repeatedly.

To shorten the stopping time and stopping distance, use the Safety Limited Speed (SLS) and limit the maximum speed.  
For details on the safety limited speed, refer to the following manual.

“Safety Function Manual“

### 5.2.3.2 Commands that can be useful when measuring stopping time and stopping distance

Commands	Functions
Where	Returns the data of the robot's current position
RealPos	Returns the current position of the specified robot Unlike the motion target position of the CurPos, this obtains the position of the actual robot from the encoder in real time.
PAgl	Returns by calculating the Joint position from the specified coordinate value. P1 = RealPos 'Obtain the current position Joint1 = PAgl (P1, 1) 'Request the J1 angle from the current position
SF_RealSpeedS	Display the current speed from the limited speed position in mm/s.
Tmr	The Tmr function returns the elapsed time from when the timer starts in seconds.
Xqt	Runs the program specified with the function name and complete the task. The function used to measure the stopping time and stopping distance should be used to run tasks that were launched by attaching the NoEmgAbort options. You can run a task that does not stop with the emergency stop and safeguard open.

For more information, refer to the following manual.

"Epson RC+ SPEL+ Language Reference"

## 5.3 Appendix C: Stopping Time and Stopping Distance When Safeguard is Open

The stopping time and stopping distance when the safeguard is opened are shown in the graphs for each model.

The stopping time is the length of time corresponding to the "Stopping time" in the figure below. Be sure to confirm that a safe environment is provided where the robot will be installed and operated.

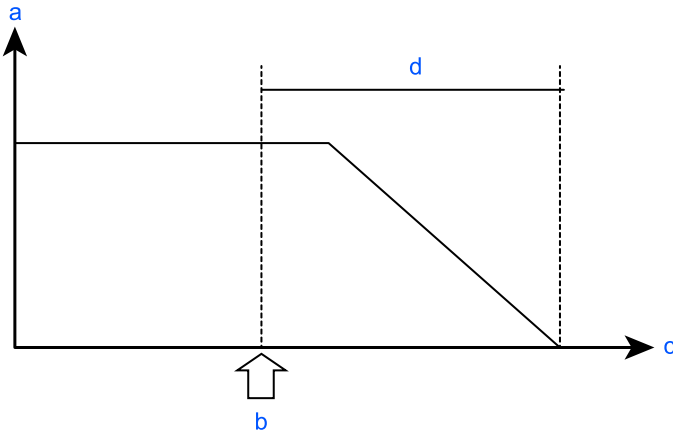

Symbol	Description
a	Motor speed
b	Safeguard open
c	Time
d	Stopping time

Conditions:

The stopping time and stopping distance depend on the parameters (setting values) that were set for the robot. These graphs show the times and distances for the following parameters.

These conditions are based on the ISO 10218-1:2011 Annex B.

- Accel: 100, 100
- Speed: 100 %, 66 %, 33 % Settings
- Weight: 100 %, 66 %, 33 % of the maximum payload, rated payload\*1
- Arm elongation rate: 100 %, 66 %, 33 % \*2
- Other settings: Default
- Motion: Singular axis motion of a Go command \*3
- Input timing of the Stop signal: input with maximum speed. In this motion, it is the center of the motion range.

\*1: Weight: The 5 kg condition for the CX4-A601 requires operation with the flange surface within a range of  $\pm 30^\circ$  in the direction of gravity.

\*2: Arm elongation rate: The arm elongation rate L is as shown below: The graphs indicate the results where the stopping time and the stopping distance in the longest among the arm elongation rates.

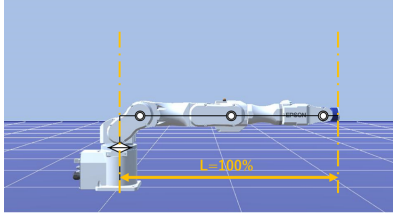
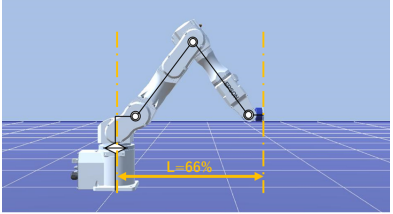
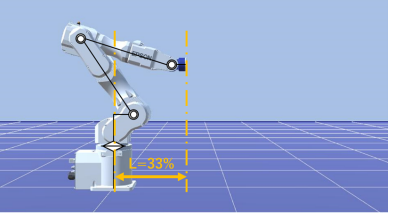
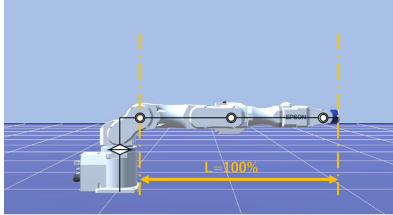
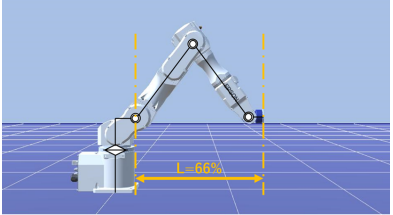
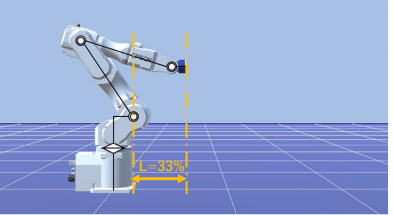
Axis	L=100%	L=66%	L=33%
J1			
J2			

\*3: Operation: The 5 kg condition for the CX4-A601\*\*\* requires operation with the flange surface within a range of  $\pm 30^\circ$  in the direction of gravity.

Explanation of legend:

The graphs are displayed for each Weight setting value (at 100%, approx. 66%, and approx. 33% of the maximum payload, and at the rated payload).

- Horizontal axis: Arm speed (Speed setting)
- Vertical axis: Stopping time and stopping distance at each arm speed
- Time (sec): Stopping time (sec)
- Distance (deg): stopping distance (degree)

When single failures are taken into account, the following adjustments are used.

- Stopping distance and angle: Each axis reaches the mechanical stop
- Stopping time: Add 500 ms

### 5.3.1 CX4-A Stopping Time and Stopping Distance When Safeguard is Open

#### CX4-A601\*\*\*: J1 (Table top mounting, Ceiling mounting)

Standard mode

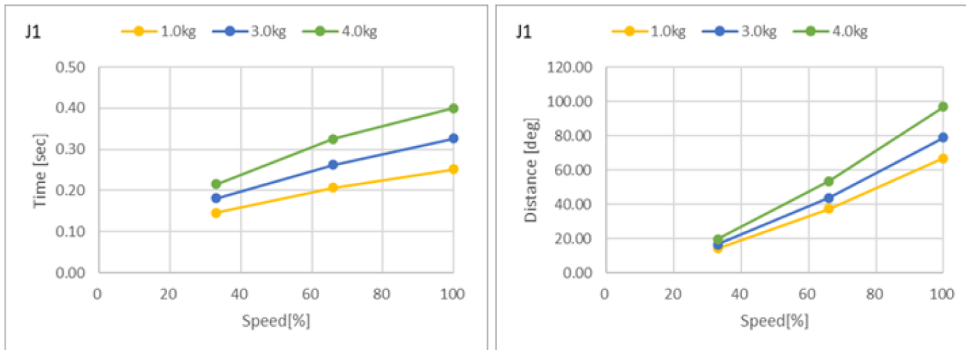

Boost mode

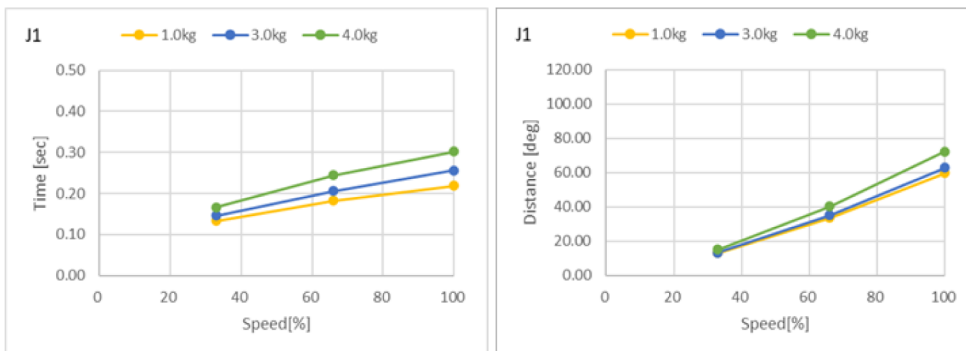

**CX4-A601\*\*\*: J1 (Wall mounting)**

Standard mode

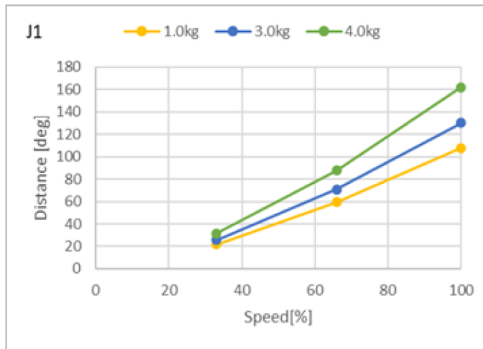
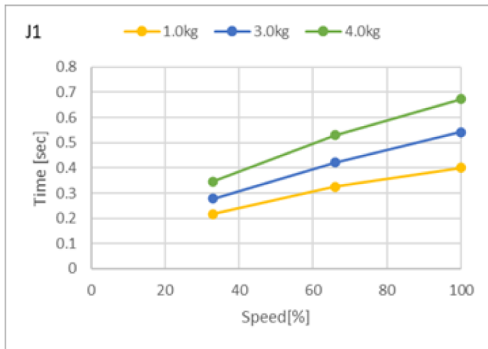

Boost mode

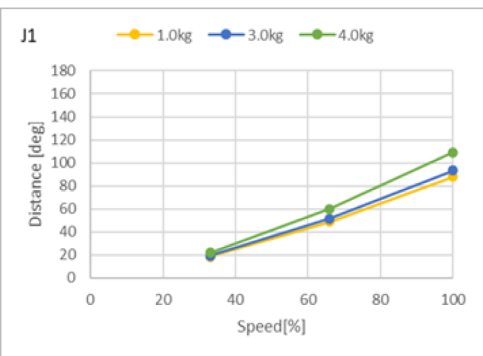
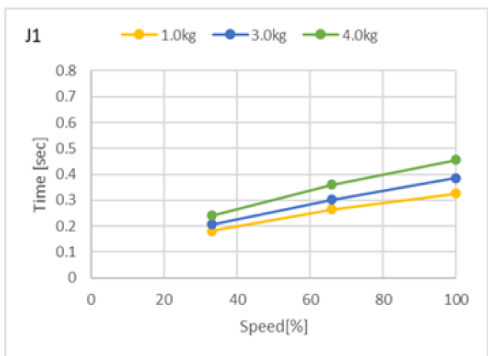

**CX4-A601\*\*\*: J2 (Table top mounting, Ceiling mounting, Wall mounting)**

Standard mode

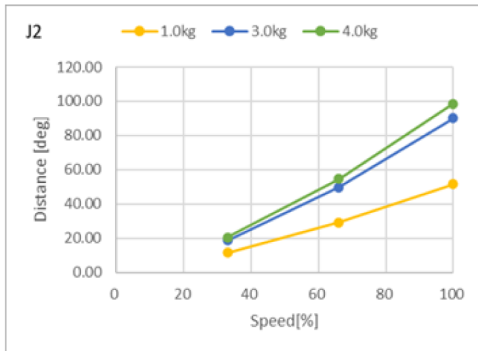
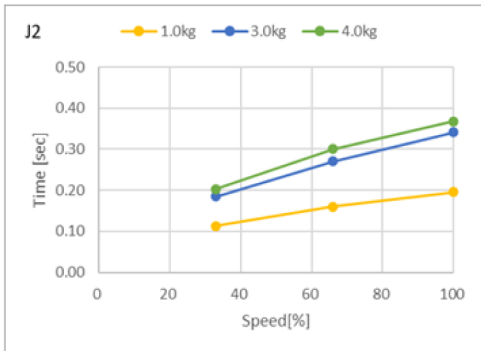

Boost mode

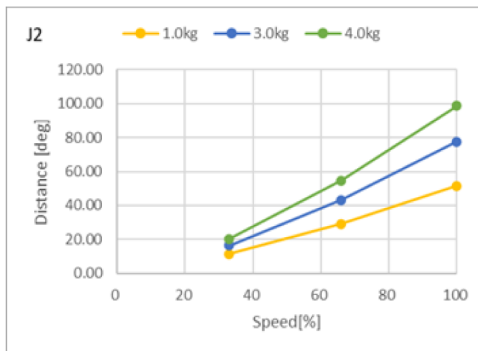
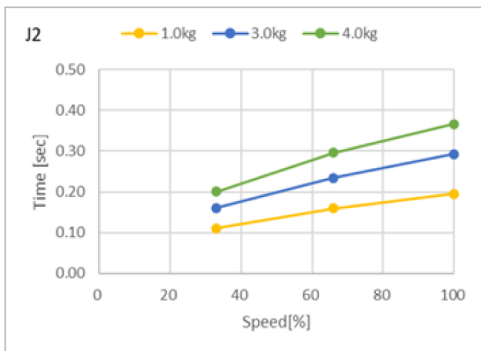

**CX4-A601\*\*\*: J3 (Table top mounting, Ceiling mounting, Wall mounting)**

Standard mode

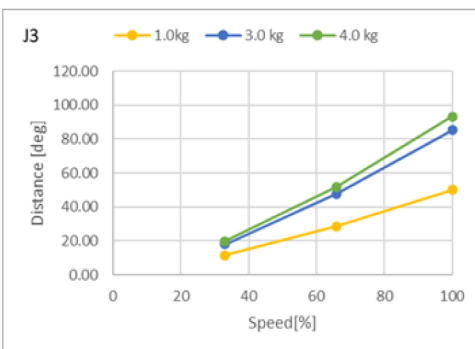
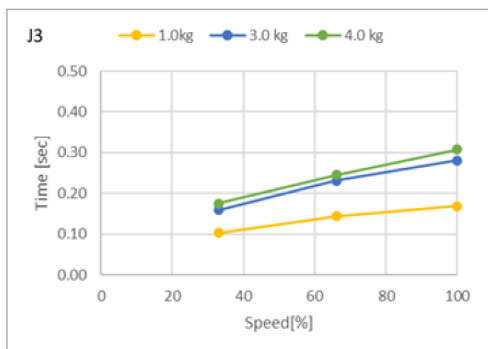

Boost mode

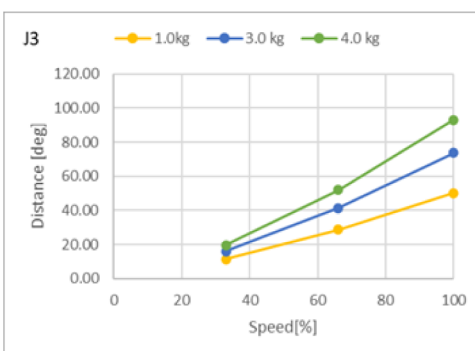
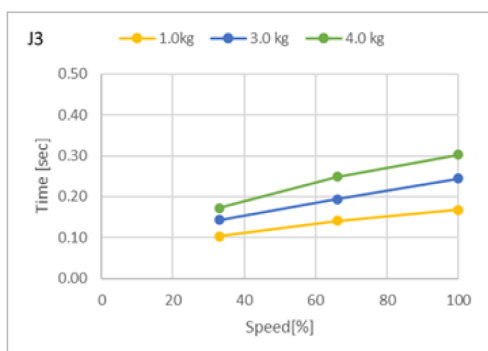

**CX4-A601\*\*\*: J4 (Table top mounting, Ceiling mounting, Wall mounting)**

Standard mode

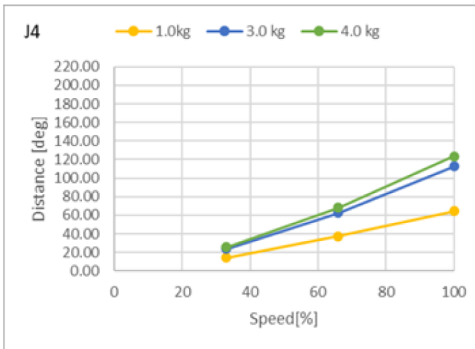
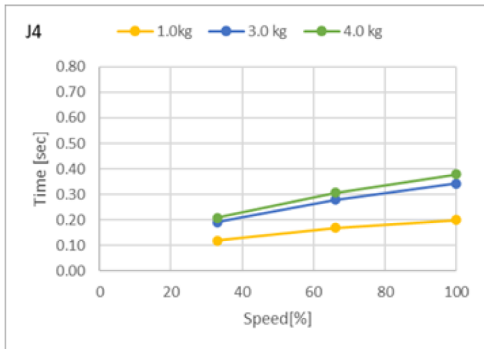

Boost mode

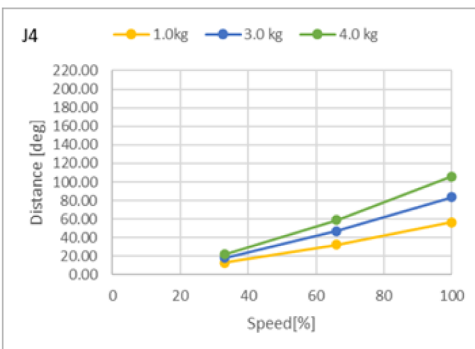
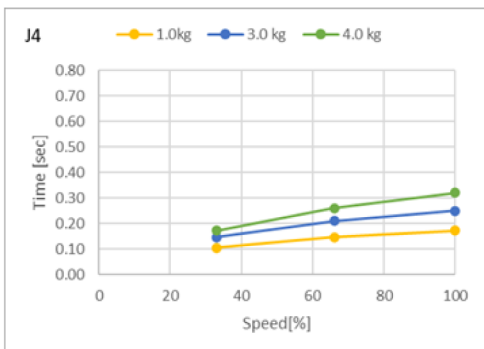

**CX4-A601\*\*\*: J5 (Table top mounting, Ceiling mounting, Wall mounting)**

Standard mode

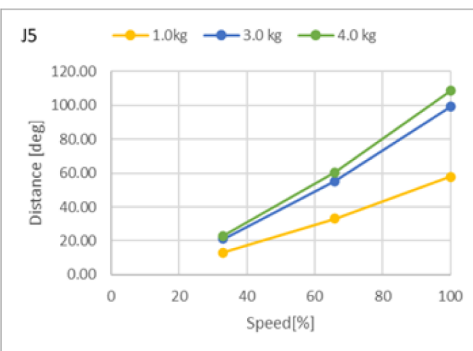
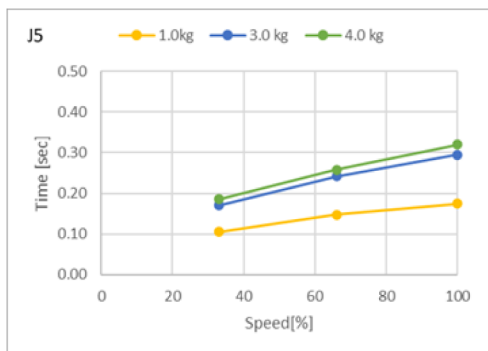

Boost mode

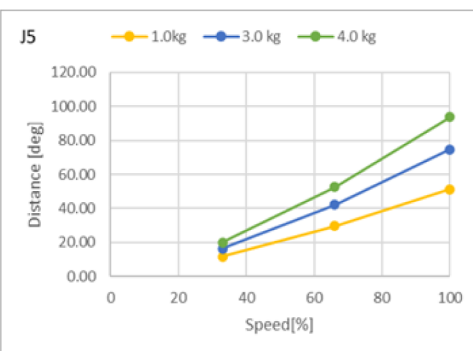
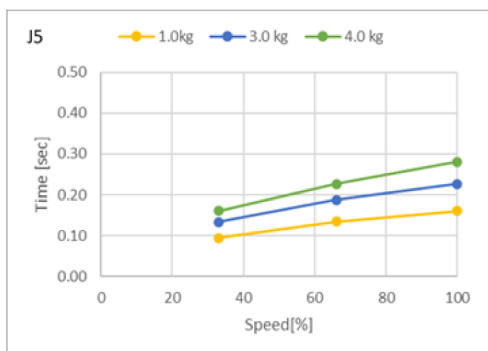

**CX4-A601\*\*\*: J6 (Table top mounting, Ceiling mounting, Wall mounting)**

Standard mode

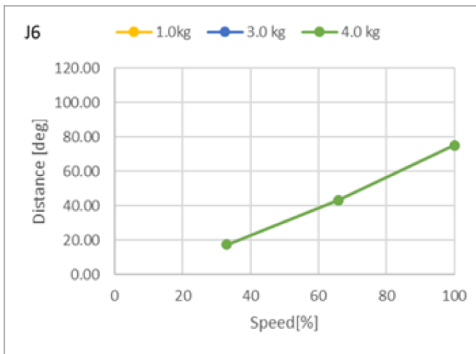
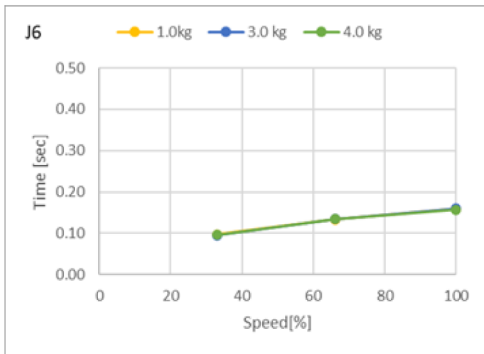

Boost mode

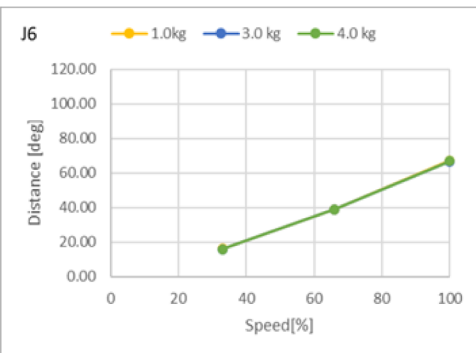
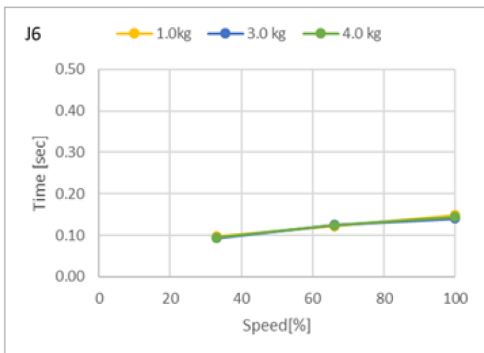

### CX4-A601\*\*\*: J1 (Table top mounting, Ceiling mounting)\_When grasping 5 kg

Standard mode

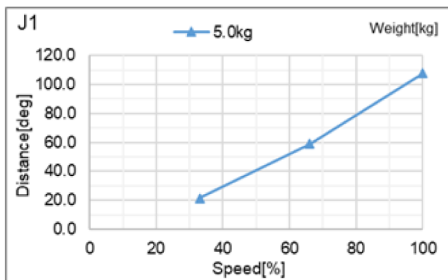
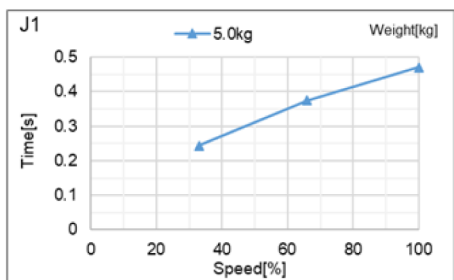

Boost mode

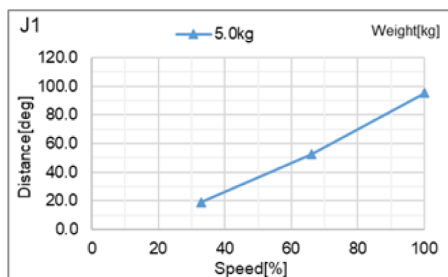
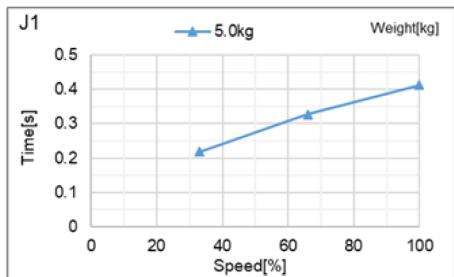

### CX4-A601\*\*\*: J1 (Wall mounting)\_When grasping 5 kg

Standard mode

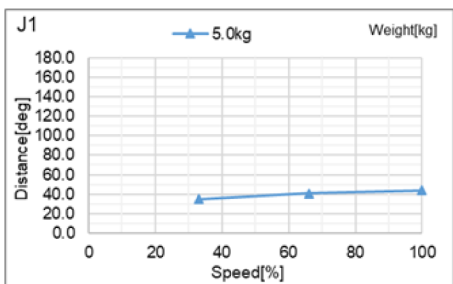
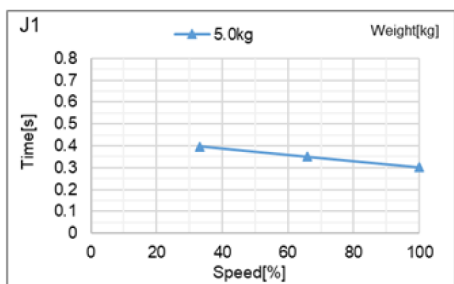

Boost mode

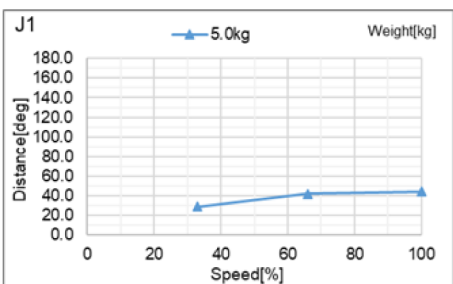
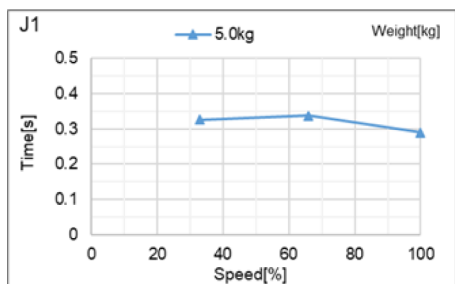

**CX4-A601\*\*\*: J2 (Table top mounting, Ceiling mounting)\_When grasping 5 kg**

Standard mode

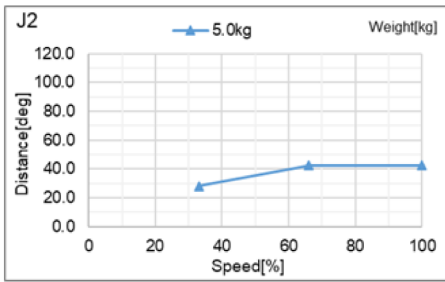
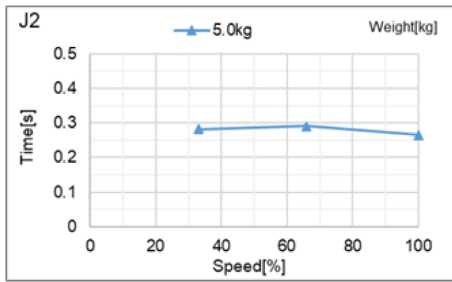

Boost mode

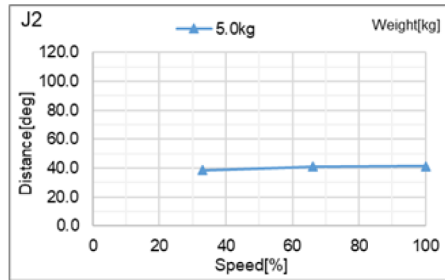
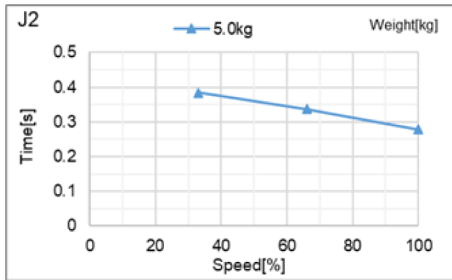

**CX4-A601\*\*\*: J2 (Wall mounting)\_When grasping 5 kg**

Standard mode

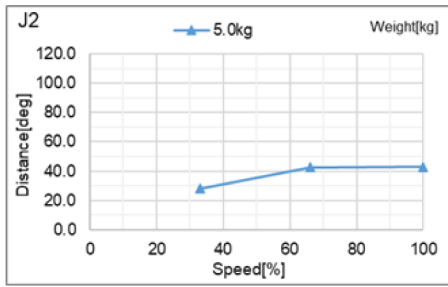
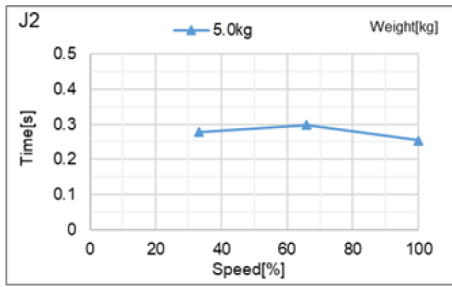

Boost mode

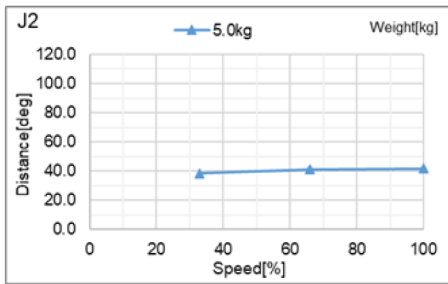
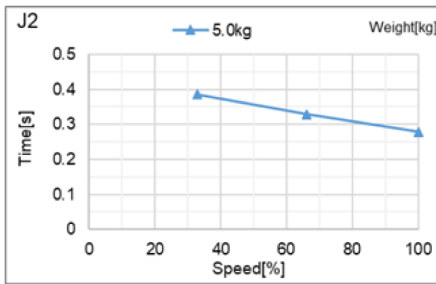

**CX4-A601\*\*\*: J3 (Table top mounting, Ceiling mounting)\_When grasping 5 kg**

Standard mode

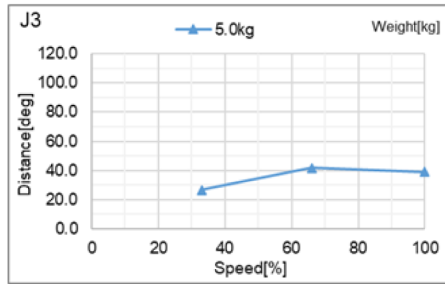
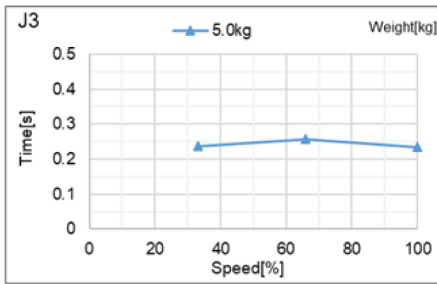

Boost mode

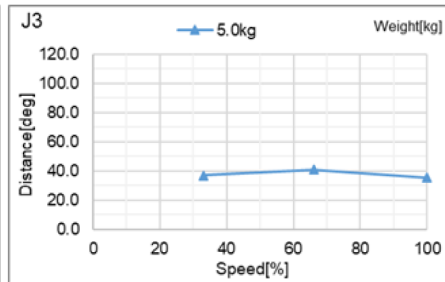
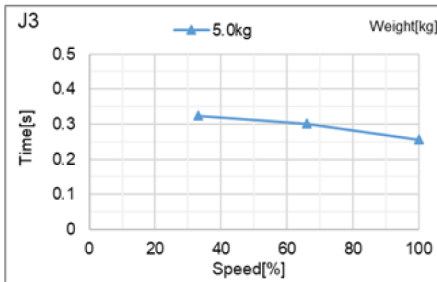

**CX4-A601\*\*\*: J3 (Wall mounting)\_When grasping 5 kg**

Standard mode

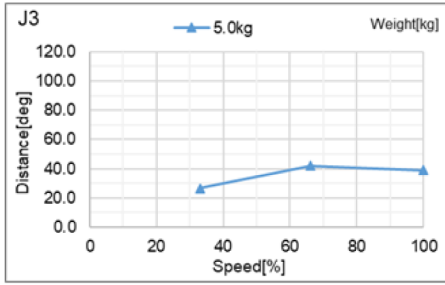
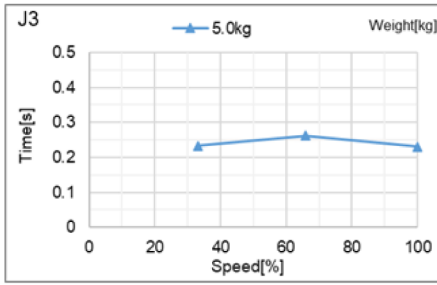

Boost mode

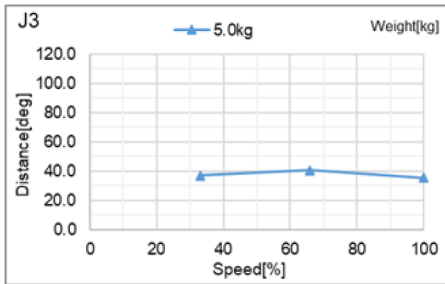
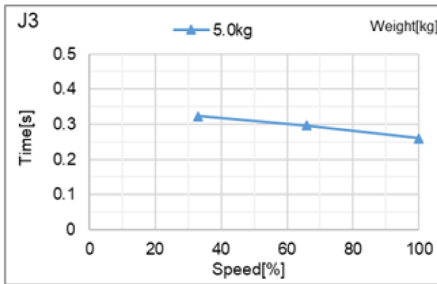

**CX4-A601\*\*\*: J4 (Table top mounting, Ceiling mounting)\_When grasping 5 kg**

Standard mode

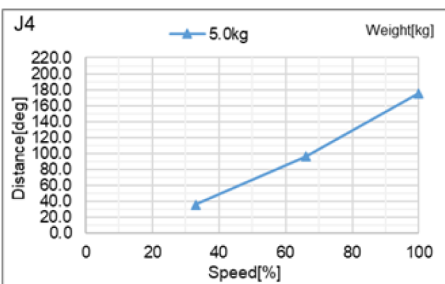
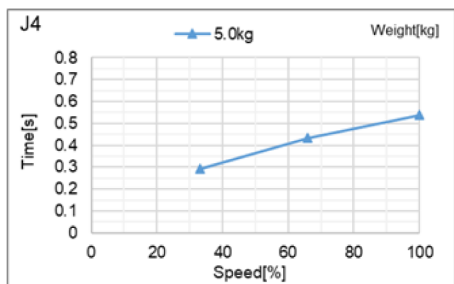

Boost mode

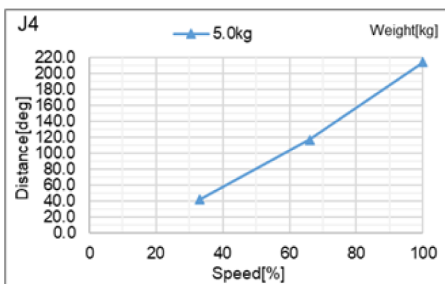
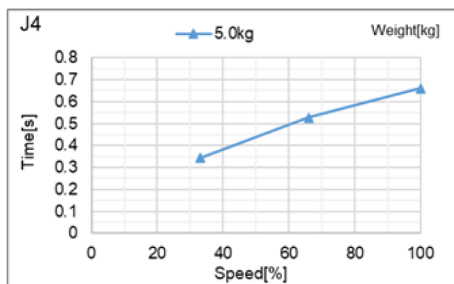

**CX4-A601\*\*\*: J4 (Wall mounting)\_When grasping 5 kg**

Standard mode

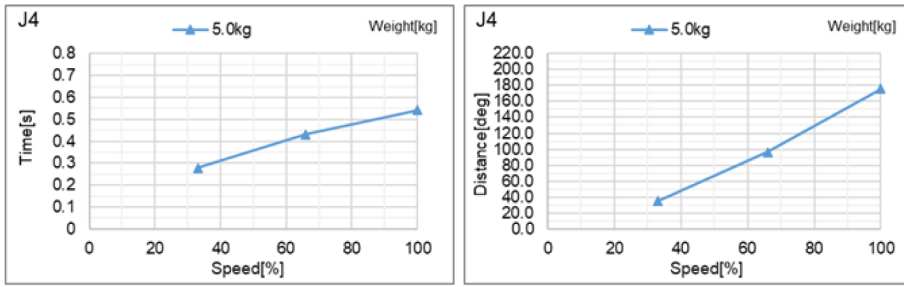

Boost mode

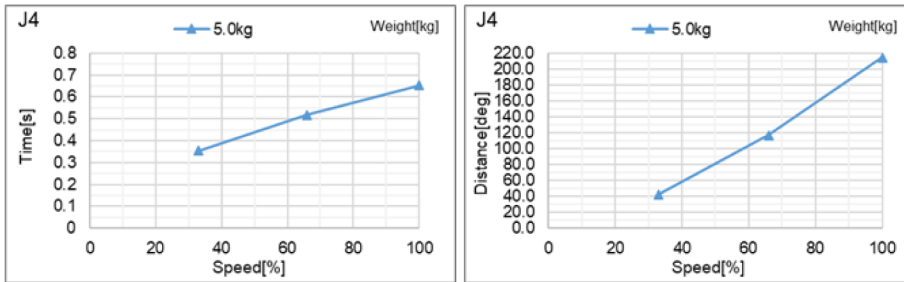

**CX4-A601\*\*\*: J5 (Table top mounting, Ceiling mounting)\_When grasping 5 kg**

Standard mode

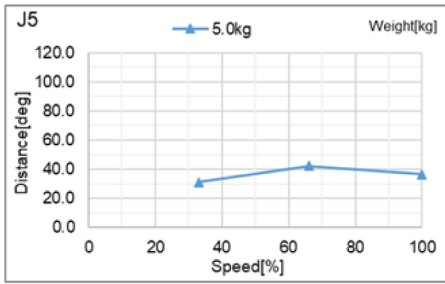
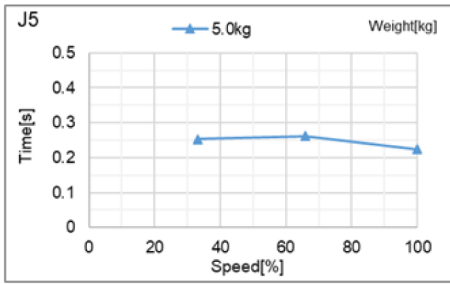

Boost mode

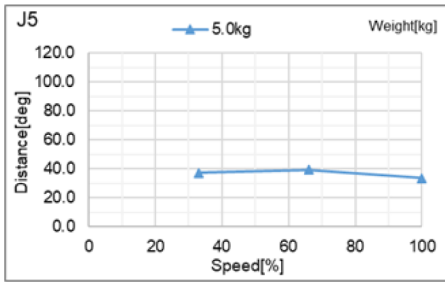
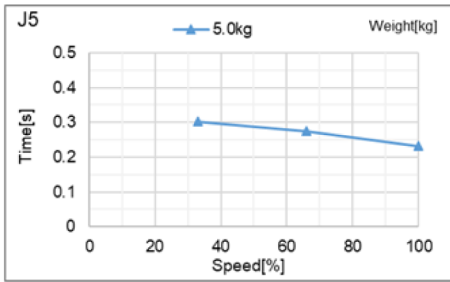

**CCX4-A601\*\*\*: J5 (Wall mounting)\_When grasping 5 kg**

Standard mode

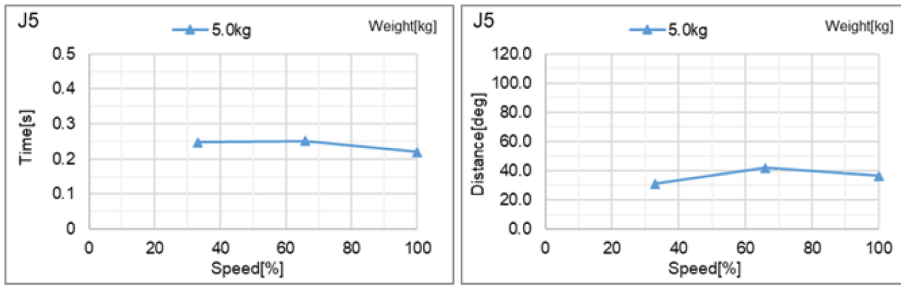

Boost mode

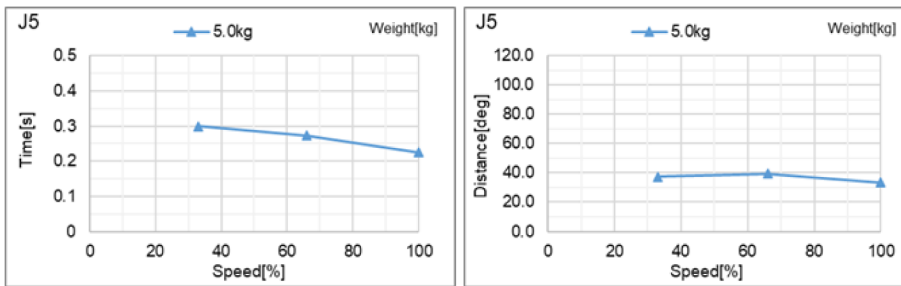

### CX4-A601\*\*\*: J6 (Table top mounting, Ceiling mounting)\_When grasping 5 kg

Standard mode

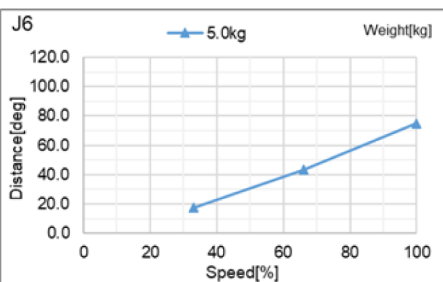
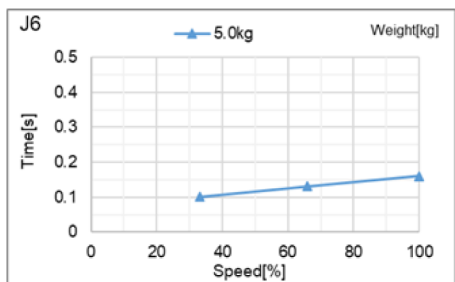

Boost mode

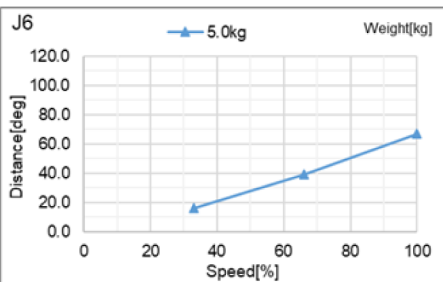
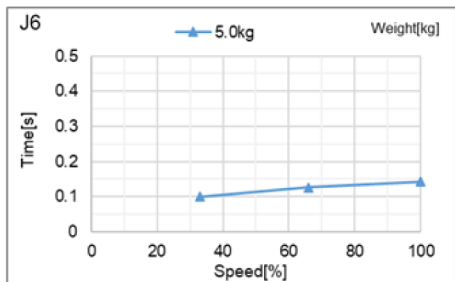

### CX4-A601\*\*\*: J6 (Wall mounting)\_When grasping 5 kg

Standard mode

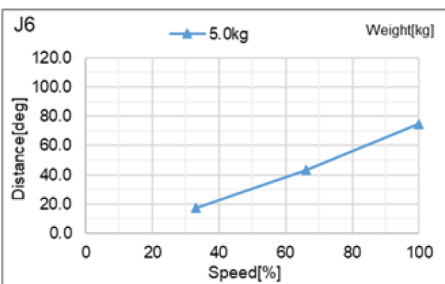
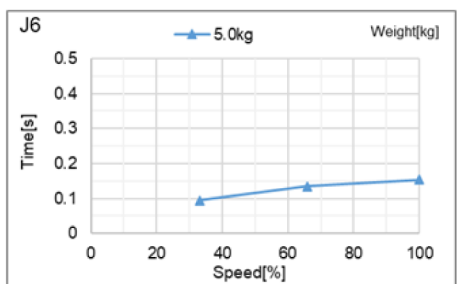

Boost mode

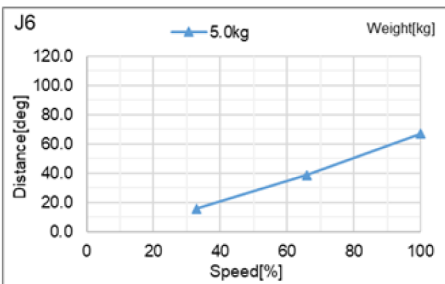
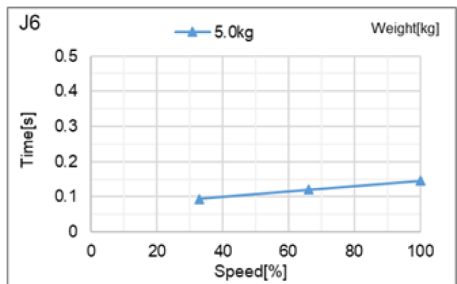

### 5.3.2 CX7-A Stopping Time and Stopping Distance When Safeguard is Open

#### CX7-A701\*\*\*: J1 (Table top mounting, Ceiling mounting)

##### Standard mode

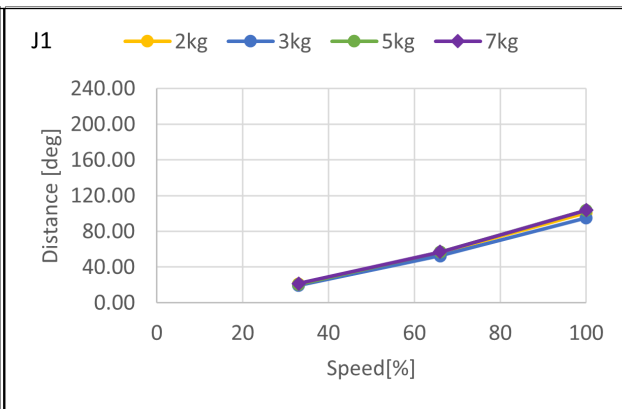
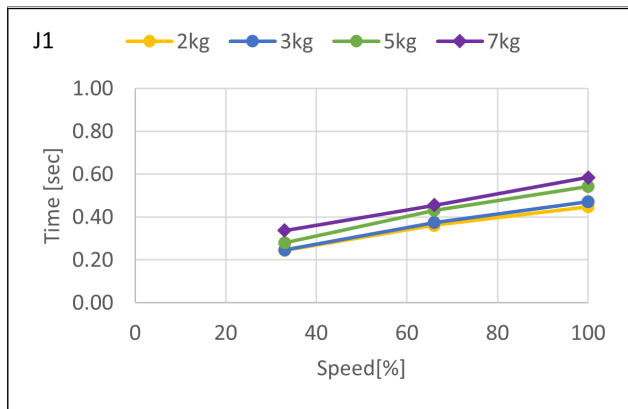

##### Boost mode

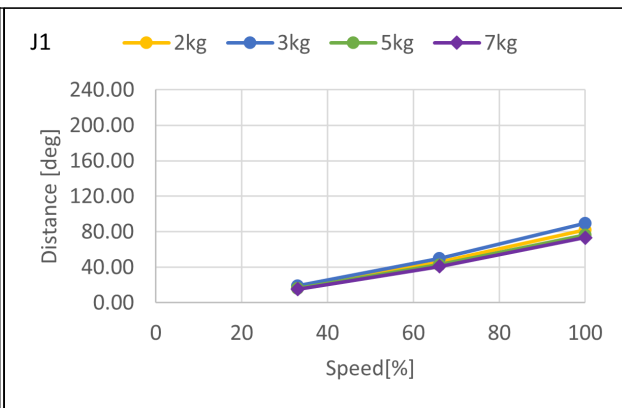
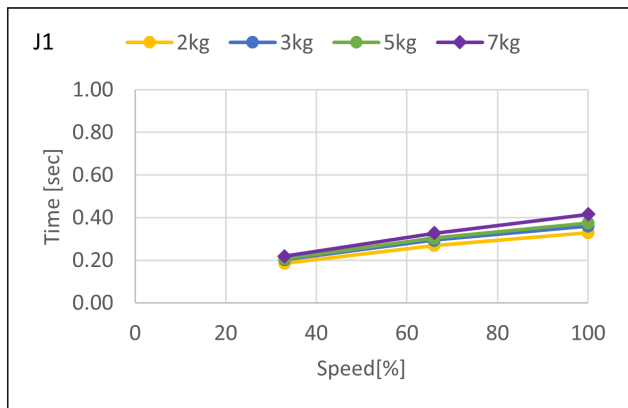

**CX7-A701\*\*\*: J1 (Wall mounting)**

Standard mode

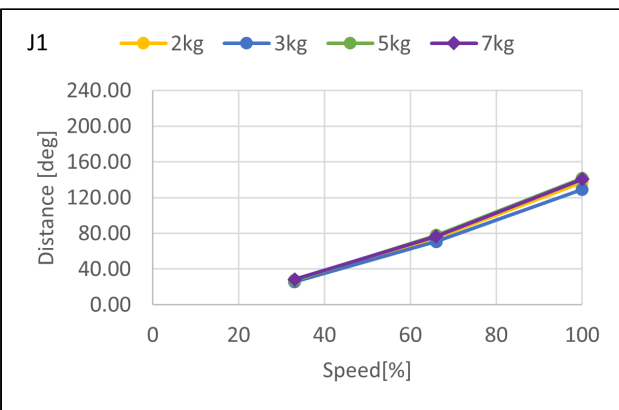
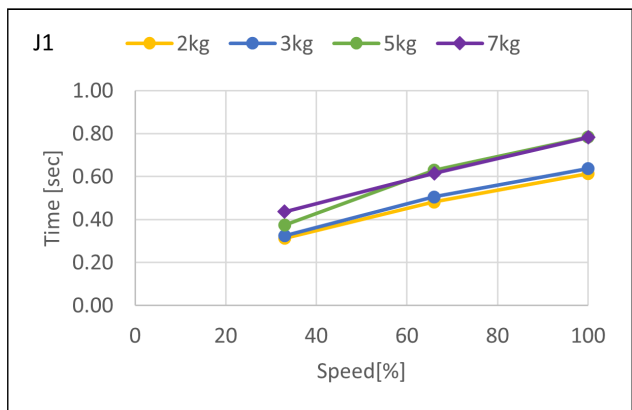

Boost mode

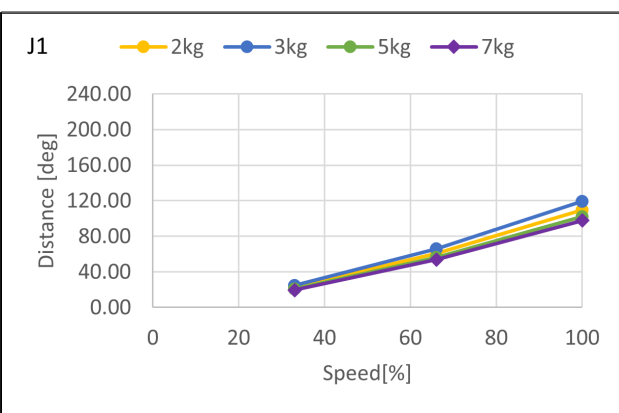
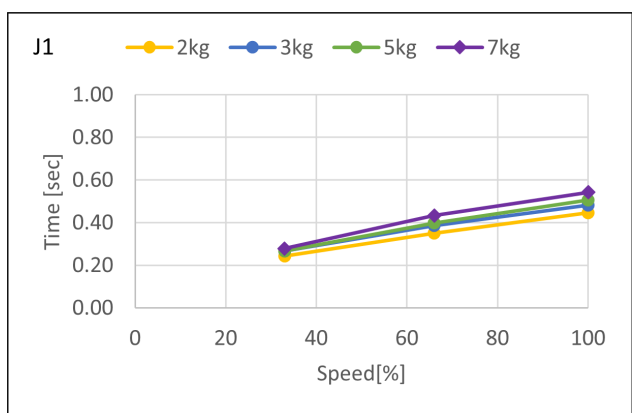

### CX7-A701\*\*\*: J2 (Table top mounting, Ceiling mounting, Wall mounting)

#### Standard mode

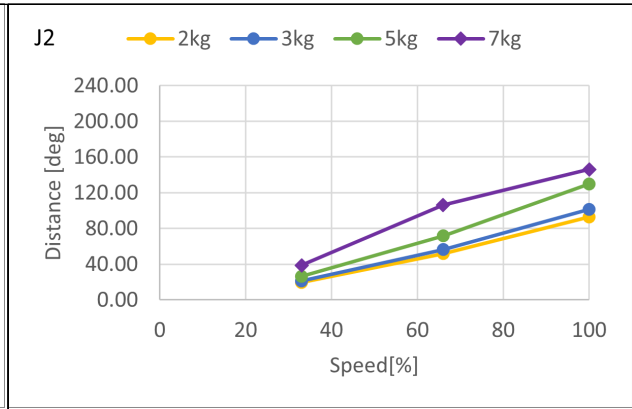
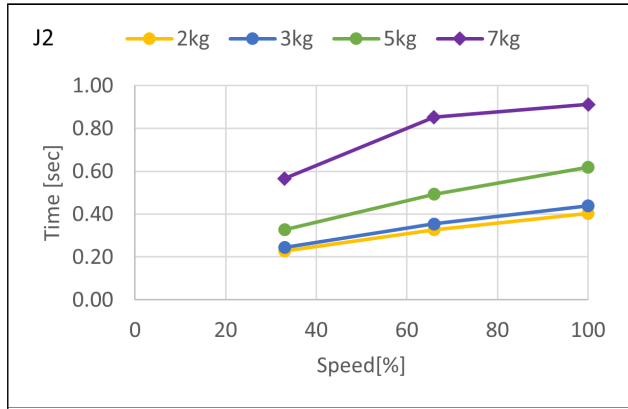

#### Boost mode

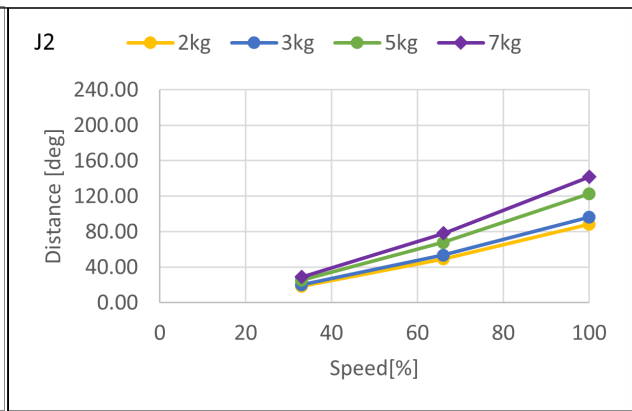
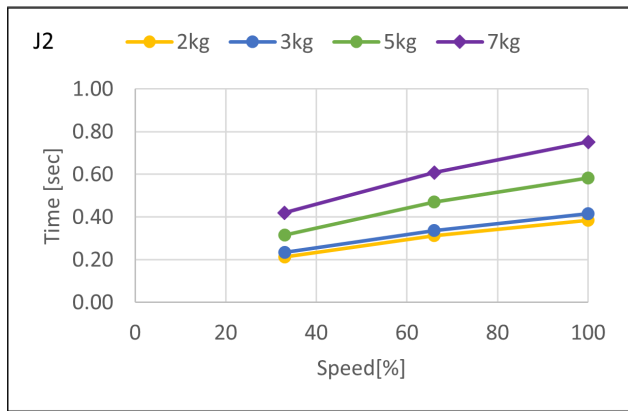

**CX7-A701\*\*\*: J3 (Table top mounting, Ceiling mounting, Wall mounting)**

**Standard mode**

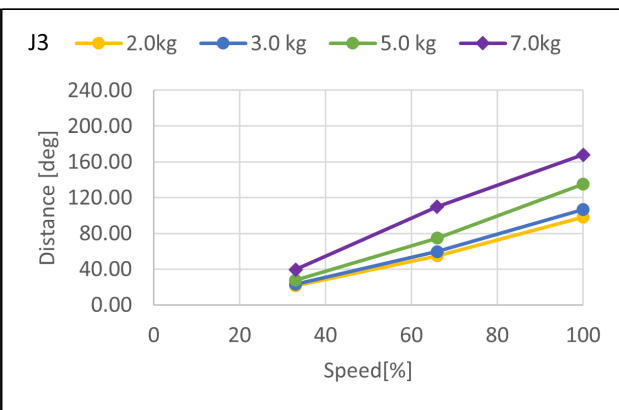
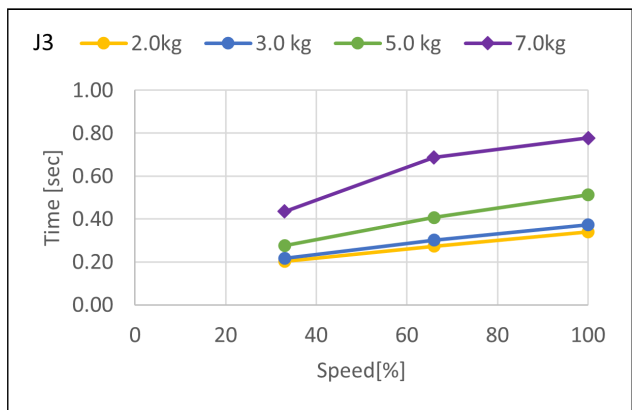

**Boost mode**

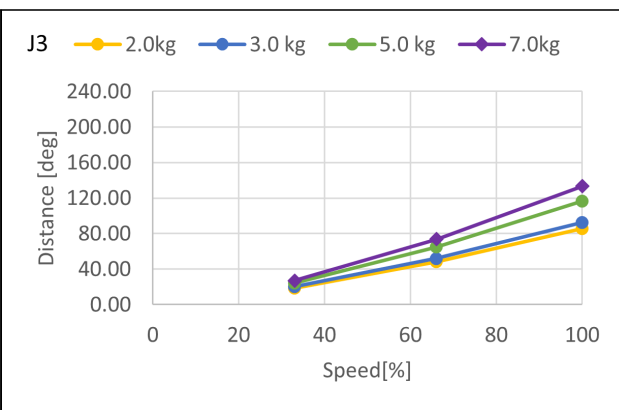
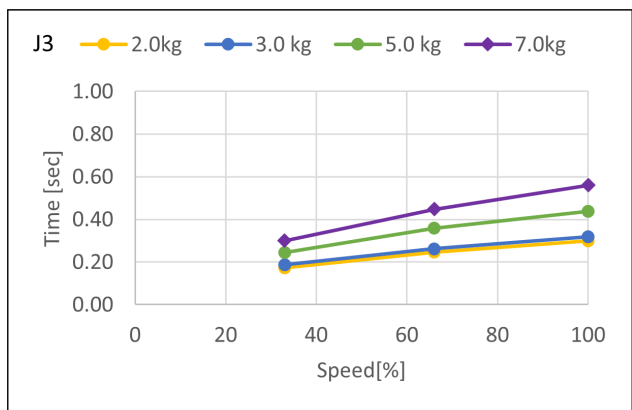

**CX7-A701\*\*\*: J4 (Table top mounting, Ceiling mounting, Wall mounting)**

Standard mode

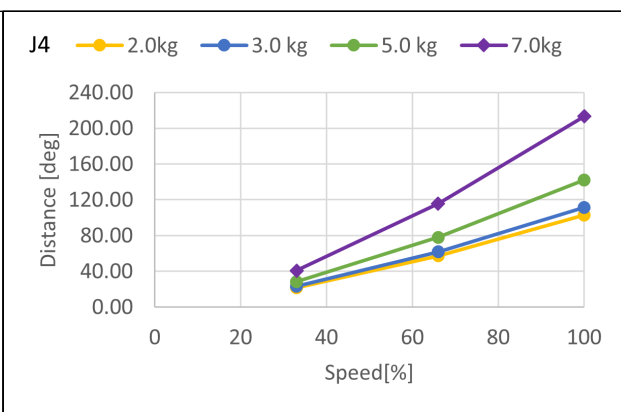
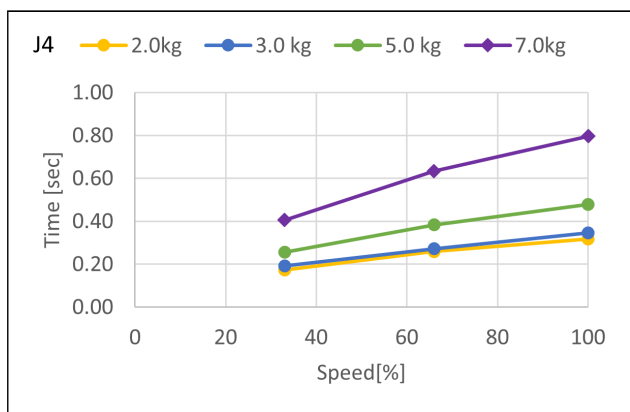

Boost mode

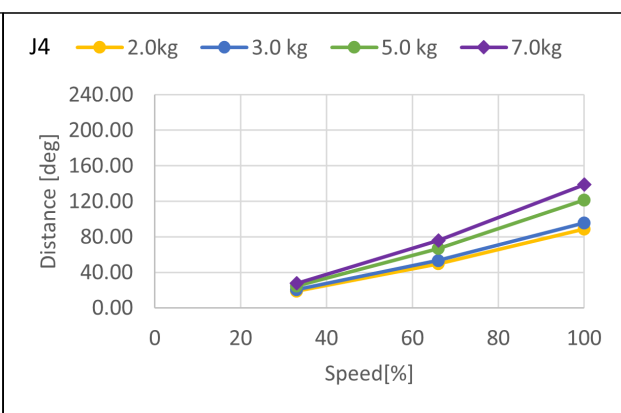
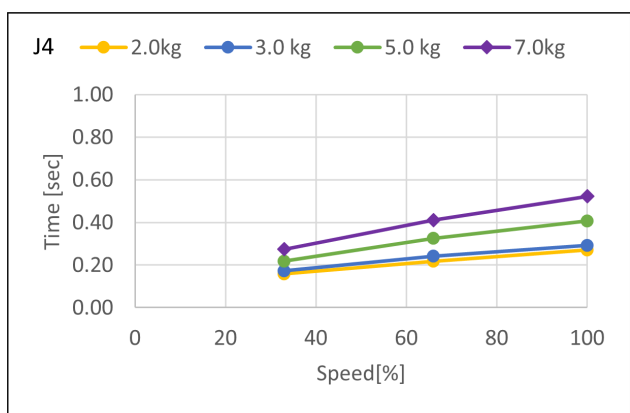

**CX7-A701\*\*\*: J5 (Table top mounting, Ceiling mounting, Wall mounting)**

Standard mode

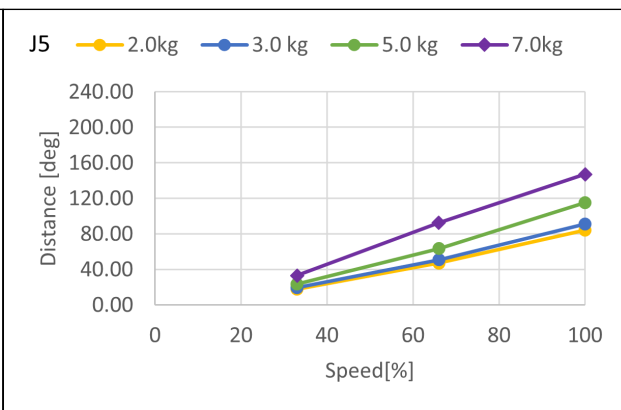
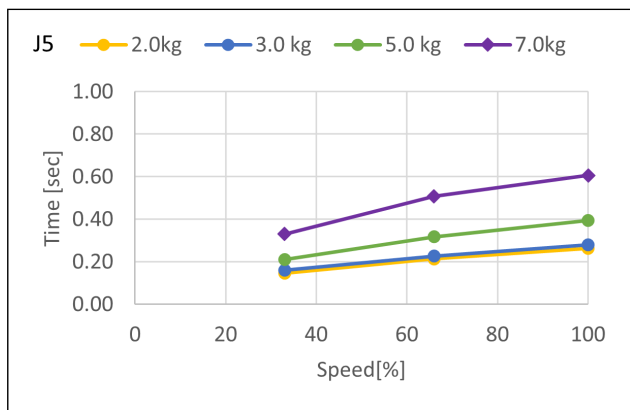

Boost mode

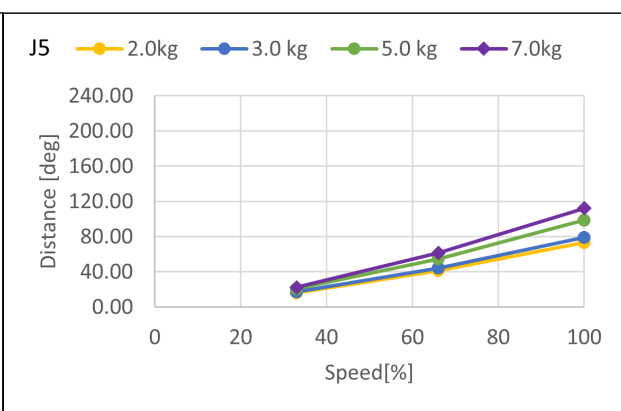
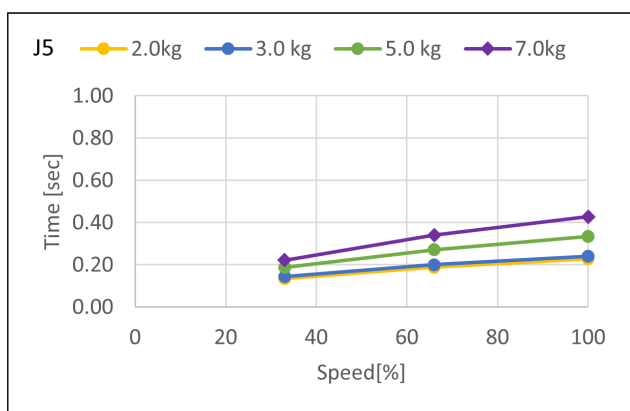

**CX7-A701\*\*\*: J6 (Table top mounting, Ceiling mounting, Wall mounting)**

**Standard mode**

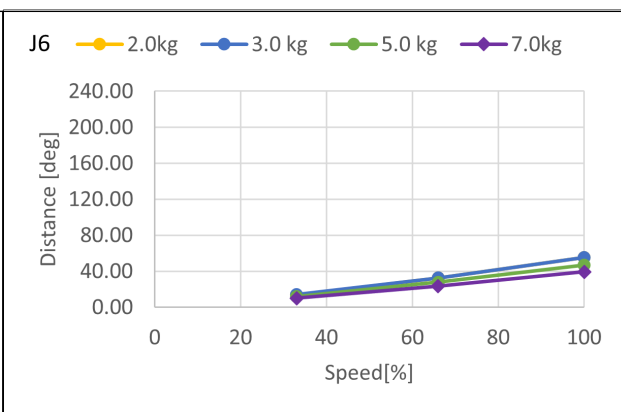
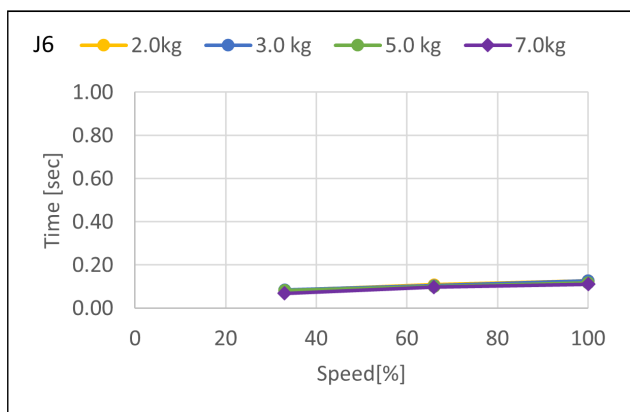

**Boost mode**

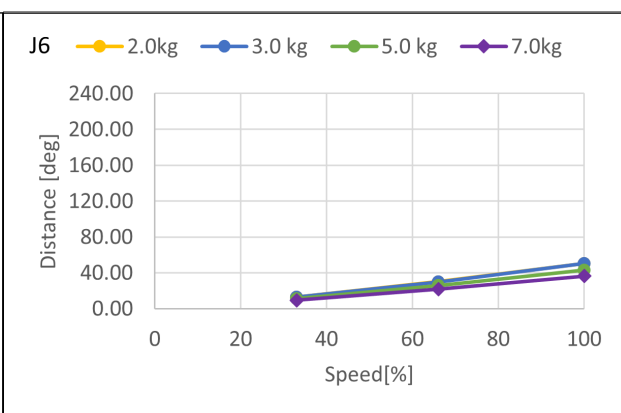
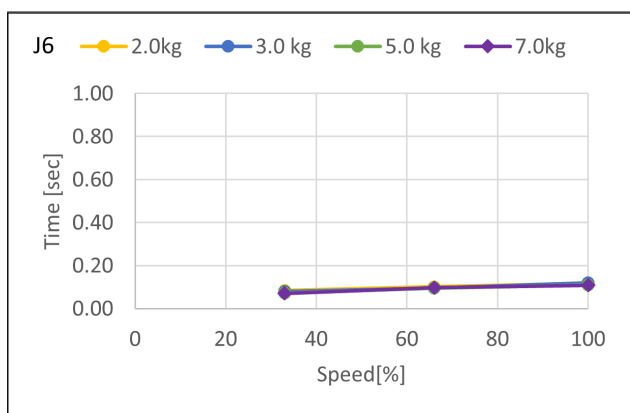

**CX7-A901\*\*\*: J1 (Table top mounting, Ceiling mounting)**

Standard mode

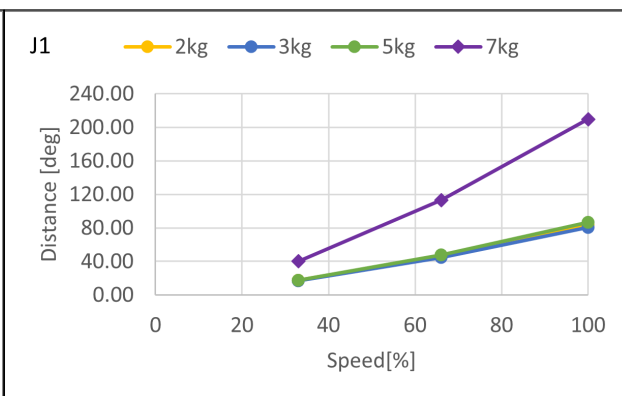
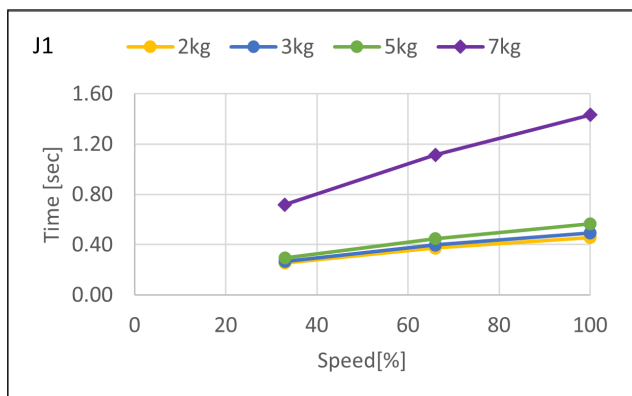

Boost mode

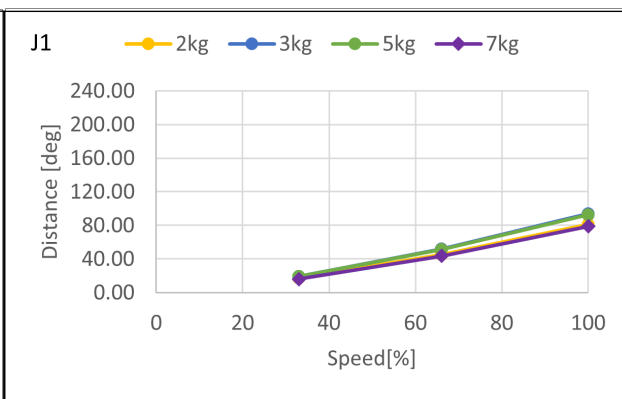
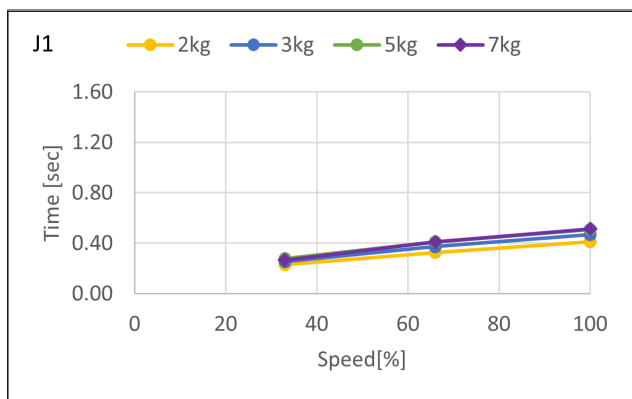

**CX7-A901\*\*\*: J1 (Wall mounting)**

Standard mode

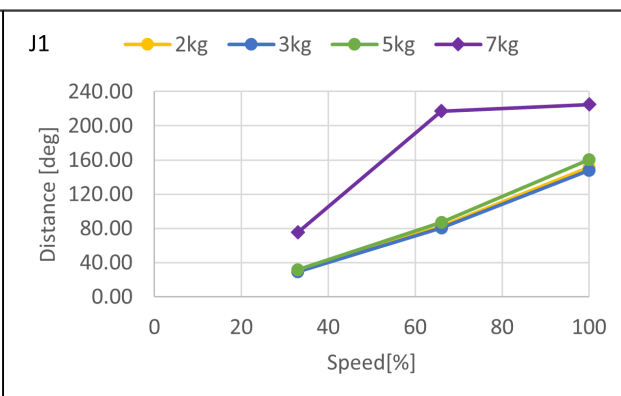
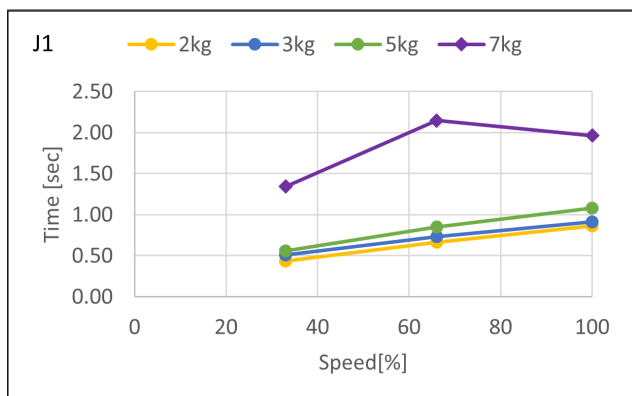

Boost mode

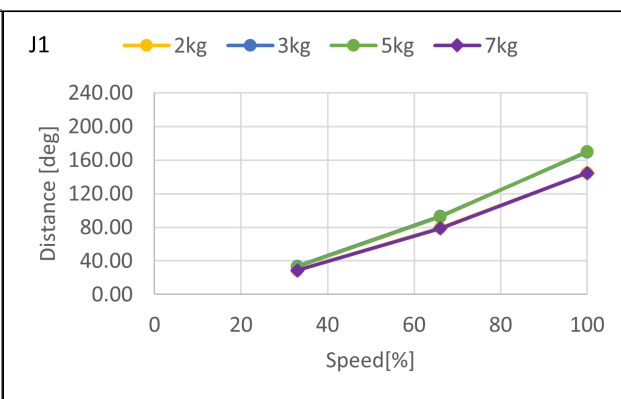
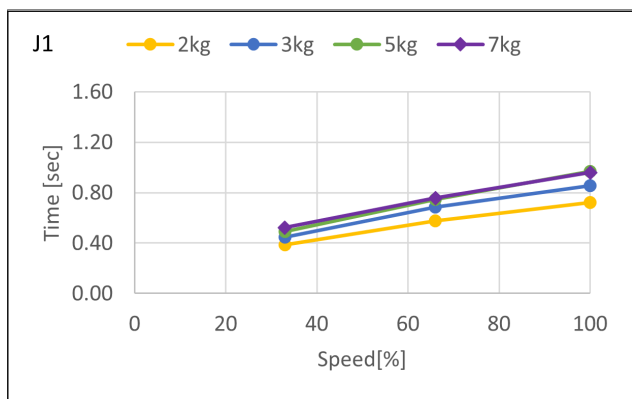

**CX7-A901\*\*\*: J2 (Table top mounting, Ceiling mounting, Wall mounting)**

Standard mode

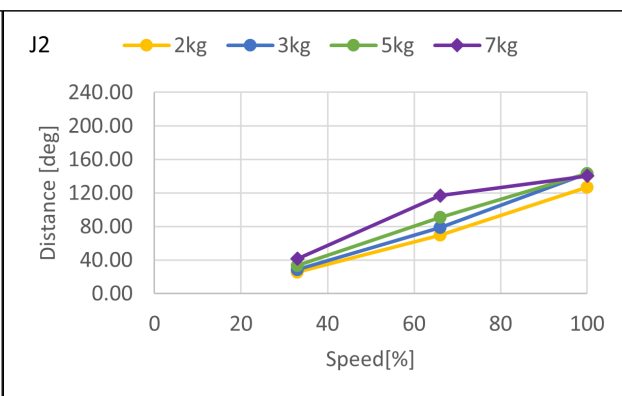
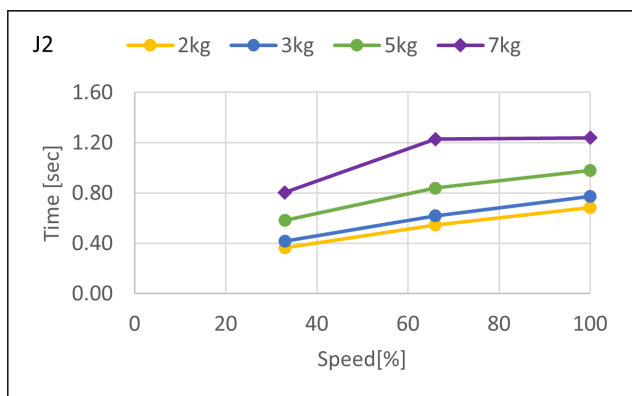

Boost mode

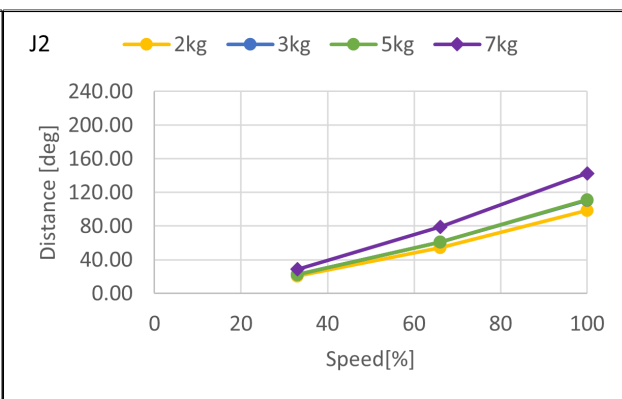
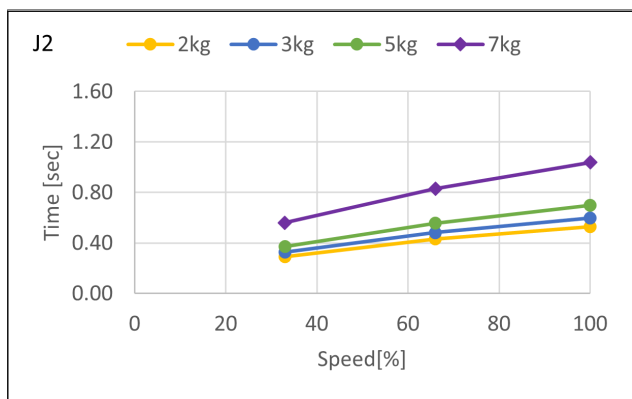

**CX7-A901\*\*\*: J3 (Table top mounting, Ceiling mounting, Wall mounting)**

Standard mode

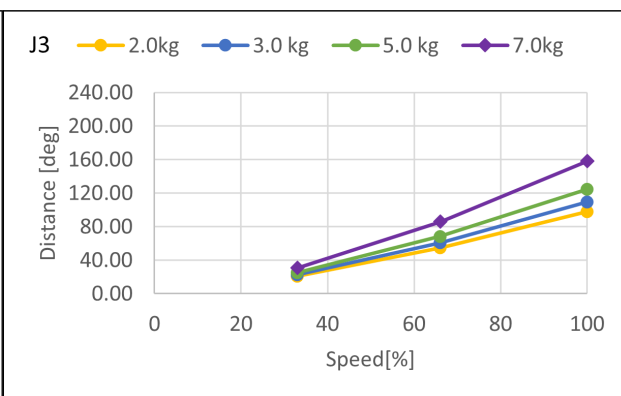
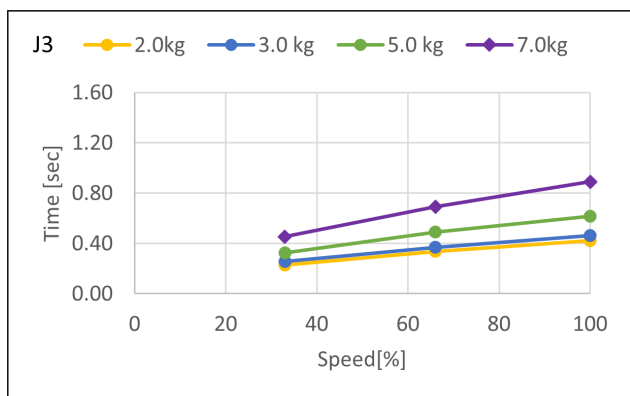

Boost mode

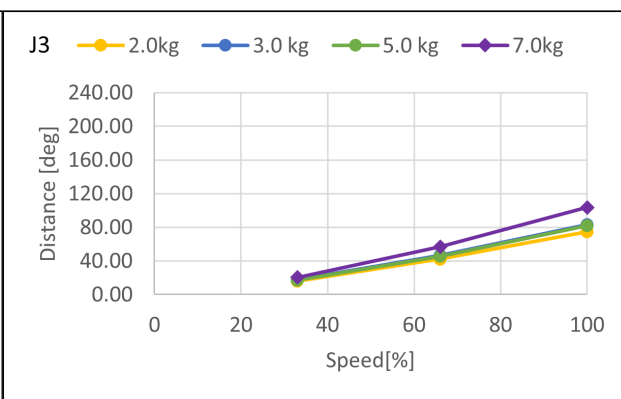
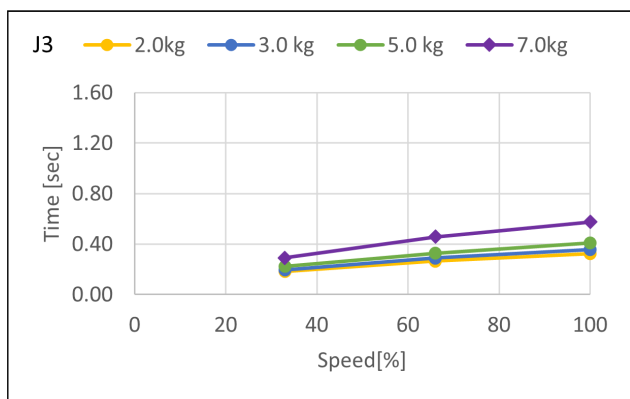

**CX7-A901\*\*\*: J4 (Table top mounting, Ceiling mounting, Wall mounting)**

Standard mode

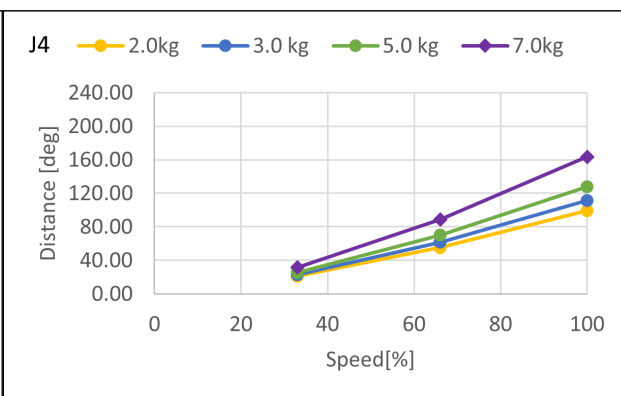
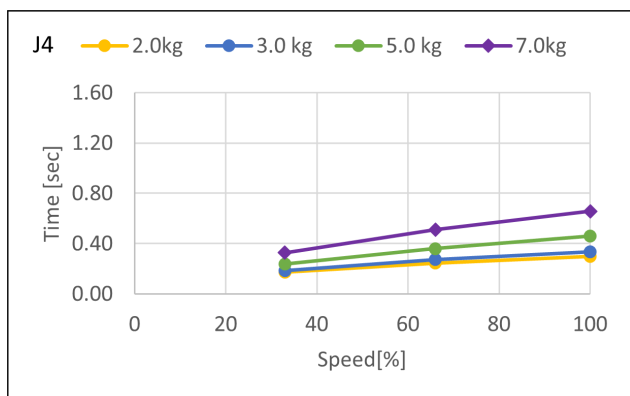

Boost mode

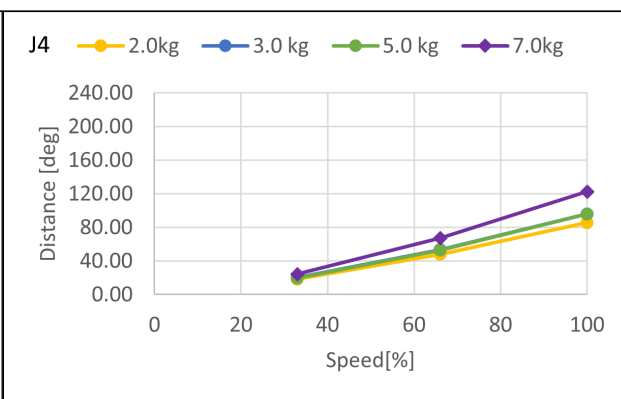
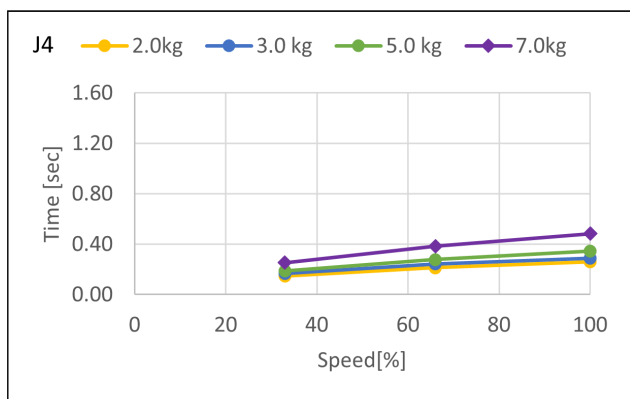

**CX7-A901\*\*\*: J5 (Table top mounting, Ceiling mounting, Wall mounting)**

Standard mode

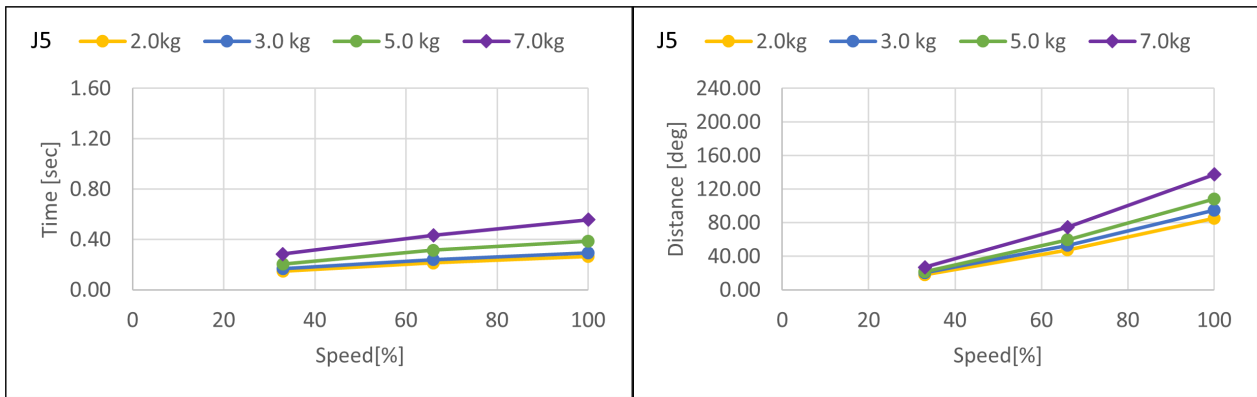

Boost mode

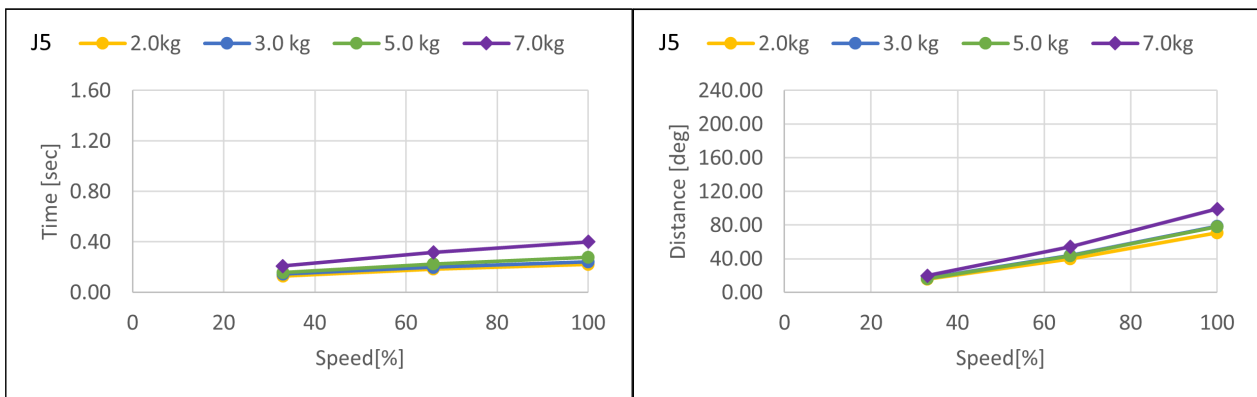

**CX7-A901\*\*\*: J6 (Table top mounting, Ceiling mounting, Wall mounting)**

Standard mode

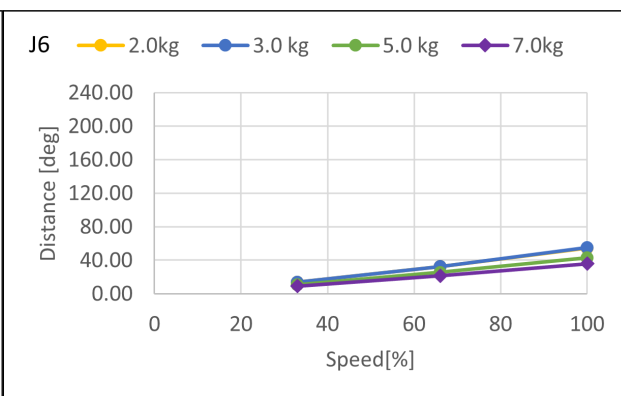
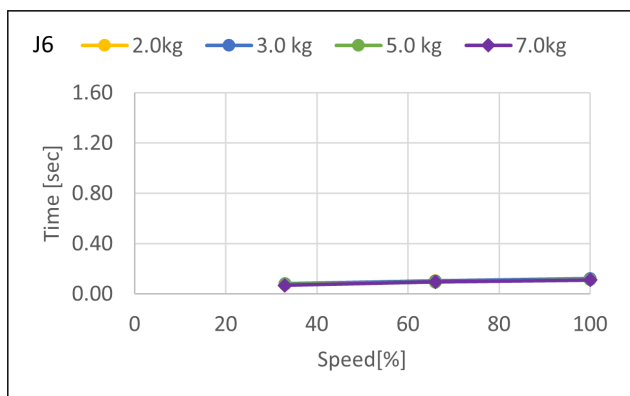

Boost mode

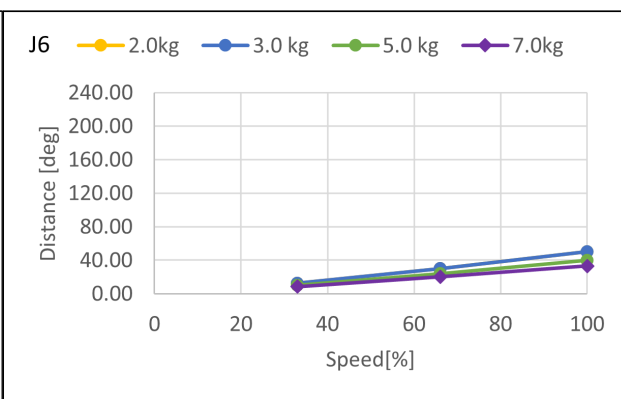
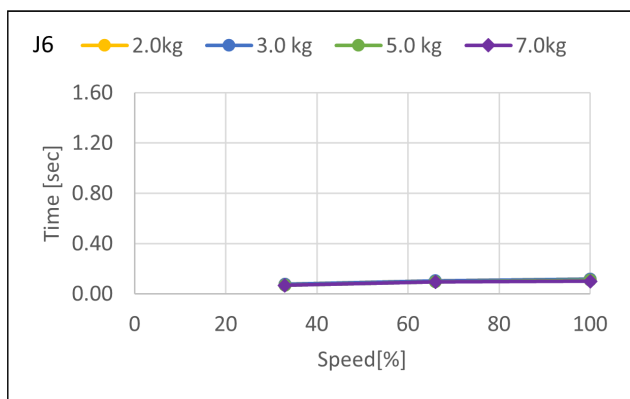

### 5.3.3 Supplementary Information regarding the Stopping Time and Stopping Distance when the Safeguard is Open

The stopping time and stopping distance described in Appendix C was measured by the motion determined by us based on the ISO 10218-1.

Therefore, it does not guarantee the maximum value of the stopping time and stopping distance in the customer's environment. The stopping time and stopping distance differs depending on the robot's model, motion, and input timing of the stop signal. Make sure to always measure the stopping time and stopping distance that matches the customer's environment.

#### KEY POINTS

The following are included in the robot's motion and parameter.

- The motion's starting point, target point, and relay point
- Motion commands (Go, Move, Jump commands etc.)
- Weight and Inertia Settings
- Motion speed, acceleration, deceleration, and one where the motion timing changes

Also, refer to the following description.

CX4:

[WEIGHT and INERTIA Settings](#)

[Safety Information for Auto Acceleration](#)

CX7:

[WEIGHT and INERTIA Settings](#)

[Safety Information for Auto Acceleration](#)

#### 5.3.3.1 How to check the stopping time and stopping distance in the customer's environment

Measure the stopping time and stopping distance of the actual motion with the following method.

1. Create a motion program in the customer's environment.
2. After the motion to check the stopping time and stopping distance starts, input the stop signal at your own timing.
3. Record the time and distance from when the stop signal was input until the robot stopped.
4. Check the maximum stopping time and stopping distance by repeating 1 through 3 mentioned above.
  - How to input the stop signal: Operate the stop switch/safeguard manually or input the stop signal with the safety PLC.
  - How to measure the stopping position: Measure with a tape measure. The angle could also be measured with the Where or RealPos command.
  - How to measure the stopping time: Measure with a stop watch. The Tmr function can also be used to measure the stopping time.

#### CAUTION

The stopping time and stopping distance changes depending on the timing the stop signal is input.

In order to prevent collision with people or objects, perform a risk assessment based on the maximum stopping time and stopping distance and perform an equipment design.

Therefore, make sure to measure the maximum value by changing the timing of the stop signal input during the actual motion and measure repeatedly.

To shorten the stopping time and stopping distance, use the Safety Limited Speed (SLS) and limit the maximum speed.  
For details on the safety limited speed, refer to the following manual.

“Safety Function Manual“

### 5.3.3.2 Commands that can be useful when measuring stopping time and stopping distance

Commands	Functions
Where	Returns the data of the robot's current position
RealPos	Returns the current position of the specified robot * Unlike the motion target position of the CurPos, this obtains the position of the actual robot from the encoder in real time.
PAgl	Returns by calculating the Joint position from the specified coordinate value. P1 = RealPos 'Obtain the current position Joint1 = PAgl (P1, 1) ' Request the J1 angle from the current position
SF_RealSpeedS	Display the current speed from the limited speed position in mm/s.
Tmr	The Tmr function returns the elapsed time from when the timer starts in seconds.
Xqt	Runs the program specified with the function name and complete the task. The function used to measure the stopping time and stopping distance should be used to run tasks that were launched by attaching the NoEmgAbort options. You can run a task that does not stop with the emergency stop and safeguard open.

For more information, refer to the following manual.

"Epson RC+ SPEL+ Language Reference"