

EPSON

Epson RC+ 8.0 Option Part Feeding 8.0 IF-A1520 & IF-A2330

Original instructions

© Seiko Epson Corporation 2025

Rev.2
ENM25ZS8285F

Table of Contents

1. Introduction	5
1.1 Introduction	6
1.2 Trademarks	6
1.3 Terms of Use	6
1.4 Manufacturer	6
1.5 Contact Information	6
1.6 Disposal	7
1.7 Types of Product Manual	7
2. IF-A1520 & IF-A2330 Overview	8
2.1 Features	9
2.2 Safety	9
2.2.1 Conventions	9
2.2.2 Safety Precautions	9
2.2.3 Roles of Machine Users	10
2.3 Transportation, Unpacking and Environment	10
2.3.1 Transportation and Handling of Shipping Box	10
2.3.2 Unpacking	11
2.3.3 Installation Environment	11
2.3.4 Storage Environment	12
3. Specifications	13
3.1 Model	14
3.2 Part Names	14
3.2.1 IF-A1520	14
3.2.2 IF-A2330	15
3.3 Mechanical Specifications	15
3.3.1 Table of Mechanical Specifications	15
3.3.2 Outer Dimensions	16
3.3.3 Mounting Hole Positions	17
3.3.4 Picking Area	18
3.3.5 Maximum Permissible External Force	19
3.3.6 Maximum Plate Displacement	19
3.3.7 Attaching/Removing Platform	20

3.4 Electrical Specifications	21
3.4.1 Table of Electrical Specifications	22
3.4.2 Power Supply	24
3.4.3 LED Indicator	25
3.4.4 Ethernet Interface	26
3.4.5 Hopper Interface	26
3.4.6 Purge Gate Interface	27
3.4.7 Backlight Synchronization Interface	28
3.4.8 Digital I/O Interface	28
3.4.9 Backlight	29
3.4.10 Reset	29
4. Installation	31
4.1 Base Table	32
4.2 Mounting	32
4.2.1 Vibration Isolation	32
5. Options	35
5.1 Option List	36
5.2 Main Unit	36
5.2.1 IF-A1520 MAIN UNIT (R12NZ901P7)	36
5.2.2 IF-A2330 MAIN UNIT (R12NZ901P8)	36
5.3 Standard Platform	37
5.3.1 PLATE STANDARD IF-A1520 (R12NZ901PA)	37
5.3.2 FRAME STANDARD IF-A2330 (R12NZ901P9)	37
5.3.3 PLATE STANDARD IF-A2330 (R12NZ901PB)	37
5.4 Anti-rolling Plate	38
5.4.1 PLATE ANTI-ROLL IF-A1520 (R12NZ901PC)	38
5.4.2 PLATE ANTI-ROLL IF-A2330 (R12NZ901PD)	39
5.5 Purge Gate	39
5.5.1 PURGE UNIT (L) IF-A1520 (R12NZ901PE)	39
5.5.2 PURGE UNIT (R) IF-A1520 (R12NZ901PF)	40
5.5.3 PLATE PURGE STANDARD IF-A1520 (R12NZ901PH)	40
5.5.4 PURGE UNIT IF-A2330 (R12NZ901PK)	41
5.6 Hopper	42

6. Purge Gate	43
6.1 Purge Gates	44
6.2 Purge Gate External Dimensions	44
6.3 Mounting the Purge Gate	47
7. Customize the platform	51
7.1 Platform Type	52
7.2 Dimension of the platform	52
7.2.1 IF-A1520	53
7.2.2 IF-A2330	54
8. Maintenance and Component Replacement	55
8.1 Replacement Parts	56
8.2 Regular Maintenance	56
8.3 Cleaning the Platform	57
9. Troubleshooting	58
9.1 Troubleshooting	59

1. Introduction

1.1 Introduction

Thank you for purchasing this Epson robot system.

This manual contains the information necessary for the correct use of the Epson RC+ Part Feeding option.

Before using the system, read this manual and related manuals to ensure correct use. After reading this manual, store it in an easily accessible location for future reference.

Epson conducts rigorous testing and inspection to ensure that the performance of our robot systems meets our standards. Note that if the Epson robot system is used outside the operating conditions described in the manual, the product will not perform up to its basic performance.

This manual describes possible dangers and consequences that we can foresee. Be sure to comply with safety precautions in this manual to use our robot system safely and correctly.

1.2 Trademarks

Microsoft, Windows, and the Windows logo are either registered trademarks or trademarks of Microsoft Corporation in the United States and/or other countries. All other company names, brand names, and product names are registered trademarks or trademarks of their respective companies.

1.3 Terms of Use

No part of this instruction manual may be reproduced or reprinted in any form without express written permission.

The information in this document is subject to change without notice.

Please contact us if you find any errors in this document or if you have any questions about the information in this document.

1.4 Manufacturer

SEIKO EPSON CORPORATION

1.5 Contact Information

Contact information details are listed in the "Supplier" section in the following manual.

Note that the contact information may vary depending on your region.

"Safety Manual - Contact Information"

The Safety Manual is also available at the following site.

URL: <https://download.epson.biz/robots/>



1.6 Disposal

When disposing of the product, follow the legal regulations of your country.

1.7 Types of Product Manual

These are the main types of manuals for this product and an overview of their contents.

- Safety Manual (Part Feeding)
 - Epson RC+ 8.0 Option Part Feeding F-A1520 & IF-A2330
This manual describes how to use the flexible feeder.
- Epson RC+ 8.0 Option Part Feeding Introduction & Software
This manual describes how to install the flexible feeder and use the software.
- Epson RC+ User's Guide
This manual describes the Project Management and Development Environment in general.
- Epson RC+ SPEL+ Language Reference
This manual describes the SPEL+ robot programming language.
- Other manuals
Manuals are available for each option.

2. IF-A1520 & IF-A2330 Overview

2.1 Features

The F-A1520 & IF-A2330 flexible feeders allow fast and flexible feeding of small parts to a robot equipped with a vision system.

The flexible feeder applies appropriate vibrations to the installed platform, allowing parts on the platform to be moved (forward, backward, sideways) or even flipped.

2.2 Safety

Before using this product, read this manual and related manuals to ensure correct use. After reading this manual, store it in an easily accessible location for future reference.

This product is intended for the transportation and assembly of parts within a secure, isolated area.

2.2.1 Conventions

The following marks are used to indicate safety precautions. Be sure to read them.

WARNING

This symbol indicates that a danger of possible serious injury or death exists if the associated instructions are not followed properly.

WARNING

This symbol indicates that a danger of possible harm to people caused by electric shock exists if the associated instructions are not followed properly.

CAUTION

This symbol indicates that a danger of possible harm to people or physical damage to equipment and facilities exists if the associated instructions are not followed properly.

KEY POINTS

The “KEY POINTS” sections describe important information to be followed for operating this product.

2.2.2 Safety Precautions

Specific allowable values and conditions of use to ensure safety are described in the manuals for the manipulators and controllers. Be sure to read them.

When installing and operating the robot system, strictly observe the safety standards of each country and region.

WARNING

- Never modify the product. Unauthorized modification of this product may cause product failure and could result in injury, electric shock, fire, etc.
- Before performing maintenance on the product, make sure that all power cables and other cables are disconnected from the unit.

CAUTION

Do not operate the system when it is suspected of being damaged. Before use, make visual confirmation that there are no irregularities.

2.2.3 Roles of Machine Users

The following table defines the roles of those involved in the installation and operation of machines.

Group	Conditions	Permitted task
Operator	Read the user manual for this product provided by your system integrator.	Program execution, feeding parts to this product
System integrator	Read the user manual for this product	Install this product and its peripherals onto the completed machine and operate them.
Technician	Read the maintenance chapter in the user manual for this product.	Perform basic maintenance and repairs

2.3 Transportation, Unpacking and Environment

2.3.1 Transportation and Handling of Shipping Box

CAUTION

Unpacking and transportation of the manipulator and related equipment should be handled by someone who has undergone deployment training provided by our company or the distributor. Be sure to follow the laws and regulations of each country.

Follow the instructions printed on the shipping box (upper and lower sides, handling precautions, etc.) during transportation. Observe the following points.

CAUTION

- Be careful of the weight when transporting the system.
- Always hold the system firmly with two hands.
- Workers should not carry heavy shipping boxes by themselves.
- Take due care when handling the product.

- Do not sit or stand on top of the shipping box.
- Do not place heavy objects on top of the shipping box.
- Be careful to avoid damage when transporting the system.
- Always keep the shipping box level.

The table below shows the dimensions and weight of the shipping box.

Weight and dimensions of the product in packaging

	IF-A1520	IF-A2330
Dimensions	430 × 290 × 300 mm	600 × 400 × 380 mm
Total mass	11 kg	31 kg

2.3.2 Unpacking

Observe the following points when unpacking.

CAUTION

- To avoid the risk of dropping or tripping, do not remove the product from the shipping box until you are ready to install it.
- When unpacking, take sufficient safety precautions, such as wearing protective gear (suitable work clothes, helmet, safety shoes, etc.).
- A heavy product should be unpacked by two or more people.
 - IF-A1520: Approx. 9 kg
 - IF-A2330: Approx. 27 kg

2.3.3 Installation Environment

This product can be used under the following conditions.

Operating environment conditions

Item	IF-A1520	IF-A2330
Operating temperature	+5°C to +40°C	
Operating humidity	30% to 80% maximum, no condensation	
Protection class (IP)	IP20	IP50
Cleanliness	Class 7 (ISO14644-1)	—

CAUTION

- Do not use the product in an atmosphere of corrosive gases. Rust may form and reduce the structural strength of the product.
- Do not use the product in a place where it may come in contact with water or oil droplets.

- Avoid extreme electromagnetic waves, ultraviolet rays and radiation.

KEY POINTS

Note that changes in temperature and humidity may affect the overall performance of this product.

2.3.4 Storage Environment

Store the product under the following conditions. Protect it from dust.

Storage environment conditions

Item	Value	
	IF-A1520	IF-A2330
Storage temperature	+5°C to +40°C	
Storage humidity	30% to 80% maximum, no condensation	

3. Specifications

3.1 Model

Model

Product name	Specification	Model number
IF-A1520 STANDARD KIT	<ul style="list-style-type: none"> ▪ IF-A1520 main unit ▪ Platform (standard plate) ▪ Power cable, Ethernet cable 	R12NZ901P5
IF-A2330 STANDARD KIT	<ul style="list-style-type: none"> ▪ IF-A2330 main unit ▪ Platform (standard plate, plate frame) ▪ Power cable, Ethernet cable 	R12NZ901P6

3.2 Part Names

3.2.1 IF-A1520

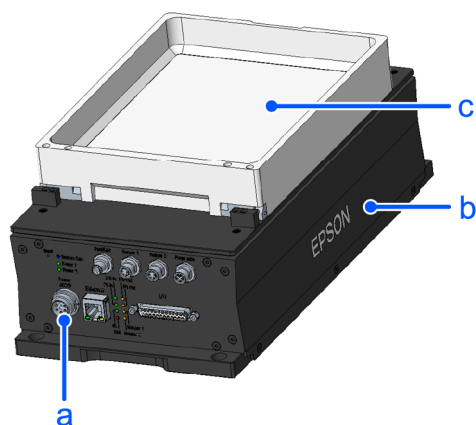

Symbols	Meaning
a	Power and interface connectors
b	IF-A1520 main unit
c	Platform (standard plate)

3.2.2 IF-A2330

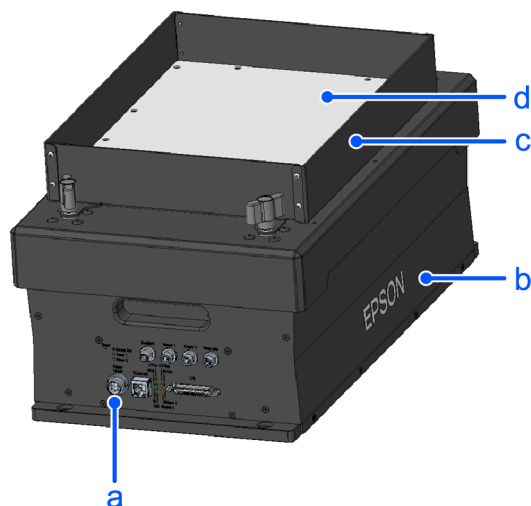

Symbols	Meaning
a	Power and interface connectors
b	IF-A2330 main unit
c	Platform (plate frame)
d	Platform (standard plate)

3.3 Mechanical Specifications

3.3.1 Table of Mechanical Specifications

Table of Mechanical Specifications

Item	IF-A1520	IF-A2330	Notes
Machine name	Flexible feeder		
Product size	330 × 172 × 129 mm	480 × 292 × 249 mm	See below. Outer Dimensions
Product mass	9 kg	27 kg	
Recommended part size	Length of long side 5 to 40 mm	Length of long side 15 to 60 mm	*1
Range of vibration frequency variation	20 Hz to 80 Hz (1 Hz steps)	15 Hz to 35 Hz (1 Hz steps)	
Picking area	195 × 150 mm	300 × 230 mm	See below. Picking Area
Fixing screw size	M6	M8	See below. Mounting Hole Positions
Maximum Permissible External Force	Fx: 10 N Fy: 10 N Fz: 20 N	Fx: 10 N Fy: 10 N Fz: 30 N	See below. Maximum Permissible External Force
Maximum load weight (parts)	0.4 kg	1.5 kg	

Item	IF-A1520	IF-A2330	Notes
Maximum platform weight	1.35 kg	4 kg	*2
Maximum Plate Displacement	X direction: ± 1.5 mm Y direction: ± 1.5 mm Z direction: ± 1.5 mm	X direction: ± 3.5 mm Y direction: ± 4.5 mm Z direction: ± 4.5 mm	See below. Maximum Plate Displacement
Repeatability in plate Z direction	≤ 0.02 mm	≤ 0.4 mm	
Noise level	<76 dB(A)	<80 dB(A)	*3

*1. Before use, operate the flexible feeder to feed actual parts, and make the checks below. Parts that cannot achieve these are not suitable for flexible feeders.

- The parts disperse.
- The parts move.
- The overlapping of parts has been eliminated.

*2. This is the mass limit for customers customizing the platform. Note that this limit is the total mass of the platform and payload.

CAUTION

The customer is responsible for customizing the platform.
If you wish to modify the platform, remove it from the main unit by following the instructions below.

[Attaching/Removing Platform](#)

*3. The conditions for noise measurements are shown below.

- No parts loaded on the platform
- Equivalent noise level (LAeq) measured at a distance of 1000 mm from the product

CAUTION

The noise level may be high due to parts vibrating on the platform. In this case, the customer or system integrator is responsible for implementing any measures necessary to meet the operator's safety requirements.

3.3.2 Outer Dimensions

(Unit: mm)

IF-A1520

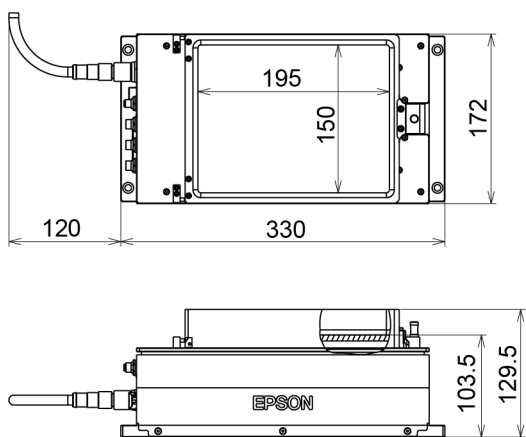

IF-A2330

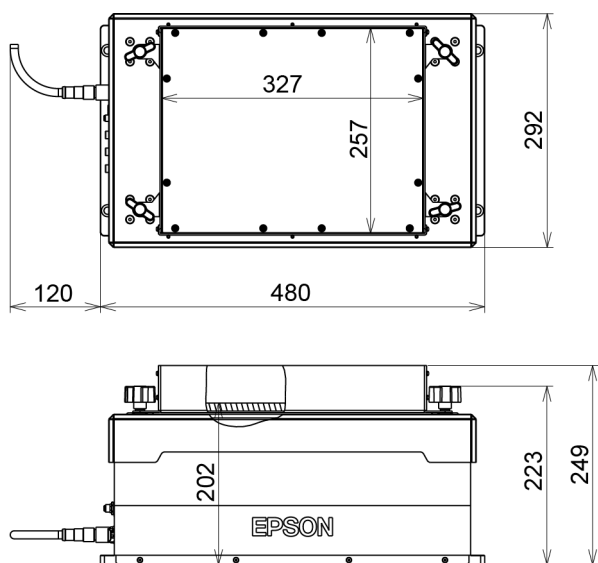

3.3.3 Mounting Hole Positions

(Unit: mm)

IF-A1520

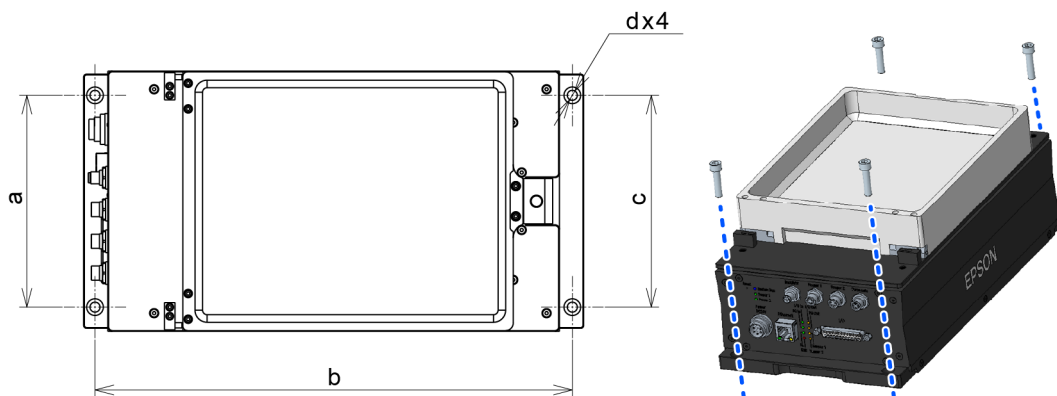

Fixing screw: M6 × 4

IF-A2330

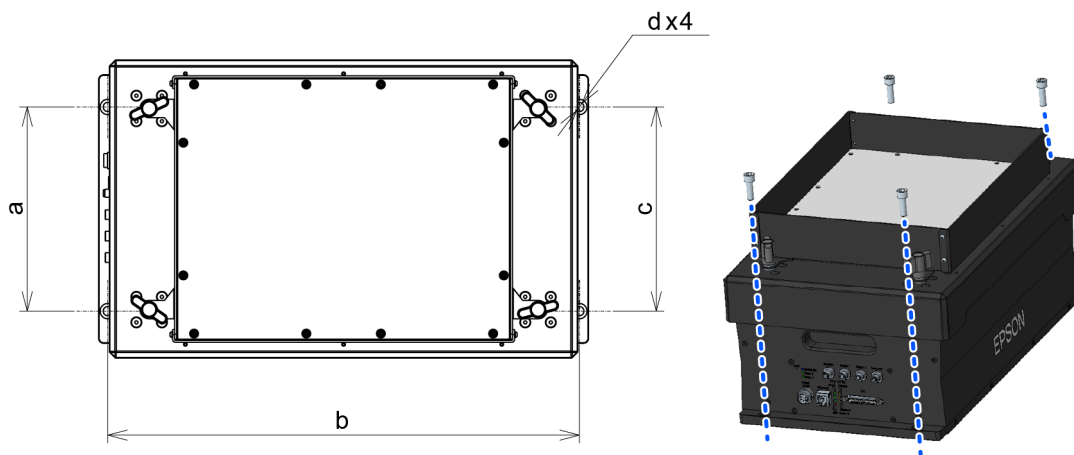

Fixing screw: M8 × 4

	a	b	c	d
IF-A1520	140	315	140	ø6.6
IF-A2330	200	462	200	ø9

3.3.4 Picking Area

(Unit: mm)

The picking area is the area on the platform plate surface where parts can be picked.

IF-A1520

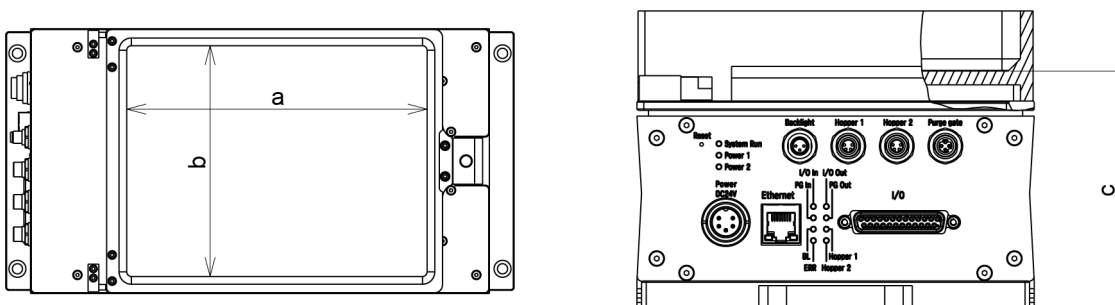

IF-A2330

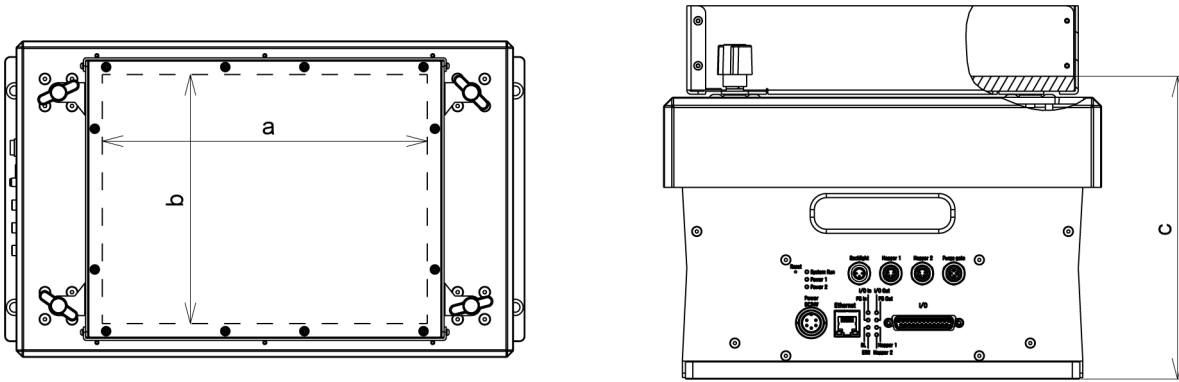

	a (picking area)	b (picking area)	c (picking surface height)
IF-A1520	195	150	103.5 (reference)
IF-A2330	300	230	202 (reference)*

*The picking surface height of the IF-A2330 purge gate specification differs from the standard specification (see [Purge Gate External Dimensions](#)).

3.3.5 Maximum Permissible External Force

This is the maximum force that can be applied to the platform plate and plate frame. This is a guideline for the pressing force applied by the robot hand or gripper.

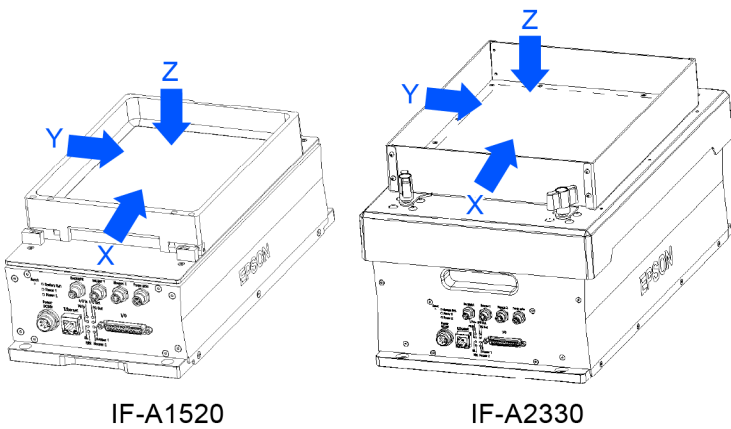

IF-A1520

IF-A2330

Maximum permissible external force (pressing force)

	Fx	Fy	Fz
IF-A1520	10 N	10 N	20 N
IF-A2330	10 N	10 N	30 N

3.3.6 Maximum Plate Displacement

(Unit: mm)

This is the maximum displacement that can occur on the platform plate due to vibrations.

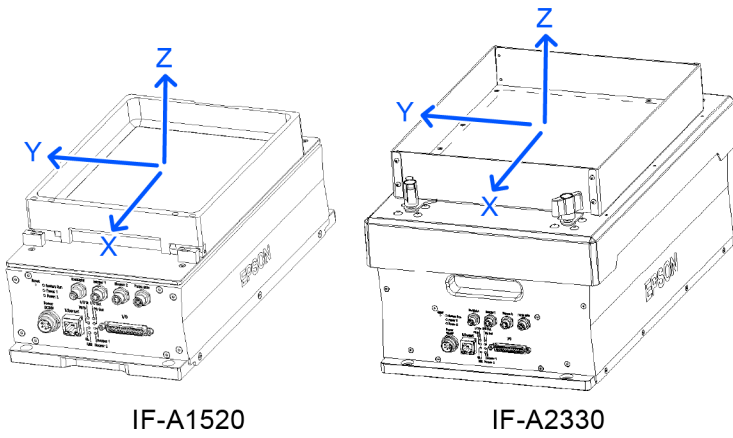

Maximum Plate Displacement

	X direction	Y direction	Z direction
IF-A1520	±1.5	±1.5	±1.5
IF-A2330	±3.5	±4.5	±4.5

3.3.7 Attaching/Removing Platform

⚠ CAUTION

- Be sure that the backlight is off before removing the platform module. If you attempt to remove the platform without first turning off the backlight, the backlight may be damaged.
- Do not place your finger between the platform and the locking mechanism. Crushing hazard.

IF-A1520

1. Pull out the lever (a).
2. Pull the lever down away from the platform. This will release the platform's lock.
3. Pull out the platform.

Reverse the procedure when attaching the platform. Furthermore, the handle screw comes with an M6 spring washer and washer. Do not forget to attach them when attaching the platform.

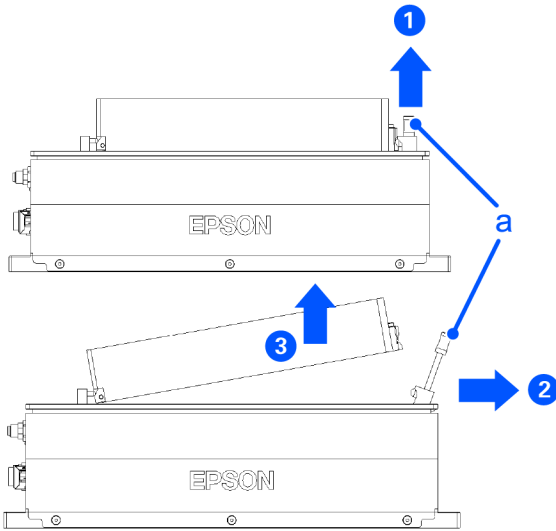

IF-A2330

- 1. Remove the four handle screws (a) that secure the platform.
- 2. Remove the platform.

Reverse the steps to install the platform. Furthermore, the handle screw comes with an M6 spring washer and washer. Do not forget to attach them when attaching the platform.

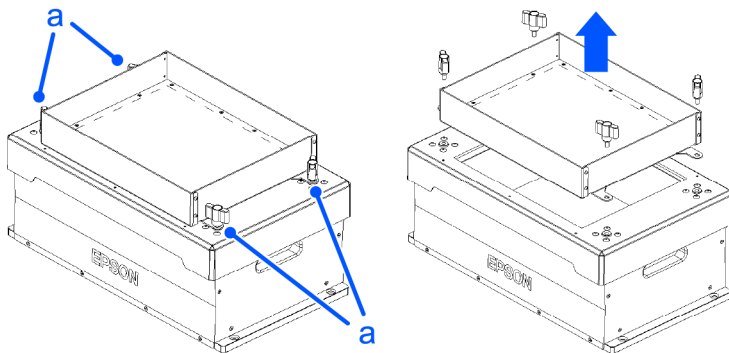

3.4 Electrical Specifications

⚠ CAUTION
Wiring should be performed by a certified technician or qualified person.
Wiring work by inexperienced persons may result in injury or breakdown. Also, be sure to install wiring in a way that will not cause people to trip or fall over it.

✎ KEY POINTS
Make sure that the Duty ratio between the vibration time and stopping time of the flexible feeder is approximately 50:50 or less. When vibration occurs continuously, operation may be stopped by the protective function.

3.4.1 Table of Electrical Specifications

Item		IF-A1520	IF-A2330	Reference
Voltage		24 VDC \pm 5%	24 VDC \pm 5%	Power Supply
Rated current		8 A	9A	
Interface	Ethernet	1 (100Base-TX)	1 (100Base-TX)	Ethernet Interface
	Hopper	2	2	Hopper Interface
	Purge gate	1	1	Purge Gate Interface
	Backlight synchronization	1	1	Backlight Synchronization Interface
	Digital I/O	1	1	Digital I/O Interface
Backlight	Color	White and red	White and red	Backlight
	Brightness	\geq 1000 nits (cd/m ²)	\geq 1000 nits (cd/m ²)	

IF-A1520

IF-A2330

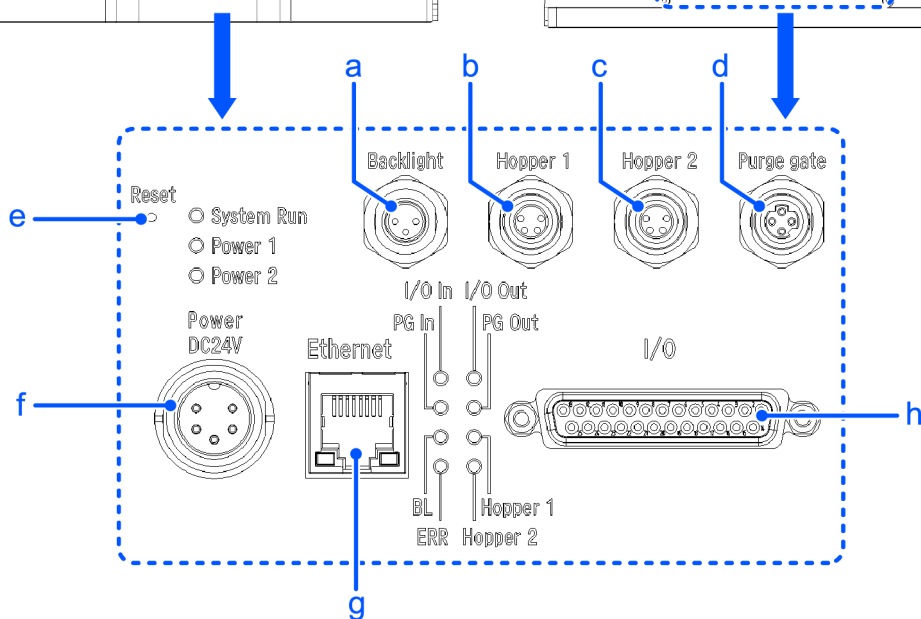
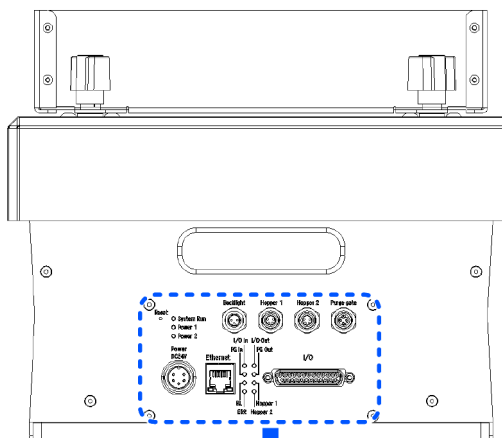
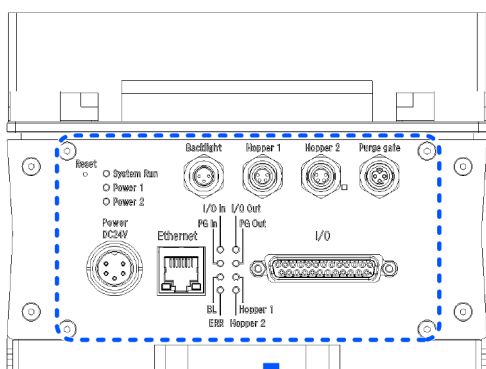

IF-A1520

IF-A2330



Symbols	Meaning
a	Backlight synchronization
b	Hopper 1
c	Hopper 2
d	Purge gate
e	Reset

Symbols	Meaning
f	Power supply
g	Ethernet
h	Digital I/O
i	Backlight

3.4.2 Power Supply

⚠ CAUTION

Make the checks below before supplying power to the flexible feeder.

- Ensure that the distribution voltage used is the same as the specified supply voltage.
- Use a PELV (Protected Extra Low Voltage) circuit to supply the voltage.
- Make sure that the plug connected to the 24 VDC interface has the correct polarity.
- Do not connect the IF-80 and IF-240 power cables to the IF-A1520 and IF-A2330 power connectors.

✍ KEY POINTS

- Connect both Power and S-Power to the power supply when operating the flexible feeder. Both Power and S-Power can be connected to a single power supply or to two different power supplies.
- You are recommended to provide a dedicated power source for each flexible feeder.
- Operation has been confirmed with the following power supplies.
 - PULS QS20.241
 - SIEMENS 6EP1336-3BA10
 - OMRON S8VK-S48024

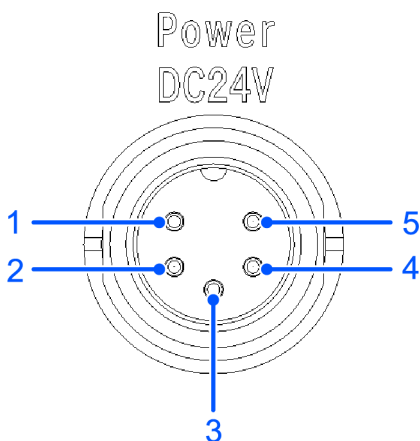

Pin	Name	Description
1	Power 24V	Main power supply (24 VDC)
2	Power 0V	Main power supply (GND)
3	S-Power 24V	Backlight power supply (24 VDC)

Pin	Name	Description
4	S-Power 0V	Backlight power supply (GND)
5	PE	EARTH

Connector on flexible feeder: Standard M16, 5 poles (male)

		IF-A1520	IF-A2330
Power	Voltage	24 VDC ±5%	24 VDC ±5%
	Rated current	6 A	6A
S-Power	Voltage	24 VDC ±5%	24 VDC ±5%
	Rated current	2 A	3A

3.4.3 LED Indicator

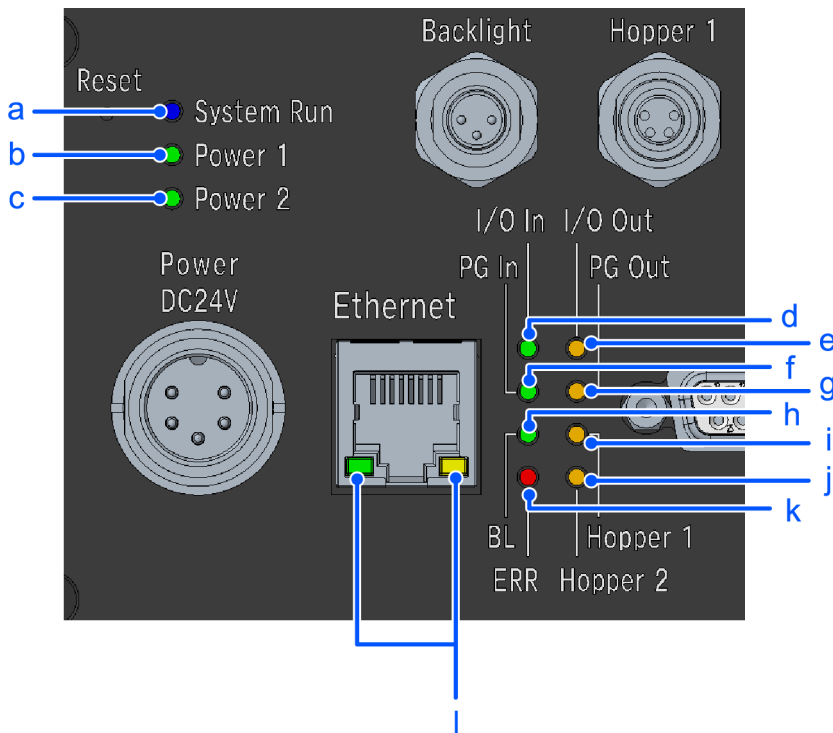

LED	Name	Color	Function	Description
a	System Run	Blue	System status	Slow flashing: system in operation Fast flashing: firmware updating
b	Power 1	Green	Power supply (Power)	Lit: 24 V power supplied
c	Power 2	Green	Power (S-Power)	Lit: 24 V S-Power supplied
d	I/O In	Green	Digital I/O input	Unused (Reserve)
e	I/O Out	Orange	Digital I/O output	Unused (Reserve)
f	PG In	Green	Purge gate input	Lit: Purge gate closed
g	PG Out	Orange	Purge gate output	Lit: Purge gate opening

LED	Name	Color	Function	Description
h	BL	Green	Backlight synchronization	Lit: Backlight synchronization signal input
i	Hopper 1	Orange	Hopper 1 output	Lit: Hopper 1 in operation
j	Hopper 2	Orange	Hopper 1 output	Lit: Hopper 2 in operation
k	ERR	Red	Error status	Lit: System error occurred
l	Ethernet	Green/Yellow	Communication status	Lit/flashing: Ethernet communications status

3.4.4 Ethernet Interface

Communication with the flexible feeder is performed by standard TCP/IP communication via the RJ45 port.

RJ45 Port

Ethernet

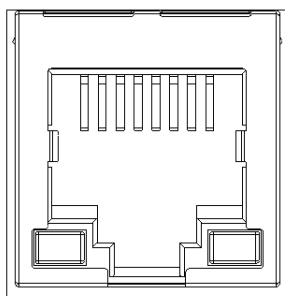

IP address setting

Item	Value
Default IP address	192.168.0.64
Default subnet mask	255.255.255.0
Port number	4001

For information on restoring the default IP address, refer to the following.

[Reset](#)

3.4.5 Hopper Interface

Up to two hoppers can be connected to supply parts to the flexible feeder.

The hoppers that can be connected are described below.

[Options](#)

Hopper 1

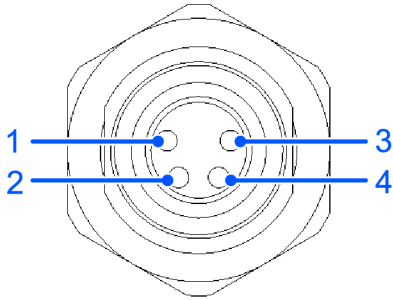

Pin	Name	Description
1	AGND	Analog output (GND)
2	AOUT	Analog output (0 to 10 VDC)
3	COM	Digital output (GND)
4	DOUT	Digital output (24 VDC)

Connector on flexible feeder: Standard M8, 4 poles (female, Code-A)

3.4.6 Purge Gate Interface

To eject the parts from the platform, the standard platform can be changed to a platform with purge gate. The purge gate interface supplies and controls the power to the platform with purge gate.

Purge gate

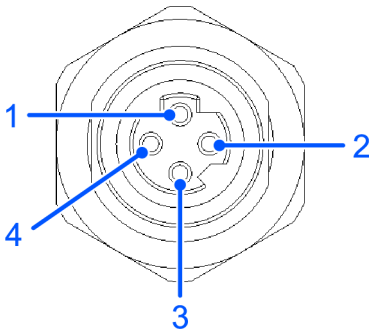

Pin	Name	Description
1	DC24V	Power supply (24 VDC)
2	DIN	Digital input (closed purge gate detected)
3	COM	Power supply (GND)
4	DOUT	Digital Output (purge gate control)

Connector on flexible feeder side: Standard M8, 4 poles (female, Code-D)

3.4.7 Backlight Synchronization Interface

Input signal for turning on the backlight in sync with the camera. The backlight lights while 24 VDC is being input to the STROBE terminal.

For information about the backlight, see below.

Backlight

Backlight

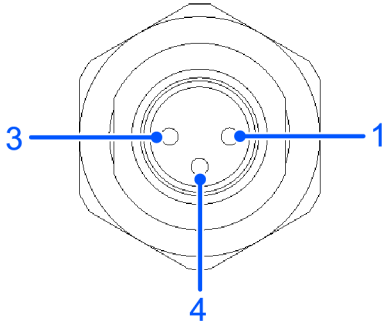

Pin	Name	Description
1	NC	Not used
3	COM	Backlight input (GND)
4	STROBE	Backlight input (24 VDC)

Connector on flexible feeder: Standard M8, 3 poles (male)

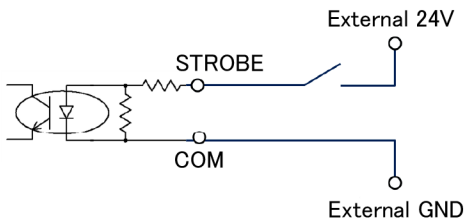

3.4.8 Digital I/O Interface

Do not use the digital I/O interface (reserve port).

I/O

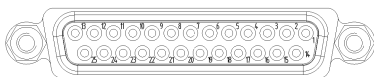

3.4.9 Backlight

⚠ CAUTION

As the LEDs used for backlighting fall under the EN 62471 exempt group and the exemption level (RG0) of GB 44703-2024, this product can be handled without any special consideration. If it is determined that countermeasures are required for the backlighting, the customer is responsible for implementing the protective measures.

The flexible feeder is equipped with the backlight under the platform. The backlight supports white and red light. The color, brightness, illumination timing can be changed through software settings.

White and red light illumination are not possible at the same time. For details about the backlight settings, see below.

"Epson RC+ 8.0 Option Part Feeding 8.0 Introduction & Software"

The illumination timing can also be controlled by an external signal. See details below.

Backlight Synchronization Interface

IF-A1520

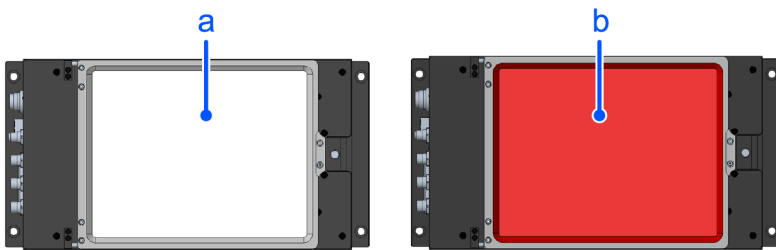

IF-A2330

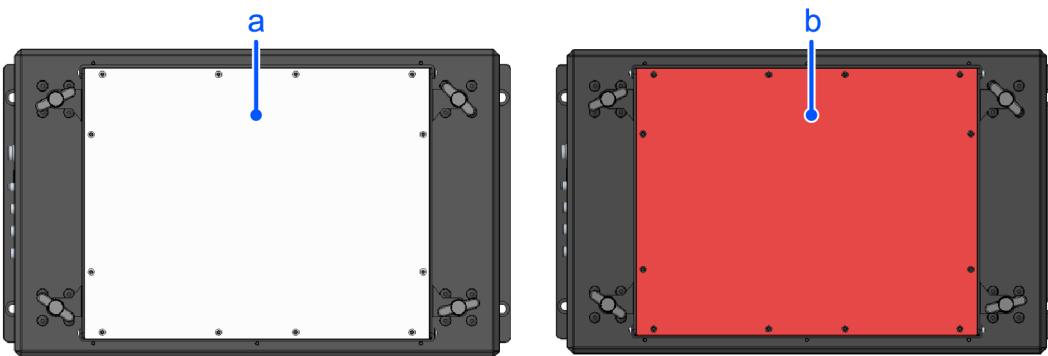

Symbol	Description
a	White backlight
b	Red backlight

3.4.10 Reset

Press the reset switch (a) to reset the IP address, netmask, and port number to their default values.

For the reset switch, insert a straight wire into the hole vertically. The wire is not supplied with the product.

The default values are shown below.

Ethernet Interface

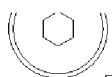

Reset



System Run

Power 1

Power 2

4. Installation

4.1 Base Table

To ensure normal vibrational behavior of the flexible feeder, it is important to correctly secure the flexible feeder on a base table specifically designed for the application. The flexible feeder must be installed either on a rigid base table screwed to the floor or on an unsecured but heavy base table.

Make sure the base table surface on which the flexible feeder is mounted is level.

4.2 Mounting

CAUTION

Correctly secure the flexible feeder to the base table. It can fall off if not secured correctly.

KEY POINTS

The product's performance may be reduced if the product is not secured correctly by not using all four screws, not installing it on a horizontal surface, or leaving a gap between the product and the base table.

For information on the mounting holes on the base table, see below.

Mounting Hole Positions

The screws for mounting to the base table are not supplied with the product. To be provided by the customer.

Fixing screw

	Fixing screw size	Tightening torque
IF-A1520	M6	9 N·m
IF-A2330	M8	22 N·m

4.2.1 Vibration Isolation

Incorrect mounting of the flexible feeder, camera, robot, and hopper may compromise the final system performance. To ensure the normal behavior of a system, it is necessary to avoid that all the involved devices can interfere with each other.

If several moving devices are assembled in parallel, and close to each other, it is necessary to “decouple the vibrations”, to avoid that behavior of any product is disturbed by the movement of others. When two or more flexible feeders are installed close to each other, the operating feeder may affect ones that are not working. You are recommended to install the feeders far enough apart to prevent interference between them.

Bad example: Devices interfere with each other

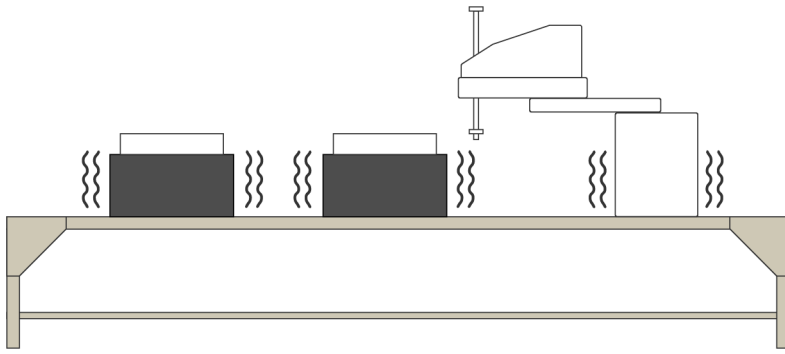
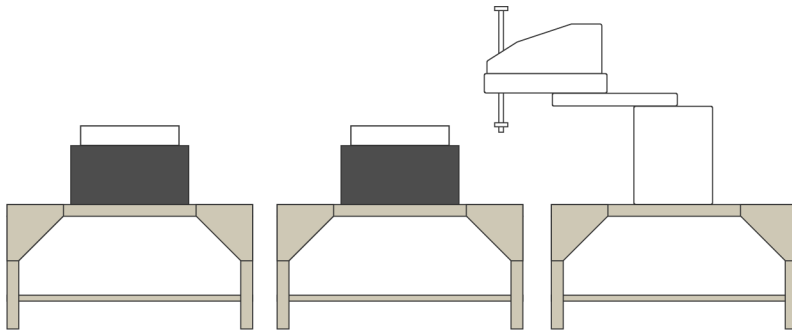
**Good example: Devices do not interfere with each other**

It is important that the camera is not affected by the vibrations of the flexible feeder or another moving device. If the vision system is affected by residual vibrations, unreliable coordinate data sent to the robot may compromise the precision of the whole system.

Therefore, you are recommended not to mount the flexible feeder and camera on the same base table. If mounting this way is not possible, mount the camera on a base table that is rigid and heavy enough to prevent vibrations from affecting surrounding equipment.

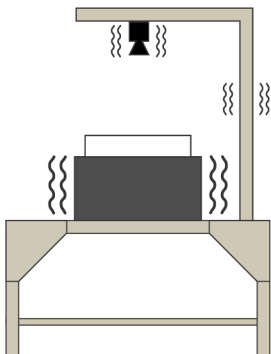
Bad example: Vibrations from a flexible feeder interfere with the camera**Good example: Vibrations from a flexible feeder do not interfere with the camera**

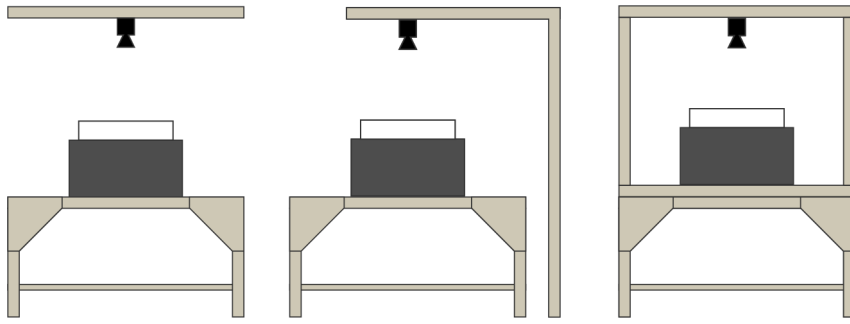

5. Options

5.1 Option List

Model

Product name	Model number
IF-A1520 MAIN UNIT	R12NZ901P7
IF-A2330 MAIN UNIT	R12NZ901P8
PLATE STANDARD IF-A1520	R12NZ901PA
FRAME STANDARD IF-A2330	R12NZ901P9
PLATE STANDARD IF-A2330	R12NZ901PB
PLATE ANTI-ROLL IF-A1520	R12NZ901PC
PLATE ANTI-ROLL IF-A2330	R12NZ901PD
PURGE UNIT (L) IF-A1520	R12NZ901PE
PURGE UNIT (R) IF-A1520	R12NZ901PF
PLATE PURGE STANDARD IF-A1520	R12NZ901PH
PURGE UNIT IF-A2330	R12NZ901PK

5.2 Main Unit

5.2.1 IF-A1520 MAIN UNIT (R12NZ901P7)

Option for the IF-A1520 main unit only. The power cable and Ethernet cable are supplied.



5.2.2 IF-A2330 MAIN UNIT (R12NZ901P8)

Option for the IF-A2330 main unit only. The power cable and Ethernet cable are supplied.



5.3 Standard Platform

5.3.1 PLATE STANDARD IF-A1520 (R12NZ901PA)

This is the IF-A1520 standard platform. The IF-A1520 standard platform comprises an integral plate and plate frame.

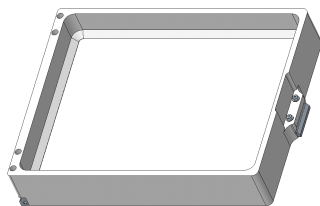

5.3.2 FRAME STANDARD IF-A2330 (R12NZ901P9)

This is the IF-A2330 plate frame. No plate is supplied.

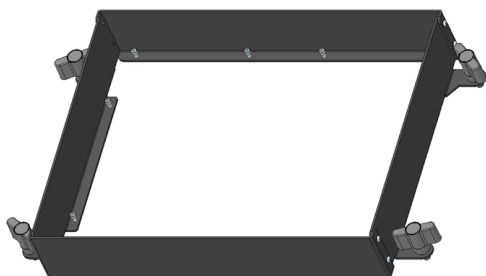

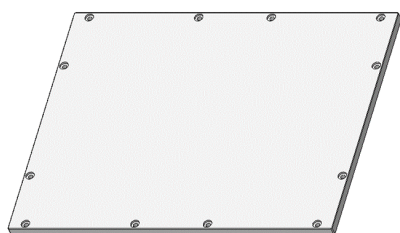

5.3.3 PLATE STANDARD IF-A2330 (R12NZ901PB)

This is the IF-A2330 standard plate. No plate frame or fixing screws are supplied.
The tightening torque for mounting to the plate frame is 1.2 N·m.

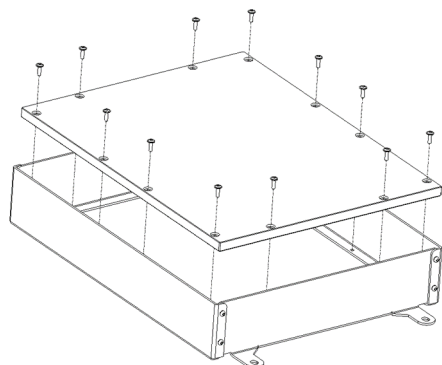

Installation diagram (Fixing screws are attached to the plate frame)



 **KEY POINTS**

Apply a drop of adhesive (such as Loctite 243) to the threads of the plate fixing screws before fastening. The adhesive is not supplied with the product.

5.4 Anti-rolling Plate

The anti-rolling plate has a machined surface to stabilize parts that tend to roll on the platform. The anti-rolling plate is especially useful when working with cylindrical parts, as it reduces the time for the part to stabilize.

(Unit: mm)

Surface of the anti-rolling plate

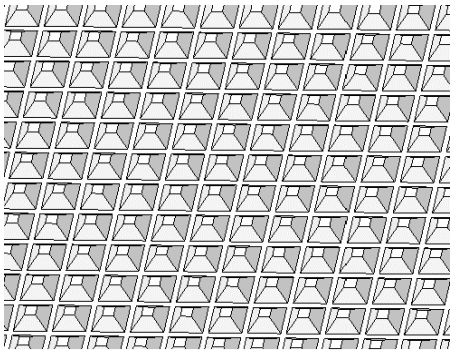

Surface machining dimensions of the anti-rolling plate

	a	b	c	d
IF-A1520	7	5	2	90°
IF-A2330	7	5	2	90°

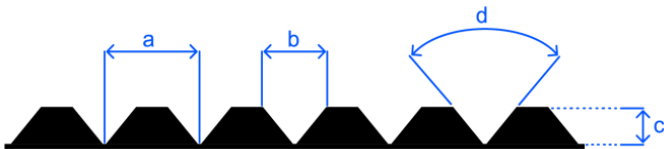

5.4.1 PLATE ANTI-ROLL IF-A1520 (R12NZ901PC)

This is the anti-roll specification platform for IF-A1520. The IF-A1520 anti-rolling platform comprises an integral plate and plate frame.

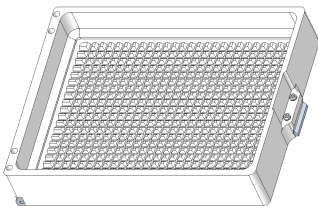

5.4.2 PLATE ANTI-ROLL IF-A2330 (R12NZ901PD)

This is the IF-A2330 anti-rolling plate. No plate frame or fixing screws are supplied.

The tightening torque for mounting to the plate frame is 1.2 N·m. The installation method is the same as for the standard plate. See below.

PLATE STANDARD IF-A2330 (R12NZ901PB)

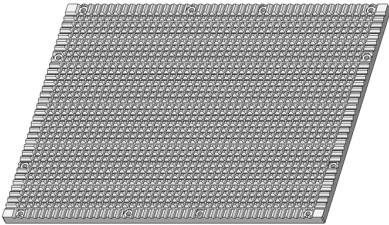

KEY POINTS

Apply a drop of adhesive (such as Loctite 243) to the threads of the plate fixing screws before fastening. The adhesive is not supplied with the product.

5.5 Purge Gate

To eject the parts from the platform, the standard platform can be changed to a platform with purge gate. Parts can be ejected from the long side of the platform, either to the right or left.

5.5.1 PURGE UNIT (L) IF-A1520 (R12NZ901PE)

This is the platform with purge gate set for the IF-A1520 (left side). Supplied with an actuator unit and a dedicated plate frame. No plate for the purge gate is supplied.

The ejection door is attached to the left side when facing the main unit interface. The ejection direction cannot be changed after purchase.

The installation method is described below.

Mounting the Purge Gate

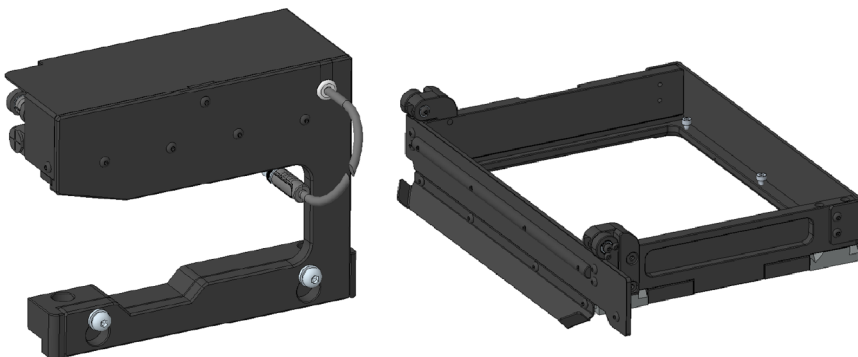

Reference: Image after installation

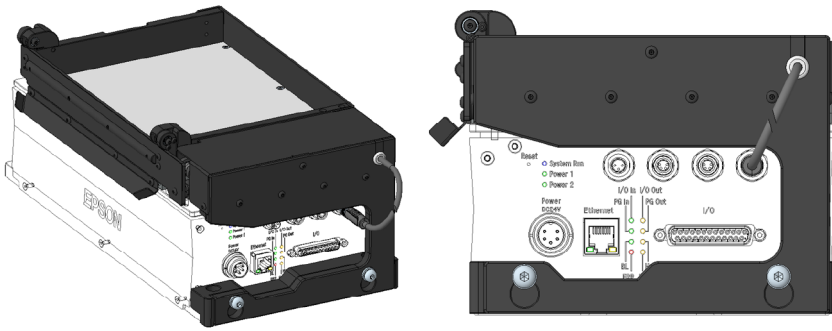

5.5.2 PURGE UNIT (R) IF-A1520 (R12NZ901PF)

This is the platform with purge gate set for the IF-A1520 (right side). Supplied with an actuator unit and a dedicated plate frame. No plate for the purge gate is supplied.

The ejection door is attached to the right side when facing the main unit interface. The ejection direction cannot be changed after purchase.

The installation method is described below.

Mounting the Purge Gate

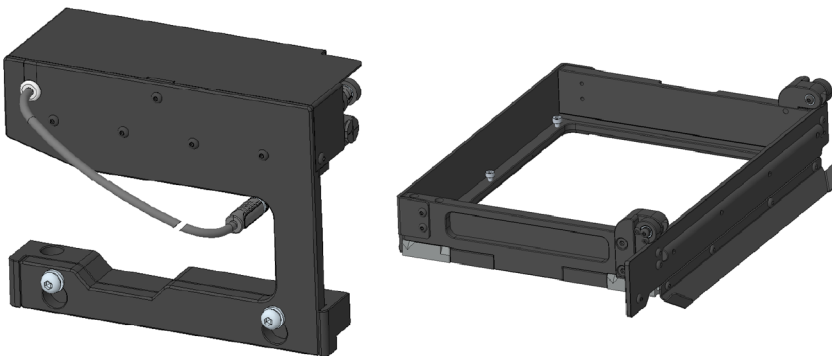

Reference: Image after installation

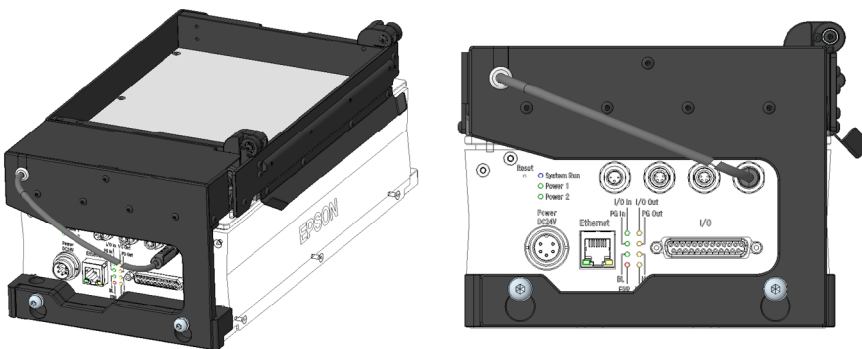

5.5.3 PLATE PURGE STANDARD IF-A1520 (R12NZ901PH)

This is the plate for the purge gate. No plate frame or fixing screws are supplied.

The tightening torque for mounting to the plate frame is 1.2 N·m.

The installation method is described below.

Mounting the Purge Gate

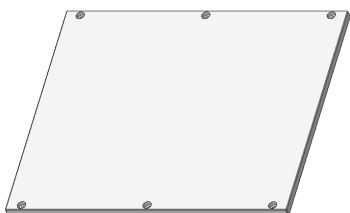

5.5.4 PURGE UNIT IF-A2330 (R12NZ901PK)

This is the platform set with purge gate for the IF-A2330. Supplied with an actuator unit, a dedicated plate frame, guide plate, and extension cable (a). No plate is supplied. The standard plates for IF-A2330 can be used. The same platform with purge gate for the IF-A2330 is used to eject parts to the left or right. The installation method is described below.

Mounting the Purge Gate

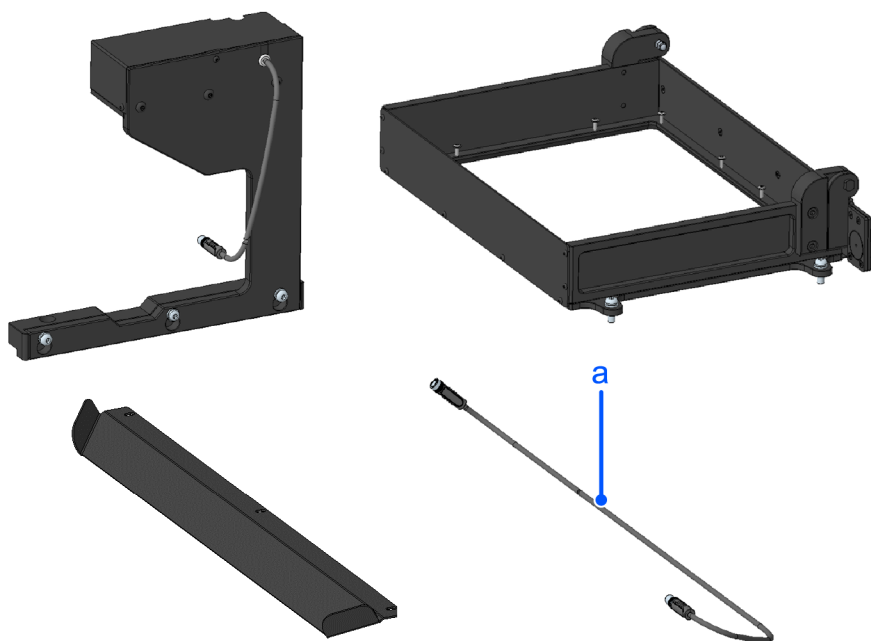

Reference: Image after installation

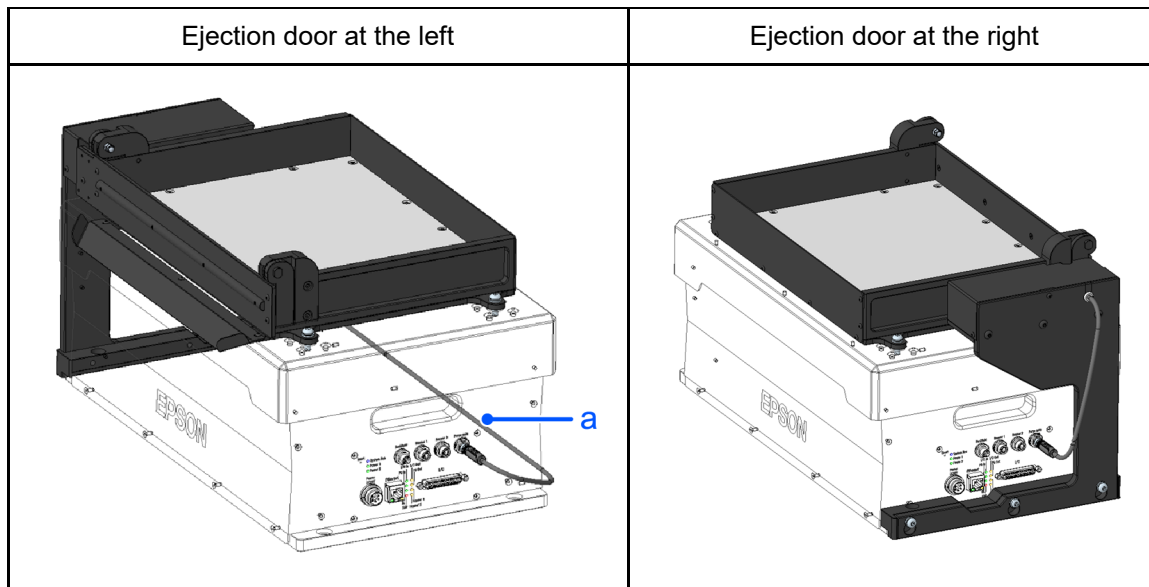

5.6 Hopper

The following hoppers can be connected to this product.

- Hopper (Gen.1)
- Hopper (Gen.2)

For the hopper model name and more details, refer to following manual.

- "Epson RC+ 8.0 Option Part Feeding 8.0 Hopper (Gen.1)"
- "Epson RC+ 8.0 Option Part Feeding 8.0 Hopper (Gen.2)"

6. Purge Gate

6.1 Purge Gates

The platform with purge gate is supplied with power and controlled directly from the flexible feeder main unit. For information on the purge gate settings and control, refer to the following manual.

"Epson RC+ 8.0 Option Part Feeding 8.0 Introduction & Software"

6.2 Purge Gate External Dimensions

(Unit: mm)

IF-A1520 (ejection door at left)

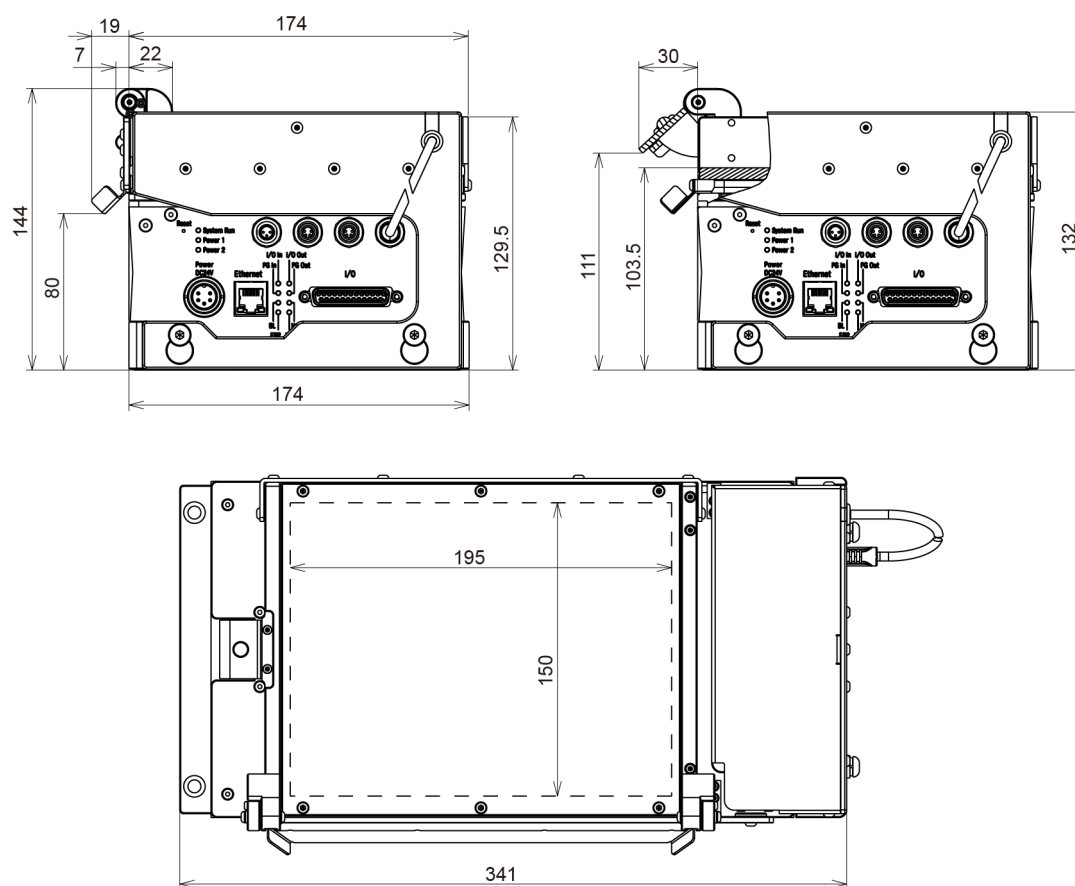

IF-A1520 (ejection door at right)

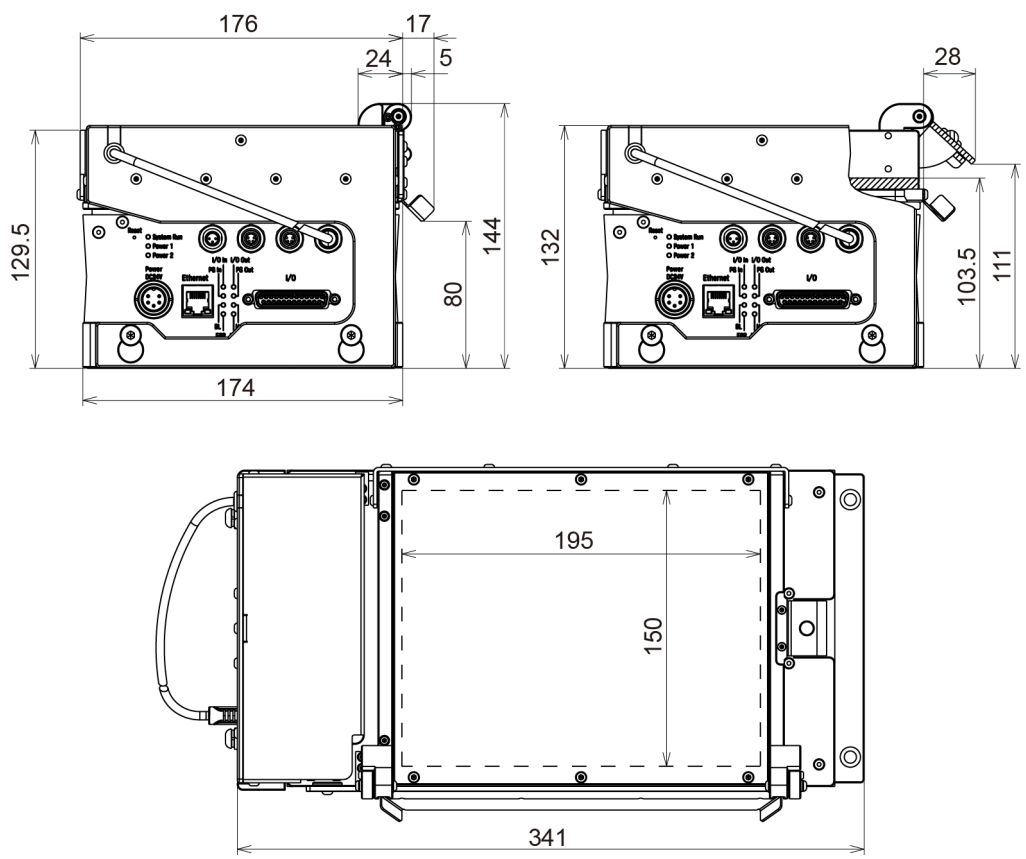

IF-A2330 (ejection door at left)

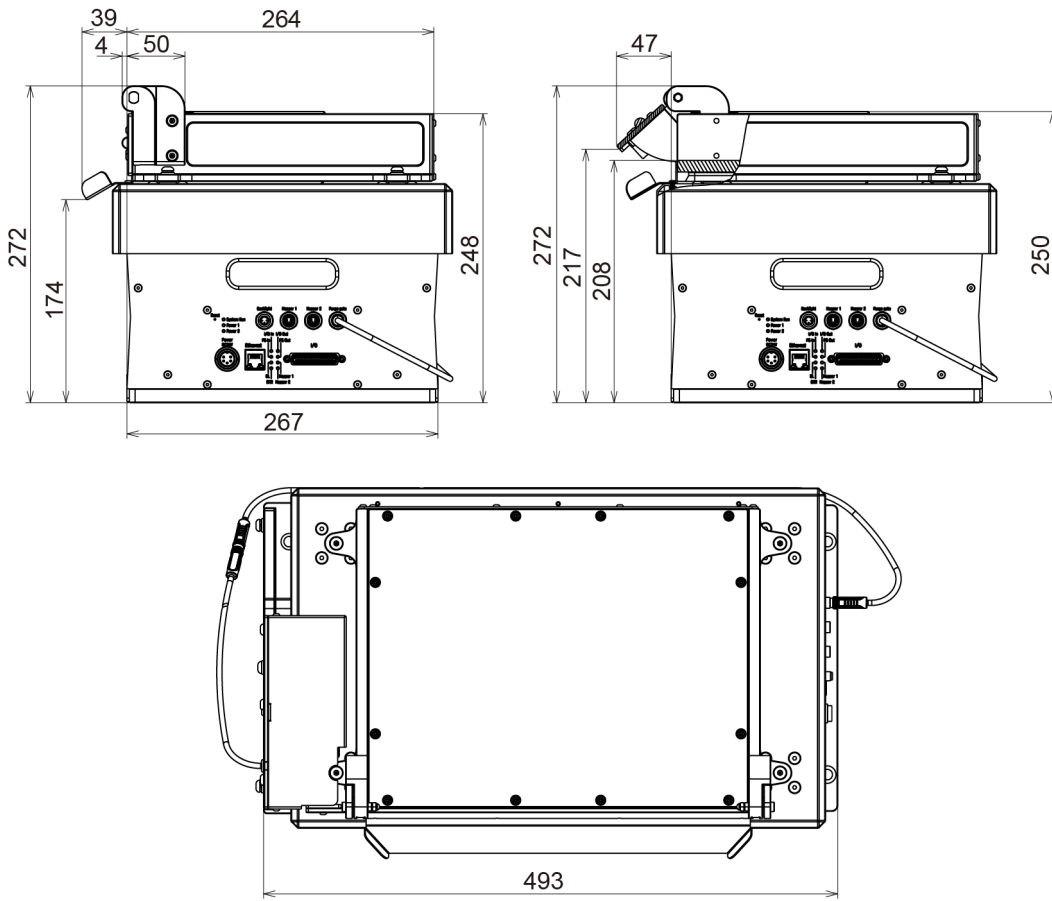

IF-A2330 (ejection door at right)

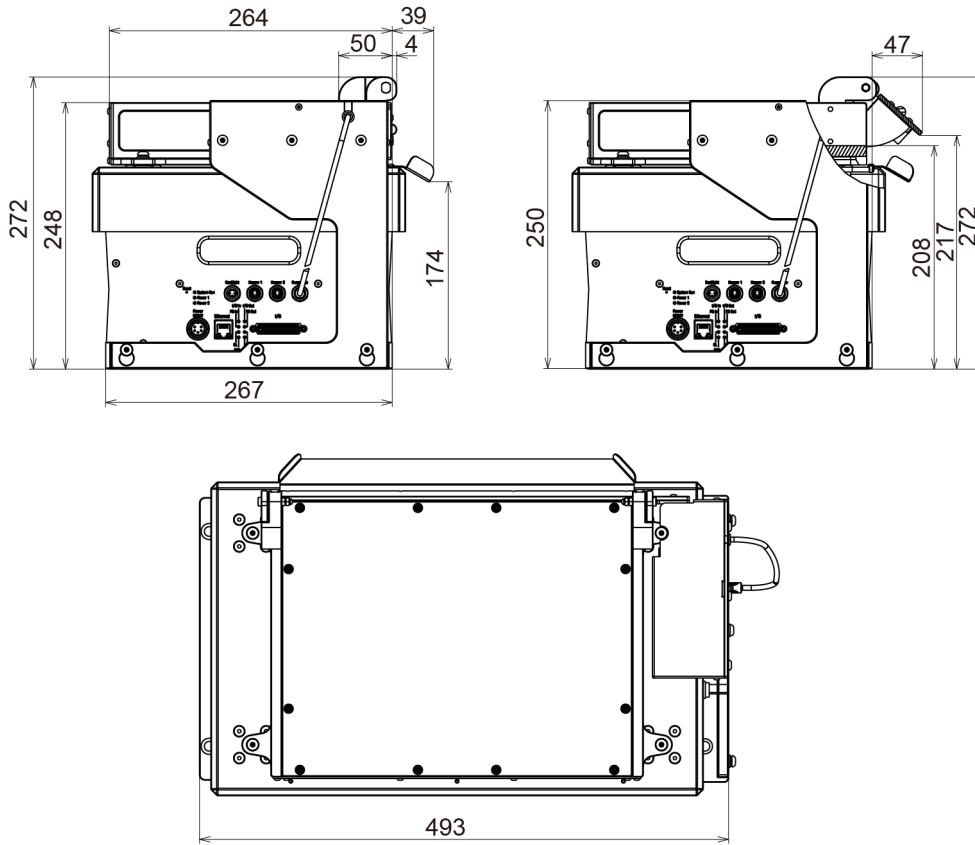

6.3 Mounting the Purge Gate

⚠ WARNING

Before installing the purge gate, make sure that all power cables and other cables are disconnected from the unit.

⚠ CAUTION

Wiring should be performed by a certified technician or qualified person. Wiring work by inexperienced persons may result in injury or breakdown. Also, be sure to install wiring in a way that will not cause people to trip or fall over it.

- 1. Mounting the plate in the plate frame**
Fix the plate (b) to the plate frame (a) using the included screws.
Tighten each screw to the specified tightening torque.

IF-A1520

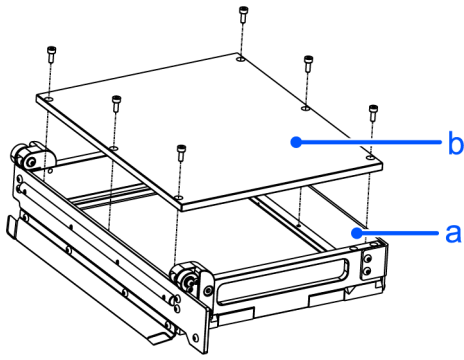

Mounting screw x 7

Tightening torque: 1.2 N·m

IF-A2330

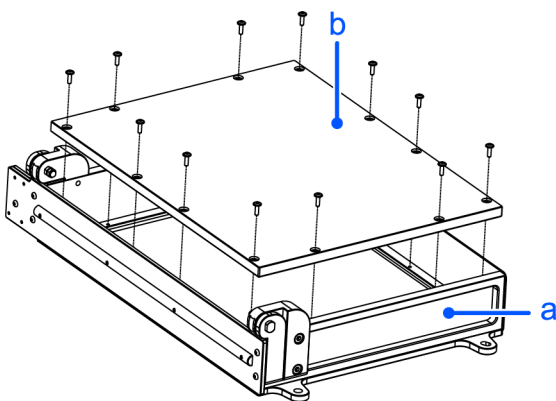

Mounting screw x 12

Tightening torque: 1.2 N·m

KEY POINTS

Apply a drop of adhesive (such as Loctite 243) to the threads of the plate fixing screws before fastening. The adhesive is not supplied with the product.

2. Mounting the actuator unit

KEY POINTS

Make sure to check the orientation of the roller on the tip of the actuator before attaching the actuator unit. If it is attached in the incorrect orientation, follow the procedure below to adjust it to the correct orientation:

1. Rotate the roller clockwise until it can no longer be rotated.
2. Rotate the roller counterclockwise to adjust it to the correct orientation.

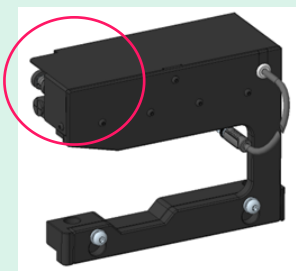

Correct orientation	Incorrect orientation

IF-A1520

The actuator unit installation method is the same for the left and right sides.

Step 1. Mounting the fixing brackets	Step 2. Mounting the actuator unit

IF-A2330

The actuator unit installation method is the same for the left and right sides.

The mounting position differs for the left and right sides. (Diagram shows the right side)

Step 1. Guide plate installation	Step 2. Mounting the fixing brackets	Step 3. Mounting the actuator unit

3. Mounting the platform

Follow the same guidelines as below to install the platform with purge gate.

Attaching/Removing Platform

KEY POINTS

For mounting the IF-A2330, use the screws provided with the plate frame for the purge gate. The standard handle screws cannot be used.

4. Wiring connections

IF-A1520

Connect the control cable that is fixed to the actuator unit to the purge gate interface of the main unit.

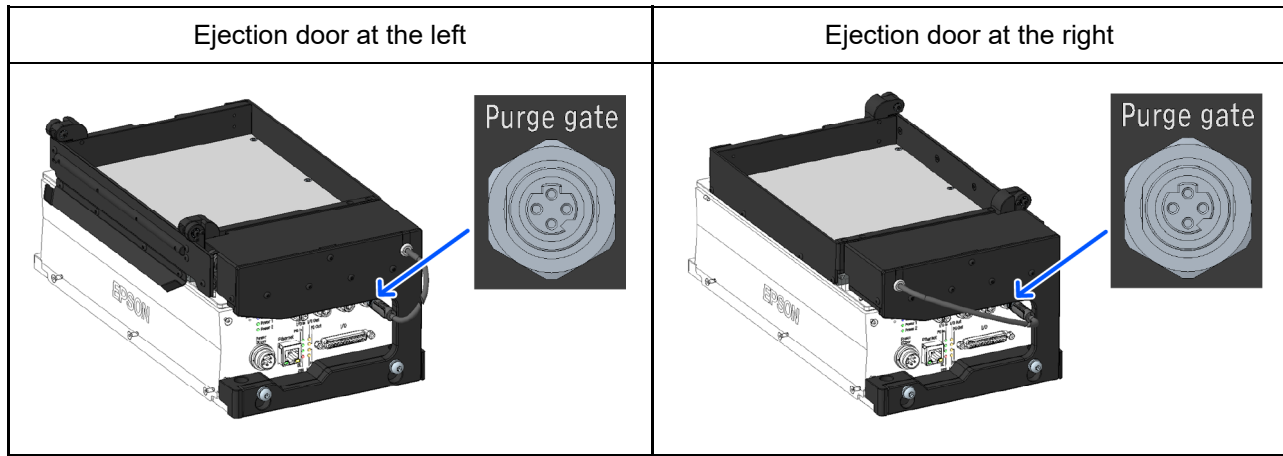

IF-A2330

For the right side, directly connect the control cable that is fixed to the actuator unit to the purge gate interface of the main unit. For the left side, connect the supplied extension cable to the control cable and connect it to the purge gate interface of the main unit.

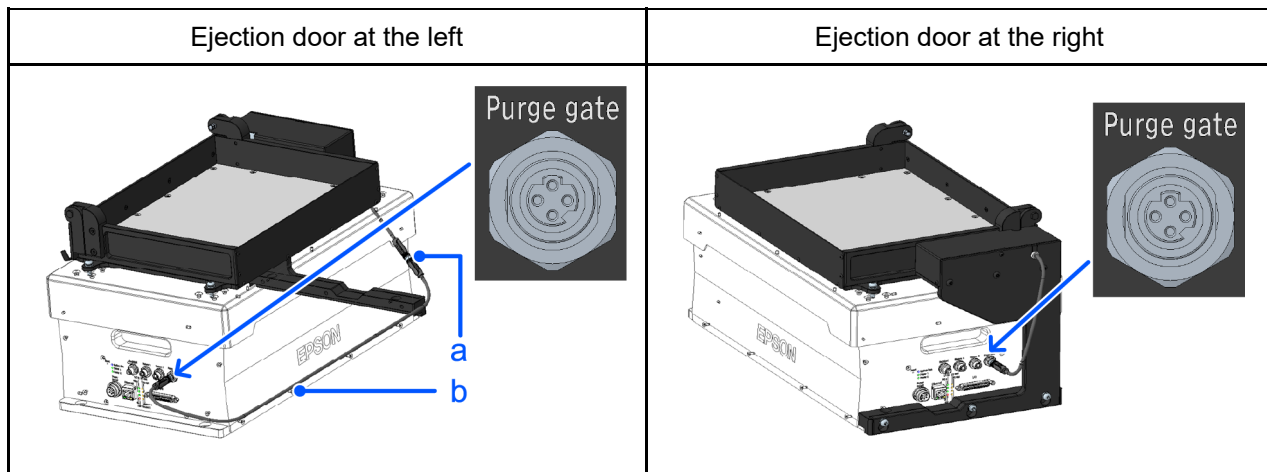









a: Connector/b: Extension cable

7. Customize the platform

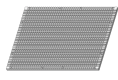
7.1 Platform Type

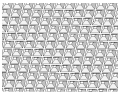
KEY POINTS
 The custom platform should be designed and made by the customer.

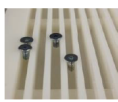
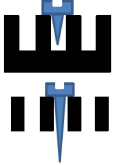
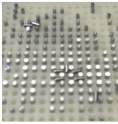
By structuring the surface of the plate, the availability of specific parts can be enhanced. A representative structure is shown in the table below. The custom platform should be designed and made by the customer.

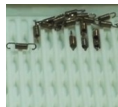
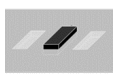
Platform Type	Example-picture	Example-drawing	Meaning
Flat			It can be used for a variety of parts, mainly parts with flat surfaces and stable stationary positions.
Anti-stick			Narrow grooves are effective for reducing contact resistance on flat, light parts, improving the movement of parts that are difficult to disperse due to friction.
Anti-roll			It is effective when stopping cylindrical parts that tend to roll.
Grooves			It is effective when stabilizing screw type parts in an upright position. When penetrating the groove to handle longer parts, an internal diffusing plate (*1) is needed to prevent the backlight from entering the camera through the hole. The internal diffusing plate is positioned on the backlight.
Holes			It is effective when stabilizing cylindrical type parts in an upright position.
Pockets			The dent that matches each part shape helps to stabilize the pose.

*1 Internal diffusing plate should be prepared by the customer.

7.2 Dimension of the platform

A reference diagram to design the custom platform is indicated.
 (Unit: mm)

7.2.1 IF-A1520

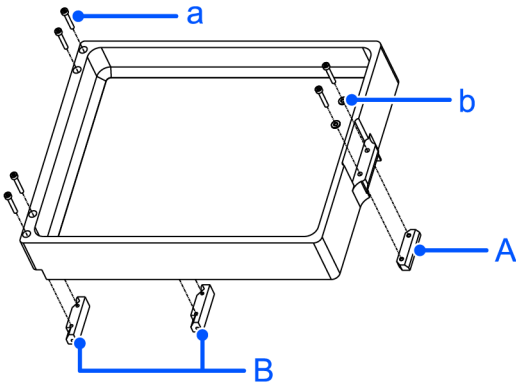

Symbols	Meaning
a	M2.5 × 16 (6 ×)
b	washers (2 ×)

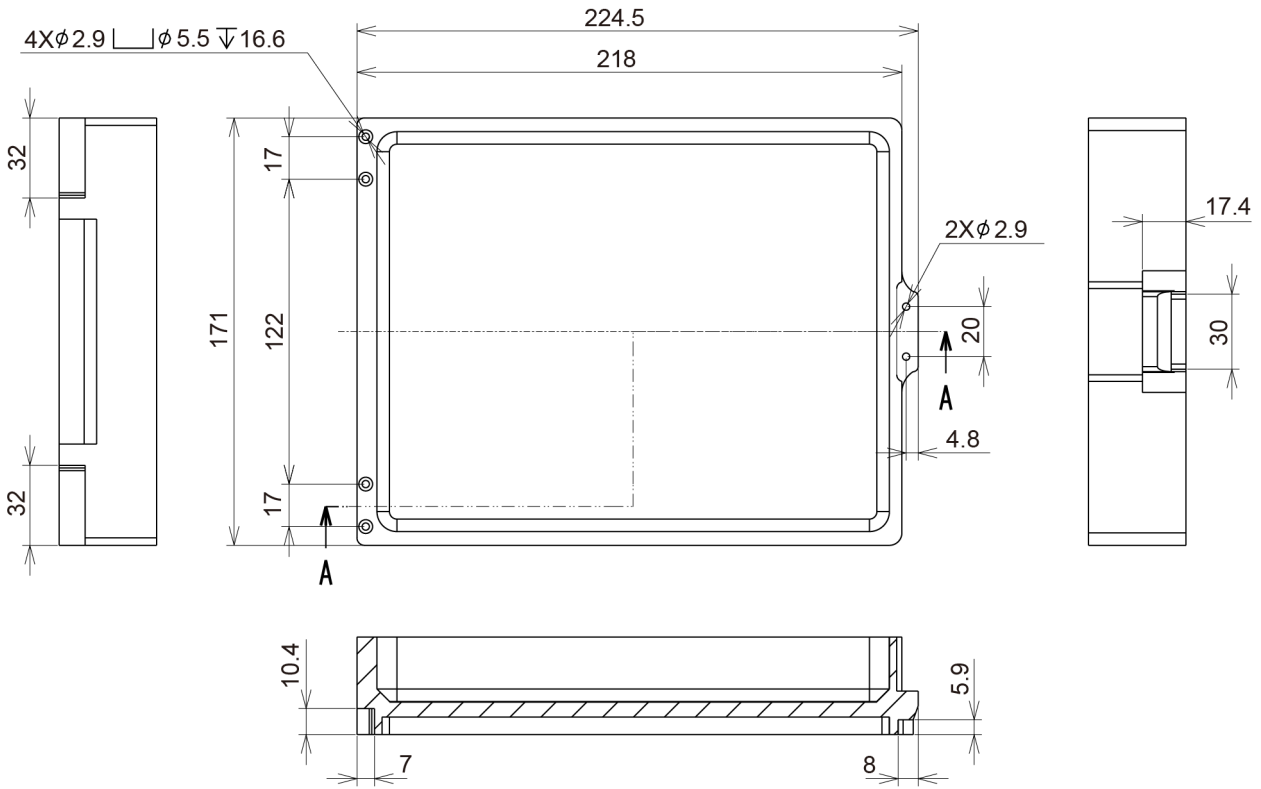

A - A

Part A

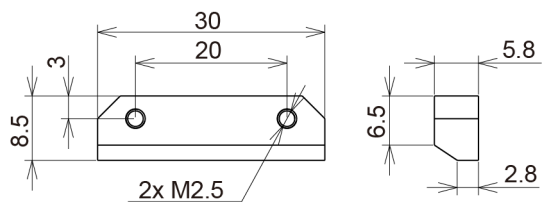

Part B

(2 ×)

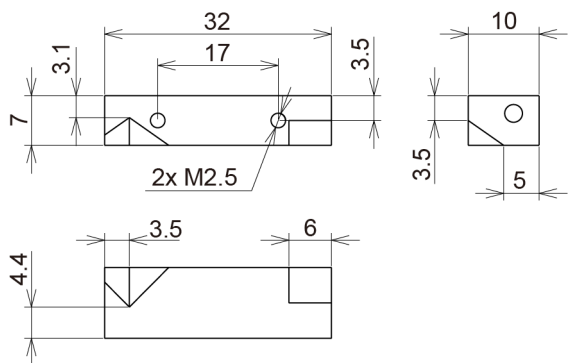

7.2.2 IF-A2330

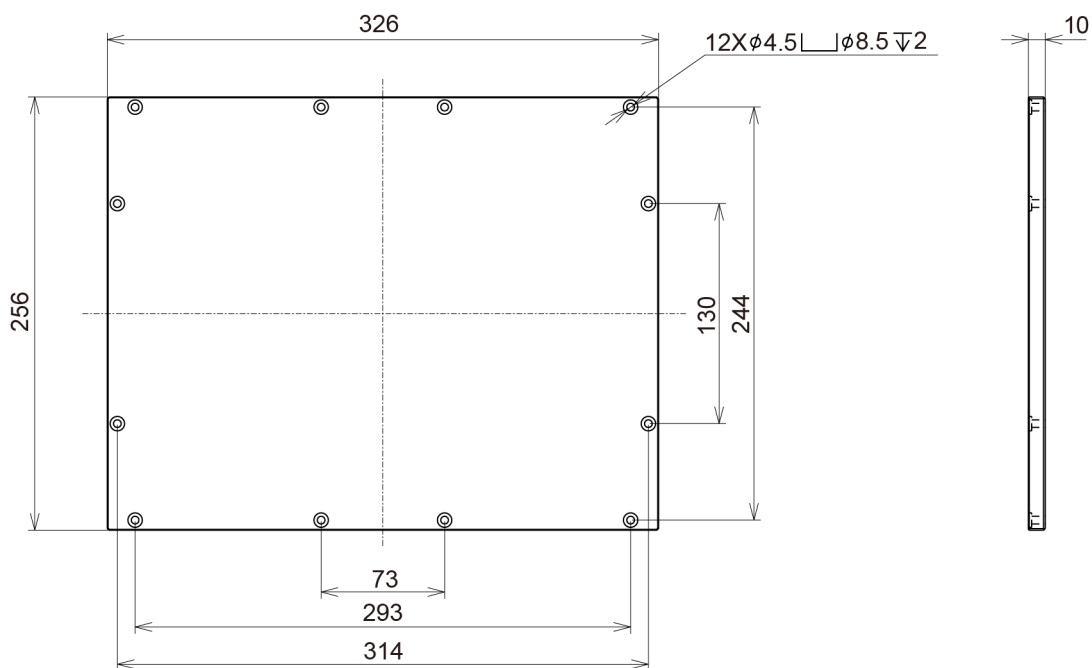

8. Maintenance and Component Replacement

8.1 Replacement Parts

KEY POINTS

There are no parts inside the product that can be replaced by the user. To request repair, consult your supplier.

The platform is a consumable part. If the plate surface becomes damaged or worn to the point of impeding the movement of parts or the vision system operation, the platform or the plate must be replaced.

For information about the replacement options, see below.

Options

8.2 Regular Maintenance

WARNING

Before performing maintenance on the product, make sure that all power cables and other cables are disconnected from the unit.

CAUTION

Make sure that the platform has been removed before performing maintenance.

Perform the following periodic inspections to keep the product functioning properly and safely.

Maintenance schedule

Item	Frequency	Reference
Inspecting the fixing screws	Monthly	See below. Mounting
Inspecting the backlight	Monthly	Perform a visual appearance check.
Cleaning the platform	Weekly	See below. Cleaning the Platform

KEY POINTS

The information in the maintenance schedule table is for information only. Maintenance and times must be modified in accordance with your particular system, its operating environment and the amount of usage.

8.3 Cleaning the Platform

KEY POINTS

Foreign matter or scratches on the plate surface may interfere with the movement of parts or the vision system. Therefore, check the condition of the platform and clean it regularly.

Items needed before cleaning

- Lint-free cloth
- Isopropanol alcohol

Procedure

1. Check the plate surface. Pay particular attention to the following points.
 - Scratches
 - Dirt or spots on the surface
 - Oil or grease having adhered to the surface
2. Clean the surface of the platform with ethanol and a rag.

9. Troubleshooting

9.1 Troubleshooting

For information on troubleshooting, refer to the following:

"Epson RC+ 8.0 Option Part Feeding 8.0 Introduction & Software - Troubleshooting"