

EPSON

Industrial Robot: 6-Axis Robots C-B series Manual

Original instructions

© Seiko Epson Corporation 2024

Rev.3
ENM247R6560F

Table of Contents

1. Introduction	10
1.1 Introduction	11
1.2 Trademarks	11
1.3 Terms of Use	11
1.4 Manufacturer	11
1.5 Contact Information	11
1.6 Disposal	12
1.7 Before Use	12
1.8 Manual Types for This Product	12
2. C4 Manipulator	14
2.1 Safety	15
2.1.1 Conventions Used in This Manual	15
2.1.2 Design and Installation Safety	15
2.1.3 Operation Safety	16
2.1.4 Emergency Stop	17
2.1.5 Safeguard (SG)	17
2.1.6 How to Move Arms with the Electromagnetic Brake	18
2.1.6.1 When using a brake release unit	19
2.1.6.2 When using software	19
2.1.7 Precaution for Operation in Low Power Status	20
2.1.8 Warning Labels	20
2.1.8.1 Warning Labels	20
2.1.8.2 Information Labels	21
2.1.9 Responses for Emergencies or Malfunctions	22
2.1.9.1 When a Collision with the Manipulator Occurs	22
2.1.9.2 Entanglement with the Manipulator	22
2.2 Specifications	22
2.2.1 Model Number	22
2.2.2 Part Names and Motion Range of Each Arm	23
2.2.3 Outer Dimensions	25
2.2.3.1 C4-B601**	25
2.2.3.2 C4-B901**	26

2.2.4 Standard Work Envelope	27
2.2.4.1 C4-B601**	27
2.2.4.2 C4-B901**	28
2.2.5 Specifications	30
2.2.5.1 Specifications Table	30
2.2.5.2 Options	30
2.2.6 How to Set the Model	30
2.3 Environment and Installation	30
2.3.1 Environment	31
2.3.2 Manipulator Mounting Dimensions	32
2.3.3 From Unpacking to Installation	34
2.3.4 Connecting the Cables	38
2.3.5 User Wires and Pneumatic Tubes	39
2.3.6 Checking the Basic Orientation	40
2.3.7 Relocation and Storage	41
2.3.7.1 Safety Information for Relocation and Storage	41
2.4 Setting the Hand	45
2.4.1 Installing the Hand	45
2.4.2 Attaching Cameras and Valves	47
2.4.3 WEIGHT and INERTIA Settings	48
2.4.3.1 WEIGHT Setting	51
2.4.3.2 INERTIA Setting	55
2.4.4 Safety Information for Auto Acceleration	59
2.5 Work Envelope	60
2.5.1 Work Envelope Setting by Pulse Range (for Each Joint)	60
2.5.1.1 Arm #1 Maximum Pulse Range	61
2.5.1.2 Arm #2 Maximum Pulse Range	63
2.5.1.3 Arm #3 Maximum Pulse Range	64
2.5.1.4 Arm #4 Maximum Pulse Range	64
2.5.1.5 Arm #5 Maximum Pulse Range	65
2.5.1.6 Arm #6 Maximum Pulse Range	66
2.5.2 Setting the Work Envelope by Mechanical Stops	67
2.5.2.1 Setting the Arm #1 Work Envelope	67
2.5.2.2 Setting the Arm #2 Work Envelope	68
2.5.2.3 Setting the Arm #3 Work Envelope	69

2.5.3 Restriction of Manipulator Operation by Joint Angle Combination	69
2.5.4 Coordinate System	71
2.5.5 Changing the Robot	72
2.5.6 Setting the Rectangular Range in the XY Coordinate System of the Manipulator	74
2.6 Options	74
2.6.1 Brake Release Unit	74
2.6.1.1 Power Cable	75
2.6.1.2 Installing the Brake Release Unit	77
2.6.1.3 Removing the Brake Release Unit	77
2.6.1.4 How to Use the Brake Release Unit	78
2.6.2 Camera Plate Unit	78
2.6.3 PS Compatible Plate (Tool Adapter)	82
2.6.4 Base Side Angled Fittings	84
2.6.5 Base Side Fittings	87
2.6.6 PS Compatible Plate (Base Adapter)	91
2.6.7 Variable Mechanical Stop	92
3. C8 Manipulator	94
3.1 Safety	95
3.1.1 Conventions Used in This Manual	95
3.1.2 Design and Installation Safety	95
3.1.3 Operation Safety	96
3.1.4 Emergency Stop	97
3.1.5 Safeguard (SG)	97
3.1.6 How to Move Arms with the Electromagnetic Brake	98
3.1.6.1 When using a brake release unit	99
3.1.6.2 When using software	99
3.1.7 Precaution for Operation in Low Power Status	100
3.1.8 Warning Labels	100
3.1.8.1 Warning Labels	100
3.1.8.2 Information Labels	101
3.1.9 Responses for Emergencies or Malfunctions	102
3.1.9.1 When a Collision with the Manipulator Occurs	102
3.1.9.2 Entanglement with the Manipulator	102
3.2 Specifications	102
3.2.1 Model Number	102

3.2.2 Part Names and Motion Range of Each Arm	104
3.2.3 Outer Dimensions	106
3.2.3.1 C8-B901*** (C8L)	106
3.2.3.2 C8-B1401*** (C8L)	107
3.2.4 Standard Work Envelope	108
3.2.4.1 C8-B901*** (C8L)	108
3.2.4.2 C8-B1401*** (C8XL)	111
3.2.5 Specifications	112
3.2.5.1 Specifications Table	112
3.2.5.2 Options	112
3.2.6 How to Set the Model	112
3.3 Environment and Installation	112
3.3.1 Environment	113
3.3.2 Manipulator Mounting Dimensions	114
3.3.2.1 Cable backward model	115
3.3.2.2 Cable downward model	116
3.3.3 From Unpacking to Installation	118
3.3.4 Connecting the Cables	122
3.3.5 User Wires and Pneumatic Tubes	123
3.3.5.1 Electrical Wires	124
3.3.5.2 Pneumatic Tubes	125
3.3.6 Checking the Basic Orientation	126
3.3.7 Relocation and Storage	126
3.3.7.1 Safety Information for Relocation and Storage	127
3.4 Setting the Hand	129
3.4.1 Installing the Hand	129
3.4.2 Attaching Cameras and Valves	131
3.4.3 WEIGHT and INERTIA Settings	132
3.4.3.1 WEIGHT Setting	135
3.4.3.2 INERTIA Setting	138
3.4.4 Safety Information for Auto Acceleration	141
3.5 Work Envelope	142
3.5.1 Work Envelope Setting by Pulse Range (for Each Joint)	142
3.5.1.1 Joint #1 Maximum Pulse Range	143
3.5.1.2 Joint #2 Maximum Pulse Range	143

3.5.1.3 Joint #3 Maximum Pulse Range	144
3.5.1.4 Joint #4 Maximum Pulse Range	144
3.5.1.5 Joint #5 Maximum Pulse Range	144
3.5.1.6 Joint #6 Maximum Pulse Range	145
3.5.2 Setting the Work Envelope by Mechanical Stops	145
3.5.2.1 Setting the Joint #1 Work Envelope	146
3.5.2.2 Setting the Joint #2 Work Envelope	146
3.5.2.3 Setting the Joint #3 Work Envelope	147
3.5.3 Restriction of Manipulator Operation by Joint Angle Combination	148
3.5.4 Coordinate System	149
3.5.5 Changing the Robot	151
3.5.6 Setting the Rectangular Range in the XY Coordinate System of the Manipulator	152
3.6 Options	152
3.6.1 Brake Release Unit	152
3.6.1.1 Power Cable	154
3.6.1.2 Installing the Brake Release Unit	155
3.6.1.3 Removing the Brake Release Unit	156
3.6.1.4 How to Use the Brake Release Unit	156
3.6.2 Camera Plate Unit	157
3.6.3 Tool Adapter (ISO flange)	159
3.6.4 Variable Mechanical Stop	161
3.6.5 User Wires and Pneumatic Tubes	162
4. C12 Manipulator	163
4.1 Safety	164
4.1.1 Conventions Used in This Manual	164
4.1.2 Design and Installation Safety	164
4.1.3 Operation Safety	165
4.1.4 Emergency Stop	166
4.1.5 Safeguard (SG)	166
4.1.6 How to Move Arms with the Electromagnetic Brake	167
4.1.6.1 When using a brake release unit	168
4.1.6.2 When using software	168
4.1.7 Precaution for Operation in Low Power Status	169
4.1.8 Warning Labels	169
4.1.8.1 Warning Labels	169

4.1.8.2 Information Labels	170
4.1.9 Responses for Emergencies or Malfunctions	171
4.1.9.1 When a Collision with the Manipulator Occurs	171
4.1.9.2 Entanglement with the Manipulator	171
4.2 Specifications	171
4.2.1 Model Number	171
4.2.2 Part Names and Motion Range of Each Arm	172
4.2.3 Outer Dimensions	175
4.2.4 Standard Work Envelope	176
4.2.5 Specifications	177
4.2.5.1 Specifications Table	177
4.2.5.2 Options	177
4.2.6 How to Set the Model	177
4.3 Environment and Installation	177
4.3.1 Environment	178
4.3.2 Manipulator Mounting Dimensions	179
4.3.2.1 Cable backward model	179
4.3.2.2 Cable downward model	180
4.3.3 From Unpacking to Installation	181
4.3.4 Connecting the Cables	185
4.3.5 User Wires and Pneumatic Tubes	186
4.3.5.1 Electrical Wires	187
4.3.5.2 Pneumatic Tubes	188
4.3.6 Checking the Basic Orientation	188
4.3.7 Relocation and Storage	189
4.3.7.1 Safety Information for Relocation and Storage	189
4.4 Setting the Hand	191
4.4.1 Installing the Hand	191
4.4.2 Attaching Cameras and Valves	193
4.4.3 WEIGHT and INERTIA Settings	193
4.4.3.1 WEIGHT Setting	196
4.4.3.2 INERTIA Setting	198
4.4.4 Safety Information for Auto Acceleration	202

4.5 Work Envelope	203
4.5.1 Work Envelope Setting by Pulse Range (for Each Joint)	203
4.5.1.1 Joint #1 Maximum Pulse Range	204
4.5.1.2 Joint #2 Maximum Pulse Range	204
4.5.1.3 Joint #3 Maximum Pulse Range	204
4.5.1.4 Joint #4 Maximum Pulse Range	205
4.5.1.5 Joint #5 Maximum Pulse Range	205
4.5.1.6 Joint #6 Maximum Pulse Range	205
4.5.2 Setting the Work Envelope by Mechanical Stops	206
4.5.2.1 Setting the Joint #1 Work Envelope	206
4.5.2.2 Setting the Joint #2 Work Envelope	207
4.5.2.3 Setting the Joint #3 Work Envelope	207
4.5.3 Restriction of Manipulator Operation by Joint Angle Combination	208
4.5.4 Coordinate System	208
4.5.5 Changing the Robot	209
4.5.6 Setting the Rectangular Range in the XY Coordinate System of the Manipulator	210
4.6 Options	210
4.6.1 Brake Release Unit	211
4.6.1.1 Power Cable	212
4.6.1.2 Installing the Brake Release Unit	213
4.6.1.3 Removing the Brake Release Unit	214
4.6.1.4 How to Use the Brake Release Unit	214
4.6.2 Camera Plate Unit	215
4.6.3 Tool Adapter (ISO flange)	217
4.6.4 Variable Mechanical Stop	219
4.6.5 User Wires and Pneumatic Tubes	220
5. Periodic Inspection	221
5.1 C4 Manipulator Periodic Inspection	222
5.1.1 Inspection	222
5.1.1.1 Inspection Schedule	222
5.1.1.2 Inspection Details	223
5.1.2 Overhaul (Parts Replacement)	224
5.1.3 Applying Grease	224
5.1.4 Tightening the Hexagon Socket Head Cap Bolts	225

5.2 C8 Manipulator Periodic Inspection	226
5.2.1 Inspection	226
5.2.1.1 Inspection Schedule	226
5.2.1.2 Inspection Details	227
5.2.2 Overhaul (Parts Replacement)	228
5.2.3 Applying Grease	229
5.2.4 Tightening the Hexagon Socket Head Cap Bolts	229
5.3 C12 Manipulator Periodic Inspection	230
5.3.1 Inspection	230
5.3.1.1 Inspection Schedule	230
5.3.1.2 Inspection Details	231
5.3.2 Overhaul (Parts Replacement)	233
5.3.3 Applying Grease	233
5.3.4 Tightening the Hexagon Socket Head Cap Bolts	234
6. Appendix	235
6.1 Appendix A: Specifications Table	236
6.1.1 C4 Specifications	236
6.1.2 C8 Specifications	241
6.1.3 C12 Specifications	247
6.2 Appendix B: Stopping Time and Stopping Distance at Emergency Stop	252
6.2.1 C4-B Stopping Time and Stopping Distance at Emergency Stop	253
6.2.2 C8-B Stopping Time and Stopping Distance at Emergency Stop	256
6.2.3 C12-B Stopping Time and Stopping Distance at Emergency Stop	263
6.3 Appendix C: Stopping Time and Stopping Distance When Safeguard is Open	265
6.3.1 C4-B Stopping Time and Stopping Distance When Safeguard is Open	266
6.3.2 C8-B Stopping Time and Stopping Distance When Safeguard is Open	270
6.3.3 C12-B Stopping Time and Stopping Distance When Safeguard is Open	277

1. Introduction

1.1 Introduction

Thank you for purchasing this Epson robot system. This manual provides the information necessary for correctly using the robot system.

Before using the system, please read this manual and related manuals to ensure correct use.

After reading this manual, store it in an easily accessible location for future reference.

Epson conducts rigorous testing and inspection to ensure that the performance of our robot systems meets our standards. Please note that if the Epson robot system is used outside the operating conditions described in the manual, the product will not perform up to its basic performance.

This manual describes potential hazards and problems that are foreseen. To use the Epson robot system safely and correctly, be sure to follow the safety information contained in this manual.

1.2 Trademarks

Microsoft, Windows, and the Windows logo are either registered trademarks or trademarks of Microsoft Corporation in the United States and/or other countries. All other company names, brand names, and product names are registered trademarks or trademarks of their respective companies.

1.3 Terms of Use

No part of this instruction manual may be reproduced or reprinted in any form without express written permission.

The information in this document is subject to change without notice.

Please contact us if you find any errors in this document or if you have any questions about the information in this document.

1.4 Manufacturer

SEIKO EPSON CORPORATION

1.5 Contact Information

Contact information details are listed in the "Supplier" section in the following manual.

Note that the contact information may vary depending on your region.

"Safety Manual - Contact Information"

The Safety Manual is also available at the following site.

URL: <https://download.epson.biz/robots/>



1.6 Disposal

When disposing of this product, please do so in accordance with the laws and regulations of your country.

1.7 Before Use

Before using this manual, be sure that you understand the following information.

Control system configuration

The C-B series Manipulators are made up of a combination of the following Controller and software.

Manipulator	Controller	Software
C-B series	RC700-E	EPSON RC+ 7.0 Ver.7.5.4C or later Epson RC+ 8.0

Setting from the software

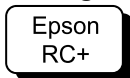

This manual contains the procedures for configuring the settings from the software. Use of this software is indicated by the above mark.

Controller power on (off)

In this manual, an instruction to "Turn on (off) the Controller power" means to turn on the power for the hardware that makes up your Controller.

Images used in this manual

The photos and illustrations of the Manipulators shown in this manual may differ in shape and appearance from your Manipulator due to the time it was shipped, specifications, and other factors.

1.8 Manual Types for This Product

This describes the typical types of manuals for this product and presents an overview of their content.

▪ Safety Manual (booklet, PDF manual)

This manual contains safety-related information intended for all people who use this product. It also guides the user through the process from unpacking to usage and the manuals that should be referred to next. Please read this manual first.

- Safety information and residual risks of robot systems
- Declaration of Conformity
- Training
- Process from unpacking to usage

▪ Robot Controller Safety Function Manual (PDF manual)

This describes the procedures for configuring the safety functions of this product and the configuration software. It is primarily intended for those who design robot systems.

▪ RC700-E Manual (PDF manual)

This manual describes the installation of the entire robot system and explains the specifications and functions of the Controller. It is primarily intended for those who design robot systems.

- Robot system installation procedure (specific details on the process from unpacking to usage)
- Controller daily inspection points

- Controller specifications and basic functions
- **C-B series Manual (PDF manual)**

This manual describes the specifications and functions of the Manipulator. It is primarily intended for those who design robot systems.

 - Manipulator installation, technical information needed for design, function and specification tables, etc.
 - Manipulator daily inspection points
- **Status Code/Error Code List (PDF manual)**

This provides the code numbers displayed on the Controller and messages displayed in the message area of the software. It is primarily intended for those who design and program robot systems.
- **Epson RC+ User's Guide (PDF manual)**

This manual presents an overview of the program development software.
- **Epson RC+ SPEL+ Language Reference (PDF manual)**

This manual explains the robot programming language SPEL+.

Other manuals (PDF manuals)

Manuals are available for each option.

Maintenance and servicing manuals

Manuals for maintenance and servicing are not included with the product. Maintenance should be performed by people who have received maintenance training provided by Epson and the suppliers. For more information, please contact the supplier.

2. C4 Manipulator

This chapter contains information for setup and operation of the Manipulators.

Please read this chapter thoroughly before setting up and operating the Manipulators.

2.1 Safety

The Manipulator and its related equipment should be unpacked and transported by people who have received installation training provided by Epson and the suppliers. Also, the laws and regulations of the installation country must be followed.

Before use, please read this manual and other related manuals to ensure correct use. After reading this manual, store it in an easily accessible location for future reference.

This product is intended for transporting and assembling parts in a safely isolated area.

2.1.1 Conventions Used in This Manual

The following symbols are used in this manual to indicate important safety information. Be sure to read the descriptions shown with each symbol.

WARNING

This symbol indicates an imminently hazardous situation which, if operation is not performed properly, will result in death or serious injury.

WARNING

This symbol indicates a potentially hazardous situation which, if operation is not performed properly, could result in an injury due to electric shock.

CAUTION

This symbol indicates a potentially hazardous situation which, if operation is not performed properly, may result in a minor or moderate injury or in property damage only.

2.1.2 Design and Installation Safety

The robot system should be designed and installed by people who have received installation training provided by Epson and the suppliers.

Design personnel should refer to the following manuals:

- "Safety Manual"
- "Controller Manual"
- "Manipulator Manual"

Refer to the following section for the installation safety information.

[Environment and Installation](#)

Be sure to read this section and follow the safety information before installation to ensure that the installation work is performed safely.

2.1.3 Operation Safety

The following items are safety precautions for operating personnel:

WARNING

- Be sure to read the Safety Manual before use. Operating the robot system without understanding the safety information can be extremely dangerous and may result in serious injury or severe equipment damage.
- Before operating the robot system, make sure that no one is inside the safety barriers. The robot system can be operated in the teaching operation mode even when someone is inside the safety barriers. Even though the motion of the Manipulator is always restricted (low speed and low power) to ensure operator safety, an unexpected movement by the Manipulator can be extremely dangerous and may cause serious safety problems.
- If the Manipulator moves abnormally during operation of the robot system, immediately press the emergency stop switch.

WARNING

- To perform the power supply lockout, remove the power plug. Be sure to connect the AC power cable to a power outlet. Do not connect it directly to a factory power source.
- Before performing any replacement work, inform others in the area that you are working, and then turn off the Controller and related equipment, and unplug the power cable from the power source. Performing any work procedure with the power turned on is extremely dangerous and may result in electric shock and/or malfunction of the robot system.
- Do not connect or disconnect the connector of the M/C cable while the Controller is turned on. There is a risk the Manipulator may malfunction, which is extremely hazardous. Also, performing any work procedure with the power turned on may result in electric shock and/or malfunction of the robot system.

CAUTION

- Whenever possible, only one person should operate the robot system. If it is necessary to operate with more than one person, ensure that all personnel communicate with each other and take all necessary safety precautions.
- If the Manipulator is operated repeatedly with each joint having an operating angle of 5° or less, the bearings used in the joints are likely to cause oil film shortage. Repeated operation may cause premature damage. To prevent premature damage, operate the Manipulator to move each joint to an angle of 30° or more about once per hour.
- When the robot is operating at low speed (Speed: 5 to 20%), vibration (resonance) may occur continuously during operation depending on the combination of the arm orientation and hand load. Vibration occurs due to the natural vibration frequency of the arm and can be reduced by taking the following measures:
 - Changing the robot speed
 - Changing the teach points
 - Changing the hand load

2.1.4 Emergency Stop

Each robot system needs equipment that will allow the operator to immediately stop the system's operation. Install an emergency stop device by using emergency stop input from the Controller or other equipment.

Before using the emergency stop switch, be aware of the following points.

- The emergency stop switch should be used to stop the Manipulator only in case of emergencies.
- Besides pressing the emergency stop switch when an emergency occurs, to stop the Manipulator during program operation, use the Pause or STOP (program stop) statements assigned to a standard I/O.
The Pause and STOP statements do not turn off motor energization, and so the brake is not locked.

To place the robot system in emergency stop mode in a non-emergency (normal) situation, press the emergency stop switch while the Manipulator is not operating.

Do not press the emergency stop switch unnecessarily while the Manipulator is operating normally.

It could shorten the lifespan of the following components.

- Brakes
The brakes will be locked, which will shorten the lifespan of the brakes due to worn brake friction plates.
 - Normal brake lifespan:
About 2 years (when the brakes are used 100 times/day)
or about 20,000 times
- Reduction gears
An emergency stop applies an impact to the reduction gear, which can shorten its life.

If the Manipulator is stopped by turning off the Controller while it is operating, the following problems may occur.

- Reduced life and damage to reduction gear
- Position shift at the joints

If a power outage or other unavoidable Controller power-off occurs during Manipulator operation, check the following points after power is restored.

- Damage in reduction gear
- Shifting of the joints from their proper positions

If there was any shifting, maintenance is required. For more information, please contact the supplier.

Stopping distance of emergency stop

The Manipulator during operation cannot stop immediately after the emergency stop switch is pressed. Also, the stopping time and movement distance vary depending on the following factors.

- Hand weight, WEIGHT setting, ACCEL setting, workpiece weight, SPEED setting, movement posture, etc.

For the stopping time and movement distance of the Manipulator, refer to the following section.

[Appendix B: Stopping Time and Stopping Distance at Emergency Stop](#)

2.1.5 Safeguard (SG)

To maintain a safe working zone, safety barriers must be set up around the Manipulator, and safeguards must be installed at the entrance and exit of the safety barriers.

The term "safeguard" as used in this manual refers to a safety device with an interlock that allows entry into the safety barriers. Specifically, this includes safety door switches, safety barriers, light curtains, safety gates, safety floor mats, and so on. The safeguard is an input that informs the Robot Controller that an operator may be inside the safeguard area. You must assign at least one Safeguard (SG) in Safety Function Manager.

When the safeguard is opened, Protective Stop operates to change to the safeguard open state (display: SO).

- **Safeguard open**
Operations are prohibited. Further robot operation is not possible until either the safeguard is closed, the latched state is released, and a command is executed, or the TEACH or TEST operation mode is turned on and the enable circuit is activated.
- **Safeguard closed**
The robot can operate automatically in an unrestricted (high power) state.

WARNING

- If a third party accidentally releases the safeguard while an operator is working inside the safety barriers, this may result in a hazardous situation. To protect the operator working inside the safety barriers, implement measures to lock out or tag out the latch release switch.
- To protect operators working near the robot, be sure to connect a safeguard switch and make sure that it works properly.

Installing safety barriers

When installing safety barriers within the maximum range of the Manipulator, combine safety functions such as SLP. Carefully take into account the size of the hand and the workpieces to be held so that no interference occurs between the operating parts and the safety barriers.

Installing safeguards

Design the safeguards so that they satisfy the following requirements:

- When using a key switch type safety device, use a switch that forcibly opens the interlock contacts. Do not use switches that open their contacts using the spring force of the interlock.
- When using an interlock mechanism, do not disable the interlock mechanism.

Considering the stopping distance

During operation, the Manipulator cannot stop immediately even if the safeguard is opened. Also, the stopping time and movement distance vary depending on the following factors.

- Hand weight, WEIGHT setting, ACCEL setting, workpiece weight, SPEED setting, movement posture, etc.

For the stopping time and movement distance of the Manipulator, refer to the following section.

[Appendix C: Stopping Time and Stopping Distance When Safeguard is Open](#)

Precautions for safeguard operation

Do not open the safeguard unnecessarily while the motor is energized. Frequent safeguard inputs will reduce the life of the relay.

- Normal relay lifespan: About 20,000 times

2.1.6 How to Move Arms with the Electromagnetic Brake

There are two methods to release the electromagnetic brake. Follow either method to release the electromagnetic brake and move the arms manually.

- **When using a brake release unit**
Follow the method when you just unpack the delivered boxes or when the Controller does not start up yet.
- **When using software**
Follow the method when you can use the software.

While the electromagnetic brake is on (such as in emergency mode), you cannot move any arm by pushing manually.

Arm Motion

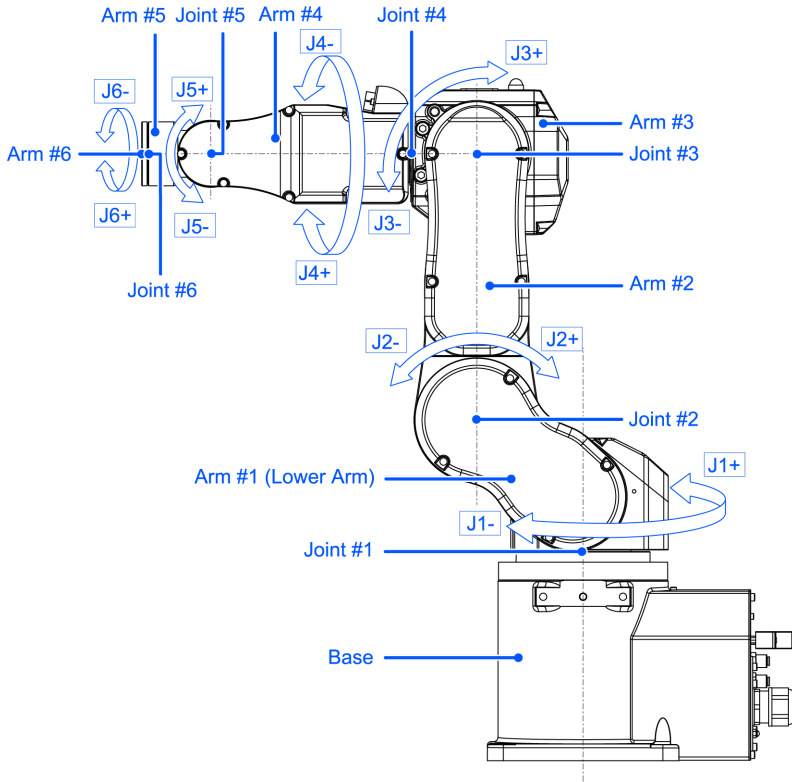

2.1.6.1 When using a brake release unit

This series has the Brake Release Unit as an option. For details, refer to the following section.

Options

2.1.6.2 When using software

⚠ CAUTION

- Normally, release the brakes of joints one at a time. If the brakes of two or more joints must be released simultaneously due to unavoidable reasons, use extreme care. Releasing the brakes of multiple joints simultaneously may cause the arm to fall in an unexpected direction, resulting in hands or fingers getting caught or damage or failure of the Manipulator.
- After releasing the brake, the arm may fall by its own weight or move to the unexpected direction. Make sure to prepare a countermeasure to prevent the arm from falling and check the operation environment is safe.
- Before releasing the brake, be sure to keep the emergency stop switch in an easily accessible location so that you can immediately press it if necessary. Otherwise, if the emergency stop switch is not easily accessible, you will be unable to immediately stop the arm falling due to an erroneous operation, which could lead to Manipulator damage or breakdown.

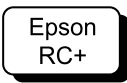

After releasing the Emergency Stop switch, execute the following command in [Command Window].

```
>Reset
>Brake Off, [The number (from 1 to 6) corresponding to the arm whose brake will be turned off]
```

Execute the following command to turn on the brake again.

```
>Brake On, [The number (from 1 to 6) corresponding to the arm whose brake will be turned on]
```

2.1.7 Precaution for Operation in Low Power Status

In the low power status, the Manipulator operates at low speed and low torque. However, comparatively high torque as shown in the table below may be generated to support the Manipulator’s own weight. Carefully operate the Manipulator since it may get your hands or fingers caught during operation. The Manipulator may also collide with peripheral equipment and cause equipment damage to or malfunction of the Manipulator.

Maximum Joint Torque in Low Power Status [Unit: N·m]

Joint		#1	#2	#3	#4	#5	#6
Joint Torque	C4-B601 **	102.29	118.94	38.97	14.46	13.25	7.99
	C4-B901 **	116.78	194.62	69.28			

⚠ CAUTION

- Carefully operate the Manipulator in the low power status. A comparatively high joint torque may be generated. It may cause your hands and fingers caught and/or cause equipment damage to or malfunction of the Manipulator as it may collide with peripheral equipment.

2.1.8 Warning Labels

The Manipulator has the following warning labels. Specific hazards exist in the vicinity of areas with the warning labels. Be thoroughly careful in handling. To ensure that the Manipulator is operated and maintained safely, be sure to follow the safety information and warnings indicated on the warning labels. Also, do not tear, damage, or remove these warning labels.

2.1.8.1 Warning Labels



Touching any internal electrified parts while the power is turned on may cause electric shock.

B



HOT Be careful not to burn yourself.

C



When releasing the brakes, be careful of the arm falling due to its own weight.

This warning label is attached on the Manipulator and optional brake release unit as well.

When the brake release unit is used:

When using a brake release unit to release brakes, refer to the following section.

[How to Move Arms with the Electromagnetic Brake](#)

2.1.8.2 Information Labels

1
This indicates the product name, model name, serial number, information of supported laws and regulations, product specifications (Weight, MAX.REACH, MAX.PAYLOAD, AIR PRESSURE, Motor Power), Main document No., manufacturer, importer, date of manufacture, country of manufacture, and the like.

For details, see the label affixed to the product.



This indicates the position for mounting eyebolts. Refer to the following section for examples of using eyebolts.

[Environment and Installation](#)

Location of Labels

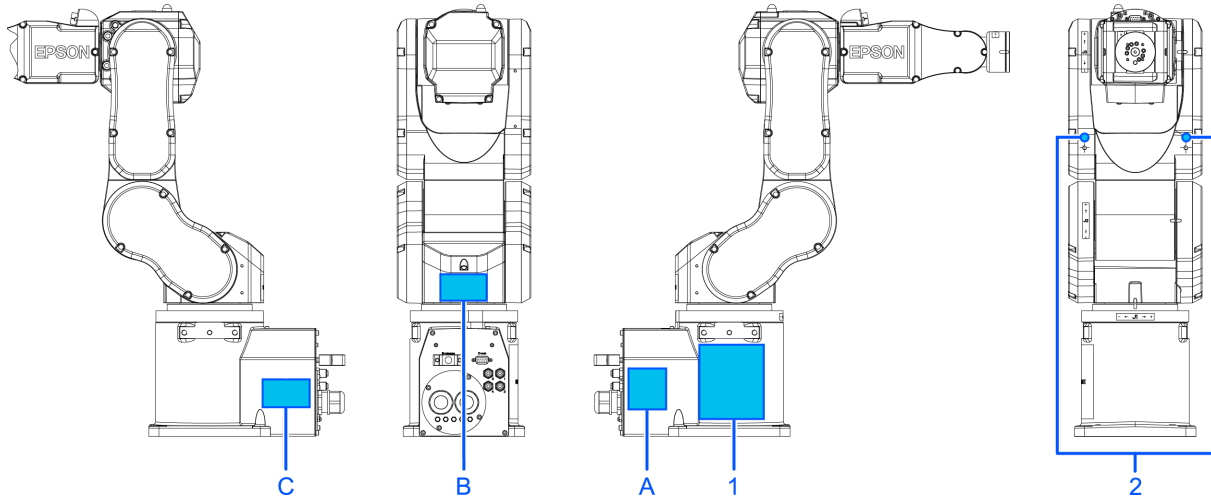

2.1.9 Responses for Emergencies or Malfunctions

2.1.9.1 When a Collision with the Manipulator Occurs

If the Manipulator has collided with a mechanical stop, peripheral device, or other object, discontinue use and contact the supplier.

2.1.9.2 Entanglement with the Manipulator

When the operator is caught between the Manipulator and a mechanical part such as a base table, press the emergency stop switch to release the brake on the subject arm, and then move the arm by hand.

How to release a brake

- When using a brake release unit, refer to the following section.
 - [Brake Release Unit](#)
- When using software, refer to the following section.
 - [When using software](#)

2.2 Specifications

2.2.1 Model Number

C4 - B601S□
 [a] [b][c][d]

- a: Arm length
 - 6: 600 mm (Model name: C4)
 - 9: 900 mm (Model name: C4L)
- b: Brake equipment
 - 1: Brakes on all joints
- c: Environment
 - S: Standard *2
 - C: Cleanroom & ESD (anti-static) *2

- d: Mounting type
 - □: Table top mounting
 - R: Ceiling mounting *1

*1 Manipulators are set to "Table Top mounting" at shipment. To use the Manipulators as "Ceiling mounting", you need to change the model settings. For details on how to change the model settings, refer to the following sections.

- **Changing the Robot**
- "Epson RC+ User's Guide - Robot Configuration"

*2 Equivalent to IP20

2.2.2 Part Names and Motion Range of Each Arm

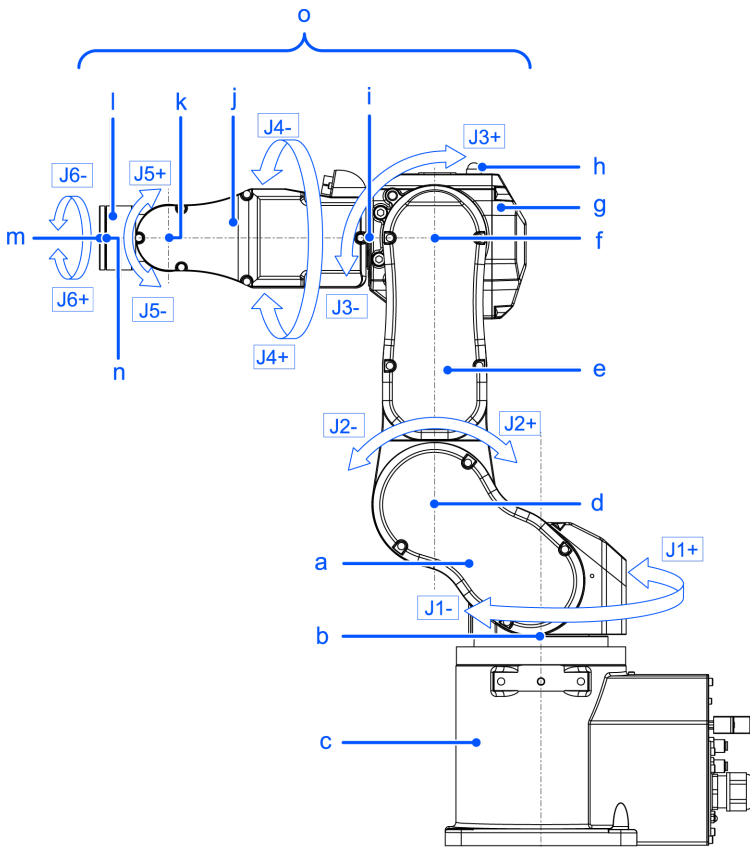

Symbol	Description
a	Arm #1 (Lower Arm)
b	Joint #1 (The whole Manipulator revolves.)
c	Base
d	Joint #2 (The lower arm swings.)
e	Arm #2
f	Joint #3 (The upper arm swings.)
g	Arm #3
h	LED Lamp (This lamp lights up while the motors are on.)
i	Joint #4 (The wrist revolves.)

Symbol	Description
j	Arm #4
k	Joint #5 (The wrist swings.)
l	Arm #5
m	Arm #6
n	Joint #6 (The hand rotates.)
o	Upper Arm (Arms #3 to #6)

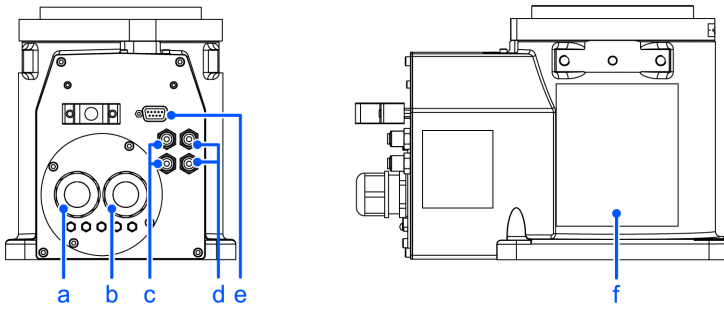

Symbol	Description
a	Signal cable
b	Power cable
c	Blue (fitting for $\varnothing 4$ mm tube)
d	White (fitting for $\varnothing 4$ mm tube)
e	User cable connector (9-pin D-sub connector)
f	Face plate (serial number of Manipulator)

KEY POINTS

When the LED lamp is lighting or the Controller power is on, the current is being applied to the Manipulator. (The LED lamp may not be seen depending on the Manipulator's posture. Be thoroughly careful.) Performing any work procedure with the power turned on is extremely dangerous and may result in electric shock and/or malfunction of the robot system. Before starting any maintenance work, be sure to turn off the Controller.

2.2.3 Outer Dimensions

2.2.3.1 C4-B601**

(Units: mm)

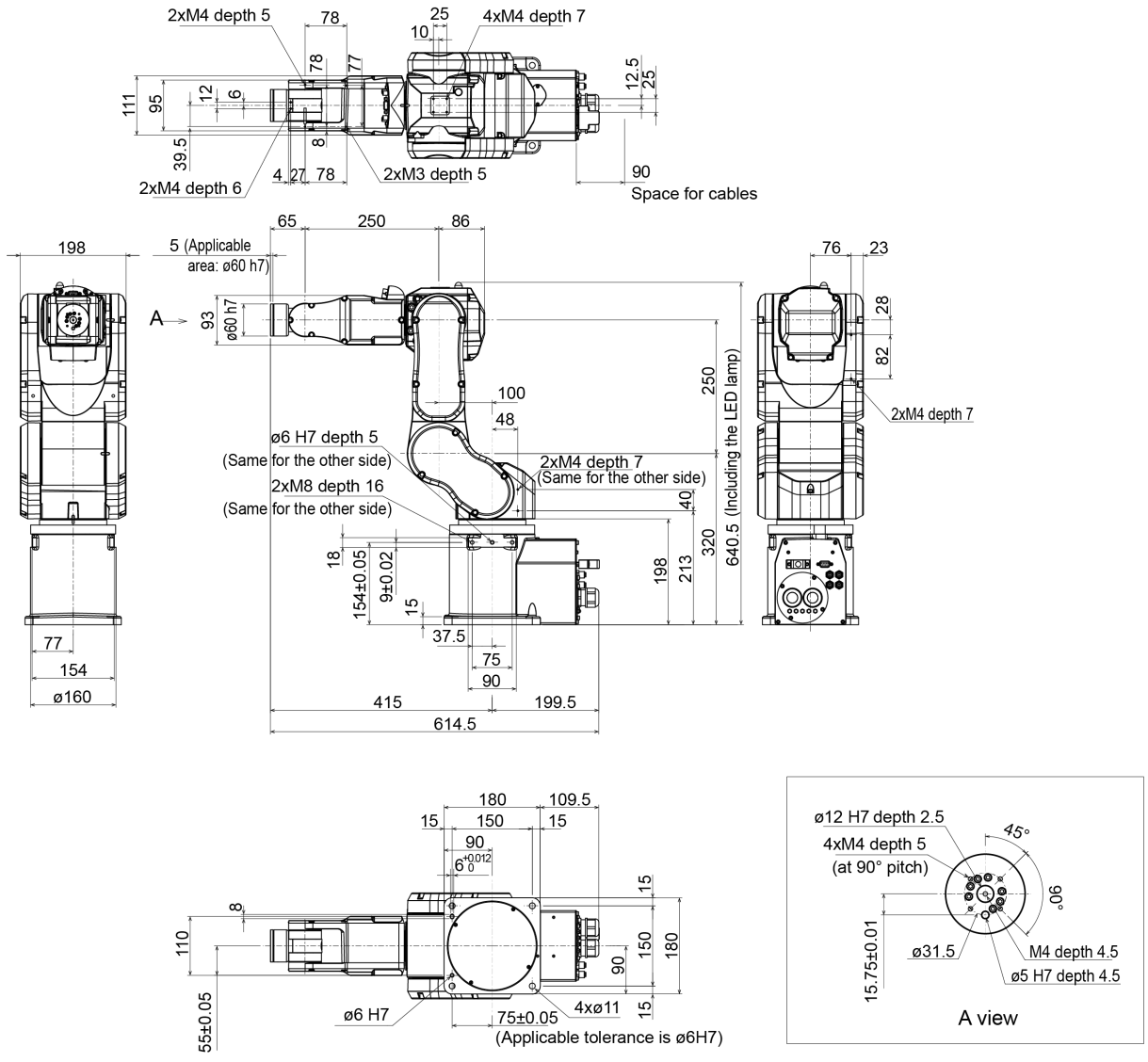

depth = depth of threaded hole

2.2.3.2 C4-B901**

(Units: mm)

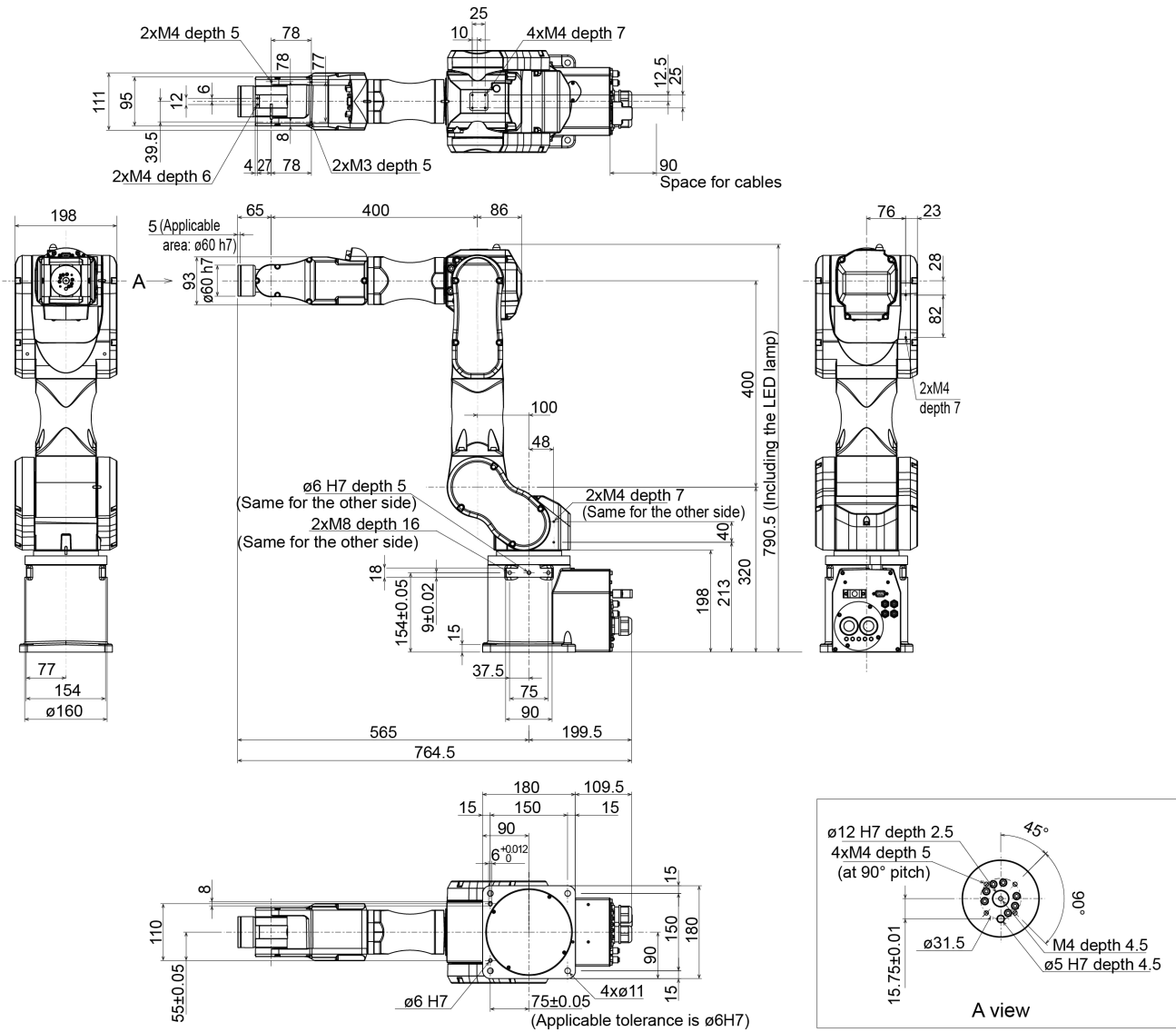

depth = depth of threaded hole

2.2.4 Standard Work Envelope

2.2.4.1 C4-B601**

(Units: mm)

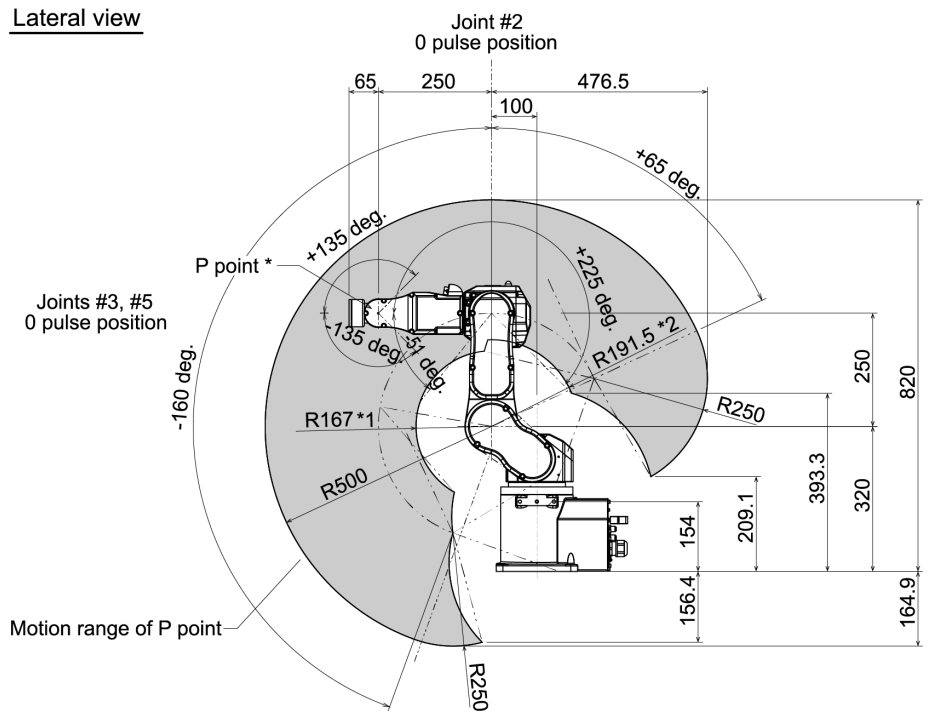
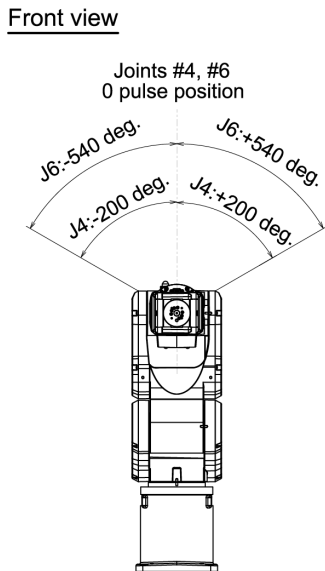
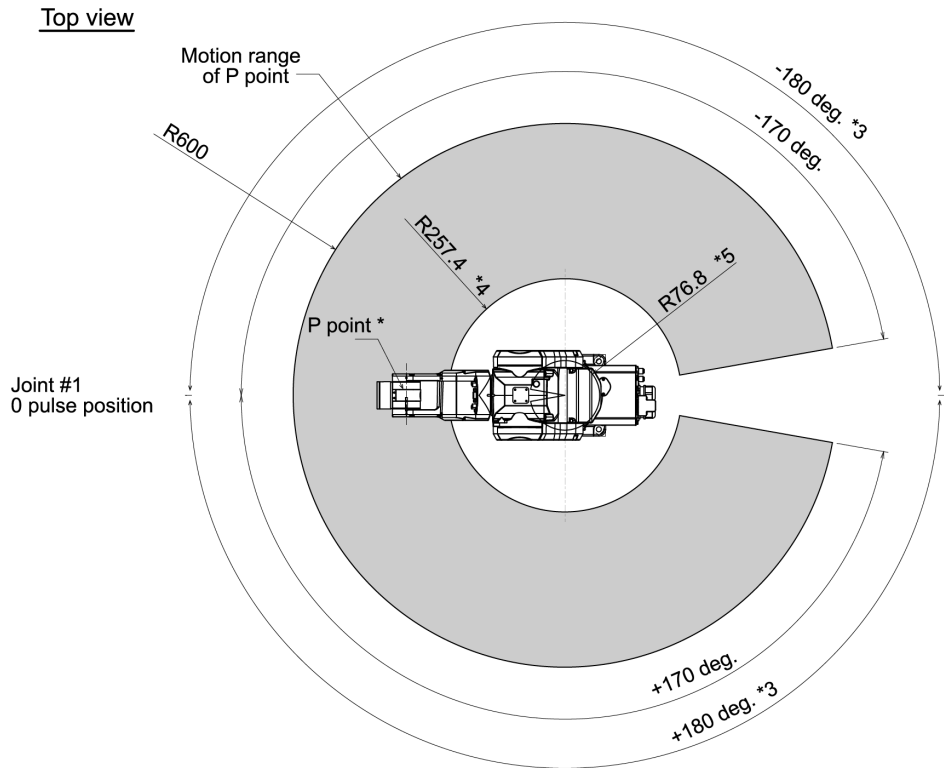

(deg. = °)

*P point: Intersection of the rotation centers for Joint #4, #5, and #6

*1: P point from lateral with Joint #3 declining -51° (Joint #2 center – P point center)

*2: P point from lateral with Joint #3 tilting up +225° (Joint #2 center – P point center)

*3: Joint #1 software limit maximum value ($\pm 180^\circ$)

*4: P point from top with Joint #3 declining -51° (Joint #1 center – P point center)

*5: P point from top with Joint #3 tilting up $+225^\circ$ (Joint #1 center – P point center)

CAUTION

- Pay attention to the arm pose of the basic arms (Arms #1, #2, and #3) when operating the Manipulator. Arm #5 moves keeping a constant angle regardless of the arm pose. Depending on the arm pose of the basic arms, the wrist may collide with the Manipulator. The collision may cause equipment damage to and/or malfunction of the Manipulator.

2.2.4.2 C4-B901**

(Units: mm)

Top view

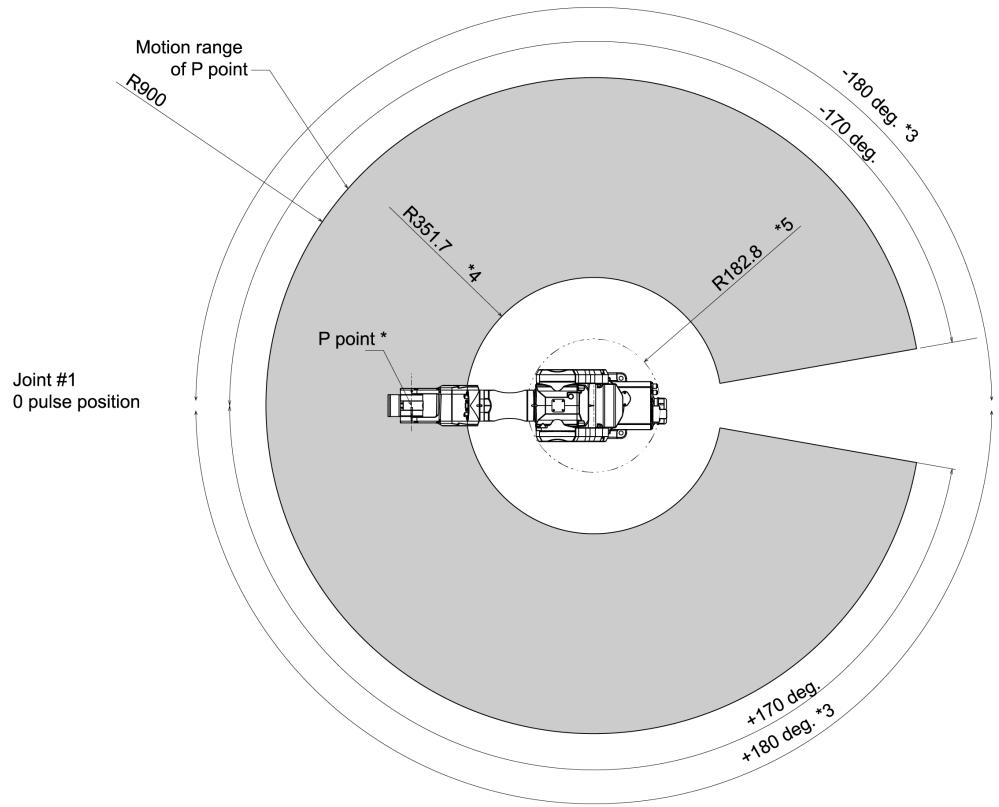

Front view

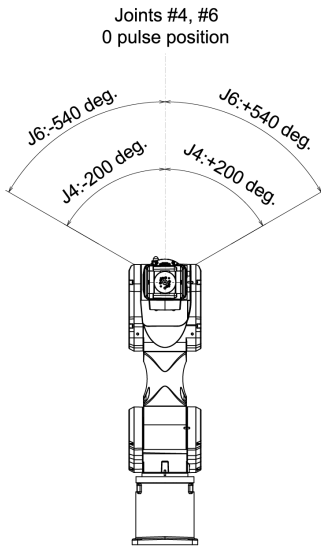

Lateral view

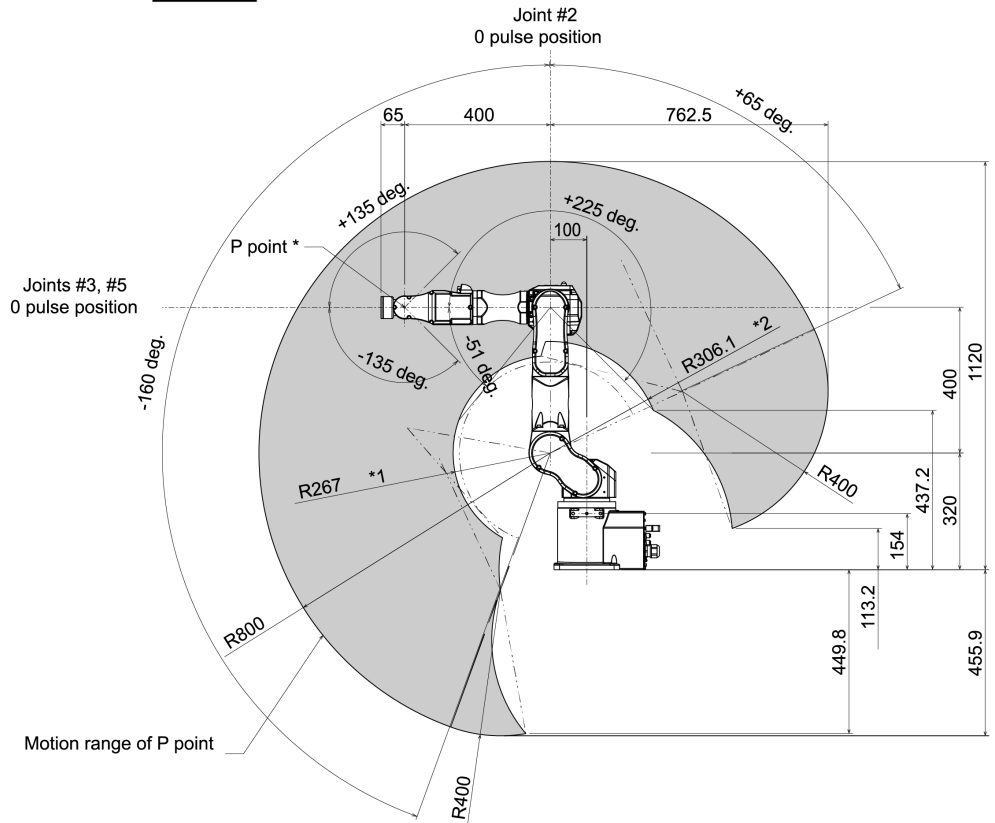

(deg. = °)

*P point: Intersection of the rotation centers for Joint #4, #5, and #6

*1: P point from lateral with Joint #3 declining -51° (Joint #2 center – P point center)

*2: P point from lateral with Joint #3 tilting up +225° (Joint #2 center – P point center)

*3: Joint #1 software limit maximum value ($\pm 180^\circ$)

*4: P point from top with Joint #3 declining -51° (Joint #1 center – P point center)

*5: P point from top with Joint #3 tilting up +225° (Joint #1 center – P point center)

CAUTION

- Pay attention to the arm pose of the basic arms (Arms #1, #2, and #3) when operating the Manipulator. Arm #5 moves keeping a constant angle regardless of the arm pose. Depending on the arm pose of the basic arms, the wrist may collide with the Manipulator. The collision may cause equipment damage to and/or malfunction of the Manipulator.

2.2.5 Specifications

2.2.5.1 Specifications Table

For the specifications tables of each model, refer to the following section.

[C4 Specifications](#)

2.2.5.2 Options

For details, refer to the following section.

[Options](#)

2.2.6 How to Set the Model

The Manipulator model for your system has been set before shipment from the factory.

CAUTION

- If changing the setting of the Manipulator model, be responsible and absolutely certain that the wrong Manipulator model is not set. Incorrect setting of the Manipulator model may result in abnormal or no operation by the Manipulator and could even cause safety problems.

If a custom specifications number (MT***) or (X***) is written on the face plate (serial number label), the Manipulator has custom specifications.

Models with custom specifications may require a different setting procedure. Check the custom specifications number, and contact the supplier for more information.

The Manipulator model is set from software. For details, refer to the following manual.

"Epson RC+ User's Guide - Robot Configuration"

2.3 Environment and Installation

The robot system should be designed and installed by people who have received installation training provided by Epson and the suppliers. Also, the laws and regulations of the installation country must be followed.

2.3.1 Environment

To ensure that the robot system operates and maintains maximum performance and to ensure its safe use, the robot system should be installed in an environment that meets the following requirements.

Item	Conditions
Ambient temperature *	Installation: 5 to 40°C Transport, storage: -20 to 60°C
Ambient relative humidity	Installation: 10 to 80% (no condensation) Transport, storage: 10 to 90% (no condensation)
Fast transient burst noise	1 kV or less (signal line)
Electrostatic noise	4 kV or less
Altitude	1000 m or less
Environment	<ul style="list-style-type: none"> ▪ Install indoors. ▪ Keep away from direct sunlight. ▪ Keep away from dust, oily smoke, salinity, metal powder, and other contaminants. ▪ Keep away from flammable or corrosive liquids and gases. ▪ Keep away from water. ▪ Keep away from shocks or vibrations. ▪ Keep away from sources of electric noise. ▪ Keep away from explosive areas. ▪ Keep away from large quantities of radiation.

* The ambient temperature requirement is for the Manipulator only. For details on the environment requirements for the connected Controller, refer to the Robot Controller manual.

KEY POINTS

If the Manipulator will be used in a location that does not meet the above requirements, please contact the supplier.

KEY POINTS

When used in a low-temperature environment near the minimum temperature specified in the product specifications, or when the unit is idle for a long period of time during holidays or at night, a collision detection error or similar error may occur immediately after the start of operation due to high resistance in the drive unit. In such cases, warm-up operation for about 10 minutes is recommended.

KEY POINTS

If there are conductive objects such as fences or ladders within 2.5 m of the Manipulator, these objects must be grounded.

Special environmental requirements

Manipulator surfaces are generally oil-resistant, but if special oils are to be used, oil resistance should be checked before use. For more information, please contact the supplier.

In environments with rapid changes in temperature and humidity, condensation may form inside the Manipulator.

When handling food directly, it is necessary to make sure that the Manipulator is not likely to contaminate the food. For more information, please contact the supplier.

The Manipulator cannot be used in corrosive environments where acids or alkalis are present. In environments where rust can easily form, such as those exposed to salt, rust may also form on the Manipulator.

WARNING

- Always use a circuit breaker for the Controller's power supply. Failure to use a circuit breaker may result in an electrical shock hazard or malfunction due to an electrical leakage. Select the correct circuit breaker based on the Controller that you are using. For details, refer to the following manual.

"Robot Controller Manual"

CAUTION

- When cleaning the Manipulator, do not rub it strongly with alcohol or benzene. Coated surfaces may lose their luster.

2.3.2 Manipulator Mounting Dimensions

Mounting Area

Also, besides the area required for installation of the Manipulator, Controller, peripheral equipment, and other devices, the following space should be provided at a minimum.

- Space for teaching
- Space for maintenance and inspections (for installing jigs and working safely within the safety barriers)
- Space for cables

KEY POINTS

- When installing the cables, be sure to maintain sufficient distance from obstacles.
- For the minimum bend radius of the M/C cable, refer to the following section.

C4 Specifications

- Also, leave enough space for other cables so that they are not forced to bend at extreme angles.

Manipulator Mounting Dimensions (C4 series) [Units: mm]

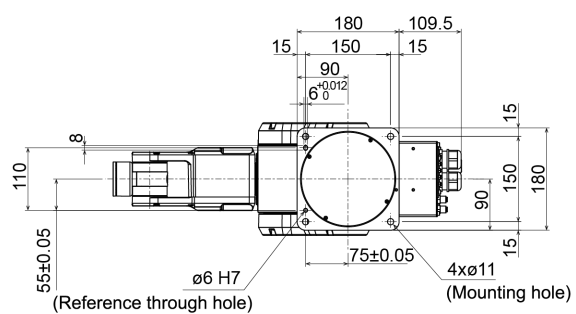
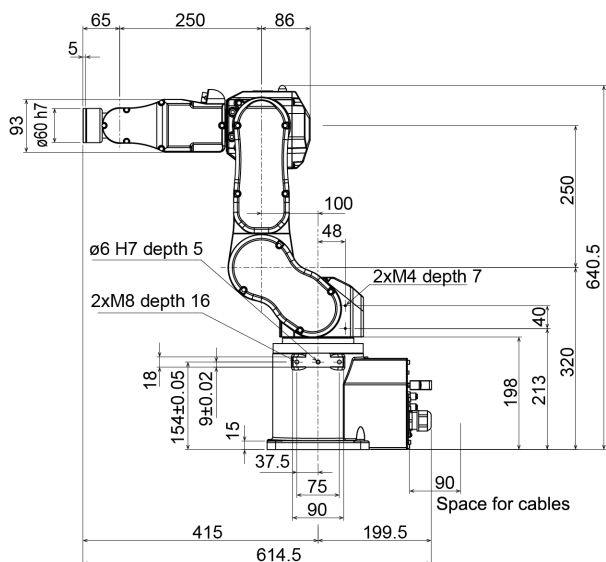

depth = depth of threaded hole

2.3.3 From Unpacking to Installation

Transportation and installation of the Manipulator and related equipment should be performed by people who have received installation training provided by Epson and the suppliers. Also, the laws and regulations of the installation country must be followed.

WARNING

- Only qualified personnel should perform sling work and operate a crane or a forklift. When these operations are performed by unqualified personnel, it is extremely hazardous and may result in serious bodily injury and/or severe equipment damage to the robot system
- When hoisting the Manipulator, use your hands to balance it. Losing balance may cause the Manipulator to drop, which is extremely hazardous and may result in serious injury and/or severe damage to the robot system.
- To ensure safety, be sure to install safeguards for the robot system. For more information on safeguards, refer to the following manual.
"Epson RC+ User's Guide - Safety - Installation and Design Precautions "
- Install the Manipulator in a location with sufficient space so that a tool or a work piece does not touch a wall or a safeguard when the Manipulator extends its arm fully while holding a work piece. If the tool or the workpiece tip reaches a wall or safeguards, it is extremely hazardous and may result in serious bodily injury and/or severe equipment damage to the robot system.
- Be sure to anchor the Manipulator before turning on the power or operating it. Turning on the power or operating the Manipulator while it is not anchored may cause the Manipulator to fall over, which is extremely hazardous and may result in serious injury and/or severe damage to the robot system.
- Before installing or operating the Manipulator, make sure that no parts of the Manipulator are missing and that it has no damage or other external defects. Missing parts or damage may cause malfunction of the Manipulator, is extremely hazardous, and may result in serious injury and/or severe equipment damage to the robot system.

CAUTION

- Use a cart or the like to transport the Manipulator in the same status as it was delivered.
- When removing the fixing bolts securing the Manipulator to the transportation pallet and the packing box or the anchor bolts, support the Manipulator to prevent it falling. Removing the fixing bolts or anchor bolts without supporting the Manipulator may cause it to fall, catching your hands or feet.
- The Manipulator should be transported by two or more people or secured to transporting equipment. Also, do not hold the bottom of the base (the screened parts in the figure). Holding these parts by hand is extremely hazardous and may cause your hands and fingers caught.
 - C4-B601**

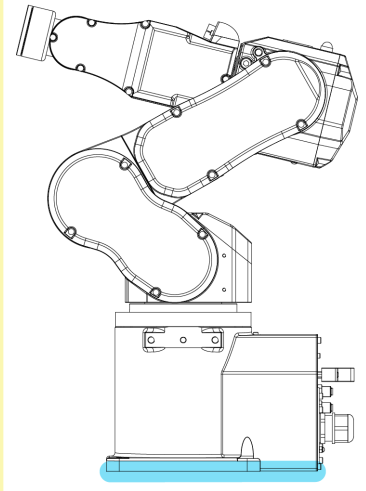

- C4-B901**

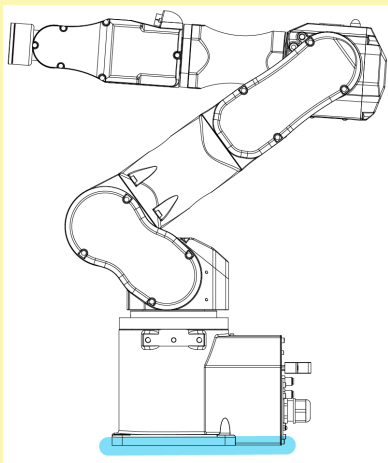

Manipulator weight

C4-B601**: C4	C4-B901**: C4L
27 kg: 59.5 lb	30 kg: 66.1 lb

- Take extra care when transporting the Manipulator. You may hit and damage the connector.



- During unpacking and relocation, avoid applying external force to the arms and motors of the Manipulator.
- When transporting the Manipulator over long distances, secure it directly to transporting equipment so that it will not fall. If necessary, pack the Manipulator using the same packaging as delivery.
- The Manipulator must be installed to avoid interference with surrounding buildings, structures, and other machines and equipment that may create a trapping hazard or pinch points.
- Resonance (resonating sound or minute vibrations) may occur during Manipulator operation depending on the rigidity of the base table. If the resonance occurs, improve the rigidity of the base table or change the speed or acceleration and deceleration settings of the Manipulator.

Fixing bolt

For details on the dimensions, refer to the following sections.

Manipulator Mounting Dimensions

There are four threaded holes for the Manipulator base. Use M8 mounting bolts conforming to the strength equivalent to ISO898-1 property class 10.9 or 12.9. Tightening torque: $32.0 \pm 1.6 \text{ N}\cdot\text{m}$ ($326 \pm 16 \text{ kgf}\cdot\text{cm}$)

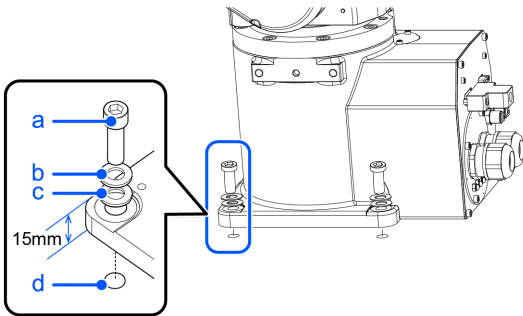

Symbol	Description
a	4×M8×35
b	Spring washer
c	Plain washer
d	Threaded hole (20 mm or more depth)

Base table

A base table for anchoring the Manipulator is not supplied. The base table must be fabricated or obtained by the customer.

The shape and size of the base table vary depending on the application of the robot system. As a reference when designing the base table, the requirements from the Manipulator side are shown here.

The base table must not only be able to bear the weight of the Manipulator but also be able to withstand the dynamic movement of the Manipulator when it operates at maximum acceleration/deceleration. Ensure that there is enough strength on the base table by attaching reinforcing materials such as crossbeams.

Followings are the torque and reaction force produced by the movement of the Manipulator.

	C4-B601 **	C4-B901**
Maximum rotating torque on horizontal surface (N·m)	500	700
Maximum reaction force in horizontal direction (N)	800	800
Maximum rotating torque on vertical surface (N·m)	600	1000
Maximum reaction force in vertical direction (N)	2500	2500

The plate for the Manipulator mounting face should be at least 30 mm thick and made of steel for reducing vibrations.

A surface roughness of 25 μm or less at the maximum height is appropriate.

The base table must be secured on the floor to prevent it from moving.

The Manipulator installation surface should have a flatness of 0.5 mm or less and an inclination of 0.5° or less. If the installation surface does not have the proper flatness, the base of the Manipulator may be damaged or the robot may be unable to operate at maximum performance.

When using a leveler to adjust the height of the base table, use a screw with M16 diameter or more.

Connector

If passing cables through the holes in the base table, refer to the connector dimensions in the figures below. (Units: mm)

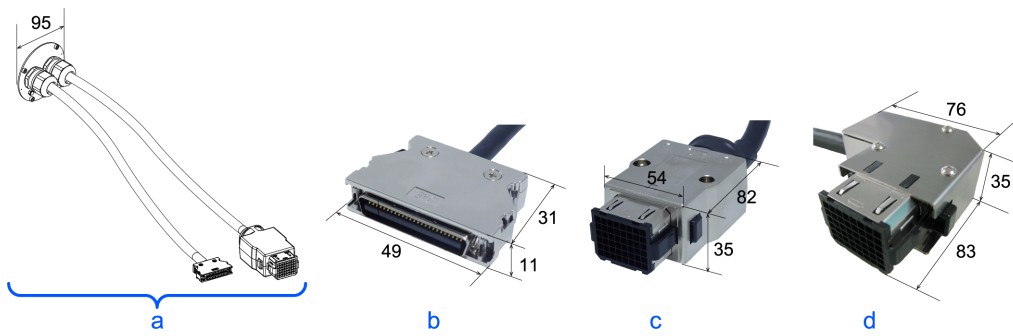

Symbol	Description
a	M/C cable
b	Signal cable connector
c	Power cable connector
d	Power cable connector (L-shaped)

Do not remove the M/C cables from the Manipulator.

KEY POINTS

For details on the environmental requirements for the space when housing the Controller in the base table, refer to the Robot Controller manual.

When using the Manipulator in the clean room, follow the steps below before the installation.

1. Unpack the Manipulator outside of the cleanroom.
2. Secure the Manipulator to transporting equipment (or a pallet) with bolts so that the Manipulator does not fall down.
3. Wipe off any dust on the Manipulator using a lint-free cloth that was dipped in ethyl alcohol or distilled water.
4. Carry the Manipulator into the cleanroom.
5. Secure the Manipulator to the base table.

2.3.4 Connecting the Cables

WARNING

- Before performing any replacement work, turn off the Controller and related equipment, and unplug the power cable from the power source. Performing any work procedure with the power turned on is extremely dangerous and may result in electric shock and/or malfunction of the robot system.
- Be sure to connect the AC power cable to a power outlet. Do not connect it directly to a factory power source. To perform the power supply lockout, remove the power plug. Working while connecting the AC power cable to a factory power source may result in electric shock and/or malfunction of the robot system.
- Be sure to connect the cables properly. Do not put heavy objects on the cables, bend or pull on the cables forcibly, or allow the cables to be pinched. Damaged cables, broken wires, or contact failure is extremely hazardous and may result in electric shock and/or malfunction of the robot system.
- Be sure to turn off the power and tag out (e.g., with a "DO NOT TURN ON" sign) before performing wiring. Performing any work procedure with the power turned on is extremely dangerous and may result in electric shock and/or malfunction of the robot system.
- The Manipulator is grounded by connecting it to the Controller. Ensure that the Controller is grounded and the cables are correctly connected. If the ground wire is improperly connected to ground, it may result in the fire or electric shock.
- Turn off the power to the Robot Controller and brake release unit when connecting or replacing the brake release unit or external short connector. Inserting or removing connectors with the power on may result in electric shock and/or malfunction of the robot system.

CAUTION

- When connecting the Manipulator and the Controller, check that the serial numbers match for each device. Improper connection between the Manipulator and the Controller may not only lead to malfunction of the robot system but also safety problems. The connection method between the Manipulator and the Controller varies depending on the Controller. For details on the connection, refer to the following manual.
"Robot Controller Manual"
- Only authorized or certified personnel should perform wiring. Wiring by unauthorized or uncertified staff may result in bodily injury and/or malfunction of the robot system.
- Operating the Manipulator without a brake release unit or external short connector connected may cause the brake to fail to release, possibly damaging the brake.
After using the brake release unit, be sure to connect the external short circuit connector to the Manipulator or make sure to leave the connector for the brake release unit connected.

Cleanroom-model Manipulator

When the Manipulator is a model with cleanroom specifications, an exhaust system must be connected. For the exhaust system, refer to the following section.

C4 Specifications

Connection procedure for M/C cable

Connect the power connector and signal connector of the M/C cable to the Controller.

2.3.5 User Wires and Pneumatic Tubes

⚠ CAUTION

- Only authorized or certified personnel should perform wiring. Wiring by unauthorized or uncertified staff may result in bodily injury and/or malfunction of the robot system.

User electrical wires and pneumatic tubes are contained in the cable unit.

Electrical Wires

Rated Voltage	Allowable Current	Wires	Nominal Sectional Area	Outer Diameter	Note
AC/DC30V	1 A	9	0.211 mm ²	ø8.3 ± 0.3 mm	Shielded

		Manufacturer	Type
9 pin	Suitable connector	JAE	DE-9PF-N (solder type), DEU-9PF-F0 (crimping type)
	Clamp hood	JAE	DE-C8-J9-F2-1R (Connector setscrew: #4-40 NC)

Pins with the same number, indicated on the connectors on both ends of the cables, are connected.

Pneumatic Tubes

Maximum Working Pressure	Number of Tubes	Outer Diameter × Inner Diameter
0.59 MPa (6 kgf/cm ² : 86 psi)	4	ø4 mm×ø2.5 mm

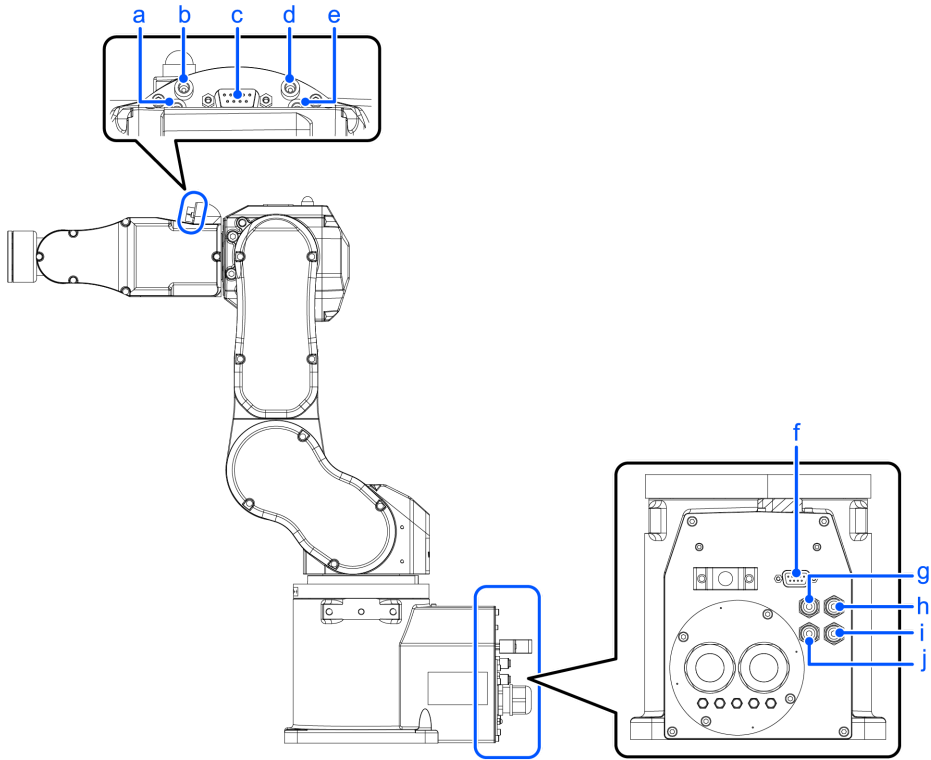

Tubes with the same number are connected.

Symbol	Description
a	No.1
b	No.2
c	User cable connector (9-pin D-sub connector)
d	No.3
e	No.4
f	User cable connector (9-pin D-sub connector)
g	No.3: Blue
h	No.1: White
i	No.2: White
j	No.4: Blue
k	Fitting for \varnothing 4 mm tube

2.3.6 Checking the Basic Orientation

After installing the Manipulator and setup the operating environment, check if it moves to the basic position properly.

Follow the steps below to set the basic orientation of the Manipulator shown below as the origin position.

1. Start Epson RC+.
Double click the [Epson RC+] icon on the desktop.
2. Open the command window.
Epson RC+ menu-[Tools]-[Command Window]
3. Execute the following command in [Command Window].

```
>Motor On
>Go Pulse (0,0,0,0,0,0)
```

KEY POINTS

If "Error 4505: cannot be turned on the motor because the Safety Board is issuing a stop signal." occurs, use one of the following methods to move the Manipulator to its basic orientation.

- Release the brake and push the arm by hand to move it within the motion range. Then follow the steps above.
For details on releasing brake, refer to the following section.
[How to Move Arms with the Electromagnetic Brake](#)
- Press the TP3 or TP4 command button [Pulse0] to move the Manipulator to its basic orientation. For details, refer to the following manual.
For TP3:
"Robot Controller Option Teach Pendant TP3 Operation 3.1.3 Command Buttons"
For TP4:
"Robot Controller Option Teach Pendant TP4 3.2.5.13.2 Command Buttons"
"Robot Controller Option Teach Pendant TP4 3.2.9.7.2 Command Buttons"

If the Manipulator cannot be in the basic orientation shown below, please contact the supplier.

Basic orientation (0 pulse position)

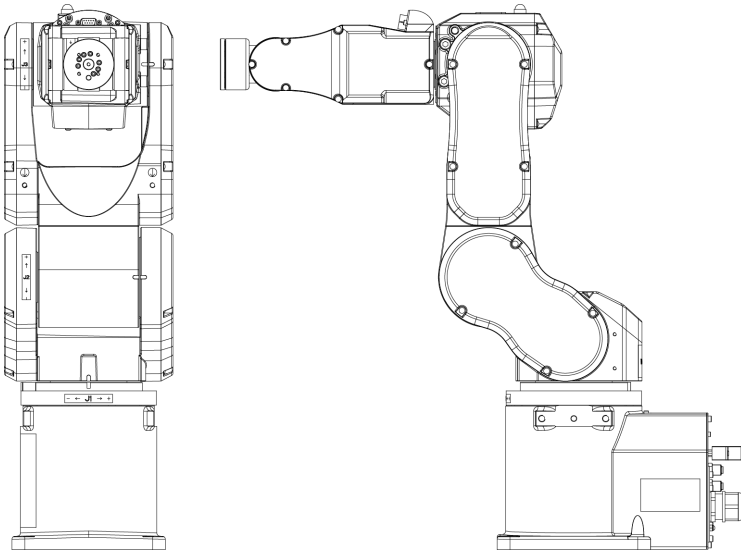

2.3.7 Relocation and Storage

2.3.7.1 Safety Information for Relocation and Storage

Pay attention to the following requirements when relocating, storing, and transporting the Manipulators.

Transportation and installation of the Manipulator and related equipment should be performed by people who have received installation training provided by Epson and the suppliers. Also, the laws and regulations of the installation country must be followed.

⚠ WARNING

- Only qualified personnel should perform sling work and operate a crane or a forklift. When these operations are performed by unqualified personnel, it is extremely hazardous and may result in serious bodily injury and/or severe equipment damage to the robot system

⚠ CAUTION

- Before relocating, fold the arm and secure it tightly with a cable tie to prevent hands or fingers from getting caught in the Manipulator.
- When removing the anchor bolts, support the Manipulator so that it does not fall. Removing the anchor bolts without supporting the Manipulator can cause it to fall, causing hands or feet to get caught.
- The Manipulator should be transported by two or more people or secured to transporting equipment. Also, do not hold the bottom of the base. Holding these parts by hand is extremely hazardous and may cause your hands and fingers caught.

During unpacking and relocation, avoid applying external force to the arms and motors of the Manipulator.

When transporting the Manipulator over long distances, secure it directly to transporting equipment so that it will not fall. If necessary, pack the Manipulator using the same packaging as delivery.

When the Manipulator is reassembled and used for a robot system again after an extended period of storage, perform a test run to verify that it works properly before starting the main operation.

Manipulators should be transported and stored under the following conditions: Temperature: -20 to +60°C, Humidity: 10 to 90% (no condensation)

If condensation has formed on the Manipulator during transportation or storage, do not turn on the power until the condensation is removed.

Do not subject the Manipulator to excessive impacts or vibrations during the transportation process.

Relocation

Follow the procedures described below when relocating the Manipulator.

1. Turn off the power for all devices and unplug the power cable connector and signal cable connector from the Controller.
Do not remove the M/C cables (power cable and signal cable) from the Manipulator.

KEY POINTS

Remove the mechanical stops if using them to limit the motion range. For details on the motion range, refer to the following section.

Setting the Work Envelope by Mechanical Stops

2. Unscrew the anchor bolts. Then, remove the Manipulator from the base table.

3. ■ C4-B601**

Position the Manipulator as shown in the figure. Then, secure the Manipulator to the transporting equipment or have at least two people to relocate the Manipulator. (Recommend: Joint #2 +65°. Joint #3 -51°)

Do not hold the bottom of the base (the screened parts in the figure). Holding these parts by hand is extremely hazardous and may cause your hands and fingers caught.

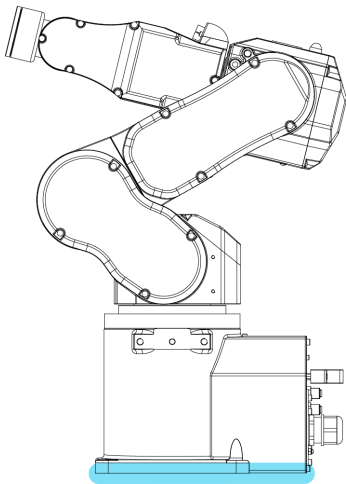

- C4-B901**

Position the Manipulator as shown in the figure. Then, secure the Manipulator to the transporting equipment or have at least three people to relocate the Manipulator.

(Recommend: Joint #2 +53°. Joint #3 -51°)

Do not hold the bottom of the base (the screened parts in the figure). Holding these parts by hand is extremely hazardous and may cause your hands and fingers caught.

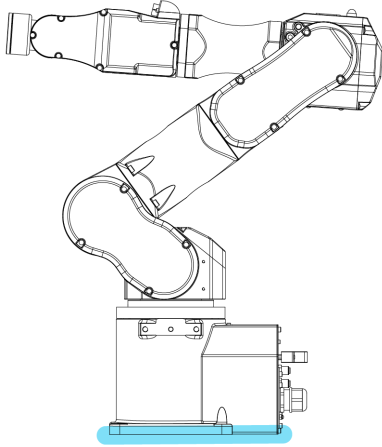

Manipulator weight

C4-B601** : C4	C4-B901** : C4L
27 kg: 59.5 lb	30 kg: 66.1 lb

Using eyebolts

Check that the eyebolts are securely fastened before transporting the Manipulator. After transporting the Manipulator, remove the eyebolts and keep them for future use.

The eyebolts and wire must be strong enough to withstand the weight (See the figures below).

If you use the eyebolts to lift up the Manipulator, be sure to use the bifilar wire of 1 m long or more to avoid contact with the Arm #4 side cover.

Also, the Manipulator may swing while being lifted up even when using the appropriate length of wire, so be sure to handle it with care.

Take extra care if you use the wire of 240 mm-long or shorter (for C4-B601**), or 360 mm-long or shorter (for C4-B901**), to lift the Manipulator, because the wire is likely to touch the Arm #4 side cover and break the Manipulator.

C4-B601**

- Lifting load: 27 kg: 59.5 lb

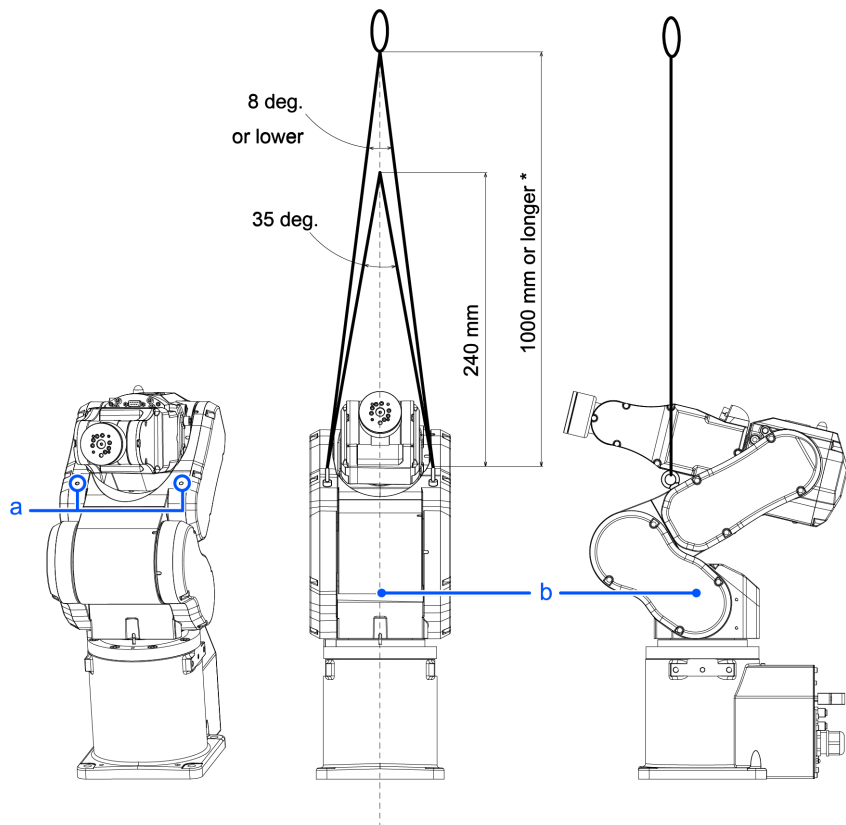

(deg. = °)

Symbol	Description
a	Threaded holes for eyebolts: 2×M6 depth 12.5
b	Center of gravity

* Use the wire of 1000 mm or longer to avoid contact with Manipulator.

C4-B901**

- Lifting load: 30 kg: 66.1 lb

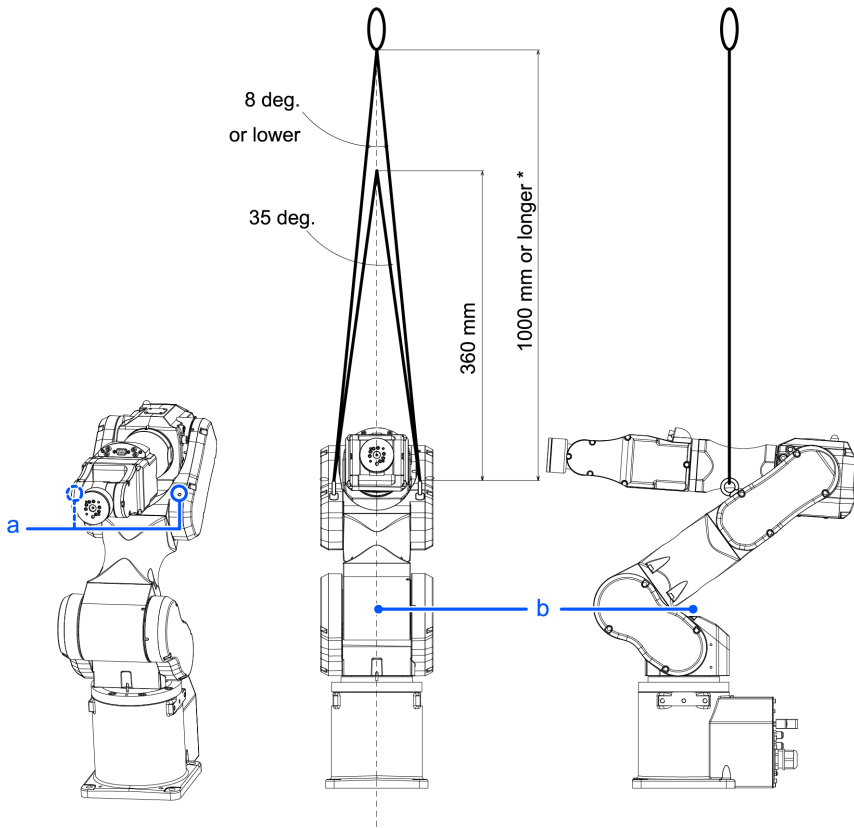

(deg. = °)

Symbol	Description
a	Threaded holes for eyebolts: 2×M6 depth 12.5
b	Center of gravity

* Use the wire of 1000 mm or longer to avoid contact with Manipulator.

⚠ CAUTION

- Remove the eyebolts from the Manipulator after transportation/relocation is completed. If the Manipulator is operated with the eyebolts left on it, the arm may collide with the eyebolts and it may cause equipment damage to and/or malfunction of the Manipulator.

2.4 Setting the Hand

2.4.1 Installing the Hand

The hand (end effector) must be prepared by the customer. For details on attaching the hand, refer to the following manual. "Hand Function Manual"

Flange dimensions of the wrist attached to the end of Arm #6 is as below.

⚠ WARNING

- Before attaching a hand or peripheral equipment, be sure to always turn off the Controller and related equipment and unplug the power cables. Performing any work procedure with the power turned on is extremely dangerous and may result in electric shock and/or malfunction of the robot system.

⚠ CAUTION

- When the hand is equipped with a workpiece gripping mechanism, ensure that the wiring and pneumatic tubes do not cause the hand to release the workpiece when the power is turned off. When the wiring and pneumatic tubes are not designed for the hand to maintain its grip on the workpiece when the power is turned off, pressing the emergency stop switch releases the workpiece, which may damage the robot system and the workpiece.

By default, all I/Os are designed to automatically turn off (0) when the power is shut off, when an emergency stop is triggered, or by the robot system's safety function.

However, I/Os set with the Hand function does not turn off (0) when executing the Reset statement, or when performing an emergency stop.

For the risk of the residual air pressure, conduct a risk assessment on the equipment and take the necessary protective measures.

Wrist flange

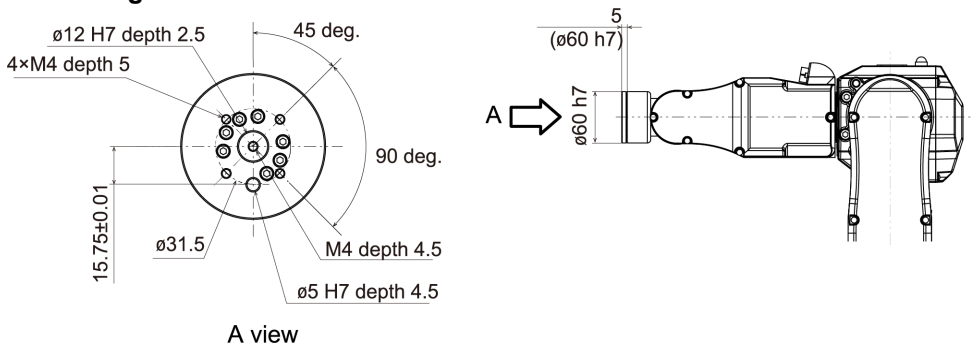

* Applicable area

Arm #6

Attach the hand to the end of the Arm #6 using the M4 bolts.

Layout

When attaching and operating a hand, the hand may come into contact with the Manipulator body due to the outer diameter of the hand, the size of the workpiece, or the position of the arm. Carefully consider the interference area of the hand when designing the system layout.

Compatibility with PS series or ISO flange

To install the hand used in the PS series or the hand which has flange conforming to ISO standard to the C4 series, we provide the optional PS Compatible Plate. For details, refer to the following section.

Options

2.4.2 Attaching Cameras and Valves

Decks are equipped to Arms #3 and #5 to enable the easy installation of air valve. If the payload exceeds the maximum payload, refer to the following section.

"WEIGHT Setting - Restrictions on payload exceeding the maximum payload"

To mount the camera, the camera plate unit is necessary. We provide the optional Camera Plate Unit. For details, refer to the following section.

Options

(Units: mm)

C4-B601**

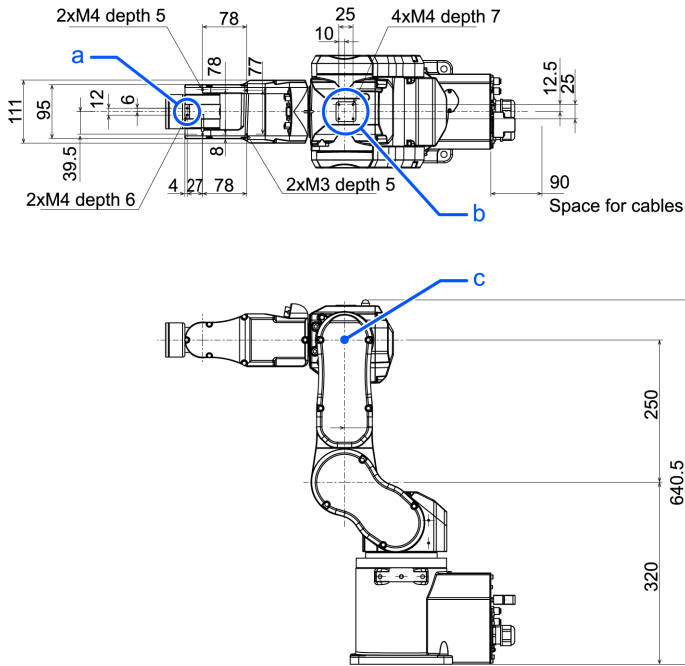

Symbol	Description
a	Arm #5 Deck
b	Arm #3 Deck
c	Rotation center of the upper arm

C4-B901**

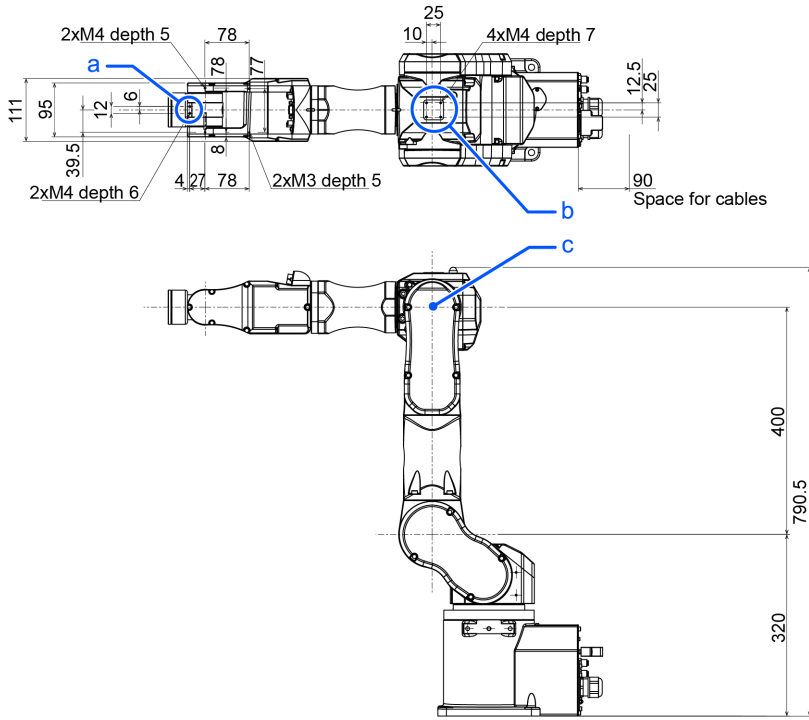

Symbol	Description
a	Arm #5 Deck
b	Arm #3 Deck
c	Rotation center of the upper arm

2.4.3 WEIGHT and INERTIA Settings

The WEIGHT and INERTIA commands are for setting the load parameters of the Manipulator. These settings optimize the Manipulator motion.

- **WEIGHT Setting**
The WEIGHT command is for setting the load weight. The more the load weight increases, the more the speed and acceleration/deceleration are reduced.
- **INERTIA Setting**
The INERTIA command is for setting the inertia moment and the eccentricity of the load. The more the inertia moment increases, the more the acceleration and deceleration of the Arm #6 are reduced. The more the eccentricity increases, the more the acceleration and deceleration for the Manipulator movement are reduced.

To ensure that the Manipulator is functioning properly, keep the load (the sum of the weights of the hand and workpiece) and the moment of inertia of the load within the rated values, and do not allow for eccentricity from the center of the Arm #6. If the load or the inertia moment exceeds the ratings or if the load becomes eccentric, follow the steps below to set parameters.

- **WEIGHT Setting**
- **INERTIA Setting**

Setting parameters makes the operation of the Manipulator optimal, reduces vibration to shorten the operating time, and improves the capacity for larger loads. This also works to curb any persistent vibration that may occur when the hand and workpiece have a large moment of inertia.

You can also perform settings using the "Weight, Inertia, and Eccentricity/Offset Measurement Utility."

For details, refer to the following manual.

"Epson RC+ User's Guide - Weight, Inertia, and Eccentricity/Offset Measurement Utility"

The allowable load for C4 series Manipulators is up to 4 (5) kg*.

Due to the limitations of the moment and moment of inertia shown in the table below, the load (hand + workpiece) should also meet these conditions.

If force is applied to the Manipulator instead of weight, it should not exceed the values shown in the table below.

* If the payload exceeds the maximum payload, refer to the following section.
"WEIGHT Setting - Restrictions on payload exceeding the maximum payload"

Allowable Load

Joint	Allowable moment	(GD ² /4) Allowable Moment of Inertia
Joint #4	4.41 N·m (0.45 kgf·m)	0.15 kg·m ²
Joint #5 *	4.41 N·m (0.45 kgf·m)	0.15 kg·m ²
Joint #6	2.94 N·m (0.3 kgf·m)	0.1 kg·m ²

Moment

The moment indicates amount of torque applied on the joint in order to support the gravity on the load hand + workpiece). The moment increases as weight of the load and amount of eccentricity increase. As this also increases the load applied on the joint, make sure to keep the moment within the allowable value.

A maximum torque (T) is calculated by the following formula.

$$T = m \text{ (kg)} \times L \text{ (m)} \times g \text{ (m/s}^2\text{)}$$

- m: Weight of load (kg)
- L: Eccentricity of load (m)
- g: Gravitational acceleration (m/s²)

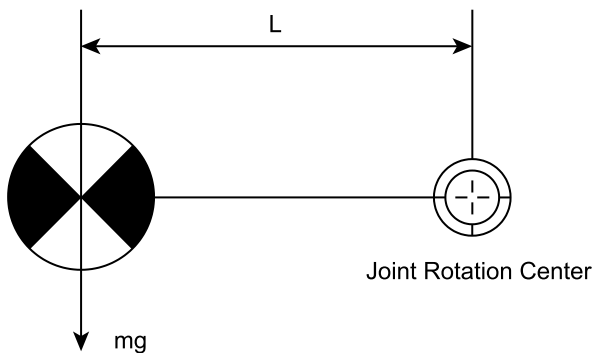

The figure below shows distribution of the center of gravity when the volume of the load (hand + workpiece) is small. Design the hand so that the center of gravity is within the allowable moment.

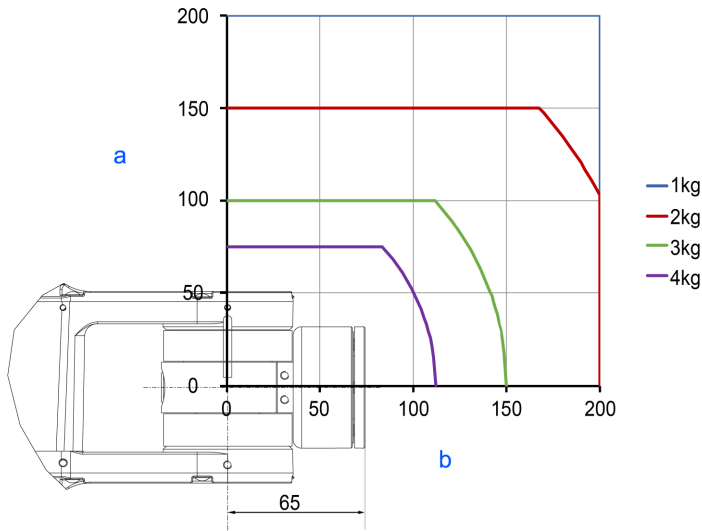

Symbol	Description
a	Distance from the center of Arm #* rotation [mm]
b	Center of gravity of load from the Arm #* rotation center [mm]

Max. Eccentricity of Load (Distance between the joint rotation center and the load’s center of gravity)

Axis	WEIGHT 1 kg	WEIGHT 2 kg	WEIGHT 3 kg	WEIGHT 4 kg
#4	200 mm	200 mm	150 mm	112 mm
#5	200 mm	200 mm	150 mm	112 mm
#6	200 mm	150 mm	100 mm	75 mm

(The maximum eccentricity of load is restricted to 200 mm or less.)

When calculating the critical dimension of the load using the allowable moment and inertia moment, the calculated value represents a distance from the Arm #6 rotation center, not the distance from the flange. To calculate the distance from the flange to the load’s center of gravity, subtract the distance from the center of the Arm #5 rotation center to the flange (=65 mm) as shown in the example below.

Example: Calculate the critical dimension of the load on the Arm #5 (A) when a 2.5 kg load is on the Arm #6 rotation center line (B = 0)

Center of gravity by the allowable moment control: $4.41 \text{ N}\cdot\text{m} / (2.5 \text{ kg} \times 9.8 \text{ m/s}^2) = 0.18 \text{ m} = 180 \text{ mm}$

Due to the allowable moment control, center of gravity for the load limit is 180 mm from the Arm #5 rotation center.

Distance from the flange to the center of gravity for the load limit $A = 180 \text{ mm} - 65 \text{ mm} = 115 \text{ mm}$

Critical Dimension of Load

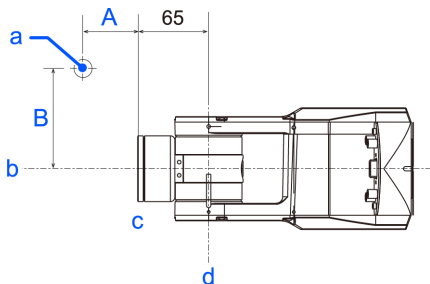

(Units: mm)

Symbol	Description
a	Load center of gravity position
b	Arm #6 rotation center
c	Flange
d	Arm #5 rotation center

2.4.3.1 WEIGHT Setting

⚠ CAUTION

- Set the total weight of the hand and the workpiece smaller than the maximum payload.
 The C4 Manipulators can operate without limitations on the condition unless and until the load exceeds this maximum payload. When the payload of the Manipulator exceeds the maximum payload, refer to the section "Restrictions on payload exceeding the maximum payload" in the later part of this section for details.
 Always set the Weight parameters of the WEIGHT command according to the load. Setting a value smaller than the actual weight may cause errors or impact that not only impair full functionality but also shorten the life of the mechanical components.

The acceptable weight capacity (hand + workpiece) for C4 Manipulators is as follows:

Rated	Maximum
1 kg	4 (5) kg*

When the load exceeds the rating, change the setting of the weight parameter. After changing the Weight parameter setting, the maximum acceleration/deceleration and speed of the robot system corresponding to the load is set automatically.

* If the payload exceeds the maximum payload, refer to the following section.
 "WEIGHT Setting - Restrictions on payload exceeding the maximum payload"

Setting method of Weight parameters

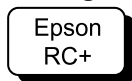

Select [Tools]-[Robot Manager]-[Weight] panel and set the value in [Weight:]. You may also execute the Weight command from [Command Window].

Load on the Manipulator

Mounting location of the load

C4-B601**

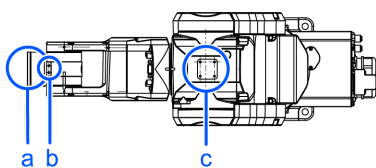

Symbol	Description
a	Load on the fore end of Arm #6

Symbol	Description
b	Arm #5 deck
c	Arm #3 deck

C4-B901**

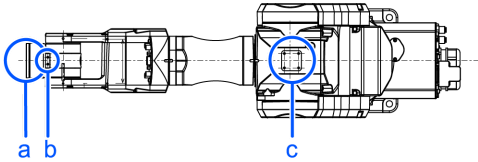

Symbol	Description
a	Load on the fore end of Arm #6
b	Arm #5 deck
c	Arm #3 deck

C4 series

Deck detailed

(Units: mm)

Arm #5 deck	Arm #3 deck

When you attach the equipment to the decks on the upper arm, convert its weight into equivalent weight assuming that the equipment is attached to the end of the Arm #6. Then, this equivalent weight added to the load will be a Weight parameter.

Calculate the Weight parameter by using the formula below and enter the value.

Weight Parameter Formula

Weight parameter = $M_w + W_a + W_b$

- M_w : Payload on the fore end of Arm #6 (kg)
- W_a : Equivalent weight of the Arm #3 deck (kg)
- W_b : Equivalent weight of the Arm #5 deck (kg)
- $W_a = M_a (L_a)^2 / (L)^2$
- $W_b = M_b (L_b)^2 / (L)^2$
- M_a : Weight of the air valve on the Arm #3 deck (kg)
- M_b : Weight of the camera on the Arm #5 deck (kg)
- L: Length of the upper arm (315 mm)
- L_a : Distance between the Joint #3 and the center of gravity of the air valve on the Arm #3 deck (mm)

- L_b : Distance between the Joint #3 and the center of gravity of the camera on the Arm #5 deck (mm)

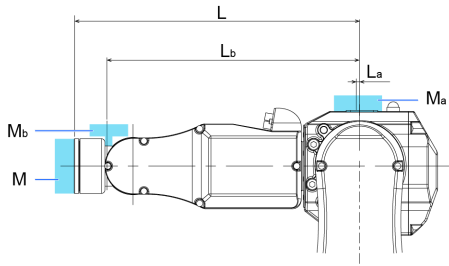

[Example]

When the following loads apply to C4 which fore end of the Arm #6 is 315 mm (L) away from the Joint #3 and payload (M_w) is 1 kg:

- Load on the Arm #3 deck is 1.5 kg (M_a). The deck is 0 mm (L_a) away from the Joint #3.
- Load on the Arm #5 deck is 0.5 kg (M_b). The deck is 280 mm (L_b) away from the Joint #3.

$$W_a = 1.5 \times 0^2 / 315^2 = 0$$

$$W_b = 0.5 \times 280^2 / 315^2 = 0.395 \rightarrow 0.4 \text{ (round up)}$$

$$M_w + W_a + W_b = 1 + 0 + 0.4 = 1.4$$

Enter "1.4" for the Weight parameter.

Automatic Speed Setting by Weight Parameter (C4-B601)**

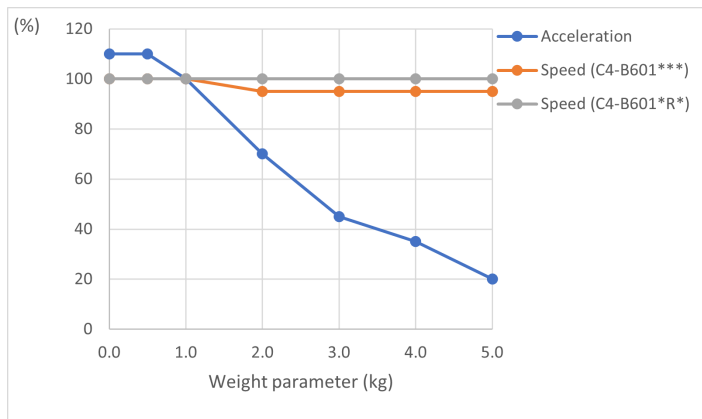

Automatic Speed Setting by Weight Parameter (C4-B901)**

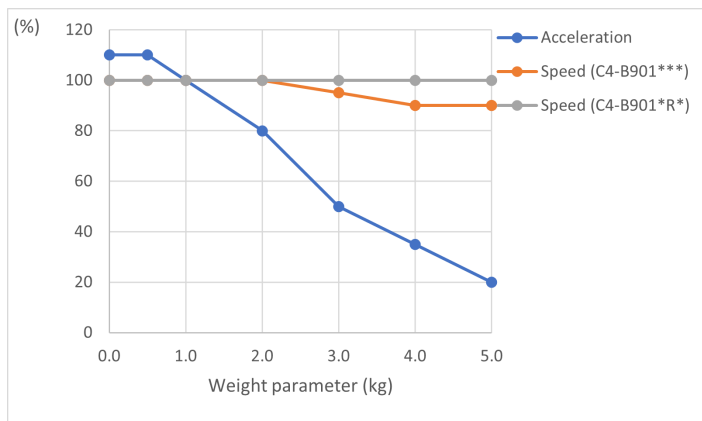

- The percentage in the graph is based on the speed at rated weight (1 kg) as 100%.

- If the payload exceeds the maximum payload, refer to the following section.
 "WEIGHT Setting - Restrictions on payload exceeding the maximum payload"

Restrictions on payload exceeding the maximum payload

Maximum payload for C4 Manipulators is as follows: Payload can be increased by restricting the arm posture of the Arm #5 downward.

Max. Payload	Max. Payload with Pose Restriction
4 kg	5 kg

If the load exceeds the maximum payload, use the Arm #5 with a posture angle within the range indicated in the following graph.

The graph shows the relation of the load weight and Arm #5 angle limit (A1) measured in vertical direction (direction of gravity). Note that the heavier the load on the Arm #6, the smaller the angle limit becomes.

When the Manipulator operates vertically to the operating surface, the limit of the Arm #5 is equivalent to the limit of the operating angle (A2).

In addition, for the eccentric load, the angle limit is an angle of the line joining the center of the load and the Arm #5 rotation axis with the vertical direction (B).

The eccentricity of the load should be within the allowable moment and moment of inertia of Arms #4, #5, and #6.

Relation of load weight and Arm #5 angle limit

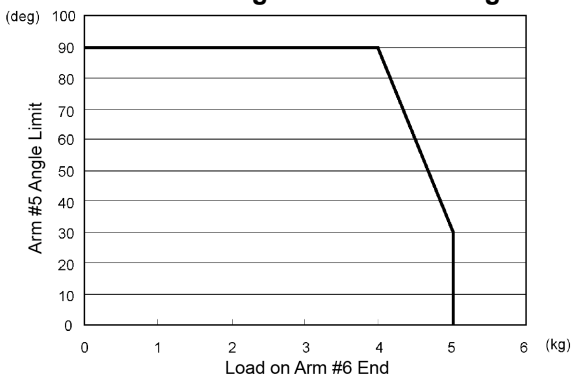

Relation of Arm #5 angle and operating surface

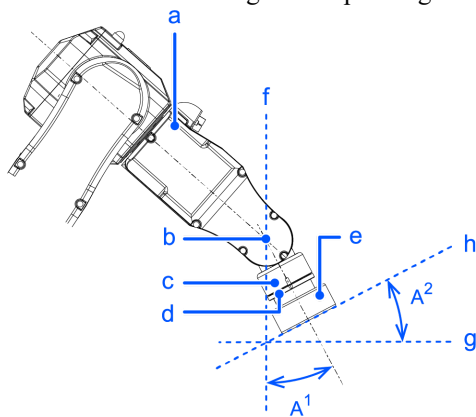

Symbol	Description
a	Arm #4
b	Arm #5 rotation axis
c	Arm #5

Symbol	Description
d	Arm #6
e	Load on the fore end of Arm #6
f	Vertical direction
g	Plane
h	Operating surface

Angle limit for eccentric load

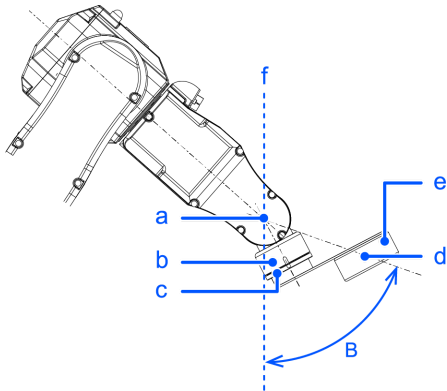

Symbol	Description
a	Arm #5 rotation axis
b	Arm #5
c	Arm #6
d	Center of gravity
e	Load on the fore end of Arm #6
f	Vertical direction

2.4.3.2 INERTIA Setting

Moment of Inertia and INERTIA Setting

The moment of inertia is a quantity that expresses how hard it is for an object to turn, and it is expressed in terms of values for the moment of inertia, inertia, or GD^2 . When a hand or other object is attached to the Arm #6 for operation, the moment of inertia of the load must be taken into consideration.

CAUTION

- The moment of inertia of the load (hand + workpiece) must be $0.1 \text{ kg}\cdot\text{m}^2$ or less.

The C4 Manipulators are not designed to work with a moment of inertia exceeding $0.1 \text{ kg}\cdot\text{m}^2$. Always set the value corresponding to the moment of inertia. Setting a parameter value that is smaller than the actual moment of inertia may cause errors or impact, may prevent the Manipulator from working at full functionality, and may shorten the lifespan of mechanical parts.

The allowable moment of inertia of a load for C4 Manipulators is $0.005 \text{ kg}\cdot\text{m}^2$ at the default rating and $0.1 \text{ kg}\cdot\text{m}^2$ at the maximum. When the moment of inertia of the load exceeds the rating, change the setting of the moment of inertia parameter for the load in the Inertia statement. After the setting is changed, the maximum acceleration/deceleration of Arm #6 that corresponds to the "Inertia" value is corrected automatically.

Moment of Inertia of Load Attached to Arm #6

The moment of inertia of the load (hand + workpiece) attached to the Arm #6 can be set by the "Inertia" parameter in the Inertia statement.



Go to [Tools] - [Robot Manager] - [Inertia] panel, and enter the value in [Inertia]. This can also be set using the Inertia statement in [Command Window].

Eccentricity and INERTIA Setting

⚠ CAUTION

- The eccentricity of the load (hand + workpiece) must be 200 mm or less. The C4 Manipulators are not designed to work with eccentricities exceeding 200 mm. Always set the value based on the eccentricity. Setting the eccentricity parameter to a value smaller than the actual eccentricity may cause errors or impact that not only impair full functionality but also shorten the life of the mechanical components.

The allowable eccentricity of load for C4 Manipulators is 30 mm at the default rating and 200 mm at the maximum. When the load eccentricity exceeds the rating, change the setting for the eccentricity parameter in Inertia statement. After the setting is changed, the maximum acceleration/deceleration of the Manipulator that corresponds to the "Eccentricity" is corrected automatically.

Eccentricity

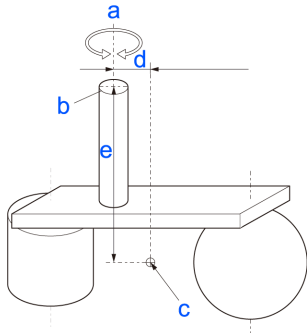

Symbol	Description
a	Rotation axis
b	Flange
c	Load center of gravity position
d, e	Eccentricity (200 mm or less) To set the parameter, enter the larger value of "d" or "e".

Eccentricity of Load Attached to Arm #6

The eccentricity of the load (hand + workpiece) attached to the Arm #6 can be set by the "Eccentricity" parameter in the Inertia statement.

Enter the larger value of either "d" or "e" in the figure above to [Eccentricity].



Go to [Tools] - [Robot Manager] - [Inertia] panel, and enter the value in [Eccentricity]. This can also be set using the Inertia statement in [Command Window].

Automatic Acceleration/Deceleration Correction at INERTIA (Eccentricity) Setting

Automatic setting by inertia moment setting

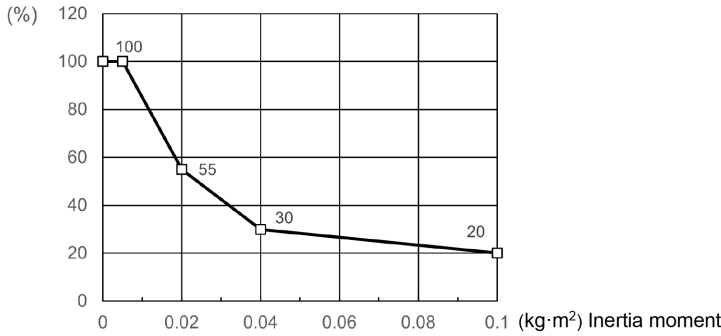

* The percentages on the graph are ratios based on 100% as the acceleration/deceleration at the rated (0.005 kg·m²) setting.

Automatic setting by eccentricity setting

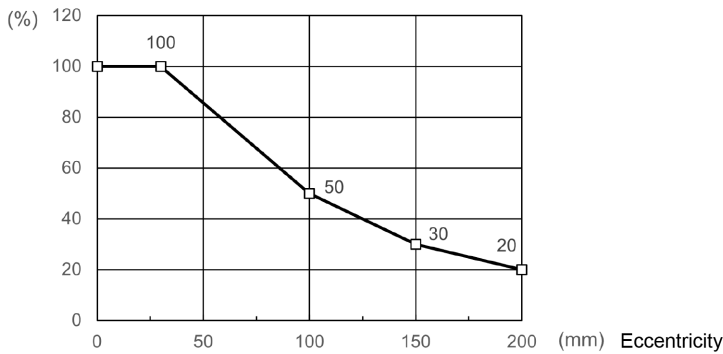

* The percentages on the graph are ratios based on 100% as the acceleration/deceleration at the rated (30 mm) setting.

INERTIA (eccentricity) is affected by the load setting. Refer to the following section and configure the load setting carefully.

[WEIGHT and INERTIA Settings](#)

Calculating the Moment of Inertia

An example of calculating the moment of inertia of a load (hand holding a workpiece) is shown below.

The moment of inertia of the entire load is calculated by the sum of (A), (B), and (C).

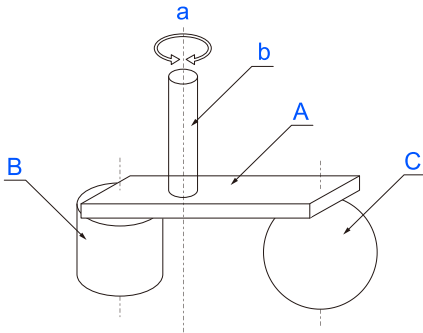

$$\text{Whole moment of inertia} = \text{Moment of inertia of end effector (A)} + \text{Moment of inertia of work piece (B)} + \text{Moment of inertia of work piece (C)}$$

Symbol	Description
a	Rotation axis
b	Shaft
A	Hand
B	Workpiece
C	Workpiece

The methods for calculating the moment of inertia for (A), (B), and (C) are shown below. Use the moment of inertia of these basic shapes as a reference to find the moment of inertia of the entire load.

(A) Moment of inertia of a rectangular parallelepiped

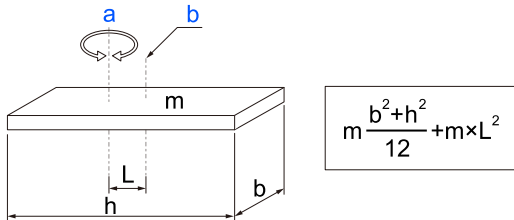

Symbol	Description
a	Rotation axis
b	Center of gravity of rectangular parallelepiped
m	Weight

(B) Moment of inertia of a cylinder

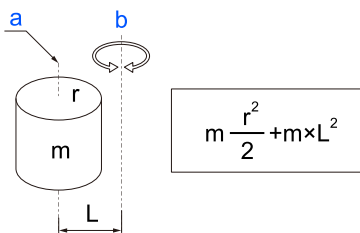

Symbol	Description
a	Center of gravity of cylinder

Symbol	Description
b	Rotation axis
m	Weight

(C) Moment of inertia of a sphere

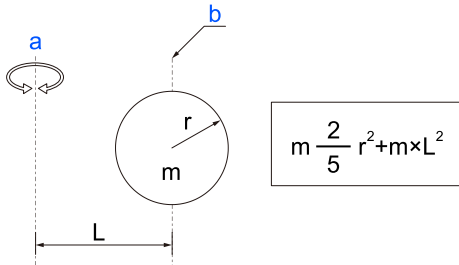

Symbol	Description
a	Rotation axis
b	Center of gravity of sphere
m	Weight

2.4.4 Safety Information for Auto Acceleration

The speed and acceleration/deceleration of the Manipulator motion are automatically optimized according to the values of WEIGHT and INERTIA and the Manipulator’s postures.

WEIGHT Setting

The speed and acceleration/deceleration of the Manipulator are controlled according to the load weight set by the WEIGHT command. The more the load weight increases, the more the speed and acceleration/deceleration are reduced to prevent residual vibration.

INERTIA Setting

The acceleration/deceleration of Arm #6 are controlled according to the inertia moment set by the INERTIA command. The acceleration/deceleration of the whole Manipulator are controlled according to the eccentricity set by the INERTIA command. The more the inertia moment and eccentricity of the load increase, the more the acceleration/ deceleration are reduced.

Auto Acceleration/Deceleration According to Manipulator’s Posture

The acceleration/deceleration are controlled according to the Manipulator’s posture. When the Manipulator extends its arms or when the movement of the Manipulator produces vibration frequently, the acceleration/deceleration are reduced.

Set appropriate values for WEIGHT and INERTIA so that the Manipulator operation is optimized.

2.5 Work Envelope

⚠ WARNING

- Do not operate the Manipulator with the mechanical stop removed. Removing the mechanical stop is extremely dangerous because the Manipulator may move to a position outside its normal work envelope.

⚠ CAUTION

- When restricting the work envelope for safety reasons, be sure to make settings using both the pulse range and mechanical stop.

The work envelope is preset at the factory as explained in the following section. This is the maximum work envelope of the Manipulator.

Standard Work Envelope

The work envelope can be set by one of the following three methods.

- Setting by pulse range (for each joint)
- Setting by mechanical stops
- Setting the rectangular range in the XY coordinate system of the Manipulator

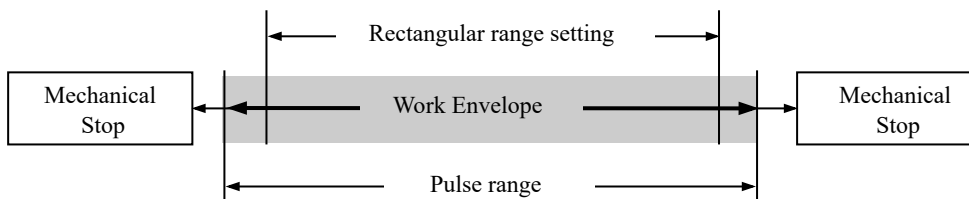

To limit the work envelope for layout efficiency or safety reasons, make the settings as explained in the following sections.

- Work Envelope Setting by Pulse Range (for Each Joint)**
- Setting the Work Envelope by Mechanical Stops**
- Restriction of Manipulator Operation by Joint Angle Combination**
- Coordinate System**

2.5.1 Work Envelope Setting by Pulse Range (for Each Joint)

Pulses are the basic unit of Manipulator motion. The motion range (work envelope) of the Manipulator is set by the pulse lower limit value and pulse upper limit value (pulse range) for each joint. Pulse values are read from the encoder output of the servomotor.

Be sure to set the pulse range within the mechanical stop range.

⚠ CAUTION

- Do not set and/or use the Arm #4 with a pulse range exceeding the maximum value. The Arm #4 does not have a mechanical stop. Using the Arm #4 with a pulse range exceeding the maximum pulse range may cause the inner wiring damaged and/or malfunction to the Manipulator.

Torsion of the inner wiring can be checked by removing the Arm #3 head cover.

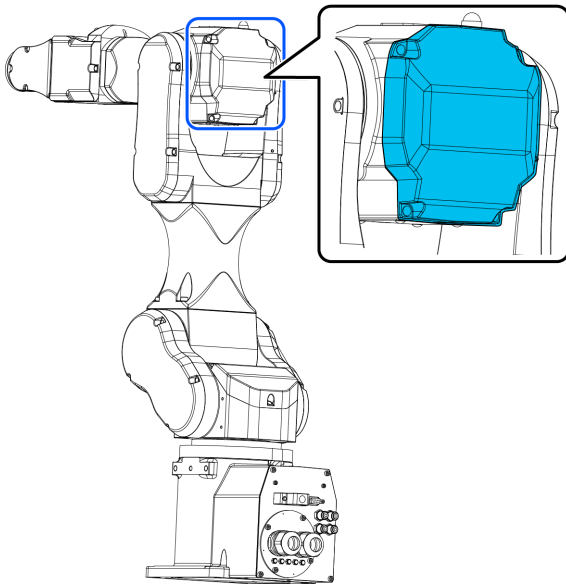

KEY POINTS

Once the Manipulator receives a motion command, it checks whether the target position specified by the command is within the pulse range before operating. If the target position is outside of the pulse range that was set, an error occurs and the Manipulator does not move.

Epson
RC+

Go to [Tools] - [Robot Manager] - [Range] panel, and make the setting. This can also be set using the Range statement in [Command Window].

2.5.1.1 Arm #1 Maximum Pulse Range

With the 0 pulse as a starting point, the counterclockwise pulse value is defined as positive (+), and the clockwise pulse value is defined as negative (-).

C4-B601**

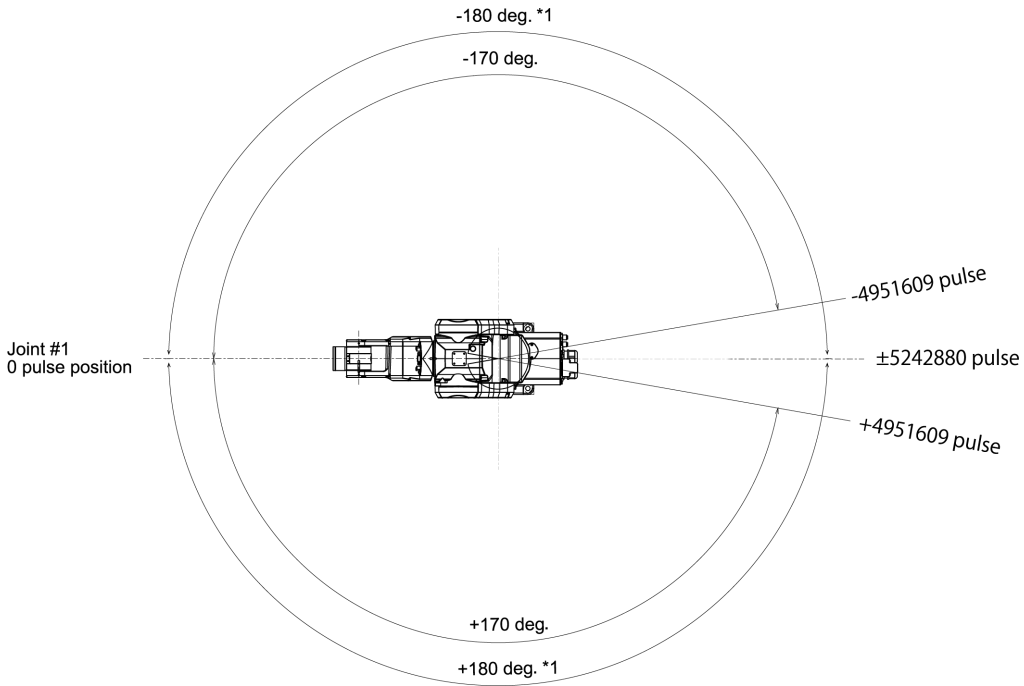

*1 Software limit maximum value

C4-B901**

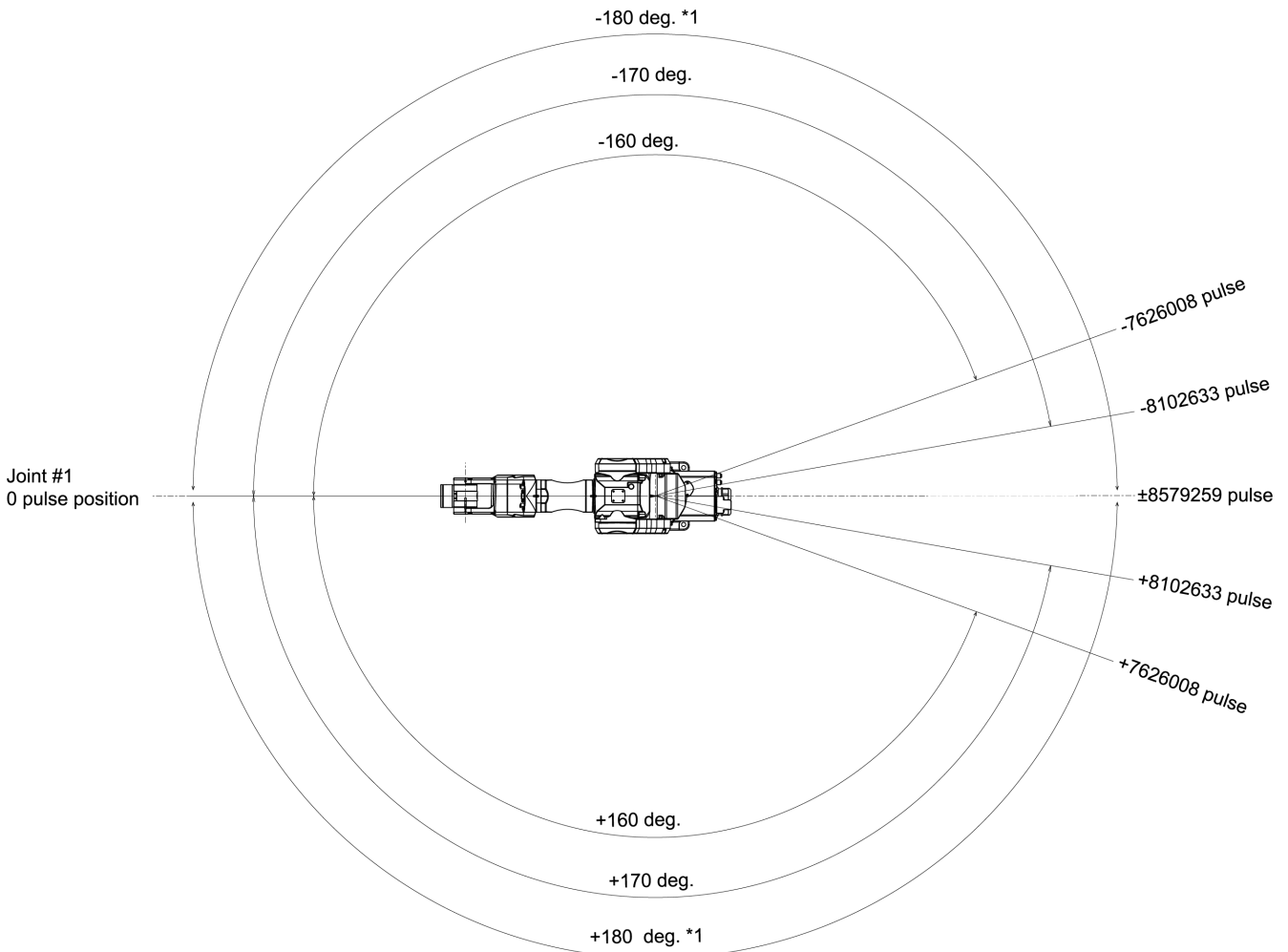

*1 Software limit maximum value

2.5.1.2 Arm #2 Maximum Pulse Range

With the 0 pulse as a starting point, the clockwise pulse value is defined as positive (+), and the counterclockwise pulse value is defined as negative (-).

C4-B601**

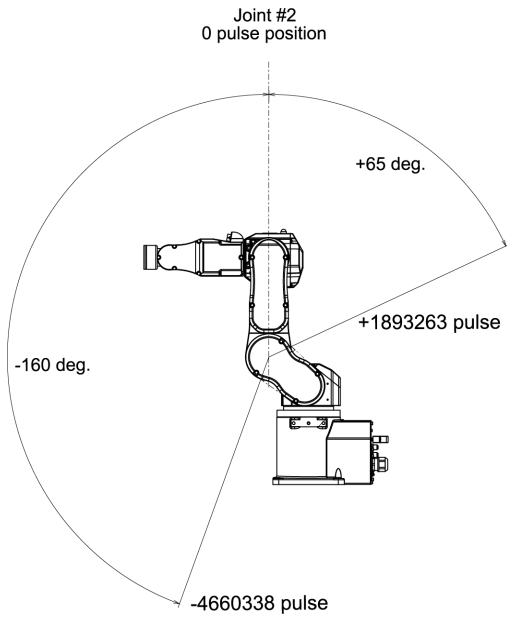

C4-B901**

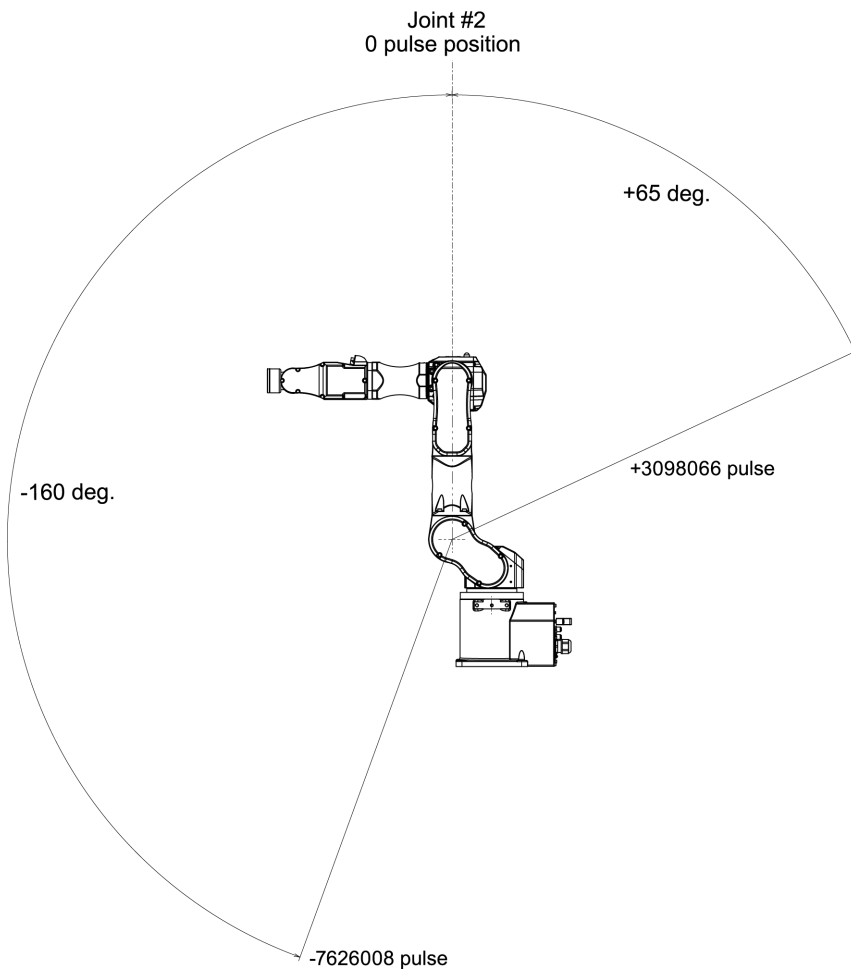

2.5.1.3 Arm #3 Maximum Pulse Range

With the 0 pulse as a starting point, the clockwise pulse value is defined as positive (+), and the counterclockwise pulse value is defined as negative (-).

C4-B601**

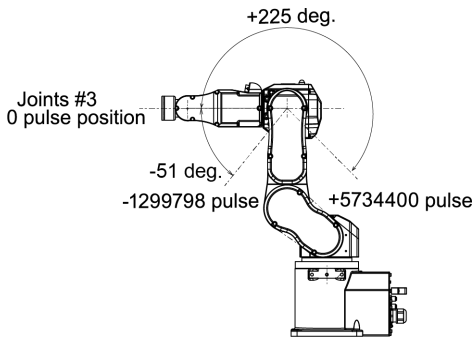

C4-B901**

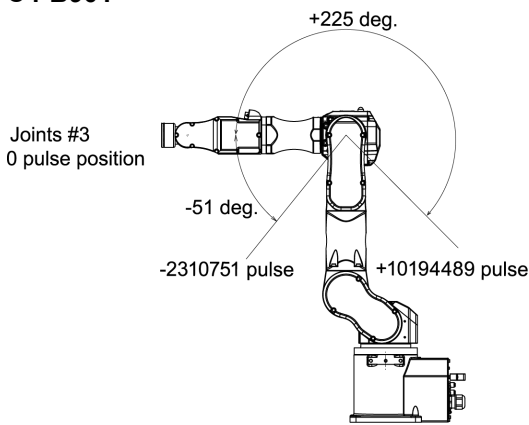

2.5.1.4 Arm #4 Maximum Pulse Range

From the angle of arm end, with the 0 pulse as a starting point, the clockwise pulse value is defined as positive (+), and the counterclockwise pulse value is defined as negative (-).

C4-B601**

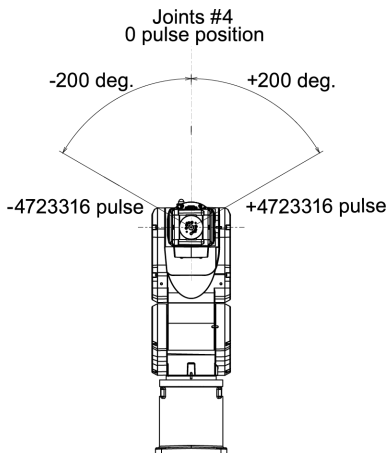

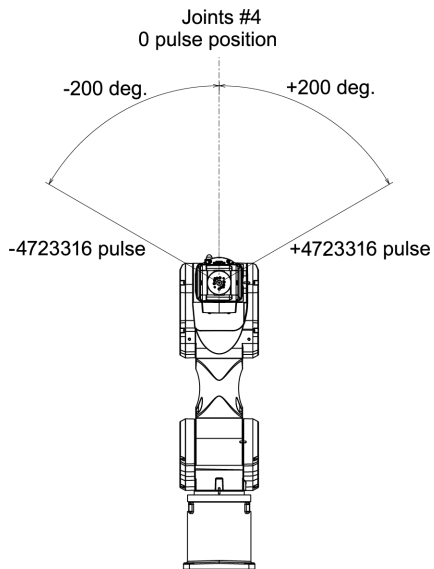
C4-B901****⚠ CAUTION**

- Do not set and/or use the Arm #4 with a pulse range exceeding the maximum value. The Arm #4 does not have a mechanical stop. Using the Arm #4 with a pulse range exceeding the maximum pulse range may cause the inner wiring damaged and/or malfunction to the Manipulator.

Torsion of the inner wiring can be checked by removing the Arm #3 head cover.

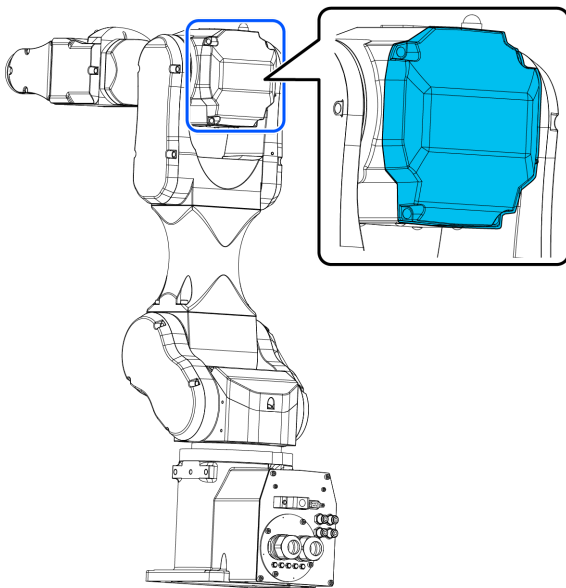
**2.5.1.5 Arm #5 Maximum Pulse Range**

With the 0 pulse as a starting point, the clockwise pulse value is defined as positive (+), and the counterclockwise pulse value is defined as negative (-).

C4-B601**

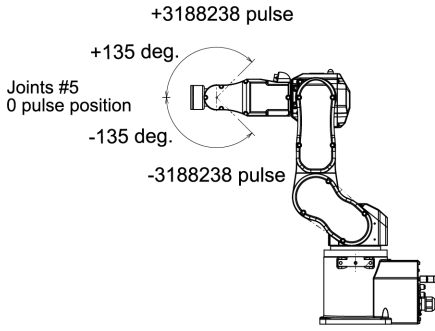

C4-B901**

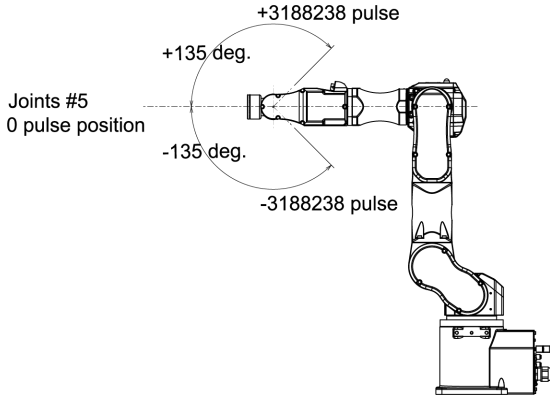

2.5.1.6 Arm #6 Maximum Pulse Range

From the angle of arm end, with the 0 pulse as a starting point, the clockwise pulse value is defined as positive (+), and the counterclockwise pulse value is defined as negative (-).

C4-B601**

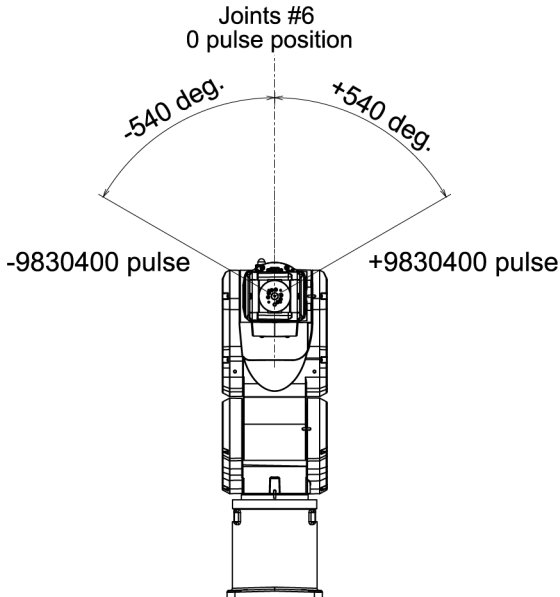

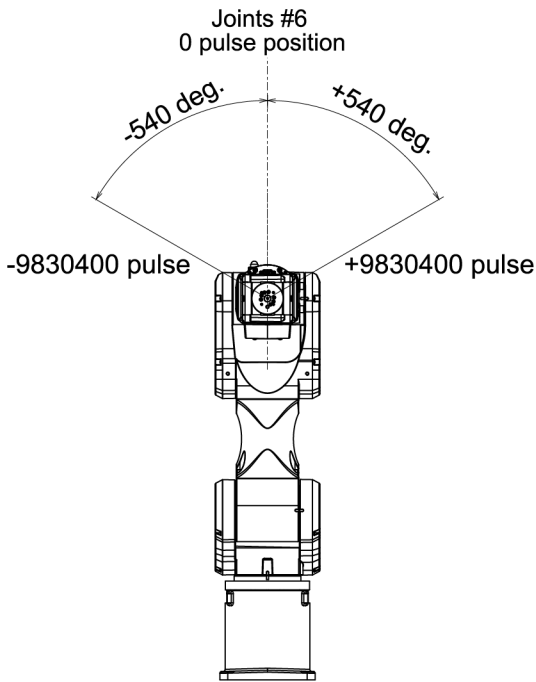
C4-B901**

2.5.2 Setting the Work Envelope by Mechanical Stops

Mechanical stops set the absolute work envelope that physically limits where the Manipulator can move.

Before starting any work, be sure to turn off the Controller.

Use bolts conforming to the specified length and surface processing (ex: nickel plating) with high corrosion resistance.

Specify the pulse range again after changing the position of the mechanical stop.

For details on the pulse range setting, refer to the following section.

[Work Envelope Setting by Pulse Range \(for Each Joint\)](#)

Be sure to set the pulse range inside the positions of the mechanical stop range.

2.5.2.1 Setting the Arm #1 Work Envelope

Install variable mechanical stop (J1) in the threaded holes corresponding to the angles to be set.

Normally a mechanical stop is not equipped.

- Hexagon socket head cap bolt: M8×15
- Strength: Compliant with ISO 898-1 property class: 10.9 or 12.9
- Tightening torque: 32.0 N·m (326 kgf·cm)

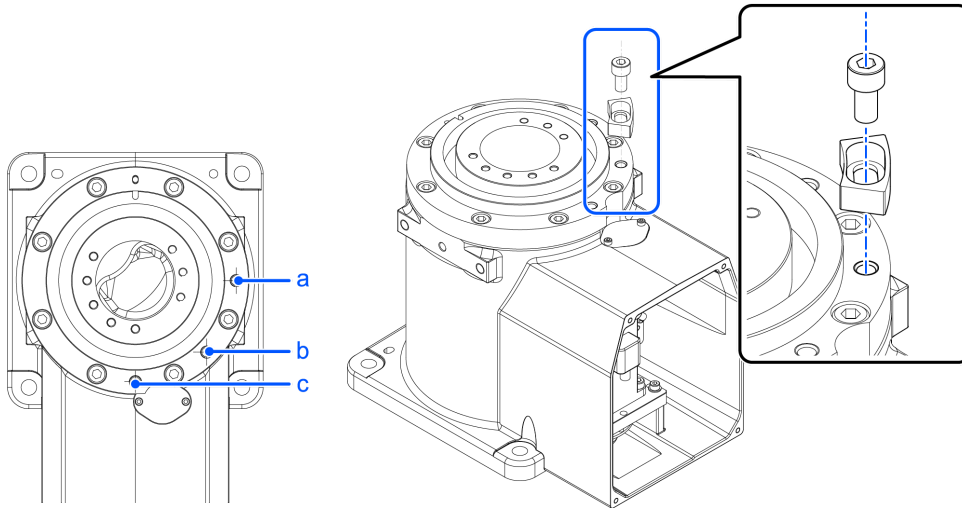

		a	b		c
Angle (°)		-115, +170	±160	±170	-170, +115
Pulse	C4-B601 **	-3640889, +4951609	±4660338	±4951609	-4951609, +3640889
	C4-B901 **	-5957819, +8102633	±76260083	±8102633	-8102633, +5957819
Variable Mechanical Stop (J1)		Applied	Applied	Not applied (standard)	Applied

2.5.2.2 Setting the Arm #2 Work Envelope

Attach the variable mechanical stop (J2) to Arm #1. Adhesive tape is attached to the variable mechanical stop (J2).

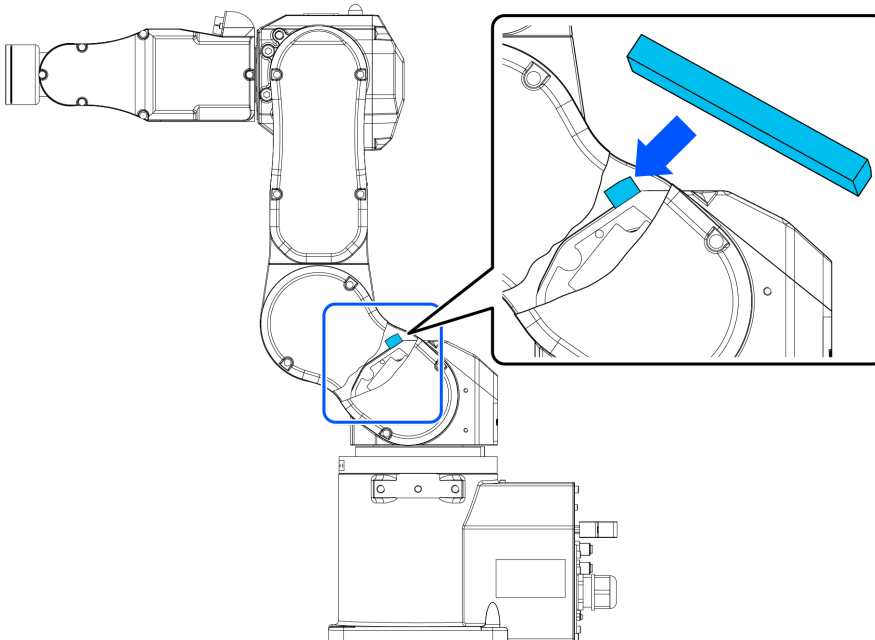

Angle (°)		-160, +65	-160, +55
Pulse	C4-B601 **	-4660338, +1893263	-4660338, +1601992
	C4-B901 **	-7626008, +3098066	-7626008, +2621440
Variable Mechanical Stop (J2)		Not applied (standard)	Applied

For C4-A901**, please contact the supplier.

2.5.2.3 Setting the Arm #3 Work Envelope

Install the bolts in the threaded holes corresponding to the angles to be set.

Normally mechanical stops are equipped on the position f and g. (+225~-51°)

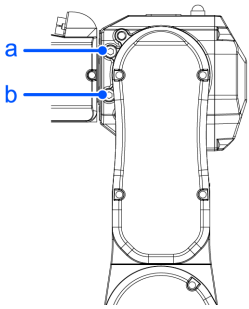

C4-B601**, C4-B901**

- Hexagon socket head cap bolt: M8×12
- Strength: Compliant with ISO 898-1 property class: 10.9 or 12.9
- Tightening torque: 32.0 N·m (326 kgf·cm)

		a	b
Angle (°)		+225	-51
Pulse	C4-B601 **	+5734400	-1299798
	C4-B901 **	+10194489	-2310751
Bolt		Applied (standard)	Applied (standard)

2.5.3 Restriction of Manipulator Operation by Joint Angle Combination

To prevent the arms of the Manipulator from interfering each other, the Manipulator operation is restricted in the specified motion range according to the angle combination of the Joint #1, #2, and #3.

The Manipulator operation is restricted and the Manipulator stops when the joint angles are within the colored areas in the following figure.

The restriction to Manipulator operation is enabled:

- During CP motion command execution
- When you attempt to execute the motion command for moving the Manipulator to a target point (or pose) in the specified motion range.

The restriction to the Manipulator operation is disabled:

- The Arms of the Manipulator momentarily go through the specified motion range during the PTP motion command execution even though the joint angles of the Arms are in the colored areas of the figures above.

(deg.=°)

Combination of Joint #1 and #2 (C4-B601)**

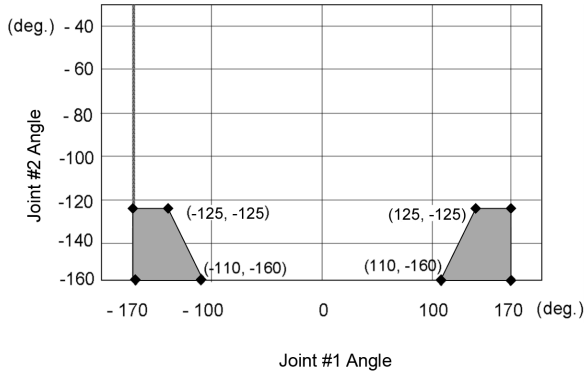

Combination of Joint #2 and #3 (C4-B601)**

- -135 deg. <= J1 <= 135 deg.

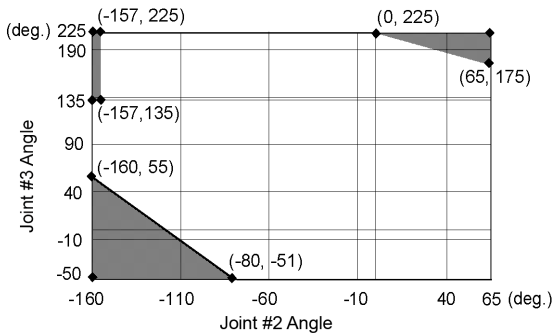

- -170 deg. <= J1 < -135 deg., 135 deg. < J1 <= 170 deg.

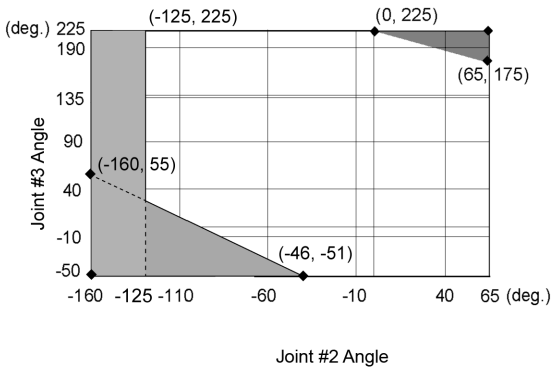

Combination of Joint #1 and #2 (C4-B901)**

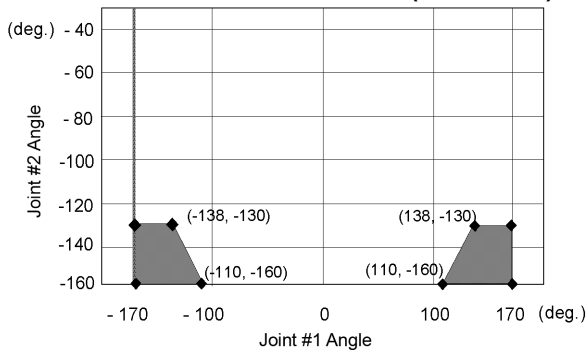

Combination of Joint #2 and #3 (C4-B901)**

- 138 deg. <= J1 <= 138 deg.

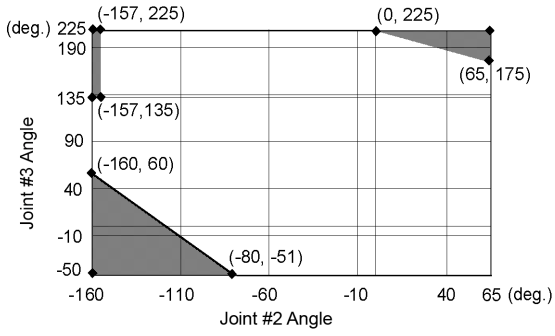

- 170 deg. <= J1 < -138 deg., 138 deg. < J1 <= 170 deg.

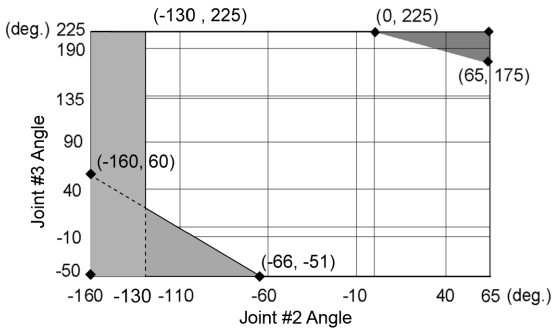

2.5.4 Coordinate System

The origin point is where the Manipulator’s installation face intersects with the rotation axis of Joint #1.

For details on the coordinate system, refer to the Epson RC+ Users Guide manual.

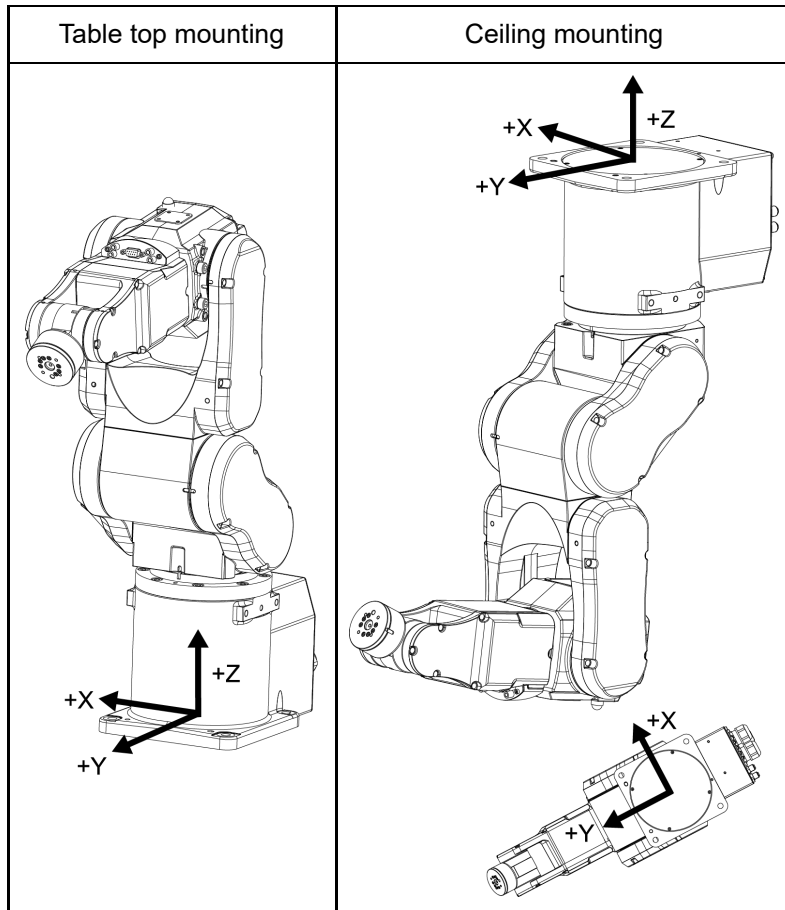

BASE setting is suitable for install the robot obliquely.

BASE setting can change a specific coordinate system of the robot and match the World coordinate system of the Jog & Teach and the coordinate system of the equipment.

For procedure of the BASE setting, refer to SPEL+ Language Reference: BASE Command.

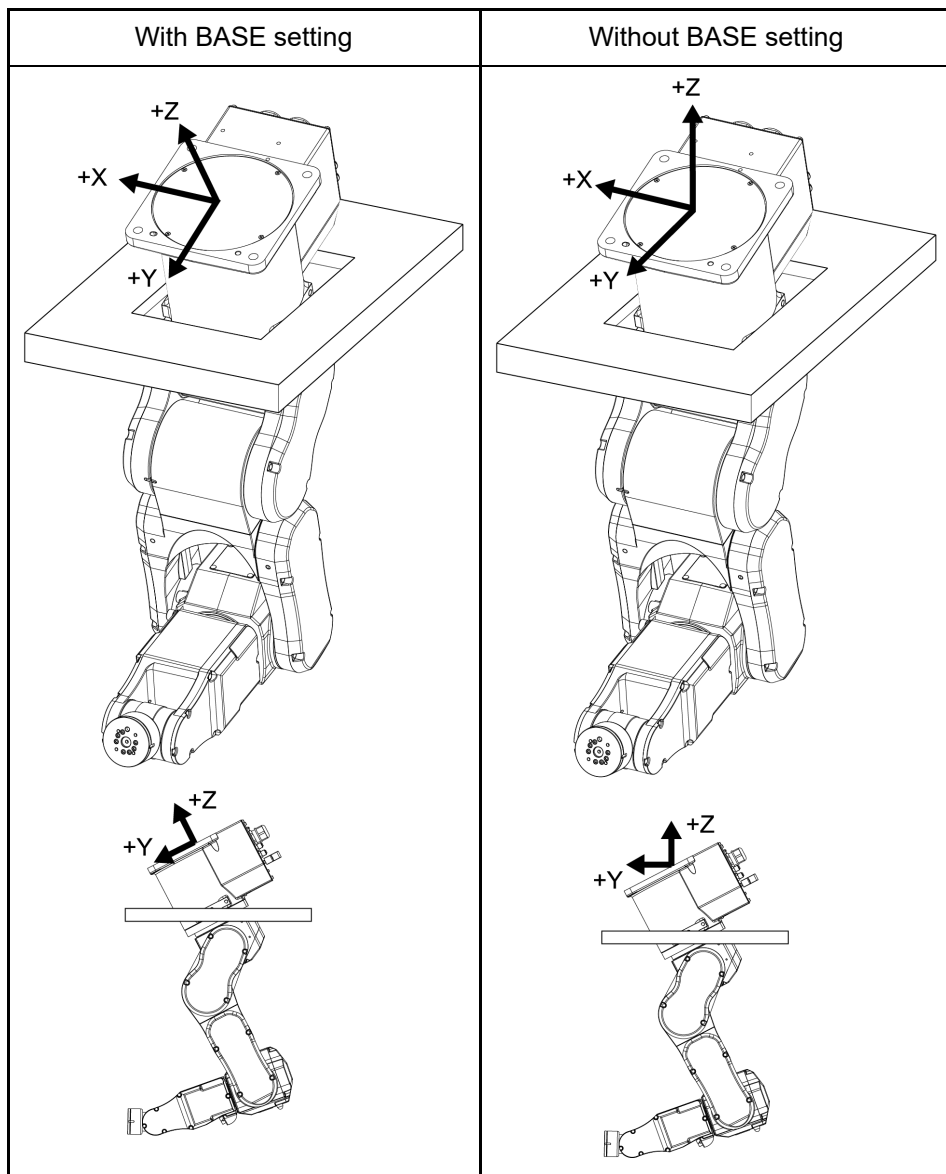

2.5.5 Changing the Robot

This section describes how to change the Manipulator model on Epson RC+.

(Default setting is "table top mounting".)

CAUTION

Changing the Manipulator should be done with great caution. It initializes the robot calibration parameters (Hofs, CalPIs), additional axis information, and PG parameter data. Before changing the robot, make sure to save the calibration data by following the procedure below.

1. Select the Epson RC+ menu-[Setup]-[System Configuration].
2. Select [Controller]-[Robots]-[Robot**]-[Calibration] from the tree list. Then, click [Save].

1. Select the Epson RC+ menu-[Setup]-[System Configuration].
2. Select [Controller]-[Robots]-[Robot**] from the tree list. (Dialog image: Epson RC+ 8.0)

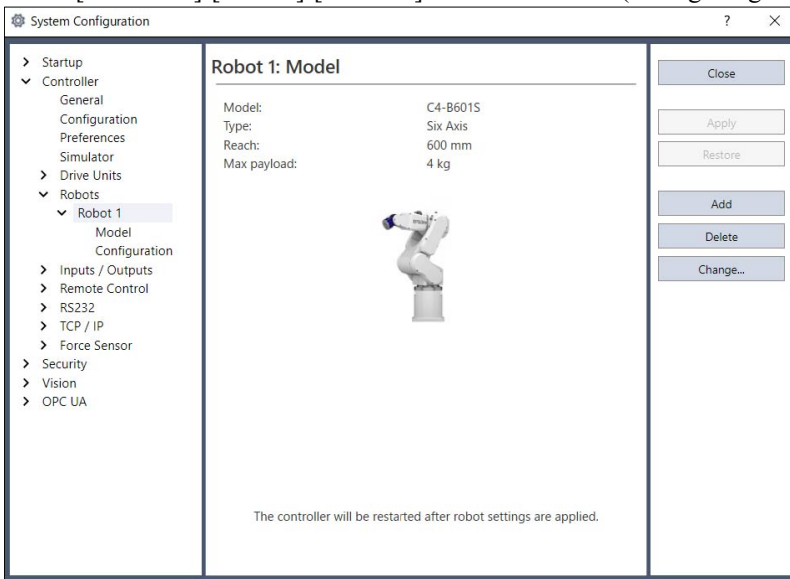

3. Click the [Change] button. The following dialog box will be displayed.

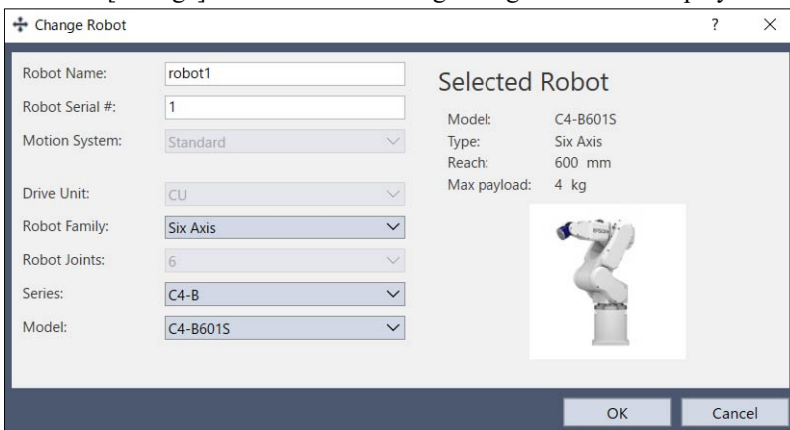

4. Input the robot name and serial number printed on the name plate of the Manipulator. Any serial number can be entered. However, enter the number printed on the Manipulator.
5. Select the robot type in the [Robot type] box.
6. Select the series name of the Manipulator in the [Series] box.
7. Select the robot model in the [Model] box.

Available robots will be displayed according to the format of the currently installed motor driver. When [Dry run] is used, all the Manipulators of the series selected in Step 6 will be displayed. For the ceiling mount type, select the model which ends with "R" (e.g. C4-B601SR).

8. Click the [OK] button. The Controller is restarted.

2.5.6 Setting the Rectangular Range in the XY Coordinate System of the Manipulator

The Cartesian (rectangular) range in the XY coordinate system of the Manipulator is specified by the limited Manipulator operation area and the XYLIM setting. The limited Manipulator operation area is defined so that the hand does not interfere with the rear side of the Manipulator. The XYLIM setting that you can determine the upper and lower limits of the X and Y coordinates.

These settings are software-based limit, and so it does not change the maximum physical range. The maximum physical range is based on the position of the mechanical stops.

These settings are disabled during a joint jogging operation. Therefore, be careful not to allow the hand to collide with the Manipulator or peripheral equipment.

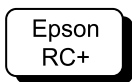

Go to [Tools] - [Robot Manager] - [XYZ Limits] panel, and make the setting. This can also be set using the XYLim statement in [Command Window].

2.6 Options

C4 series Manipulator has the following options.

- **Brake Release Unit**
- **Camera Plate Unit**
- **PS Compatible Plate (Tool Adapter)**
- **Base Side Angled Fittings**
- **Base Side Fittings**
- **PS Compatible Plate (Base Adapter)**
- **Variable Mechanical Stop**

2.6.1 Brake Release Unit

While the electromagnetic brake is on (such as in emergency mode), you cannot move any arm by pushing manually. You can move the Arms by hand using the brake release unit while the Controller power is off or right after unpacking.

KEY POINTS

Precautions regarding the brake release unit

- Be sure to prepare at least one set of the brake release unit.
- Place at easy-to-reach location so that you can use it immediately when in a emergency situation.

WARNING

- Turn off the power to the Robot Controller and brake release unit when connecting or replacing the brake release unit or external short connector. Inserting or removing connectors with the power on may result in electric shock and/or malfunction of the robot system.

CAUTION

- Normally, release the brakes of joints one at a time. If the brakes of two or more joints must be released simultaneously due to unavoidable reasons, use extreme care. Releasing the brakes of multiple joints simultaneously may cause the arm to fall in an unexpected direction, resulting in hands or fingers getting caught or damage or failure of the Manipulator.
- After releasing the brake, the arm may fall by its own weight or move to the unexpected direction. Make sure to prepare a countermeasure to prevent the arm from falling and check the operation environment is safe.

Width	180 mm
Depth	150 mm
Height	87 mm
Weight (Cables are not included.)	1.7 kg
Cable to the Manipulator	2 m

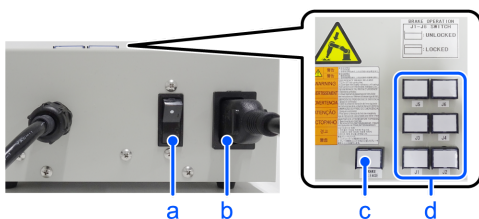

Symbol	Description
a	Power switch
b	Power Cable (You must provide.)
c	Power lamp
d	Brake release switch

2.6.1.1 Power Cable

You must provide a power cable. Be sure to use the specifications below.

Symbol	Item	Specifications
a	Plug	<p>Comply with local safety regulation</p> <ul style="list-style-type: none"> Class I (2P + PE), AC250 V, 6 A or 10 A Ex.: CEE Pub.7 Certified, CCC Certified, KC Certified, BS1363 Certified, PSB Certified, BIS Certified, SABS Certified Class I (2P + PE), AC125 V, 7 A, 12 A, or 15 A etc. Ex.: UL Certified, PSE Certified, BSMI Certified
b	Flexible cable	<p>Comply with IEC/EN standards or local safety regulation</p> <p>Example:</p> <ul style="list-style-type: none"> IEC 60227-1: General requirements IEC 60227-5: Polyvinyl chloride insulated cables of rated voltages up to and including 450/750 V - Part 5: Flexible cables (cords) EN 50525-1: General requirements EN 50525-2-11: Electric cables - Low voltage energy cables of rated voltages up to and including 450/750 V (Uo/U) - Part 2-11: Cables for general applications - Flexible cables with thermoplastic PVC insulation
c	Appliance coupler	<p>Comply with IEC/EN standards or local safety regulation</p> <ul style="list-style-type: none"> IEC / EN 60320-1: Appliance couplers for household and similar general purposes - Part 1: General requirements Standard Sheet C13: AC250 V/10 A

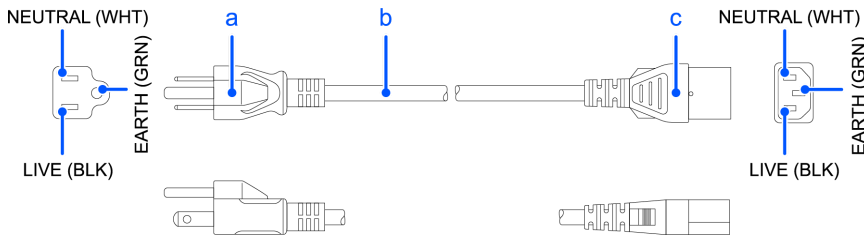

For Japan

Item	Specifications
Plug	PSE Certified Class I (2P+PE), AC125 V, 7 A or higher
Code	PSE Certified 0.75 mm ² or more
Connector	PSE Certified IEC 60320-1 Standard Sheet C13: AC125 V/10 A or higher

Precautions for use

⚠ CAUTION

- Operating the Manipulator without a brake release unit or external short connector connected may cause the brake to fail to release, possibly damaging the brake.
After using the brake release unit, be sure to connect the external short circuit connector to the Manipulator or make sure to leave the connector for the brake release unit connected.
- Keep the external short connector. Otherwise you cannot release the brakes.
- If you turn on the brake release unit while the brake release switch is being pressed, an unintended arm may move downward. Before turning on the brake release unit, make sure that the brake release switch is not pressed.
- If you turn on the brake release unit without the connector, it may lead to the short for the male pin used in the connector. Before turning on the brake release unit, make sure that the connector is connected.

2.6.1.2 Installing the Brake Release Unit

1. Turn off the Controller.
2. Remove the external short connector.



3. Connect the brake release unit to the connector of the connection cable.



2.6.1.3 Removing the Brake Release Unit

1. Turn off the brake release unit.
2. Remove the power cable of the brake release unit.

3. Disconnect the brake release unit from the connector of the connection cable.
4. Connect the external short connector to the connector of the connection cable.

2.6.1.4 How to Use the Brake Release Unit

⚠ CAUTION

- After releasing the brake, the arm may fall by its own weight or move to the unexpected direction. Make sure to prepare a countermeasure to prevent the arm from falling and check the operation environment is safe.
- If the arm you released its brake moves awkwardly or faster than usual, stop the operation promptly and contact the supplier. The brake release unit may be broken. If you keep operating the Manipulator, it may lead to the breakdown of the Manipulator or you may get your hand or fingers caught.

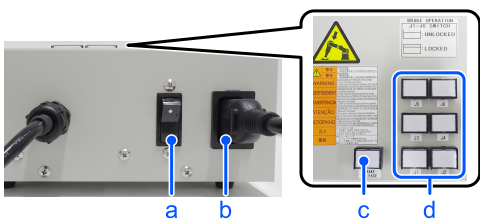

Symbol	Description
a	Power switch
b	Power cable (You must provide.)
c	Power lamp
d	Brake release switch

1. Refer to “Installing the Brake Release Unit” above to connect the brake release unit to the connector of the connection cable.
2. Plug the power cable into the brake release unit.
3. Plug the power cable into the power supply plug.
4. Turn on the brake release unit. When the brake release unit is enabled, the power lamp lights up.
5. Press the switch of the arm (J1 to J6) you want to move and then move the arm. Press the switch again. The brake will be released. The brake will be enabled by pressing the switch once again.

✍ KEY POINTS

Move the arm the brake is released by two persons or more (one presses the switch and one moves the arm). The arm can be very heavy and needs the significant force to move.

2.6.2 Camera Plate Unit

To mount a camera to the C4 series Manipulator, you need to mount the camera plate unit first.

Appearance of arm end with camera

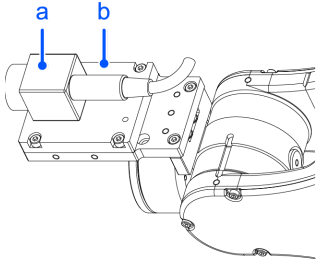

Symbol	Description
a	Camera
b	Camera Plate Unit

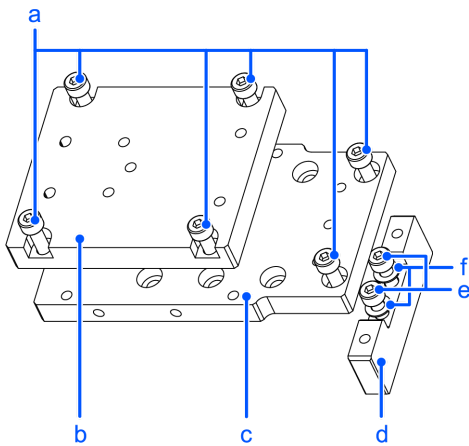

Parts Included		Qty.
a	Hexagon socket head cap bolt M4×12	6
b	Camera adapter plate	1
c	Camera mid plate	1
d	Camera base plate	1
e	Hexagon socket head cap bolt M4×20	2
f	Plain washer for M4 (small washer)	2

Installation

KEY POINTS

For details of tightening the hexagon socket head cap bolt, refer to the following section.

Tightening the Hexagon Socket Head Cap Bolts

1. Mount the camera base plate to the Manipulator.
2×M4×20 + plain washer for M4 (small washer)

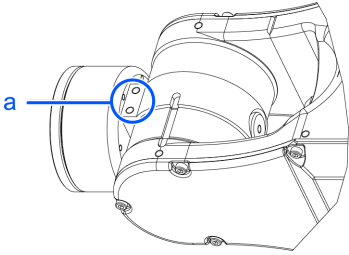

Symbol	Description
a	Mounting holes for the camera base plate

2. Mount the camera mid plate to the base plate.
2×M4×12

KEY POINTS

The motion range and dimension of the Manipulator with the camera installed may vary depending on the mounting hole of camera mid plate. The details are described in the table below.

3. Mount the camera to the camera adapter plate.

KEY POINTS

According to the camera, the available mounting hole of adapter plate will be different. The details are described below.

4. Mount the camera adapter plate and camera to the camera mid plate.
4×M4×12
5. Secure the cables at the position where they do not interfere with the Manipulator motion.

KEY POINTS

When securing the cables, check if the cables bend radius is big enough and the cables are not rubbing against each other while the Manipulator moves. Otherwise, the cables will be disconnected.

Dimension of the camera plate unit

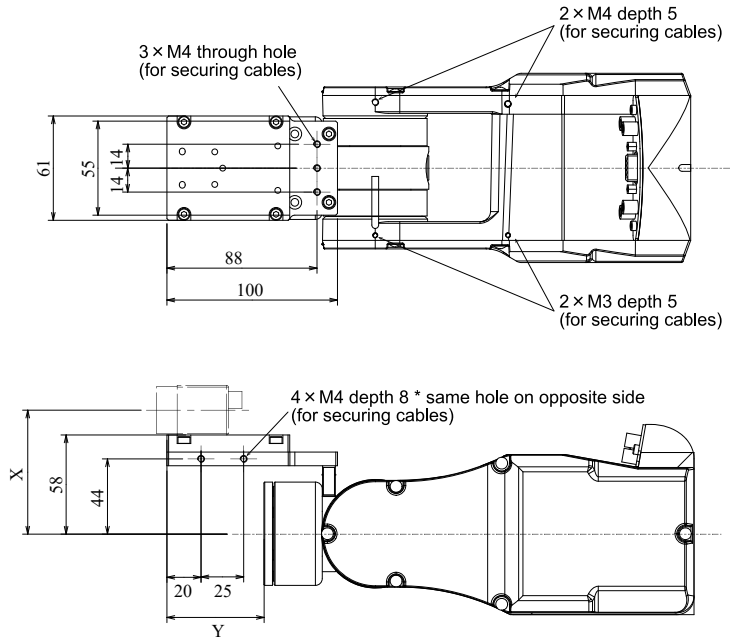

Dimensions X and Y will change depending on the position of camera mid plate and camera size. Refer to the table below for the values.

Camera mid plate

The camera mid plate uses the mounting holes A to D.

By using the different mounting holes, it can be mounted to the camera base plate in the different four positions.

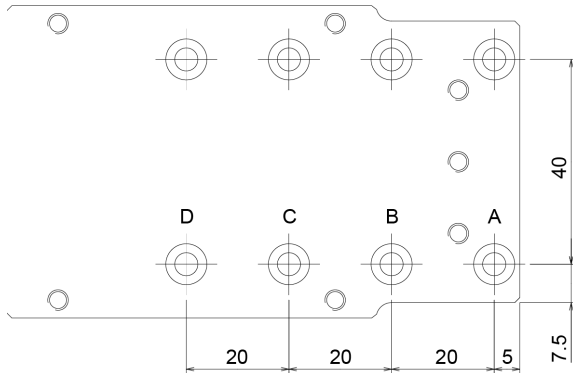

Camera adapter plate

Each camera uses the different mounting holes.

- USB camera: J (2 holes)
- GigE camera: E (3 holes)

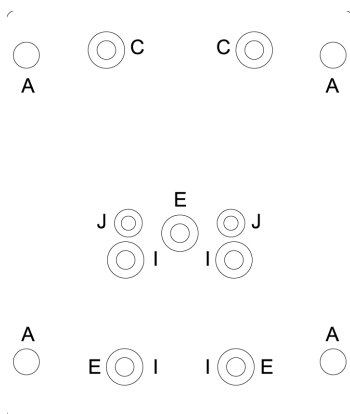

Mounting example

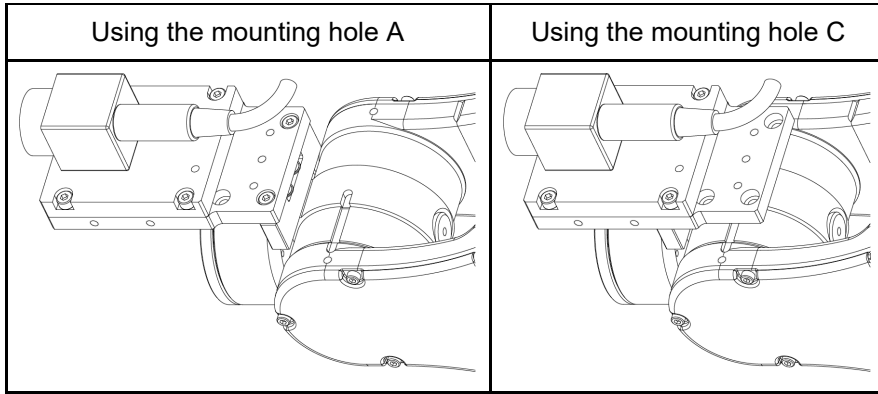

E.g.) Camera: XC-ES30

Camera and Joint #5 motion range (reference values)

The Joint #5 motion range varies depending on the mounting position of camera mid plate and the camera you are using.

The table below shows the motion range (reference values) based on the available cameras for this option and the mounting positions of the camera mid plate. The values in the table may vary depending on how to secure the cables.

By changing the Y position, you can extend the distance from the hand mounting surface to the camera. Also, you can attach the larger end effector. However, be careful about the Joint #5 motion range that will be limited in this case.

(°= deg.)

	A	B	C	D	X
USB Camera, GigE Camera	-135° to +60°	-135° to +50°	-135° to +35°	-135° to +25°	72.5 mm

	A	B	C	D
Y	57 mm	37 mm	17 mm	7 mm

Direction of the Joint #5 motion

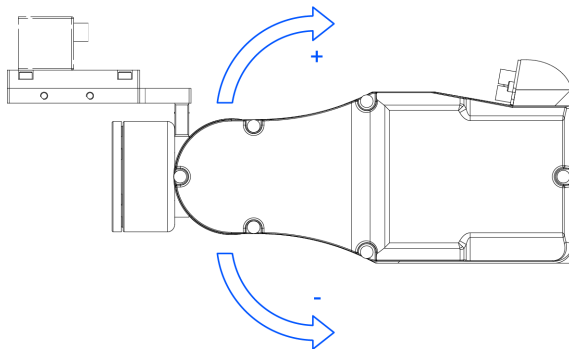

2.6.3 PS Compatible Plate (Tool Adapter)

Using the PS compatible plate, you can mount the hand used in the PS series to the C4 series. Also you can mount the hand with flange which is conformed to ISO9409-1.

Parts Included		Qty.
a	Hexagon socket head cap bolt M3×8	8
b	PS compatible plate 2	1

Parts Included		Qty.
c	Hexagon socket head cap bolt M4×6	4
d	PS compatible plate 1	1
e	Dowel pin (M3 hole on one side)	2

Dimensions of PS compatible plate

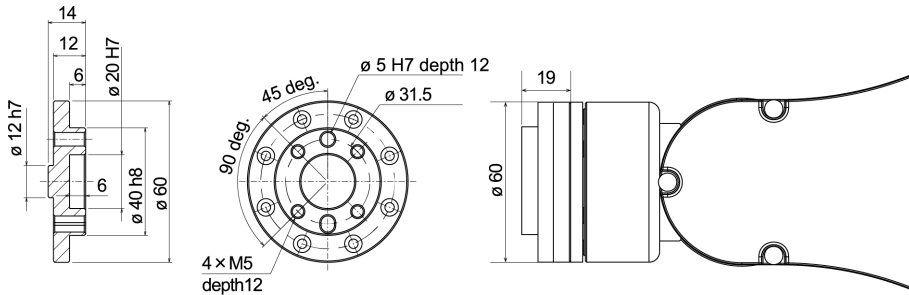

depth = depth of threaded hole
 90° pitch

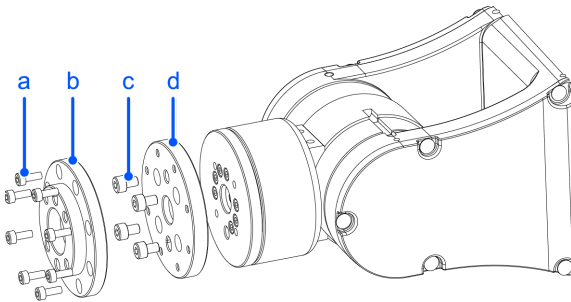

* Each dimension and tolerance complies with ISO9409-1-31.5-4-M5.

Installation

KEY POINTS

For details of tightening the hexagon socket head cap bolt, refer to the following section.

Tightening the Hexagon Socket Head Cap Bolts

1. Align the hole ($\varnothing 12$ H7) on the arm end flange to the projection ($\varnothing 12$ h7) on the PS compatible plate 1.
2. Insert the dowel pin from the PS compatible plate 1 side and position the arm and PS compatible plate 1.

- Secure the PS compatible plate 1 with 4 hexagon socket head cap bolts.
4×M4×6

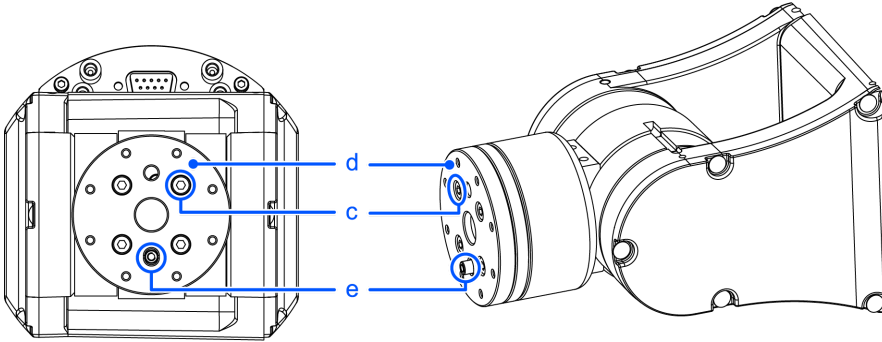

KEY POINTS

If you move the Manipulator with the dowel pin inserted, the dowel pin will fall out. After fixing the PS compatible plate 1, remove the dowel pin.

- Align the hole ($\varnothing 12H7$) on the PS compatible plate 1 to the projection ($\varnothing 12h7$) on the PS compatible plate 2.
- Insert the dowel pin from the PS compatible plate 2 side and position the PS compatible plate 1 and 2.
- Secure the PS compatible plate 2 with 8 hexagon socket head cap bolts.
8×M3×8

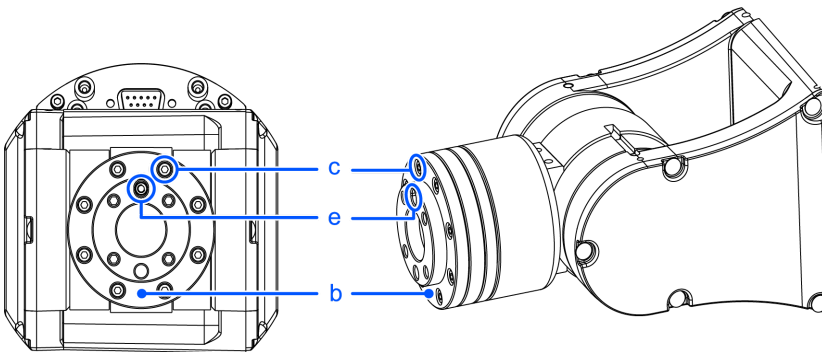

KEY POINTS

If you move the Manipulator with the dowel pin inserted, the dowel pin will fall out. After fixing the PS compatible plate 2, remove the dowel pin.

2.6.4 Base Side Angled Fittings

By using the base side angled fittings to the C4 series Manipulator base, you can mount the Manipulator in skewed position. The motion range expands with this mounting type compared to the normal ceiling mounting.

Mounting image using the base side angled fittings

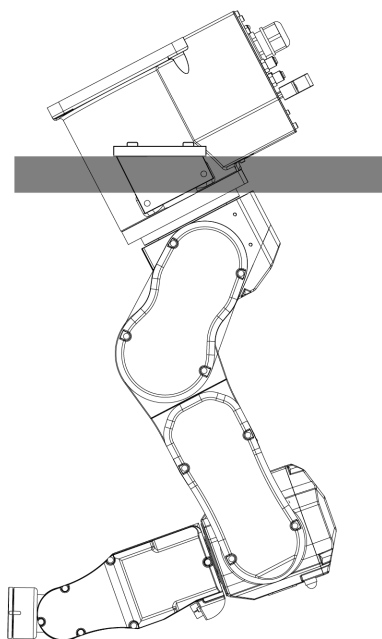

For the information on how to mount and precautions, refer to the following section.

Environment and Installation

Parts Included		Qty.
a	Hexagon socket head cap bolt M8×30	4
b	Base side plate (for Skewed mounting type)	2
c	Pin	6
d	Base side angled plate (Left side)	1
e	Base side angled plate (Right side)	1
f	Hexagon socket head cap bolt M8×25	4

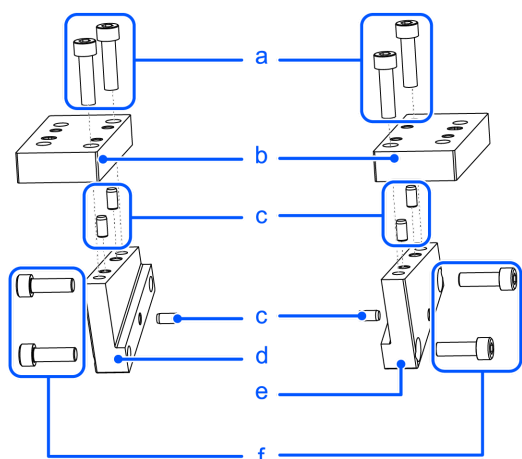

To mount the base side angled fittings

KEY POINTS

For details of tightening the hexagon socket head cap bolt, refer to the following section.

Tightening the Hexagon Socket Head Cap Bolts

1. Drive pins to the base side plate (for Skewed mounting type).

Protruding part of pins is approx. 2 to 5 mm.

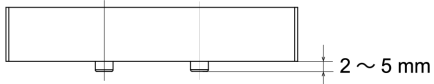

2. Drive pins to the base side angled plate (left and right sides).

Protruding part of pins is approx. 2 to 5 mm.

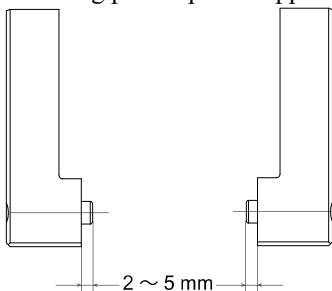

3. Create a base side angled fittings. Fit the pins of the plate for Skewed mounting type in the step (1) with the holes on the plate in the step (2) and secure with the screws.

Hexagon socket head cap bolt M8×30

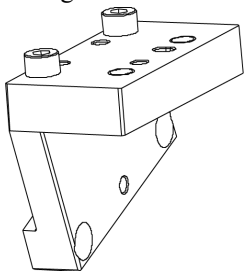

4. Mount the base side angled fittings to the both sides of Manipulator base. Fit the pins drove in the step (2) with the holes on the base. Secure the fittings by pressing it to the indicated direction in the figure below.

Left and Right side Hexagon socket head cap bolt 2×M8×25

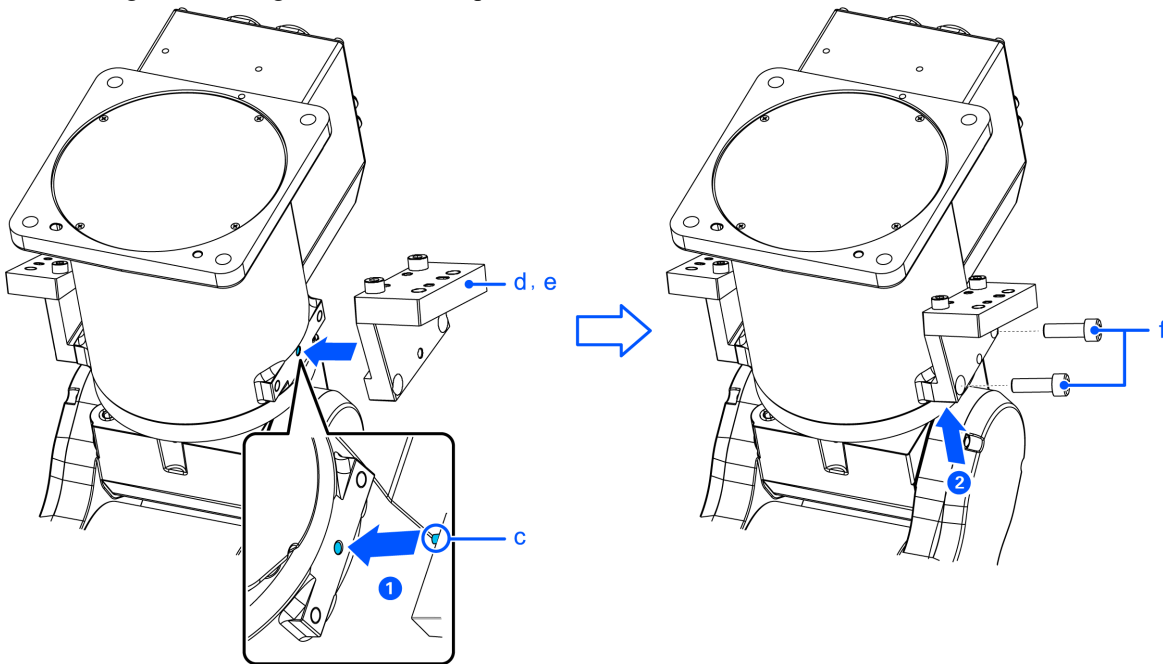

KEY POINTS

The shape of the base side angled fittings is asymmetry. Be sure to mount the fittings in correct direction. Otherwise, the motion range of Arm #2 is limited in the backside.

KEY POINTS

The recommended base plate thickness is between 30 mm and 40 mm. If the thickness is more than 40 mm, the Manipulator may contact the base plate when the Arm #1 rotates depending on the center cut dimension in the base plate.

The base plate securing the Manipulator should be prepared by users. The torque value and reaction force generated in the Manipulator motions are described in the following section.

From Unpacking to Installation

2.6.5 Base Side Fittings

Using the base side fittings to the C4 Manipulator base, you can mount the Manipulator in the place where limits the mounting height or use the open room for the base.

Mounting image using the base side fittings

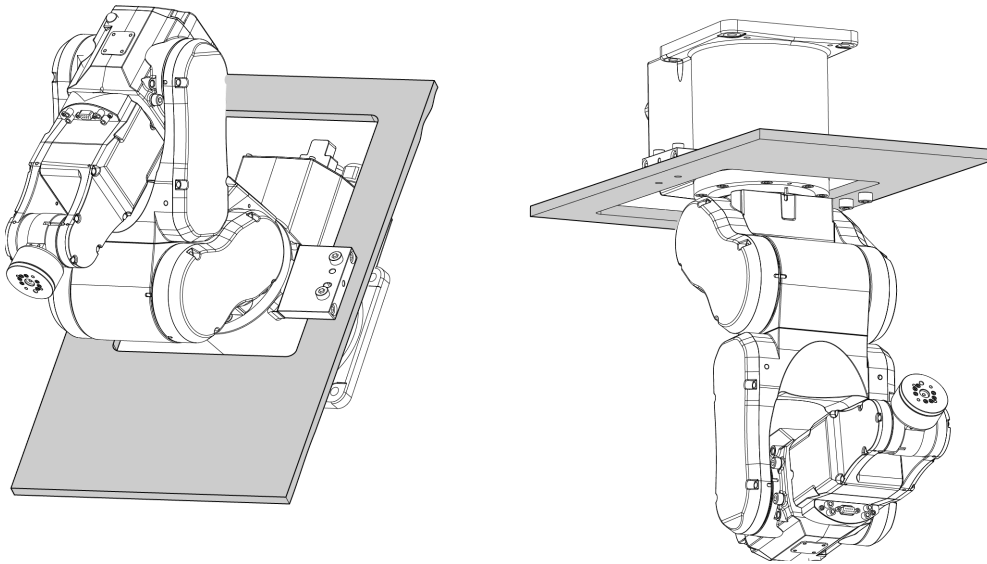

For the information on how to mount and precautions, refer to the following section.

Environment and Installation

Parts Included		Qty.
a	Base side plate	2
b	Pin	2
c	Hexagon socket head cap bolt M8×60	4

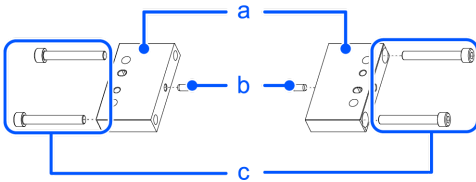

To mount the base side plate

KEY POINTS

For details of tightening the hexagon socket head cap bolt, refer to the following section.

Tightening the Hexagon Socket Head Cap Bolts

1. Drive the pins to the base side plate.
Protruding part of pins is approx. 2 to 5 mm.

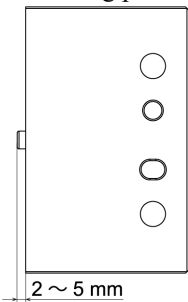

2. Mount the base side plate with the pins driven to the both sides of the base.

Fit the pins with the holes and secure the base side plate by pressing it from above to the base fixing part. (With the steps above, the both surfaces of base side fittings can be stable.)

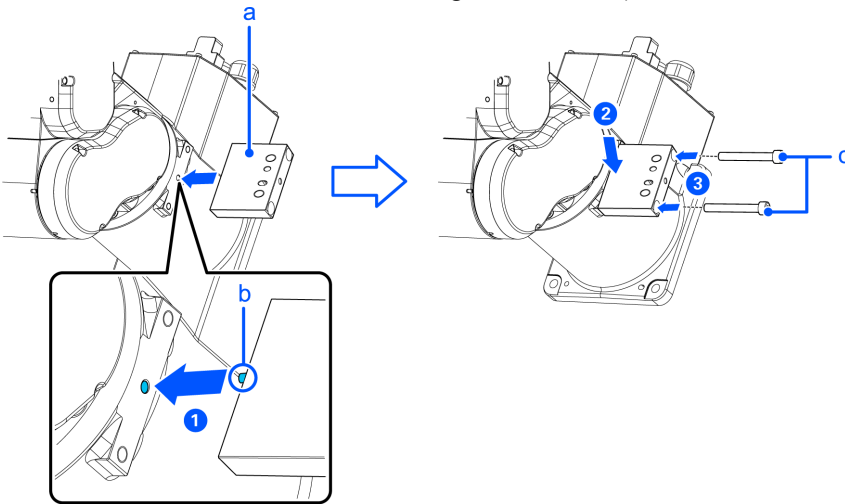

Dimension of the Manipulator with the base side fittings

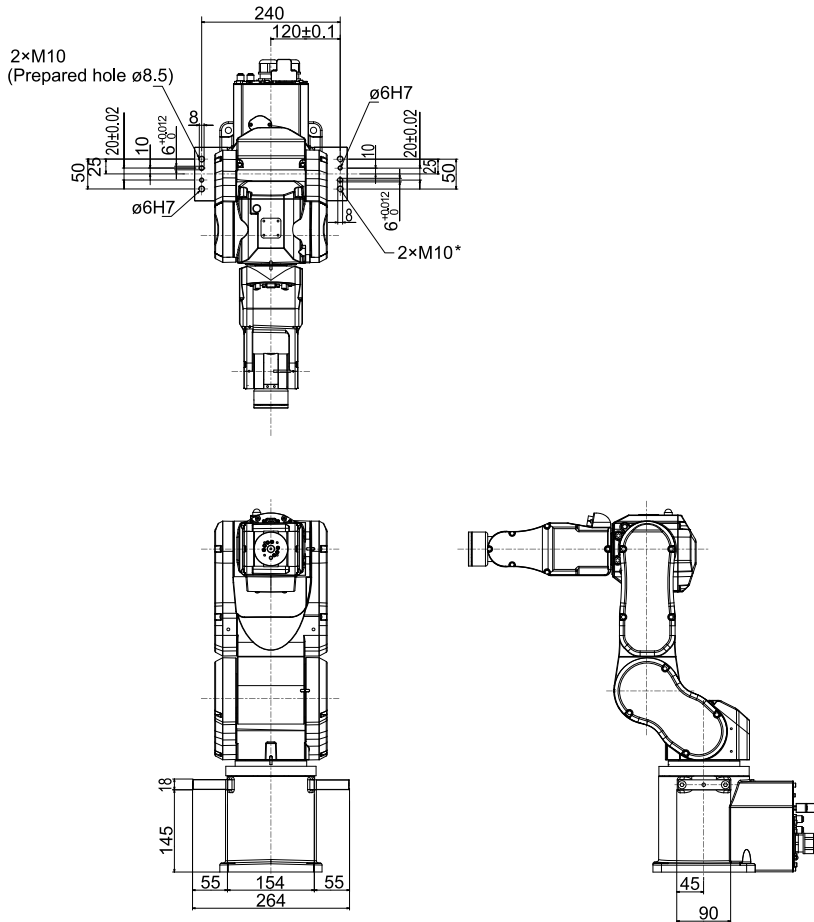

* 2xM10 (prepared threaded hole ø8.5)

Mounting example

Screws

	Size	Recommended Length
A	M8	30 mm or more

	Size	Recommended Length
B	M10	15 mm + base plate or more

KEY POINTS

The base side plate has a M10 threaded hole. You can secure the plate with a M10 screw or a M8 screw by using the prepared screw hole of $\varnothing 8.5$ to make a M8 screw hole on the mounting surface.

KEY POINTS

When you install the Manipulator for practical use, you need to insert the screws in the right/left side from the same direction (above or below).

Table top mounting

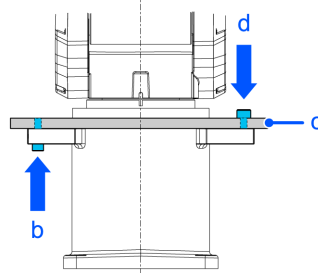
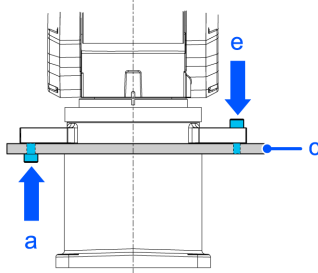
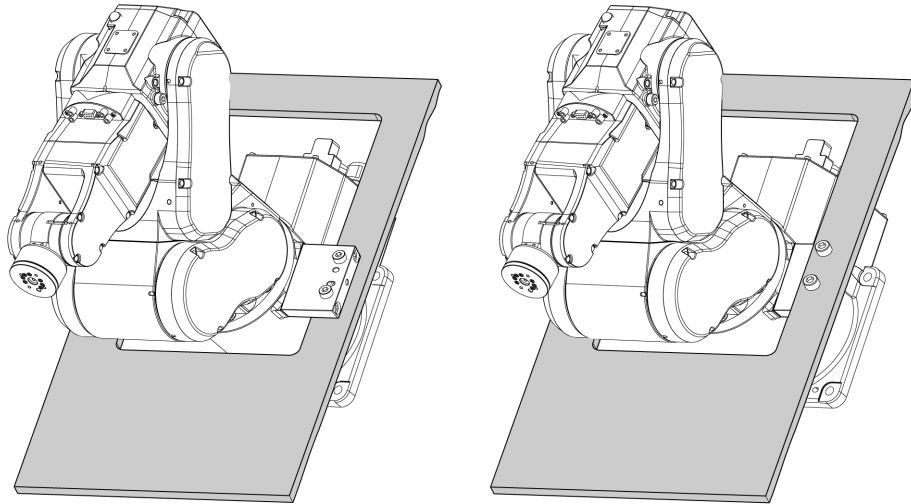

Symbol	Description
a	B: Secures from below
b	A: Secures from below
c	Base plate (Table top)
d	B: Secures from above
e	A: Secures from above

Ceiling mounting

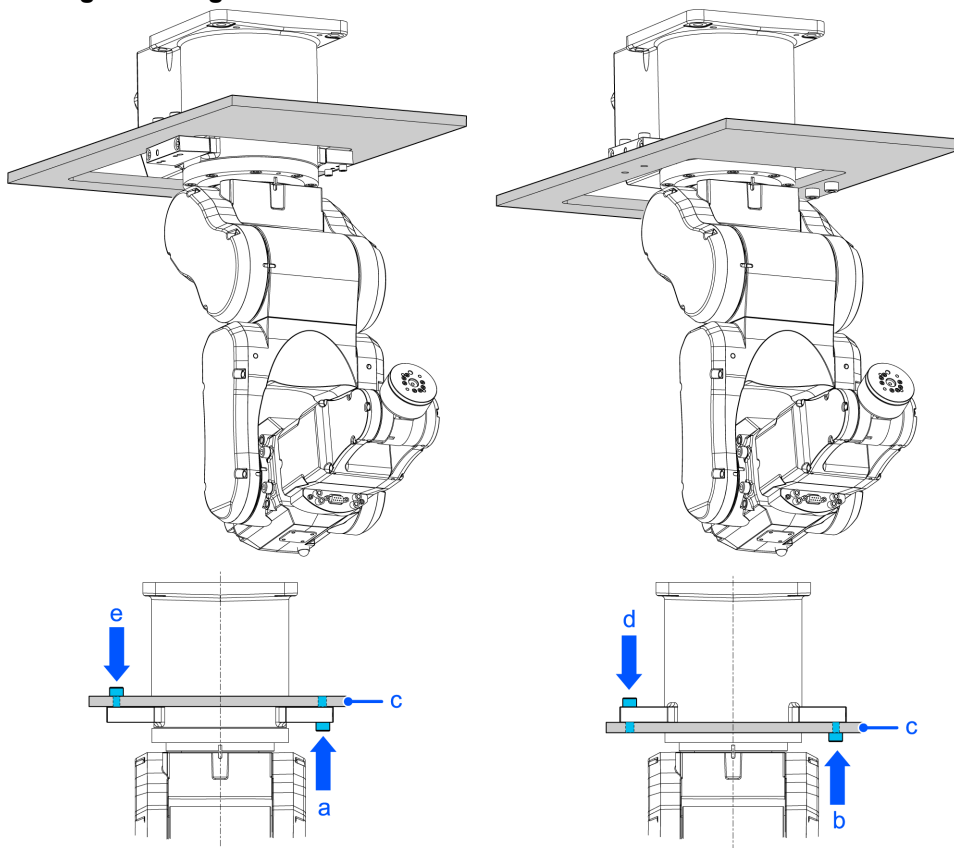

Symbol	Description
a	A: Secures from below
b	B: Secures from below
c	Base plate (Ceiling)
d	A: Secures from above
e	B: Secures from above

2.6.6 PS Compatible Plate (Base Adapter)

PS compatible plate is used to use Manipulator fixing taps for PS series to the C4 series Manipulator.

Parts Included		Qty.
a	PS compatible plate	1
b	Dowel pin (M4 hole on one side)	3
c	Dowel pin (M6 hole on one side)	2
d	Hexagon socket head cap bolt M10×25	8
e	Plain washer	4
f	Spring washer	8

Dimensions of PS compatible plate

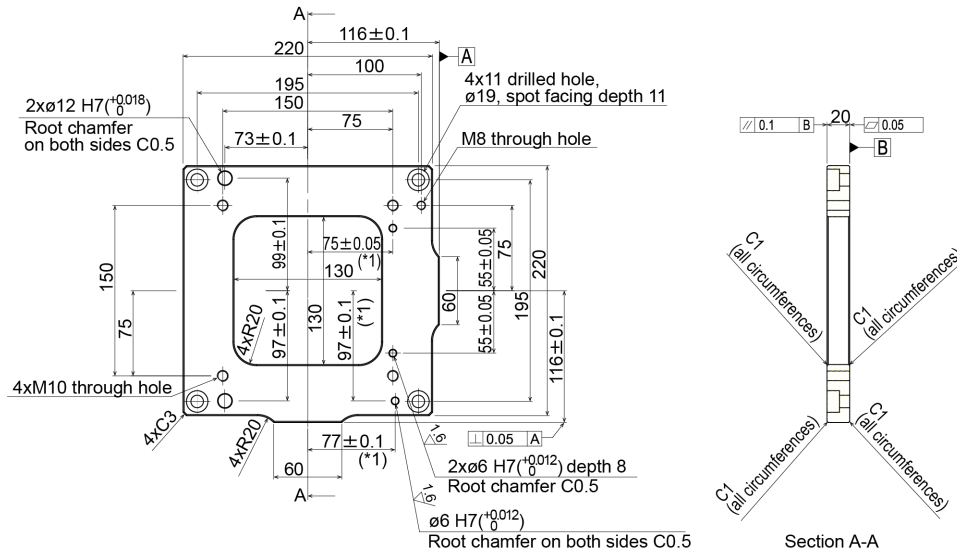

*1 Tolerance applicable to ø6H7

Installation

KEY POINTS

For details of tightening the hexagon socket head cap bolt, refer to the following section.

[Tightening the Hexagon Socket Head Cap Bolts](#)

1. Fix the base table and the PS compatible plate with hexagon socket head cap bolts (4×M10×25) and spring washers. Use dowel pins as needed to adjust positions of the base table and the PS compatible plate.
2. Fix the C4 series Manipulator and the PS compatible plate. Hexagon socket head cap bolts (4×M10×25) + spring washers + plain washers Use dowel pins as needed to adjust positions of the Manipulator and the PS compatible plate.

2.6.7 Variable Mechanical Stop

This option is used to mechanically limit the motion range of the Manipulator.

For installation and angle restriction measures, refer to the following section.

[Setting the Work Envelope by Mechanical Stops](#)

Variable Mechanical Stop (J1)

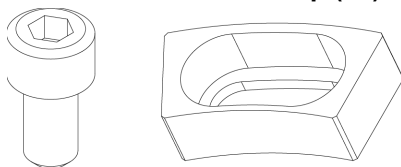

Parts Included		Qty.
a	Variable Mechanical Stop (J1)	1
b	Hexagon socket head cap bolt M8×5	1

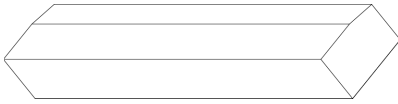
Variable Mechanical Stop (J2)

Parts Included		Qty.
a	Variable Mechanical Stop (J2)	1

3. C8 Manipulator

This chapter contains information for setup and operation of the Manipulators.

Please read this chapter thoroughly before setting up and operating the Manipulators.

3.1 Safety

The Manipulator and its related equipment should be unpacked and transported by people who have received installation training provided by Epson and the suppliers. Also, the laws and regulations of the installation country must be followed.

Before use, please read this manual and other related manuals to ensure correct use. After reading this manual, store it in an easily accessible location for future reference.

This product is intended for transporting and assembling parts in a safely isolated area.

3.1.1 Conventions Used in This Manual

The following symbols are used in this manual to indicate important safety information. Be sure to read the descriptions shown with each symbol.

WARNING

This symbol indicates an imminently hazardous situation which, if operation is not performed properly, will result in death or serious injury.

WARNING

This symbol indicates a potentially hazardous situation which, if operation is not performed properly, could result in an injury due to electric shock.

CAUTION

This symbol indicates a potentially hazardous situation which, if operation is not performed properly, may result in a minor or moderate injury or in property damage only.

3.1.2 Design and Installation Safety

The robot system should be designed and installed by people who have received installation training provided by Epson and the suppliers.

Design personnel should refer to the following manuals:

- "Safety Manual"
- "Controller Manual"
- "Manipulator Manual"

Refer to the following section for the installation safety information.

[Environment and Installation](#)

Be sure to read this section and follow the safety information before installation to ensure that the installation work is performed safely.

3.1.3 Operation Safety

The following items are safety precautions for operating personnel:

WARNING

- Be sure to read the Safety Manual before use. Operating the robot system without understanding the safety information can be extremely dangerous and may result in serious injury or severe equipment damage.
- Before operating the robot system, make sure that no one is inside the safety barriers. The robot system can be operated in the teaching operation mode even when someone is inside the safety barriers. Even though the motion of the Manipulator is always restricted (low speed and low power) to ensure operator safety, an unexpected movement by the Manipulator can be extremely dangerous and may cause serious safety problems.
- If the Manipulator moves abnormally during operation of the robot system, immediately press the emergency stop switch.

WARNING

- To perform the power supply lockout, remove the power plug. Be sure to connect the AC power cable to a power outlet. Do not connect it directly to a factory power source.
- Before performing any replacement work, inform others in the area that you are working, and then turn off the Controller and related equipment, and unplug the power cable from the power source. Performing any work procedure with the power turned on is extremely dangerous and may result in electric shock and/or malfunction of the robot system.
- Do not connect or disconnect the connector of the M/C cable while the Controller is turned on. There is a risk the Manipulator may malfunction, which is extremely hazardous. Also, performing any work procedure with the power turned on may result in electric shock and/or malfunction of the robot system.

CAUTION

- Whenever possible, only one person should operate the robot system. If it is necessary to operate with more than one person, ensure that all personnel communicate with each other and take all necessary safety precautions.
- If the Manipulator is operated repeatedly with each joint having an operating angle of 5° or less, the bearings used in the joints are likely to cause oil film shortage. Repeated operation may cause premature damage. To prevent premature damage, operate the Manipulator to move each joint to an angle of 30° or more about once per hour.
- When the robot is operating at low speed (Speed: 5 to 20%), vibration (resonance) may occur continuously during operation depending on the combination of the arm orientation and hand load. Vibration occurs due to the natural vibration frequency of the arm and can be reduced by taking the following measures:
 - Changing the robot speed
 - Changing the teach points
 - Changing the hand load

3.1.4 Emergency Stop

Each robot system needs equipment that will allow the operator to immediately stop the system's operation. Install an emergency stop device by using emergency stop input from the Controller or other equipment.

Before using the emergency stop switch, be aware of the following points.

- The emergency stop switch should be used to stop the Manipulator only in case of emergencies.
- Besides pressing the emergency stop switch when an emergency occurs, to stop the Manipulator during program operation, use the Pause or STOP (program stop) statements assigned to a standard I/O.
The Pause and STOP statements do not turn off motor energization, and so the brake is not locked.

To place the robot system in emergency stop mode in a non-emergency (normal) situation, press the emergency stop switch while the Manipulator is not operating.

Do not press the emergency stop switch unnecessarily while the Manipulator is operating normally.

It could shorten the lifespan of the following components.

- Brakes
The brakes will be locked, which will shorten the lifespan of the brakes due to worn brake friction plates.
 - Normal brake lifespan:
About 2 years (when the brakes are used 100 times/day)
or about 20,000 times
- Reduction gears
An emergency stop applies an impact to the reduction gear, which can shorten its life.

If the Manipulator is stopped by turning off the Controller while it is operating, the following problems may occur.

- Reduced life and damage to reduction gear
- Position shift at the joints

If a power outage or other unavoidable Controller power-off occurs during Manipulator operation, check the following points after power is restored.

- Damage in reduction gear
- Shifting of the joints from their proper positions

If there was any shifting, maintenance is required. For more information, please contact the supplier.

Stopping distance of emergency stop

The Manipulator during operation cannot stop immediately after the emergency stop switch is pressed. Also, the stopping time and movement distance vary depending on the following factors.

- Hand weight, WEIGHT setting, ACCEL setting, workpiece weight, SPEED setting, movement posture, etc.

For the stopping time and movement distance of the Manipulator, refer to the following section.

[Appendix B: Stopping Time and Stopping Distance at Emergency Stop](#)

3.1.5 Safeguard (SG)

To maintain a safe working zone, safety barriers must be set up around the Manipulator, and safeguards must be installed at the entrance and exit of the safety barriers.

The term "safeguard" as used in this manual refers to a safety device with an interlock that allows entry into the safety barriers. Specifically, this includes safety door switches, safety barriers, light curtains, safety gates, safety floor mats, and so on. The safeguard is an input that informs the Robot Controller that an operator may be inside the safeguard area. You must assign at least one Safeguard (SG) in Safety Function Manager.

When the safeguard is opened, Protective Stop operates to change to the safeguard open state (display: SO).

- **Safeguard open**
Operations are prohibited. Further robot operation is not possible until either the safeguard is closed, the latched state is released, and a command is executed, or the TEACH or TEST operation mode is turned on and the enable circuit is activated.
- **Safeguard closed**
The robot can operate automatically in an unrestricted (high power) state.

WARNING

- If a third party accidentally releases the safeguard while an operator is working inside the safety barriers, this may result in a hazardous situation. To protect the operator working inside the safety barriers, implement measures to lock out or tag out the latch release switch.
- To protect operators working near the robot, be sure to connect a safeguard switch and make sure that it works properly.

Installing safety barriers

When installing safety barriers within the maximum range of the Manipulator, combine safety functions such as SLP. Carefully take into account the size of the hand and the workpieces to be held so that no interference occurs between the operating parts and the safety barriers.

Installing safeguards

Design the safeguards so that they satisfy the following requirements:

- When using a key switch type safety device, use a switch that forcibly opens the interlock contacts. Do not use switches that open their contacts using the spring force of the interlock.
- When using an interlock mechanism, do not disable the interlock mechanism.

Considering the stopping distance

During operation, the Manipulator cannot stop immediately even if the safeguard is opened. Also, the stopping time and movement distance vary depending on the following factors.

- Hand weight, WEIGHT setting, ACCEL setting, workpiece weight, SPEED setting, movement posture, etc.

For the stopping time and movement distance of the Manipulator, refer to the following section.

[Appendix C: Stopping Time and Stopping Distance When Safeguard is Open](#)

Precautions for safeguard operation

Do not open the safeguard unnecessarily while the motor is energized. Frequent safeguard inputs will reduce the life of the relay.

- Normal relay lifespan: About 20,000 times

3.1.6 How to Move Arms with the Electromagnetic Brake

There are two methods to release the electromagnetic brake. Follow either method to release the electromagnetic brake and move the arms manually.

- **When using a brake release unit**
Follow the method when you just unpack the delivered boxes or when the Controller does not start up yet.
- **When using software**
Follow the method when you can use the software.

While the electromagnetic brake is on (such as in emergency mode), you cannot move any arm by pushing manually.

Arm Motion

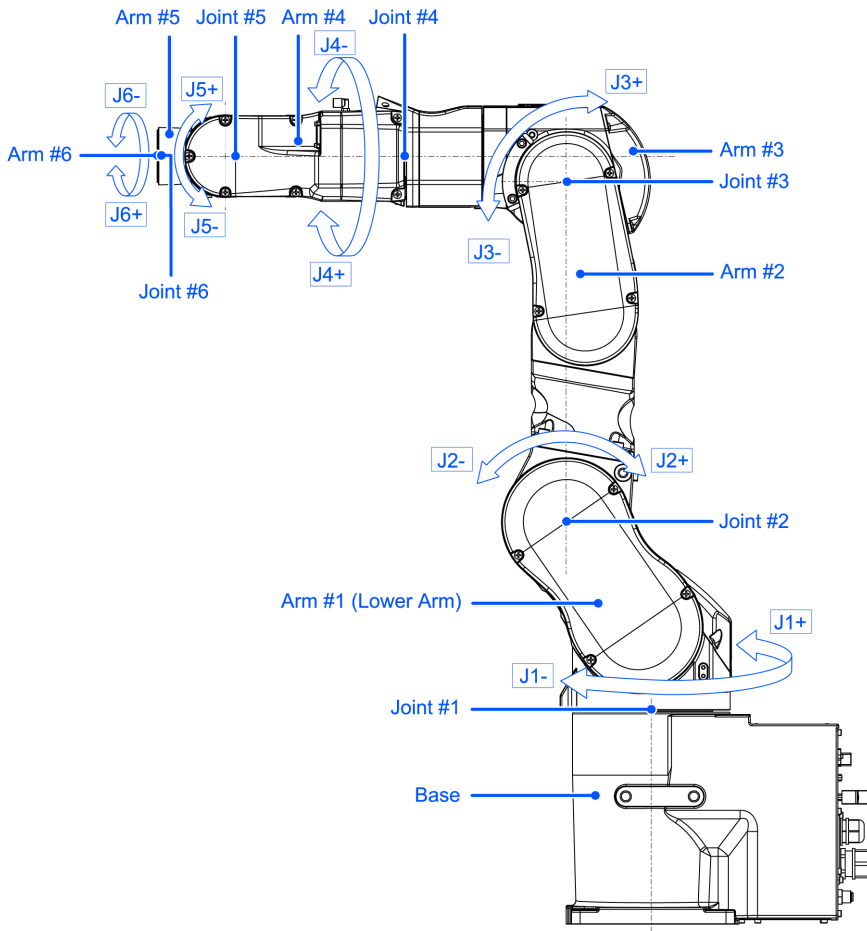

3.1.6.1 When using a brake release unit

This series has the Brake Release Unit as an option. For details, refer to the following section.

Options

3.1.6.2 When using software

⚠ CAUTION

- Normally, release the brakes of joints one at a time. If the brakes of two or more joints must be released simultaneously due to unavoidable reasons, use extreme care. Releasing the brakes of multiple joints simultaneously may cause the arm to fall in an unexpected direction, resulting in hands or fingers getting caught or damage or failure of the Manipulator.
- After releasing the brake, the arm may fall by its own weight or move to the unexpected direction. Make sure to prepare a countermeasure to prevent the arm from falling and check the operation environment is safe.
- Before releasing the brake, be sure to keep the emergency stop switch in an easily accessible location so that you can immediately press it if necessary. Otherwise, if the emergency stop switch is not easily accessible, you will be unable to immediately stop the arm falling due to an erroneous operation, which could lead to Manipulator damage or breakdown.



After releasing the Emergency Stop switch, execute the following command in [Command Window].

```
>Reset
>Brake Off, [The number (from 1 to 6) corresponding to the arm whose brake will be
turned off]
```

Execute the following command to turn on the brake again.

```
>Brake On, [The number (from 1 to 6) corresponding to the arm whose brake will be
turned on]
```

3.1.7 Precaution for Operation in Low Power Status

In the low power status, the Manipulator operates at low speed and low torque. However, comparatively high torque as shown in the table below may be generated to support the Manipulator’s own weight. Carefully operate the Manipulator since it may get your hands or fingers caught during operation. The Manipulator may also collide with peripheral equipment and cause equipment damage to or malfunction of the Manipulator.

Maximum Joint Torque in Low Power Status [Unit: N·m]

Joint		#1	#2	#3	#4	#5	#6
Joint Torque	C8-B901*** (C8L)	172.10	300.96	129.34	34.97	39.96	20.54
	C8-B901**W (C8L)	452.88					
	C8-B1401*** (C8XL)	449.79	731.34	373.31	52.45	59.94	30.81
	C8-B1401**W (C8XL)	719.66					

⚠ CAUTION

- Carefully operate the Manipulator in the low power status. A comparatively high joint torque may be generated. It may cause your hands and fingers caught and/or cause equipment damage to or malfunction of the Manipulator as it may collide with peripheral equipment.

3.1.8 Warning Labels

The Manipulator has the following warning labels. Specific hazards exist in the vicinity of areas with the warning labels. Be thoroughly careful in handling. To ensure that the Manipulator is operated and maintained safely, be sure to follow the safety information and warnings indicated on the warning labels. Also, do not tear, damage, or remove these warning labels.

3.1.8.1 Warning Labels



Touching any internal electrified parts while the power is turned on may cause electric shock.

B



HOT Be careful not to burn yourself.

C



When releasing the brakes, be careful of the arm falling due to its own weight.

This warning label is attached on the Manipulator and optional brake release unit as well.

When the brake release unit is used:

When using a brake release unit to release brakes, refer to the following section.

How to Move Arms with the Electromagnetic Brake

3.1.8.2 Information Labels

1

This indicates the product name, model name, serial number, information of supported laws and regulations, product specifications (Weight, MAX.REACH, MAX.PAYLOAD, AIR PRESSURE, Motor Power), Main document No., manufacturer, importer, date of manufacture, country of manufacture, and the like.

For details, see the label affixed to the product.

2



This indicates the position for mounting eyebolts. Refer to the following section for examples of using eyebolts.

Environment and Installation

Location of Labels

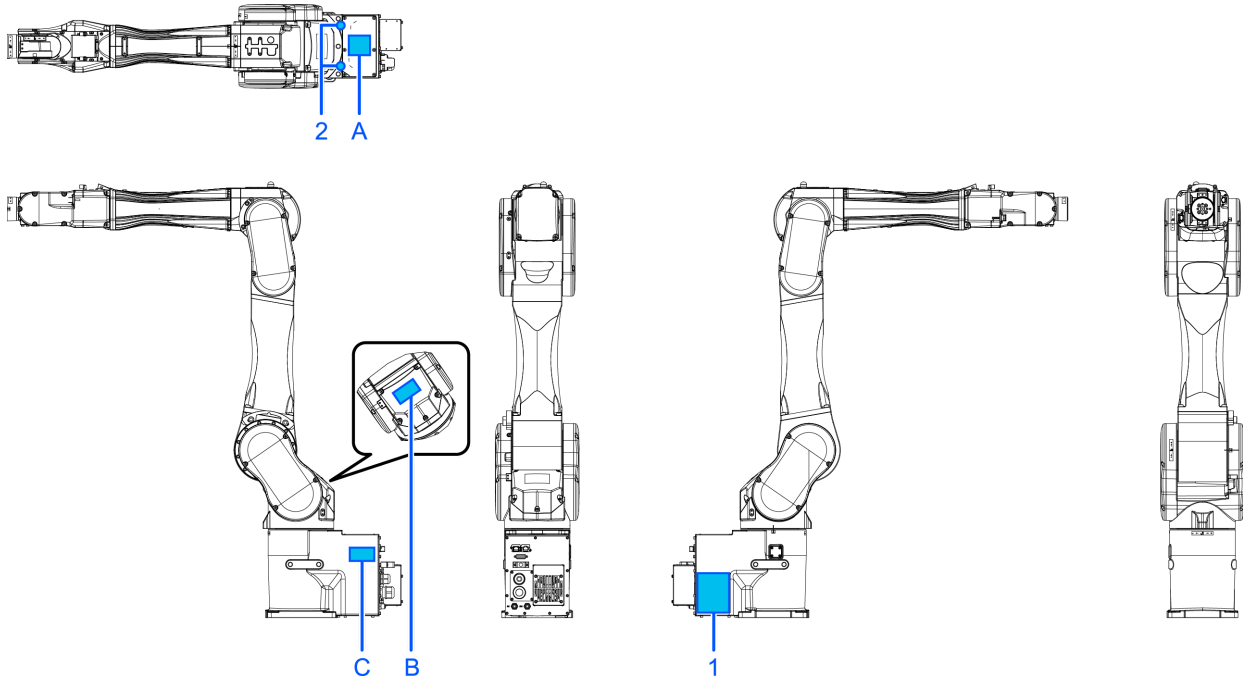

3.1.9 Responses for Emergencies or Malfunctions

3.1.9.1 When a Collision with the Manipulator Occurs

If the Manipulator has collided with a mechanical stop, peripheral device, or other object, discontinue use and contact the supplier.

3.1.9.2 Entanglement with the Manipulator

When the operator is caught between the Manipulator and a mechanical part such as a base table, press the emergency stop switch to release the brake on the subject arm, and then move the arm by hand.

How to release a brake

- When using a brake release unit, refer to the following section.
[Brake Release Unit](#)
- When using software, refer to the following section.
[When using software](#)

3.2 Specifications

3.2.1 Model Number

C8-B1401S

 [a] [b][c][d][e]

- a: Arm length
 - 9: 900 mm (Model name: C8L)
 - 14: 1400 mm (Model name: C8XL)
- b: Brake equipment
 - 1: Brakes on all joints

- c: Environment
 - S: Standard *1
 - C: Cleanroom & ESD (anti-static) *1
 - P: Protection *2
- d: M/C cable installation direction
 - □: Cable backward
 - B: Cable downward
- e: Mounting type
 - □: Table top mounting
 - R: Ceiling mounting
 - W: Wall mounting

*1 Equivalent to IP20

*2 IP67 (fan cover: equivalent to IP20)

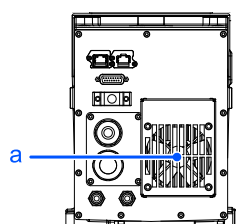

Symbol	Description
a	Fan cover

Example

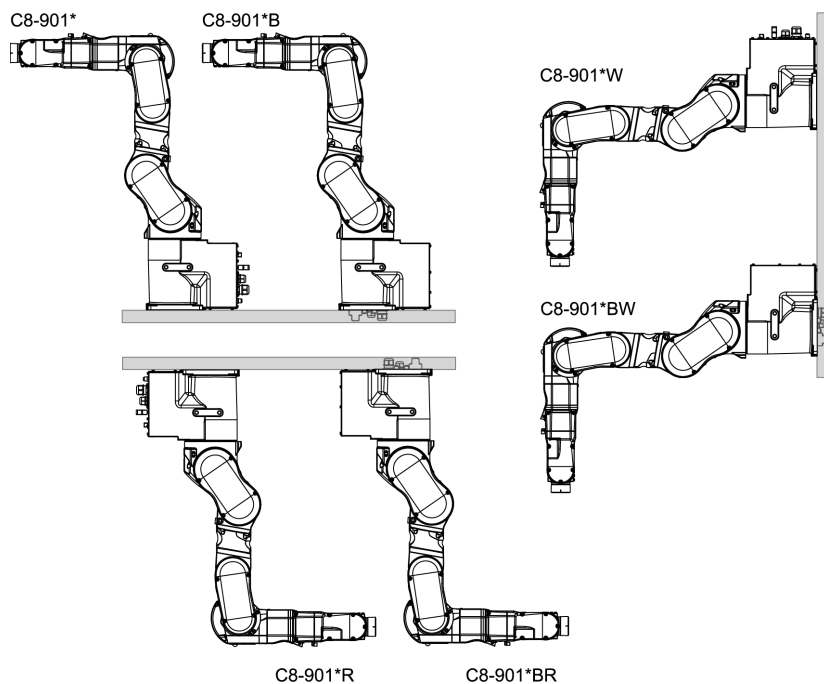

3.2.2 Part Names and Motion Range of Each Arm

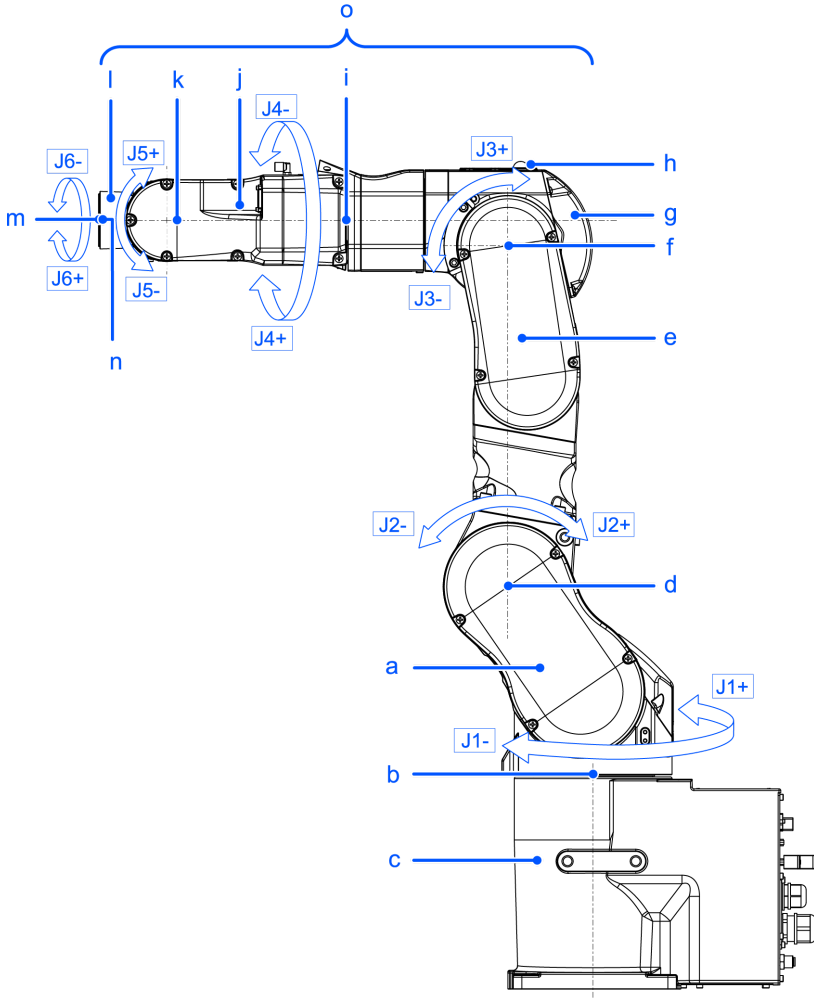

Symbol	Description
a	Arm #1 (Lower Arm)
b	Joint #1 (The whole Manipulator revolves.)
c	Base
d	Joint #2 (The lower arm swings.)
e	Arm #2
f	Joint #3 (The upper arm swings.)
g	Arm #3
h	LED Lamp (This lamp lights up while the motors are on.)
i	Joint #4 (The wrist revolves.)
j	Arm #4
k	Joint #5 (The wrist swings.)
l	Arm #5
m	Arm #6
n	Joint #6 (The hand rotates.)

Symbol	Description
o	Upper Arm (Arms #3 to #6)

KEY POINTS

When the LED lamp is lighting or the Controller power is on, the current is being applied to the Manipulator. (The LED lamp may not be seen depending on the Manipulator's posture. Be thoroughly careful. Performing any work procedure with the power turned on is extremely dangerous and may result in electric shock and/or malfunction of the robot system. Before starting any maintenance work, be sure to turn off the Controller.

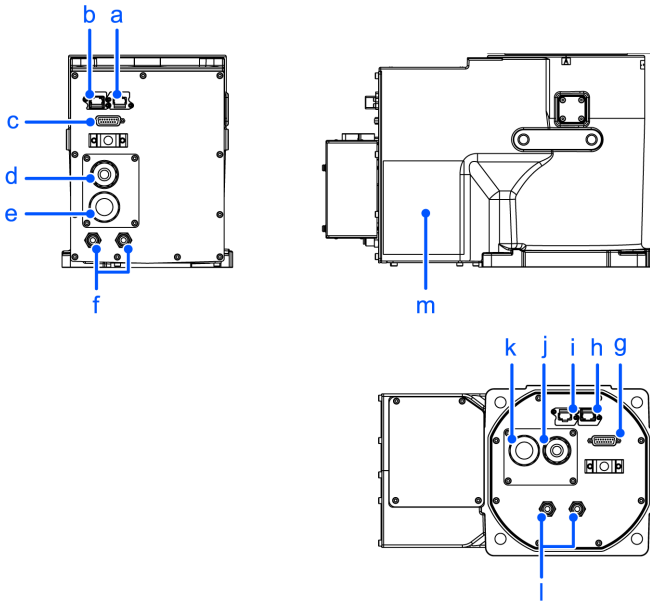

Cable backward model

Symbol	Description
a	Ethernet cable connector
b	Force Sensor cable connector
c	User cable connector (15-pin D-sub connector)
d	Signal cable
e	Power cable
f	Fitting for ø6 mm tube (Air1, Air2)

Cable downward model

Symbol	Description
g	User cable connector (15-pin D-sub connector)
h	Force Sensor cable connector
i	Ethernet cable connector
j	Signal cable
k	Power cable

Symbol	Description
l	Fitting for $\varnothing 6$ mm tube (Air1, Air2)

Cable backward model, Cable downward model

Symbol	Description
m	Face plate (serial number of Manipulator)

3.2.3 Outer Dimensions

3.2.3.1 C8-B901*** (C8L)

(Units: mm)

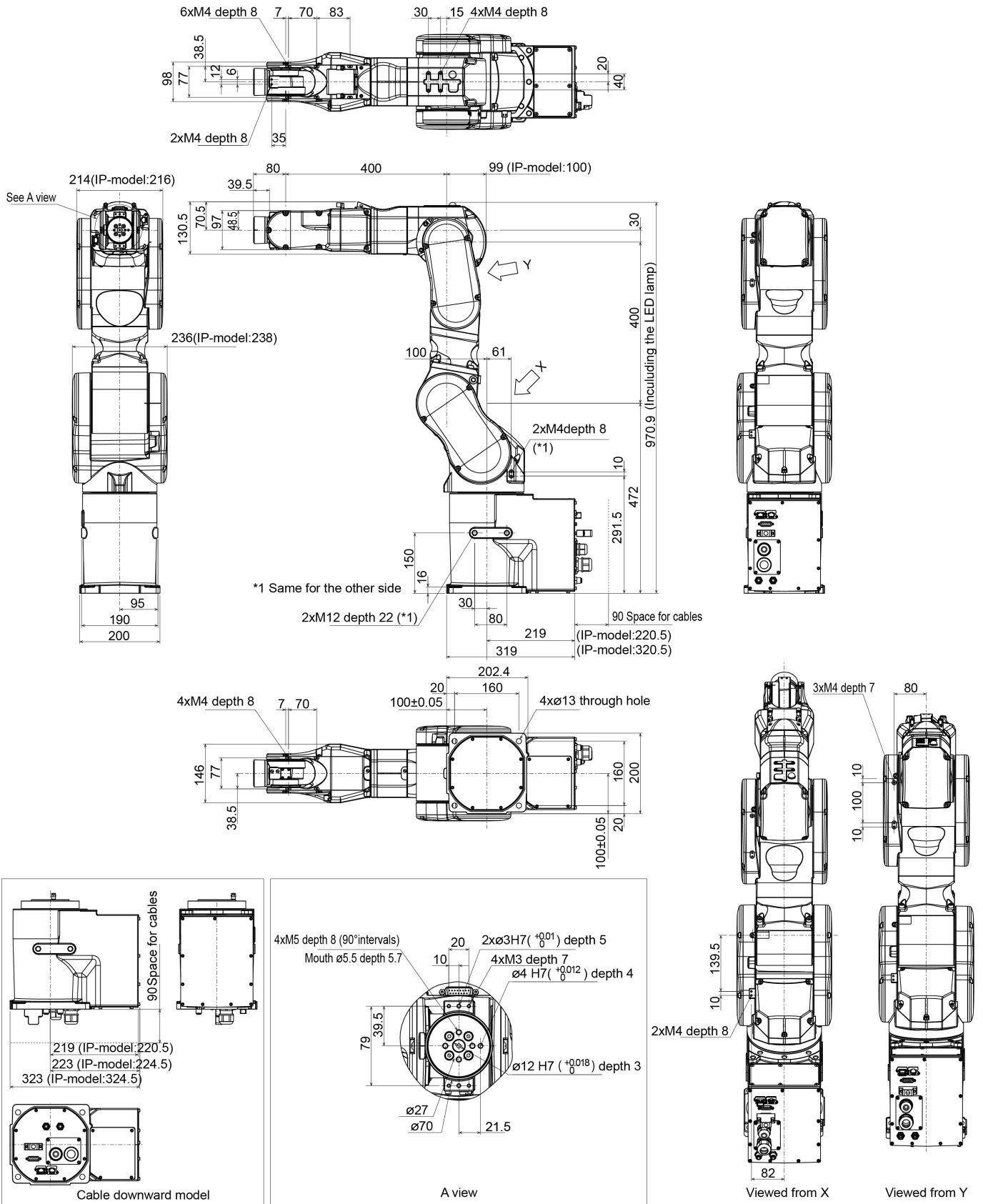

3.2.3.2 C8-B1401* (C8L)**

(Units: mm)

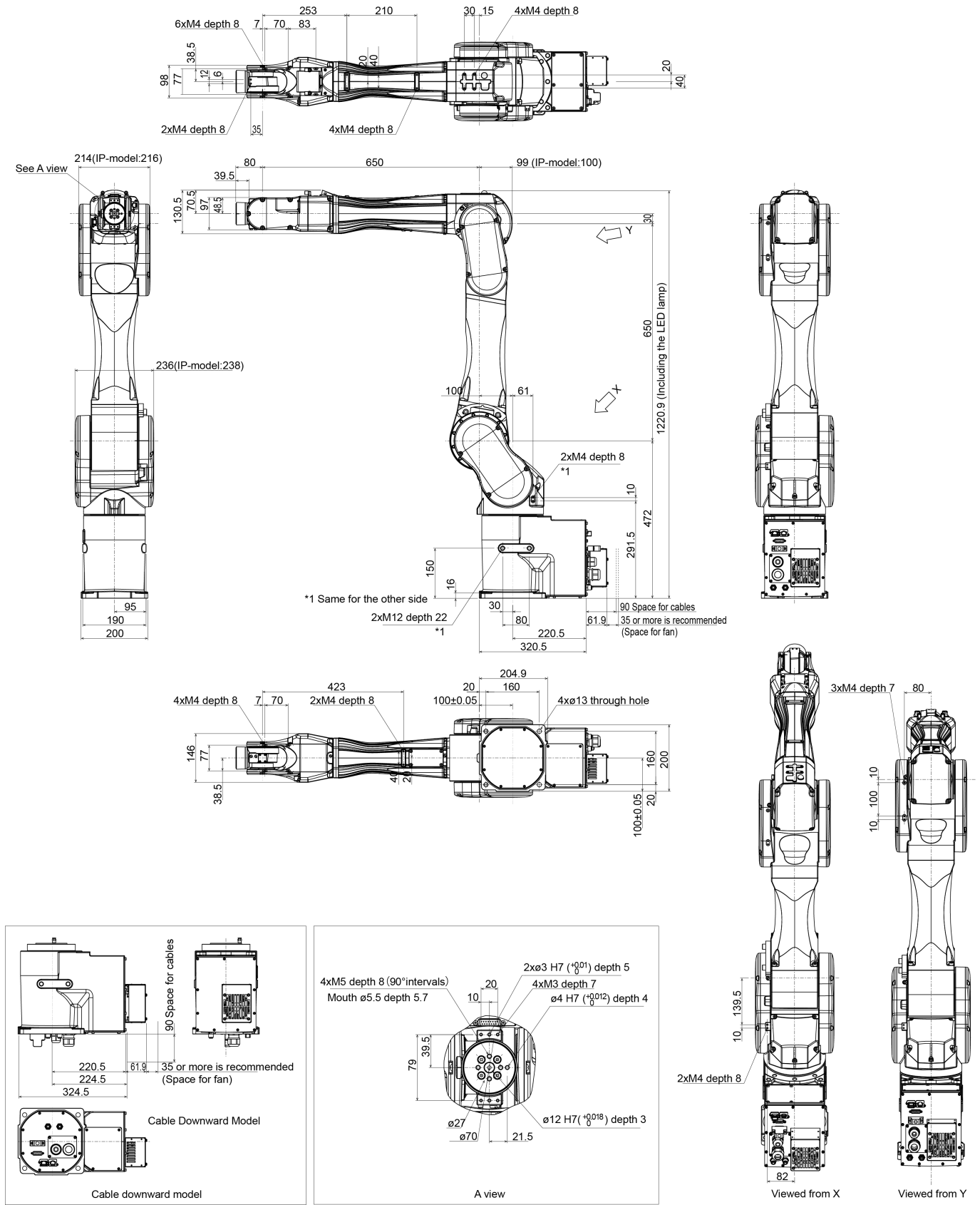

3.2.4 Standard Work Envelope

3.2.4.1 C8-B901*** (C8L)

(Units: mm)

Top view

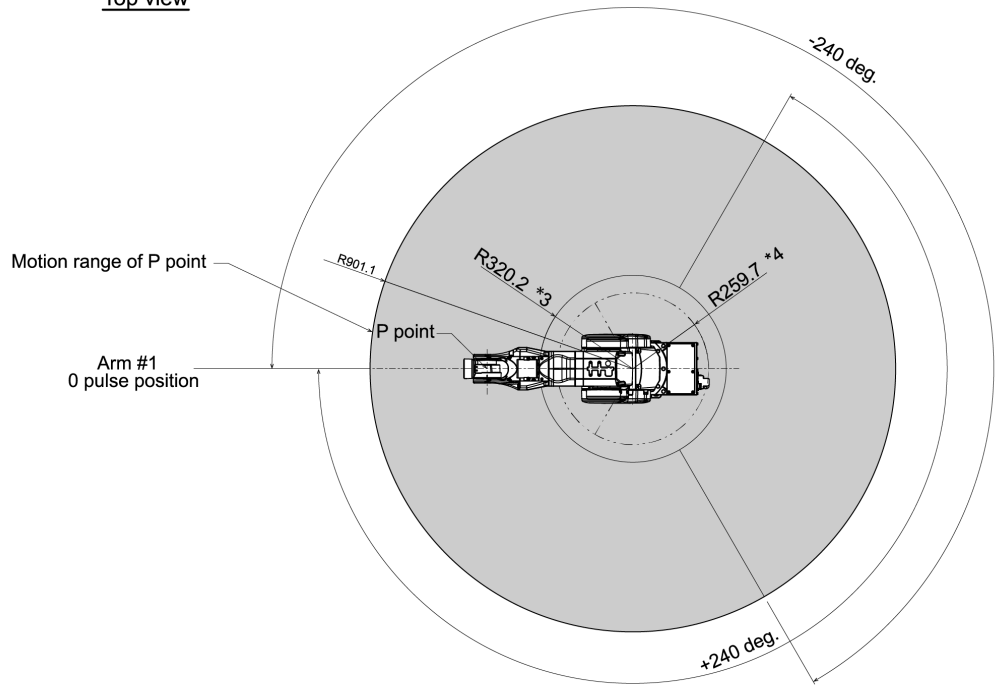

Front view

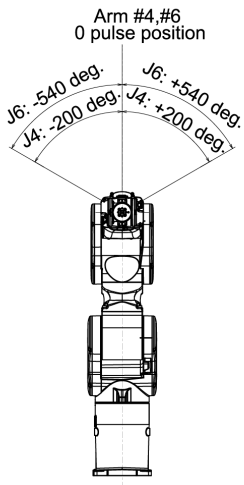

Lateral view

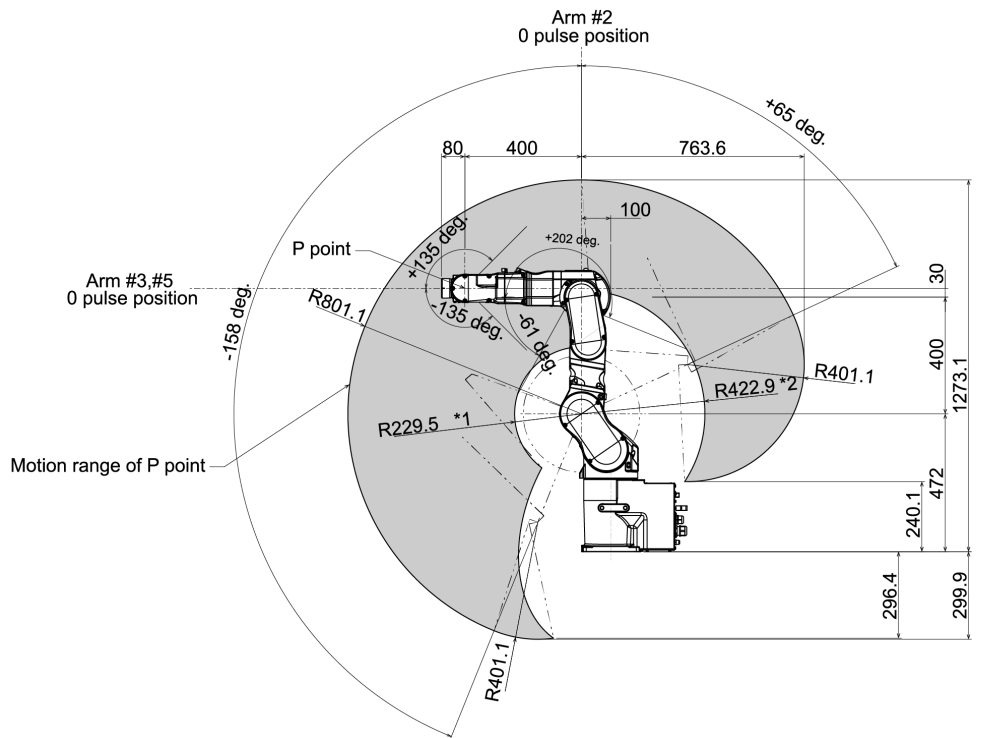

(deg. = °)

*P point: Intersection of the rotation centers for Joint #4, #5, and #6

*1: P point from lateral with Joint #3 declining -61° (Joint #2 center – P point center)

*2: P point from lateral with Joint #3 tilting up +202° (Joint #2 center – P point center)

*3: P point from top with Joint #3 declining -61° (Joint #1 center – P point center)

*4: P point from top with Joint #3 tilting up $+202^{\circ}$ (Joint #1 center – P point center)

CAUTION

- Pay attention to the arm pose of the basic arms (Arms #1, #2, and #3) when operating the Manipulator. Arm #5 moves keeping a constant angle regardless of the arm pose. Depending on the arm pose of the basic arms, the wrist may collide with the Manipulator. The collision may cause equipment damage to and/or malfunction of the Manipulator.

3.2.4.2 C8-B1401* (C8XL)**

(Units: mm)

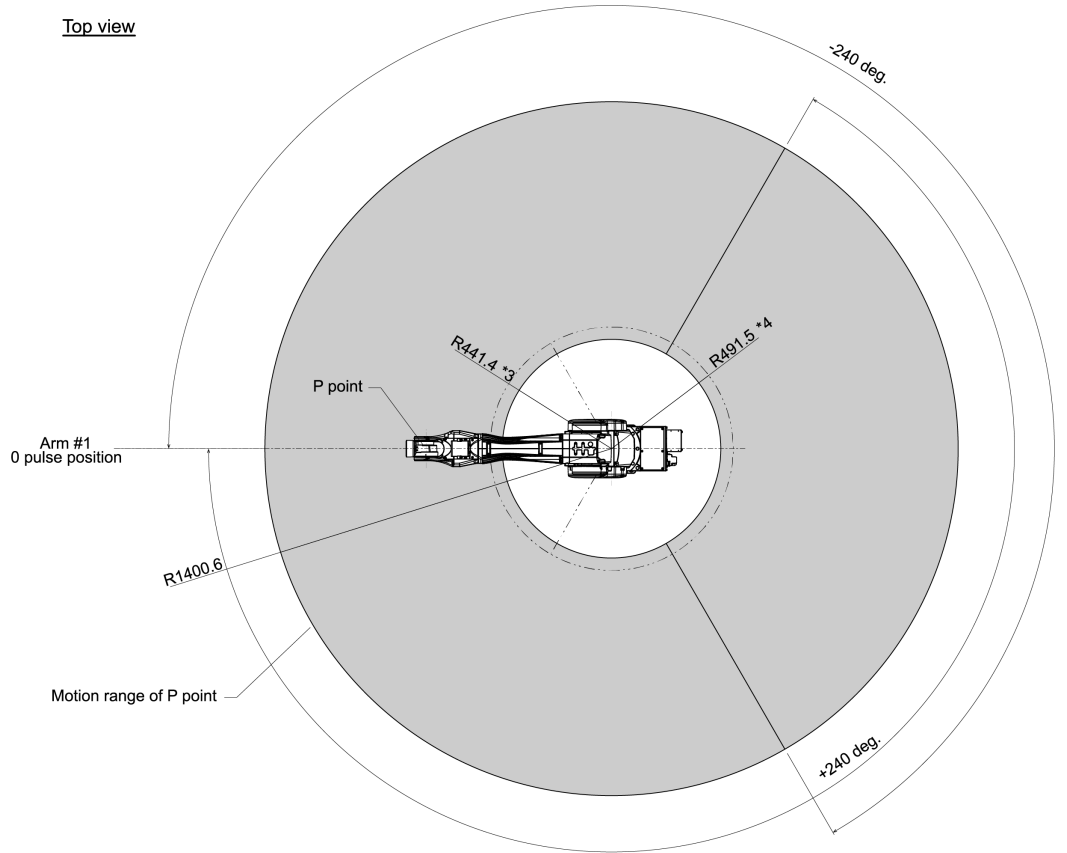

Front view

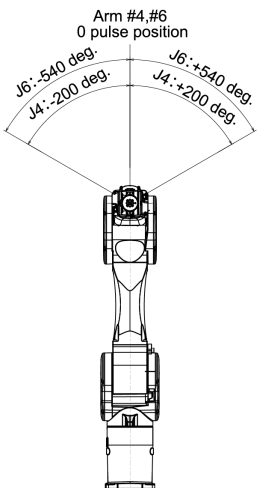

Lateral view

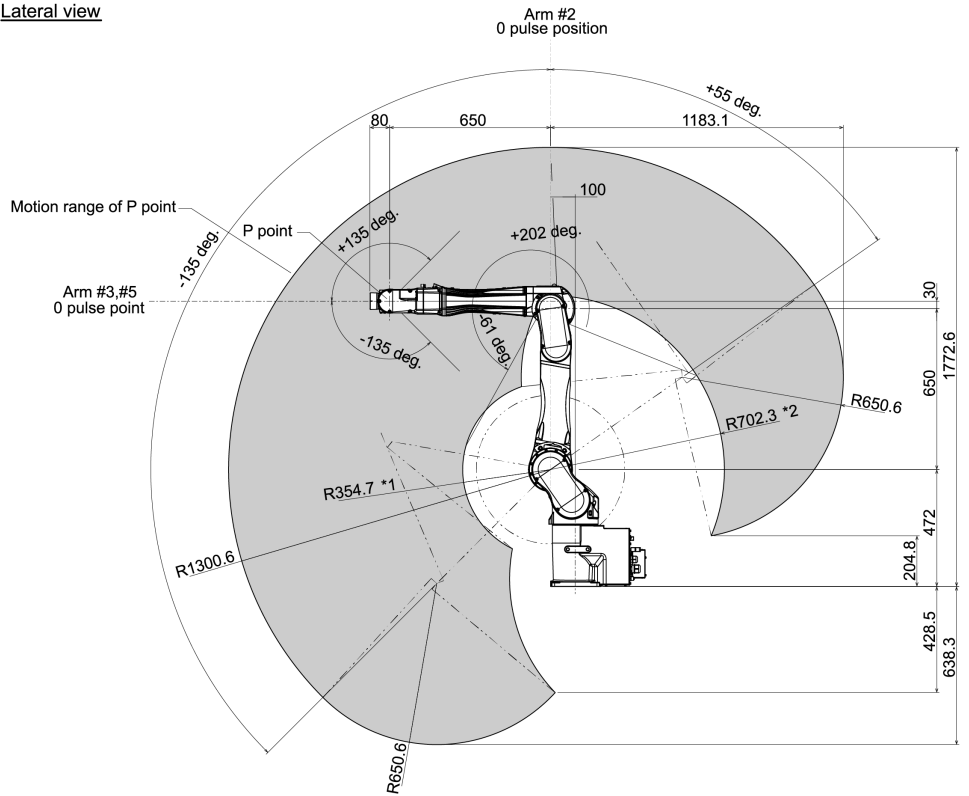

(deg. = °)

*P point: Intersection of the rotation centers for Joint #4, #5, and #6

*1: P point from lateral with Joint #3 declining -61° (Joint #2 center – P point center)

*2: P point from lateral with Joint #3 tilting up $+202^{\circ}$ (Joint #2 center – P point center)

*3: P point from top with Joint #3 declining -61° (Joint #1 center – P point center)

*4: P point from top with Joint #3 tilting up $+202^{\circ}$ (Joint #1 center – P point center)

CAUTION

- Pay attention to the arm pose of the basic arms (Arms #1, #2, and #3) when operating the Manipulator. Arm #5 moves keeping a constant angle regardless of the arm pose. Depending on the arm pose of the basic arms, the wrist may collide with the Manipulator. The collision may cause equipment damage to and/or malfunction of the Manipulator.

3.2.5 Specifications

3.2.5.1 Specifications Table

For the specifications tables of each model, refer to the following section.

[C8 Specifications](#)

3.2.5.2 Options

For details, refer to the following section.

[Options](#)

3.2.6 How to Set the Model

The Manipulator model for your system has been set before shipment from the factory.

CAUTION

- If changing the setting of the Manipulator model, be responsible and absolutely certain that the wrong Manipulator model is not set. Incorrect setting of the Manipulator model may result in abnormal or no operation by the Manipulator and could even cause safety problems.

If a custom specifications number (MT***) or (X***) is written on the face plate (serial number label), the Manipulator has custom specifications.

Models with custom specifications may require a different setting procedure. Check the custom specifications number, and contact the supplier for more information.

The Manipulator model is set from software. For details, refer to the following manual.
"Epson RC+ User's Guide - Robot Configuration"

3.3 Environment and Installation

The robot system should be designed and installed by people who have received installation training provided by Epson and the suppliers. Also, the laws and regulations of the installation country must be followed.

3.3.1 Environment

To ensure that the robot system operates and maintains maximum performance and to ensure its safe use, the robot system should be installed in an environment that meets the following requirements.

Item	Conditions
Ambient temperature *	Installation: 5 to 40°C Transport, storage: -20 to 60°C
Ambient relative humidity	Installation: 10 to 80% (no condensation) Transport, storage: 10 to 90% (no condensation)
Fast transient burst noise	1 kV or less (signal line)
Electrostatic noise	4 kV or less
Altitude	1000 m or less

* The ambient temperature requirement is for the Manipulator only. For details on the environment requirements for the connected Controller, refer to the Robot Controller manual.

 **KEY POINTS**

When used in a low-temperature environment near the minimum temperature specified in the product specifications, or when the unit is idle for a long period of time during holidays or at night, a collision detection error or similar error may occur immediately after the start of operation due to high resistance in the drive unit. In such cases, warm-up operation for about 10 minutes is recommended.

 **KEY POINTS**

If there are conductive objects such as fences or ladders within 2.5 m of the Manipulator, these objects must be grounded.

Also, depending on the environmental specifications of the Manipulator, the following requirements must be met.

Environmental Specifications	Conditions
S, C, P	<ul style="list-style-type: none"> - Install indoors. - Keep away from direct sunlight. - Keep away from shocks or vibrations. - Keep away from sources of electric noise. - Keep away from explosive areas. - Keep away from large quantities of radiation.
S, C	<ul style="list-style-type: none"> - Keep away from dust, oily smoke, salinity, metal powder, and other contaminants. - Keep away from flammable or corrosive liquids and gases. - Keep away from organic solvents, acids, alkalis, and chlorine cutting fluids. - Keep away from water.

The following items should also be taken into consideration for the installation environment of Manipulators with protected-models.

- These are compliant with the IP67 protection class (IEC 60529, JIS C0920). The Manipulators can be used in environments where the possibility of dust, water, and water-soluble cutting oil falling of the Manipulator exists.

- They can be installed in environments where dust, oil smoke, metal powder, and similar substances are airborne, but they are not suitable for use with nitrile rubber oil seals, O-rings, packings, liquid gaskets, or other substances that impair sealing performance.
- The Manipulator cannot be used in environments exposed to liquids or airborne droplets that are corrosive such as acids or alkalis.
- In environments that are exposed to airborne droplets containing salt, rust may also form on the Manipulator.
- Manipulator surfaces are generally oil-resistant, but if special oils are to be used, oil resistance should be checked before use. For more information, please contact the supplier.
- In environments with rapid changes in temperature and humidity, condensation may form inside the Manipulator.
- When handling food directly, it is necessary to make sure that the Manipulator is not likely to contaminate the food. For more information, please contact the supplier.
- The Controllers used with Manipulators with protected-models do not have protection against harsh environments. The Controller should be installed in a location that meets its operating environment requirements.

KEY POINTS

If the Manipulator will be used in a location that does not meet the above requirements, please contact the supplier.

WARNING

- Always use a circuit breaker for the Controller's power supply. Failure to use a circuit breaker may result in an electrical shock hazard or malfunction due to an electrical leakage. Select the correct circuit breaker based on the Controller that you are using. For details, refer to the following manual.

"Robot Controller Manual"

CAUTION

- When cleaning the Manipulator, do not rub it strongly with alcohol or benzene. Coated surfaces may lose their luster.

3.3.2 Manipulator Mounting Dimensions

Mounting Area

Also, besides the area required for installation of the Manipulator, Controller, peripheral equipment, and other devices, the following space should be provided at a minimum.

- Space for teaching
- Space for maintenance and inspections (for installing jigs and working safely within the safety barriers)
- Space for cables

KEY POINTS

- When installing the cables, be sure to maintain sufficient distance from obstacles.
- For the minimum bend radius of the M/C cable, refer to the following section.

C8 Specifications

- Also, leave enough space for other cables so that they are not forced to bend at extreme angles.

KEY POINTS

For C8-B1401*** (C8XL): Make sure to leave 35 mm or more space around the fan cover.

3.3.2.1 Cable backward model

(Units: mm)

C8-B901* (C8L)**

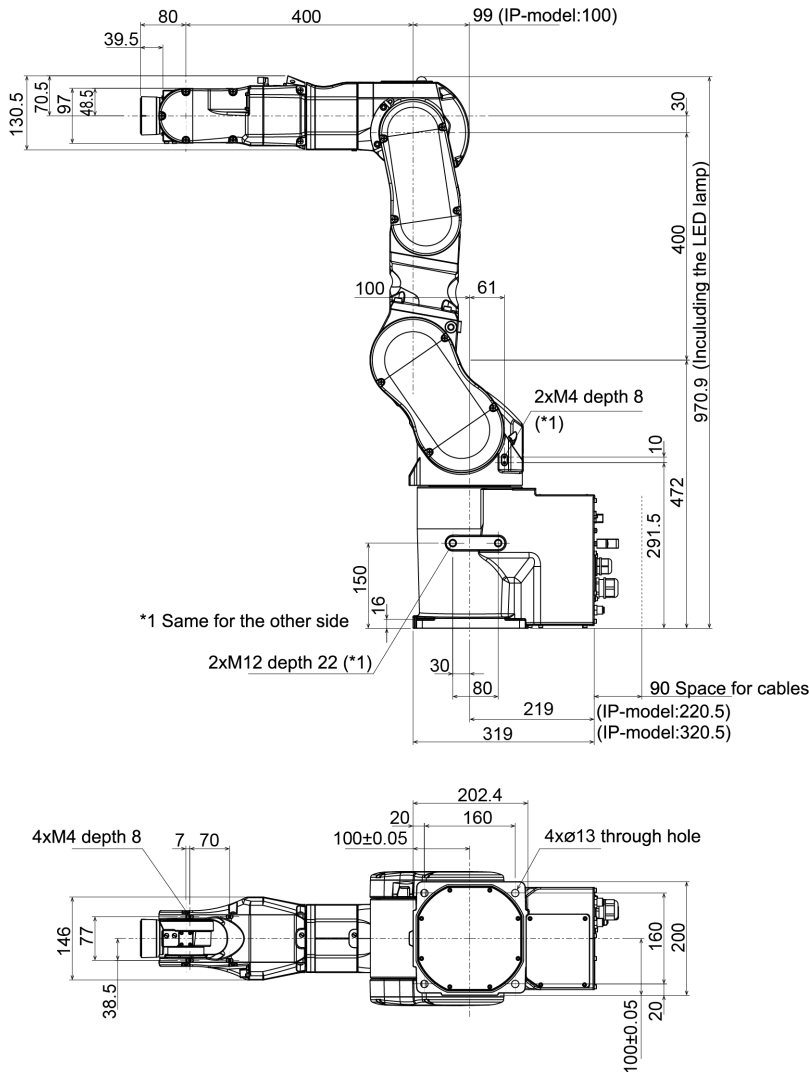

depth = depth of threaded hole

C8-B1401* (C8XL)**

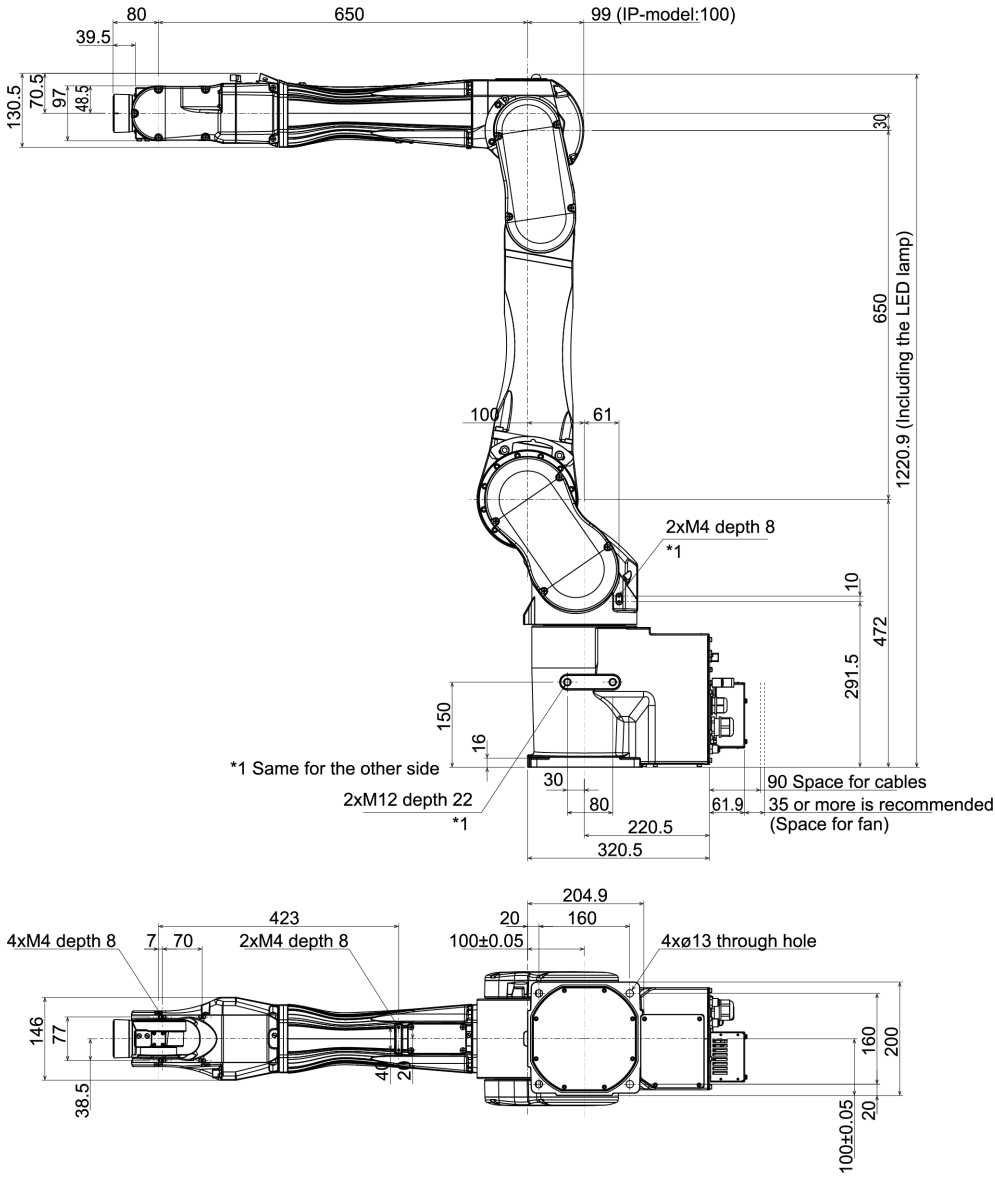

depth = depth of threaded hole

3.3.2.2 Cable downward model

The following part differs from the cable backward model.

C8-B901**B (C8L)

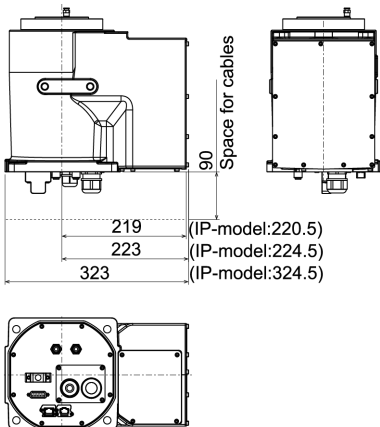

C8-B1401B (C8XL)**

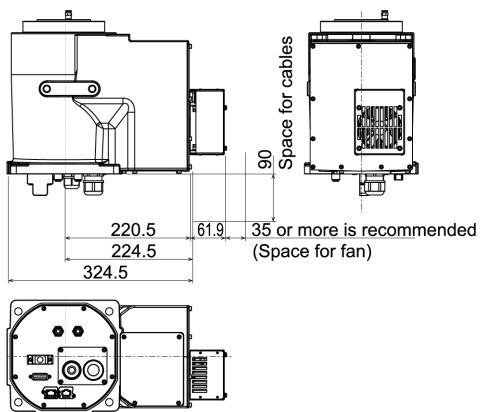

3.3.3 From Unpacking to Installation

Transportation and installation of the Manipulator and related equipment should be performed by people who have received installation training provided by Epson and the suppliers. Also, the laws and regulations of the installation country must be followed.

⚠ WARNING

- Only qualified personnel should perform sling work and operate a crane or a forklift. When these operations are performed by unqualified personnel, it is extremely hazardous and may result in serious bodily injury and/or severe equipment damage to the robot system
- When hoisting the Manipulator, use your hands to balance it. Losing balance may cause the Manipulator to drop, which is extremely hazardous and may result in serious injury and/or severe damage to the robot system.
- To ensure safety, be sure to install safeguards for the robot system. For more information on safeguards, refer to the following manual.
"Epson RC+ User's Guide - Safety - Installation and Design Precautions "
- Install the Manipulator in a location with sufficient space so that a tool or a work piece does not touch a wall or a safeguard when the Manipulator extends its arm fully while holding a work piece. If the tool or the workpiece tip reaches a wall or safeguards, it is extremely hazardous and may result in serious bodily injury and/or severe equipment damage to the robot system.
- Be sure to anchor the Manipulator before turning on the power or operating it. Turning on the power or operating the Manipulator while it is not anchored may cause the Manipulator to fall over, which is extremely hazardous and may result in serious injury and/or severe damage to the robot system.
- Before installing or operating the Manipulator, make sure that no parts of the Manipulator are missing and that it has no damage or other external defects. Missing parts or damage may cause malfunction of the Manipulator, is extremely hazardous, and may result in serious injury and/or severe equipment damage to the robot system.

⚠ CAUTION

- Use a cart or the like to transport the Manipulator in the same status as it was delivered.
- When removing the fixing bolts securing the Manipulator to the transportation pallet and the packing box or the anchor bolts, support the Manipulator to prevent it falling. Removing the fixing bolts or anchor bolts without supporting the Manipulator may cause it to fall, catching your hands or feet.
- The Manipulator should be transported by two or more people or secured to transporting equipment. Also, do not hold the bottom of the base (the screened parts in the figure). Holding these parts by hand is extremely hazardous and may cause your hands and fingers caught.

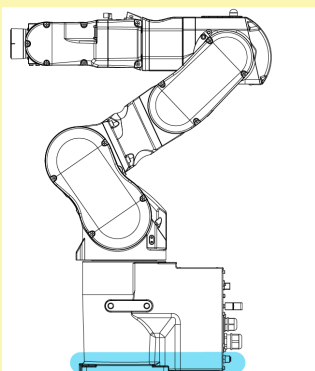

Manipulator weight

	C8-B901***: C8L	C8-B1401***: C8XL
Standard, Cleanroom Model	53 kg: 117 lb	63 kg: 139 lb
Protected-Model	57 kg: 126 lb	66 kg: 146 lb

- Take extra care when transporting the Manipulator. You may hit and damage the connector.



- During unpacking and relocation, avoid applying external force to the arms and motors of the Manipulator.
- When transporting the Manipulator over long distances, secure it directly to transporting equipment so that it will not fall. If necessary, pack the Manipulator using the same packaging as delivery.
- The Manipulator must be installed to avoid interference with surrounding buildings, structures, and other machines and equipment that may create a trapping hazard or pinch points.
- Resonance (resonating sound or minute vibrations) may occur during Manipulator operation depending on the rigidity of the base table. If the resonance occurs, improve the rigidity of the base table or change the speed or acceleration and deceleration settings of the Manipulator.
- C8-B1401** has a cooling fan on the base. Install the Manipulator not to seal the cooling fan. For details, refer to the following figure.
 - [Cable backward model](#)
 - [Cable downward model](#)

Protective tape

Remove the protective tape (4 places).

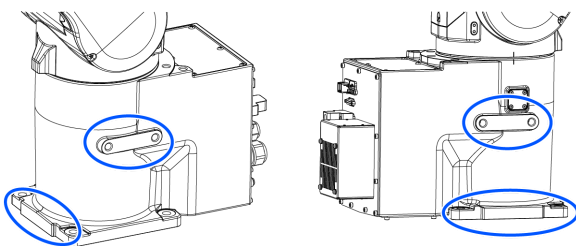

Fixing bolt

For details on the dimensions, refer to the following sections.

[Manipulator Mounting Dimensions](#)

There are four threaded holes for the Manipulator base. Use M12 mounting bolts conforming to the strength equivalent to ISO898-1 property class 10.9 or 12.9. Tightening torque: $100.0 \pm 5.0 \text{ N}\cdot\text{m}$ ($1,020 \pm 51 \text{ kgf}\cdot\text{cm}$)

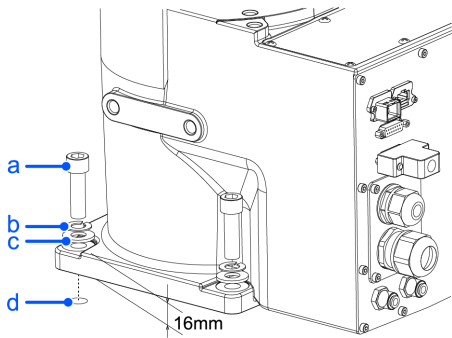

Symbol	Description
a	4×M12×40
b	Spring washer
c	Plain washer
d	Threaded hole (25 mm or more depth)

Base table

A base table for anchoring the Manipulator is not supplied. The base table must be fabricated or obtained by the customer.

The shape and size of the base table vary depending on the application of the robot system. As a reference when designing the base table, the requirements from the Manipulator side are shown here.

The base table must not only be able to bear the weight of the Manipulator but also be able to withstand the dynamic movement of the Manipulator when it operates at maximum acceleration/deceleration. Ensure that there is enough strength on the base table by attaching reinforcing materials such as crossbeams.

Followings are the torque and reaction force produced by the movement of the Manipulator.

Model Number	C8-B901 ***	C8-B1401***
Model Name	C8L	C8XL
Maximum rotating torque on horizontal surface (N·m)	1800	2600
Maximum reaction force in horizontal direction (N)	1300	1300
Maximum rotating torque on vertical surface (N·m)	2200	3400
Maximum reaction force in vertical direction (N)	6000	7800

The plate for the Manipulator mounting face should be at least 30 mm thick and made of steel for reducing vibrations.

A surface roughness of 25 μm or less at the maximum height is appropriate.

The base table must be secured on the floor to prevent it from moving.

The Manipulator installation surface should have a flatness of 0.5 mm or less and an inclination of 0.5° or less. If the installation surface does not have the proper flatness, the base of the Manipulator may be damaged or the robot may be unable to operate at maximum performance.

When using a leveler to adjust the height of the base table, use a screw with M16 diameter or more.

Connector

If passing cables through the holes in the base table, refer to the connector dimensions in the figures below. (Units: mm)

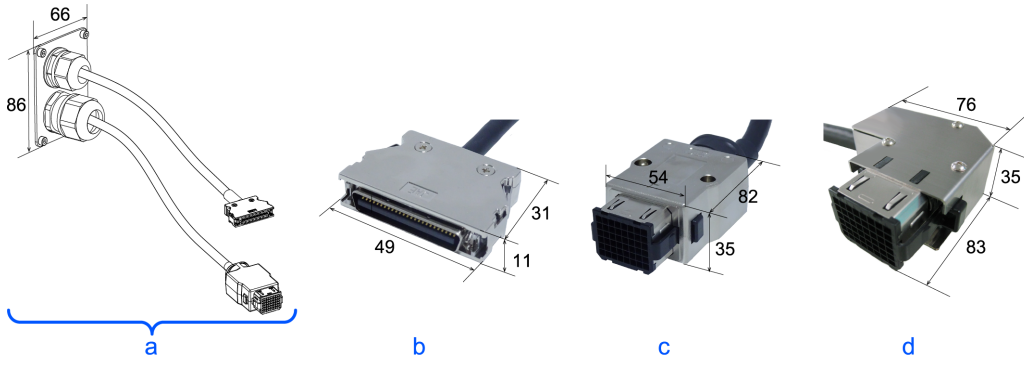

Symbol	Description
a	M/C cable
b	Signal cable connector
c	Power cable connector (straight)
d	Power cable connector (L-shaped)

Do not remove the M/C cables from the Manipulator.

KEY POINTS

For details on the environmental requirements for the space when housing the Controller in the base table, refer to the Robot Controller manual.

When using the Manipulator in the clean room, follow the steps below before the installation.

1. Unpack the Manipulator outside of the cleanroom.
2. Secure the Manipulator to transporting equipment (or a pallet) with bolts so that the Manipulator does not fall down.
3. Wipe off any dust on the Manipulator using a lint-free cloth that was dipped in ethyl alcohol or distilled water.
4. Carry the Manipulator into the cleanroom.
5. Secure the Manipulator to the base table.

3.3.4 Connecting the Cables

WARNING

- Before performing any replacement work, turn off the Controller and related equipment, and unplug the power cable from the power source. Performing any work procedure with the power turned on is extremely dangerous and may result in electric shock and/or malfunction of the robot system.
- Be sure to connect the AC power cable to a power outlet. Do not connect it directly to a factory power source. To perform the power supply lockout, remove the power plug. Working while connecting the AC power cable to a factory power source may result in electric shock and/or malfunction of the robot system.
- Be sure to connect the cables properly. Do not put heavy objects on the cables, bend or pull on the cables forcibly, or allow the cables to be pinched. Damaged cables, broken wires, or contact failure is extremely hazardous and may result in electric shock and/or malfunction of the robot system.
- Be sure to turn off the power and tag out (e.g., with a "DO NOT TURN ON" sign) before performing wiring. Performing any work procedure with the power turned on is extremely dangerous and may result in electric shock and/or malfunction of the robot system.
- The Manipulator is grounded by connecting it to the Controller. Ensure that the Controller is grounded and the cables are correctly connected. If the ground wire is improperly connected to ground, it may result in the fire or electric shock.
- Turn off the power to the Robot Controller and brake release unit when connecting or replacing the brake release unit or external short connector. Inserting or removing connectors with the power on may result in electric shock and/or malfunction of the robot system.

CAUTION

- When connecting the Manipulator and the Controller, check that the serial numbers match for each device. Improper connection between the Manipulator and the Controller may not only lead to malfunction of the robot system but also safety problems. The connection method between the Manipulator and the Controller varies depending on the Controller. For details on the connection, refer to the following manual.

"Robot Controller Manual"

- Only authorized or certified personnel should perform wiring. Wiring by unauthorized or uncertified staff may result in bodily injury and/or malfunction of the robot system.
- Operating the Manipulator without a brake release unit or external short connector connected may cause the brake to fail to release, possibly damaging the brake.

After using the brake release unit, be sure to connect the external short circuit connector to the Manipulator or make sure to leave the connector for the brake release unit connected.

Cleanroom-model Manipulator

When the Manipulator is a model with cleanroom specifications, an exhaust system must be connected. For the exhaust system, refer to the following section.

C8 Specifications

Protected-model Manipulator

When the Manipulator is a protected-model, please note the following points.

⚠ CAUTION

- When operating Manipulators in special environments (oil smoke, dust, etc.), do not install the Controller in the same environment. The Controller does not satisfy the protection class (IP67). Using the Controller in these special environments may damage or lead to a breakdown of the Controller.
- After using the brake release unit, be sure to reconnect the external short connector to the Manipulator. The break release unit does not satisfy the protection class (IP67).
- Be sure to connect a connector compliant with protection class IP67 or higher and a connector cover to the Ethernet cable connector.

Connection procedure for M/C cable

Connect the power connector and signal connector of the M/C cable to the Controller.

3.3.5 User Wires and Pneumatic Tubes

⚠ CAUTION

- Only authorized or certified personnel should perform wiring. Wiring by unauthorized or uncertified staff may result in bodily injury and/or malfunction of the robot system.

User electrical wires and pneumatic tubes are contained in the cable unit.

Cable backward model

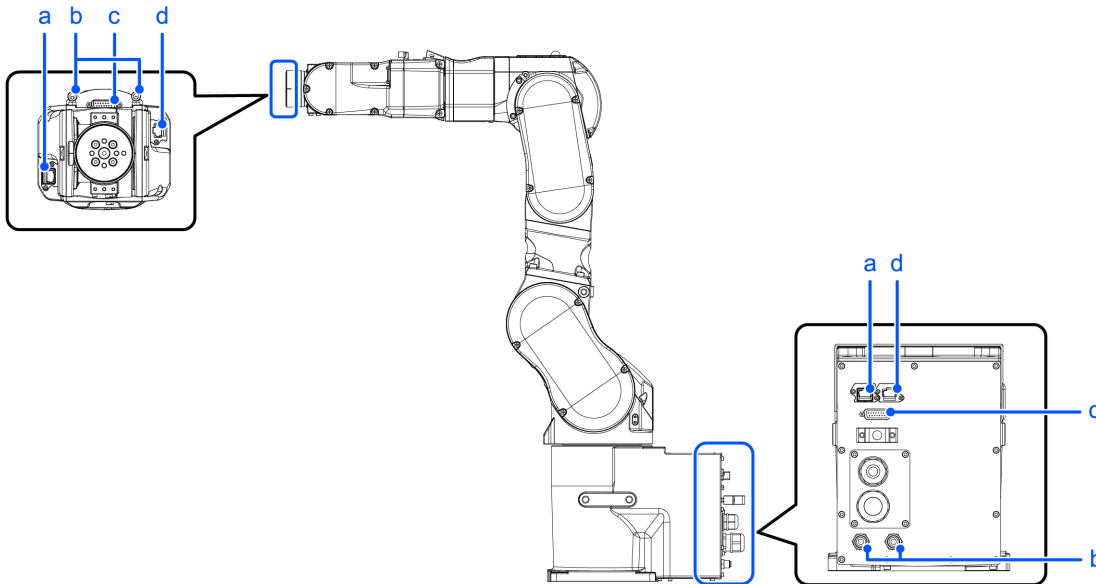

Cable downward model

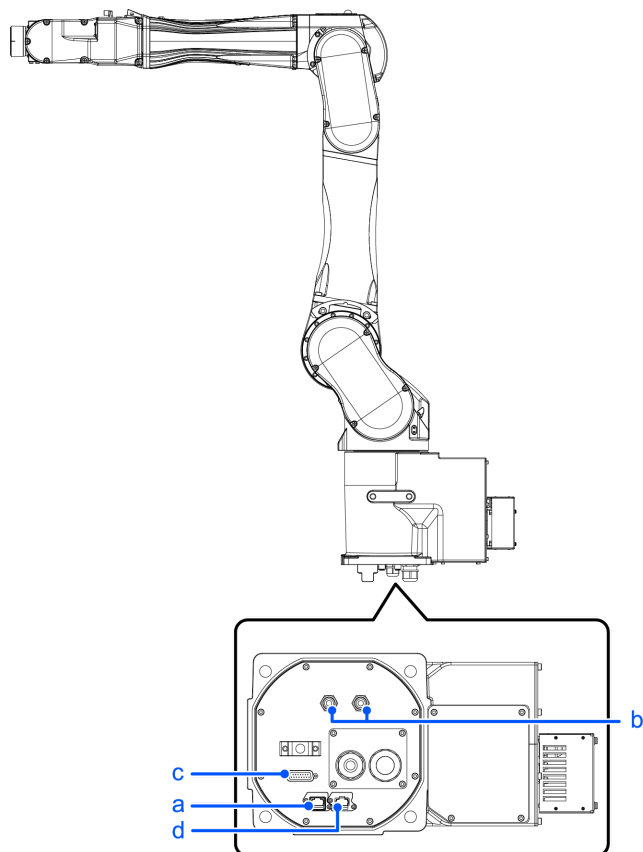

Symbol	Description
a	Force Sensor cable connector
b	Fitting for $\varnothing 6$ mm tube (Air1, Air2)
c	User cable connector (9-pin D-sub connector)
d	Ethernet cable connector

3.3.5.1 Electrical Wires

Specifications of the user wires D-sub 15-pin

Rated Voltage	Allowable Current	Wires	Nominal Sectional Area	Note
AC/DC30V	1 A	15	0.106 mm ²	Shielded

Pins with the same number, indicated on the connectors on both ends of the cables, are connected.

Attached connector for user wires (standard, cleanroom model)

		Manufacturer	Type	
15 pin	Connector	JAE	DA-15PF-N	(Solder type)
	Clamp hood	HRS	HDA-CTH (4-40) (10)	(Connector setscrew: #4-40 UNC)

Two parts are attached for each.

Attached connector for user wires (protected-model)

		Manufacturer	Type	
15 pin	Connector	HARTING	09 67 015 5615	(Solder type)
	Clamp hood	HARTING	09 67 015 0538	(Connector setscrew: #4-40 UNC)

Two parts are attached for each.

8-pin (RJ45) equivalent to Cat.5e

An Ethernet cable (commercially available) can be connected to Manipulator models with standard and cleanroom specifications.

For the protected-model, use the following optional part.

User connector kit (IP67 waterproof, for RJ45, 2 pcs)

For details, refer to the following section.

Options

Other

The 6-pin cable for the Force Sensor option is included.

3.3.5.2 Pneumatic Tubes

Maximum Working Pressure	Number of Tubes	Outer Diameter × Inner Diameter
0.59 MPa (6 kgf/cm ² : 86 psi)	2	ø6 mm × ø4 mm

Standard model, Cleanroom model:

The elbow fitting is attached on the Arm #4 at the time of shipment. The part can be replaced with the straight fitting (accessory) according to application.

Protected-model:

The plugs are installed on the Arm #4 and the base. To use the pneumatic tubes, remove the plugs and install the fittings (accessory) on the Arm #4.

Threaded hole size for installing the Arm #4 fitting: M6

When the Manipulator is a protected-model, please note the following points.

⚠ CAUTION

- In special environments (e.g., oil smoke, dust, etc.), the user wires and pneumatic tubes should have protected-model (compliant with protection class IP67). If the user wires and pneumatic tubes not protected-model are connected, the protection class (IP67) cannot be guaranteed, and the Manipulator may be damaged or break down.
- Be sure to attach the cap or plug (attached at the time of shipment) on the user cable connector when not using the user cable connector or the pneumatic tubes. Using the Manipulator without the cap or plug may cause equipment damage to and/or malfunction of the Manipulator as dust or oily smoke gets into the connector.

3.3.6 Checking the Basic Orientation

After installing the Manipulator and setup the operating environment, check if it moves to the basic position properly.

Follow the steps below to set the basic orientation of the Manipulator shown below as the origin position.

1. Start Epson RC+.
 - Double click the [Epson RC+] icon on the desktop.
2. Open the command window.
 - Epson RC+ menu-[Tools]-[Command Window]
3. Execute the following command in [Command Window].

```
>Motor On
>Go Pulse (0,0,0,0,0,0)
```

KEY POINTS

If "Error 4505: cannot be turned on the motor because the Safety Board is issuing a stop signal." occurs, use one of the following methods to move the Manipulator to its basic orientation.

- Release the brake and push the arm by hand to move it within the motion range. Then follow the steps above. For details on releasing brake, refer to the following section.

How to Move Arms with the Electromagnetic Brake

- Press the TP3 or TP4 command button [Pulse0] to move the Manipulator to its basic orientation. For details, refer to the following manual.

For TP3:

"Robot Controller Option Teach Pendant TP3 Operation 3.1.3 Command Buttons"

For TP4:

"Robot Controller Option Teach Pendant TP4 3.2.5.13.2 Command Buttons"

"Robot Controller Option Teach Pendant TP4 3.2.9.7.2 Command Buttons"

If the Manipulator cannot be in the basic orientation shown below, please contact the supplier.

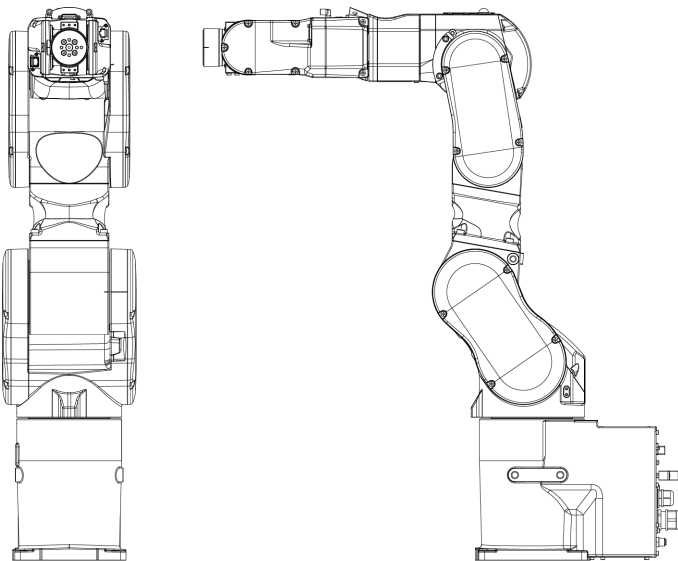

3.3.7 Relocation and Storage

3.3.7.1 Safety Information for Relocation and Storage

Pay attention to the following requirements when relocating, storing, and transporting the Manipulators.

Transportation and installation of the Manipulator and related equipment should be performed by people who have received installation training provided by Epson and the suppliers. Also, the laws and regulations of the installation country must be followed.

WARNING

- Only qualified personnel should perform sling work and operate a crane or a forklift. When these operations are performed by unqualified personnel, it is extremely hazardous and may result in serious bodily injury and/or severe equipment damage to the robot system

CAUTION

- Before relocating, fold the arm and secure it tightly with a cable tie to prevent hands or fingers from getting caught in the Manipulator.
- When removing the anchor bolts, support the Manipulator so that it does not fall. Removing the anchor bolts without supporting the Manipulator can cause it to fall, causing hands or feet to get caught.
- The Manipulator should be transported by two or more people or secured to transporting equipment. Also, do not hold the bottom of the base. Holding these parts by hand is extremely hazardous and may cause your hands and fingers caught.

During unpacking and relocation, avoid applying external force to the arms and motors of the Manipulator.

When transporting the Manipulator over long distances, secure it directly to transporting equipment so that it will not fall. If necessary, pack the Manipulator using the same packaging as delivery.

When the Manipulator is reassembled and used for a robot system again after an extended period of storage, perform a test run to verify that it works properly before starting the main operation.

Manipulators should be transported and stored under the following conditions: Temperature: -20 to +60°C, Humidity: 10 to 90% (no condensation)

If condensation has formed on the Manipulator during transportation or storage, do not turn on the power until the condensation is removed.

Do not subject the Manipulator to excessive impacts or vibrations during the transportation process.

Relocation

Follow the procedures described below when relocating the Manipulator.

1. Turn off the power for all devices and unplug the power cable connector and signal cable connector from the Controller.
Do not remove the M/C cables (power cable and signal cable) from the Manipulator.

KEY POINTS

Remove the mechanical stops if using them to limit the motion range. For details on the motion range, refer to the following section.

[Setting the Work Envelope by Mechanical Stops](#)

2. Unscrew the anchor bolts. Then, remove the Manipulator from the base table.
3. Position the Manipulator as shown in the figure. Then, secure the Manipulator to the transporting equipment or have at least two people to relocate the Manipulator. (Recommend: Joint #2 +55°. Joint #3 -55°)

The posture is common to all models.

Do not hold the bottom of the base (the screened parts in the figure). Holding these parts by hand is extremely hazardous and may cause your hands and fingers caught.

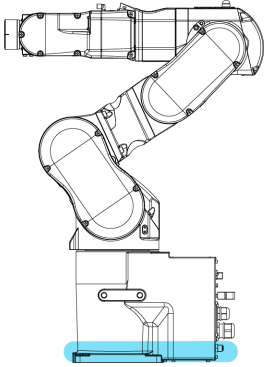

Manipulator weight

	C8-B901***: C8L	C8-B1401***: C8XL
Standard, Cleanroom Model	53 kg: 117 lb	63 kg: 139 lb
Protected-Model	57 kg: 126 lb	66 kg: 146 lb

Using eyebolts

Check that the eyebolts are securely fastened before transporting the Manipulator. After transporting the Manipulator, remove the eyebolts and keep them for future use.

The eyebolts (accessory, 2 pcs) and wire must be strong enough to withstand the weight (See the figures below).

If you use the eyebolts to lift up the Manipulator, make sure to put hands on it to keep the balance. The Manipulator may fall if the balance is lost and this is extremely hazardous.

To prevent damage on the covers and arms, it is recommended to protect the contacting parts of the wire and arm with a cloth. Be very careful not to damage the covers since they are made of plastic.

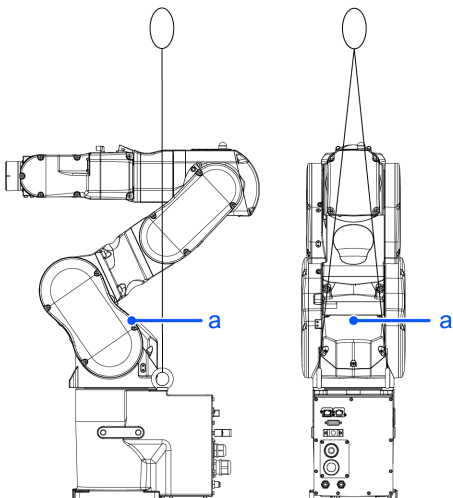

Symbol	Description
a	Center of gravity

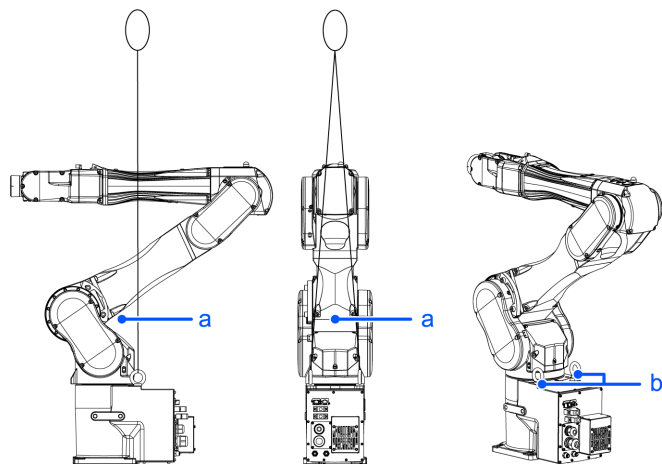

Symbol	Description
a	Center of gravity
b	Threaded holes for eyebolts: 2×M12 depth 25

Locations of the threaded holes for eyebolts are common to all models.

Manipulator weight

	C8-B901***: C8L	C8-B1401***: C8XL
Standard, Cleanroom Model	53 kg: 117 lb	63 kg: 139 lb
Protected-Model	57 kg: 126 lb	66 kg: 146 lb

⚠ CAUTION

- Remove the eyebolts from the Manipulator after transportation/relocation is completed. If the Manipulator is operated with the eyebolts left on it, the arm may collide with the eyebolts and it may cause equipment damage to and/or malfunction of the Manipulator.

3.4 Setting the Hand

3.4.1 Installing the Hand

The hand (end effector) must be prepared by the customer. For details on attaching the hand, refer to the following manual. "Hand Function Manual"

Flange dimensions of the wrist attached to the end of Arm #6 is as below.

⚠ WARNING

- Before attaching a hand or peripheral equipment, be sure to always turn off the Controller and related equipment and unplug the power cables. Performing any work procedure with the power turned on is extremely dangerous and may result in electric shock and/or malfunction of the robot system.

⚠ CAUTION

- When the hand is equipped with a workpiece gripping mechanism, ensure that the wiring and pneumatic tubes do not cause the hand to release the workpiece when the power is turned off. When the wiring and pneumatic tubes are not designed for the hand to maintain its grip on the workpiece when the power is turned off, pressing the emergency stop switch releases the workpiece, which may damage the robot system and the workpiece.

By default, all I/Os are designed to automatically turn off (0) when the power is shut off, when an emergency stop is triggered, or by the robot system's safety function.

However, I/Os set with the Hand function does not turn off (0) when executing the Reset statement, or when performing an emergency stop.

For the risk of the residual air pressure, conduct a risk assessment on the equipment and take the necessary protective measures.

Wrist flange

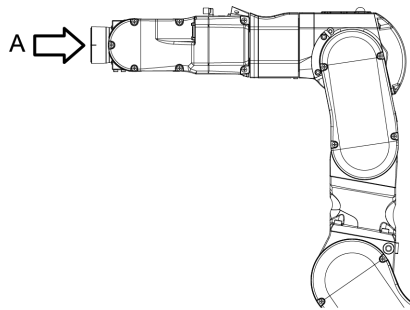
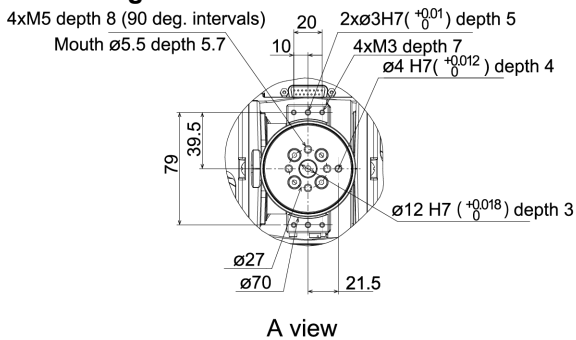

Arm #6

Attach the hand to the end of the Arm #6 using the M5 bolts.

Layout

When attaching and operating a hand, the hand may come into contact with the Manipulator body due to the outer diameter of the hand, the size of the workpiece, or the position of the arm. Carefully consider the interference area of the hand when designing the system layout.

Compatibility with ISO flange

To install the hand whose mounting dimensions are designed for the ISO flange, we provide the optional C8 ISO flange (J6). For details, refer to the following section.

Options

3.4.2 Attaching Cameras and Valves

Decks are equipped to Arms #3 and #5 to enable the easy installation of air valve. If the payload exceeds the maximum payload, refer to the following section.

"**WEIGHT Setting** - Restrictions on payload exceeding the maximum payload"

To mount the camera, the camera plate unit is necessary. We provide the optional Camera Plate Unit. For details, refer to the following section.

Options

(Units: mm)

C8-B901* (C8L)**

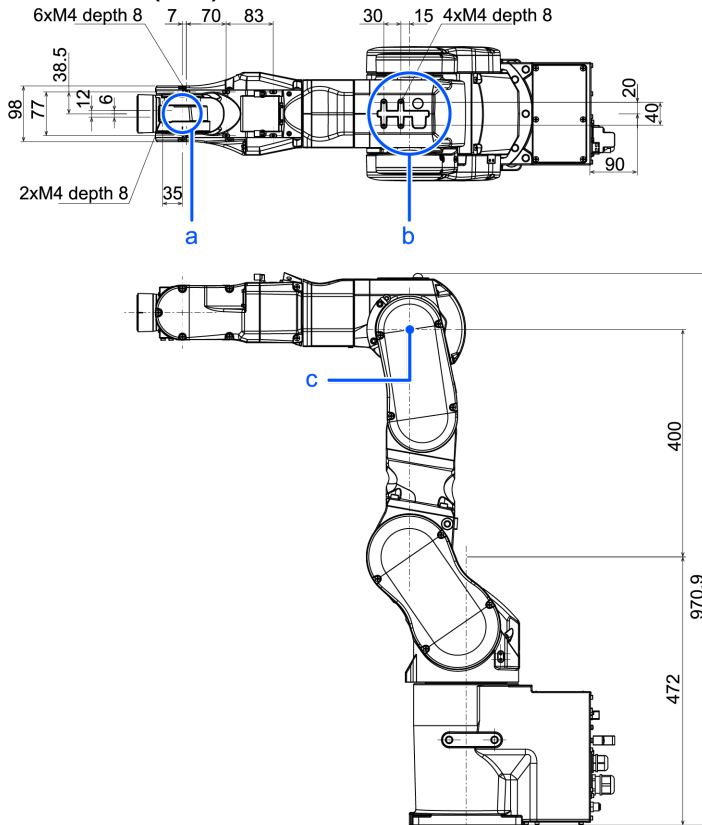

Symbol	Description
a	Arm #5 Deck
b	Arm #3 Deck
c	Rotation center of the upper arm

C8-B1401* (C8XL)**

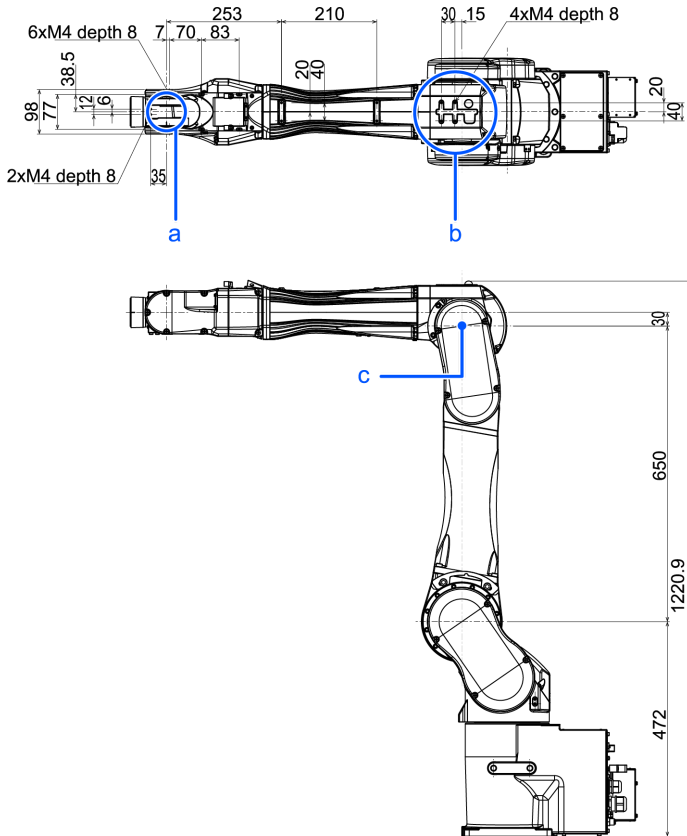

Symbol	Description
a	Arm #5 Deck
b	Arm #3 Deck
c	Rotation center of the upper arm

3.4.3 WEIGHT and INERTIA Settings

The WEIGHT and INERTIA commands are for setting the load parameters of the Manipulator. These settings optimize the Manipulator motion.

- **WEIGHT Setting**
The WEIGHT command is for setting the load weight. The more the load weight increases, the more the speed and acceleration/deceleration are reduced.
- **INERTIA Setting**
The INERTIA command is for setting the inertia moment and the eccentricity of the load. The more the inertia moment increases, the more the acceleration and deceleration of the Arm #6 are reduced. The more the eccentricity increases, the more the acceleration and deceleration for the Manipulator movement are reduced.

To ensure that the Manipulator is functioning properly, keep the load (the sum of the weights of the hand and workpiece) and the moment of inertia of the load within the rated values, and do not allow for eccentricity from the center of the Arm #6. If the load or the inertia moment exceeds the ratings or if the load becomes eccentric, follow the steps below to set parameters.

- **WEIGHT Setting**
- **INERTIA Setting**

Setting parameters makes the operation of the Manipulator optimal, reduces vibration to shorten the operating time, and improves the capacity for larger loads. This also works to curb any persistent vibration that may occur when the hand and workpiece have a large moment of inertia.

You can also perform settings using the "Weight, Inertia, and Eccentricity/Offset Measurement Utility."

For details, refer to the following manual.

"Epson RC+ User's Guide - Weight, Inertia, and Eccentricity/Offset Measurement Utility"

The allowable load for C8 series Manipulators is up to 8 kg.

Due to the limitations of the moment and moment of inertia shown in the table below, the load (hand + workpiece) should also meet these conditions.

Allowable Load

Joint	Allowable moment	(GD ² /4) Allowable Moment of Inertia
Joint #4	16.6 N·m (1.69 kgf·m)	0.47 kg·m ²
Joint #5	16.6 N·m (1.69 kgf·m)	0.47 kg·m ²
Joint #6	9.4 N·m (0.96 kgf·m)	0.15 kg·m ²

Moment

The moment indicates amount of torque applied on the joint in order to support the gravity on the load hand + workpiece). The moment increases as weight of the load and amount of eccentricity increase. As this also increases the load applied on the joint, make sure to keep the moment within the allowable value.

Moment of inertia

The moment of inertia indicates how difficult the load (hand + workpiece) to rotate when the Manipulator joint starts to rotate (amount of inertia). The moment of inertia increases as weight of the load and amount of eccentricity increase. As this also increases the load applied on the joint, make sure to keep the moment within the allowable value.

The moment M (Nm) and moment of inertia I (kgm²) when the volume of the load (hand + workpiece) is small can be obtained by the following formula.

$$M (Nm) = m (kg) \times L (m) \times g (m/s^2)$$

$$I (kgm^2) = m (kg) \times L^2 (m)$$

- m: Weight of load (kg)
- L: Eccentricity of load (m)
- g: Gravitational acceleration (m/s²)

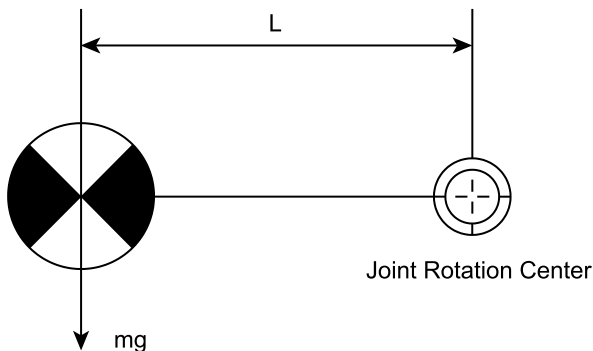

The figure below shows distribution of the center of gravity when the volume of the load (hand + workpiece) is small. Design the hand so that the center of gravity is within the allowable moment. If the volume of the load is large, calculate the moment and inertia moment by referring to the following section.

"**INERTIA Setting** - Calculating the Moment of Inertia"

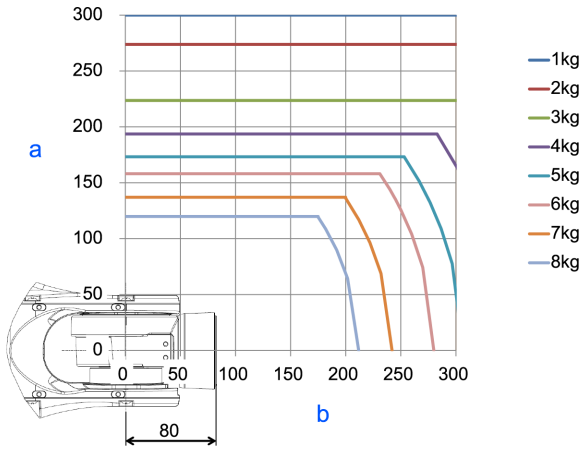

Symbol	Description
a	Distance from the center of Arm #* rotation [mm]
b	Center of gravity of load from the Arm #* rotation center [mm]

Max. Eccentricity of Load (Distance between the joint rotation center and the load’s center of gravity)

Joint	1 kg	2 kg	3 kg	4 kg	5 kg	6 kg	7 kg	8 kg
#4	300 mm	300 mm	300 mm	300 mm	300 mm	280 mm	242 mm	212 mm
#5	300 mm	300 mm	300 mm	300 mm	300 mm	280 mm	242 mm	212 mm
#6	300 mm	274 mm	224 mm	194 mm	173 mm	158 mm	137 mm	120 mm

When calculating the critical dimension of the load using the allowable moment and inertia moment, the calculated value represents a distance from the Arm #6 rotation center, not the distance from the flange. To calculate the distance from the flange to the load’s center of gravity, subtract the distance from the center of the Arm #5 rotation center to the flange (=80 mm) as shown in the example below.

Example: Calculation of the critical dimension of the load (A) when the load is 8 kg.

Center of gravity by the allowable moment control: $16.6 \text{ N}\cdot\text{m} / (8 \text{ kg} \times 9.8 \text{ m/s}^2) = 0.212 \text{ m} = 212 \text{ mm}$

Center of gravity by the allowable inertia moment control: $(0.47 \text{ kgm}^2 / 8 \text{ kg})^{1/2} = 0.242 \text{ m} = 242 \text{ mm}$

Due to the allowable moment control, center of gravity for the load limit is 212 mm from the Arm #5 rotation center.

Distance from the flange to the center of gravity for the load limit $A = 212 \text{ mm} - 80 \text{ mm} = 132 \text{ mm}$

Critical Dimension of Load

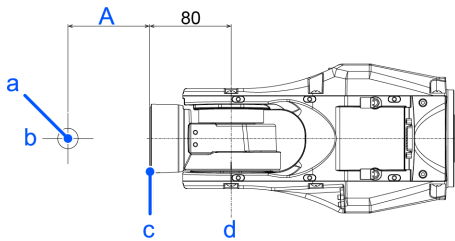

(Units: mm)

Symbol	Description
a	Load center of gravity position

Symbol	Description
b	Arm #6 rotation center
c	Flange
d	Arm #5 rotation center

3.4.3.1 WEIGHT Setting

⚠ CAUTION

- Set the total weight of the hand and the workpiece smaller than the maximum payload. The C8 series Manipulators can operate without limitations on the condition unless and until the load exceeds this maximum payload. Always set the Weight parameters of the WEIGHT command according to the load. Setting a value smaller than the actual weight may cause errors or impact that not only impair full functionality but also shorten the life of the mechanical components.

The acceptable weight capacity (hand + workpiece) for C8 series Manipulators is as follows:

Rated	Maximum
3 kg	8 kg

Change the setting of the Weight parameter according to the load. After changing the Weight parameter setting, the maximum acceleration/deceleration and speed of the robot system is set automatically.

Setting method of Weight parameters

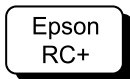

Select [Tools]-[Robot Manager]-[Weight] panel and set the value in [Weight:]. You may also execute the Weight command from [Command Window].

Load on the Manipulator

Mounting location of the load

C8-B901*** (C8L)

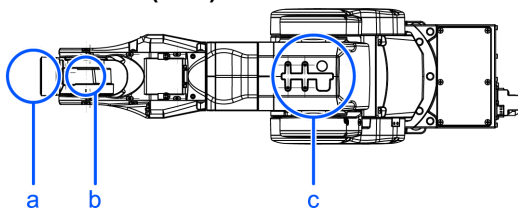

Symbol	Description
a	Load on the fore end of Arm #6
b	Arm #5 deck
c	Arm #3 deck

C8-B1401* (C8XL)**

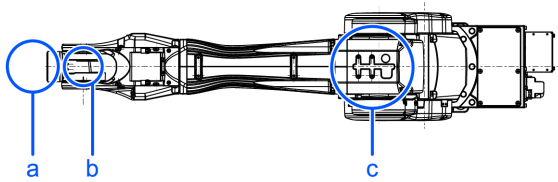

Symbol	Description
a	Load on the fore end of Arm #6
b	Arm #5 deck
c	Arm #3 deck

Deck detailed (Units: mm)

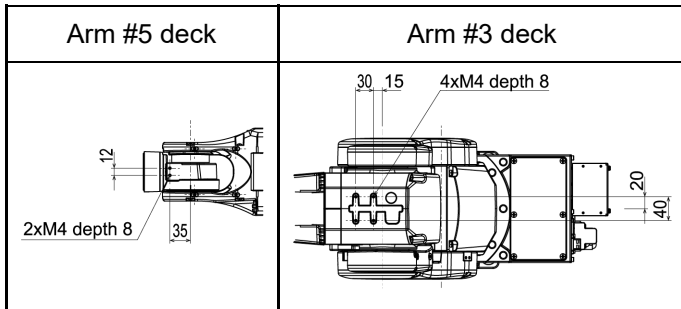

When you attach the equipment to the decks on the upper arm, convert its weight into equivalent weight assuming that the equipment is attached to the end of the Arm #6. Then, this equivalent weight added to the load will be a Weight parameter.

Calculate the Weight parameter by using the formula below and enter the value.

Weight Parameter Formula

Weight parameter = $M_w + W_a + W_b$

- M_w : Payload on the fore end of Arm #6 (kg)
- W_a : Equivalent weight of the Arm #3 deck (kg)
- W_b : Equivalent weight of the Arm #5 deck (kg)
- $W_a = M_a (L_a)^2 / (L)^2$
- $W_b = M_b (L_b)^2 / (L)^2$
- M_a : Weight of the air valve on the Arm #3 deck (kg)
- M_b : Weight of the camera on the Arm #5 deck (kg)
- L : Length of the upper arm (315 mm)
- L_a : Distance between the Joint #3 and the center of gravity of the air valve on the Arm #3 deck (mm)
- L_b : Distance between the Joint #3 and the center of gravity of the camera on the Arm #5 deck (mm)

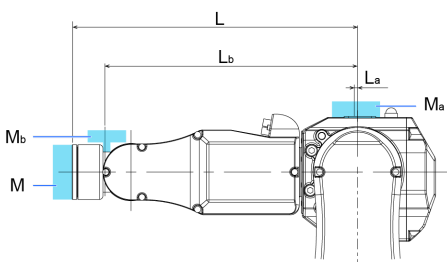

[Example] When the following loads apply to C8-B1401*** (C8XL) which fore end of the Arm #6 is 730 mm (L) away from the Joint #3 and payload (M_w) is 5 kg:

- Load on the Arm #3 deck is 1.5 kg (M_a). The deck is 0 mm (L_a) away from the Joint #3.
- Load on the Arm #5 deck is 1.0 kg (M_b). The deck is 690 mm (L_b) away from the Joint #3.

$$W_a = 1.5 \times 0^2 / 730^2 = 0$$

$$W_b = 1.0 \times 690^2 / 730^2 = 0.89 \rightarrow 0.9 \text{ (round up)}$$

$$M_w + W_a + W_b = 5 + 0 + 0.9 = 5.9$$

Enter "5.9" for the Weight parameter.

Automatic speed setting by Weight parameter

The percentage in the graph is based on the speed at rated weight (3 kg) as 100%.

C8-B901*** (C8L)

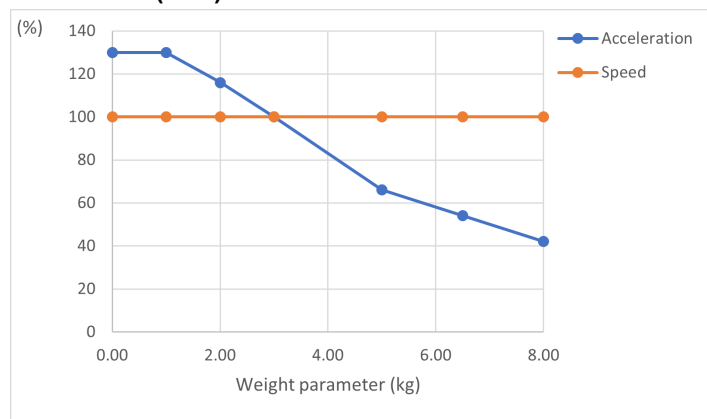

C8-B1401*** (C8XL)

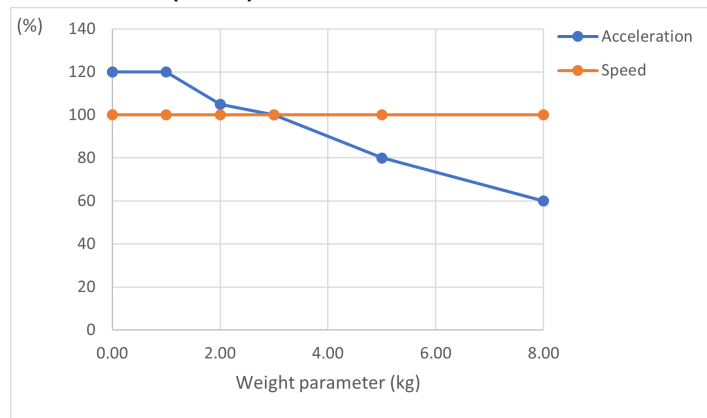

KEY POINTS

Maximum AccelS setting value varies depending on Weight setting value. For details, refer to the following section.

[C8 Specifications](#)

3.4.3.2 INERTIA Setting

Moment of Inertia and INERTIA Setting

The moment of inertia is a quantity that expresses how hard it is for an object to turn, and it is expressed in terms of values for the moment of inertia, inertia, or GD^2 . When a hand or other object is attached to the Arm #6 for operation, the moment of inertia of the load must be taken into consideration.

CAUTION

- The moment of inertia of the load (hand + workpiece) must be $0.15 \text{ kg}\cdot\text{m}^2$ or less.

The C8 Manipulators are not designed to work with a moment of inertia exceeding $0.15 \text{ kg}\cdot\text{m}^2$. Always set the value corresponding to the moment of inertia. Setting a parameter value that is smaller than the actual moment of inertia may cause errors or impact, may prevent the Manipulator from working at full functionality, and may shorten the lifespan of mechanical parts.

The allowable moment of inertia of a load for C8 Manipulators is $0.03 \text{ kg}\cdot\text{m}^2$ at the default rating and $0.15 \text{ kg}\cdot\text{m}^2$ at the maximum. Change the setting of the moment of inertia according to the inertia moment of the load using the INERTIA command. After the setting is changed, the maximum acceleration/deceleration of Arm #6 that corresponds to the "Inertia" value is corrected automatically.

Moment of Inertia of Load Attached to Arm #6

The moment of inertia of the load (hand + workpiece) attached to the Arm #6 can be set by the "Inertia" parameter in the Inertia statement.



Epson
RC+

Go to [Tools] - [Robot Manager] - [Inertia] panel, and enter the value in [Inertia]. This can also be set using the Inertia statement in [Command Window].

Eccentricity and INERTIA Setting

CAUTION

- The eccentricity of the load (hand + workpiece) must be 300 mm or less. The C8 series Manipulators are not designed to work with eccentricities exceeding 300 mm. Always set the value based on the eccentricity. Setting the eccentricity parameter to a value smaller than the actual eccentricity may cause errors or impact that not only impair full functionality but also shorten the life of the mechanical components.

The allowable eccentricity of load for C8 Manipulators is 50 mm at the default rating and 300 mm at the maximum. When the load eccentricity exceeds the rating, change the setting for the eccentricity parameter in Inertia statement. After the setting is changed, the maximum acceleration/deceleration of the Manipulator that corresponds to the "Eccentricity" is corrected automatically.

Eccentricity

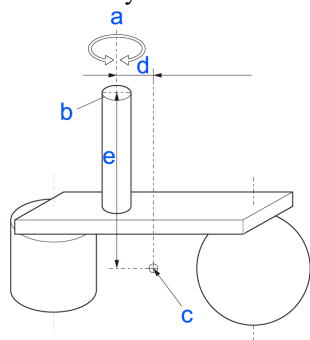

Symbol	Description
a	Rotation axis
b	Flange
c	Load center of gravity position
d, e	Eccentricity (300 mm or less) To set the parameter, enter the larger value of "d" or "e".

Eccentricity of Load Attached to Arm #6

The eccentricity of the load (hand + workpiece) attached to the Arm #6 can be set by the "Eccentricity" parameter in the Inertia statement.

Enter the larger value of either "d" or "e" in the figure above to [Eccentricity].

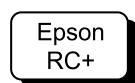

Go to [Tools] - [Robot Manager] - [Inertia] panel, and enter the value in [Eccentricity]. This can also be set using the Inertia statement in [Command Window].

Automatic Acceleration/Deceleration Correction at INERTIA (Eccentricity) Setting

Automatic setting by inertia moment setting (common to C8 series)

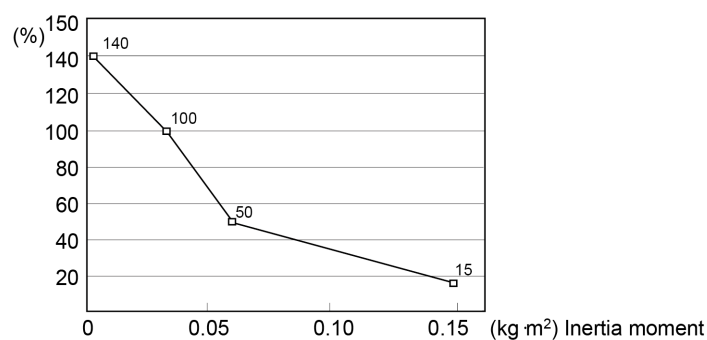

* The percentages on the graph are ratios based on 100% as the acceleration/deceleration at the rated (0.03 kg·m²) setting.

Automatic setting by eccentricity setting (common to C8 series)

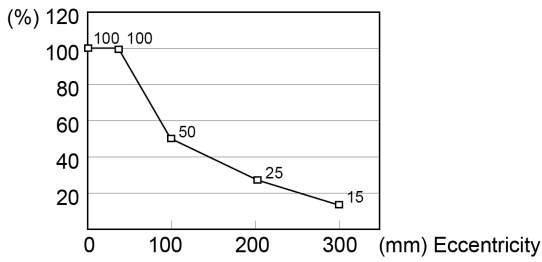

* The percentages on the graph are ratios based on 100% as the acceleration/deceleration at the rated (50 mm) setting.

Calculating the Moment of Inertia

An example of calculating the moment of inertia of a load (hand holding a workpiece) is shown below.

The moment of inertia of the entire load is calculated by the sum of (A), (B), and (C).

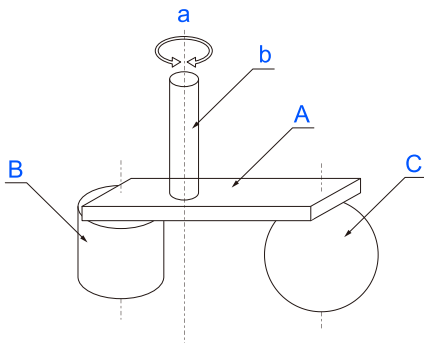

$$\text{Whole moment of inertia} = \text{Moment of inertia of end effector (A)} + \text{Moment of inertia of work piece (B)} + \text{Moment of inertia of work piece (C)}$$

Symbol	Description
a	Rotation axis
b	Shaft
A	Hand
B	Workpiece
C	Workpiece

The methods for calculating the moment of inertia for (A), (B), and (C) are shown below. Use the moment of inertia of these basic shapes as a reference to find the moment of inertia of the entire load.

(A) Moment of inertia of a rectangular parallelepiped

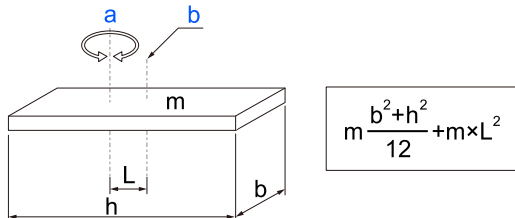

Symbol	Description
a	Rotation axis
b	Center of gravity of rectangular parallelepiped
m	Weight

(B) Moment of inertia of a cylinder

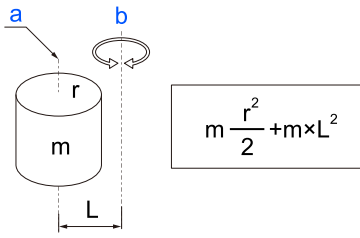

Symbol	Description
a	Center of gravity of cylinder
b	Rotation axis
m	Weight

(C) Moment of inertia of a sphere

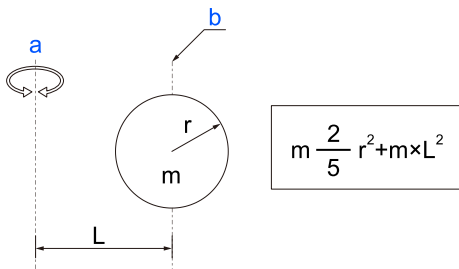

Symbol	Description
a	Rotation axis
b	Center of gravity of sphere
m	Weight

3.4.4 Safety Information for Auto Acceleration

The speed and acceleration/deceleration of the Manipulator motion are automatically optimized according to the values of WEIGHT and INERTIA and the Manipulator’s postures.

WEIGHT Setting

The speed and acceleration/deceleration of the Manipulator are controlled according to the load weight set by the WEIGHT command. The more the load weight increases, the more the speed and acceleration/deceleration are reduced to prevent residual vibration.

INERTIA Setting

The acceleration/deceleration of Arm #6 are controlled according to the inertia moment set by the INERTIA command. The acceleration/deceleration of the whole Manipulator are controlled according to the eccentricity set by the INERTIA command. The more the inertia moment and eccentricity of the load increase, the more the acceleration/ deceleration are reduced.

Auto Acceleration/Deceleration According to Manipulator’s Posture

The acceleration/deceleration are controlled according to the Manipulator’s posture. When the Manipulator extends its arms or when the movement of the Manipulator produces vibration frequently, the acceleration/deceleration are reduced.

Set appropriate values for WEIGHT and INERTIA so that the Manipulator operation is optimized.

3.5 Work Envelope

⚠ WARNING

- Do not operate the Manipulator with the mechanical stop removed. Removing the mechanical stop is extremely dangerous because the Manipulator may move to a position outside its normal work envelope.

⚠ CAUTION

- When restricting the work envelope for safety reasons, be sure to make settings using both the pulse range and mechanical stop.

The work envelope is preset at the factory as explained in the following section. This is the maximum work envelope of the Manipulator.

Standard Work Envelope

The work envelope can be set by one of the following three methods.

- Setting by pulse range (for each joint)
- Setting by mechanical stops
- Setting the rectangular range in the XY coordinate system of the Manipulator

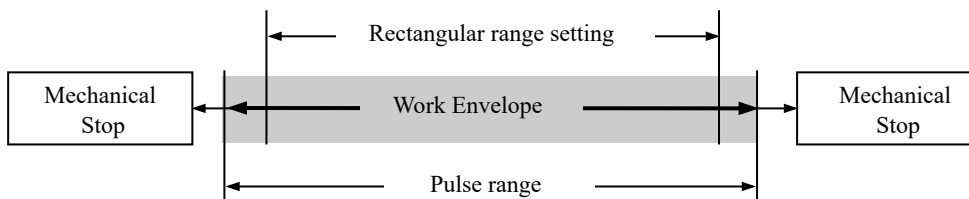

To limit the work envelope for layout efficiency or safety reasons, make the settings as explained in the following sections.

- Work Envelope Setting by Pulse Range (for Each Joint)**
- Setting the Work Envelope by Mechanical Stops**
- Restriction of Manipulator Operation by Joint Angle Combination**
- Coordinate System**

3.5.1 Work Envelope Setting by Pulse Range (for Each Joint)

Pulses are the basic unit of Manipulator motion. The motion range (work envelope) of the Manipulator is set by the pulse lower limit value and pulse upper limit value (pulse range) for each joint. Pulse values are read from the encoder output of the servomotor.

Be sure to set the pulse range within the mechanical stop range.

✎ KEY POINTS

- The Arm #1 and #4 do not have a mechanical stop.
- Once the Manipulator receives a motion command, it checks whether the target position specified by the command is within the pulse range before operating. If the target position is outside of the pulse range that was set, an error occurs and the Manipulator does not move.

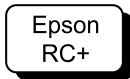

Go to [Tools] - [Robot Manager] - [Range] panel, and make the setting. This can also be set using the Range statement in [Command Window].

3.5.1.1 Joint #1 Maximum Pulse Range

With the 0 pulse as a starting point, the counterclockwise pulse value is defined as positive (+), and the clockwise pulse value is defined as negative (-).

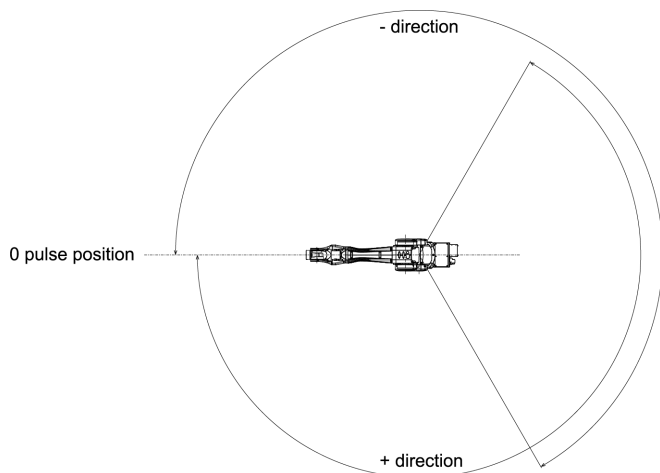

	C8-B901*** (C8L)	C8-B1401*** (C8XL)
Angle (°)	±240	
Pulse	±10695600	±15736800

3.5.1.2 Joint #2 Maximum Pulse Range

With the 0 pulse as a starting point, the clockwise pulse value is defined as positive (+), and the counterclockwise pulse value is defined as negative (-).

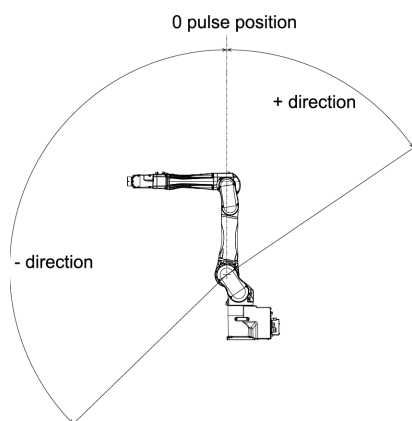

	C8-B901*** (C8L)	C8-B1401*** (C8XL)
Angle (°)	-158 to +65	-135 to +55
Pulse	-6903178 to +2839915	-10616940 to +4325420

3.5.1.3 Joint #3 Maximum Pulse Range

With the 0 pulse as a starting point, the clockwise pulse value is defined as positive (+), and the counterclockwise pulse value is defined as negative (-).

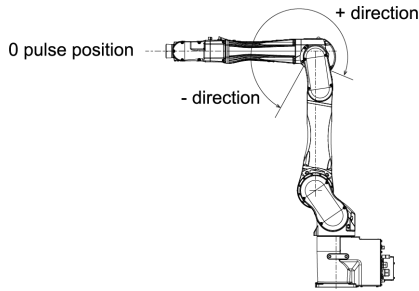

	C8-B901*** (C8L)	C8-B1401*** (C8XL)
Angle (°)	-61 to +202	
Pulse	-2220949 to +7354618	-3997696 to +13238272

3.5.1.4 Joint #4 Maximum Pulse Range

From the angle of arm end, with the 0 pulse as a starting point, the clockwise pulse value is defined as positive (+), and the counterclockwise pulse value is defined as negative (-). The max. pulse range of the Arm #4 is common to C8 series Manipulators.

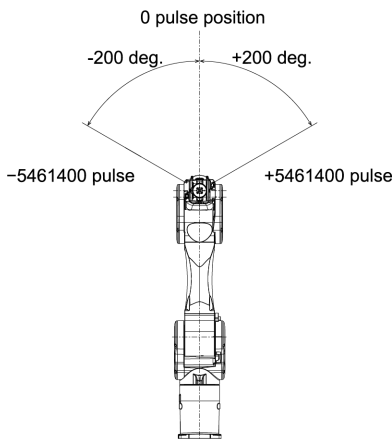

(deg.=°)

3.5.1.5 Joint #5 Maximum Pulse Range

With the 0 pulse as a starting point, the clockwise pulse value is defined as positive (+), and the counterclockwise pulse value is defined as negative (-). The max. pulse range of the Arm #5 is common to C8 series Manipulators.

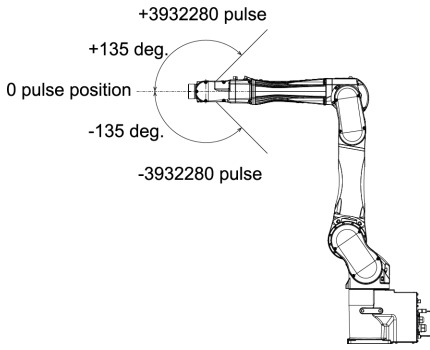

(deg.=°)

3.5.1.6 Joint #6 Maximum Pulse Range

From the angle of arm end, with the 0 pulse as a starting point, the clockwise pulse value is defined as positive (+), and the counterclockwise pulse value is defined as negative (-). The max. pulse range of the Arm #6 is common to C8 series Manipulators.

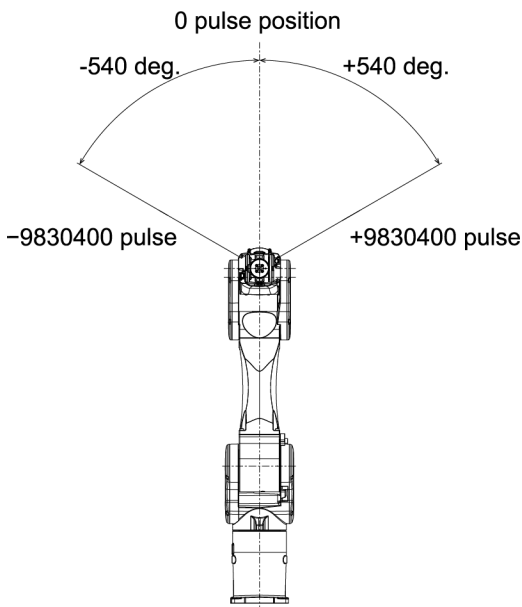

(deg.=°)

3.5.2 Setting the Work Envelope by Mechanical Stops

Using the variable mechanical stops physically limits the absolute area that the Manipulator can move.

Before starting any work, be sure to turn off the Manipulator.

Use bolts conforming to the specified length and surface processing (ex: nickel plating) with high corrosion resistance.

Specify the pulse range again after changing the position of the mechanical stop.

For details on the pulse range setting, refer to the following section.

[Work Envelope Setting by Pulse Range \(for Each Joint\)](#)

Be sure to set the pulse range inside the positions of the mechanical stop range.

3.5.2.1 Setting the Joint #1 Work Envelope

Install variable mechanical stop (J1) in the threaded holes corresponding to the angles to be set.

Normally a mechanical stop is not equipped.

- Hexagon socket head cap bolt: M12 × 30 × 2 bolts
- Strength: Compliant with ISO 898-1 property class: 10.9 or 12.9
- Tightening torque: 42.0 ± 2.1 N·m (428 ± 21 kgf·cm)

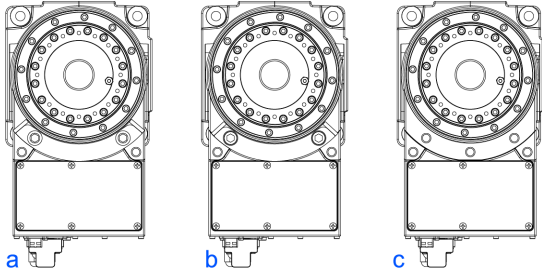

		a	b	c
Angle (°)		±110	±105	±240
Pulse	C8-B901*** (C8L)	±4902150	±4679271	±10695600
	C8-B1401*** (C8XL)	±7212700	±6884840	±15736800
Variable Mechanical Stop (J1)		Applied	Applied	Not applied (standard)

3.5.2.2 Setting the Joint #2 Work Envelope

C8-B901*** (C8L)

Remove the mechanical stop installed as standard and install the variable mechanical stop (C8/C8L_J2). (Joint #2 standard work envelope -158 to +65°)

- Hexagon socket head cap bolt: M10 × 35 × 1 bolts
- Strength: Compliant with ISO 898-1 property class: 10.9 or 12.9
- Tightening torque: 32.0 ± 1.6 N·m (326 ± 16 kgf·cm)

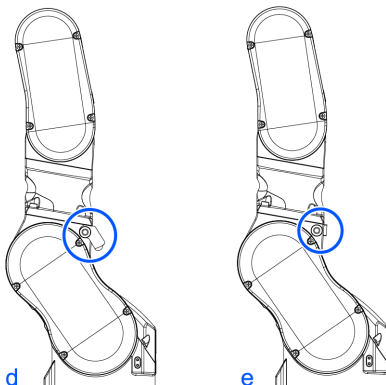

		d	e
Angle (°)		-158, +30	-158, +65
Pulse	C8-B901*** (C8L)	-6903178, +1310730	-6903178, +2839915
Variable mechanical stop (C8/C8L_J2)		Applied	Applied (standard)

C8-B1401* (C8XL)**

Remove the mechanical stop installed as standard and install the variable mechanical stop (C8XL_J2). (Joint #2 standard work envelope -135 to +55°)

- Hexagon socket head cap bolt: M10 × 35 × 2 bolts
- Strength: Compliant with ISO 898-1 property class: 10.9 or 12.9
- Tightening torque: 32.0 ± 1.6 N·m (326 ± 16 kgf·cm)

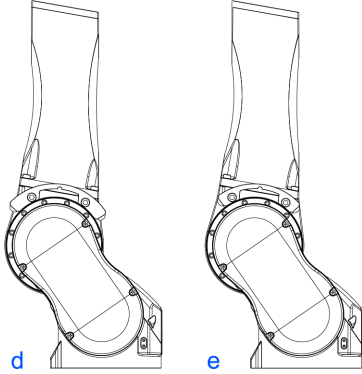

		d	e
Angle (°)		-125, +45	-135, +55
Pulse	C8-B1401*** (C8XL)	-9830500, +3538980	-10616940, +4325420
Variable mechanical stop (C8XL_J2)		Applied	Applied (standard)

3.5.2.3 Setting the Joint #3 Work Envelope

Remove the mechanical stop installed as standard and install the variable mechanical stop (J3). (Joint #3 standard work envelope -61 to +202°)

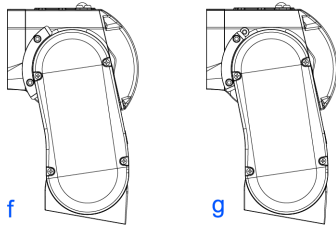

- Hexagon socket head cap bolt: M6 × 15 × 2 bolts
- Strength: Compliant with ISO 898-1 property class: 10.9 or 12.9
- Tightening torque: 13.0 ± 0.6 N·m (133 ± 6 kgf·cm)

		f	g
Angle (°)		-51, +192	-61, +202
Pulse	C8-B901*** (C8L)	-1856859, +6990528	-2220949, +7354618
	C8-B1401*** (C8XL)	-3342336, +12582912	-3997696, +13238272
Variable Mechanical Stop (J3)		Applied	Applied (standard)

3.5.3 Restriction of Manipulator Operation by Joint Angle Combination

To prevent the arms of the Manipulator from interfering each other, the Manipulator operation is restricted in the specified motion range according to the angle combination of the Joint #1, #2, and #3.

The Manipulator operation is restricted and the Manipulator stops when the joint angles are within the colored areas in the following figure.

The restriction to Manipulator operation is enabled:

- During CP motion command execution
- When you attempt to execute the motion command for moving the Manipulator to a target point (or pose) in the specified motion range.

The restriction to the Manipulator operation is disabled:

- The Arms of the Manipulator momentarily go through the specified motion range during the PTP motion command execution even though the joint angles of the Arms are in the colored areas of the figures above.

C8-B901* (C8L)**

Combination of Joint #2 and #3

- -50 deg. \leq J1 \leq 50 deg.

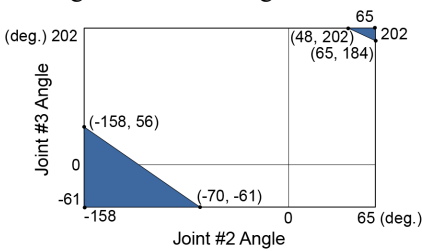

- -115 deg. \leq J1 $<$ -50 deg. or 50 deg. $<$ J1 \leq 115 deg.

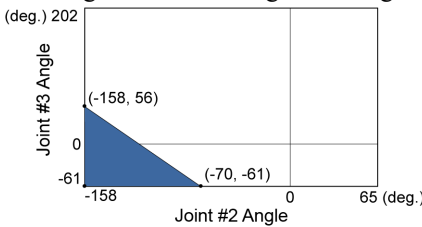

- -240 deg. \leq J1 $<$ -115 deg. or 115 deg. $<$ J1 \leq 240 deg.

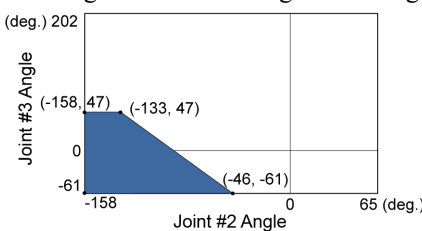

Combination of Joint #1 and #2

- -240 deg. \leq J1 \leq -110 deg. or 110 deg. \leq J1 \leq 240 deg.

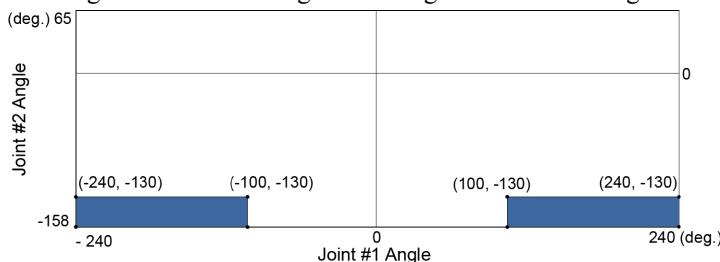

(deg.=°)

C8-B1401* (C8XL)**

Combination of Joint #2 and #3

- -110 deg. <= J1 <= 110 deg.

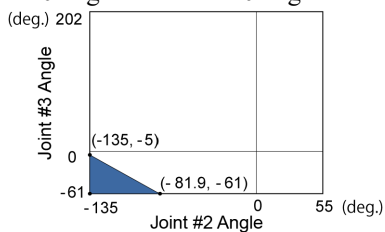

- -140 deg. < J1 < -110 deg. or 110 deg. < J1 < 140 deg.
-240 deg. < J1 < -220 deg. or 220 deg. < J1 < 240 deg.

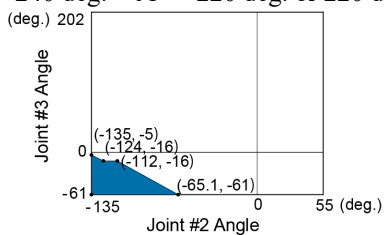

- -220 deg. <= J1 <= -140 deg. or 140 deg. < J1 < 220 deg.

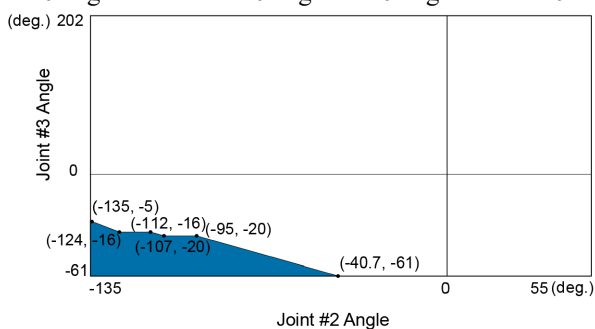

(deg.=°)

3.5.4 Coordinate System

The origin point is where the Manipulator’s installation face intersects with the rotation axis of Joint #1.

For details on the coordinate system, refer to the Epson RC+ Users Guide manual.

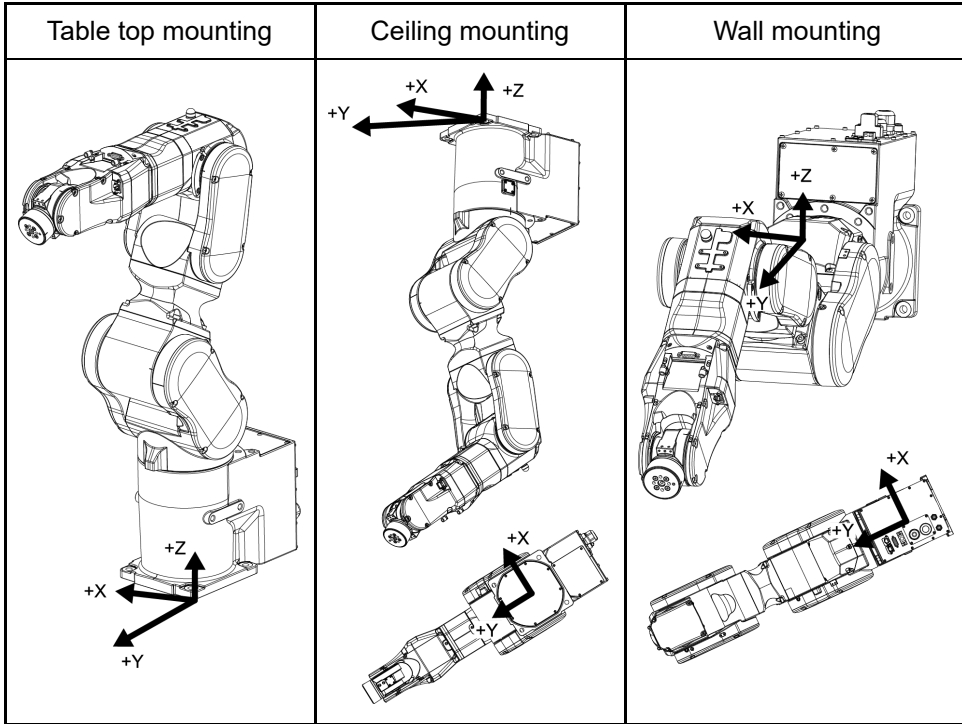

BASE setting is suitable for install the robot obliquely.

BASE setting can change a specific coordinate system of the robot and match the World coordinate system of the Jog & Teach and the coordinate system of the equipment.

For procedure of the BASE setting, refer to SPEL+ Language Reference: BASE Command.

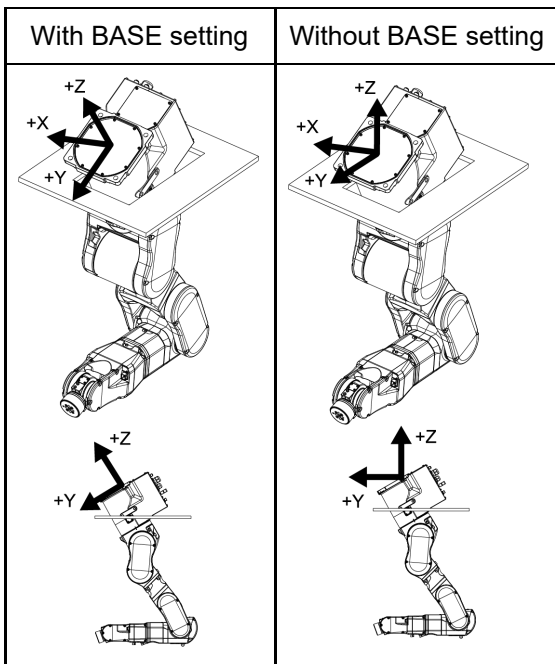

3.5.5 Changing the Robot

This section describes how to change the Manipulator model on Epson RC+.

⚠ CAUTION

Changing the Manipulator should be done with great caution. It initializes the robot calibration parameters (Hofs, CalPIs), additional axis information, and PG parameter data. Before changing the robot, make sure to save the calibration data by following the procedure below.

1. Select the Epson RC+ menu-[Setup]-[System Configuration].
2. Select [Controller]-[Robots]-[Robot**]-[Calibration] from the tree list. Then, click [Save].

1. Select the Epson RC+ menu-[Setup]-[System Configuration].
2. Select [Controller]-[Robots]-[Robot**] from the tree list. (Dialog image: Epson RC+ 8.0)

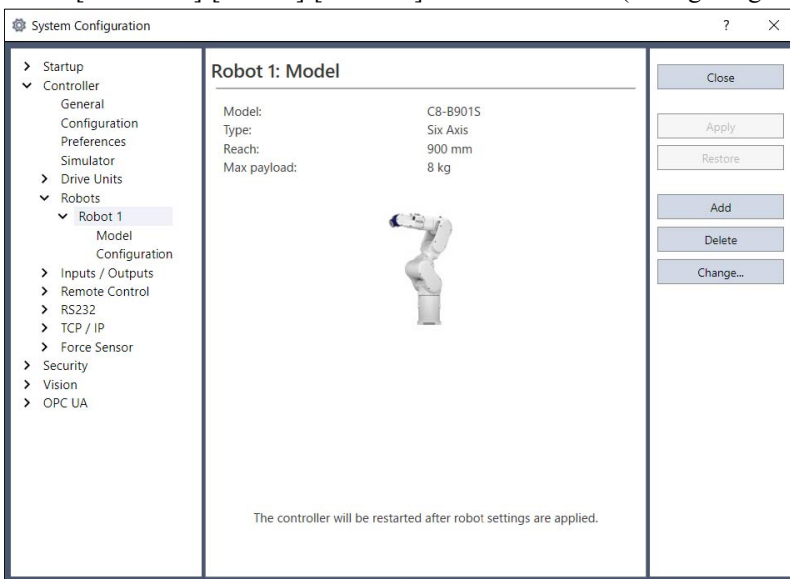

3. Click the [Change] button. The following dialog box will be displayed.

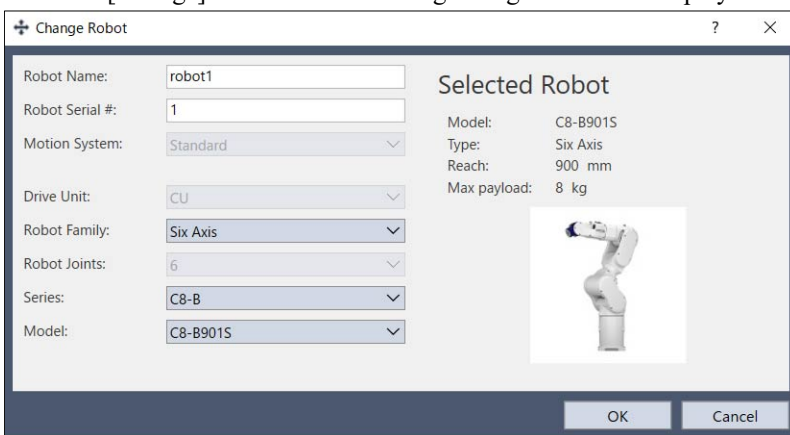

4. Input the robot name and serial number printed on the name plate of the Manipulator. Any serial number can be entered. However, enter the number printed on the Manipulator.
5. Select the robot type in the [Robot type] box.
6. Select the series name of the Manipulator in the [Series] box.
7. Select the robot model in the [Model] box.
Available robots will be displayed according to the format of the currently installed motor driver. When [Dry run] is used, all the Manipulators of the series selected in Step 6 will be displayed.

8. Click the [OK] button. The Controller is restarted.

3.5.6 Setting the Rectangular Range in the XY Coordinate System of the Manipulator

The Cartesian (rectangular) range in the XY coordinate system of the Manipulator is specified by the limited Manipulator operation area and the XYLIM setting. The limited Manipulator operation area is defined so that the hand does not interfere with the rear side of the Manipulator. The XYLIM setting that you can determine the upper and lower limits of the X and Y coordinates.

These settings are software-based limit, and so it does not change the maximum physical range. The maximum physical range is based on the position of the mechanical stops.

These settings are disabled during a joint jogging operation. Therefore, be careful not to allow the hand to collide with the Manipulator or peripheral equipment.

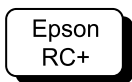

Go to [Tools] - [Robot Manager] - [XYZ Limits] panel, and make the setting. This can also be set using the XYLim statement in [Command Window].

3.6 Options

C8 series Manipulator has the following options.

- **Brake Release Unit**
- **Camera Plate Unit**
- **Tool Adapter (ISO flange)**
- **Variable Mechanical Stop**
- **User Wires and Pneumatic Tubes**

3.6.1 Brake Release Unit

While the electromagnetic brake is on (such as in emergency mode), you cannot move any arm by pushing manually. You can move the Arms by hand using the brake release unit while the Controller power is off or right after unpacking.

KEY POINTS

Precautions regarding the brake release unit

- Be sure to prepare at least one set of the brake release unit.
- Place at easy-to-reach location so that you can use it immediately when in a emergency situation.

WARNING

- Turn off the power to the Robot Controller and brake release unit when connecting or replacing the brake release unit or external short connector. Inserting or removing connectors with the power on may result in electric shock and/or malfunction of the robot system.

CAUTION

- Normally, release the brakes of joints one at a time. If the brakes of two or more joints must be released simultaneously due to unavoidable reasons, use extreme care. Releasing the brakes of multiple joints simultaneously may cause the arm to fall in an unexpected direction, resulting in hands or fingers getting caught or damage or failure of the Manipulator.
- After releasing the brake, the arm may fall by its own weight or move to the unexpected direction. Make sure to prepare a countermeasure to prevent the arm from falling and check the operation environment is safe.

Width	180 mm
Depth	150 mm
Height	87 mm
Weight (Cables are not included.)	1.7 kg
Cable to the Manipulator	2 m
M/C Short Connector	For M/C power cable short-circuit

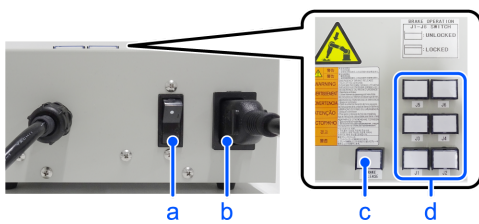

Symbol	Description
a	Power switch
b	Power Cable (You must provide.)
c	Power lamp
d	Brake release switch

3.6.1.1 Power Cable

You must provide a power cable. Be sure to use the specifications below.

Symbol	Item	Specifications
a	Plug	Comply with local safety regulation <ul style="list-style-type: none"> Class I (2P + PE), AC250 V, 6 A or 10 A Ex.: CEE Pub.7 Certified, CCC Certified, KC Certified, BS1363 Certified, PSB Certified, BIS Certified, SABS Certified Class I (2P + PE), AC125 V, 7 A, 12 A, or 15 A etc. Ex.: UL Certified, PSE Certified, BSMI Certified
b	Flexible cable	Comply with IEC/EN standards or local safety regulation Example: <ul style="list-style-type: none"> IEC 60227-1: General requirements IEC 60227-5: Polyvinyl chloride insulated cables of rated voltages up to and including 450/750 V - Part 5: Flexible cables (cords) EN 50525-1: General requirements EN 50525-2-11: Electric cables - Low voltage energy cables of rated voltages up to and including 450/750 V (Uo/U) - Part 2-11: Cables for general applications - Flexible cables with thermoplastic PVC insulation
c	Appliance coupler	Comply with IEC/EN standards or local safety regulation <ul style="list-style-type: none"> IEC / EN 60320-1: Appliance couplers for household and similar general purposes - Part 1: General requirements Standard Sheet C13: AC250 V/10 A

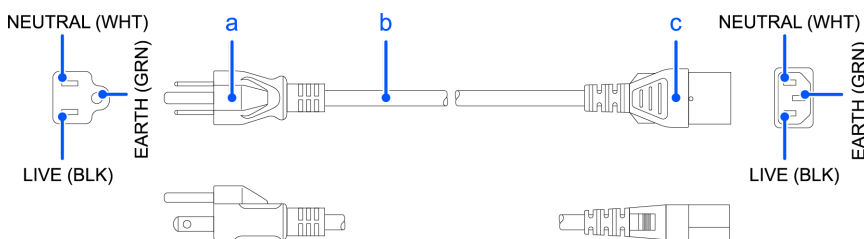

For Japan

Item	Specifications
Plug	PSE Certified Class I (2P+PE), AC125 V, 7 A or higher
Code	PSE Certified 0.75 mm ² or more
Connector	PSE Certified IEC 60320-1 Standard Sheet C13: AC125 V/10 A or higher

Precautions for use

⚠ CAUTION

- Operating the Manipulator without a brake release unit or external short connector connected may cause the brake to fail to release, possibly damaging the brake.
After using the brake release unit, be sure to connect the external short circuit connector to the Manipulator or make sure to leave the connector for the brake release unit connected.
- Keep the external short connector. Otherwise you cannot release the brakes.
- If you turn on the brake release unit while the brake release switch is being pressed, an unintended arm may move downward. Before turning on the brake release unit, make sure that the brake release switch is not pressed.
- If you turn on the brake release unit without the connector, it may lead to the short for the male pin used in the connector. Before turning on the brake release unit, make sure that the connector is connected.

3.6.1.2 Installing the Brake Release Unit

1. Turn off the Controller.
2. **If the M/C power cable is not connected to the Controller:**
Connect the M/C short connector, or connect the Controller.
(Keep the Controller power off.)
The M/C short connector can be purchased singly.



-
-
- If the M/C power cable is already connected to the Controller:**
Go to the step (3).



-
-
3. Remove the external short connector.

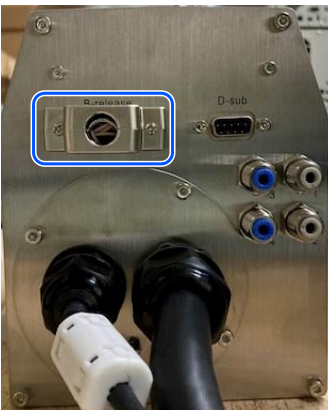

4. Connect the brake release unit to the connector of the connection cable.



3.6.1.3 Removing the Brake Release Unit

1. Turn off the brake release unit.
2. Remove the power cable of the brake release unit.
3. Disconnect the brake release unit from the connector of the connection cable.
4. If the M/C short connector is connected to the M/C power cable, remove the short connector.
5. Connect the external short connector to the connector of the connection cable.

3.6.1.4 How to Use the Brake Release Unit

⚠ CAUTION

- After releasing the brake, the arm may fall by its own weight or move to the unexpected direction. Make sure to prepare a countermeasure to prevent the arm from falling and check the operation environment is safe.
- If the arm you released its brake moves awkwardly or faster than usual, stop the operation promptly and contact the supplier. The brake release unit may be broken. If you keep operating the Manipulator, it may lead to the breakdown of the Manipulator or you may get your hand or fingers caught.

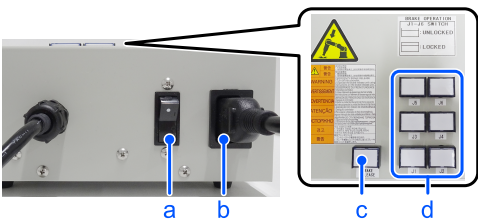

Symbol	Description
a	Power switch
b	Power cable (You must provide.)
c	Power lamp
d	Brake release switch

1. Refer to “Installing the Brake Release Unit” above to connect the brake release unit to the connector of the connection cable.
2. Plug the power cable into the brake release unit.
3. Plug the power cable into the power supply plug.

4. Turn on the brake release unit. When the brake release unit is enabled, the power lamp lights up.
5. Press the switch of the arm (J1 to J6) you want to move and then move the arm. Press the switch again. The brake will be released. The brake will be enabled by pressing the switch once again.

KEY POINTS

Move the arm the brake is released by two persons or more (one presses the switch and one moves the arm). The arm can be very heavy and needs the significant force to move.

3.6.2 Camera Plate Unit

To mount a camera to the C8 series Manipulator, you need to mount the camera plate unit first.

Appearance of arm end with camera

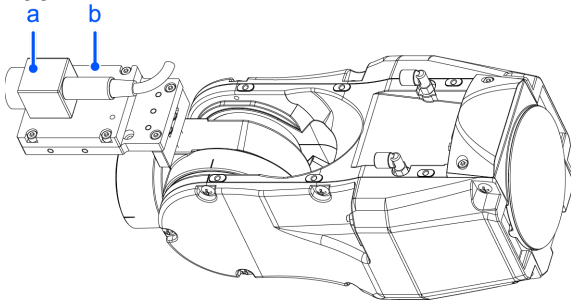

Symbol	Description
a	Camera
b	Camera Plate Unit

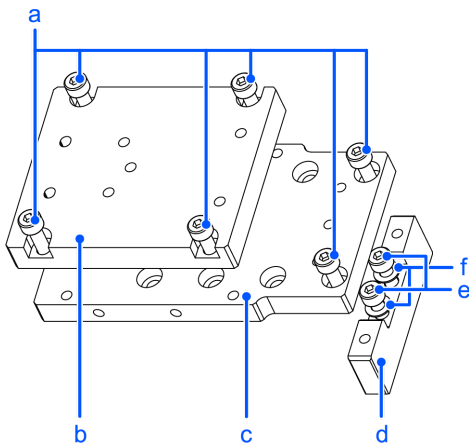

Parts Included		Qty.
a	Hexagon socket head cap bolt M4×12	6
b	Camera adapter plate	1
c	Camera mid plate	1
d	Camera base plate	1
e	Hexagon socket head cap bolt M4×20	2
f	Plain washer for M4 (small washer)	2

Installation

KEY POINTS

For details of tightening the hexagon socket head cap bolt, refer to the following section.

Tightening the Hexagon Socket Head Cap Bolts

Mounting holes for the camera base plate on the C8 series Manipulator

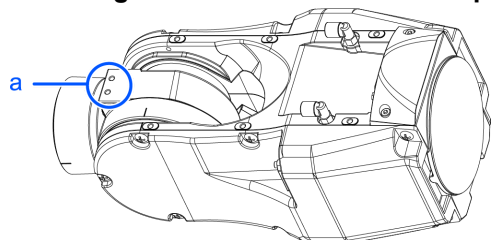

Symbol	Description
a	Mounting holes for the camera base plate

For installation procedure, refer to the following manual.
 "Epson RC+ Option Vision Guide Hardware & Setup"

Dimension of the camera plate unit

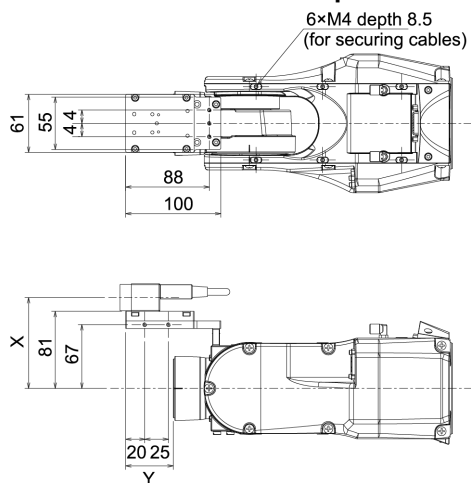

Dimensions X and Y will change depending on the position of camera mid plate and camera size. Refer to the table below for the values.

Camera mid plate

The camera mid plate uses the mounting holes A to D. By using the different mounting holes, it can be mounted to the camera base plate in the different four positions.

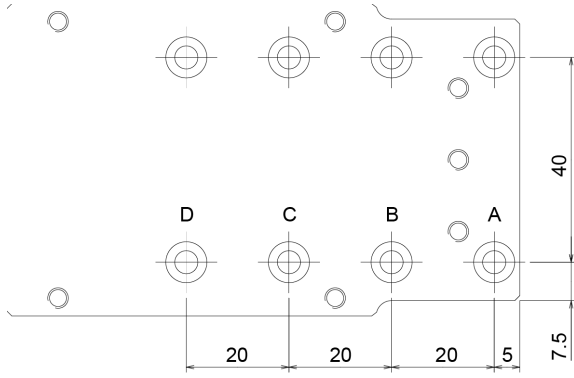

Camera and C8 series Manipulator Joint #5 motion range (reference values)

The Joint #5 motion range varies depending on the mounting position of camera mid plate and the camera you are using.

The table below shows the motion range (reference values) based on the available cameras for this option and the mounting positions of the camera mid plate. The values in the table may vary depending on how to secure the cables.

By changing the Y position, you can extend the distance from the hand mounting surface to the camera. Also, you can attach the larger hand. However, be careful about the Joint #5 motion range that will be limited in this case.

	A	B	C	D	X
USB Camera, GigE Camera	-135° to +70°	-135° to +60°	-135° to +45°	-135° to +35°	95.5 mm

	A	B	C	D
Y	50 mm	30 mm	10 mm	-10 mm

Direction of the Joint #5 motion

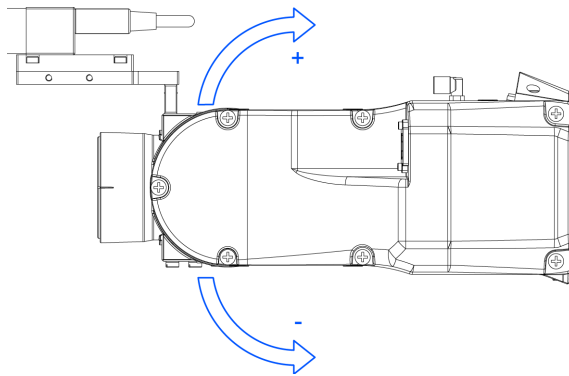

3.6.3 Tool Adapter (ISO flange)

Using the tool adapter, you can mount the hand whose dimensions are designed for the ISO flange to the C8 series Manipulators.

Parts Included	Qty.
ISO flange	1
Flange	1
Pin	2
Hexagon socket head cap bolt with low head M5×10	6

Parts Included	Qty.
Hexagon socket head cap bolt M5×15	4

Dimensions of ISO flange

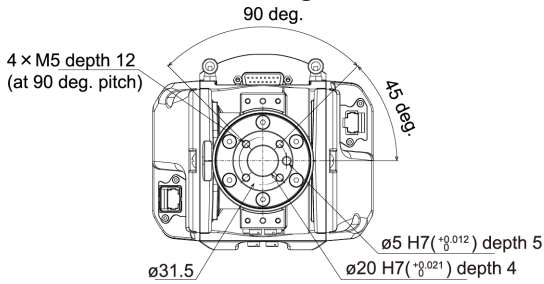

* Each dimension and tolerance complies with ISO9409-1-31.5-4-M5.

ISO flange installation

KEY POINTS

For details of tightening the hexagon socket head cap bolt, refer to the following section.

Tightening the Hexagon Socket Head Cap Bolts

1. Press-fit the pin to the Arm #6 end flange.
 Pin protrusion: 4 mm from the flange

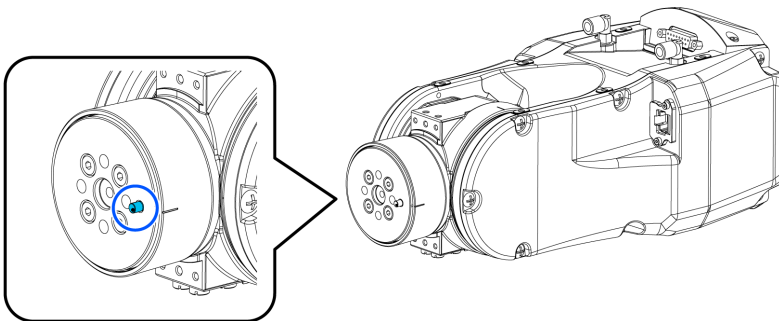

2. Align the pin and the pin hole on the flange, and then mount the flange.
 Hexagon socket head cap bolt: 4×M5×15

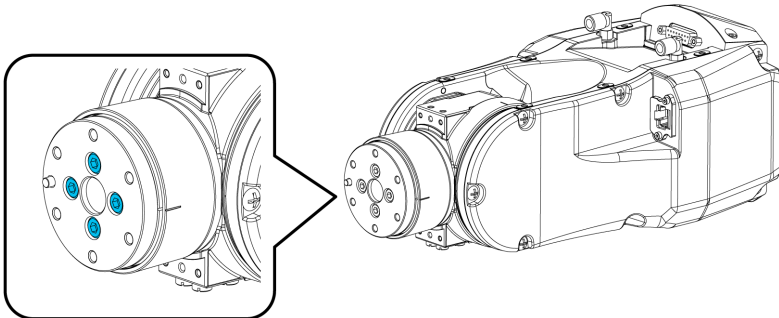

3. Press-fit the pin to the installed flange.

Pin protrusion: 4 mm from the flange

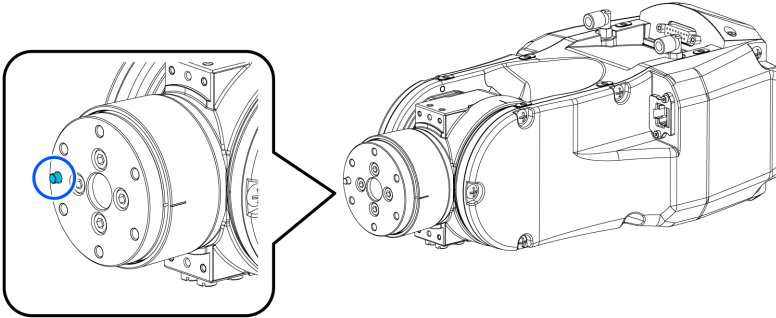

4. Align the pin and the pin hole on the ISO flange, and then mount the ISO flange.

Hexagon socket head cap bolt with low head: 6×M5×10

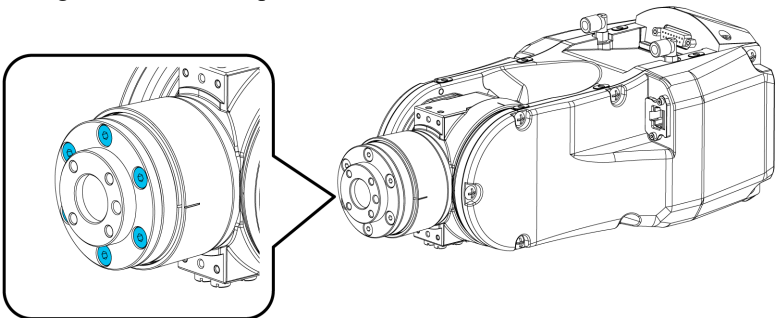

3.6.4 Variable Mechanical Stop

This option is used to mechanically limit the motion range of the Manipulator.

For installation and angle restriction measures, refer to the following section.

Setting the Work Envelope by Mechanical Stops

Variable Mechanical Stop (J1)

Parts Included	Qty.
Variable Mechanical Stop (J1)	1
Hexagon socket head cap bolt M12×30	2

Variable mechanical stop (C8L_J2)

Parts Included	Qty.
Variable mechanical stop (C8L_J2)	1
Hexagon socket head cap bolt M10×35	1

Variable mechanical stop (C8XL_J2)

Parts Included	Qty.
Variable mechanical stop (C8XL_J2)	1

Variable Mechanical Stop (J3)

Parts Included	Qty.
Variable Mechanical Stop (J3)	1

3.6.5 User Wires and Pneumatic Tubes

Use the following options when using the internal wiring and tubing for the hand drive.

Fitting for Customer Use (ø6 Straight)

Parts Included	Qty.	Manufacturer	Type
ø6 straight fitting	2	SMC	KQ2S06-M6N

* Attached as standard. The parts can be purchased additionally in case of lost or shortage.

Fitting for Customer Use (ø6 Elbow)

Parts Included	Qty.	Manufacturer	Type
ø6 elbow fitting	2	SMC	KQ2L06-M6N

* Attached as standard. The parts can be purchased additionally in case of lost or shortage.

Standard User Connector Kit (D-sub)

Parts Included	Qty.	Manufacturer	Type
Connector	2	JAE	DA-15PF-N (Solder type)
Clamp hood	2	HRS	HDA-CTH (4-40) (10) (Connector setscrew: #4-40 UNC)

* Attached to standard and cleanroom-model Manipulators as standard. The parts can be purchased additionally in case of lost or shortage.

Waterproof User Connector Kit (D-sub)

Parts Included	Qty.	Manufacturer	Type
Connector	2	HARTING	09 67 015 5615 (Solder type)
Clamp hood	2	HARTING	09 67 015 0538 (Connector setscrew: #4-40 UNC)

* Attached to the protected-model Manipulators as standard. The parts can be purchased additionally in case of lost or shortage.

Waterproof User Connector Kit (Ethernet)

Parts Included	Qty.	Manufacturer	Type
Connector	2	HARTING	09 45 145 1560

* Not attached as standard. Please purchase the item if needed. Please note that the protection rating IP67 cannot be satisfied if other connectors are used.

4. C12 Manipulator

This chapter contains information for setup and operation of the Manipulators.

Please read this chapter thoroughly before setting up and operating the Manipulators.

4.1 Safety

The Manipulator and its related equipment should be unpacked and transported by people who have received installation training provided by Epson and the suppliers. Also, the laws and regulations of the installation country must be followed.

Before use, please read this manual and other related manuals to ensure correct use. After reading this manual, store it in an easily accessible location for future reference.

This product is intended for transporting and assembling parts in a safely isolated area.

4.1.1 Conventions Used in This Manual

The following symbols are used in this manual to indicate important safety information. Be sure to read the descriptions shown with each symbol.

WARNING

This symbol indicates an imminently hazardous situation which, if operation is not performed properly, will result in death or serious injury.

WARNING

This symbol indicates a potentially hazardous situation which, if operation is not performed properly, could result in an injury due to electric shock.

CAUTION

This symbol indicates a potentially hazardous situation which, if operation is not performed properly, may result in a minor or moderate injury or in property damage only.

4.1.2 Design and Installation Safety

The robot system should be designed and installed by people who have received installation training provided by Epson and the suppliers.

Design personnel should refer to the following manuals:

- "Safety Manual"
- "Controller Manual"
- "Manipulator Manual"

Refer to the following section for the installation safety information.

[Environment and Installation](#)

Be sure to read this section and follow the safety information before installation to ensure that the installation work is performed safely.

4.1.3 Operation Safety

The following items are safety precautions for operating personnel:

WARNING

- Be sure to read the Safety Manual before use. Operating the robot system without understanding the safety information can be extremely dangerous and may result in serious injury or severe equipment damage.
- Before operating the robot system, make sure that no one is inside the safety barriers. The robot system can be operated in the teaching operation mode even when someone is inside the safety barriers. Even though the motion of the Manipulator is always restricted (low speed and low power) to ensure operator safety, an unexpected movement by the Manipulator can be extremely dangerous and may cause serious safety problems.
- If the Manipulator moves abnormally during operation of the robot system, immediately press the emergency stop switch.

WARNING

- To perform the power supply lockout, remove the power plug. Be sure to connect the AC power cable to a power outlet. Do not connect it directly to a factory power source.
- Before performing any replacement work, inform others in the area that you are working, and then turn off the Controller and related equipment, and unplug the power cable from the power source. Performing any work procedure with the power turned on is extremely dangerous and may result in electric shock and/or malfunction of the robot system.
- Do not connect or disconnect the connector of the M/C cable while the Controller is turned on. There is a risk the Manipulator may malfunction, which is extremely hazardous. Also, performing any work procedure with the power turned on may result in electric shock and/or malfunction of the robot system.

CAUTION

- Whenever possible, only one person should operate the robot system. If it is necessary to operate with more than one person, ensure that all personnel communicate with each other and take all necessary safety precautions.
- If the Manipulator is operated repeatedly with each joint having an operating angle of 5° or less, the bearings used in the joints are likely to cause oil film shortage. Repeated operation may cause premature damage. To prevent premature damage, operate the Manipulator to move each joint to an angle of 30° or more about once per hour.
- When the robot is operating at low speed (Speed: 5 to 20%), vibration (resonance) may occur continuously during operation depending on the combination of the arm orientation and hand load. Vibration occurs due to the natural vibration frequency of the arm and can be reduced by taking the following measures:
 - Changing the robot speed
 - Changing the teach points
 - Changing the hand load

4.1.4 Emergency Stop

Each robot system needs equipment that will allow the operator to immediately stop the system's operation. Install an emergency stop device by using emergency stop input from the Controller or other equipment.

Before using the emergency stop switch, be aware of the following points.

- The emergency stop switch should be used to stop the Manipulator only in case of emergencies.
- Besides pressing the emergency stop switch when an emergency occurs, to stop the Manipulator during program operation, use the Pause or STOP (program stop) statements assigned to a standard I/O.
The Pause and STOP statements do not turn off motor energization, and so the brake is not locked.

To place the robot system in emergency stop mode in a non-emergency (normal) situation, press the emergency stop switch while the Manipulator is not operating.

Do not press the emergency stop switch unnecessarily while the Manipulator is operating normally.

It could shorten the lifespan of the following components.

- Brakes
The brakes will be locked, which will shorten the lifespan of the brakes due to worn brake friction plates.
 - Normal brake lifespan:
About 2 years (when the brakes are used 100 times/day)
or about 20,000 times
- Reduction gears
An emergency stop applies an impact to the reduction gear, which can shorten its life.

If the Manipulator is stopped by turning off the Controller while it is operating, the following problems may occur.

- Reduced life and damage to reduction gear
- Position shift at the joints

If a power outage or other unavoidable Controller power-off occurs during Manipulator operation, check the following points after power is restored.

- Damage in reduction gear
- Shifting of the joints from their proper positions

If there was any shifting, maintenance is required. For more information, please contact the supplier.

Stopping distance of emergency stop

The Manipulator during operation cannot stop immediately after the emergency stop switch is pressed. Also, the stopping time and movement distance vary depending on the following factors.

- Hand weight, WEIGHT setting, ACCEL setting, workpiece weight, SPEED setting, movement posture, etc.

For the stopping time and movement distance of the Manipulator, refer to the following section.

[Appendix B: Stopping Time and Stopping Distance at Emergency Stop](#)

4.1.5 Safeguard (SG)

To maintain a safe working zone, safety barriers must be set up around the Manipulator, and safeguards must be installed at the entrance and exit of the safety barriers.

The term "safeguard" as used in this manual refers to a safety device with an interlock that allows entry into the safety barriers. Specifically, this includes safety door switches, safety barriers, light curtains, safety gates, safety floor mats, and so on. The safeguard is an input that informs the Robot Controller that an operator may be inside the safeguard area. You must assign at least one Safeguard (SG) in Safety Function Manager.

When the safeguard is opened, Protective Stop operates to change to the safeguard open state (display: SO).

- **Safeguard open**
Operations are prohibited. Further robot operation is not possible until either the safeguard is closed, the latched state is released, and a command is executed, or the TEACH or TEST operation mode is turned on and the enable circuit is activated.
- **Safeguard closed**
The robot can operate automatically in an unrestricted (high power) state.

WARNING

- If a third party accidentally releases the safeguard while an operator is working inside the safety barriers, this may result in a hazardous situation. To protect the operator working inside the safety barriers, implement measures to lock out or tag out the latch release switch.
- To protect operators working near the robot, be sure to connect a safeguard switch and make sure that it works properly.

Installing safety barriers

When installing safety barriers within the maximum range of the Manipulator, combine safety functions such as SLP. Carefully take into account the size of the hand and the workpieces to be held so that no interference occurs between the operating parts and the safety barriers.

Installing safeguards

Design the safeguards so that they satisfy the following requirements:

- When using a key switch type safety device, use a switch that forcibly opens the interlock contacts. Do not use switches that open their contacts using the spring force of the interlock.
- When using an interlock mechanism, do not disable the interlock mechanism.

Considering the stopping distance

During operation, the Manipulator cannot stop immediately even if the safeguard is opened. Also, the stopping time and movement distance vary depending on the following factors.

- Hand weight, WEIGHT setting, ACCEL setting, workpiece weight, SPEED setting, movement posture, etc.

For the stopping time and movement distance of the Manipulator, refer to the following section.

[Appendix C: Stopping Time and Stopping Distance When Safeguard is Open](#)

Precautions for safeguard operation

Do not open the safeguard unnecessarily while the motor is energized. Frequent safeguard inputs will reduce the life of the relay.

- Normal relay lifespan: About 20,000 times

4.1.6 How to Move Arms with the Electromagnetic Brake

There are two methods to release the electromagnetic brake. Follow either method to release the electromagnetic brake and move the arms manually.

- **When using a brake release unit**
Follow the method when you just unpack the delivered boxes or when the Controller does not start up yet.
- **When using software**
Follow the method when you can use the software.

While the electromagnetic brake is on (such as in emergency mode), you cannot move any arm by pushing manually.

Arm Motion

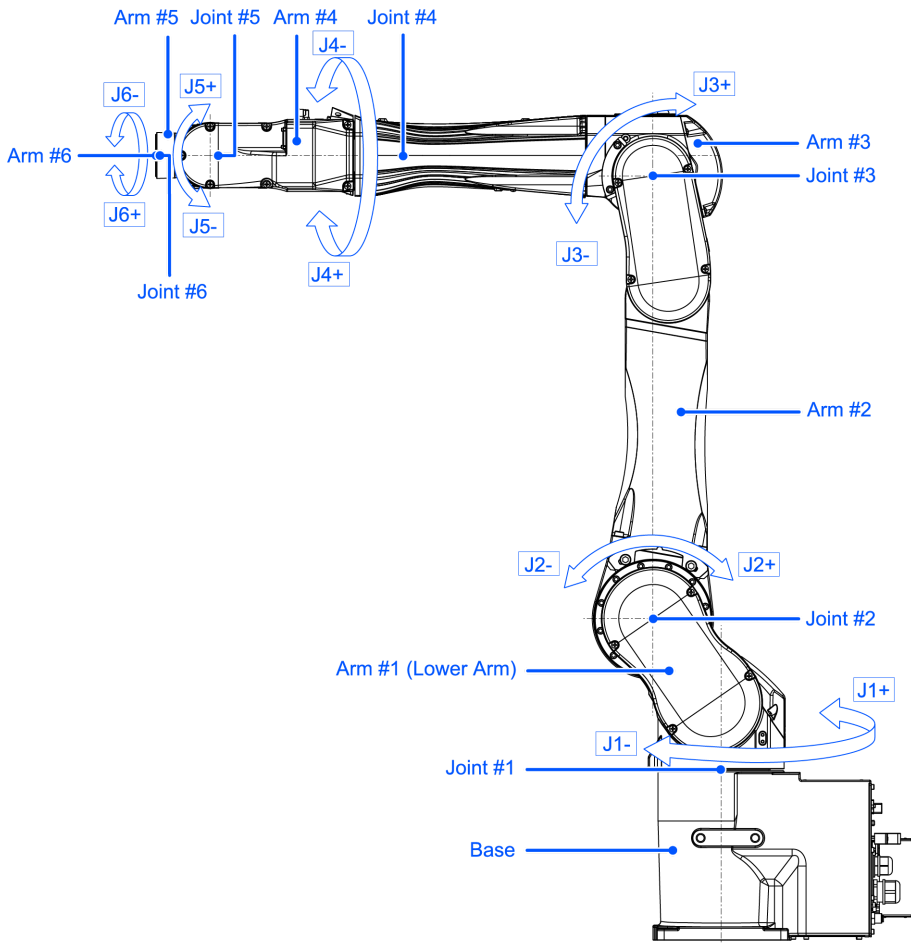

4.1.6.1 When using a brake release unit

This series has the Brake Release Unit as an option. For details, refer to the following section.

Options

4.1.6.2 When using software

⚠ CAUTION

- Normally, release the brakes of joints one at a time. If the brakes of two or more joints must be released simultaneously due to unavoidable reasons, use extreme care. Releasing the brakes of multiple joints simultaneously may cause the arm to fall in an unexpected direction, resulting in hands or fingers getting caught or damage or failure of the Manipulator.
- After releasing the brake, the arm may fall by its own weight or move to the unexpected direction. Make sure to prepare a countermeasure to prevent the arm from falling and check the operation environment is safe.
- Before releasing the brake, be sure to keep the emergency stop switch in an easily accessible location so that you can immediately press it if necessary. Otherwise, if the emergency stop switch is not easily accessible, you will be unable to immediately stop the arm falling due to an erroneous operation, which could lead to Manipulator damage or breakdown.

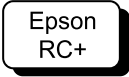

After releasing the Emergency Stop switch, execute the following command in [Command Window].

```
>Reset
>Brake Off, [The number (from 1 to 6) corresponding to the arm whose brake will be
turned off]
```

Execute the following command to turn on the brake again.

```
>Brake On, [The number (from 1 to 6) corresponding to the arm whose brake will be
turned on]
```

4.1.7 Precaution for Operation in Low Power Status

In the low power status, the Manipulator operates at low speed and low torque. However, comparatively high torque as shown in the table below may be generated to support the Manipulator’s own weight. Carefully operate the Manipulator since it may get your hands or fingers caught during operation. The Manipulator may also collide with peripheral equipment and cause equipment damage to or malfunction of the Manipulator.

Maximum Joint Torque in Low Power Status [Unit: N·m]

Joint		#1	#2	#3	#4	#5	#6
Joint Torque	C12-B1401** (C12XL)	573.06	517.66	256.9	57.45	53.44	23.94

⚠ CAUTION

- Carefully operate the Manipulator in the low power status. A comparatively high joint torque may be generated. It may cause your hands and fingers caught and/or cause equipment damage to or malfunction of the Manipulator as it may collide with peripheral equipment.

4.1.8 Warning Labels

The Manipulator has the following warning labels. Specific hazards exist in the vicinity of areas with the warning labels. Be thoroughly careful in handling. To ensure that the Manipulator is operated and maintained safely, be sure to follow the safety information and warnings indicated on the warning labels. Also, do not tear, damage, or remove these warning labels.

4.1.8.1 Warning Labels



Touching any internal electrified parts while the power is turned on may cause electric shock.

B



HOT Be careful not to burn yourself.

C



When releasing the brakes, be careful of the arm falling due to its own weight.

This warning label is attached on the Manipulator and optional brake release unit as well.

4.1.8.2 Information Labels

1

This indicates the product name, model name, serial number, information of supported laws and regulations, product specifications (Weight, MAX.REACH, MAX.PAYLOAD, AIR PRESSURE, Motor Power), Main document No., manufacturer, importer, date of manufacture, country of manufacture, and the like.

For details, see the label affixed to the product.

2



This indicates the position for mounting eyebolts. Refer to the following section for examples of using eyebolts.

[Environment and Installation](#)

Location of Labels

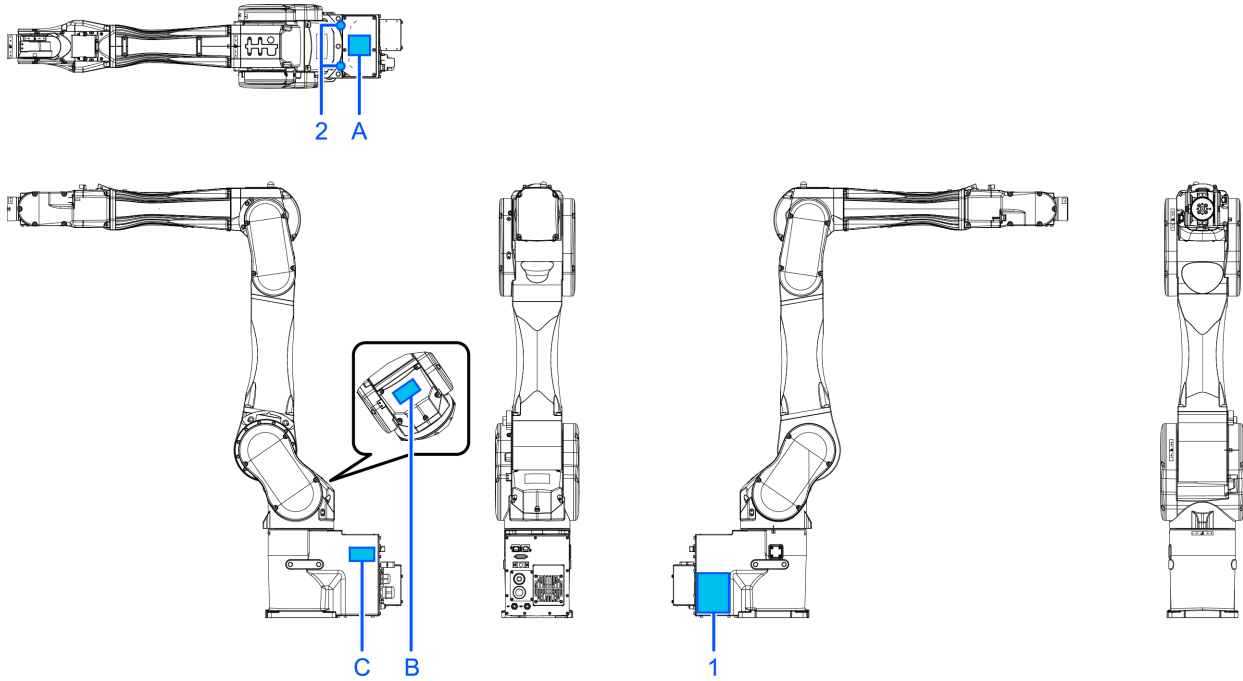

4.1.9 Responses for Emergencies or Malfunctions

4.1.9.1 When a Collision with the Manipulator Occurs

If the Manipulator has collided with a mechanical stop, peripheral device, or other object, discontinue use and contact the supplier.

4.1.9.2 Entanglement with the Manipulator

When the operator is caught between the Manipulator and a mechanical part such as a base table, press the emergency stop switch to release the brake on the subject arm, and then move the arm by hand.

How to release a brake

- When using a brake release unit, refer to the following section.
[Brake Release Unit](#)
- When using software, refer to the following section.
[When using software](#)

4.2 Specifications

4.2.1 Model Number

C12-B1401S

[a]

[b]

[c]

[d]

[e]

- a: Arm length
 - 14: 1400 mm
- b: Brake equipment
 - 1: Brakes on all joints
- c: Environment
 - S: Standard *1

- C: Cleanroom & ESD (anti-static) *1
- d: M/C cable installation direction
 - □: Cable backward
 - B: Cable downward
- e: Mounting type
 - □: Table top mounting

*1 Equivalent to IP20

4.2.2 Part Names and Motion Range of Each Arm

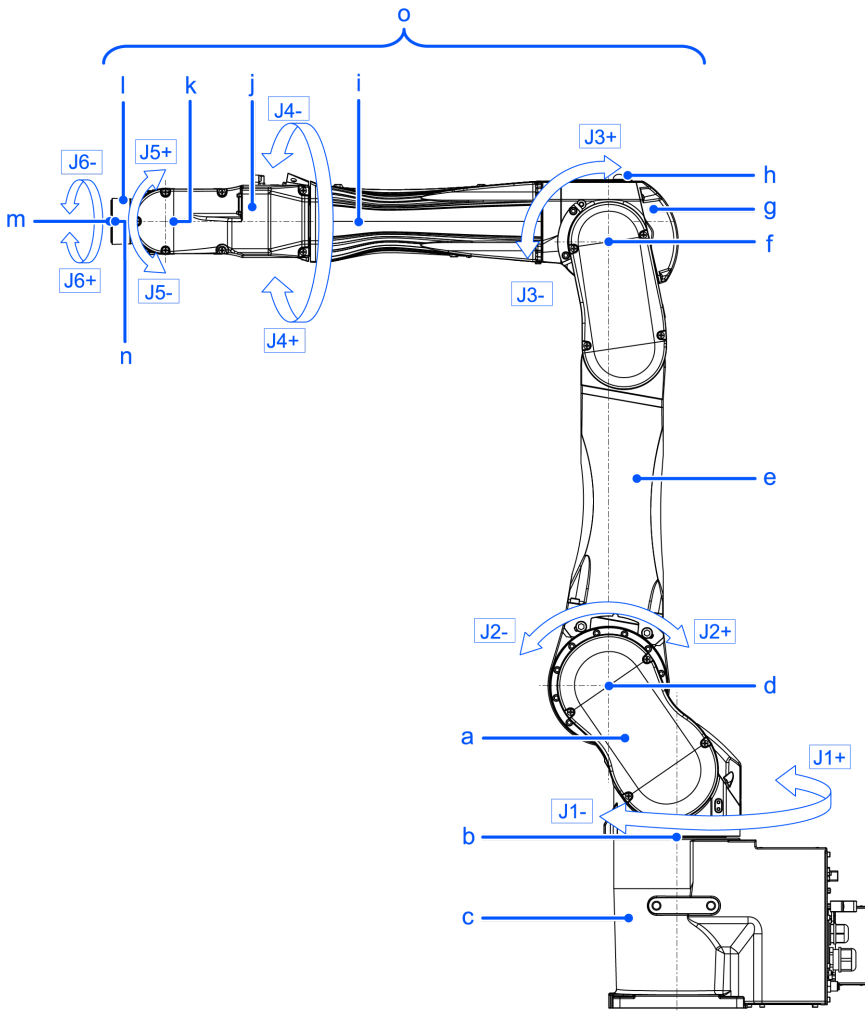

Symbol	Description
a	Arm #1 (Lower Arm)
b	Joint #1 (The whole Manipulator revolves.)
c	Base
d	Joint #2 (The lower arm swings.)
e	Arm #2
f	Joint #3 (The upper arm swings.)
g	Arm #3

Symbol	Description
h	LED Lamp (This lamp lights up while the motors are on.)
i	Joint #4 (The wrist revolves.)
j	Arm #4
k	Joint #5 (The wrist swings.)
l	Arm #5
m	Arm #6
n	Joint #6 (The hand rotates.)
o	Upper Arm (Arms #3 to #6)

 **KEY POINTS**

When the LED lamp is lighting or the Controller power is on, the current is being applied to the Manipulator. (The LED lamp may not be seen depending on the Manipulator's posture. Be thoroughly careful. Performing any work procedure with the power turned on is extremely dangerous and may result in electric shock and/or malfunction of the robot system. Before starting any maintenance work, be sure to turn off the Controller.

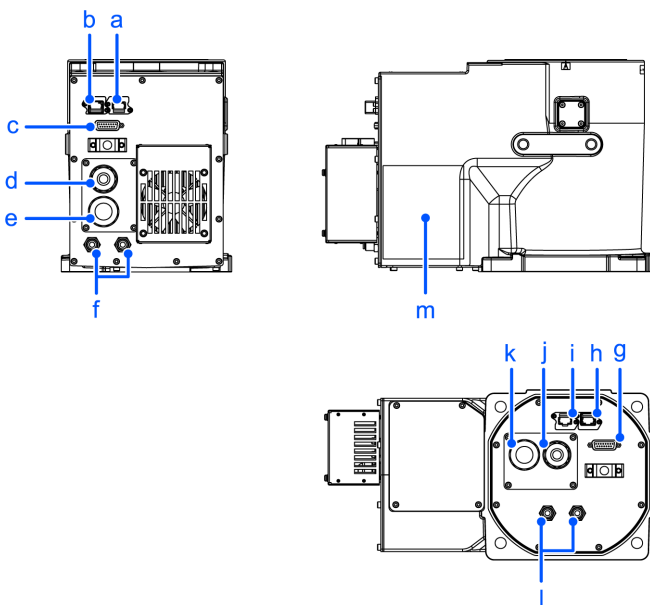

Cable backward model

Symbol	Description
a	Ethernet cable connector
b	Force Sensor cable connector
c	User cable connector (15-pin D-sub connector)
d	Signal cable
e	Power cable
f	Fitting for ø6 mm tube (Air1, Air2)

Cable downward model

Symbol	Description
g	User cable connector (15-pin D-sub connector)
h	Force Sensor cable connector
i	Ethernet cable connector
j	Signal cable
k	Power cable
l	Fitting for $\varnothing 6$ mm tube (Air1, Air2)

Cable backward model, Cable downward model

Symbol	Description
m	Face plate (serial number of Manipulator)

4.2.3 Outer Dimensions

(Units: mm)

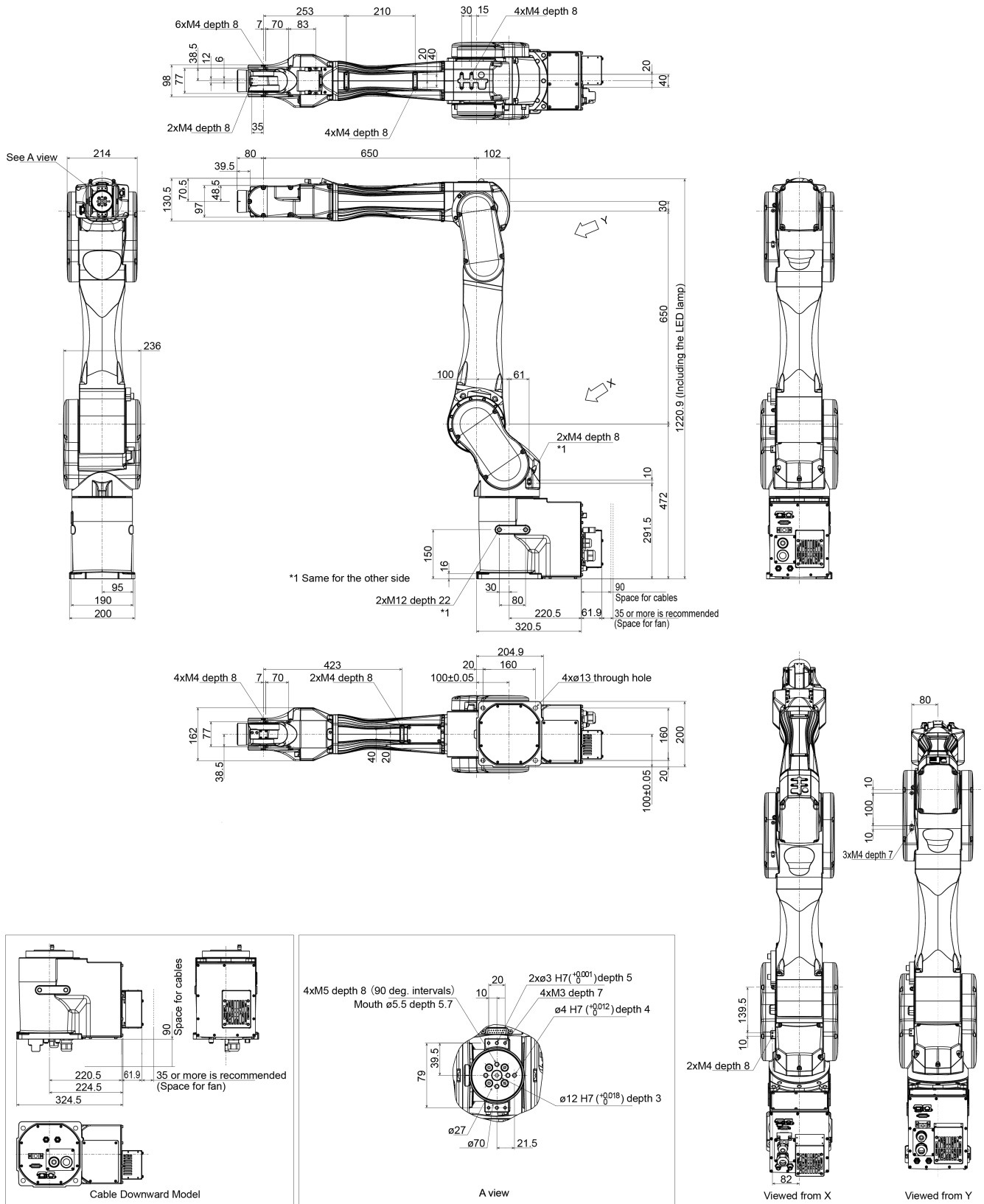

4.2.4 Standard Work Envelope

(Units: mm)

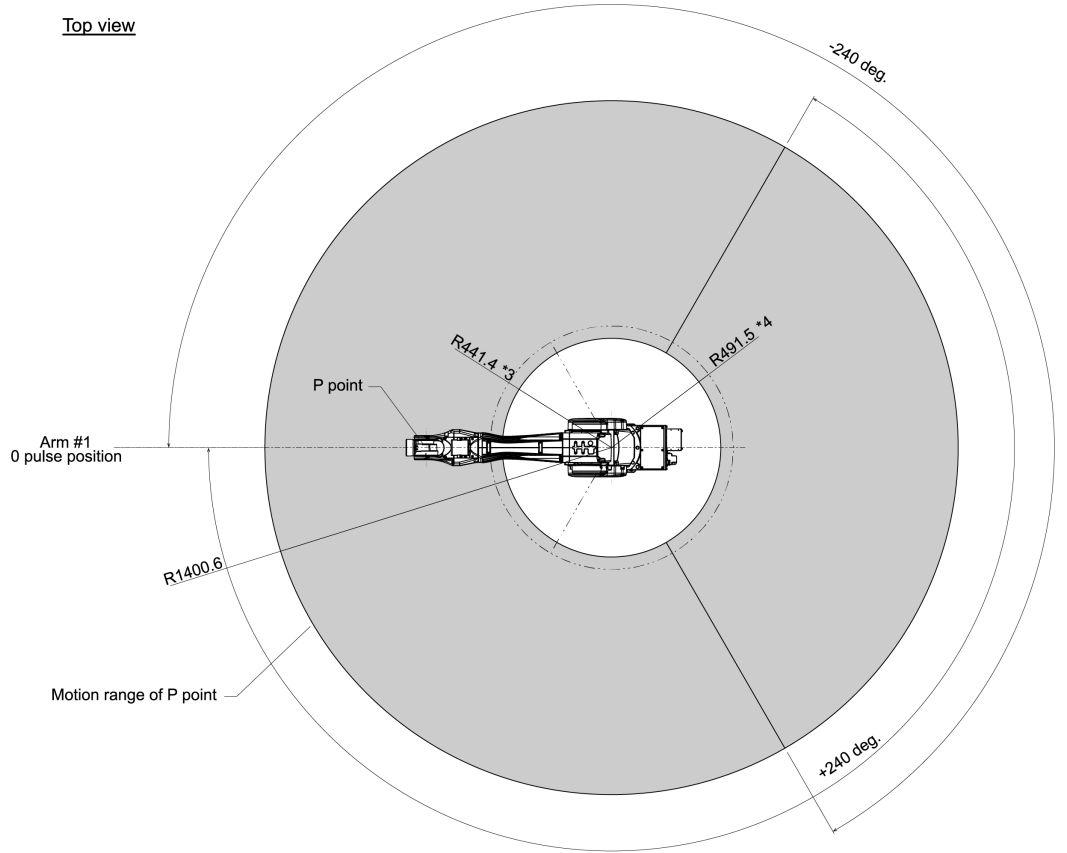

Front view

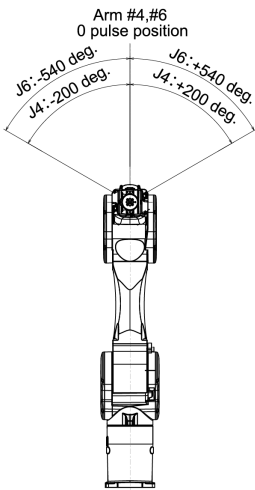

Lateral view

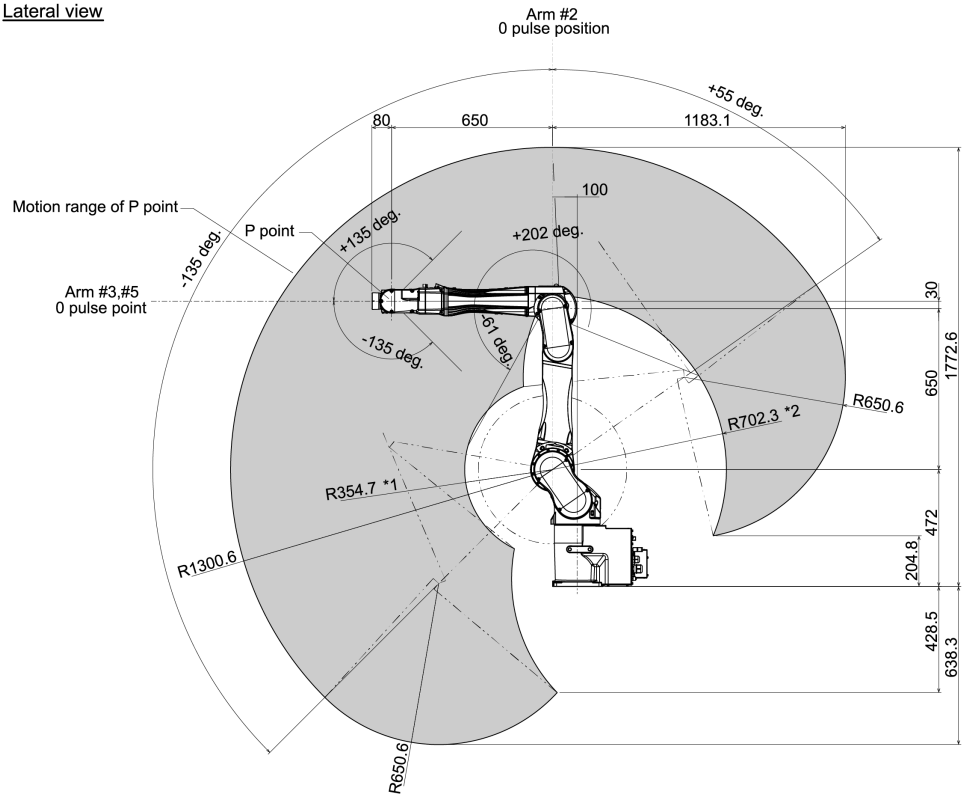

(deg. = °)

*P point: Intersection of the rotation centers for Joint #4, #5, and #6

*1: P point from lateral with Joint #3 declining -61° (Joint #2 center – P point center)

*2: P point from lateral with Joint #3 tilting up $+202^{\circ}$ (Joint #2 center – P point center)

*3: P point from top with Joint #3 declining -61° (Joint #1 center – P point center)

*4: P point from top with Joint #3 tilting up $+202^{\circ}$ (Joint #1 center – P point center)

CAUTION

- Pay attention to the arm pose of the basic arms (Arms #1, #2, and #3) when operating the Manipulator. Arm #5 moves keeping a constant angle regardless of the arm pose. Depending on the arm pose of the basic arms, the wrist may collide with the Manipulator. The collision may cause equipment damage to and/or malfunction of the Manipulator.

4.2.5 Specifications

4.2.5.1 Specifications Table

For the specifications tables of each model, refer to the following section.

[C12 Specifications](#)

4.2.5.2 Options

For details, refer to the following section.

[Options](#)

4.2.6 How to Set the Model

The Manipulator model for your system has been set before shipment from the factory.

CAUTION

- If changing the setting of the Manipulator model, be responsible and absolutely certain that the wrong Manipulator model is not set. Incorrect setting of the Manipulator model may result in abnormal or no operation by the Manipulator and could even cause safety problems.

If a custom specifications number (MT*** or X***) is written on the face plate (serial number label), the Manipulator has custom specifications.

Models with custom specifications may require a different setting procedure. Check the custom specifications number, and contact the supplier for more information.

The Manipulator model is set from software. For details, refer to the following manual.

"Epson RC+ User's Guide - Robot Configuration"

4.3 Environment and Installation

The robot system should be designed and installed by people who have received installation training provided by Epson and the suppliers. Also, the laws and regulations of the installation country must be followed.

4.3.1 Environment

To ensure that the robot system operates and maintains maximum performance and to ensure its safe use, the robot system should be installed in an environment that meets the following requirements.

Item	Conditions
Ambient temperature *	Installation: 5 to 40°C Transport, storage: -20 to 60°C
Ambient relative humidity	Installation: 10 to 80% (no condensation) Transport, storage: 10 to 90% (no condensation)
Fast transient burst noise	1 kV or less (signal line)
Electrostatic noise	4 kV or less
Altitude	1000 m or less
Environment	<ul style="list-style-type: none"> ▪ Install indoors. ▪ Keep away from direct sunlight. ▪ Keep away from dust, oily smoke, salinity, metal powder, and other contaminants. ▪ Keep away from flammable or corrosive liquids and gases. ▪ Keep away from water. ▪ Keep away from shocks or vibrations. ▪ Keep away from sources of electric noise. ▪ Keep away from explosive areas. ▪ Keep away from large quantities of radiation.

* The ambient temperature requirement is for the Manipulator only. For details on the environment requirements for the connected Controller, refer to the Robot Controller manual.

When used in a low-temperature environment near the minimum temperature specified in the product specifications, or when the unit is idle for a long period of time during holidays or at night, a collision detection error or similar error may occur immediately after the start of operation due to high resistance in the drive unit. In such cases, warm-up operation for about 10 minutes is recommended.

 **KEY POINTS**

If the Manipulator will be used in a location that does not meet the above requirements, please contact the supplier.

 **KEY POINTS**

When used in a low-temperature environment near the minimum temperature specified in the product specifications, or when the unit is idle for a long period of time during holidays or at night, a collision detection error or similar error may occur immediately after the start of operation due to high resistance in the drive unit. In such cases, warm-up operation for about 10 minutes is recommended.

KEY POINTS

If there are conductive objects such as fences or ladders within 2.5 m of the Manipulator, these objects must be grounded.

WARNING

- Always use a circuit breaker for the Controller's power supply. Failure to use a circuit breaker may result in an electrical shock hazard or malfunction due to an electrical leakage. Select the correct circuit breaker based on the Controller that you are using. For details, refer to the following manual.

"Robot Controller Manual"

CAUTION

- When cleaning the Manipulator, do not rub it strongly with alcohol or benzene. Coated surfaces may lose their luster.

4.3.2 Manipulator Mounting Dimensions

Mounting Area

Also, besides the area required for installation of the Manipulator, Controller, peripheral equipment, and other devices, the following space should be provided at a minimum.

- Space for teaching
- Space for maintenance and inspections (for installing jigs and working safely within the safety barriers)
- Space for cables

KEY POINTS

- When installing the cables, be sure to maintain sufficient distance from obstacles.
- For the minimum bend radius of the M/C cable, refer to the following section.

[C12 Specifications](#)

- Also, leave enough space for other cables so that they are not forced to bend at extreme angles.

KEY POINTS

Make sure to leave 35 mm or more space around the fan cover.

4.3.2.1 Cable backward model

(Units: mm)

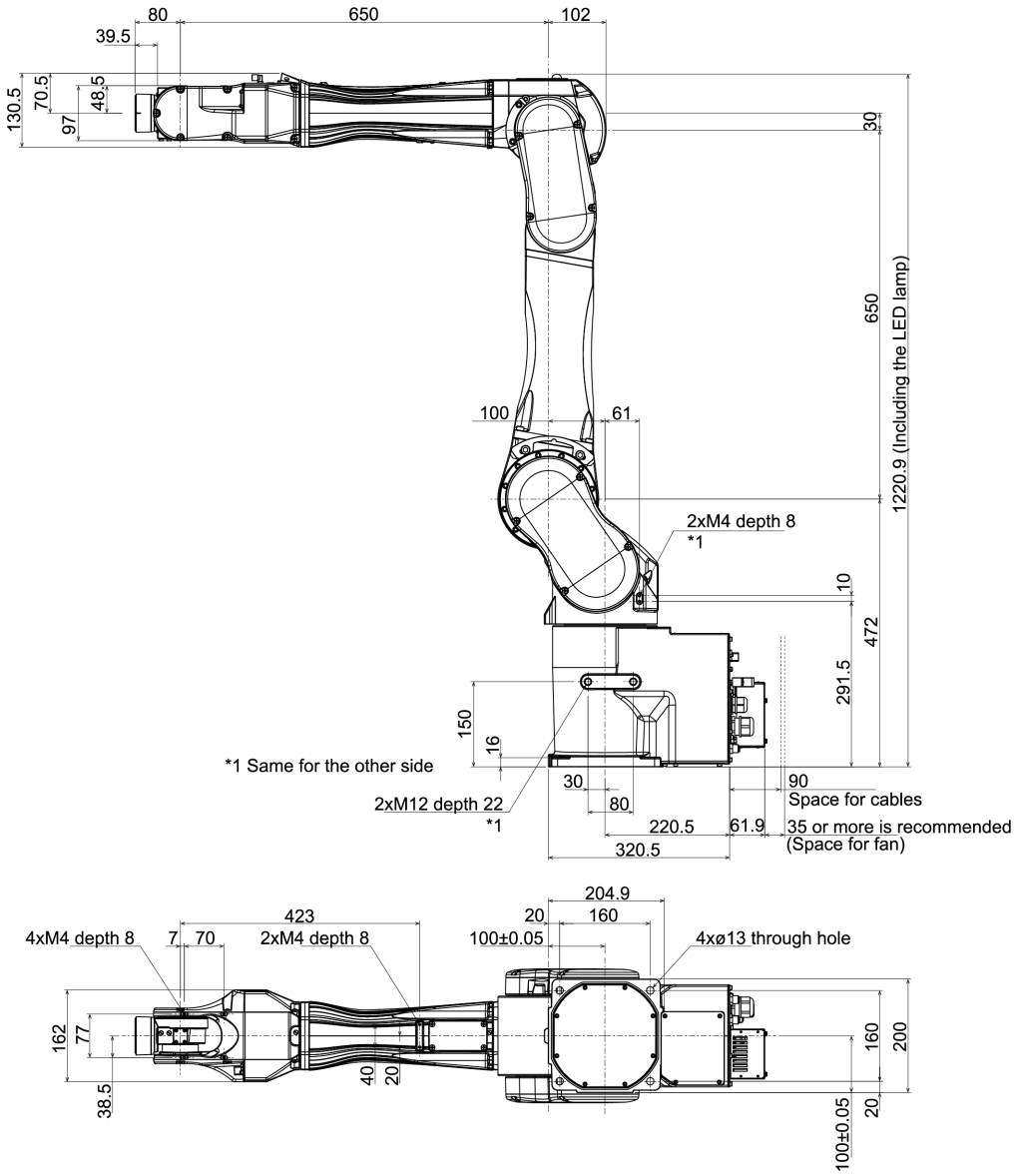

depth = depth of threaded hole

4.3.2.2 Cable downward model

The following part differs from the cable backward model.

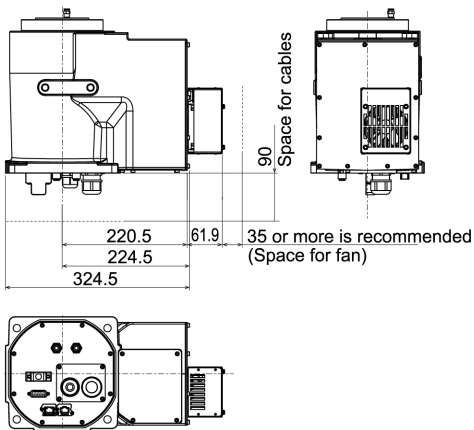

4.3.3 From Unpacking to Installation

Transportation and installation of the Manipulator and related equipment should be performed by people who have received installation training provided by Epson and the suppliers. Also, the laws and regulations of the installation country must be followed.

⚠ WARNING

- Only qualified personnel should perform sling work and operate a crane or a forklift. When these operations are performed by unqualified personnel, it is extremely hazardous and may result in serious bodily injury and/or severe equipment damage to the robot system
- When hoisting the Manipulator, use your hands to balance it. Losing balance may cause the Manipulator to drop, which is extremely hazardous and may result in serious injury and/or severe damage to the robot system.
- To ensure safety, be sure to install safeguards for the robot system. For more information on safeguards, refer to the following manual.
"Epson RC+ User's Guide - Safety - Installation and Design Precautions "
- Install the Manipulator in a location with sufficient space so that a tool or a work piece does not touch a wall or a safeguard when the Manipulator extends its arm fully while holding a work piece. If the tool or the workpiece tip reaches a wall or safeguards, it is extremely hazardous and may result in serious bodily injury and/or severe equipment damage to the robot system.
- Be sure to anchor the Manipulator before turning on the power or operating it. Turning on the power or operating the Manipulator while it is not anchored may cause the Manipulator to fall over, which is extremely hazardous and may result in serious injury and/or severe damage to the robot system.
- Before installing or operating the Manipulator, make sure that no parts of the Manipulator are missing and that it has no damage or other external defects. Missing parts or damage may cause malfunction of the Manipulator, is extremely hazardous, and may result in serious injury and/or severe equipment damage to the robot system.

⚠ CAUTION

- Use a cart or the like to transport the Manipulator in the same status as it was delivered.
- When removing the fixing bolts securing the Manipulator to the transportation pallet and the packing box or the anchor bolts, support the Manipulator to prevent it falling. Removing the fixing bolts or anchor bolts without supporting the Manipulator may cause it to fall, catching your hands or feet.
- The Manipulator should be transported by two or more people or secured to transporting equipment. Also, do not hold the bottom of the base (the screened parts in the figure). Holding these parts by hand is extremely hazardous and may cause your hands and fingers caught.

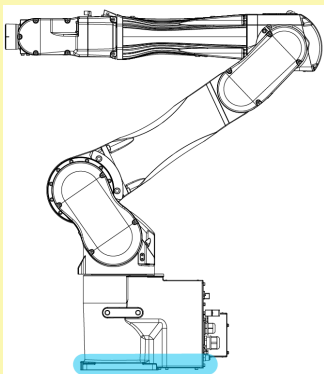

Manipulator weight: 63 kg: 139 lb

- Take extra care when transporting the Manipulator. You may hit and damage the connector.



- During unpacking and relocation, avoid applying external force to the arms and motors of the Manipulator.
- When transporting the Manipulator over long distances, secure it directly to transporting equipment so that it will not fall. If necessary, pack the Manipulator using the same packaging as delivery.
- The Manipulator must be installed to avoid interference with surrounding buildings, structures, and other machines and equipment that may create a trapping hazard or pinch points.
- Resonance (resonating sound or minute vibrations) may occur during Manipulator operation depending on the rigidity of the base table. If the resonance occurs, improve the rigidity of the base table or change the speed or acceleration and deceleration settings of the Manipulator.
- Manipulator base has a cooling fan. Install the Manipulator not to seal the cooling fan. For details, refer to the following figure.
 - [Cable backward model](#)
 - [Cable downward model](#)

Protective tape

Remove the protective tape (4 places).

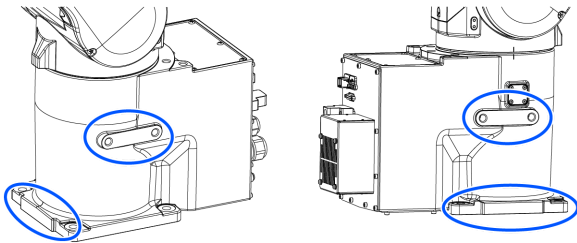

Fixing bolt

For details on the dimensions, refer to the following sections.

Manipulator Mounting Dimensions

There are four threaded holes for the Manipulator base. Use M12 mounting bolts conforming to the strength equivalent to ISO898-1 property class 10.9 or 12.9. Tightening torque: 100.0 ± 5.0 N·m (1,020 ± 51 kgf·cm)

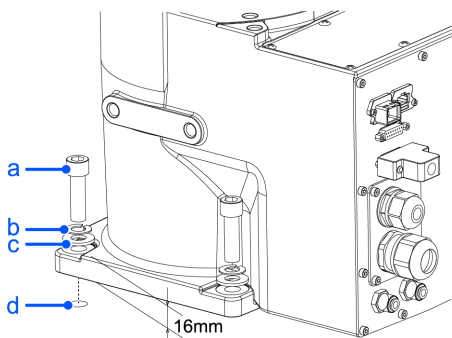

Symbol	Description
a	4×M12×40
b	Spring washer
c	Plain washer
d	Threaded hole (25 mm or more depth)

Base table

A base table for anchoring the Manipulator is not supplied. The base table must be fabricated or obtained by the customer.

The shape and size of the base table vary depending on the application of the robot system. As a reference when designing the base table, the requirements from the Manipulator side are shown here.

The base table must not only be able to bear the weight of the Manipulator but also be able to withstand the dynamic movement of the Manipulator when it operates at maximum acceleration/deceleration. Ensure that there is enough strength on the base table by attaching reinforcing materials such as crossbeams.

Followings are the torque and reaction force produced by the movement of the Manipulator.

Maximum rotating torque on horizontal surface (N·m)	2600
Maximum reaction force in horizontal direction (N)	1000
Maximum rotating torque on vertical surface (N·m)	3400
Maximum reaction force in vertical direction (N)	7900

The plate for the Manipulator mounting face should be at least 30 mm thick and made of steel for reducing vibrations.

A surface roughness of 25 µm or less at the maximum height is appropriate.

The base table must be secured on the floor to prevent it from moving.

The Manipulator installation surface should have a flatness of 0.5 mm or less and an inclination of 0.5° or less. If the installation surface does not have the proper flatness, the base of the Manipulator may be damaged or the robot may be unable to operate at maximum performance.

When using a leveler to adjust the height of the base table, use a screw with M16 diameter or more.

Connector

If passing cables through the holes in the base table, refer to the connector dimensions in the figures below. (Units: mm)

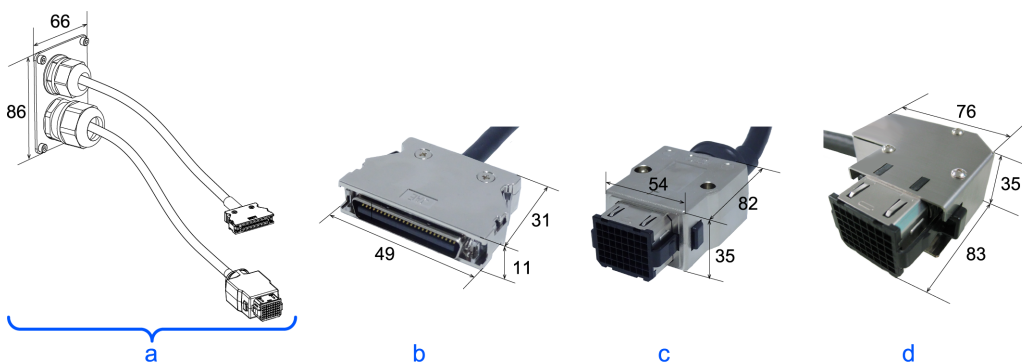

Symbol	Description
a	M/C cable

Symbol	Description
b	Signal cable connector
c	Power cable connector (straight)
d	Power cable connector (L-shaped)

Do not remove the M/C cables from the Manipulator.

KEY POINTS

For details on the environmental requirements for the space when housing the Controller in the base table, refer to the Robot Controller manual.

When using the Manipulator in the clean room, follow the steps below before the installation.

1. Unpack the Manipulator outside of the cleanroom.
2. Secure the Manipulator to transporting equipment (or a pallet) with bolts so that the Manipulator does not fall down.
3. Wipe off any dust on the Manipulator using a lint-free cloth that was dipped in ethyl alcohol or distilled water.
4. Carry the Manipulator into the cleanroom.
5. Secure the Manipulator to the base table.

4.3.4 Connecting the Cables

WARNING

- Before performing any replacement work, turn off the Controller and related equipment, and unplug the power cable from the power source. Performing any work procedure with the power turned on is extremely dangerous and may result in electric shock and/or malfunction of the robot system.
- Be sure to connect the AC power cable to a power outlet. Do not connect it directly to a factory power source. To perform the power supply lockout, remove the power plug. Working while connecting the AC power cable to a factory power source may result in electric shock and/or malfunction of the robot system.
- Be sure to connect the cables properly. Do not put heavy objects on the cables, bend or pull on the cables forcibly, or allow the cables to be pinched. Damaged cables, broken wires, or contact failure is extremely hazardous and may result in electric shock and/or malfunction of the robot system.
- Be sure to turn off the power and tag out (e.g., with a "DO NOT TURN ON" sign) before performing wiring. Performing any work procedure with the power turned on is extremely dangerous and may result in electric shock and/or malfunction of the robot system.
- The Manipulator is grounded by connecting it to the Controller. Ensure that the Controller is grounded and the cables are correctly connected. If the ground wire is improperly connected to ground, it may result in the fire or electric shock.
- Turn off the power to the Robot Controller and brake release unit when connecting or replacing the brake release unit or external short connector. Inserting or removing connectors with the power on may result in electric shock and/or malfunction of the robot system.

CAUTION

- When connecting the Manipulator and the Controller, check that the serial numbers match for each device. Improper connection between the Manipulator and the Controller may not only lead to malfunction of the robot system but also safety problems. The connection method between the Manipulator and the Controller varies depending on the Controller. For details on the connection, refer to the following manual.

"Robot Controller Manual"

- Only authorized or certified personnel should perform wiring. Wiring by unauthorized or uncertified staff may result in bodily injury and/or malfunction of the robot system.
- Operating the Manipulator without a brake release unit or external short connector connected may cause the brake to fail to release, possibly damaging the brake.

After using the brake release unit, be sure to connect the external short circuit connector to the Manipulator or make sure to leave the connector for the brake release unit connected.

Cleanroom-model Manipulator

When the Manipulator is a model with cleanroom specifications, an exhaust system must be connected. For the exhaust system, refer to the following section.

C12 Specifications

Connection procedure for M/C cable

Connect the power connector and signal connector of the M/C cable to the Controller.

4.3.5 User Wires and Pneumatic Tubes

⚠ CAUTION

- Only authorized or certified personnel should perform wiring. Wiring by unauthorized or uncertified staff may result in bodily injury and/or malfunction of the robot system.

User electrical wires and pneumatic tubes are contained in the cable unit.

Cable backward model

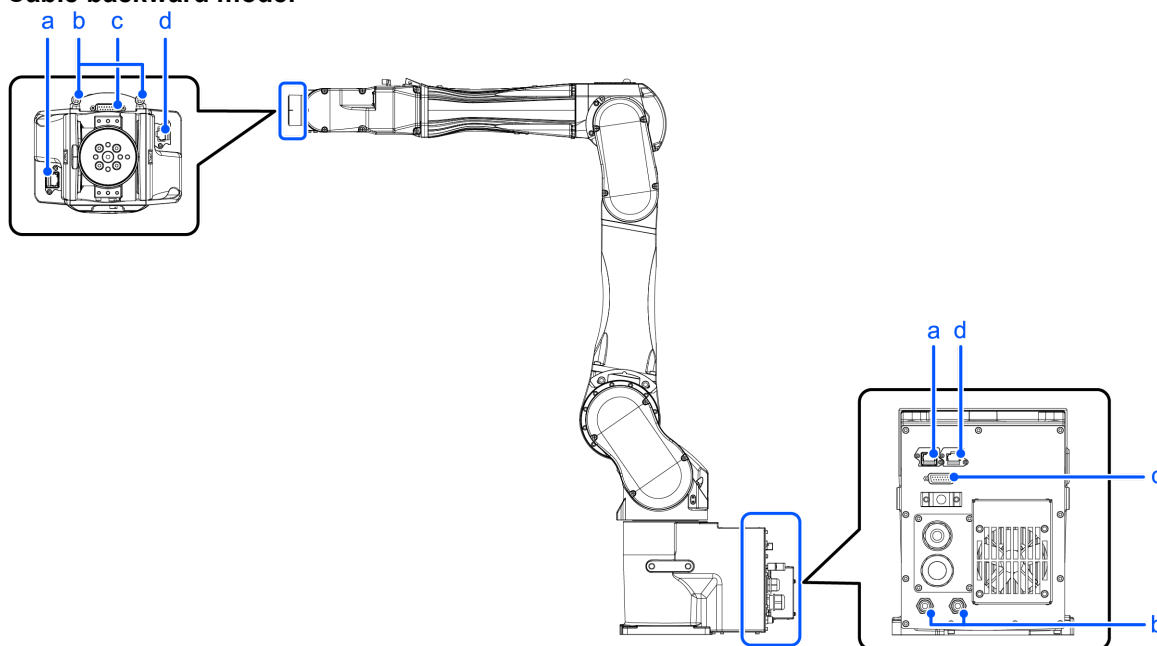

Cable downward model

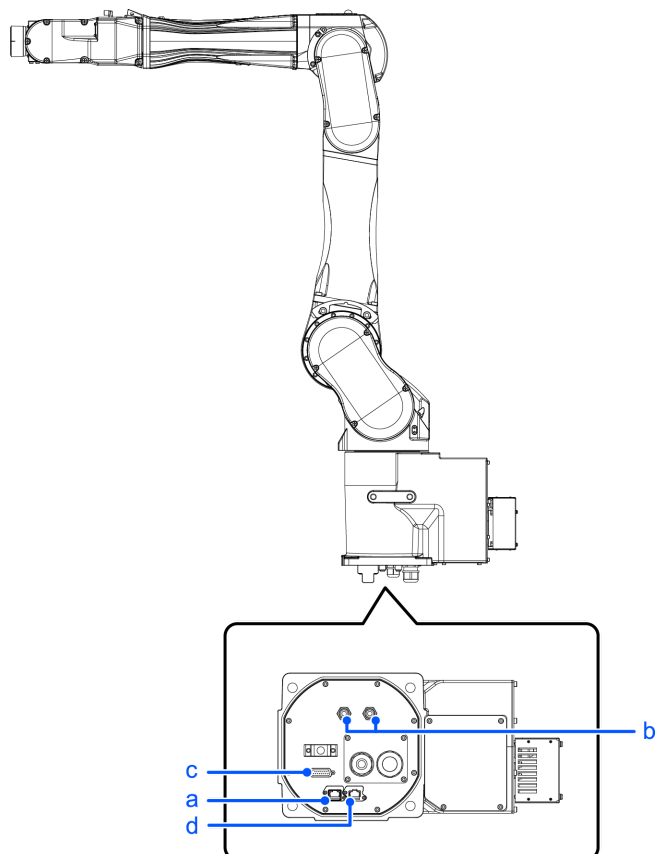

Symbol	Description
a	Force Sensor cable connector
b	Fitting for $\varnothing 6$ mm tube (Air1, Air2)
c	User cable connector (9-pin D-sub connector)
d	Ethernet cable connector

4.3.5.1 Electrical Wires

Specifications of the user wires D-sub 15-pin

Rated Voltage	Allowable Current	Wires	Nominal Sectional Area	Note
AC/DC30V	1 A	15	0.106 mm ²	Shielded

Pins with the same number, indicated on the connectors on both ends of the cables, are connected.

Attached connector for user wires (standard, cleanroom model)

		Manufacturer	Type	
15 pin	Connector	JAE	DA-15PF-N	(Solder type)
	Clamp hood	HRS	HDA-CTH (4-40) (10)	(Connector setscrew: #4-40 UNC)

Two parts are attached for each.

8-pin (RJ45) equivalent to Cat.5e

An Ethernet cable (commercially available) can be connected to Manipulator models with standard and cleanroom specifications.

Other

The 6-pin cable for the Force Sensor option is included.

4.3.5.2 Pneumatic Tubes

Maximum Working Pressure	Number of Tubes	Outer Diameter × Inner Diameter
0.59 MPa (6 kgf/cm ² : 86 psi)	2	ø6 mm × ø4 mm

The elbow fitting is attached on the Arm #4 at the time of shipment. The part can be replaced with the straight fitting (accessory) according to application.

4.3.6 Checking the Basic Orientation

After installing the Manipulator and setup the operating environment, check if it moves to the basic position properly.

Follow the steps below to set the basic orientation of the Manipulator shown below as the origin position.

1. Start Epson RC+.
Double click the [Epson RC+] icon on the desktop.
2. Open the command window.
Epson RC+ menu-[Tools]-[Command Window]
3. Execute the following command in [Command Window].

```
>Motor On
>Go Pulse (0,0,0,0,0,0)
```

 **KEY POINTS**

If "Error 4505: cannot be turned on the motor because the Safety Board is issuing a stop signal." occurs, use one of the following methods to move the Manipulator to its basic orientation.

- Release the brake and push the arm by hand to move it within the motion range. Then follow the steps above. For details on releasing brake, refer to the following section.
[How to Move Arms with the Electromagnetic Brake](#)
- Press the TP3 or TP4 command button [Pulse0] to move the Manipulator to its basic orientation. For details, refer to the following manual.
For TP3:
"Robot Controller Option Teach Pendant TP3 Operation 3.1.3 Command Buttons"
For TP4:
"Robot Controller Option Teach Pendant TP4 3.2.5.13.2 Command Buttons"
"Robot Controller Option Teach Pendant TP4 3.2.9.7.2 Command Buttons"

If the Manipulator cannot be in the basic orientation shown below, please contact the supplier.

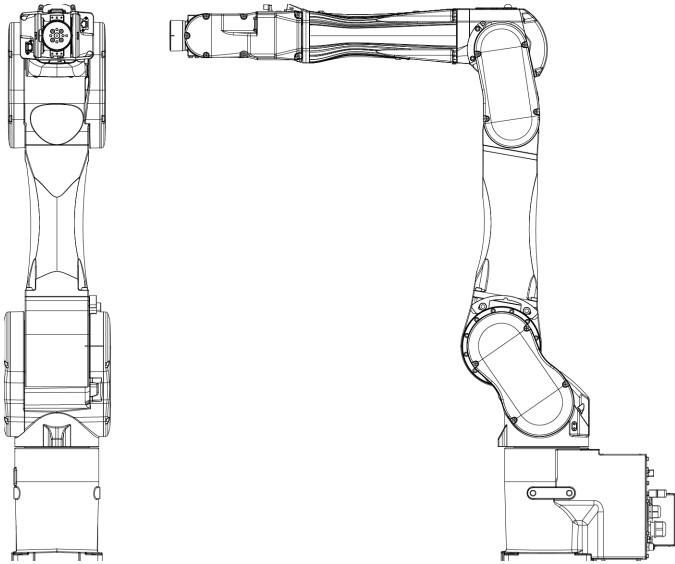

4.3.7 Relocation and Storage

4.3.7.1 Safety Information for Relocation and Storage

Pay attention to the following requirements when relocating, storing, and transporting the Manipulators.

Transportation and installation of the Manipulator and related equipment should be performed by people who have received installation training provided by Epson and the suppliers. Also, the laws and regulations of the installation country must be followed.

WARNING

- Only qualified personnel should perform sling work and operate a crane or a forklift. When these operations are performed by unqualified personnel, it is extremely hazardous and may result in serious bodily injury and/or severe equipment damage to the robot system

CAUTION

- Before relocating, fold the arm and secure it tightly with a cable tie to prevent hands or fingers from getting caught in the Manipulator.
- When removing the anchor bolts, support the Manipulator so that it does not fall. Removing the anchor bolts without supporting the Manipulator can cause it to fall, causing hands or feet to get caught.
- The Manipulator should be transported by two or more people or secured to transporting equipment. Also, do not hold the bottom of the base. Holding these parts by hand is extremely hazardous and may cause your hands and fingers caught.

During unpacking and relocation, avoid applying external force to the arms and motors of the Manipulator.

When transporting the Manipulator over long distances, secure it directly to transporting equipment so that it will not fall. If necessary, pack the Manipulator using the same packaging as delivery.

When the Manipulator is reassembled and used for a robot system again after an extended period of storage, perform a test run to verify that it works properly before starting the main operation.

Manipulators should be transported and stored under the following conditions: Temperature: -20 to +60°C, Humidity: 10 to 90% (no condensation)

If condensation has formed on the Manipulator during transportation or storage, do not turn on the power until the condensation is removed.

Do not subject the Manipulator to excessive impacts or vibrations during the transportation process.

Relocation

Follow the procedures described below when relocating the Manipulator.

1. Turn off the power for all devices and unplug the power cable connector and signal cable connector from the Controller. Do not remove the M/C cables (power cable and signal cable) from the Manipulator.

KEY POINTS

Remove the mechanical stops if using them to limit the motion range. For details on the motion range, refer to the following section.

Setting the Work Envelope by Mechanical Stops

2. Unscrew the anchor bolts. Then, remove the Manipulator from the base table.
3. Position the Manipulator as shown in the figure. Then, secure the Manipulator to the transporting equipment or have at least two people to relocate the Manipulator. (Recommend: Joint #2 +55°. Joint #3 -55°)

The posture is common to all models.

Do not hold the bottom of the base (the screened parts in the figure). Holding these parts by hand is extremely hazardous and may cause your hands and fingers caught.

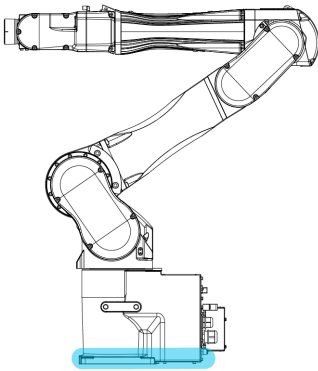

Manipulator weight: 63 kg: 139 lb

Using eyebolts

Check that the eyebolts are securely fastened before transporting the Manipulator. After transporting the Manipulator, remove the eyebolts and keep them for future use.

The eyebolts (accessory, 2 pcs) and wire must be strong enough to withstand the weight (See the figures below).

If you use the eyebolts to lift up the Manipulator, make sure to put hands on it to keep the balance. The Manipulator may fall if the balance is lost and this is extremely hazardous.

To prevent damage on the covers and arms, it is recommended to protect the contacting parts of the wire and arm with a cloth. Be very careful not to damage the covers since they are made of plastic.

Manipulator weight: 63 kg: 139 lb

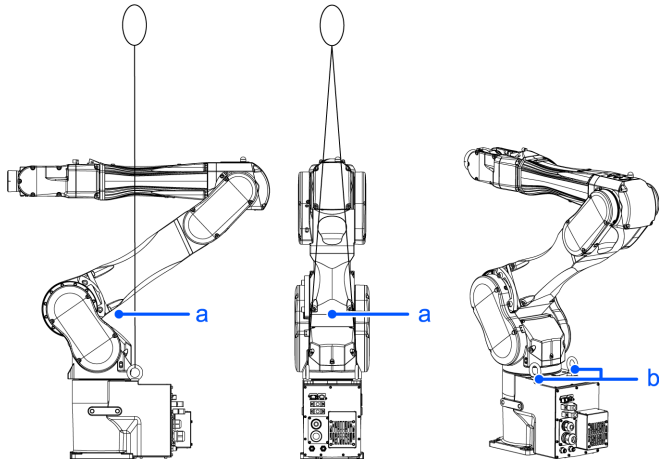

Symbol	Description
a	Center of gravity
b	Threaded holes for eyebolts: 2×M12 depth 25

Locations of the threaded holes for eyebolts are common to all models.

⚠ CAUTION

- Remove the eyebolts from the Manipulator after transportation/relocation is completed. If the Manipulator is operated with the eyebolts left on it, the arm may collide with the eyebolts and it may cause equipment damage to and/or malfunction of the Manipulator.

4.4 Setting the Hand

4.4.1 Installing the Hand

The hand (end effector) must be prepared by the customer. For details on attaching the hand, refer to the following manual. "Hand Function Manual"

Flange dimensions of the wrist attached to the end of Arm #6 is as below.

⚠ WARNING

- Before attaching a hand or peripheral equipment, be sure to always turn off the Controller and related equipment and unplug the power cables. Performing any work procedure with the power turned on is extremely dangerous and may result in electric shock and/or malfunction of the robot system.

⚠ CAUTION

- When the hand is equipped with a workpiece gripping mechanism, ensure that the wiring and pneumatic tubes do not cause the hand to release the workpiece when the power is turned off. When the wiring and pneumatic tubes are not designed for the hand to maintain its grip on the workpiece when the power is turned off, pressing the emergency stop switch releases the workpiece, which may damage the robot system and the workpiece.

By default, all I/Os are designed to automatically turn off (0) when the power is shut off, when an emergency stop is triggered, or by the robot system's safety function.

However, I/Os set with the Hand function does not turn off (0) when executing the Reset statement, or when performing an emergency stop.

For the risk of the residual air pressure, conduct a risk assessment on the equipment and take the necessary protective measures.

Wrist flange

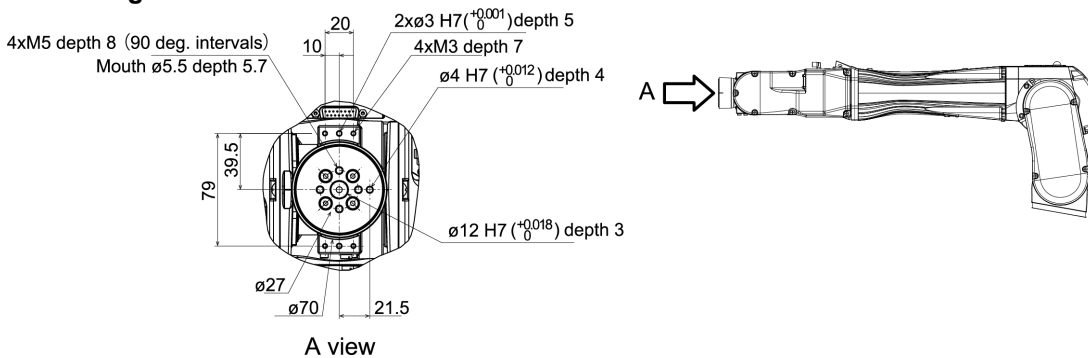

Arm #6

Attach the hand to the end of the Arm #6 using the M5 bolts.

Layout

When attaching and operating a hand, the hand may come into contact with the Manipulator body due to the outer diameter of the hand, the size of the workpiece, or the position of the arm. Carefully consider the interference area of the hand when designing the system layout.

Compatibility with ISO flange

To install the hand whose mounting dimensions are designed for the ISO flange, we provide the optional C8 ISO flange (J6). For details, refer to the following section.

Options

4.4.2 Attaching Cameras and Valves

Decks are equipped to Arms #3 and #5 to enable the easy installation of air valve. If the payload exceeds the maximum payload, refer to the following section.

"WEIGHT Setting - Restrictions on payload exceeding the maximum payload"

To mount the camera, the camera plate unit is necessary. We provide the optional Camera Plate Unit. For details, refer to the following section.

Options

(Units: mm)

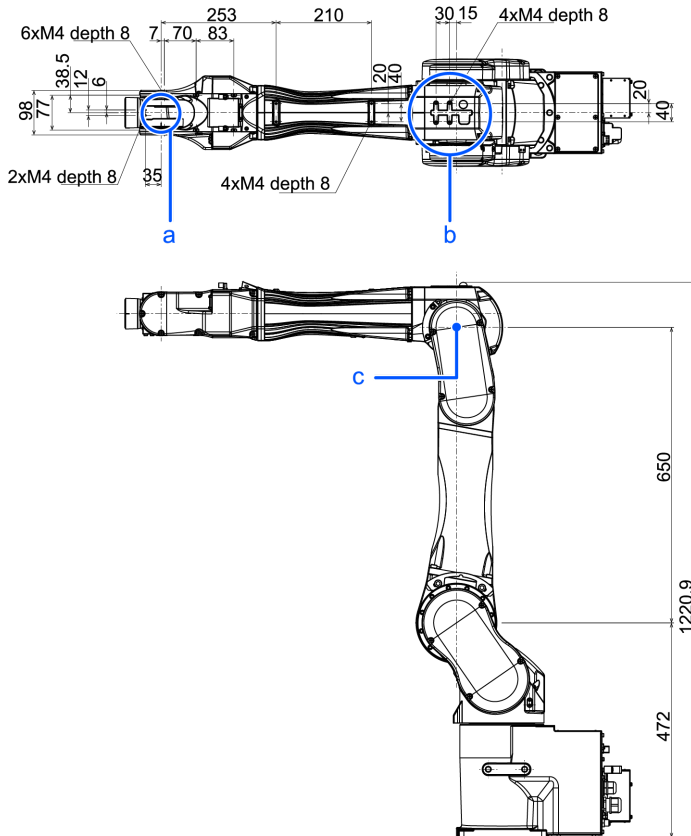

Symbol	Description
a	Arm #5 Deck
b	Arm #3 Deck
c	Rotation center of the upper arm

4.4.3 WEIGHT and INERTIA Settings

The WEIGHT and INERTIA commands are for setting the load parameters of the Manipulator. These settings optimize the Manipulator motion.

- **WEIGHT Setting**
The WEIGHT command is for setting the load weight. The more the load weight increases, the more the speed and acceleration/deceleration are reduced.
- **INERTIA Setting**
The INERTIA command is for setting the inertia moment and the eccentricity of the load. The more the inertia moment

increases, the more the acceleration and deceleration of the Arm #6 are reduced. The more the eccentricity increases, the more the acceleration and deceleration for the Manipulator movement are reduced.

To ensure that the Manipulator is functioning properly, keep the load (the sum of the weights of the hand and workpiece) and the moment of inertia of the load within the rated values, and do not allow for eccentricity from the center of the Arm #6. If the load or the inertia moment exceeds the ratings or if the load becomes eccentric, follow the steps below to set parameters.

- **WEIGHT Setting**
- **INERTIA Setting**

Setting parameters makes the operation of the Manipulator optimal, reduces vibration to shorten the operating time, and improves the capacity for larger loads. This also works to curb any persistent vibration that may occur when the hand and workpiece have a large moment of inertia.

You can also perform settings using the "Weight, Inertia, and Eccentricity/Offset Measurement Utility."

For details, refer to the following manual.

"Epson RC+ User's Guide - Weight, Inertia, and Eccentricity/Offset Measurement Utility"

The allowable load for C12 series Manipulators is up to 12 kg.

Due to the limitations of the moment and moment of inertia shown in the table below, the load (hand + workpiece) should also meet these conditions.

Allowable Load

Joint	Allowable moment	(GD ² /4) Allowable Moment of Inertia
Joint #4	25.0 N·m (2.55 kgf·m)	0.70 kg·m ²
Joint #5	25.0 N·m (2.55 kgf·m)	0.70 kg·m ²
Joint #6	9.8 N·m (1.0 kgf·m)	0.20 kg·m ²

Moment

The moment indicates amount of torque applied on the joint in order to support the gravity on the load hand + workpiece). The moment increases as weight of the load and amount of eccentricity increase. As this also increases the load applied on the joint, make sure to keep the moment within the allowable value.

Moment of inertia

The moment of inertia indicates how difficult the load (hand + workpiece) to rotate when the Manipulator joint starts to rotate (amount of inertia). The moment of inertia increases as weight of the load and amount of eccentricity increase. As this also increases the load applied on the joint, make sure to keep the moment within the allowable value.

The moment M (Nm) and moment of inertia I (kgm²) when the volume of the load (hand + workpiece) is small can be obtained by the following formula.

$$M \text{ (Nm)} = m \text{ (kg)} \times L \text{ (m)} \times g \text{ (m/s}^2\text{)}$$

$$I \text{ (kgm}^2\text{)} = m \text{ (kg)} \times L^2 \text{ (m)}$$

- m : Weight of load (kg)
- L : Eccentricity of load (m)
- g : Gravitational acceleration (m/s²)

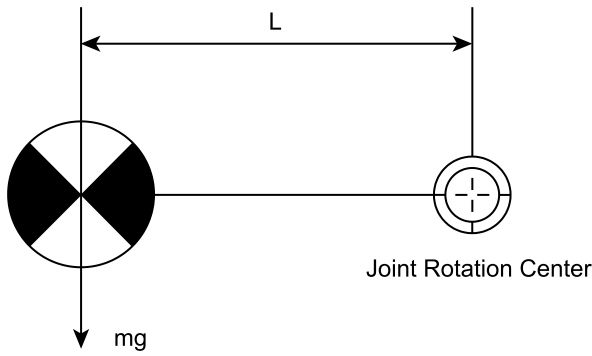

The figure below shows distribution of the center of gravity when the volume of the load (hand + workpiece) is small. Design the hand so that the center of gravity is within the allowable moment. If the volume of the load is large, calculate the moment and inertia moment by referring to the following section.

"INERTIA Setting - Calculating the Moment of Inertia"

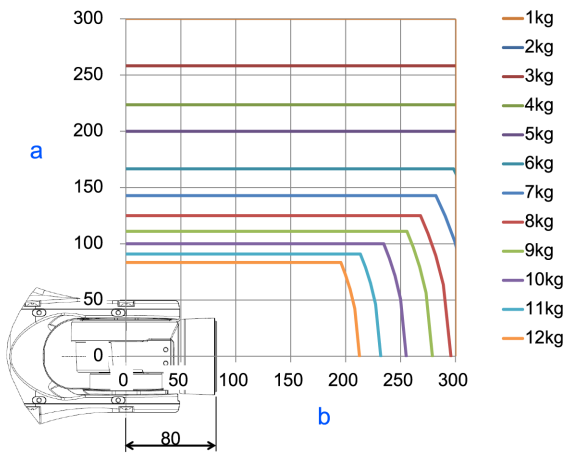

Symbol	Description
a	Distance from the center of Arm #* rotation [mm]
b	Center of gravity of load from the Arm #* rotation center [mm]

Max. Eccentricity of Load (Distance between the joint rotation center and the load’s center of gravity)

Joint	1 kg	3 kg	5 kg	8 kg	10 kg	12 kg
#4	300 mm	300 mm	300 mm	296 mm	255 mm	213 mm
#5	300 mm	300 mm	300 mm	296 mm	255 mm	213 mm
#6	300 mm	258 mm	200 mm	125 mm	100 mm	83 mm

When calculating the critical dimension of the load using the allowable moment and inertia moment, the calculated value represents a distance from the Arm #6 rotation center, not the distance from the flange. To calculate the distance from the flange to the load’s center of gravity, subtract the distance from the center of the Arm #5 rotation center to the flange (=80 mm) as shown in the example below.

Example: Calculation of the critical dimension of the load (A) when the load is 12 kg.

Center of gravity by the allowable moment control: $25.0 \text{ N}\cdot\text{m} / (12 \text{ kg} \times 9.8 \text{ m/s}^2) = 0.212 \text{ m} = 212 \text{ mm}$

Center of gravity by the allowable inertia moment control: $(0.70 \text{ kgm}^2 / 12 \text{ kg})^{1/2} = 0.241 \text{ m} = 241 \text{ mm}$

Due to the allowable moment control, center of gravity for the load limit is 212 mm from the Arm #5 rotation center.

Distance from the flange to the center of gravity for the load limit A = 212 mm - 80 mm = 132 mm

Critical Dimension of Load

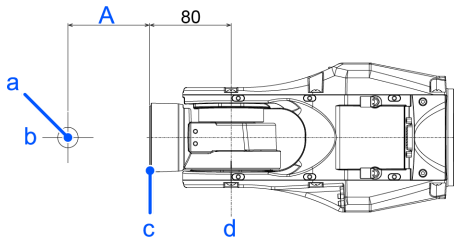

(Units: mm)

Symbol	Description
a	Load center of gravity position
b	Arm #6 rotation center
c	Flange
d	Arm #5 rotation center

4.4.3.1 WEIGHT Setting

⚠ CAUTION

- Set the total weight of the hand and the workpiece smaller than the maximum payload. The C12 series Manipulators can operate without limitations on the condition unless and until the load exceeds this maximum payload. Always set the Weight parameters of the WEIGHT command according to the load. Setting a value smaller than the actual weight may cause errors or impact that not only impair full functionality but also shorten the life of the mechanical components.

The acceptable weight capacity (hand + workpiece) for C12 series Manipulators is as follows:

Rated	Maximum
3 kg	12 kg

Change the setting of the Weight parameter according to the load. After changing the Weight parameter setting, the maximum acceleration/deceleration and speed of the robot system is set automatically.

Setting method of Weight parameters

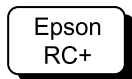

Select [Tools]-[Robot Manager]-[Weight] panel and set the value in [Weight:]. You may also execute the Weight command from [Command Window].

Load on the Manipulator

Mounting location of the load

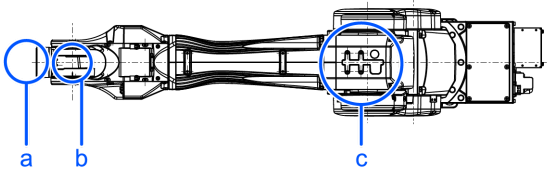

Symbol	Description
a	Load on the fore end of Arm #6
b	Arm #5 deck
c	Arm #3 deck

Deck detailed

(Units: mm)

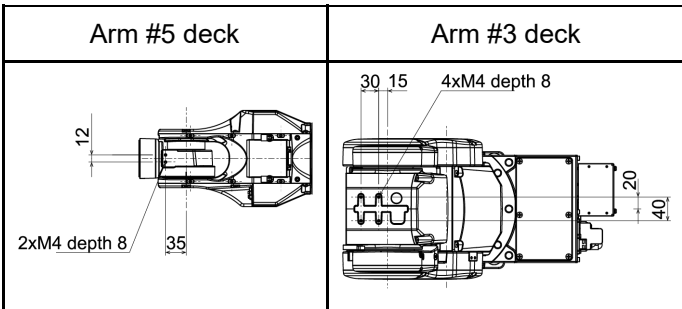

When you attach the equipment to the decks on the upper arm, convert its weight into equivalent weight assuming that the equipment is attached to the end of the Arm #6. Then, this equivalent weight added to the load will be a Weight parameter.

Calculate the Weight parameter by using the formula below and enter the value.

Weight Parameter Formula

Weight parameter = $M_w + W_a + W_b$

- M_w : Payload on the fore end of Arm #6 (kg)
- W_a : Equivalent weight of the Arm #3 deck (kg)
- W_b : Equivalent weight of the Arm #5 deck (kg)
- $W_a = M_a (L_a)^2 / (L)^2$
- $W_b = M_b (L_b)^2 / (L)^2$
- M_a : Weight of the air valve on the Arm #3 deck (kg)
- M_b : Weight of the camera on the Arm #5 deck (kg)
- L: Length of the upper arm (315 mm)
- L_a : Distance between the Joint #3 and the center of gravity of the air valve on the Arm #3 deck (mm)
- L_b : Distance between the Joint #3 and the center of gravity of the camera on the Arm #5 deck (mm)

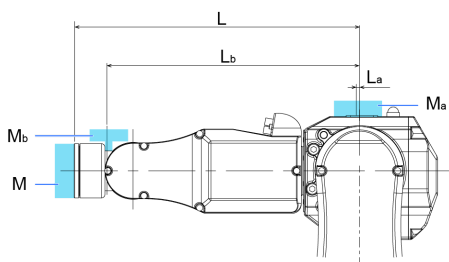

[Example] When the following loads apply to C12-B1401** (C12XL) which fore end of the Arm #6 is 730 mm (L) away from the Joint #3 and payload (M_w) is 5 kg:

- Load on the Arm #3 deck is 1.5 kg (M_a). The deck is 0 mm (L_a) away from the Joint #3.
- Load on the Arm #5 deck is 1.0 kg (M_b). The deck is 690 mm (L_b) away from the Joint #3.

$$W_a = 1.5 \times 0^2 / 730^2 = 0$$

$$W_b = 1.0 \times 690^2 / 730^2 = 0.89 \rightarrow 0.9 \text{ (round up)}$$

$$M_w + W_a + W_b = 5 + 0 + 0.9 = 5.9$$

Enter "5.9" for the Weight parameter.

Automatic speed setting by Weight parameter

The percentage in the graph is based on the speed at rated weight (3 kg) as 100%.

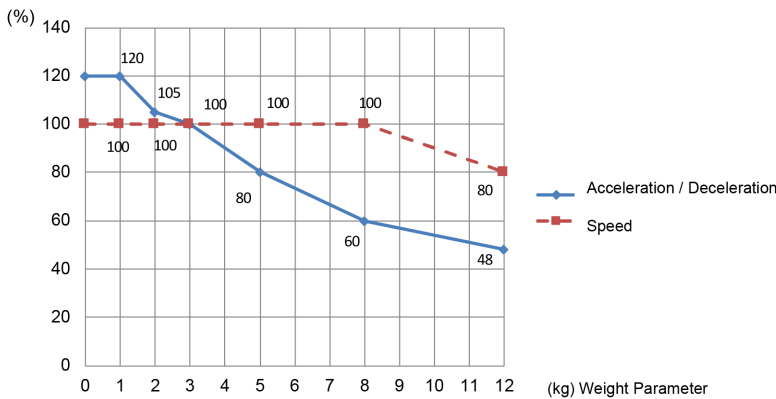

KEY POINTS

Maximum AccelS setting value varies depending on Weight setting value. For details, refer to the following section.

[C12 Specifications](#)

4.4.3.2 INERTIA Setting

Moment of Inertia and INERTIA Setting

The moment of inertia is a quantity that expresses how hard it is for an object to turn, and it is expressed in terms of values for the moment of inertia, inertia, or GD^2 . When a hand or other object is attached to the Arm #6 for operation, the moment of inertia of the load must be taken into consideration.

CAUTION

- The moment of inertia of the load (hand + workpiece) must be $0.2 \text{ kg} \cdot \text{m}^2$ or less.

The C12 Manipulators are not designed to work with a moment of inertia exceeding $0.2 \text{ kg} \cdot \text{m}^2$. Always set the value corresponding to the moment of inertia. Setting a parameter value that is smaller than the actual moment of inertia may cause errors or impact, may prevent the Manipulator from working at full functionality, and may shorten the lifespan of mechanical parts.

The allowable moment of inertia of a load for C12 Manipulators is $0.03 \text{ kg}\cdot\text{m}^2$ at the default rating and $0.2 \text{ kg}\cdot\text{m}^2$ at the maximum. Change the setting of the moment of inertia according to the inertia moment of the load using the INERTIA command. After the setting is changed, the maximum acceleration/deceleration of Arm #6 that corresponds to the "Inertia" value is corrected automatically.

Moment of Inertia of Load Attached to Arm #6

The moment of inertia of the load (hand + workpiece) attached to the Arm #6 can be set by the "Inertia" parameter in the Inertia statement.

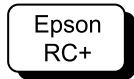

Go to [Tools] - [Robot Manager] - [Inertia] panel, and enter the value in [Inertia]. This can also be set using the Inertia statement in [Command Window].

Eccentricity and INERTIA Setting

⚠ CAUTION

- The eccentricity of the load (hand + workpiece) must be 300 mm or less. The C12 series Manipulators are not designed to work with eccentricities exceeding 300 mm. Always set the value based on the eccentricity. Setting the eccentricity parameter to a value smaller than the actual eccentricity may cause errors or impact that not only impair full functionality but also shorten the life of the mechanical components.

The allowable eccentricity of load for C12 Manipulators is 50 mm at the default rating and 300 mm at the maximum. When the load eccentricity exceeds the rating, change the setting for the eccentricity parameter in Inertia statement. After the setting is changed, the maximum acceleration/deceleration of the Manipulator that corresponds to the "Eccentricity" is corrected automatically.

Eccentricity

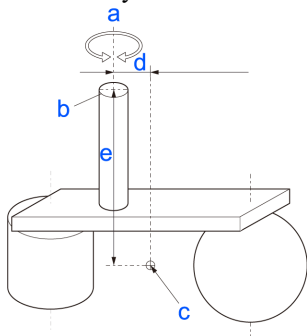

Symbol	Description
a	Rotation axis
b	Flange
c	Load center of gravity position
d, e	Eccentricity (300 mm or less) To set the parameter, enter the larger value of "d" or "e".

Eccentricity of Load Attached to Arm #6

The eccentricity of the load (hand + workpiece) attached to the Arm #6 can be set by the "Eccentricity" parameter in the Inertia statement.

Enter the larger value of either "d" or "e" in the figure above to [Eccentricity].

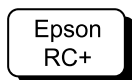

Go to [Tools] - [Robot Manager] - [Inertia] panel, and enter the value in [Eccentricity]. This can also be set using the Inertia statement in [Command Window].

Automatic Acceleration/Deceleration Correction at INERTIA (Eccentricity) Setting

Automatic setting by inertia moment setting

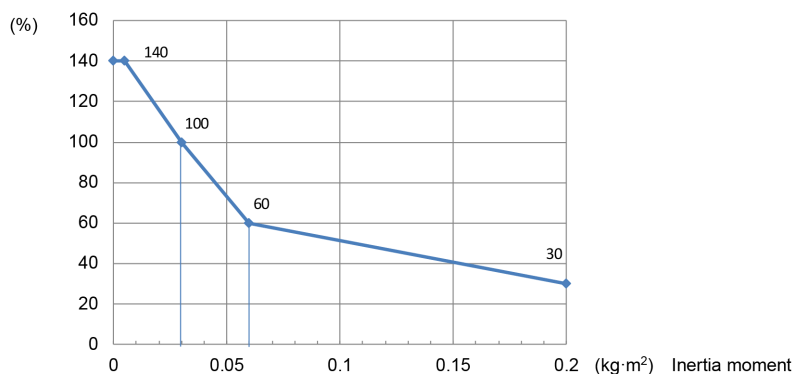

* The percentages on the graph are ratios based on 100% as the acceleration/deceleration at the rated (0.03 kg·m²) setting.

Automatic setting by eccentricity setting

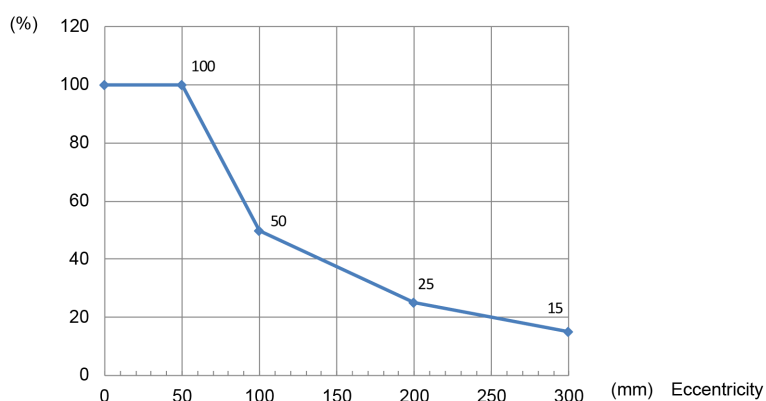

* The percentages on the graph are ratios based on 100% as the acceleration/deceleration at the rated (50 mm) setting.

Calculating the Moment of Inertia

An example of calculating the moment of inertia of a load (hand holding a workpiece) is shown below.

The moment of inertia of the entire load is calculated by the sum of (A), (B), and (C).

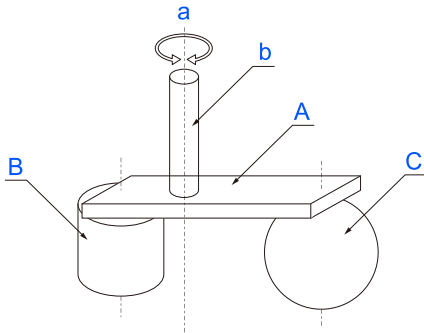

$$\text{Whole moment of inertia} = \text{Moment of inertia of end effector (A)} + \text{Moment of inertia of work piece (B)} + \text{Moment of inertia of work piece (C)}$$

Symbol	Description
a	Rotation axis
b	Shaft
A	Hand
B	Workpiece
C	Workpiece

The methods for calculating the moment of inertia for (A), (B), and (C) are shown below. Use the moment of inertia of these basic shapes as a reference to find the moment of inertia of the entire load.

(A) Moment of inertia of a rectangular parallelepiped

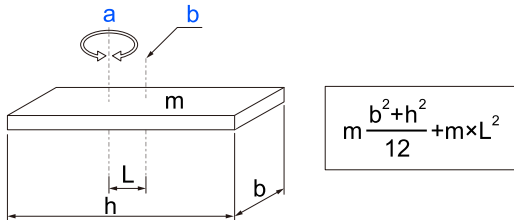

Symbol	Description
a	Rotation axis
b	Center of gravity of rectangular parallelepiped
m	Weight

(B) Moment of inertia of a cylinder

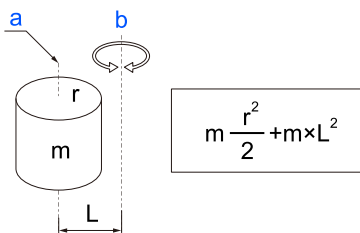

Symbol	Description
a	Center of gravity of cylinder

Symbol	Description
b	Rotation axis
m	Weight

(C) Moment of inertia of a sphere

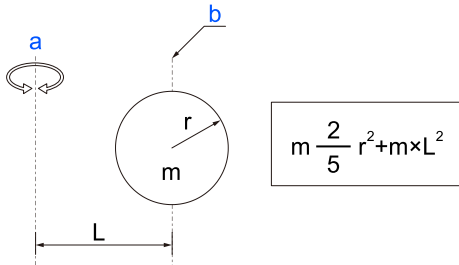

Symbol	Description
a	Rotation axis
b	Center of gravity of sphere
m	Weight

4.4.4 Safety Information for Auto Acceleration

The speed and acceleration/deceleration of the Manipulator motion are automatically optimized according to the values of WEIGHT and INERTIA and the Manipulator’s postures.

WEIGHT Setting

The speed and acceleration/deceleration of the Manipulator are controlled according to the load weight set by the WEIGHT command. The more the load weight increases, the more the speed and acceleration/deceleration are reduced to prevent residual vibration.

INERTIA Setting

The acceleration/deceleration of Arm #6 are controlled according to the inertia moment set by the INERTIA command. The acceleration/deceleration of the whole Manipulator are controlled according to the eccentricity set by the INERTIA command. The more the inertia moment and eccentricity of the load increase, the more the acceleration/ deceleration are reduced.

Auto Acceleration/Deceleration According to Manipulator’s Posture

The acceleration/deceleration are controlled according to the Manipulator’s posture. When the Manipulator extends its arms or when the movement of the Manipulator produces vibration frequently, the acceleration/deceleration are reduced.

Set appropriate values for WEIGHT and INERTIA so that the Manipulator operation is optimized.

4.5 Work Envelope

⚠ WARNING

- Do not operate the Manipulator with the mechanical stop removed. Removing the mechanical stop is extremely dangerous because the Manipulator may move to a position outside its normal work envelope.

⚠ CAUTION

- When restricting the work envelope for safety reasons, be sure to make settings using both the pulse range and mechanical stop.

The work envelope is preset at the factory as explained in the following section. This is the maximum work envelope of the Manipulator.

Standard Work Envelope

The work envelope can be set by one of the following three methods.

- Setting by pulse range (for each joint)
- Setting by mechanical stops
- Setting the rectangular range in the XY coordinate system of the Manipulator

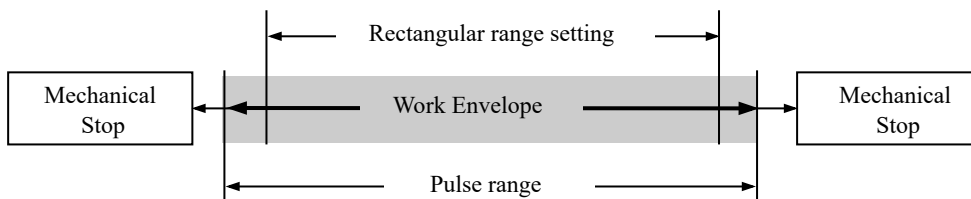

To limit the work envelope for layout efficiency or safety reasons, make the settings as explained in the following sections.

- Work Envelope Setting by Pulse Range (for Each Joint)**
- Setting the Work Envelope by Mechanical Stops**
- Restriction of Manipulator Operation by Joint Angle Combination**
- Coordinate System**

4.5.1 Work Envelope Setting by Pulse Range (for Each Joint)

Pulses are the basic unit of Manipulator motion. The motion range (work envelope) of the Manipulator is set by the pulse lower limit value and pulse upper limit value (pulse range) for each joint. Pulse values are read from the encoder output of the servomotor.

Be sure to set the pulse range within the mechanical stop range.

✎ KEY POINTS

- The Arm #1 and #4 do not have a mechanical stop.
- Once the Manipulator receives a motion command, it checks whether the target position specified by the command is within the pulse range before operating. If the target position is outside of the pulse range that was set, an error occurs and the Manipulator does not move.

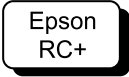

Go to [Tools] - [Robot Manager] - [Range] panel, and make the setting. This can also be set using the Range statement in [Command Window].

4.5.1.1 Joint #1 Maximum Pulse Range

With the 0 pulse as a starting point, the counterclockwise pulse value is defined as positive (+), and the clockwise pulse value is defined as negative (-).

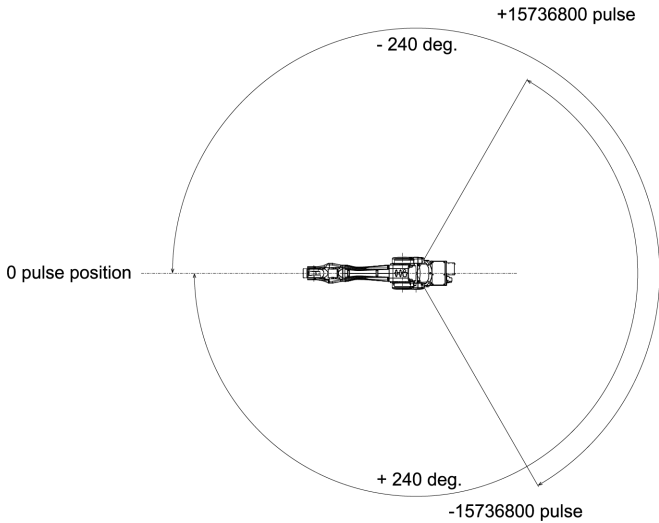

4.5.1.2 Joint #2 Maximum Pulse Range

With the 0 pulse as a starting point, the clockwise pulse value is defined as positive (+), and the counterclockwise pulse value is defined as negative (-).

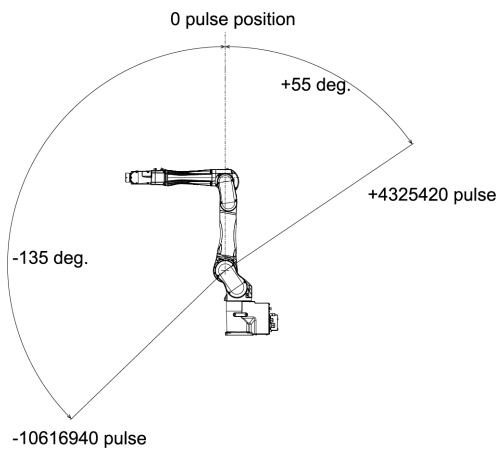

4.5.1.3 Joint #3 Maximum Pulse Range

With the 0 pulse as a starting point, the clockwise pulse value is defined as positive (+), and the counterclockwise pulse value is defined as negative (-).

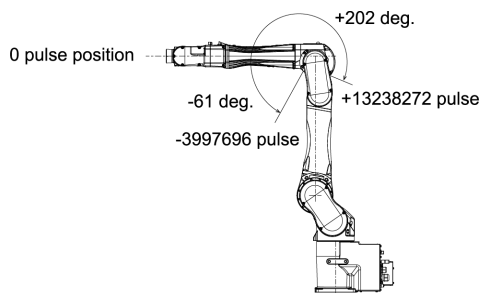

4.5.1.4 Joint #4 Maximum Pulse Range

From the angle of arm end, with the 0 pulse as a starting point, the clockwise pulse value is defined as positive (+), and the counterclockwise pulse value is defined as negative (-).

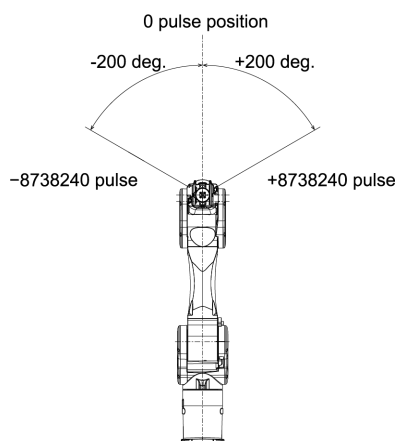

4.5.1.5 Joint #5 Maximum Pulse Range

With the 0 pulse as a starting point, the clockwise pulse value is defined as positive (+), and the counterclockwise pulse value is defined as negative (-).

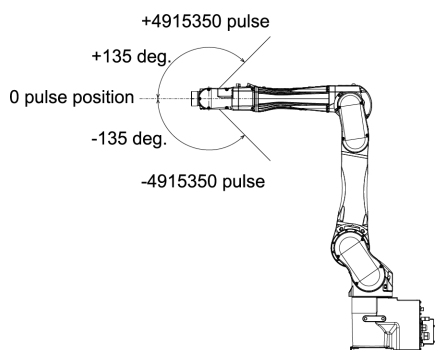

4.5.1.6 Joint #6 Maximum Pulse Range

From the angle of arm end, with the 0 pulse as a starting point, the clockwise pulse value is defined as positive (+), and the counterclockwise pulse value is defined as negative (-).

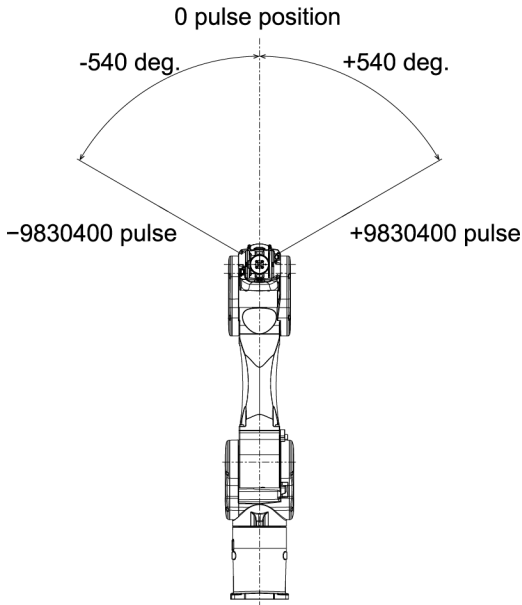

4.5.2 Setting the Work Envelope by Mechanical Stops

Using the variable mechanical stops physically limits the absolute area that the Manipulator can move.

Before starting any work, be sure to turn off the Manipulator.

Use bolts conforming to the specified length and surface processing (ex: nickel plating) with high corrosion resistance.

Specify the pulse range again after changing the position of the mechanical stop.

For details on the pulse range setting, refer to the following section.

Work Envelope Setting by Pulse Range (for Each Joint)

Be sure to set the pulse range inside the positions of the mechanical stop range.

4.5.2.1 Setting the Joint #1 Work Envelope

Install variable mechanical stop (J1) in the threaded holes corresponding to the angles to be set.

Normally a mechanical stop is not equipped.

- Hexagon socket head cap bolt: M12×30×2 bolts
- Strength: Compliant with ISO 898-1 property class: 10.9 or 12.9
- Tightening torque: 42.0 ± 2.1 N·m (428 ± 21 kgf·cm)

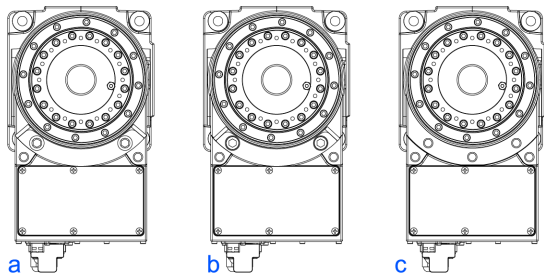

	a	b	c
Angle (°)	±110	±105	±240
Pulse	±7212700	±6884840	±15736800

	a	b	c
Variable Mechanical Stop (J1)	Applied	Applied	Not applied (standard)

4.5.2.2 Setting the Joint #2 Work Envelope

Remove the mechanical stop installed as standard and install the variable mechanical stop (J2). (Joint #2 standard work envelope -135 to +55°)

- Hexagon socket head cap bolt: M10×35×2 bolts
- Strength: Compliant with ISO 898-1 property class: 10.9 or 12.9
- Tightening torque: 32.0 ± 1.6 N·m (326 ± 16 kgf·cm)

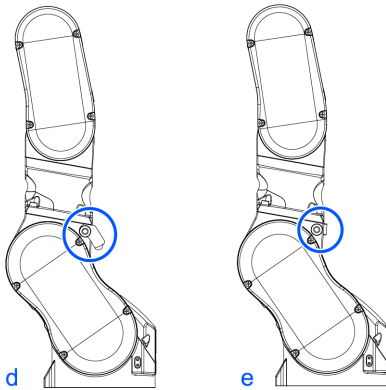

	d	e
Angle (°)	-125, +45	-135, +55
Pulse	-9830500, +3538980	-10616940, +4325420
Variable Mechanical Stop (J2)	Applied	Applied (standard)

4.5.2.3 Setting the Joint #3 Work Envelope

Remove the mechanical stop installed as standard and install the variable mechanical stop (J3). (Joint #3 standard work envelope -61 to +202°)

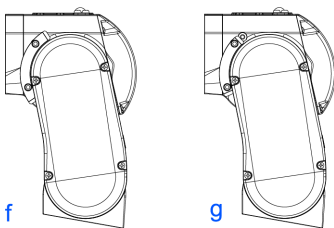

- Hexagon socket head cap bolt: M6×15×2 bolts
- Strength: Compliant with ISO 898-1 property class: 10.9 or 12.9
- Tightening torque: 13.0 ± 0.6 N·m (133 ± 6 kgf·cm)

	f	g
Angle (°)	-51, +192	-61, +202
Pulse	-3342336, +12582912	-3997696, +13238272
Variable Mechanical Stop (J3)	Applied	Applied (standard)

4.5.3 Restriction of Manipulator Operation by Joint Angle Combination

To prevent the arms of the Manipulator from interfering each other, the Manipulator operation is restricted in the specified motion range according to the angle combination of the Joint #1, #2, and #3.

The Manipulator operation is restricted and the Manipulator stops when the joint angles are within the colored areas in the following figure.

The restriction to Manipulator operation is enabled:

- During CP motion command execution
- When you attempt to execute the motion command for moving the Manipulator to a target point (or pose) in the specified motion range.

The restriction to the Manipulator operation is disabled:

- The Arms of the Manipulator momentarily go through the specified motion range during the PTP motion command execution even though the joint angles of the Arms are in the colored areas of the figures above.

Combination of Joint #2 and #3

- -110 deg. $\leq J1 \leq 110$ deg.

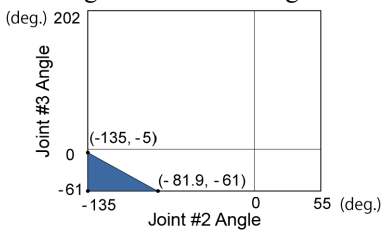

- -140 deg. $< J1 < 110$ deg. or 110 deg. $< J1 < 140$ deg.
 -240 deg. $< J1 < -220$ deg. or 220 deg. $< J1 < 240$ deg.

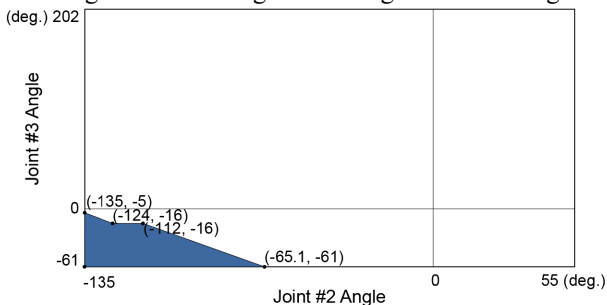

- -220 deg. $\leq J1 \leq -140$ deg. or 140 deg. $< J1 < 220$ deg.

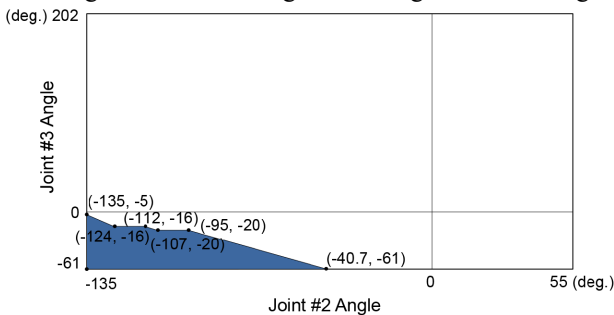

(deg.=°)

4.5.4 Coordinate System

The origin point is where the Manipulator’s installation face intersects with the rotation axis of Joint #1.

For details on the coordinate system, refer to the Epson RC+ Users Guide manual.

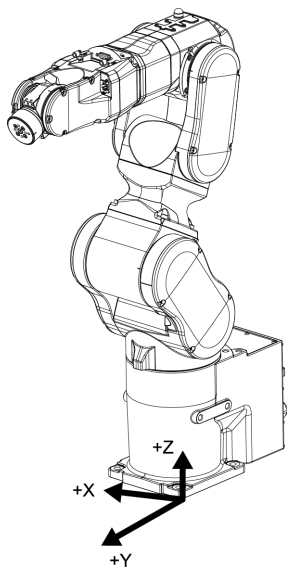

4.5.5 Changing the Robot

This section describes how to change the Manipulator model on Epson RC+.

CAUTION

Changing the Manipulator should be done with great caution. It initializes the robot calibration parameters (Hofs, CalPIs), additional axis information, and PG parameter data. Before changing the robot, make sure to save the calibration data by following the procedure below.

1. Select the Epson RC+ menu-[Setup]-[System Configuration].
2. Select [Controller]-[Robots]-[Robot**]-[Calibration] from the tree list. Then, click [Save].

1. Select the Epson RC+ menu-[Setup]-[System Configuration].
2. Select [Controller]-[Robots]-[Robot**] from the tree list. (Dialog image: Epson RC+ 8.0)

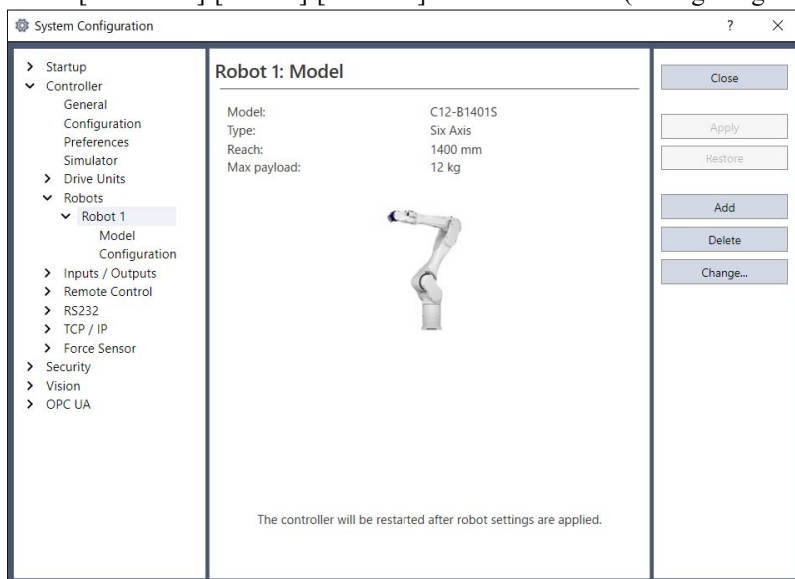

3. Click the [Change] button. The following dialog box will be displayed.

4. Input the robot name and serial number printed on the name plate of the Manipulator. Any serial number can be entered. However, enter the number printed on the Manipulator.

5. Select the robot type in the [Robot type] box.

6. Select the series name of the Manipulator in the [Series] box.

7. Select the robot model in the [Model] box.

Available robots will be displayed according to the format of the currently installed motor driver. When [Dry run] is used, all the Manipulators of the series selected in Step 6 will be displayed.

8. Click the [OK] button. The Controller is restarted.

4.5.6 Setting the Rectangular Range in the XY Coordinate System of the Manipulator

The Cartesian (rectangular) range in the XY coordinate system of the Manipulator is specified by the limited Manipulator operation area and the XY LIM setting. The limited Manipulator operation area is defined so that the hand does not interfere with the rear side of the Manipulator. The XY LIM setting that you can determine the upper and lower limits of the X and Y coordinates.

These settings are software-based limit, and so it does not change the maximum physical range. The maximum physical range is based on the position of the mechanical stops.

These settings are disabled during a joint jogging operation. Therefore, be careful not to allow the hand to collide with the Manipulator or peripheral equipment.

Epson
RC+

Go to [Tools] - [Robot Manager] - [XYZ Limits] panel, and make the setting. This can also be set using the XYLim statement in [Command Window].

4.6 Options

C12 series Manipulator has the following options.

- **Brake Release Unit**
- **Camera Plate Unit**
- **Tool Adapter (ISO flange)**
- **Variable Mechanical Stop**
- **User Wires and Pneumatic Tubes**

4.6.1 Brake Release Unit

While the electromagnetic brake is on (such as in emergency mode), you cannot move any arm by pushing manually. You can move the Arms by hand using the brake release unit while the Controller power is off or right after unpacking.

KEY POINTS

Precautions regarding the brake release unit

- Be sure to prepare at least one set of the brake release unit.
- Place at easy-to-reach location so that you can use it immediately when in a emergency situation.

WARNING

- Turn off the power to the Robot Controller and brake release unit when connecting or replacing the brake release unit or external short connector. Inserting or removing connectors with the power on may result in electric shock and/or malfunction of the robot system.

CAUTION

- Normally, release the brakes of joints one at a time. If the brakes of two or more joints must be released simultaneously due to unavoidable reasons, use extreme care. Releasing the brakes of multiple joints simultaneously may cause the arm to fall in an unexpected direction, resulting in hands or fingers getting caught or damage or failure of the Manipulator.
- After releasing the brake, the arm may fall by its own weight or move to the unexpected direction. Make sure to prepare a countermeasure to prevent the arm from falling and check the operation environment is safe.

Width	180 mm
Depth	150 mm
Height	87 mm
Weight (Cables are not included.)	1.7 kg
Cable to the Manipulator	2 m
M/C Short Connector	For M/C power cable short-circuit

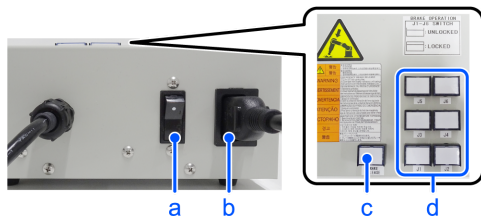

Symbol	Description
a	Power switch
b	Power Cable (You must provide.)
c	Power lamp

Symbol	Description
d	Brake release switch

4.6.1.1 Power Cable

You must provide a power cable. Be sure to use the specifications below.

Symbol	Item	Specifications
a	Plug	Comply with local safety regulation <ul style="list-style-type: none"> Class I (2P + PE), AC250 V, 6 A or 10 A Ex.: CEE Pub.7 Certified, CCC Certified, KC Certified, BS1363 Certified, PSB Certified, BIS Certified, SABS Certified Class I (2P + PE), AC125 V, 7 A, 12 A, or 15 A etc. Ex.: UL Certified, PSE Certified, BSMI Certified
b	Flexible cable	Comply with IEC/EN standards or local safety regulation Example: <ul style="list-style-type: none"> IEC 60227-1: General requirements IEC 60227-5: Polyvinyl chloride insulated cables of rated voltages up to and including 450/750 V - Part 5: Flexible cables (cords) EN 50525-1: General requirements EN 50525-2-11: Electric cables - Low voltage energy cables of rated voltages up to and including 450/750 V (Uo/U) - Part 2-11: Cables for general applications - Flexible cables with thermoplastic PVC insulation
c	Appliance coupler	Comply with IEC/EN standards or local safety regulation <ul style="list-style-type: none"> IEC / EN 60320-1: Appliance couplers for household and similar general purposes - Part 1: General requirements Standard Sheet C13: AC250 V/10 A

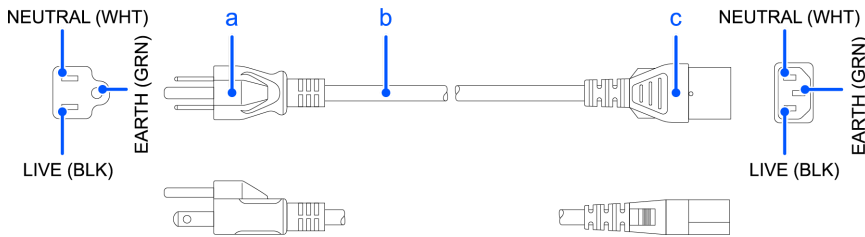

For Japan

Item	Specifications
Plug	PSE Certified Class I (2P+PE), AC125 V, 7 A or higher
Code	PSE Certified 0.75 mm ² or more
Connector	PSE Certified IEC 60320-1 Standard Sheet C13: AC125 V/10 A or higher

Precautions for use

⚠ CAUTION

- Operating the Manipulator without a brake release unit or external short connector connected may cause the brake to fail to release, possibly damaging the brake.
After using the brake release unit, be sure to connect the external short circuit connector to the Manipulator or make sure to leave the connector for the brake release unit connected.
- Keep the external short connector. Otherwise you cannot release the brakes.
- If you turn on the brake release unit while the brake release switch is being pressed, an unintended arm may move downward. Before turning on the brake release unit, make sure that the brake release switch is not pressed.
- If you turn on the brake release unit without the connector, it may lead to the short for the male pin used in the connector. Before turning on the brake release unit, make sure that the connector is connected.

4.6.1.2 Installing the Brake Release Unit

1. Turn off the Controller.
2. **If the M/C power cable is not connected to the Controller:**
Connect the M/C short connector, or connect the Controller.
(Keep the Controller power off.)
The M/C short connector can be purchased singly.



- If the M/C power cable is already connected to the Controller:**
Go to the step (3).



3. Remove the external short connector.



4. Connect the brake release unit to the connector of the connection cable.



4.6.1.3 Removing the Brake Release Unit

1. Turn off the brake release unit.
2. Remove the power cable of the brake release unit.
3. Disconnect the brake release unit from the connector of the connection cable.
4. If the M/C short connector is connected to the M/C power cable, remove the short connector.
5. Connect the external short connector to the connector of the connection cable.

4.6.1.4 How to Use the Brake Release Unit

⚠ CAUTION

- After releasing the brake, the arm may fall by its own weight or move to the unexpected direction. Make sure to prepare a countermeasure to prevent the arm from falling and check the operation environment is safe.
- If the arm you released its brake moves awkwardly or faster than usual, stop the operation promptly and contact the supplier. The brake release unit may be broken. If you keep operating the Manipulator, it may lead to the breakdown of the Manipulator or you may get your hand or fingers caught.

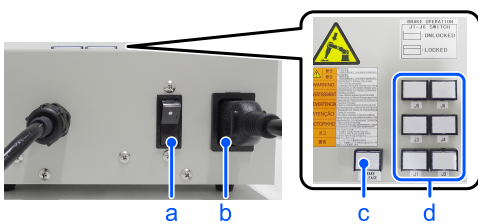

Symbol	Description
a	Power switch
b	Power cable (You must provide.)
c	Power lamp
d	Brake release switch

1. Refer to “Installing the Brake Release Unit” above to connect the brake release unit to the connector of the connection cable.
2. Plug the power cable into the brake release unit.
3. Plug the power cable into the power supply plug.

4. Turn on the brake release unit. When the brake release unit is enabled, the power lamp lights up.
5. Press the switch of the arm (J1 to J6) you want to move and then move the arm. Press the switch again. The brake will be released. The brake will be enabled by pressing the switch once again.

KEY POINTS

Move the arm the brake is released by two persons or more (one presses the switch and one moves the arm). The arm can be very heavy and needs the significant force to move.

4.6.2 Camera Plate Unit

To mount a camera to the C12 series Manipulator, you need to mount the camera plate unit first.

Appearance of arm end with camera

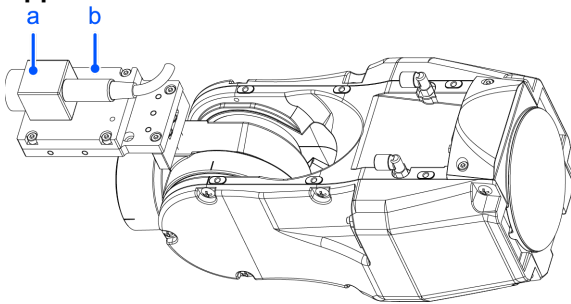

Symbol	Description
a	Camera
b	Camera Plate Unit

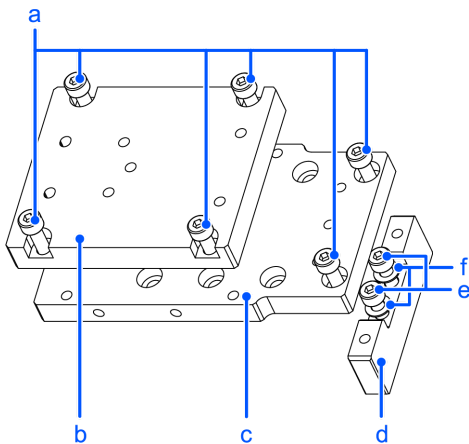

Parts Included		Qty.
a	Hexagon socket head cap bolt M4×12	6
b	Camera adapter plate	1
c	Camera mid plate	1
d	Camera base plate	1
e	Hexagon socket head cap bolt M4×20	2
f	Plain washer for M4 (small washer)	2

Installation

KEY POINTS

For details of tightening the hexagon socket head cap bolt, refer to the following section.

Tightening the Hexagon Socket Head Cap Bolts

Mounting holes for the camera base plate on the C12 series Manipulator

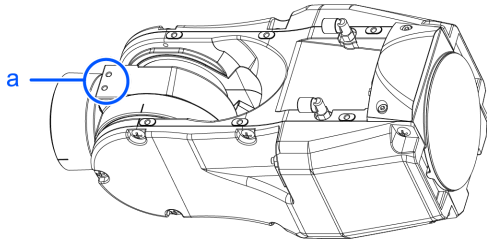

Symbol	Description
a	Mounting holes for the camera base plate

For installation procedure, refer to the following manual.
 "Epson RC+ Option Vision Guide Hardware & Setup"

Dimension of the camera plate unit

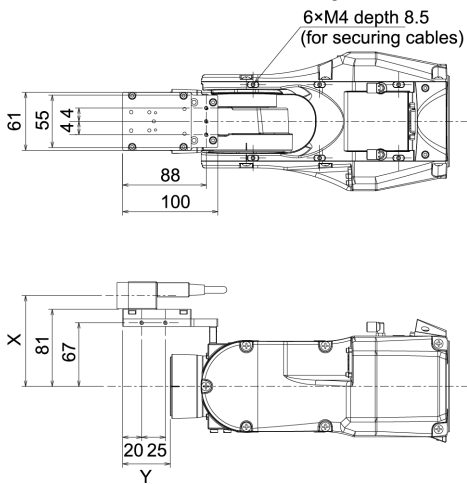

Dimensions X and Y will change depending on the position of camera mid plate and camera size. Refer to the table below for the values.

Camera mid plate

The camera mid plate uses the mounting holes A to D. By using the different mounting holes, it can be mounted to the camera base plate in the different four positions.

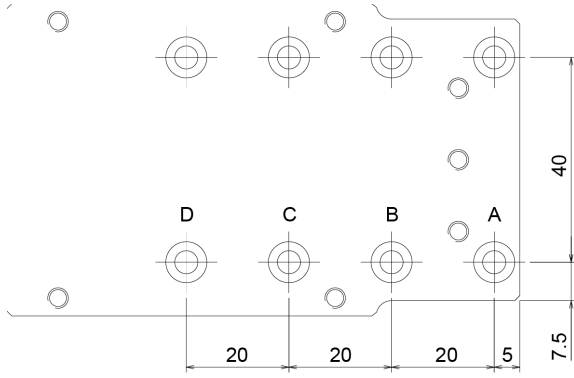

Camera and C12 series Manipulator Joint #5 motion range (reference values)

The Joint #5 motion range varies depending on the mounting position of camera mid plate and the camera you are using.

The table below shows the motion range (reference values) based on the available cameras for this option and the mounting positions of the camera mid plate. The values in the table may vary depending on how to secure the cables.

By changing the Y position, you can extend the distance from the hand mounting surface to the camera. Also, you can attach the larger hand. However, be careful about the Joint #5 motion range that will be limited in this case.

	A	B	C	D	X
USB Camera, GigE Camera	-135° to +70°	-135° to +60°	-135° to +45°	-135° to +35°	95.5 mm

	A	B	C	D
Y	50 mm	30 mm	10 mm	-10 mm

Direction of the Joint #5 motion

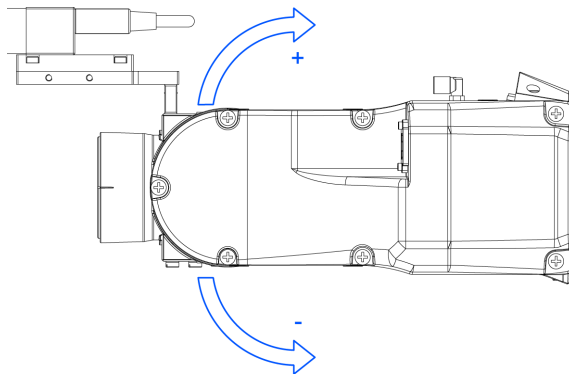

4.6.3 Tool Adapter (ISO flange)

Using the tool adapter, you can mount the hand whose dimensions are designed for the ISO flange to the C12 series Manipulators.

Parts Included	Qty.
ISO flange	1
Flange	1
Pin	2
Hexagon socket head cap bolt with low head M5×10	6

Parts Included	Qty.
Hexagon socket head cap bolt M5×15	4

Dimensions of ISO flange

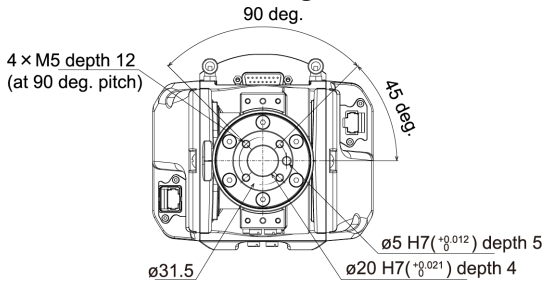

* Each dimension and tolerance complies with ISO9409-1-31.5-4-M5.

ISO flange installation

KEY POINTS

For details of tightening the hexagon socket head cap bolt, refer to the following section.

Tightening the Hexagon Socket Head Cap Bolts

1. Press-fit the pin to the Arm #6 end flange.

Pin protrusion: 4 mm from the flange

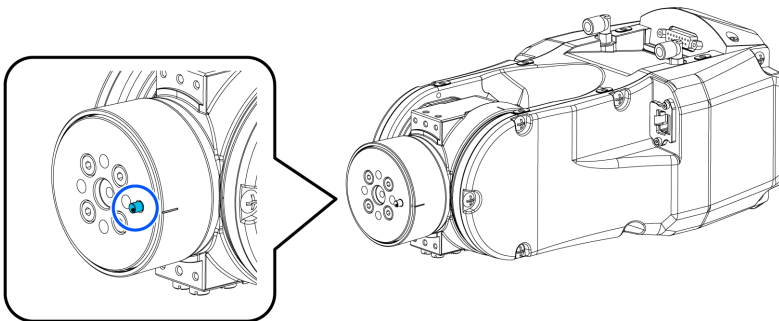

2. Align the pin and the pin hole on the flange, and then mount the flange.

Hexagon socket head cap bolt: 4×M5×15

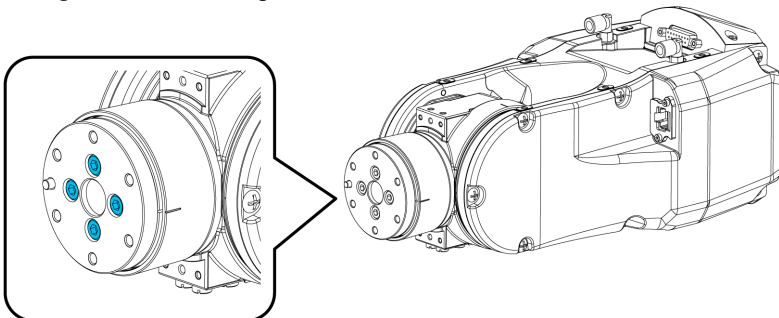

3. Press-fit the pin to the installed flange.

Pin protrusion: 4 mm from the flange

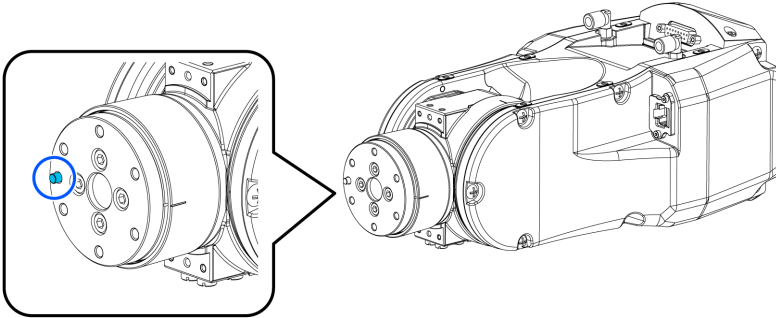

4. Align the pin and the pin hole on the ISO flange, and then mount the ISO flange.

Hexagon socket head cap bolt with low head: 6×M5×10

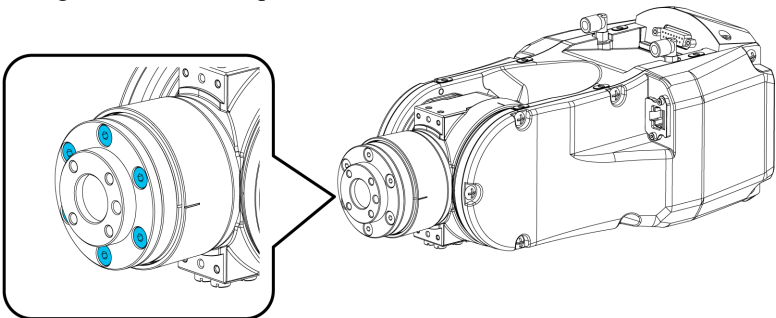

4.6.4 Variable Mechanical Stop

This option is used to mechanically limit the motion range of the Manipulator.

For installation and angle restriction measures, refer to the following section.

Setting the Work Envelope by Mechanical Stops

Variable Mechanical Stop (J1)

Parts Included	Qty.
Variable Mechanical Stop (J1)	1
Hexagon socket head cap bolt M12×30	2

Variable Mechanical Stop (J2)

Parts Included	Qty.
Variable Mechanical Stop (J2)	1
Hexagon socket head cap bolt M10×35	2

Variable Mechanical Stop (J3)

Parts Included	Qty.
Variable Mechanical Stop (J3)	1
Hexagon socket head cap bolt M6×15	2

4.6.5 User Wires and Pneumatic Tubes

Use the following options when using the internal wiring and tubing for the hand drive.

Attached as standard. The parts can be purchased additionally in case of lost or shortage.

Fitting for Customer Use (ø6 Straight)

Parts Included	Qty.	Manufacturer	Type
ø6 straight fitting	2	SMC	KQ2S06-M6N

Fitting for Customer Use (ø6 Elbow)

Parts Included	Qty.	Manufacturer	Type
ø6 elbow fitting	2	SMC	KQ2L06-M6N

Standard User Connector Kit (D-sub)

Parts Included	Qty.	Manufacturer	Type
Connector	2	JAE	DA-15PF-N (Solder type)
Clamp hood	2	HRS	HDA-CTH (4-40) (10) (Connector setscrew: #4-40 UNC)

5. Periodic Inspection

Accurate inspection work is necessary to prevent breakdowns and ensure safety. This section explains the inspection schedule and what should be inspected.

Perform inspections according to the predetermined schedule.

5.1 C4 Manipulator Periodic Inspection

Accurate inspection work is necessary to prevent breakdowns and ensure safety. This section explains the inspection schedule and what should be inspected.

Perform inspections according to the predetermined schedule.

5.1.1 Inspection

5.1.1.1 Inspection Schedule

Inspection items are divided into five stages (daily, 1-month, 3-month, 6-month, and 12-month), with additional items added at each stage. However, if the Manipulator is powered and operated for more than 250 hours in a month, add inspection items every 250, 750, 1500, and 3000 hours.

	Inspection Item					
	Daily Inspection	1-month Inspection	3-month Inspection	6-month Inspection	12-month Inspection	Overhaul (Parts Replacement)
1 months (250 hours)	Perform daily	✓				
2 months (500 hours)		✓				
3 months (750 hours)		✓	✓			
4 months (1,000 hours)		✓				
5 months (1,250 hours)		✓				
6 months (1,500 hours)		✓	✓	✓		
7 months (1,750 hours)		✓				
8 months (2,000 hours)		✓				
9 months (2,250 hours)		✓	✓			
10 months (2,500 hours)		✓				
11 months (2,750 hours)		✓				
12 months (3,000 hours)		✓	✓	✓	✓	
13 months (3,250 hours)		✓				
⋮	⋮	⋮	⋮	⋮	⋮	⋮

	Inspection Item					
	Daily Inspection	1-month Inspection	3-month Inspection	6-month Inspection	12-month Inspection	Overhaul (Parts Replacement)
(20,000 hours)						✓

5.1.1.2 Inspection Details

Inspection items

Inspection Item	Inspection Location	Daily Inspection	1-month Inspection	3-month Inspection	6-month Inspection	12-month Inspection
Check for loose or rattling bolts	Hand mounting bolts	✓	✓	✓	✓	✓
	Manipulator installation bolts	✓	✓	✓	✓	✓
Check for loose connectors	Manipulator side external (connector plate, etc.)	✓	✓	✓	✓	✓
Inspect for flaws: Clean off adhering debris, etc.	Entire Manipulator	✓	✓	✓	✓	✓
	External cables		✓	✓	✓	✓
Correct deformations and misalignments	Safety barriers, etc.	✓	✓	✓	✓	✓
Check either the external short connector or the brake release unit connector is connected	The external short connector on the back side of the Manipulator, or the brake release unit connector	✓	✓	✓	✓	✓
Check brake operation	Brake for Joint #1 to #6	✓	✓	✓	✓	✓
Check for abnormal operation noise and vibration	Entire Manipulator	✓	✓	✓	✓	✓

Inspection methods

Inspection Item	Inspection Method
Check for loose or rattling bolts	Using an Allen wrench or similar tool, check that the hand mounting bolts and Manipulator installation bolts are not loose. If the bolts are loose, refer to the following section, and retighten to the proper torque. Tightening the Hexagon Socket Head Cap Bolts
Check for loose connectors	Check that no connectors are loose. If a connector is loose, reattach it so that it will not come off.
Inspect for flaws: Clean off adhering debris, etc.	Check the appearance of the Manipulator, and clean off any dust or other foreign substances adhering to it. Check the appearance of the cables for any flaws, and make sure it is not disconnected.

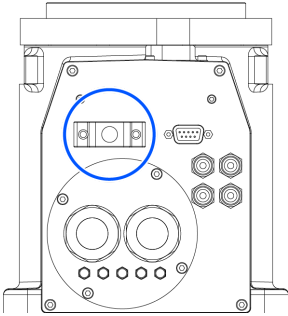
Inspection Item	Inspection Method
Correct deformations and misalignments	Check for misalignment of safety barriers and other components. If it is misaligned, correct it to the original position.
Check either the external short connector or the brake release unit connector is connected	<p>Check either the external short connector or the brake release unit connector is connected. When it is not connected, connect it.</p> 
Check brake operation	With the motor turned off, check that the arm does not drop. If the arm drops while the motor is turned off and the brake is not released, contact the supplier.
Check for abnormal operation noise and vibration	Check for any abnormal noises and vibrations during operation. If you notice anything unusual, contact the supplier.

5.1.2 Overhaul (Parts Replacement)

Overhaul (replacement) shall be performed by properly trained service engineers.

For details, refer to the following manual.

"Safety Manual - Role and Training for Safety Managers"

5.1.3 Applying Grease

The reduction gear units and the bevel gear need greasing regularly.

⚠ CAUTION

- Be careful that the grease does not run out. When grease runs out, scratches and other defects can occur on the slide, not only hindering maximum performance, but also requiring significant time and money to repair.
- If grease enters the eyes or mouth or adheres to the skin, take the following measures:
 - If it enters the eyes
After rinsing the eyes thoroughly with clean water, seek medical attention.
 - If it enters the mouth
If swallowed, do not force vomiting, and seek medical attention. If the mouth is contaminated, rinse thoroughly with water.
 - If adhered to skin
Rinse with water and soap.

	Part	Interval	Safety Information
All joints	Reduction gear	When overhaul is performed	Applying grease can only be performed by properly trained service engineers. For more information, please contact the supplier.
Joint #6	Bevel gear		

5.1.4 Tightening the Hexagon Socket Head Cap Bolts

Hexagon socket head cap bolts (referred to as "bolts" below) are used in locations where mechanical strength is required. During assembly, these bolts are tightened at the tightening torques shown in the following table.

Unless otherwise specified, when retightening these bolts in the work procedures described in this manual, use a torque wrench or similar tool to obtain the tightening torques in the following table.

Bolt	Tightening Torque
M3	2.0 ± 0.1 N·m (21 ± 1 kgf·cm)
M4	4.0 ± 0.2 N·m (41 ± 2 kgf·cm)
M5	8.0 ± 0.4 N·m (82 ± 4 kgf·cm)
M6	13.0 ± 0.6 N·m (133 ± 6 kgf·cm)
M8	32.0 ± 1.6 N·m (326 ± 16 kgf·cm)
M10	58.0 ± 2.9 N·m (590 ± 30 kgf·cm)
M12	100.0 ± 5.0 N·m (1,020 ± 51 kgf·cm)

For set screw, refer to the following table.

Set Screw	Tightening Torque
M4	2.4 ± 0.1 N·m (26 ± 1 kgf·cm)
M5	3.9 ± 0.2 N·m (40 ± 2 kgf·cm)

It is recommended that bolts arranged in a circular pattern be secured in place by tightening in criss-cross order as shown in the figure.

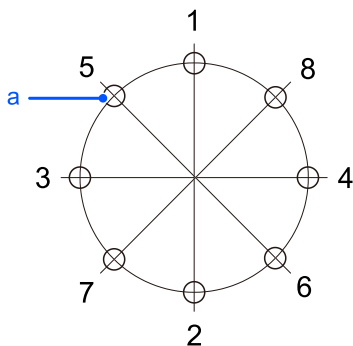

Symbol	Description
a	Threaded holes

When securing the bolts, do not tighten the bolts all at once, but tighten them in two or three separate rounds with an Allen wrench, and then use a torque wrench or similar tool to secure them at the tightening torques shown in the table above.

5.2 C8 Manipulator Periodic Inspection

Accurate inspection work is necessary to prevent breakdowns and ensure safety. This section explains the inspection schedule and what should be inspected.

Perform inspections according to the predetermined schedule.

5.2.1 Inspection

5.2.1.1 Inspection Schedule

Inspection items are divided into five stages (daily, 1-month, 3-month, 6-month, and 12-month), with additional items added at each stage. However, if the Manipulator is powered and operated for more than 250 hours in a month, add inspection items every 250, 750, 1500, and 3000 hours.

	Inspection Item					
	Daily Inspection	1-month Inspection	3-month Inspection	6-month Inspection	12-month Inspection	Overhaul (Parts Replacement)
1 months (250 hours)	Perform daily	✓				
2 months (500 hours)		✓				
3 months (750 hours)		✓	✓			
4 months (1,000 hours)		✓				
5 months (1,250 hours)		✓				
6 months (1,500 hours)		✓	✓	✓		
7 months (1,750 hours)		✓				
8 months (2,000 hours)		✓				
9 months (2,250 hours)		✓	✓			
10 months (2,500 hours)		✓				
11 months (2,750 hours)		✓				
12 months (3,000 hours)		✓	✓	✓	✓	
13 months (3,250 hours)		✓				

	Inspection Item					
	Daily Inspection	1-month Inspection	3-month Inspection	6-month Inspection	12-month Inspection	Overhaul (Parts Replacement)
∴	∴	∴	∴	∴	∴	∴
(20,000 hours)						✓

5.2.1.2 Inspection Details

Inspection items

Inspection Item	Inspection Location	Daily Inspection	1-month Inspection	3-month Inspection	6-month Inspection	12-month Inspection
Check for loose or rattling bolts	Hand mounting bolts	✓	✓	✓	✓	✓
	Manipulator installation bolts	✓	✓	✓	✓	✓
Check for loose connectors	Manipulator side external (connector plate, etc.)	✓	✓	✓	✓	✓
Inspect for flaws: Clean off adhering debris, etc.	Entire Manipulator	✓	✓	✓	✓	✓
	External cables		✓	✓	✓	✓
Correct deformations and misalignments	Safety barriers, etc.	✓	✓	✓	✓	✓
Check either the external short connector or the brake release unit connector is connected	The external short connector on the back side of the Manipulator, or the brake release unit connector	✓	✓	✓	✓	✓
Check brake operation	Brake for Joint #1 to #6	✓	✓	✓	✓	✓
Check for abnormal operation noise and vibration	Entire Manipulator	✓	✓	✓	✓	✓
Check that fan is working (only for C8-B1401*** (C8XL)).	Fan	✓	✓	✓	✓	✓

Inspection methods

Inspection Item	Inspection Method
Check for loose or rattling bolts	Using an Allen wrench or similar tool, check that the hand mounting bolts and Manipulator installation bolts are not loose. If the bolts are loose, refer to the following section, and retighten to the proper torque. Tightening the Hexagon Socket Head Cap Bolts
Check for loose connectors	Check that no connectors are loose. If a connector is loose, reattach it so that it will not come off.

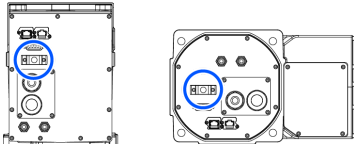
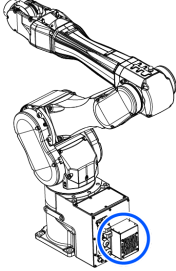
Inspection Item	Inspection Method
Inspect for flaws: Clean off adhering debris, etc.	Check the appearance of the Manipulator, and clean off any dust or other foreign substances adhering to it. Check the appearance of the cables for any flaws, and make sure it is not disconnected.
Correct deformations and misalignments	Check for misalignment of safety barriers and other components. If it is misaligned, correct it to the original position.
Check either the external short connector or the brake release unit connector is connected	Check either the external short connector or the brake release unit connector is connected. When it is not connected, connect it. 
Check brake operation	With the motor turned off, check that the arm does not drop. If the arm drops while the motor is turned off and the brake is not released, contact the supplier.
Check for abnormal operation noise and vibration	Check for any abnormal noises and vibrations during operation. If you notice anything unusual, contact the supplier.
Check that fan is working (only for C8-B1401*** (C8XL)).	With the motor turned on, check that the fan is working. If the fan does not work while the motor is turned on, contact the supplier. 

5.2.2 Overhaul (Parts Replacement)

Overhaul (replacement) shall be performed by properly trained service engineers.

For details, refer to the following manual.

"Safety Manual - Role and Training for Safety Managers"

5.2.3 Applying Grease

The reduction gear units and the bevel gear need greasing regularly.

⚠ CAUTION

- Be careful that the grease does not run out. When grease runs out, scratches and other defects can occur on the slide, not only hindering maximum performance, but also requiring significant time and money to repair.
- If grease enters the eyes or mouth or adheres to the skin, take the following measures:
 - If it enters the eyes
After rinsing the eyes thoroughly with clean water, seek medical attention.
 - If it enters the mouth
If swallowed, do not force vomiting, and seek medical attention. If the mouth is contaminated, rinse thoroughly with water.
 - If adhered to skin
Rinse with water and soap.

	Part	Interval	Safety Information
All joints	Reduction gear	When overhaul is performed	Applying grease can only be performed by properly trained service engineers. For more information, please contact the supplier.
Joint #6	Bevel gear		

5.2.4 Tightening the Hexagon Socket Head Cap Bolts

Hexagon socket head cap bolts (referred to as "bolts" below) are used in locations where mechanical strength is required. During assembly, these bolts are tightened at the tightening torques shown in the following table.

Unless otherwise specified, when retightening these bolts in the work procedures described in this manual, use a torque wrench or similar tool to obtain the tightening torques in the following table.

Bolt	Tightening Torque
M3	2.0 ± 0.1 N·m (21 ± 1 kgf·cm)
M4	4.0 ± 0.2 N·m (41 ± 2 kgf·cm)
M5	8.0 ± 0.4 N·m (82 ± 4 kgf·cm)
M6	13.0 ± 0.6 N·m (133 ± 6 kgf·cm)
M8	32.0 ± 1.6 N·m (326 ± 16 kgf·cm)
M10	58.0 ± 2.9 N·m (590 ± 30 kgf·cm)
M12	100.0 ± 5.0 N·m (1,020 ± 51 kgf·cm)

For set screw, refer to the following table.

Set Screw	Tightening Torque
M4	2.4 ± 0.1 N·m (26 ± 1 kgf·cm)

Set Screw	Tightening Torque
M5	$3.9 \pm 0.2 \text{ N}\cdot\text{m}$ ($40 \pm 2 \text{ kgf}\cdot\text{cm}$)
M6	$8.0 \pm 0.4 \text{ N}\cdot\text{m}$ ($82 \pm 4 \text{ kgf}\cdot\text{cm}$)

It is recommended that bolts arranged in a circular pattern be secured in place by tightening in criss-cross order as shown in the figure.

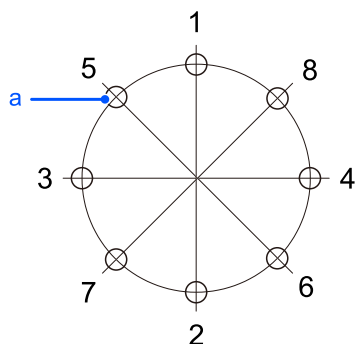

Symbol	Description
a	Threaded holes

When securing the bolts, do not tighten the bolts all at once, but tighten them in two or three separate rounds with an Allen wrench, and then use a torque wrench or similar tool to secure them at the tightening torques shown in the table above.

5.3 C12 Manipulator Periodic Inspection

Accurate inspection work is necessary to prevent breakdowns and ensure safety. This section explains the inspection schedule and what should be inspected.

Perform inspections according to the predetermined schedule.

5.3.1 Inspection

5.3.1.1 Inspection Schedule

Inspection items are divided into five stages (daily, 1-month, 3-month, 6-month, and 12-month), with additional items added at each stage. However, if the Manipulator is powered and operated for more than 250 hours in a month, add inspection items every 250, 750, 1500, and 3000 hours.

	Inspection Item					
	Daily Inspection	1-month Inspection	3-month Inspection	6-month Inspection	12-month Inspection	Overhaul (Parts Replacement)
1 months (250 hours)	Perform daily	✓				
2 months (500 hours)		✓				
3 months (750 hours)		✓	✓			
4 months (1,000 hours)		✓				
5 months (1,250 hours)		✓				
6 months (1,500 hours)		✓	✓	✓		
7 months (1,750 hours)		✓				
8 months (2,000 hours)		✓				
9 months (2,250 hours)		✓	✓			
10 months (2,500 hours)		✓				
11 months (2,750 hours)		✓				
12 months (3,000 hours)		✓	✓	✓	✓	
13 months (3,250 hours)		✓				
⋮		⋮	⋮	⋮	⋮	⋮
(20,000 hours)					✓	

5.3.1.2 Inspection Details

Inspection items

Inspection Item	Inspection Location	Daily Inspection	1-month Inspection	3-month Inspection	6-month Inspection	12-month Inspection
Check for loose or rattling bolts	Hand mounting bolts	✓	✓	✓	✓	✓
	Manipulator installation bolts	✓	✓	✓	✓	✓
Check for loose connectors	Manipulator side external (connector plate, etc.)	✓	✓	✓	✓	✓

Inspection Item	Inspection Location	Daily Inspection	1-month Inspection	3-month Inspection	6-month Inspection	12-month Inspection
Inspect for flaws: Clean off adhering debris, etc.	Entire Manipulator	✓	✓	✓	✓	✓
	External cables		✓	✓	✓	✓
Correct deformations and misalignments	Safety barriers, etc.	✓	✓	✓	✓	✓
Check either the external short connector or the brake release unit connector is connected	The external short connector on the back side of the Manipulator, or the brake release unit connector	✓	✓	✓	✓	✓
Check brake operation	Brake for Joint #1 to #6	✓	✓	✓	✓	✓
Check for abnormal operation noise and vibration	Entire Manipulator	✓	✓	✓	✓	✓
Check that fan is working.	Fan	✓	✓	✓	✓	✓

Inspection methods

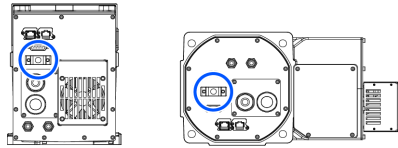
Inspection Item	Inspection Method
Check for loose or rattling bolts	Using an Allen wrench or similar tool, check that the hand mounting bolts and Manipulator installation bolts are not loose. If the bolts are loose, refer to the following section, and retighten to the proper torque. Tightening the Hexagon Socket Head Cap Bolts
Check for loose connectors	Check that no connectors are loose. If a connector is loose, reattach it so that it will not come off.
Inspect for flaws: Clean off adhering debris, etc.	Check the appearance of the Manipulator, and clean off any dust or other foreign substances adhering to it. Check the appearance of the cables for any flaws, and make sure it is not disconnected.
Correct deformations and misalignments	Check for misalignment of safety barriers and other components. If it is misaligned, correct it to the original position.
Check either the external short connector or the brake release unit connector is connected	Check either the external short connector or the brake release unit connector is connected. When it is not connected, connect it. 
Check brake operation	With the motor turned off, check that the arm does not drop. If the arm drops while the motor is turned off and the brake is not released, contact the supplier.

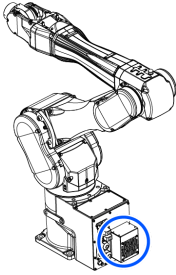
Inspection Item	Inspection Method
Check for abnormal operation noise and vibration	Check for any abnormal noises and vibrations during operation. If you notice anything unusual, contact the supplier.
Check that fan is working.	<p>With the motor turned on, check that the fan is working. If the fan does not work while the motor is turned on, contact the supplier.</p> 

5.3.2 Overhaul (Parts Replacement)

Overhaul (replacement) shall be performed by properly trained service engineers.

For details, refer to the following manual.
"Safety Manual - Role and Training for Safety Managers"

5.3.3 Applying Grease

The reduction gear units and the bevel gear need greasing regularly.

⚠ CAUTION

- Be careful that the grease does not run out. When grease runs out, scratches and other defects can occur on the slide, not only hindering maximum performance, but also requiring significant time and money to repair.
- If grease enters the eyes or mouth or adheres to the skin, take the following measures:
 - If it enters the eyes
After rinsing the eyes thoroughly with clean water, seek medical attention.
 - If it enters the mouth
If swallowed, do not force vomiting, and seek medical attention. If the mouth is contaminated, rinse thoroughly with water.
 - If adhered to skin
Rinse with water and soap.

	Part	Interval	Safety Information
All joints	Reduction gear	When overhaul is performed	Applying grease can only be performed by properly trained service engineers. For more information, please contact the supplier.
Joint #6	Bevel gear		

5.3.4 Tightening the Hexagon Socket Head Cap Bolts

Hexagon socket head cap bolts (referred to as "bolts" below) are used in locations where mechanical strength is required. During assembly, these bolts are tightened at the tightening torques shown in the following table.

Unless otherwise specified, when retightening these bolts in the work procedures described in this manual, use a torque wrench or similar tool to obtain the tightening torques in the following table.

Bolt	Tightening Torque
M3	2.0 ± 0.1 N·m (21 ± 1 kgf·cm)
M4	4.0 ± 0.2 N·m (41 ± 2 kgf·cm)
M5	8.0 ± 0.4 N·m (82 ± 4 kgf·cm)
M6	13.0 ± 0.6 N·m (133 ± 6 kgf·cm)
M8	32.0 ± 1.6 N·m (326 ± 16 kgf·cm)
M10	58.0 ± 2.9 N·m (590 ± 30 kgf·cm)
M12	100.0 ± 5.0 N·m (1,020 ± 51 kgf·cm)

For set screw, refer to the following table.

Set Screw	Tightening Torque
M4	2.4 ± 0.1 N·m (26 ± 1 kgf·cm)
M5	3.9 ± 0.2 N·m (40 ± 2 kgf·cm)
M6	8.0 ± 0.4 N·m (82 ± 4 kgf·cm)

It is recommended that bolts arranged in a circular pattern be secured in place by tightening in criss-cross order as shown in the figure.

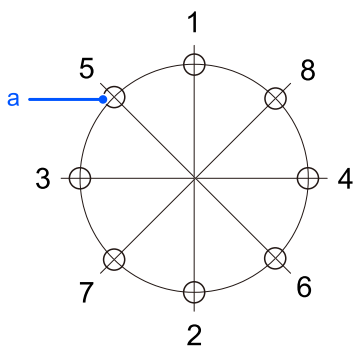

Symbol	Description
a	Threaded holes

When securing the bolts, do not tighten the bolts all at once, but tighten them in two or three separate rounds with an Allen wrench, and then use a torque wrench or similar tool to secure them at the tightening torques shown in the table above.

6. Appendix

This section provides detailed technical data such as the specifications, stopping time, and stopping distance for each model.

6.1 Appendix A: Specifications Table

6.1.1 C4 Specifications

Item		Specifications	
		C4-B601 **	C4-B901**
Machinery name		Industrial robot	
Product series		C-B	
Model		C4-B601 ** Model Number	C4-B901** Model Number
Model Name		C4	C4L
Mounting type		Table top mounting (Ceiling mounting) *1	
Arm length	P point: J1 to J5 center	600.0	900.0
Maximum reach	J1 to J6 flange	665.0	965.0
Manipulator weight (not include the weight of cables or shipping jigs)		27 kg: 59.5 lb	30 kg: 66.1 lb
Drive system	All joints	AC servo motor	
Maximum operating speed *2	Joint #1	450°/s	275°/s
	Joint #2	450°/s	275°/s
	Joint #3	514°/s	289°/s
	Joint #4	555°/s	
	Joint #5	555°/s	
	Joint #6	720°/s	
Maximum synthetic speed		9459 mm/s	8495 mm/s
Repeatability	Joint #1 to #6	±0.02 mm	±0.03 mm
Maximum motion range	Joint #1	±170°	±170°
		±180° without the mechanical stop	
	Joint #2	-160 to +65°	
	Joint #3	-51 to +225°	
	Joint #4	±200°	
	Joint #5	±135°	
Joint #6	±540°		

Item		Specifications	
		C4-B601 **	C4-B901**
Max. pulse range (pulse)	Joint #1	±4951609	±8102633
		Software limit maximum value ±5242880	Software limit maximum value ±8579259
	Joint #2	-4660338 to +1893263	-7626008 to +3098066
	Joint #3	-1299798 to +5734400	-2310751 to +10194489
	Joint #4	±4723316	
	Joint #5	±3188238	
	Joint #6	±9830400	
Resolution	Joint #1	0.0000343°/pulse	0.0000210°/pulse
	Joint #2	0.0000343°/pulse	0.0000210°/pulse
	Joint #3	0.0000392°/pulse	0.0000221°/pulse
	Joint #4	0.0000423°/pulse	
	Joint #5	0.0000423°/pulse	
	Joint #6	0.0000549°/pulse	
Motor rated capacity	Joint #1	400 W	
	Joint #2	400 W	
	Joint #3	150 W	
	Joint #4	50 W	
	Joint #5	50 W	
	Joint #6	50 W	
Payload (load) *3	Rated	1 kg	
	Maximum	4 kg (5 kg with arm downward positioning)	
Allowable moment	Joint #4	4.41 N·m (0.45 kgf·m)	
	Joint #5	4.41 N·m (0.45 kgf·m)	
	Joint #6	2.94 N·m (0.3 kgf·m)	
Allowable moment of inertia *4 (GD ² /4)	Joint #4	0.15 kg·m ²	
	Joint #5	0.15 kg·m ²	
	Joint #6	0.10 kg·m ²	
User wires		9 wires (D-sub)	

Item		Specifications	
		C4-B601 **	C4-B901**
User wires *5		ø4 mm pneumatic tube × 4 Pressure resistance: 0.59 MPa (6 kgf/cm ²) (86 psi)	
Environmental requirements *6	Ambient temperature	5 to 40°C *7	
	Ambient relative humidity	10 to 80% RH (no condensation)	
	Vibration	4.9 m/s ² (0.5 G) or less	
Transportation and storage	Temperature	-20 to +60°C	
	Humidity	10 to 90% (no condensation)	
Noise level *8		LAeq = 77.4 dB (A)	LAeq = 73.3 dB (A) or lower
Environmental specifications *9		Standard, Cleanroom & ESD	
Compatible Controller		RC700-E	
M/C cable	Cable weight (cable only)	For fixing and signal (common to all lengths)	0.06 kg/m
		For fixing and power (common to all lengths)	0.45 kg/m
		For movable and signal (common to all lengths)	0.07 kg/m
		For movable and power (common to all lengths)	0.52 kg/m
	Cable outer diameter	For fixing and signal (common to all lengths)	ø6.2 mm (typ)
		For fixing and power (common to all lengths)	ø17.8 mm (typ)
		For movable and signal (common to all lengths)	ø6.4 mm (typ)
		For movable and power (common to all lengths)	ø17.8 mm (typ)
	Minimum bending radius *10	For fixing and signal (common to all lengths)	38 mm
		For fixing and power (common to all lengths)	107 mm
		For movable and signal (common to all lengths)	100 mm
		For movable and power (common to all lengths)	100 mm

Item		Specifications	
		C4-B601 **	C4-B901**
Default values (Max. setting values)	Speed	5 (100)	
	Accel *11	5, 5 (120, 120)	
	SpeedS	50 (2000)	
	AccelS	200 (25000)	200 (15000) *12
	Fine	10000, 10000, 10000, 10000, 10000, 10000 (65535, 65535, 65535, 65535, 65535, 65535)	
	Weight	1 (5)	

*1: Manipulators are set to "Table Top mounting" at shipment. To use the Manipulators as "Ceiling mounting", you need to change the model settings. For details on how to change the model settings, refer to the following sections.

- [Changing the Robot](#)
- "Epson RC+ User's Guide - Robot Configuration"

*2: When PTP statements are used

*3: If the payload exceeds the maximum payload, refer to the following section.

["WEIGHT Setting - Restrictions on payload exceeding the maximum payload"](#)

*4: If the center of gravity is at the center of each arm.

If the center of gravity is not at the center of each arm, set the eccentricity using INERTIA command.

*5: For details of the installed pneumatic tube for customer use, refer to the following section.

[User Wires and Pneumatic Tubes](#)

*6: For details of the environmental requirements, refer to the following section.

[Environment](#)

*7: When used in a low-temperature environment near the minimum temperature specified in the product specifications, or when the unit is idle for a long period of time during holidays or at night, a collision detection error or similar error may occur immediately after the start of operation due to high resistance in the drive unit. In such cases, warm-up operation for about 10 minutes is recommended.

*8: The conditions at measurement are as follows.

- Operating conditions: Under rated load, all arms simultaneous motion, maximum speed, maximum acceleration/deceleration, and maximum acceleration/deceleration which duty is 100%.
- Measurement point: 1000 mm apart from the rear of Manipulator

*9: Manipulators with cleanroom specifications discharge the exhaust inside of the base and inside of the arm cover section together. Consequently, if there is a gap in the base section, the arm tip section will not be sufficiently negatively pressurized, which may result in dust generation.

- Cleanliness: Class ISO 3 (ISO 14644-1)

- Exhaust port: Fitting for ø8 mm tube 60 L/min vacuum

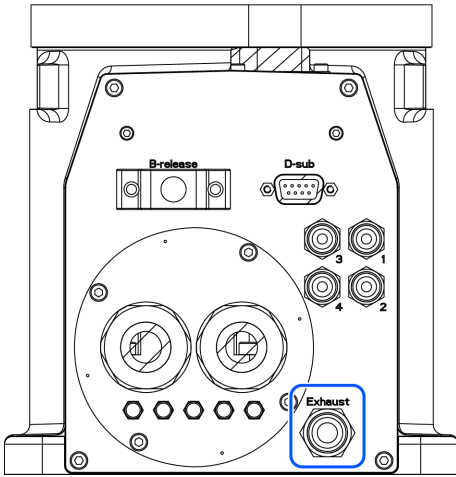

- Exhaust tube: Polyurethane tube Outer diameter: ø8 mm (Inner diameter: ø5 to 6 mm)

ESD specification uses resin materials with anti-static treatment. This model controls adhesion of dust due to electrification.

Protection level for the standard model and cleanroom model Manipulators is equivalent to IP20.

The IP (International Protection) rating is an international standard indicating the degree of protection against dust and water.

Protection Class		
IP20	Dust protection level: 2	A solid object which is 12.5 mm or longer cannot touch dangerous areas inside of the Manipulator.
	Water protection level: 0	Not protected.

*10: Note the following points when wiring the movable M/C cable.

- Install the cable not to apply a load to the connector.
- Bend the cable at the minimum bending radius of the movable part or more. The bending radius (a) and dimensions are shown in the figure below.

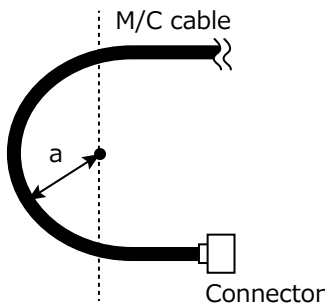

*11: The Accel setting of "100" is the optimum setting that balances acceleration/deceleration and vibration during positioning. Although values larger than 100 can be set to Accel, it is recommended to minimize the use of large values to necessary motions since operating the Manipulator continuously with the large Accel setting may shorten the product life remarkably.

*12: Maximum AccelS setting value for payload of 4 kg or more is 12000.

Although setting the value exceeding 12000 does not cause an error, do not set the value in order to prevent Manipulator malfunction.

6.1.2 C8 Specifications

Item		Specifications	
		C8-B901 ***	C8-B1401***
Machinery name		Industrial robot	
Product series		C-B	
Model		C8-B901 *** Model Number	C8-B1401*** Model Number
Model Name		C8L	C8XL
Mounting type *1		Table top mounting, Ceiling mounting, Wall mounting	
Arm length	P point: J1 to J5 center	901.1	1400.6
Maximum reach	J1 to J6 flange	981.1	1480.6
Manipulator weight (not include the weight of cables or shipping jigs)	Standard, cleanroom & ESD specifications	53 kg: 117 lb	63 kg: 139 lb
	Protected-Model	57 kg: 126 lb	66 kg: 146 lb
Drive system	All joints	AC servo motor	
Maximum operating speed *2	Joint #1	294°/s	200°/s
	Joint #2	300°/s	167°/s
	Joint #3	360°/s	200°/s
	Joint #4	480°/s	
	Joint #5	450°/s	
	Joint #6	720°/s	
Maximum synthetic speed		9679 mm/s	8858 mm/s
Repeatability	Joint #1 to #6	±0.03 mm	±0.05 mm
Maximum motion range	Joint #1	±240°	
	Joint #2	-158° to +65°	-135° to +55°
	Joint #3	-61° to +202°	
	Joint #4	±200°	
	Joint #5	±135°	
	Joint #6	±540°	
Max. pulse range (pulse)	Joint #1	±10695600	±15736800
	Joint #2	-6903178 to +2839915	-10616940 to +4325420
	Joint #3	-2220949 to +7354618	-3997696 to +13238272
	Joint #4	±5461400	

Item		Specifications	
		C8-B901 ***	C8-B1401***
	Joint #5	±3932280	
	Joint #6	±9830400	
Resolution	Joint #1	0.0000224°/pulse	0.0000153°/pulse
	Joint #2	0.0000229°/pulse	0.0000127°/pulse
	Joint #3	0.0000275°/pulse	0.0000153°/pulse
	Joint #4	0.0000366°/pulse	
	Joint #5	0.0000343°/pulse	
	Joint #6	0.0000549°/pulse	
Motor rated capacity	Joint #1	1000 W	
	Joint #2	750 W	
	Joint #3	400 W	
	Joint #4	100 W	
	Joint #5	100 W	
	Joint #6	100 W	
Payload (load) *3	Rated	3 kg	
	Maximum	8 kg	
Allowable moment	Joint #4	16.6 N·m (1.69 kgf·m)	
	Joint #5	16.6 N·m (1.69 kgf·m)	
	Joint #6	9.4 N·m (0.96 kgf·m)	
Allowable moment of inertia *4 (GD ² /4)	Joint #4	0.47 kg·m ²	
	Joint #5	0.47 kg·m ²	
	Joint #6	0.15 kg·m ²	
User wires	15 wires (D-sub) 8 pin (RJ45) equivalent to Cat.5e 6 pin (for Force Sensor)		
User wires *5	ø6 mm pneumatic tube × 2 Pressure resistance: 0.59 MPa (6 kgf/cm ²) (86 psi)		
Environmental requirements *6	Ambient temperature	5 to 40°C *7	
	Ambient relative humidity	10 to 80% RH (no condensation)	
	Vibration	4.9 m/s ² (0.5 G) or less	
Transportation and storage	Temperature	-20 to +60°C	

Item		Specifications		
		C8-B901 ***	C8-B1401***	
	Humidity	10 to 90% (no condensation)		
Noise level *8		LAeq = 74.9 dB (A) or lower	LAeq = 78 dB (A) or lower	
Environmental Specifications		Standard *9 Cleanroom & ESD *9 Protection (IP67) *10		
Compatible Controller		RC700-E		
M/C cable	Cable weight (cable only)	For fixing and signal (common to all lengths)	0.06 kg/m	
		For fixing and power (common to all lengths)	0.45 kg/m	
		For movable and signal (common to all lengths)	0.07 kg/m	
		For movable and power (common to all lengths)	0.52 kg/m	
	Cable outer diameter	For fixing and signal (common to all lengths)	ø6.2 mm (typ)	
		For fixing and power (common to all lengths)	ø17.8 mm (typ)	
		For movable and signal (common to all lengths)	ø6.4 mm (typ)	
		For movable and power (common to all lengths)	ø17.8 mm (typ)	
	Minimum bending radius *11	For fixing and signal (common to all lengths)	38 mm	
		For fixing and power (common to all lengths)	107 mm	
		For movable and signal (common to all lengths)	100 mm	
		For movable and power (common to all lengths)	100 mm	
	Default values (Max. setting values)	Speed	3 (100)	
		Accel *12	5, 5 (120, 120)	
		SpeedS	50 (2000)	
		AccelS *13	200 (35000)	120 (25000)
Fine		10000, 10000, 10000, 10000, 10000, 10000 (131070, 131070, 131070, 131070, 131070, 131070)		

Item	Specifications	
	C8-B901 ***	C8-B1401***
Weight	3 (8)	
Inertia	0.03 (0.15)	

*1: Mounting types other than Table top mounting, Ceiling mounting, and Wall mounting are out of specification.

*2: When PTP statements are used

*3: Do not apply the load exceeding the maximum payload.

*4: If the center of gravity is at the center of each arm.

If the center of gravity is not at the center of each arm, set the eccentricity using INERTIA command.

*5: For details of the installed pneumatic tube for customer use, refer to the following section.

User Wires and Pneumatic Tubes

*6: For details of the environmental requirements, refer to the following section.

Environment

*7: When used in a low-temperature environment near the minimum temperature specified in the product specifications, or when the unit is idle for a long period of time during holidays or at night, a collision detection error or similar error may occur immediately after the start of operation due to high resistance in the drive unit. In such cases, warm-up operation for about 10 minutes is recommended.

*8: The conditions at measurement are as follows.

- Operating conditions: Under rated load, all arms simultaneous motion, maximum speed, and maximum acceleration/deceleration which duty is 100%.
- Measurement point: 1000 mm apart from the rear of Manipulator

*9: Manipulators with cleanroom specifications discharge the exhaust inside of the base and inside of the arm cover section together. Consequently, if there is a gap in the base section, the arm tip section will not be sufficiently negatively pressurized, which may result in dust generation.

- Cleanliness level:
 - C8L: ISO Class 3 (ISO14644-1)
 - C8XL: ISO Class 4 (ISO14644-1)

- Exhaust port: Fitting for $\varnothing 12$ mm tube 60 L/min vacuum

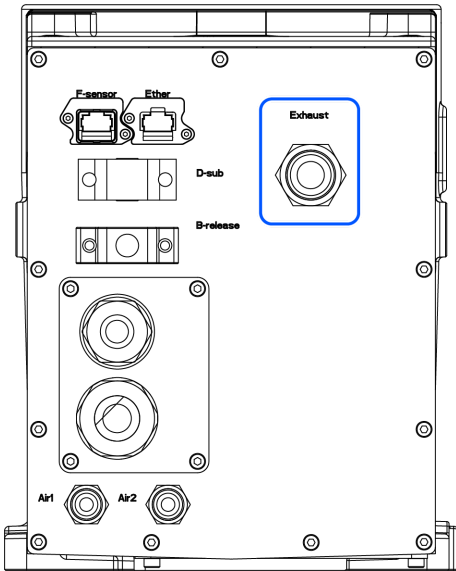

- Exhaust tube: Polyurethane tube Outer diameter: $\varnothing 12$ mm

ESD specification uses resin materials with anti-static treatment. This model controls adhesion of dust due to electrification.

Protection level for the standard model and cleanroom model Manipulators is equivalent to IP20.

The IP (International Protection) rating is an international standard indicating the degree of protection against dust and water.

Protection Class		
IP20	Dust protection level: 2	A solid object which is 12.5 mm or longer cannot touch dangerous areas inside of the Manipulator.
	Water protection level: 0	Not protected.

*10: Protection level for the protected-model Manipulators is IP67 (IEC standard). The Manipulators can be used in environments where the possibility of dust, water, and water-soluble cutting oil falling of the Manipulator exists. Note the following points.

- The Manipulator is not rust-proofed. Do not use the Manipulator in environment where corrosive liquids exist.
- Fluids that deteriorate the sealing materials, such as organic solvents, acids, alkalis, and chlorine cutting fluids, cannot be used.
- The Manipulator cannot be used for underwater operations.
- The Controller does not have protection features against the environment (Controller’s protection level: IP20). Make sure to install the system where environmental requirements for the Controller are satisfied.
- The fan cover is equivalent to IP 20.
- Be sure to connect a connector compliant with protection class IP67 or higher and a connector cover to the Ethernet cable connector.

The IP (International Protection) rating is an international standard indicating the degree of protection against dust and water.

Protection Class		
IP20	Dust protection level: 2	A solid object which is 12.5 mm or longer cannot touch dangerous areas inside of the Manipulator.

Protection Class		
	Water protection level: 0	Not protected.
IP67	Dust protection level: 6	A testing rod which is 1.0 mm or longer cannot touch dangerous areas inside of the Manipulator. Totally protected against dust.
	Water protection level: 7	Water cannot enter the Manipulator when the Manipulator is immersed in water for 30 minutes under the condition that the highest point of the Manipulator is located 0.15 m below the surface of the water and the lowest point is located 1 m below the surface of the water. (The Manipulator is stopped during the test.)

*11: Note the following points when wiring the movable M/C cable.

- Install the cable not to apply a load to the connector.
- Bend the cable at the minimum bending radius of the movable part or more. The bending radius (a) and dimensions are shown in the figure below.

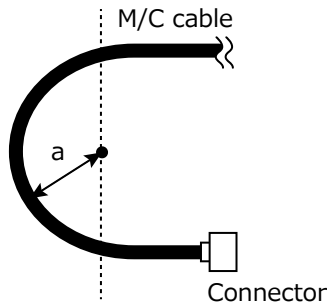

*12: The Accel setting of "100" is the optimum setting that balances acceleration/deceleration and vibration during positioning. Although values larger than 100 can be set to Accel, it is recommended to minimize the use of large values to necessary motions since operating the Manipulator continuously with the large Accel setting may shorten the product life remarkably.

*13: Maximum AccelS setting value varies depending on the load. For details, refer to the following figure. Setting the value which exceeds the maximum AccelS causes an error. Check the setting value.

Maximum AccelS setting value

- Table top mounting, Ceiling mounting

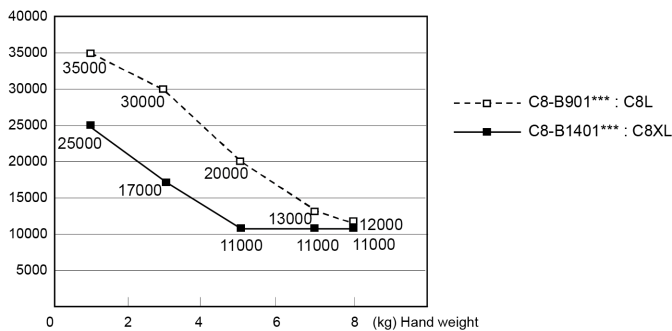

- Wall mounting

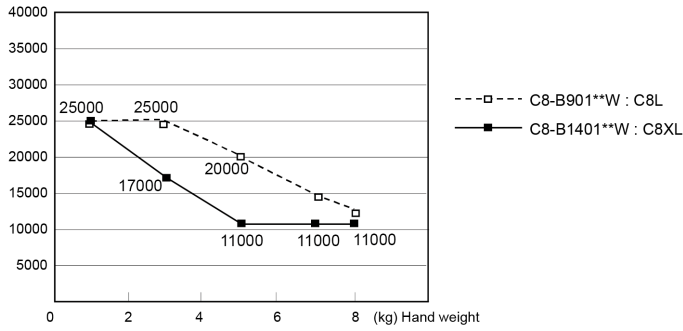

6.1.3 C12 Specifications

Item		Specifications
		C12-B1401**
Machinery name		Industrial robot
Product series		C-B
Model		C12-B1401** Model Number
Model Name		C12XL
Mounting type *1		Table top mounting
Arm length	P point: J1 to J5 center	1400.6
Maximum reach	J1 to J6 flange	1480.6
Manipulator weight (not include the weight of cables or shipping jigs)	Standard model Cleanroom & ESD model	63 kg: 139 lb
Drive system	All joints	AC servo motor
Maximum operating speed *2	Joint #1	200°/s
	Joint #2	167°/s
	Joint #3	200°/s
	Joint #4	300°/s
	Joint #5	360°/s
	Joint #6	720°/s
Maximum synthetic speed		8751 mm/s
Repeatability	Joint #1 to #6	±0.05 mm
Maximum motion range	Joint #1	±240°
	Joint #2	-135 to +55°
	Joint #3	-61 to +202°
	Joint #4	±200°
	Joint #5	±135°

Item		Specifications
		C12-B1401**
	Joint #6	±540°
Max. pulse range (pulse)	Joint #1	±15736800
	Joint #2	-10616940 to +4325420
	Joint #3	-3997696 to +13238272
	Joint #4	±8738240
	Joint #5	±4915350
	Joint #6	±9830400
Resolution	Joint #1	0.0000153°/pulse
	Joint #2	0.0000127°/pulse
	Joint #3	0.0000153°/pulse
	Joint #4	0.0000229°/pulse
	Joint #5	0.0000275°/pulse
	Joint #6	0.0000549°/pulse
Motor rated capacity	Joint #1	1000 W
	Joint #2	750 W
	Joint #3	400 W
	Joint #4	150 W
	Joint #5	150 W
	Joint #6	150 W
Payload (load) *3	Rated	3 kg
	Maximum	12 kg
Allowable moment	Joint #4	25.0 N·m (2.55 kgf·m)
	Joint #5	25.0 N·m (2.55 kgf·m)
	Joint #6	9.8 N·m (1.0 kgf·m)
Allowable moment of inertia *4 (GD ² /4)	Joint #4	0.70 kg·m ²
	Joint #5	0.70 kg·m ²
	Joint #6	0.20 kg·m ²
User wires		15 wires (D-sub) 8 pin (RJ45) equivalent to Cat.5e 6 pin (for Force Sensor)

Item		Specifications	
		C12-B1401**	
User wires *5		ø6 mm pneumatic tube × 2 Pressure resistance: 0.59 MPa (6 kgf/cm ²) (86 psi)	
Environmental requirements *6	Ambient temperature	5 to 40°C *7	
	Ambient relative humidity	10 to 80% RH (no condensation)	
	Vibration	4.9 m/s ² (0.5 G) or less	
Transportation and storage	Temperature	-20 to +60°C	
	Humidity	10 to 90% (no condensation)	
Noise level *8		LAeq = 79.6 dB (A) or lower	
Environmental specifications *9		Standard Cleanroom & ESD	
Compatible Controller		RC700-E	
M/C cable	Cable weight (cable only)	For fixing and signal (common to all lengths)	0.06 kg/m
		For fixing and power (common to all lengths)	0.45 kg/m
		For movable and signal (common to all lengths)	0.07 kg/m
		For movable and power (common to all lengths)	0.52 kg/m
	Cable outer diameter	For fixing and signal (common to all lengths)	ø6.2 mm (typ)
		For fixing and power (common to all lengths)	ø17.8 mm (typ)
		For movable and signal (common to all lengths)	ø6.4 mm (typ)
		For movable and power (common to all lengths)	ø17.8 mm (typ)
	Minimum bending radius *10	For fixing and signal (common to all lengths)	38 mm
		For fixing and power (common to all lengths)	107 mm
		For movable and signal (common to all lengths)	100 mm
		For movable and power (common to all lengths)	100 mm

Item		Specifications
		C12-B1401**
Default values (Max. setting values)	Speed	3 (100)
	Accel *11	5, 5 (120, 120)
	SpeedS	50 (2000)
	AccelS *12	120 (25000)
	Fine	10000, 10000, 10000, 10000, 10000, 10000 (131070, 131070, 131070, 131070, 131070, 131070)
	Weight	3 (12)
	Inertia	0.03 (0.2)

*1: Mounting types other than Table top mounting are out of specification.

*2: When PTP statements are used

*3: Do not apply the load exceeding the maximum payload.

*4: If the center of gravity is at the center of each arm.

If the center of gravity is not at the center of each arm, set the eccentricity using INERTIA command.

*5: For details of the installed pneumatic tube for customer use, refer to the following section.

User Wires and Pneumatic Tubes

*6: For details of the environmental requirements, refer to the following section.

Environment

*7: When used in a low-temperature environment near the minimum temperature specified in the product specifications, or when the unit is idle for a long period of time during holidays or at night, a collision detection error or similar error may occur immediately after the start of operation due to high resistance in the drive unit. In such cases, warm-up operation for about 10 minutes is recommended.

*8: The conditions at measurement are as follows.

- Operating conditions: Under rated load, all arms simultaneous motion, maximum speed, and maximum acceleration/deceleration which duty is 100%.
- Measurement point: 1000 mm apart from the rear of Manipulator

*9: Manipulators with cleanroom specifications discharge the exhaust inside of the base and inside of the arm cover section together. Consequently, if there is a gap in the base section, the arm tip section will not be sufficiently negatively pressurized, which may result in dust generation.

- Cleanliness: ISO Class 4 (ISO 14644-1)

- Exhaust port: Fitting for $\varnothing 12$ mm tube 60 L/min vacuum

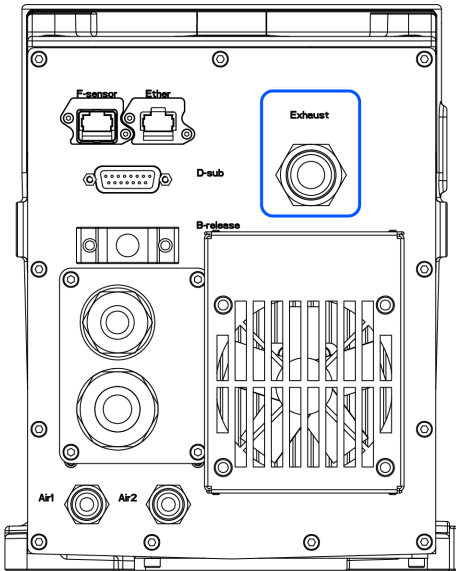

- Exhaust tube: Polyurethane tube Outer diameter: $\varnothing 12$ mm

ESD specification uses resin materials with anti-static treatment. This model controls adhesion of dust due to electrification.

Protection level for the standard model and cleanroom model Manipulators is equivalent to IP20.

The IP (International Protection) rating is an international standard indicating the degree of protection against dust and water.

Protection Class		
IP20	Dust protection level: 2	A solid object which is 12.5 mm or longer cannot touch dangerous areas inside of the Manipulator.
	Water protection level: 0	Not protected.

*10: Note the following points when wiring the movable M/C cable.

- Install the cable not to apply a load to the connector.
- Bend the cable at the minimum bending radius of the movable part or more. The bending radius (a) and dimensions are shown in the figure below.

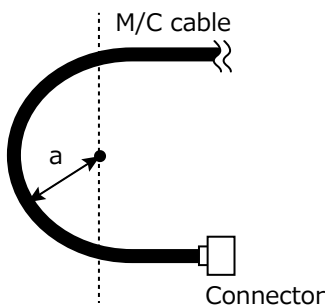

*11: The Accel setting of "100" is the optimum setting that balances acceleration/deceleration and vibration during positioning. Although values larger than 100 can be set to Accel, it is recommended to minimize the use of large values to necessary motions since operating the Manipulator continuously with the large Accel setting may shorten the product life remarkably.

*12: Maximum AccelS setting value varies depending on the load. For details, refer to the following figure. Setting the value which exceeds the maximum AccelS causes an error. Check the setting value.

Maximum AccelS setting value

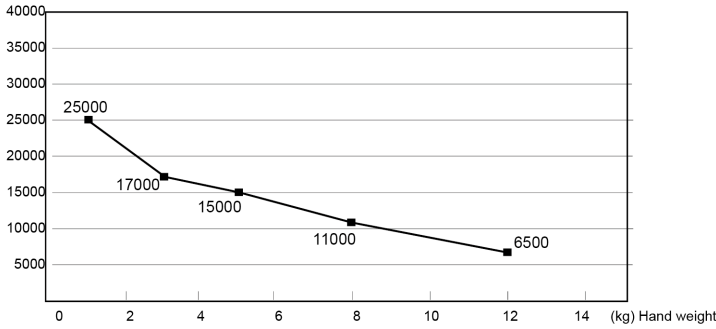

6.2 Appendix B: Stopping Time and Stopping Distance at Emergency Stop

The stopping time and stopping distance at an emergency stop are shown in the graphs for each model.

The stopping time is the length of time corresponding to the "Stopping time" in the figure below. Be sure to confirm that a safe environment is provided where the robot will be installed and operated.

For models equipped with a safety board such as RC700-E, the stopping time and stopping distance when using the Safety Limited Speed (SLS), Safety Limited Position (SLP), and Soft Axis Limiting are equivalent to those of the emergency stop.

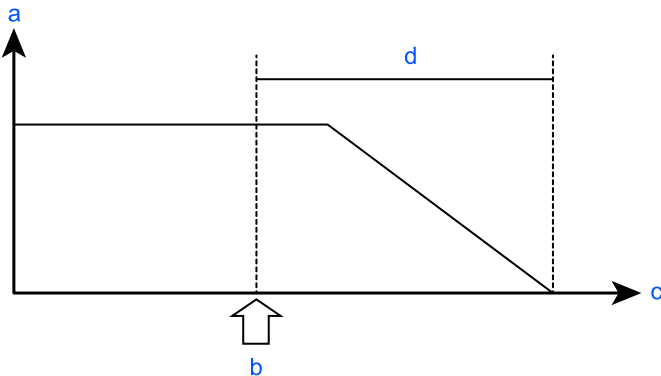

Symbol	Description
a	Motor speed
b	Emergency stop, Maximum Speed of SLS exceeded, monitoring areas and Joint Angle Limit of SLP exceeded, restricted range of Soft Axis Limiting exceeded
c	Time
d	Stopping time

Conditions:

The stopping time and stopping distance depend on the parameters (setting values) that were set for the robot. These graphs show the times and distances for the following parameters.

- Accel: 100, 100
- Other settings: Default

Explanation of legend:

The graphs are displayed for each Weight setting value (at 100%, approx. 66%, and approx. 33% of the maximum payload, and at the rated payload).

- Horizontal axis: Arm speed (Speed setting)
- Vertical axis: Stopping time and stopping distance at each arm speed
- Time (sec): Stopping time (sec)
- Distance (deg): stopping distance (degree)

When single failures are taken into account, the following adjustments are used.

- Stopping distance and angle: Each axis reaches the mechanical stop
- Stopping time: Add 500 ms

6.2.1 C4-B Stopping Time and Stopping Distance at Emergency Stop

C4-B601 **: J1 (Table top mounting, Ceiling mounting)

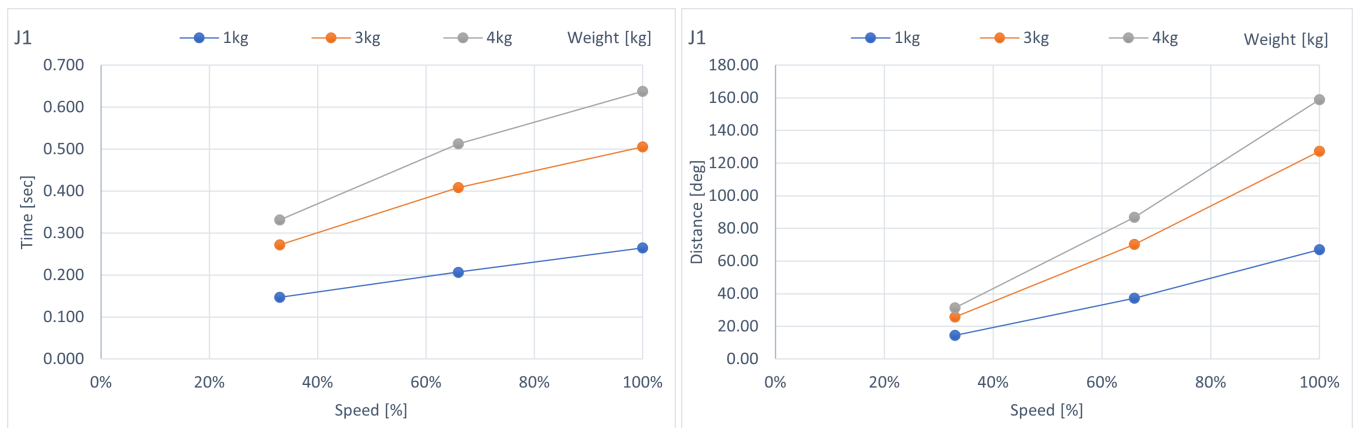

C4-B601 **: J2 (Table top mounting, Ceiling mounting)

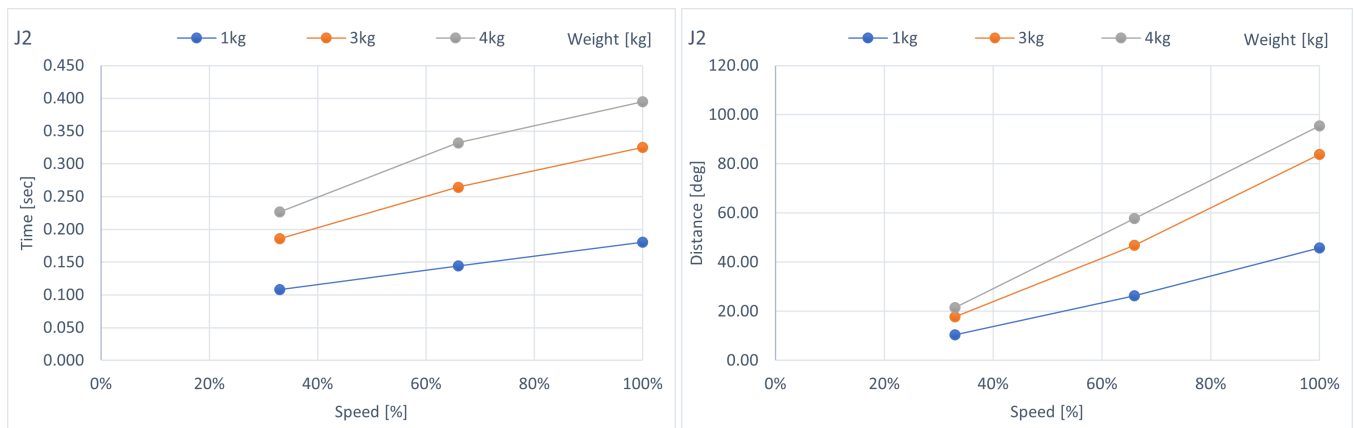

C4-B601 **: J3 (Table top mounting, Ceiling mounting)

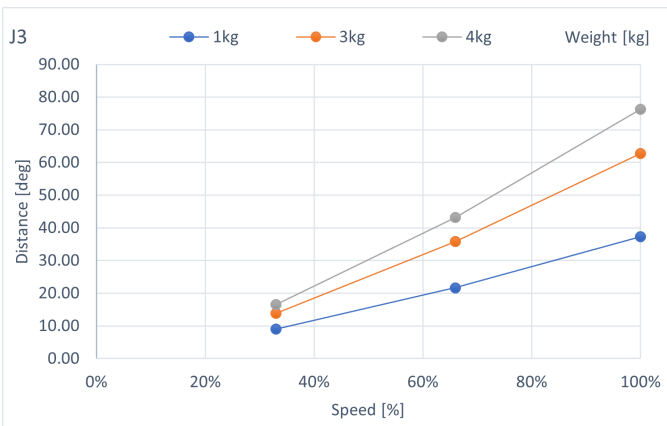
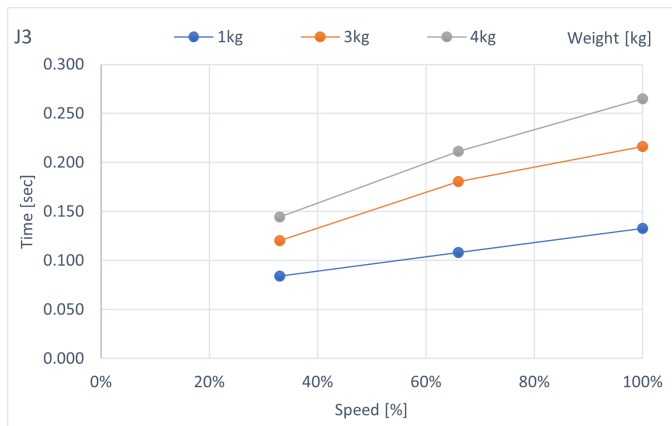

C4-B601 **: J4 (Table top mounting, Ceiling mounting)

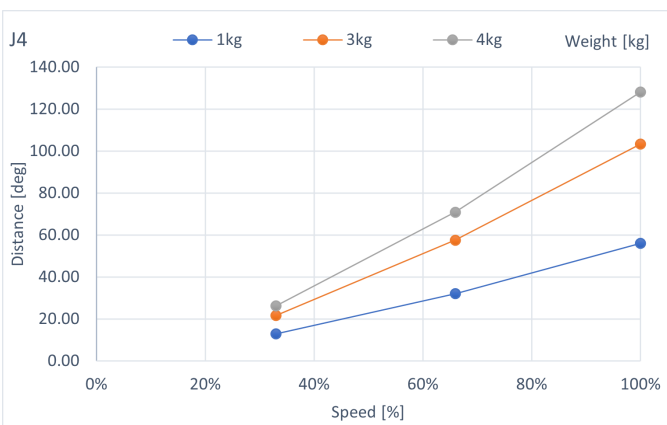
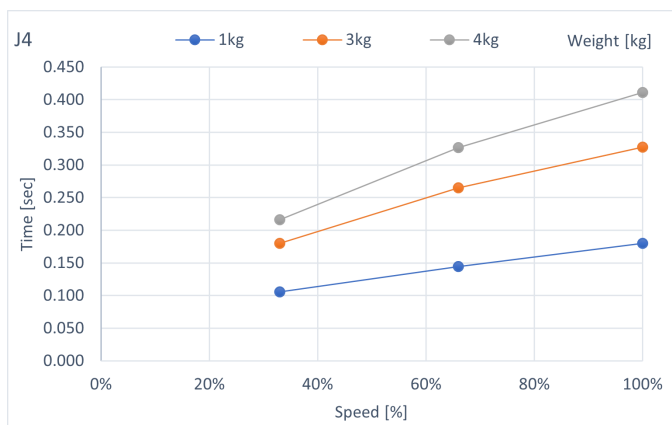

C4-B601 **: J5 (Table top mounting, Ceiling mounting)

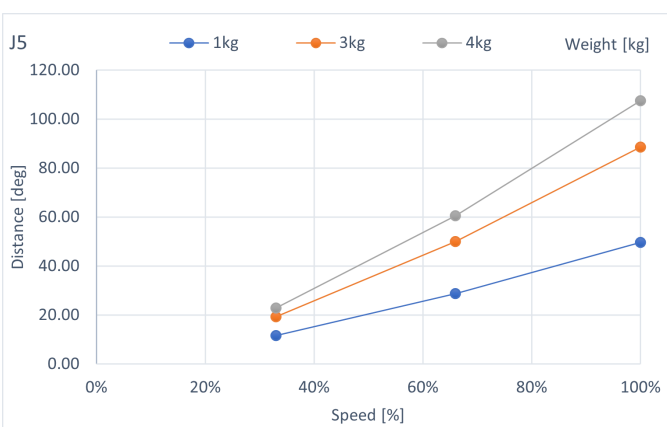
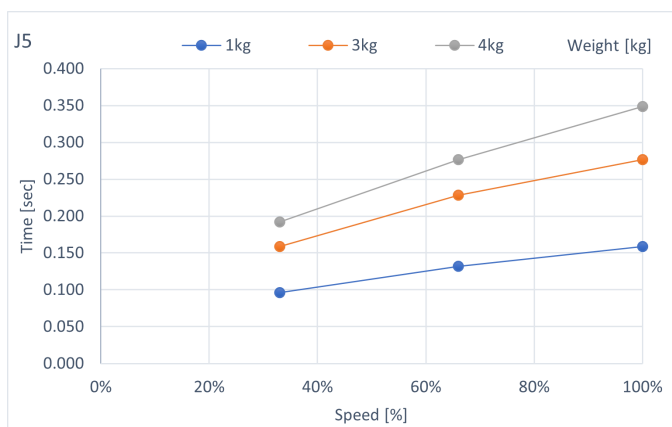

C4-B601 **: J6 (Table top mounting, Ceiling mounting)

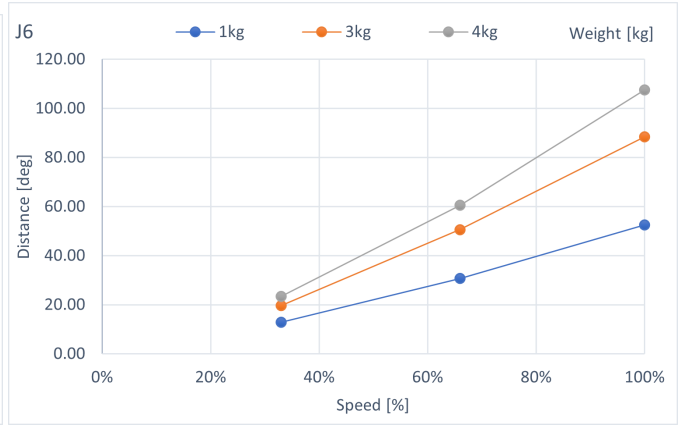
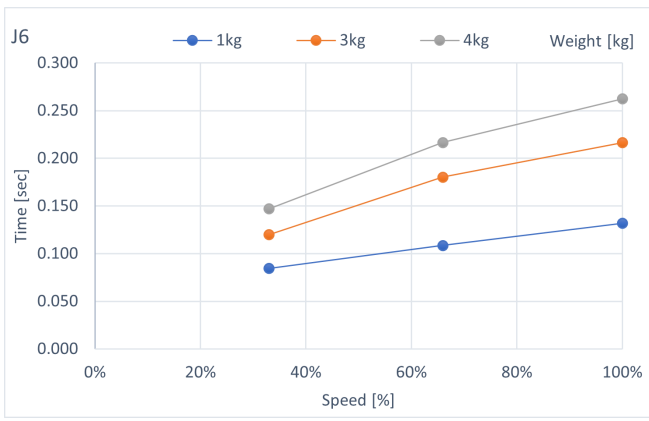

C4-B901**: J1 (Table top mounting, Ceiling mounting)

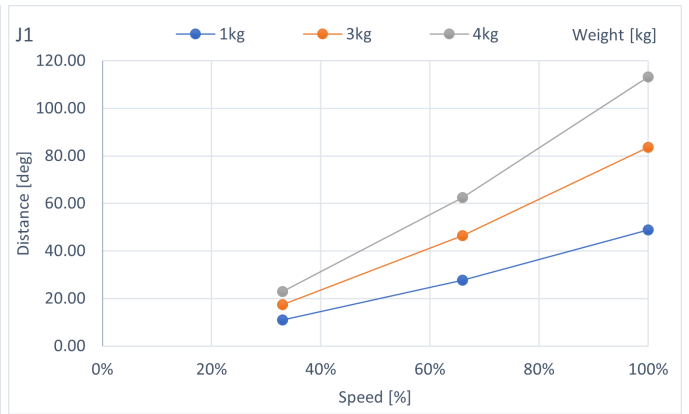
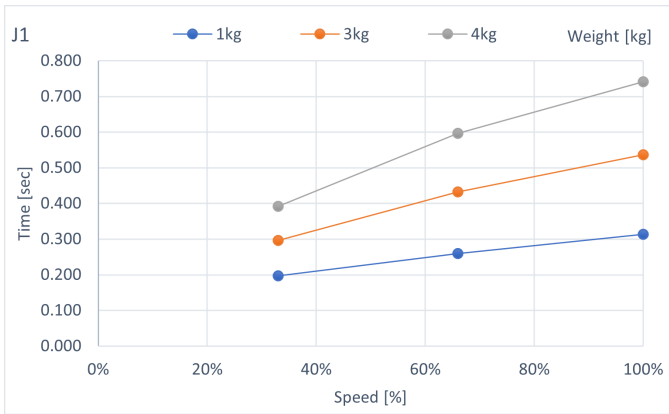

C4-B901**: J2 (Table top mounting, Ceiling mounting)

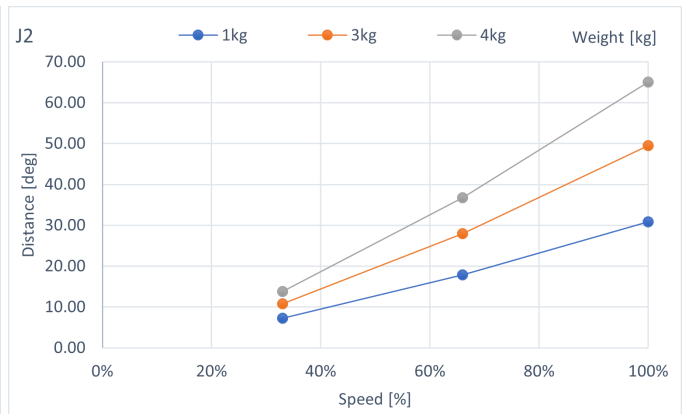
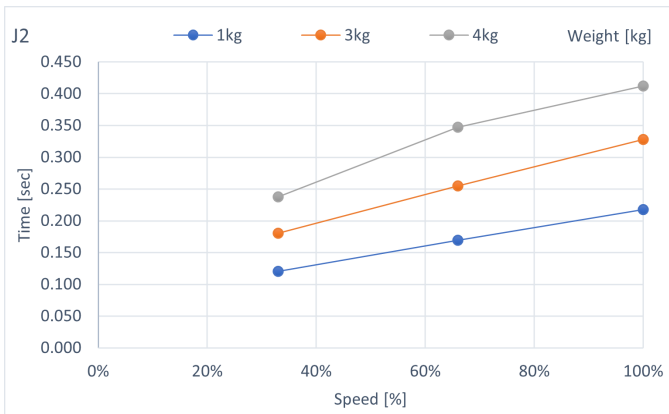

C4-B901**: J3 (Table top mounting, Ceiling mounting)

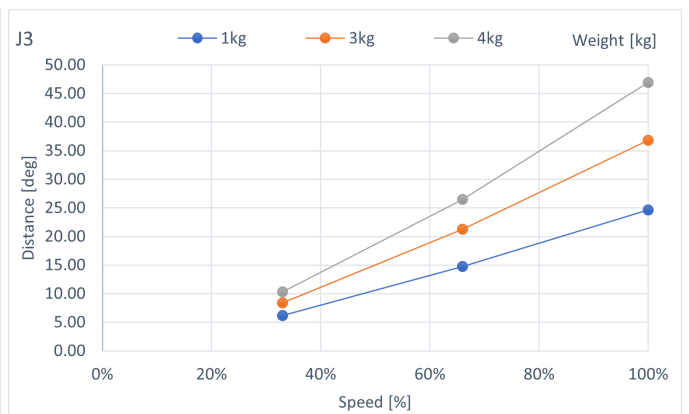
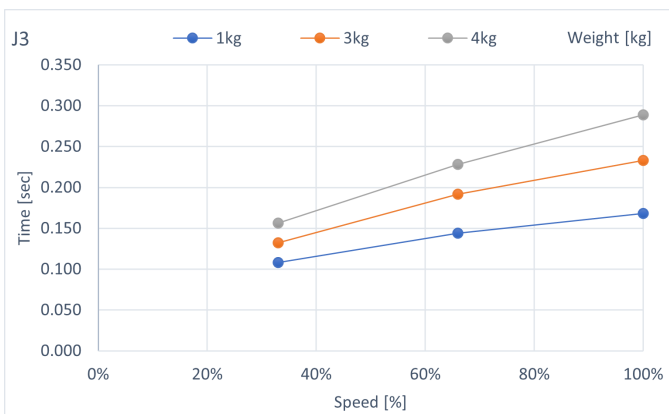

C4-B901 **: J4 (Table top mounting, Ceiling mounting)

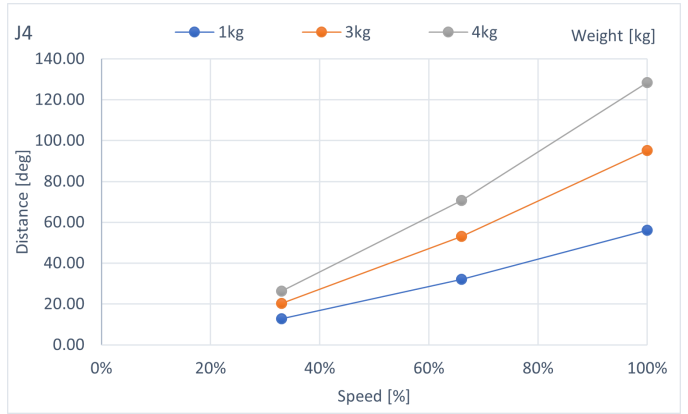
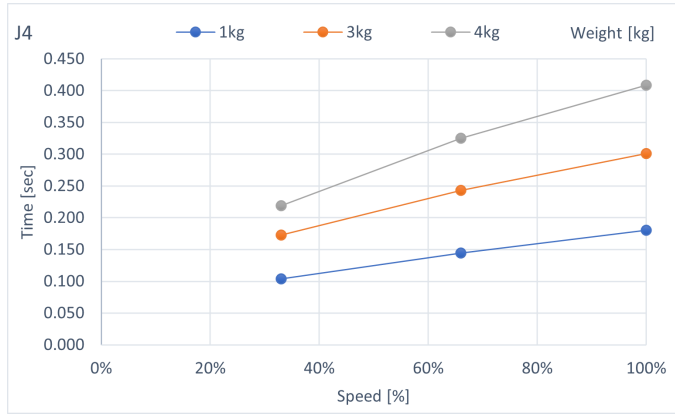

C4-B901 **: J5 (Table top mounting, Ceiling mounting)

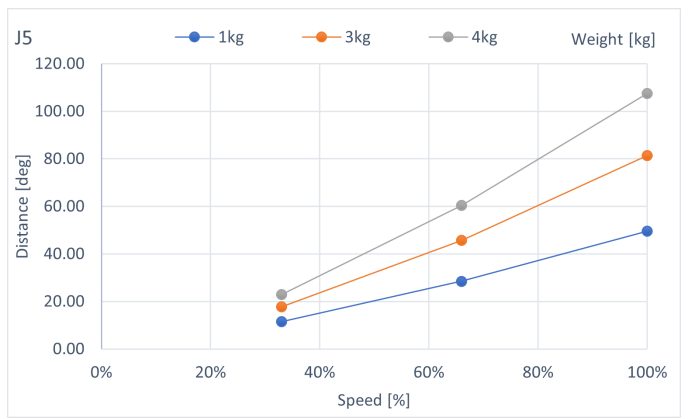
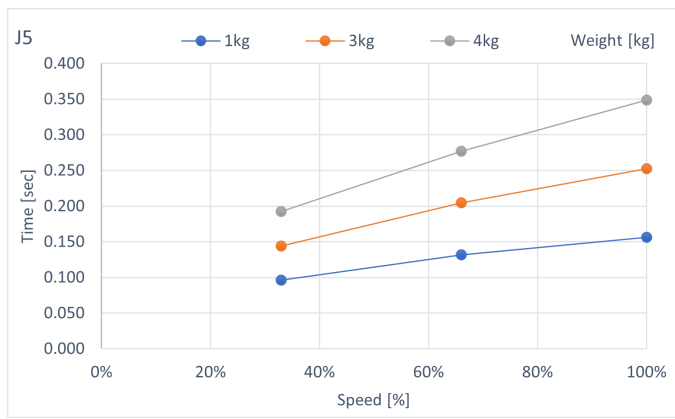

C4-B901 **: J6 (Table top mounting, Ceiling mounting)

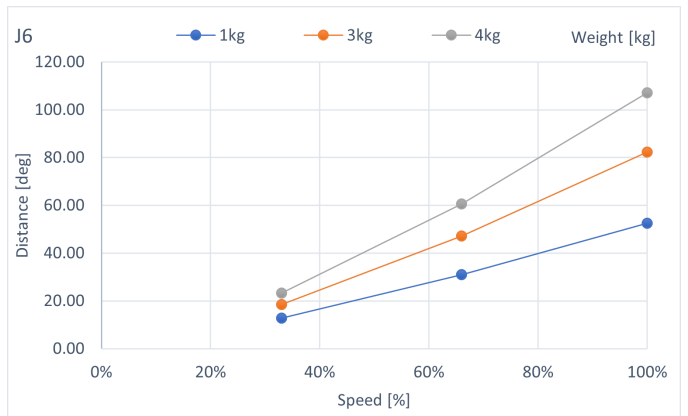
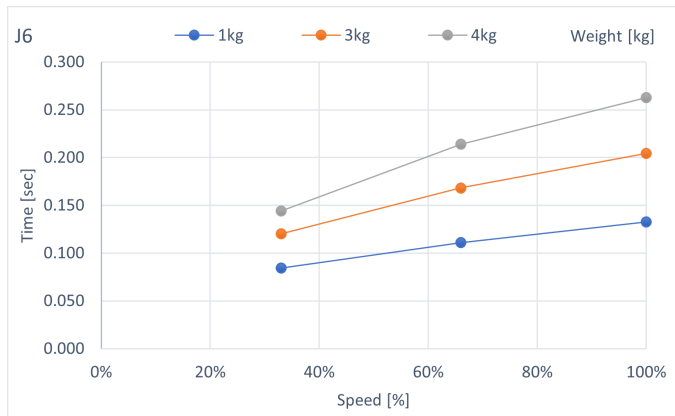

6.2.2 C8-B Stopping Time and Stopping Distance at Emergency Stop

C8-B901 ***: J1 (Table top mounting, Ceiling mounting)

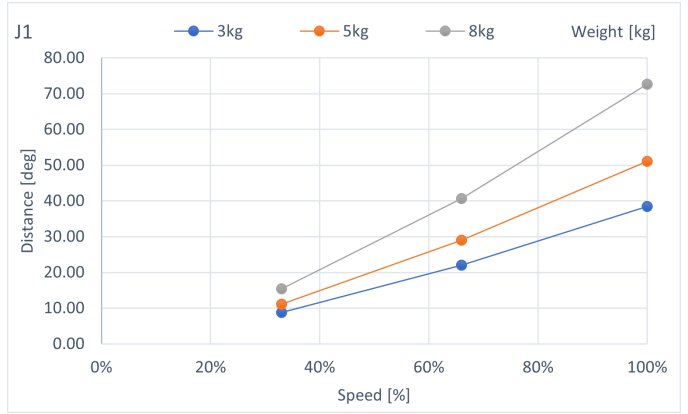
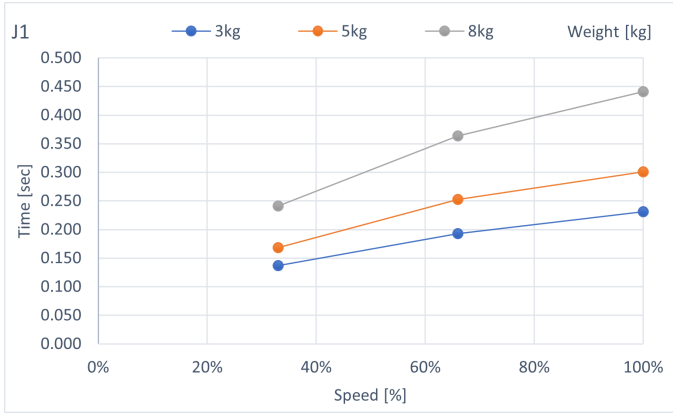

C8-B901***: J2 (Table top mounting, Ceiling mounting)

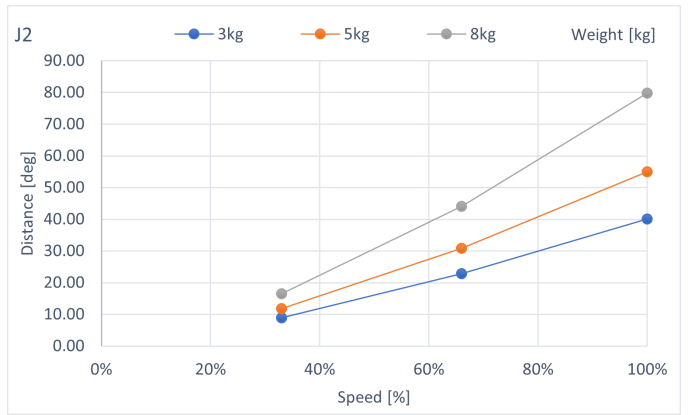
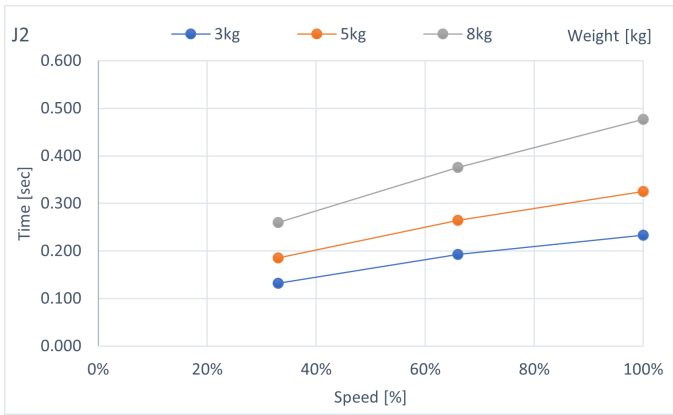

C8-B901***: J3 (Table top mounting, Ceiling mounting)

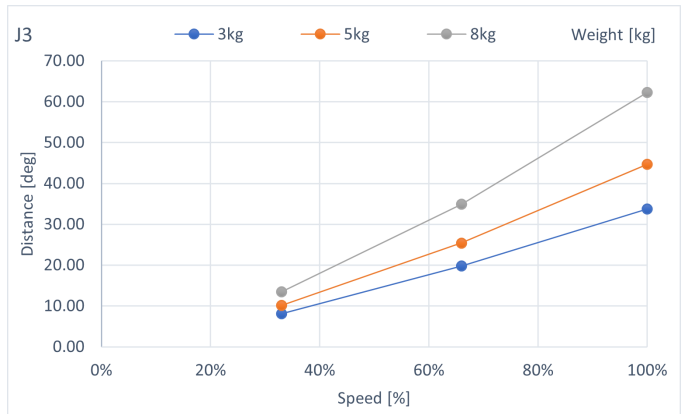
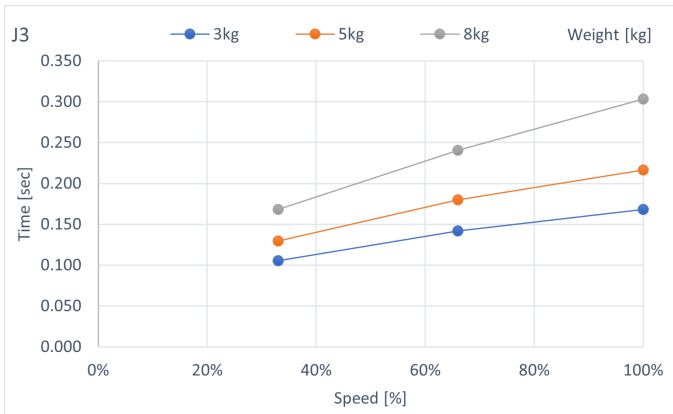

C8-B901***: J4 (Table top mounting, Ceiling mounting)

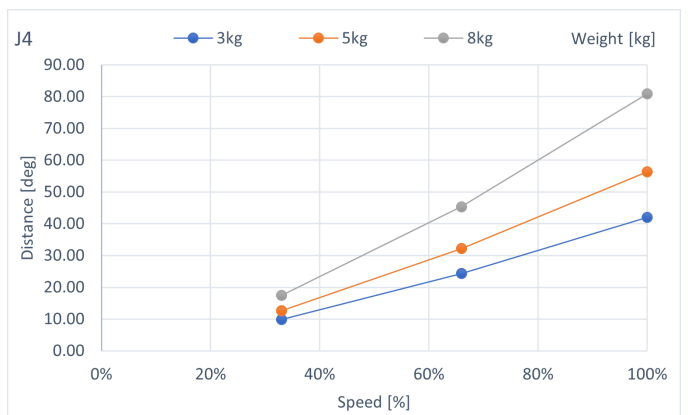
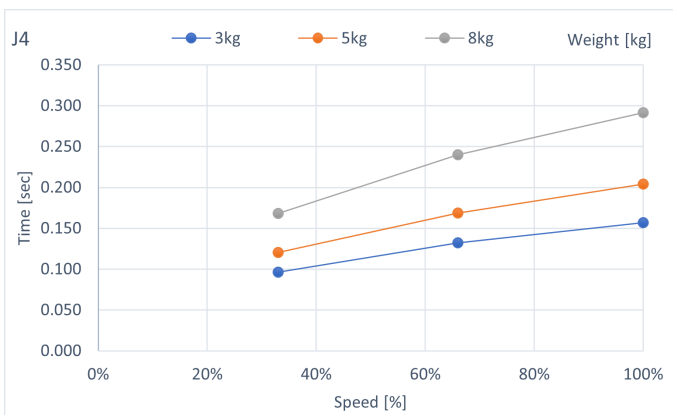

C8-B901***: J5 (Table top mounting, Ceiling mounting)

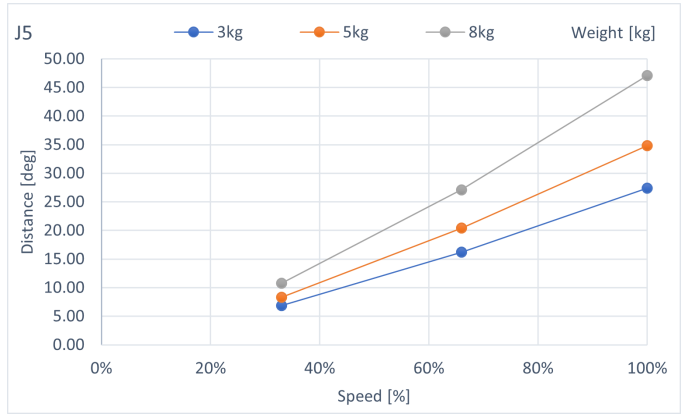
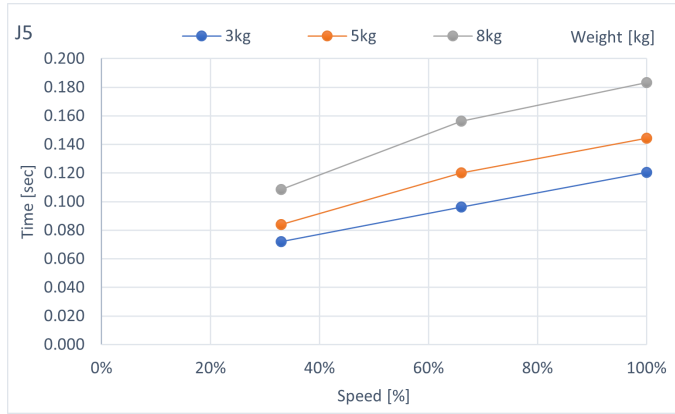

C8-B901***: J6 (Table top mounting, Ceiling mounting)

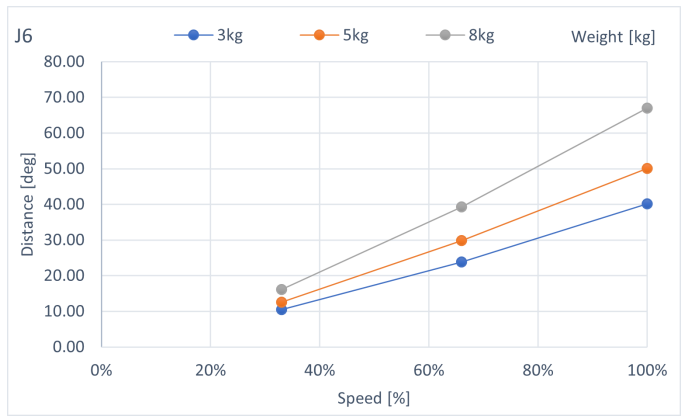
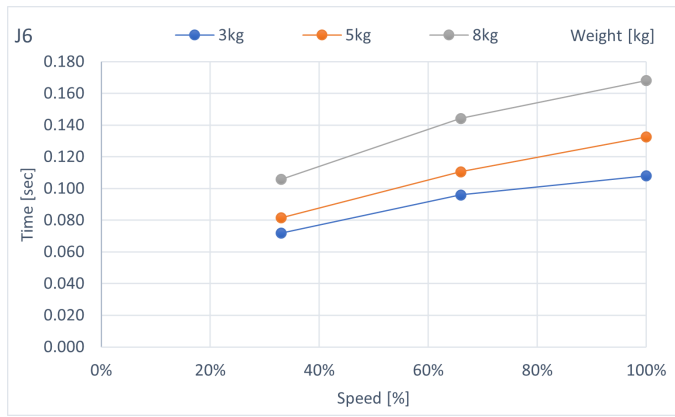

C8-B901***: J1 (Wall mounting)

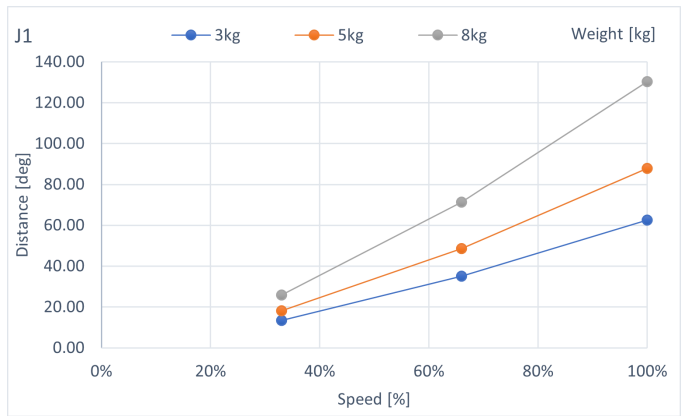
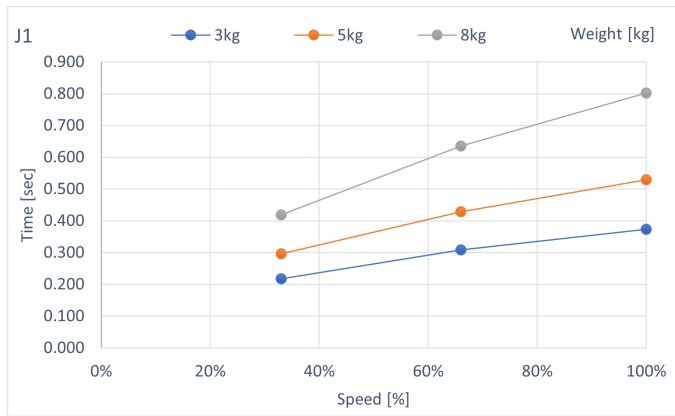

C8-B901***: J2 (Wall mounting)

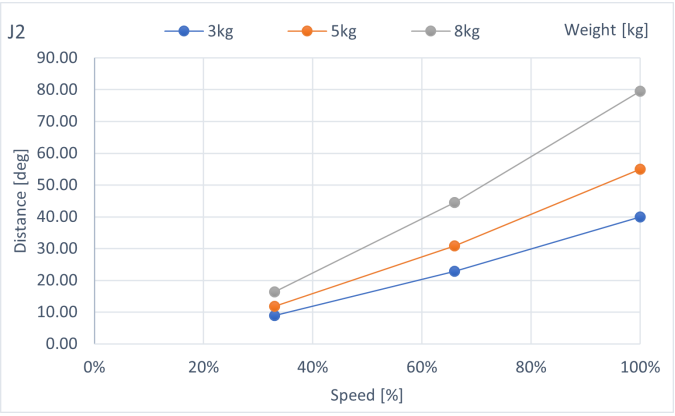
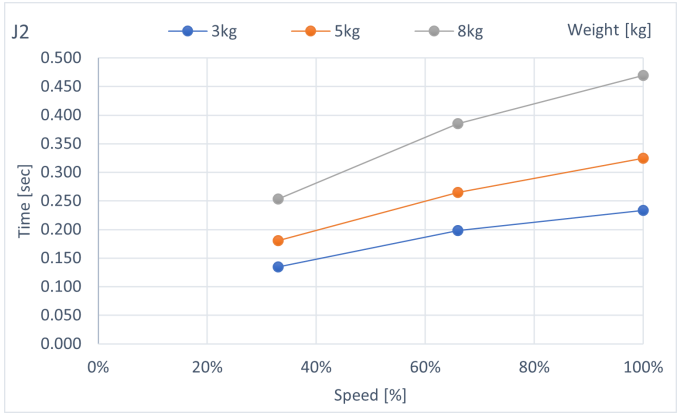

C8-B901***: J3 (Wall mounting)

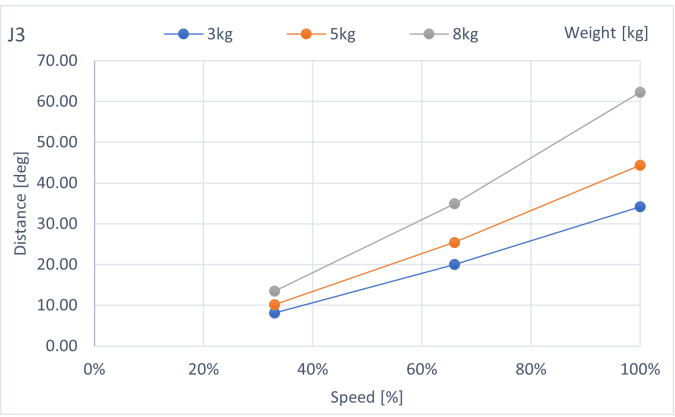
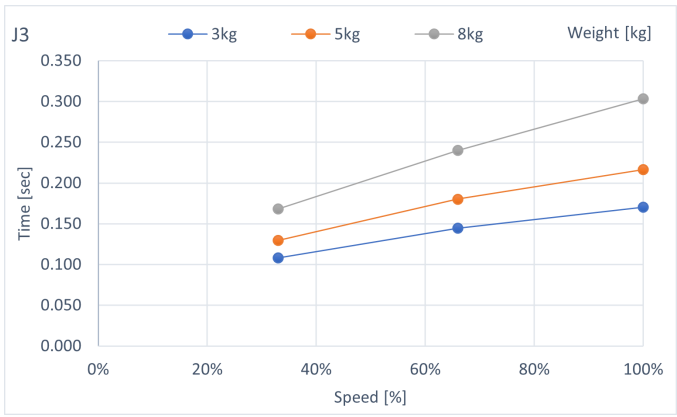

C8-B901***: J4 (Wall mounting)

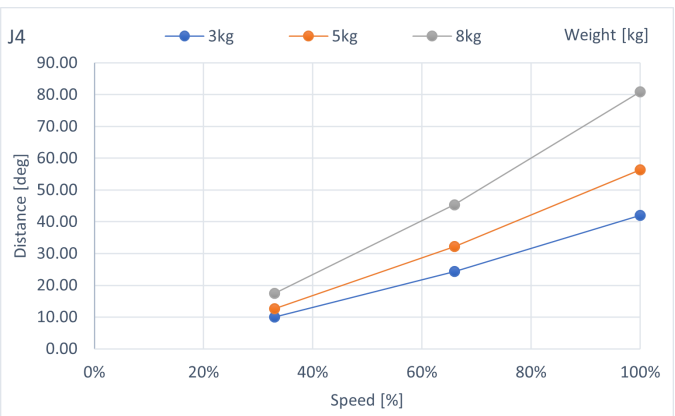
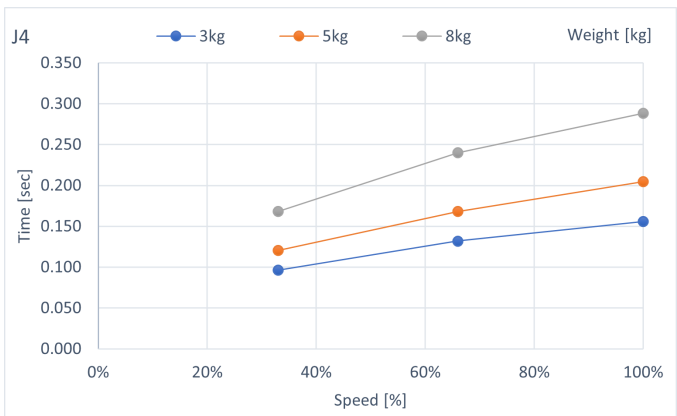

C8-B901***: J5 (Wall mounting)

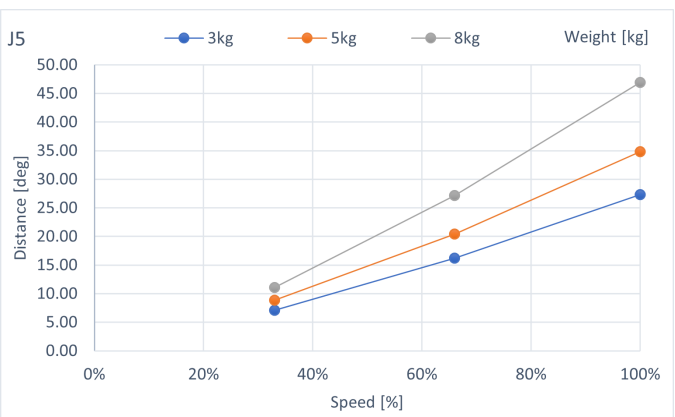
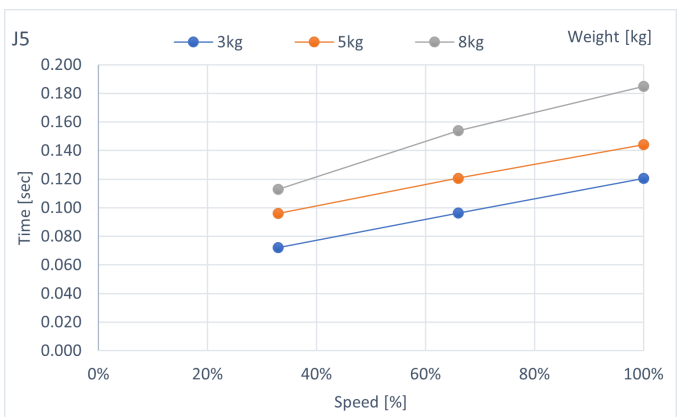

C8-B901***: J6 (Wall mounting)

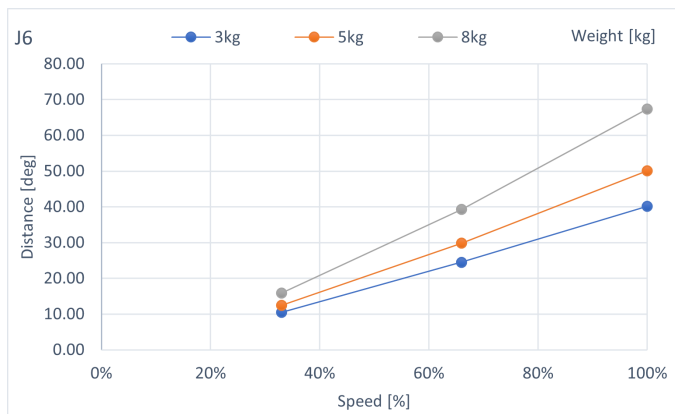
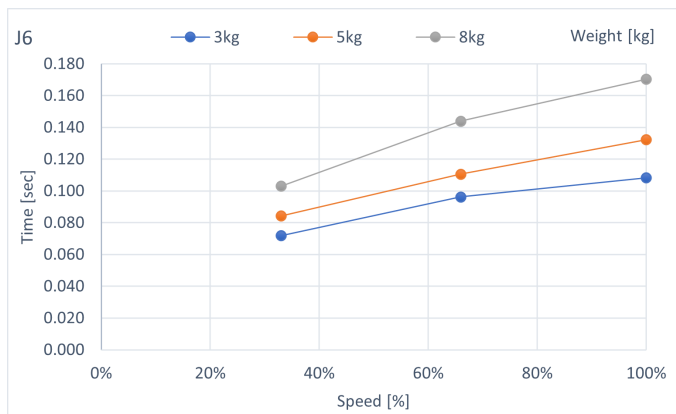

C8-B1401***: J1 (Table top mounting, Ceiling mounting)

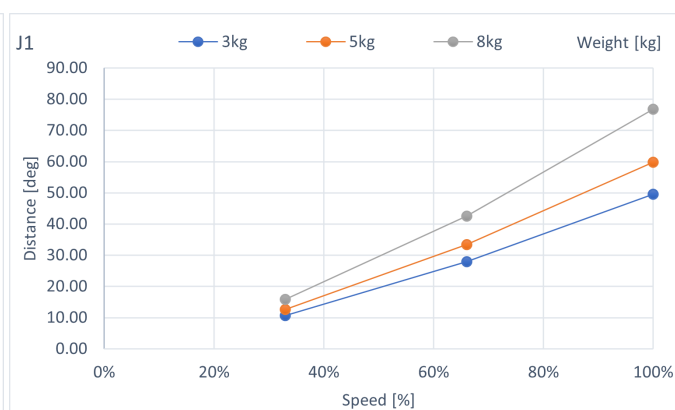
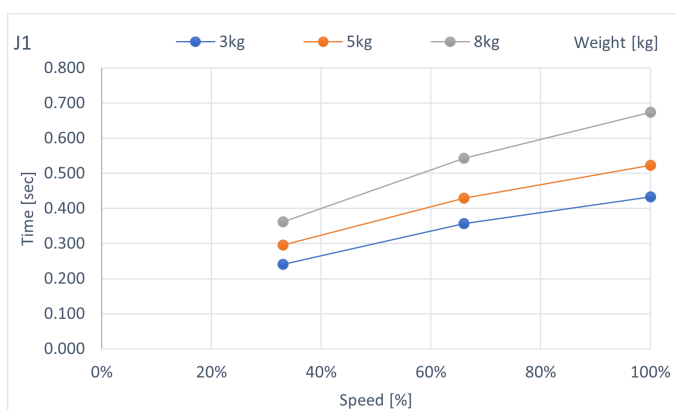

C8-B1401***: J2 (Table top mounting, Ceiling mounting)

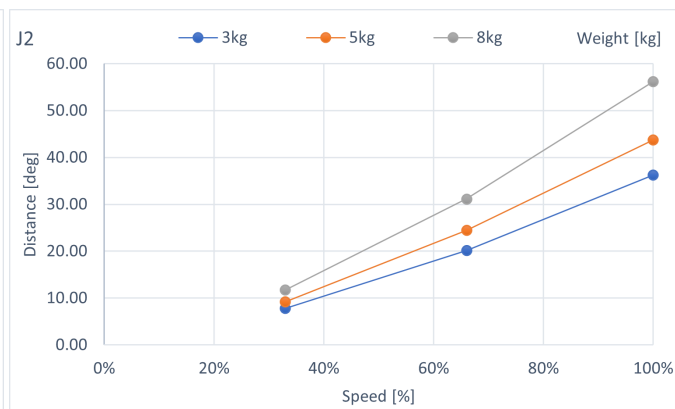
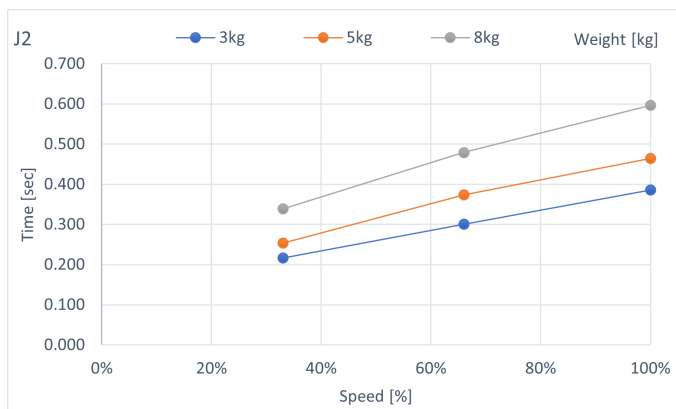

C8-B1401***: J3 (Table top mounting, Ceiling mounting)

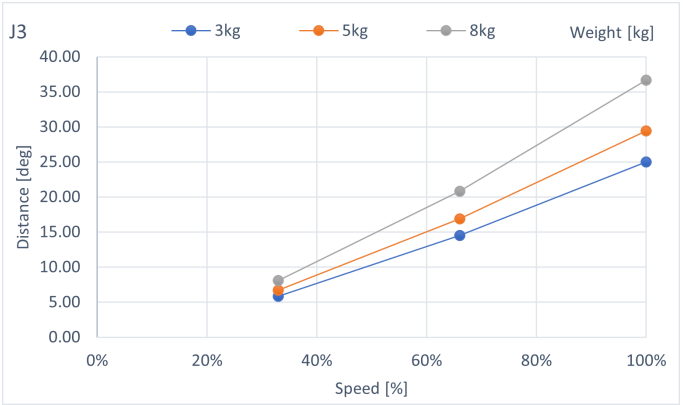
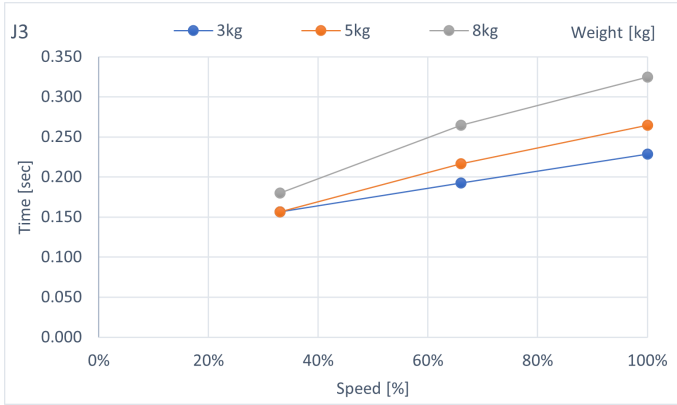

C8-B1401***: J4 (Table top mounting, Ceiling mounting)

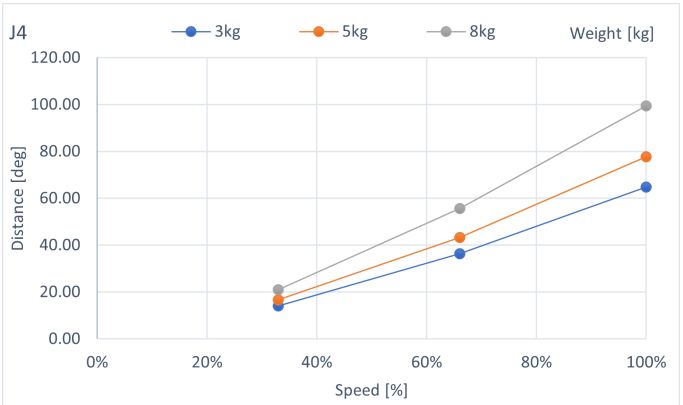
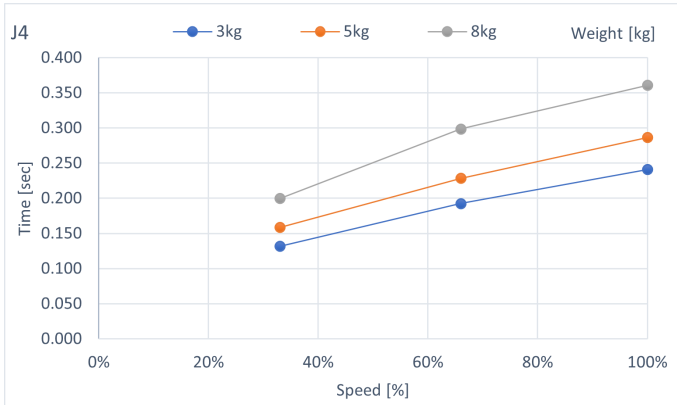

C8-B1401***: J5 (Table top mounting, Ceiling mounting)

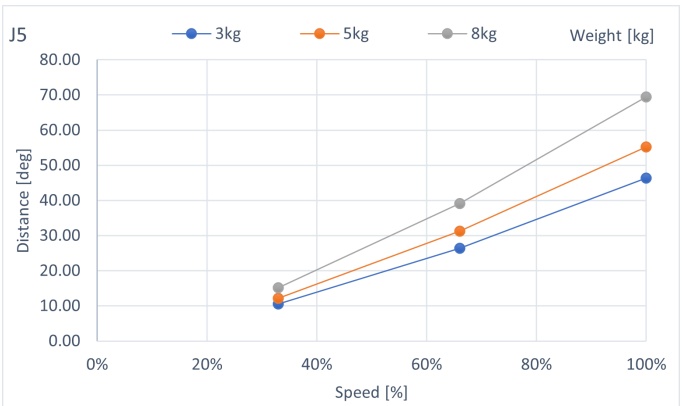
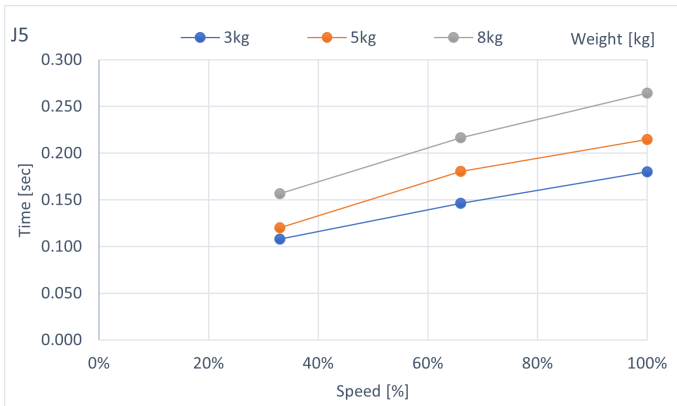

C8-B1401***: J6 (Table top mounting, Ceiling mounting)

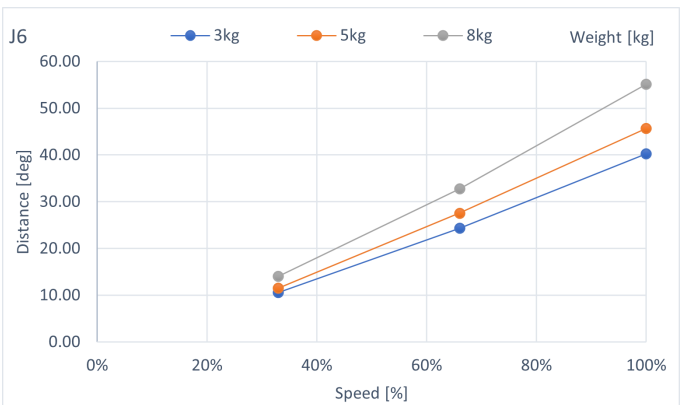
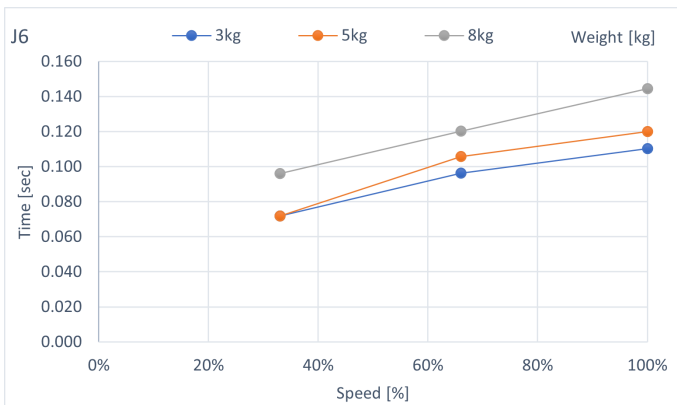

C8-B1401***: J1 (Wall mounting)

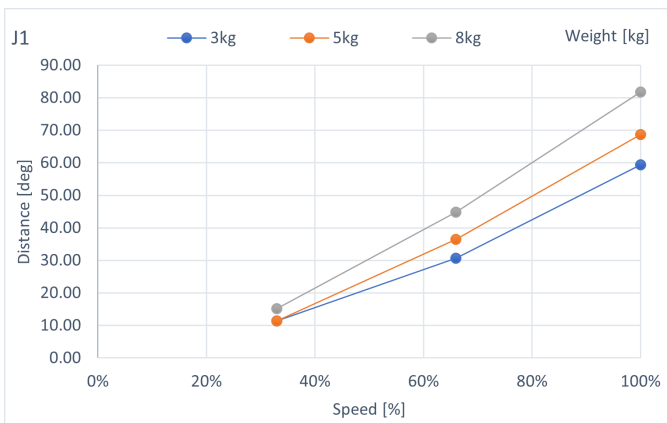
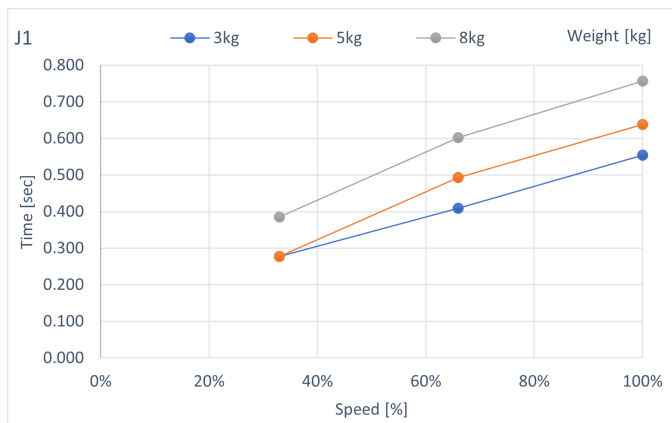

C8-B1401***: J2 (Wall mounting)

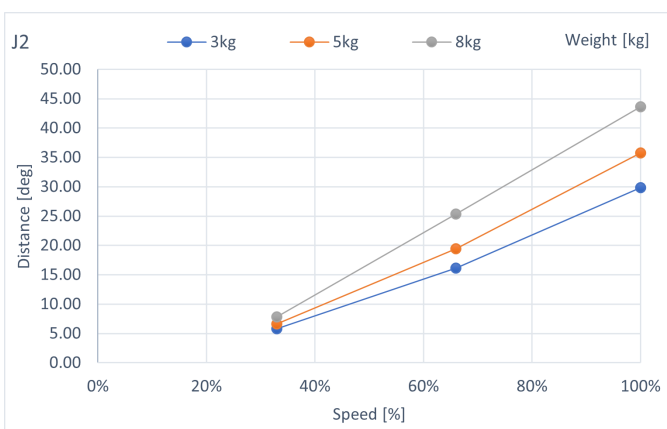
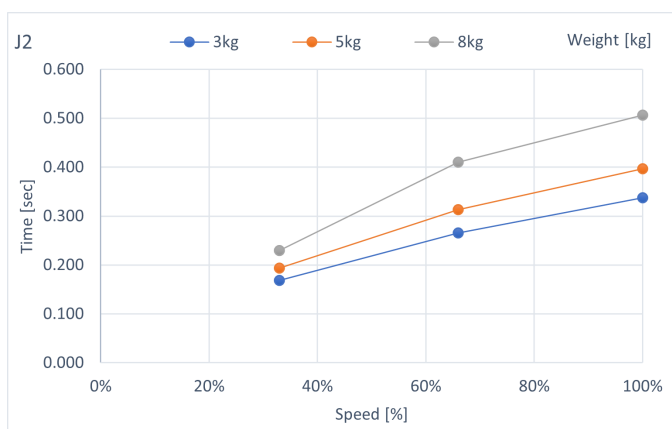

C8-B1401***: J3 (Wall mounting)

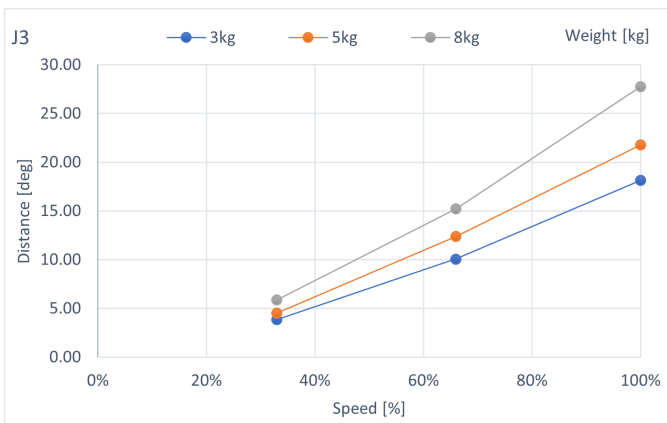
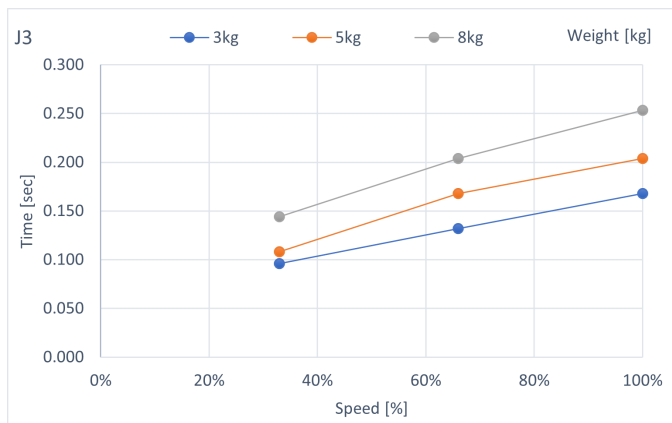

C8-B1401***: J4 (Wall mounting)

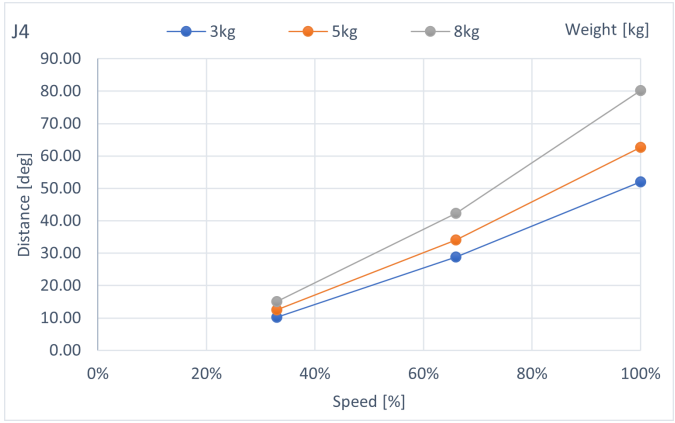
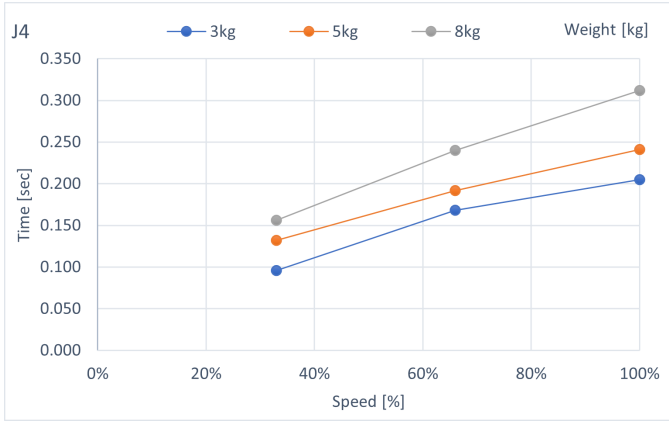

C8-B1401***: J5 (Wall mounting)

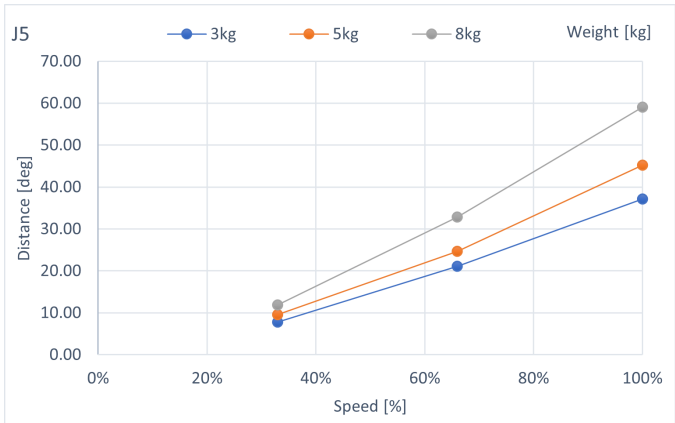
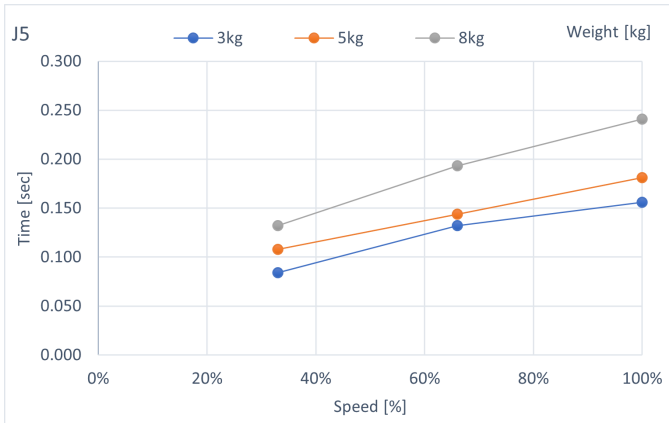

C8-B1401***: J6 (Wall mounting)

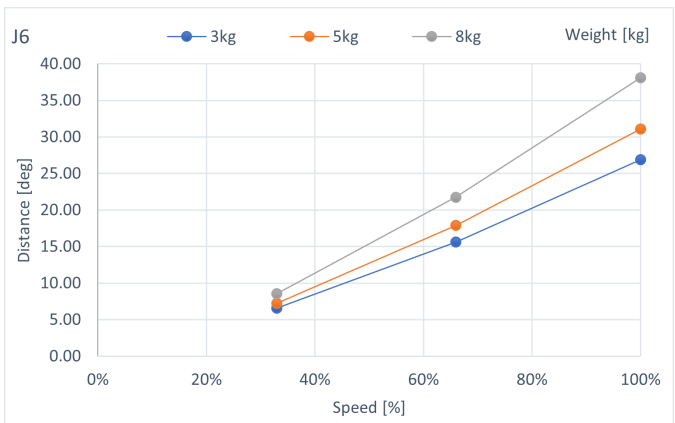
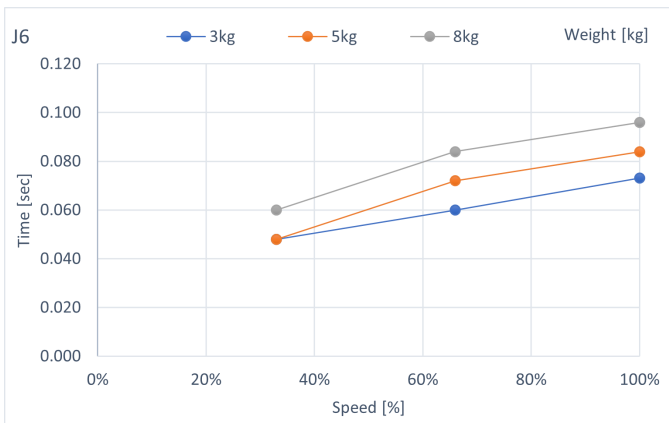

6.2.3 C12-B Stopping Time and Stopping Distance at Emergency Stop

C12-B1401**: J1 (Table top mounting)

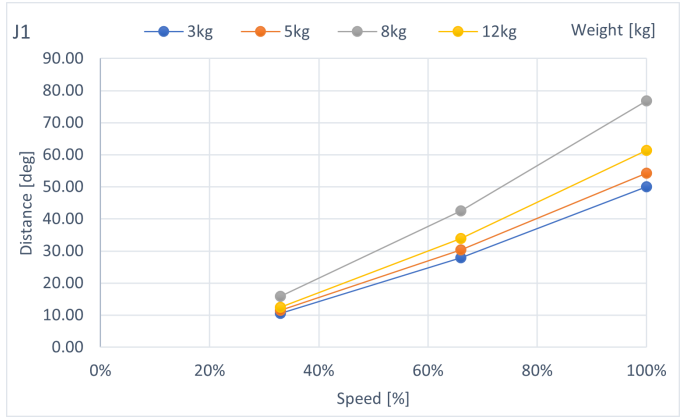
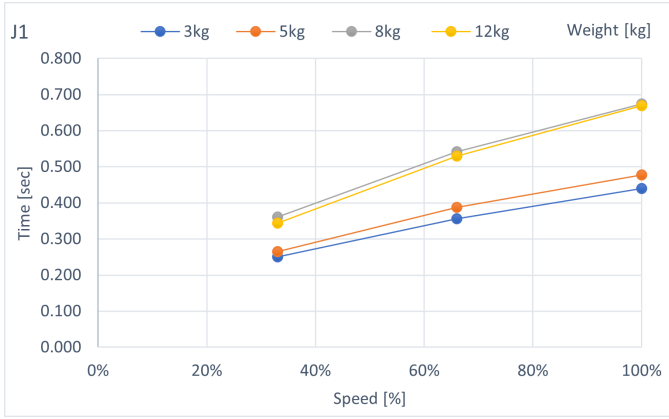

C12-B1401**: J2 (Table top mounting)

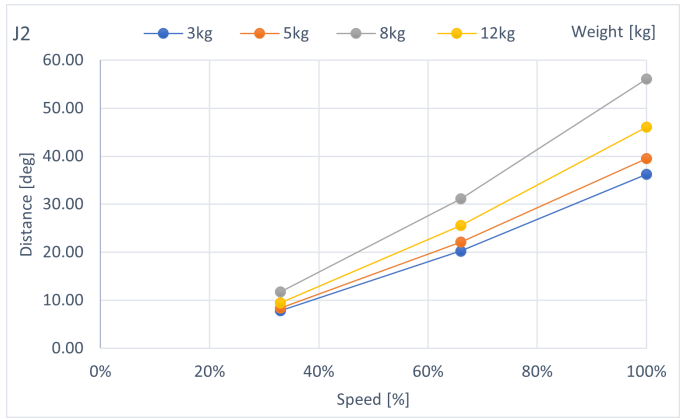
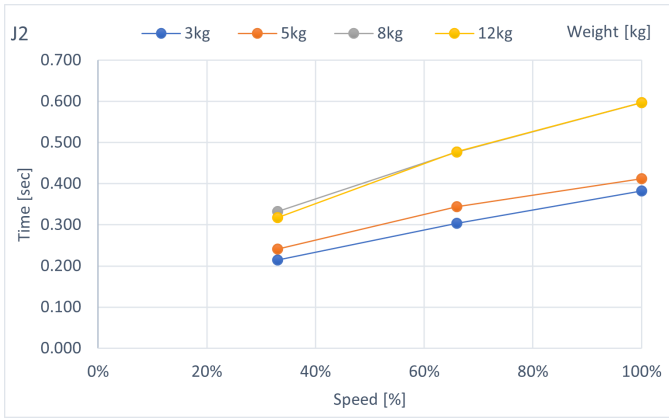

C12-B1401**: J3 (Table top mounting)

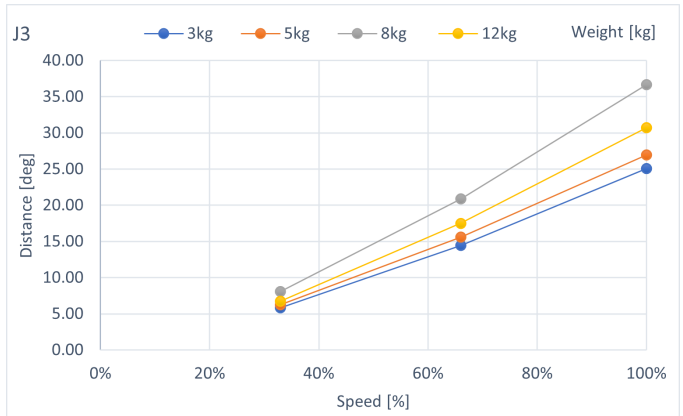
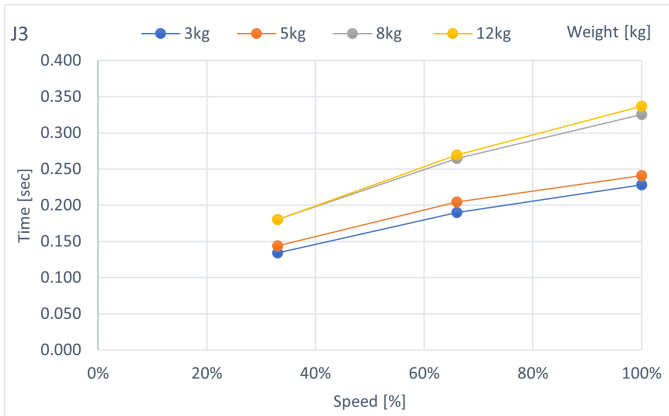

C12-B1401**: J4 (Table top mounting)

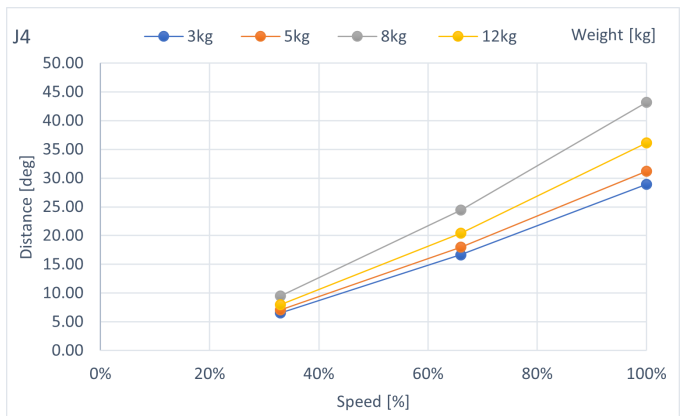
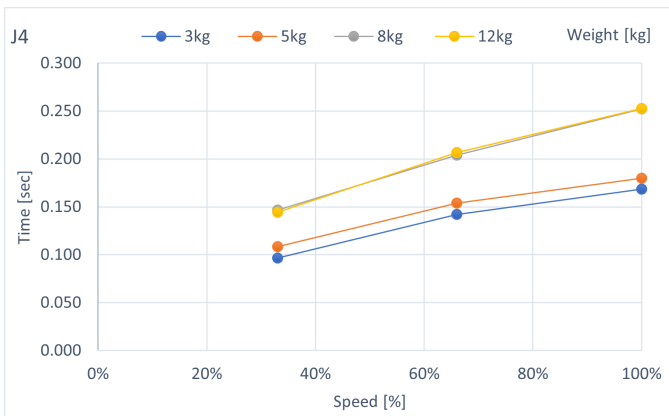

C12-B1401**: J5 (Table top mounting)

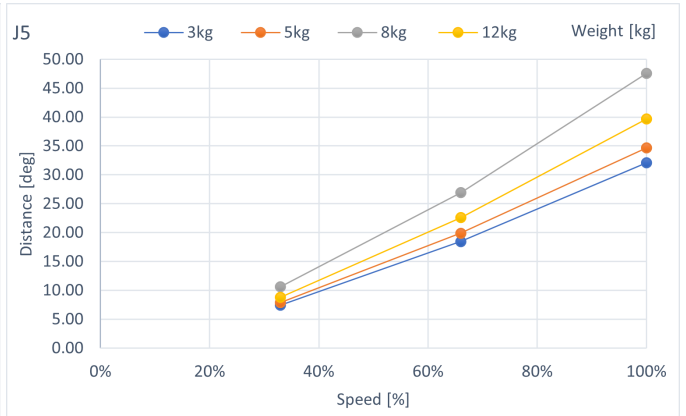
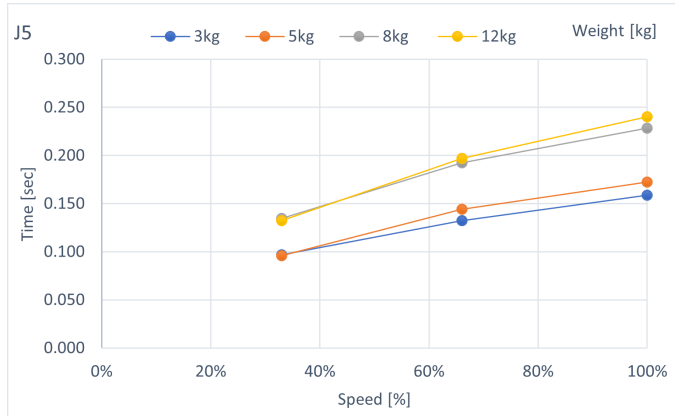

C12-B1401**: J6 (Table top mounting)

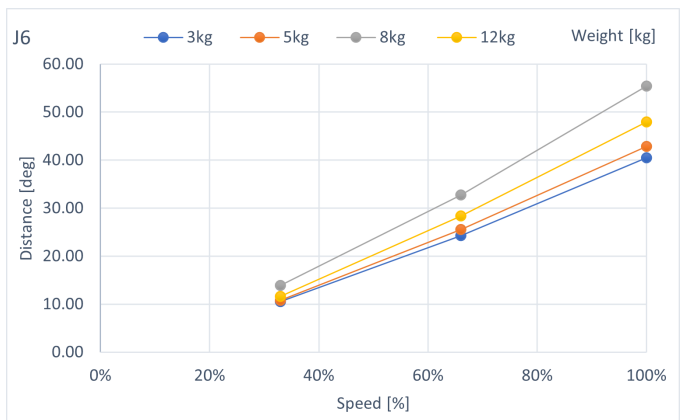
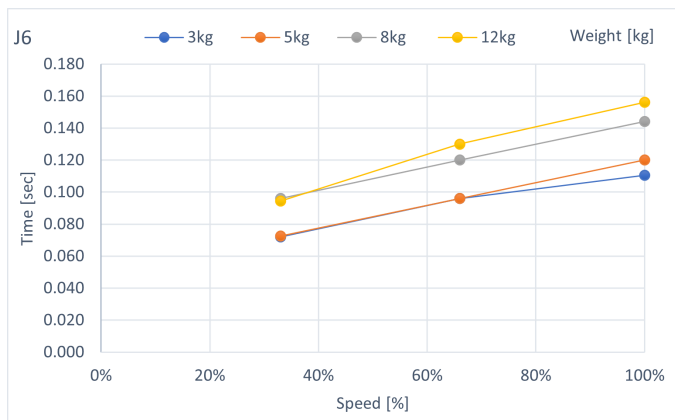

6.3 Appendix C: Stopping Time and Stopping Distance When Safeguard is Open

The stopping time and stopping distance when the safeguard is opened are shown in the graphs for each model.

The stopping time is the length of time corresponding to the "Stopping time" in the figure below. Be sure to confirm that a safe environment is provided where the robot will be installed and operated.

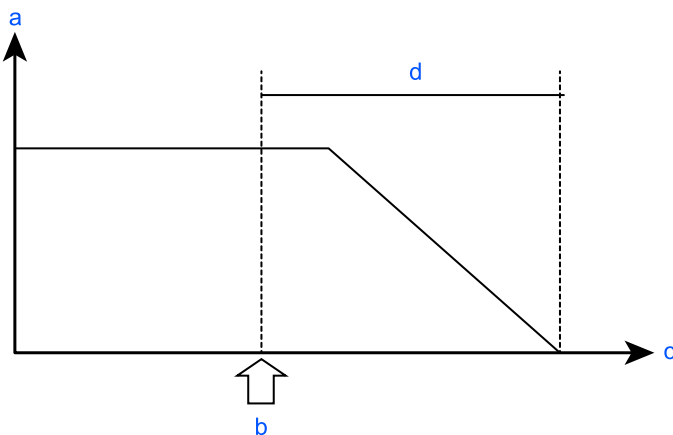

Symbol	Description
a	Motor speed

Symbol	Description
b	Safeguard open
c	Time
d	Stopping time

Conditions:

The stopping time and stopping distance depend on the parameters (setting values) that were set for the robot. These graphs show the times and distances for the following parameters.

- Accel: 100, 100
- Other settings: Default

Explanation of legend:

The graphs are displayed for each Weight setting value (at 100%, approx. 66%, and approx. 33% of the maximum payload, and at the rated payload).

- Horizontal axis: Arm speed (Speed setting)
- Vertical axis: Stopping time and stopping distance at each arm speed
- Time (sec): Stopping time (sec)
- Distance (deg): stopping distance (degree)

When single failures are taken into account, the following adjustments are used.

- Stopping distance and angle: Each axis reaches the mechanical stop
- Stopping time: Add 500 ms

6.3.1 C4-B Stopping Time and Stopping Distance When Safeguard is Open

C4-B601 **: J1 (Table top mounting, Ceiling mounting)

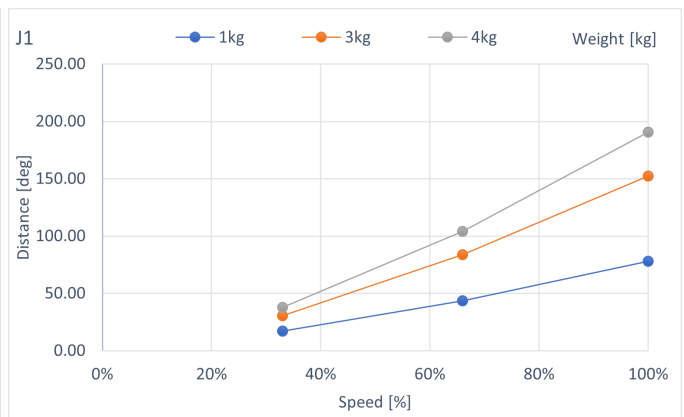
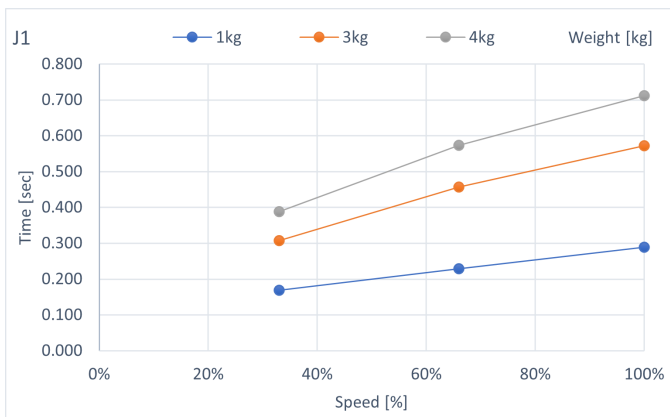

C4-B601 **: J2 (Table top mounting, Ceiling mounting)

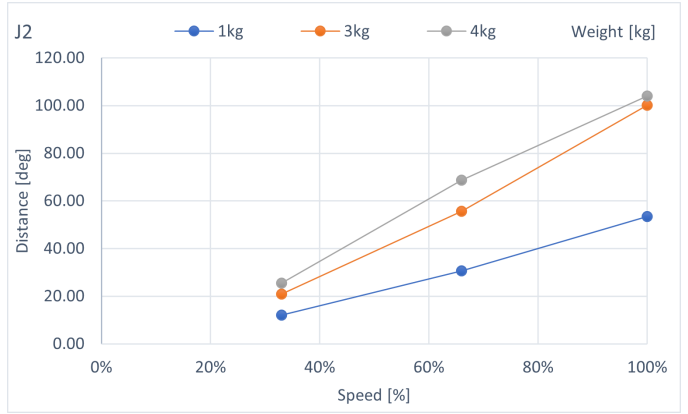
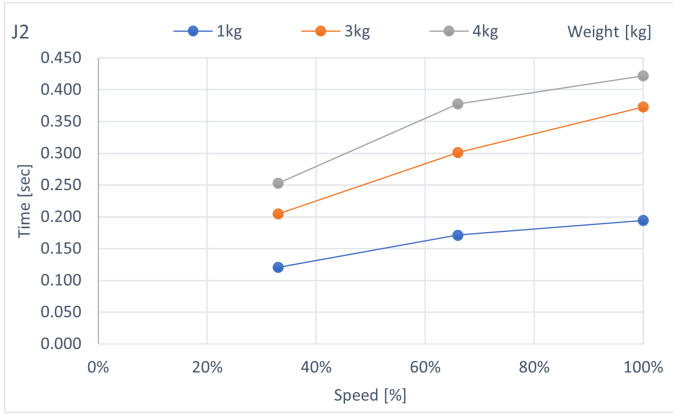

C4-B601 **: J3 (Table top mounting, Ceiling mounting)

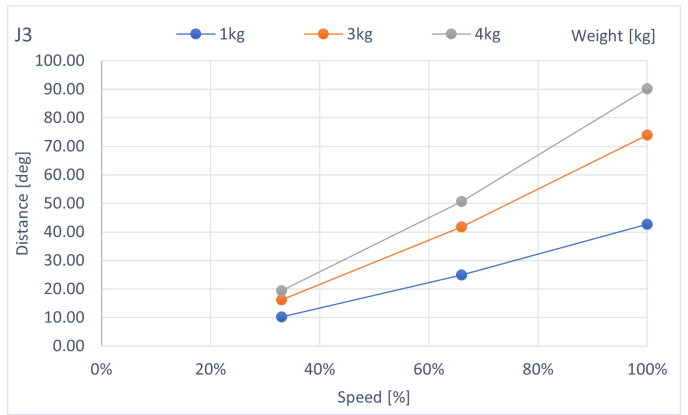
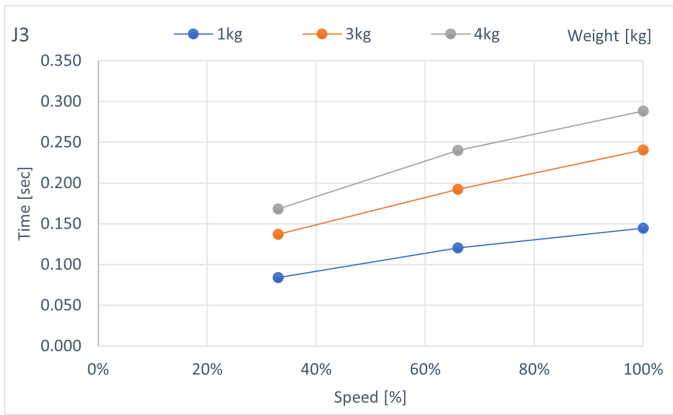

C4-B601 **: J4 (Table top mounting, Ceiling mounting)

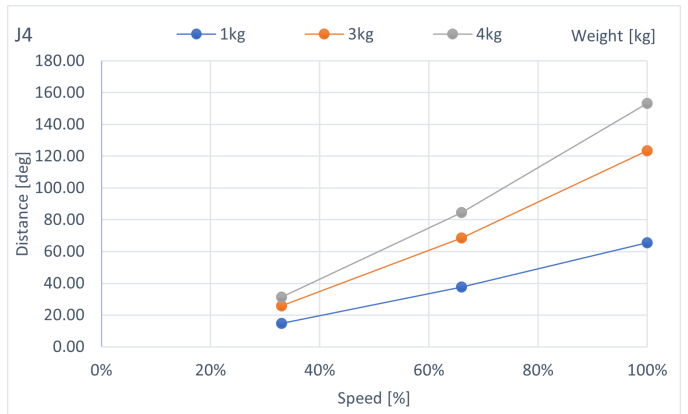
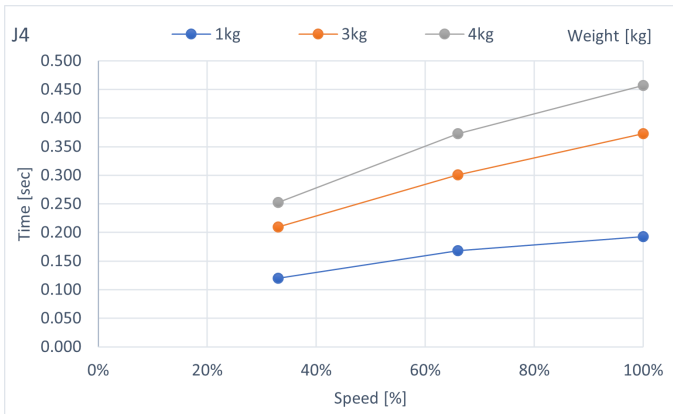

C4-B601 **: J5 (Table top mounting, Ceiling mounting)

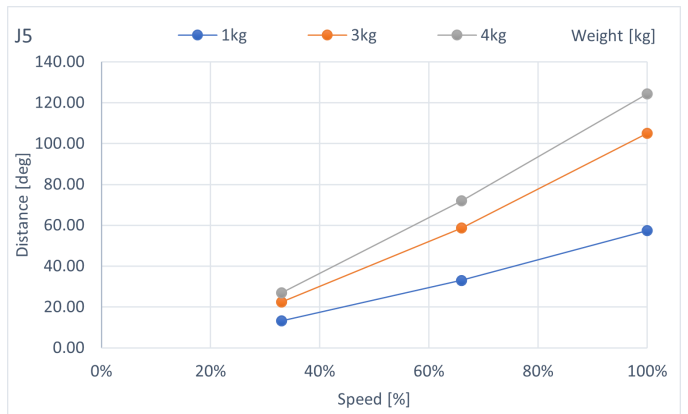
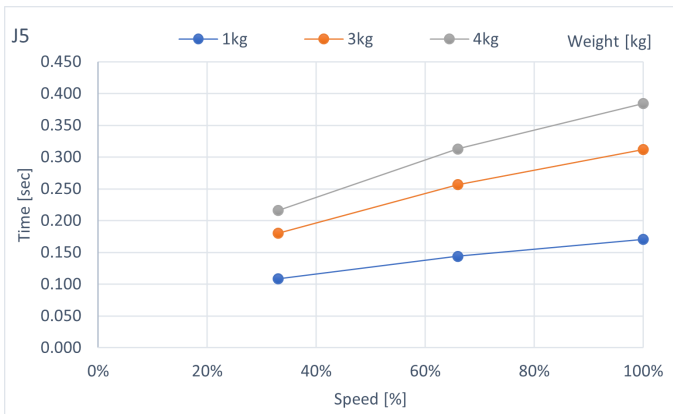

C4-B601 **: J6 (Table top mounting, Ceiling mounting)

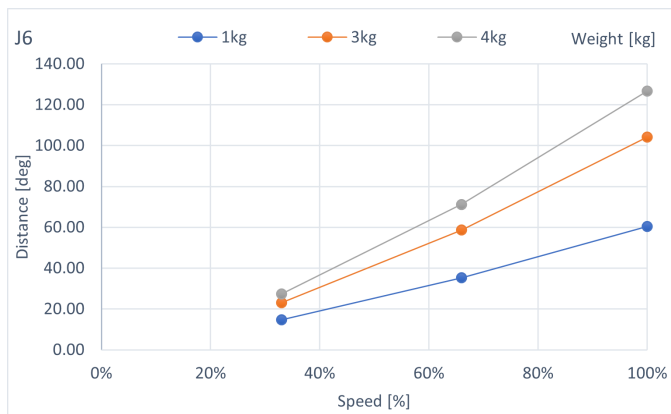
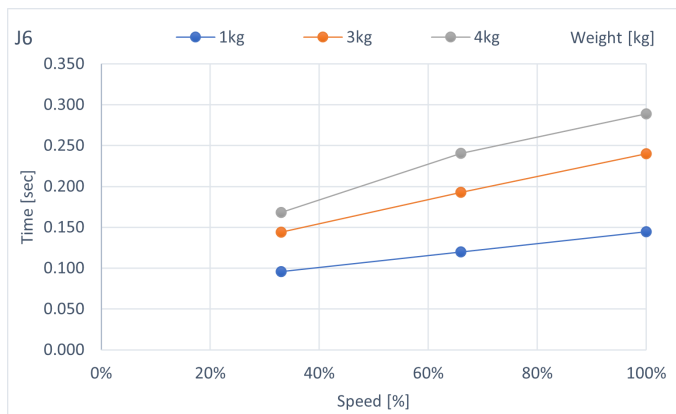

C4-B901 **: J1 (Table top mounting, Ceiling mounting)

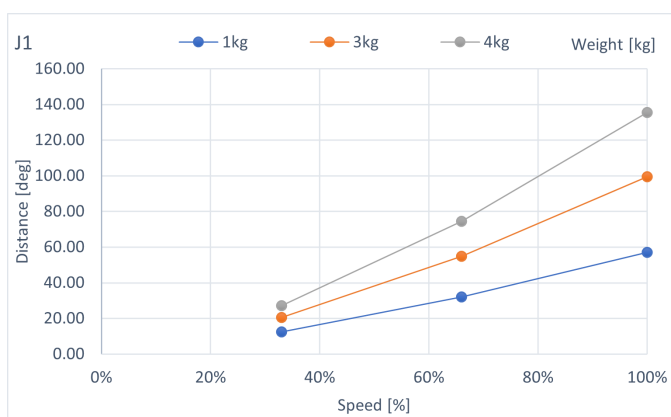
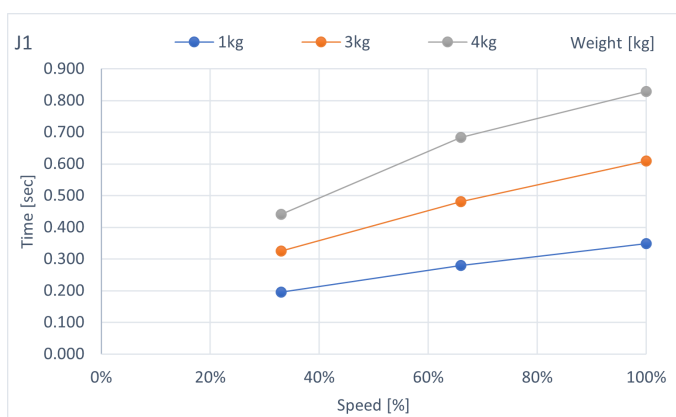

C4-B901 **: J2 (Table top mounting, Ceiling mounting)

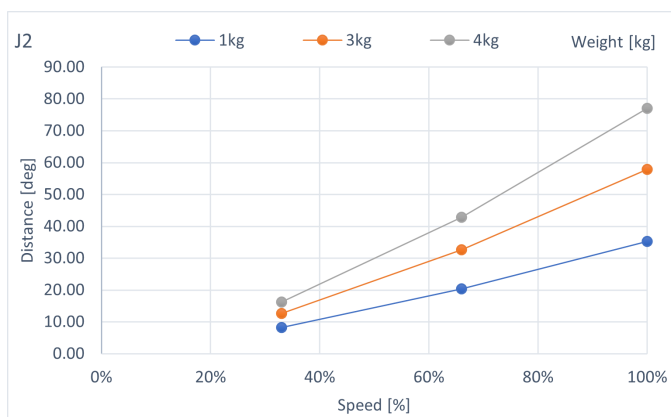
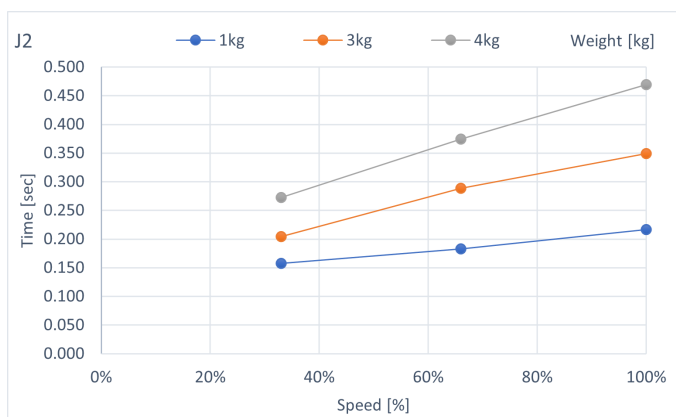

C4-B901 **: J3 (Table top mounting, Ceiling mounting)

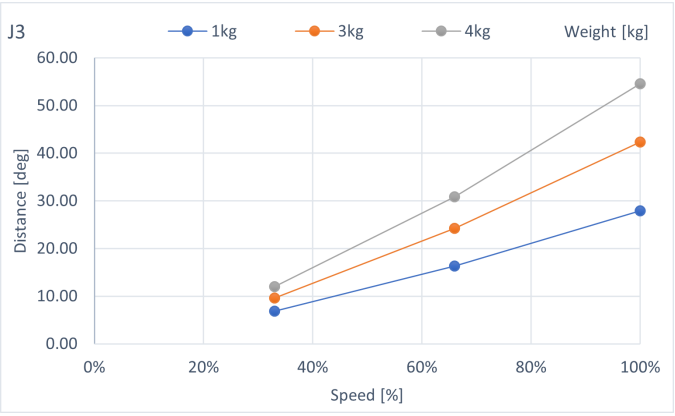
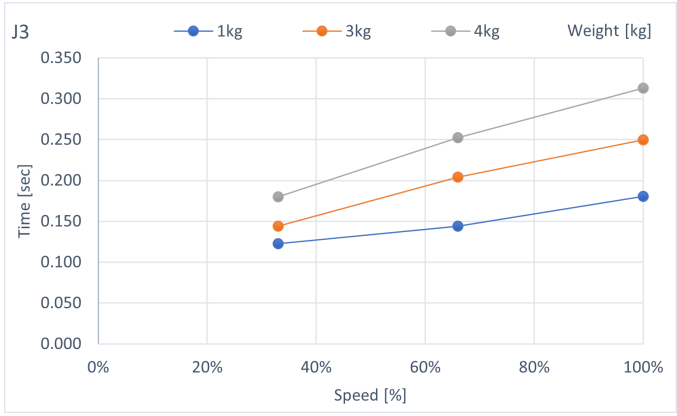

C4-B901 **: J4 (Table top mounting, Ceiling mounting)

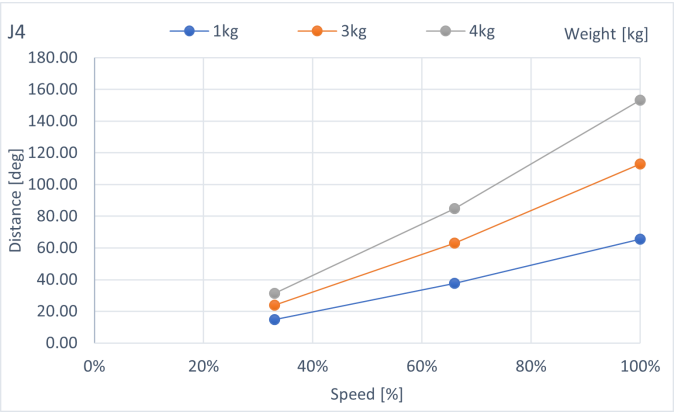
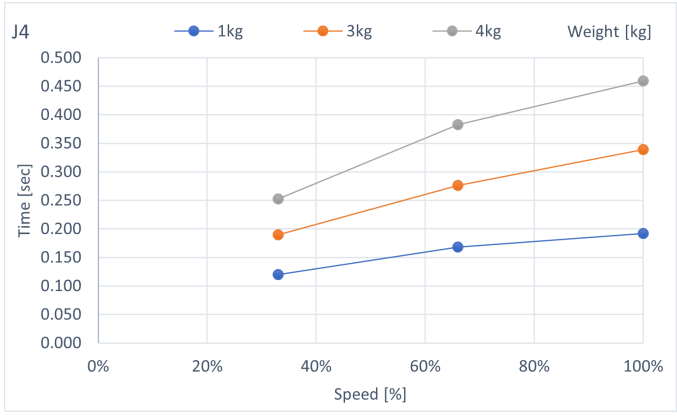

C4-B901 **: J5 (Table top mounting, Ceiling mounting)

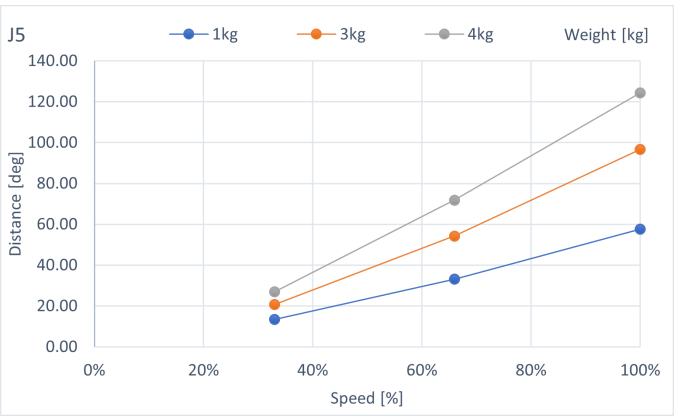
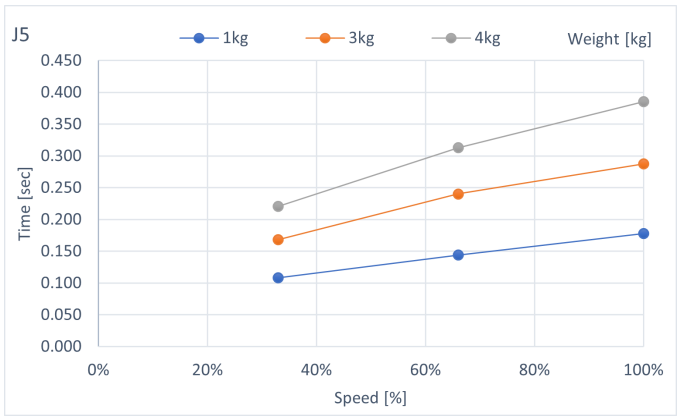

C4-B901 **: J6 (Table top mounting, Ceiling mounting)

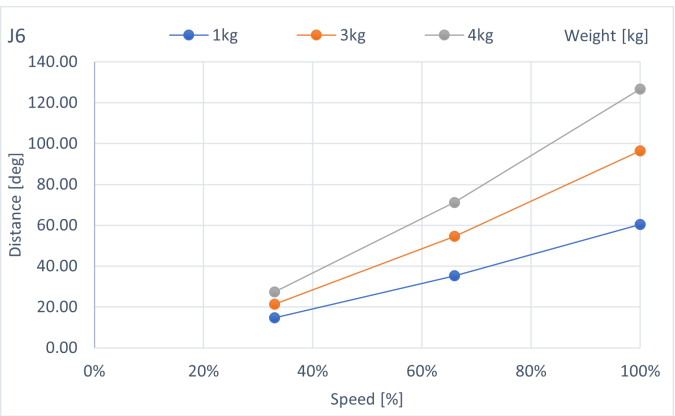
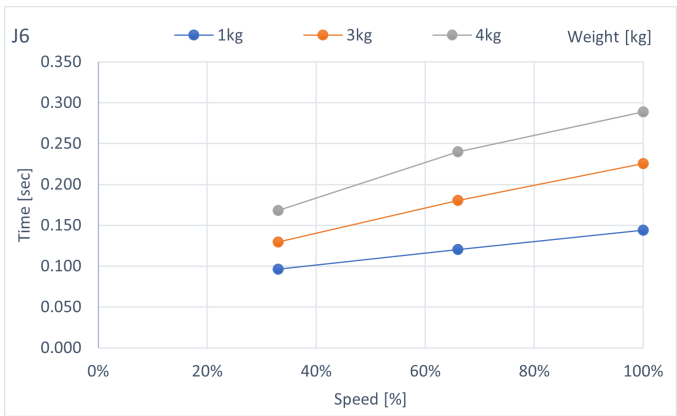

6.3.2 C8-B Stopping Time and Stopping Distance When Safeguard is Open

C8-B901***: J1 (Table top mounting, Ceiling mounting)

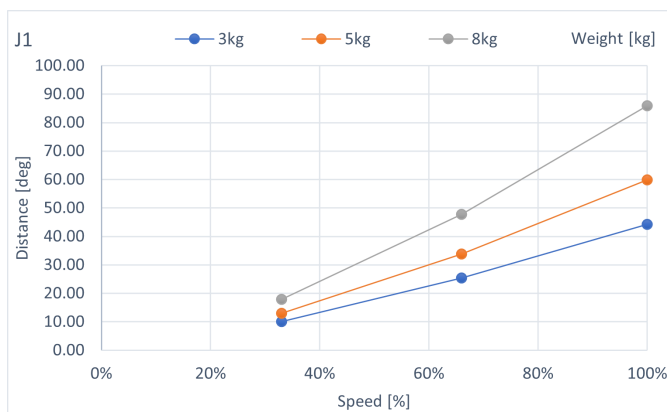
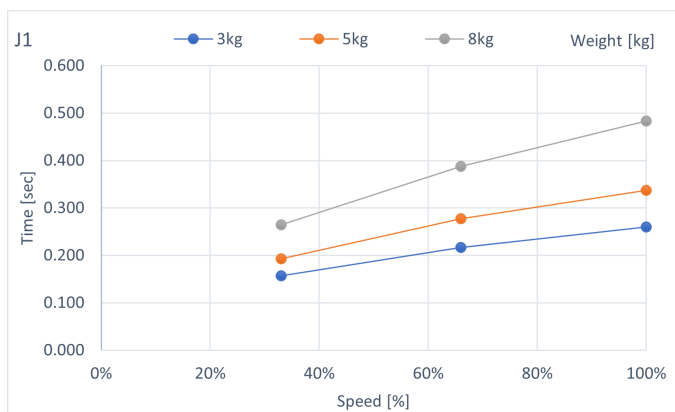

C8-B901***: J2 (Table top mounting, Ceiling mounting)

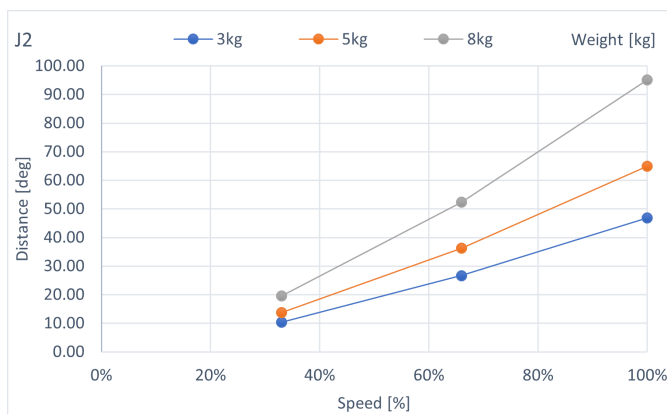
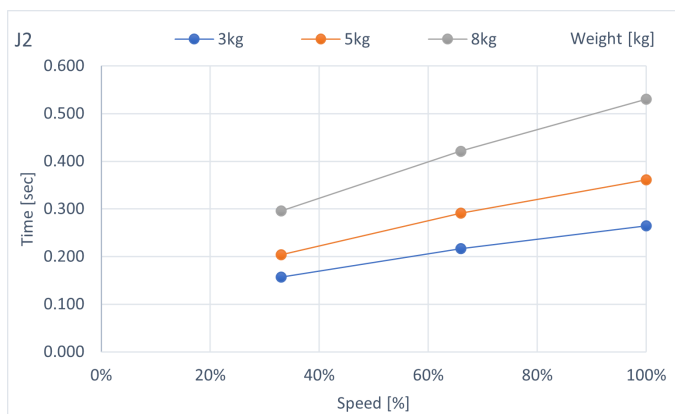

C8-B901***: J3 (Table top mounting, Ceiling mounting)

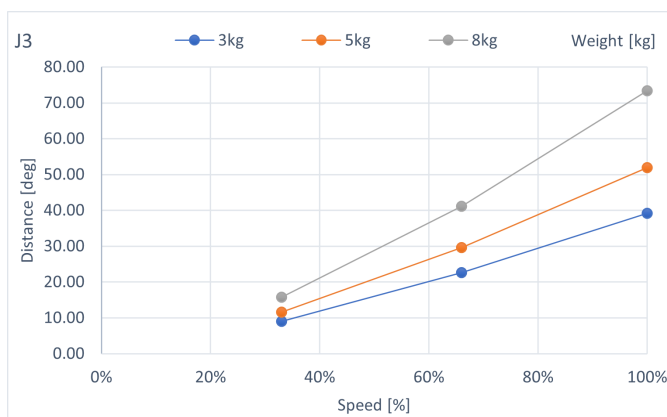
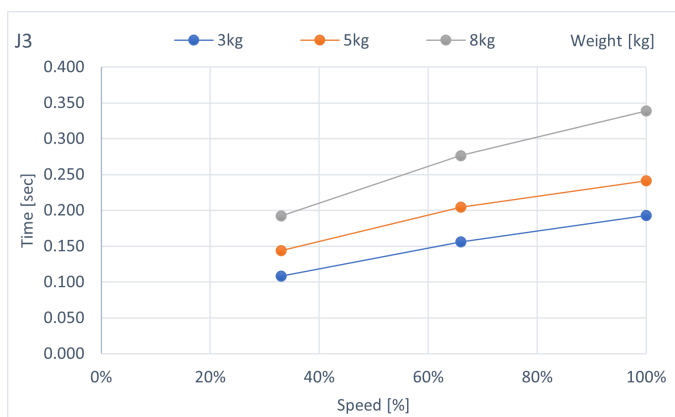

C8-B901***: J4 (Table top mounting, Ceiling mounting)

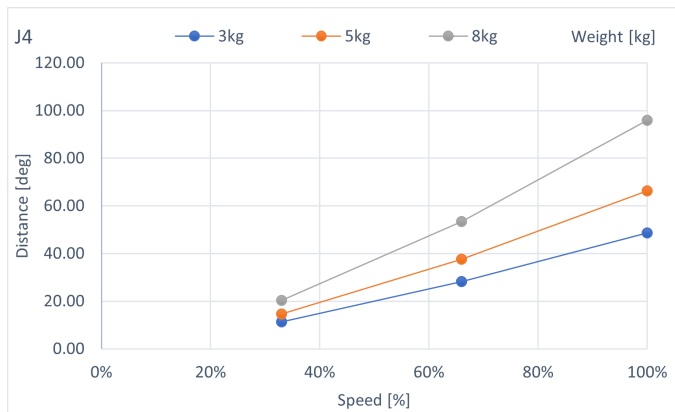
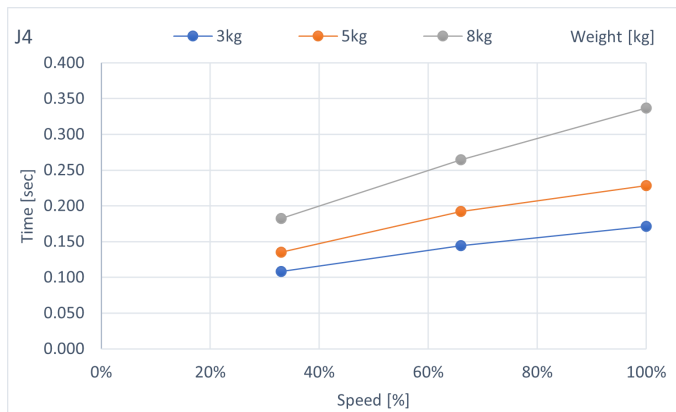

C8-B901***: J5 (Table top mounting, Ceiling mounting)

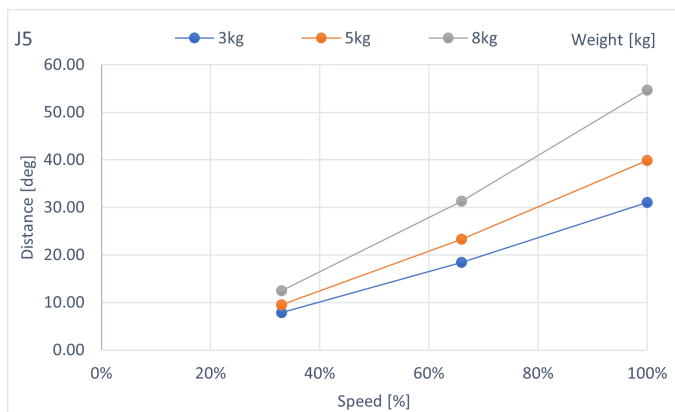
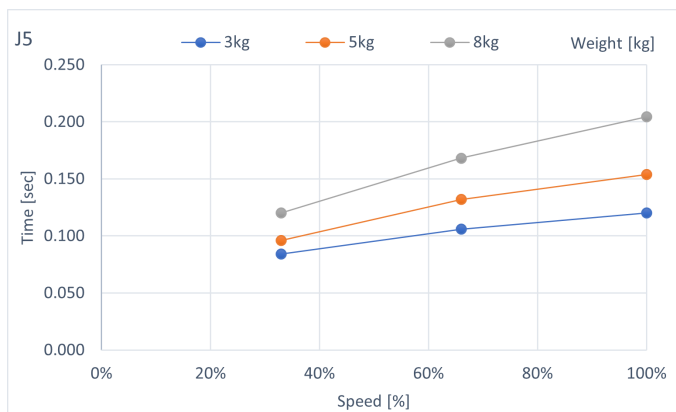

C8-B901***: J6 (Table top mounting, Ceiling mounting)

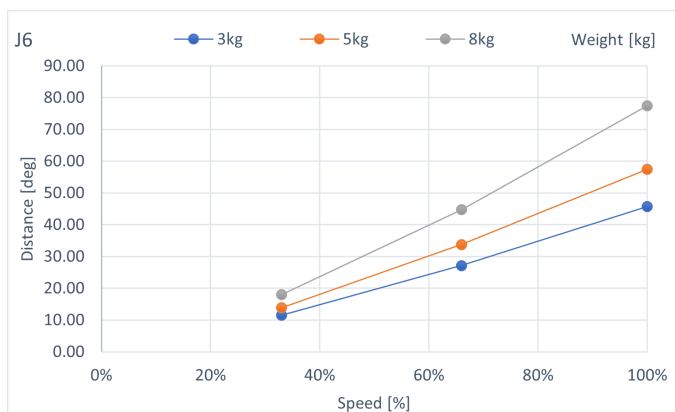
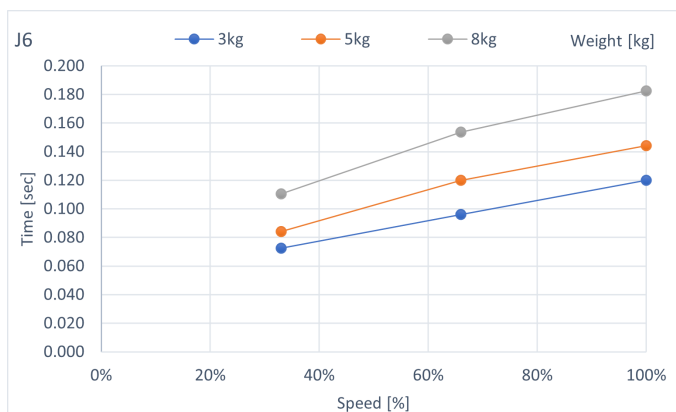

C8-B901***: J1 (Wall mounting)

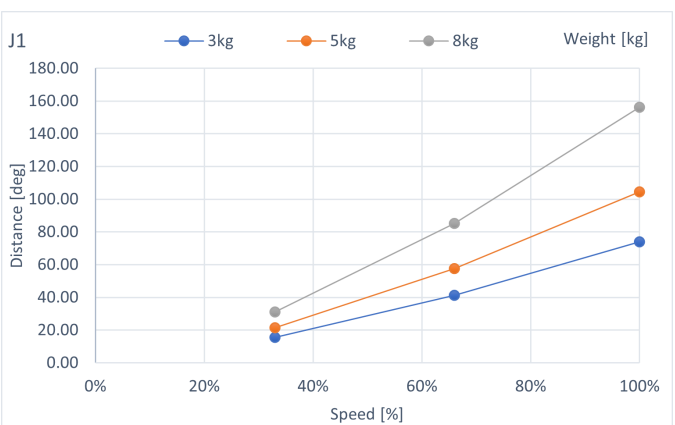
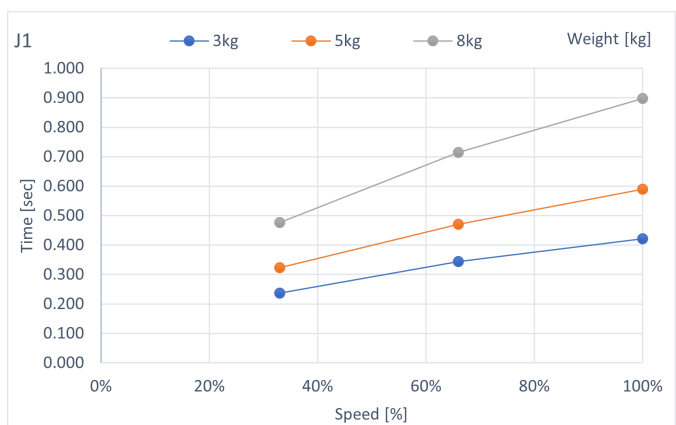

C8-B901***: J2 (Wall mounting)

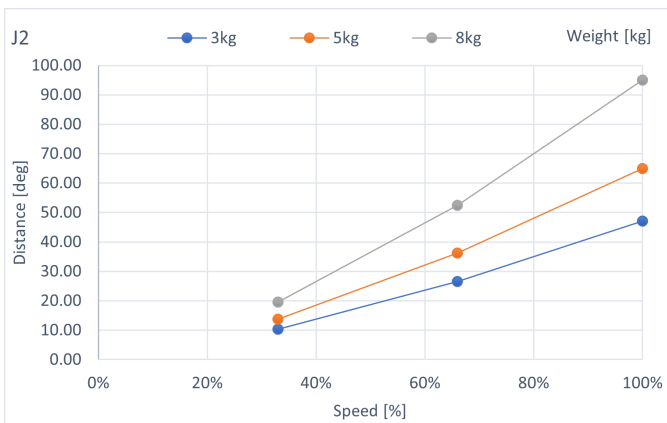
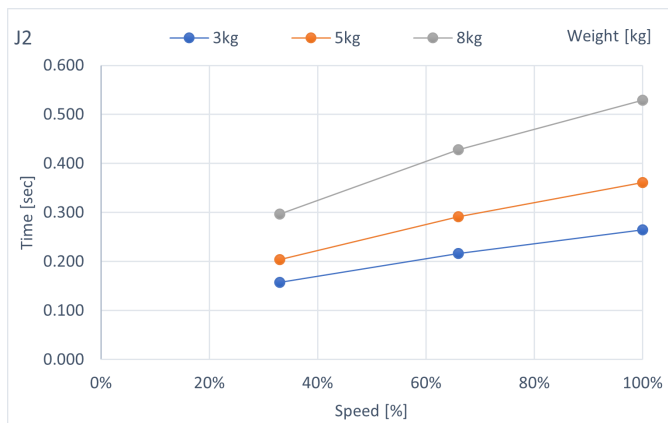

C8-B901***: J3 (Wall mounting)

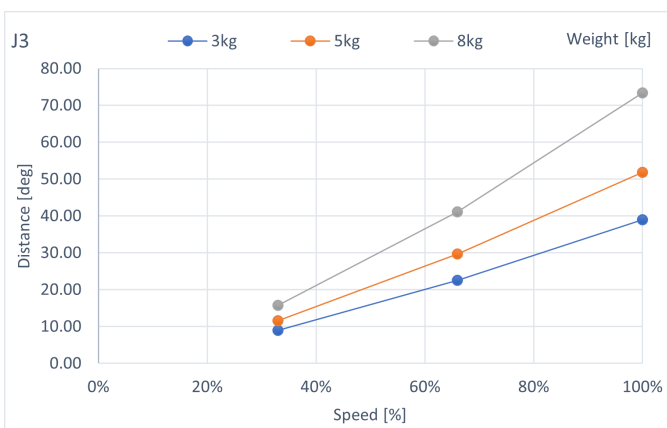
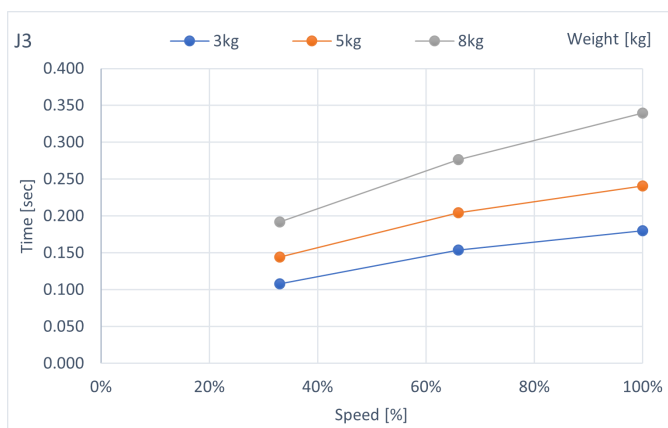

C8-B901***: J4 (Wall mounting)

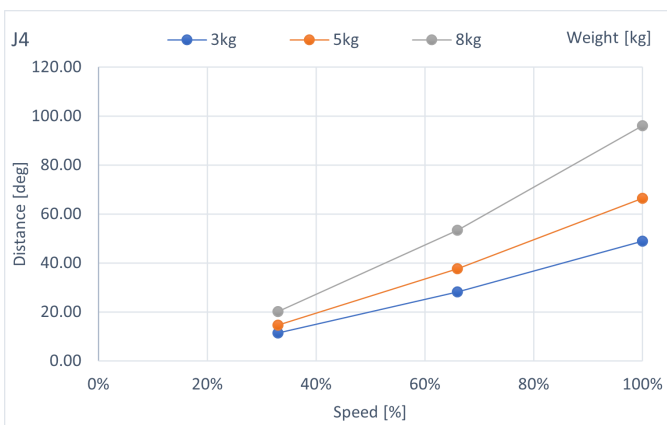
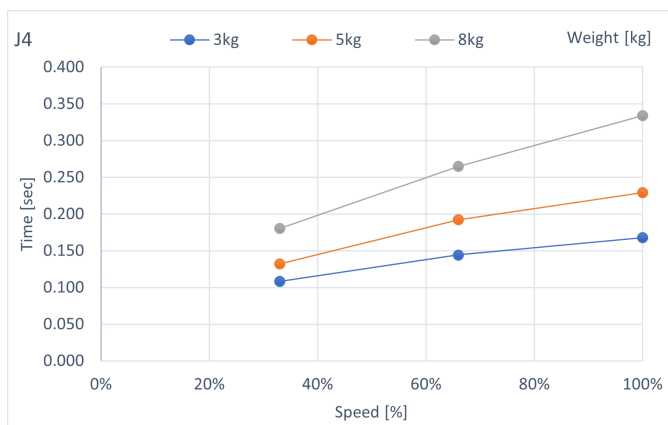

C8-B901***: J5 (Wall mounting)

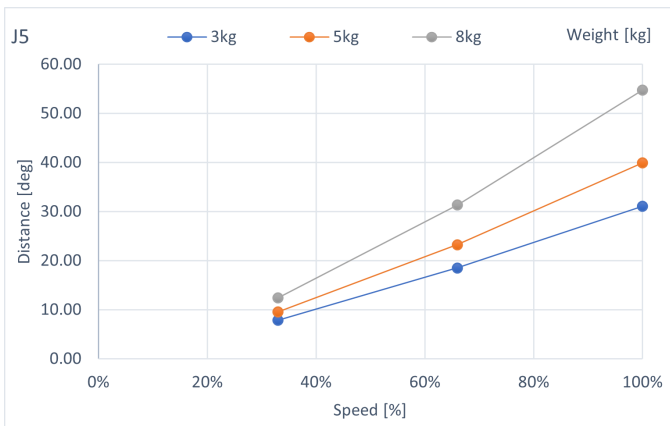
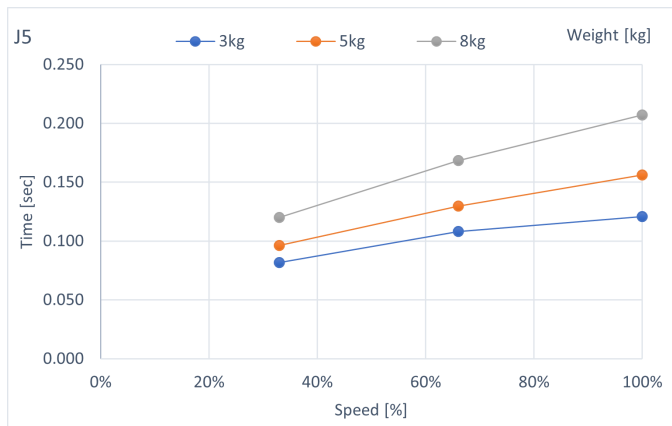

C8-B901***: J6 (Wall mounting)

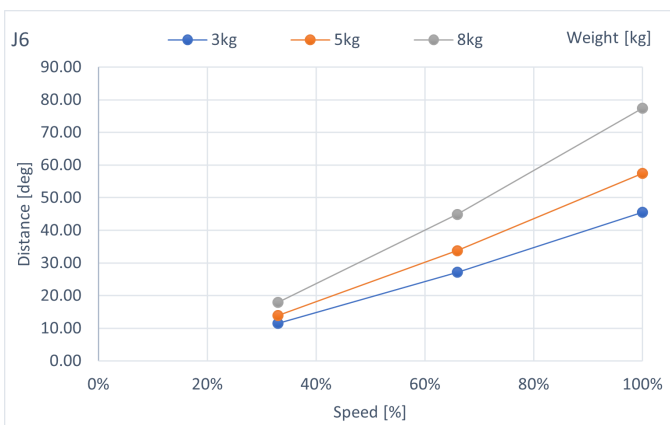
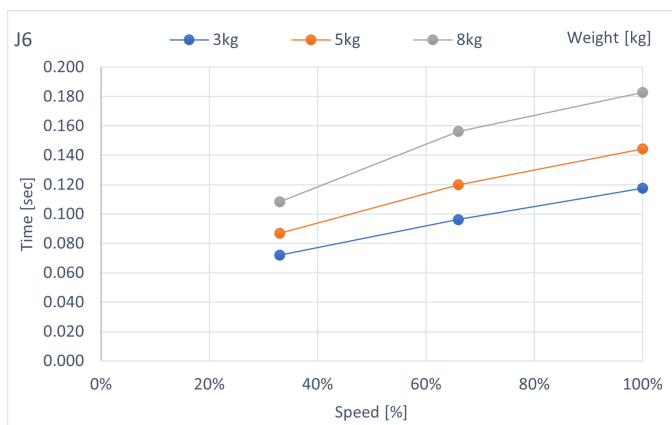

C8-B1401***: J1 (Table top mounting, Ceiling mounting)

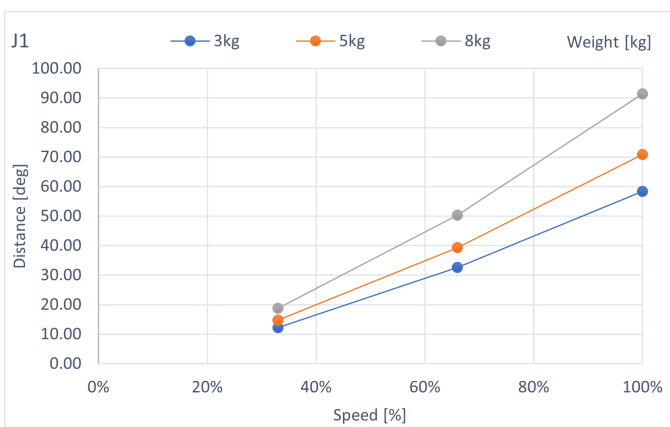
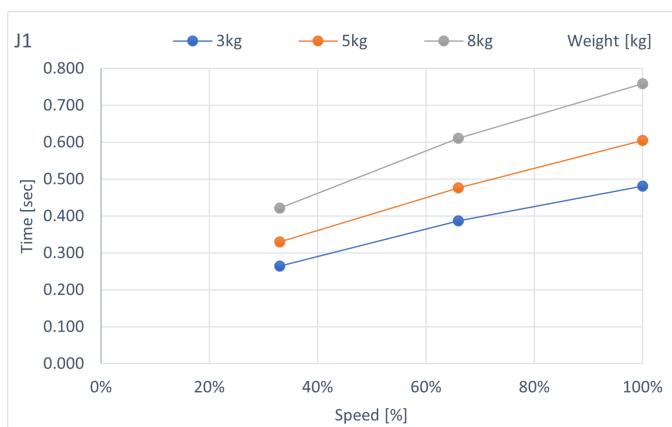

C8-B1401***: J2 (Table top mounting, Ceiling mounting)

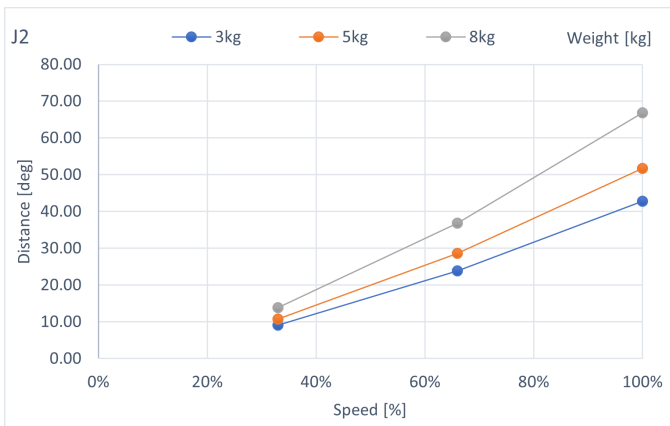
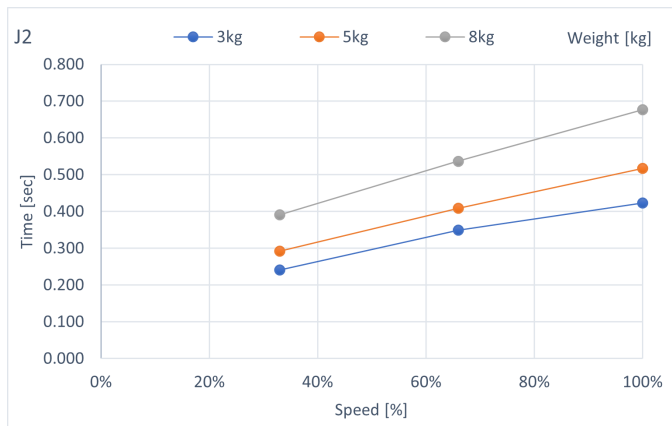

C8-B1401***: J3 (Table top mounting, Ceiling mounting)

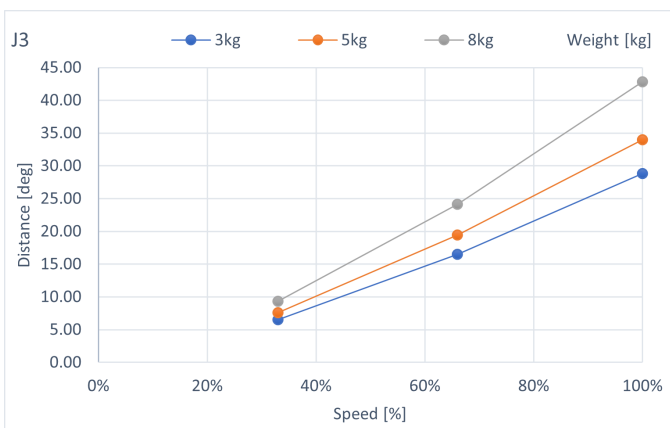
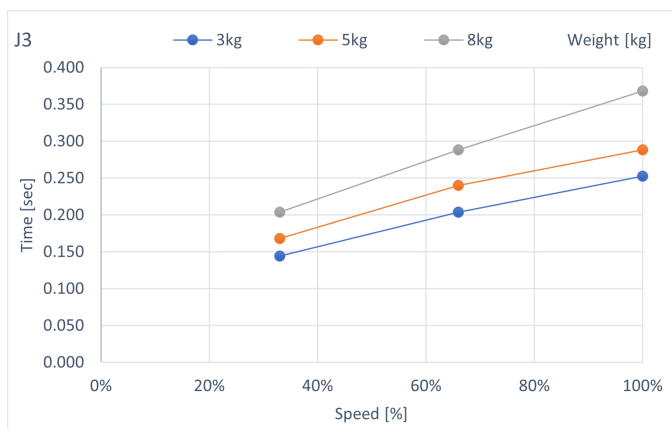

C8-B1401***: J4 (Table top mounting, Ceiling mounting)

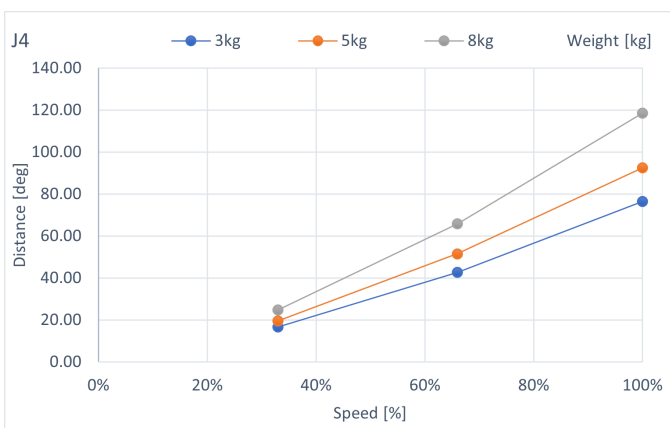
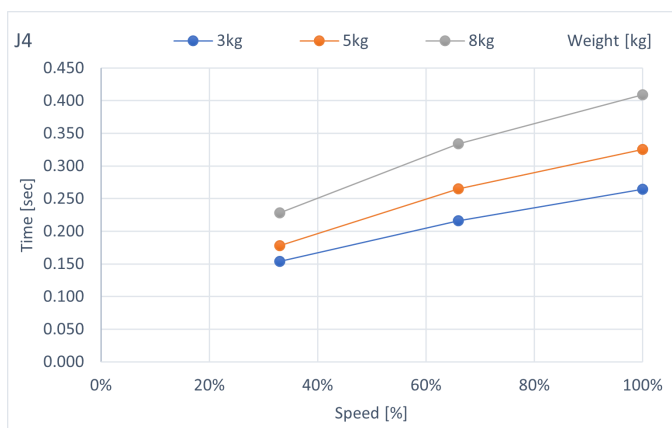

C8-B1401***: J5 (Table top mounting, Ceiling mounting)

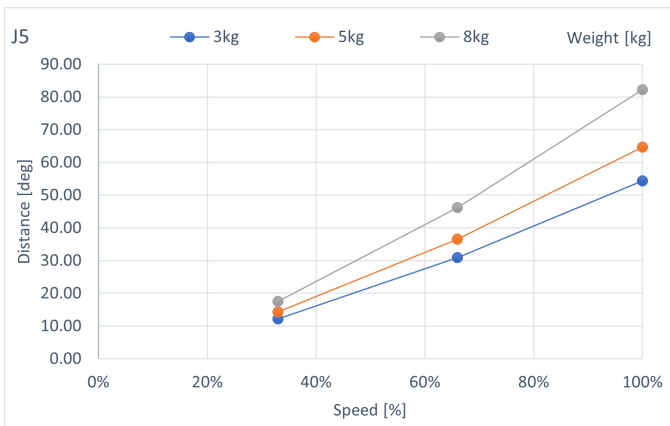
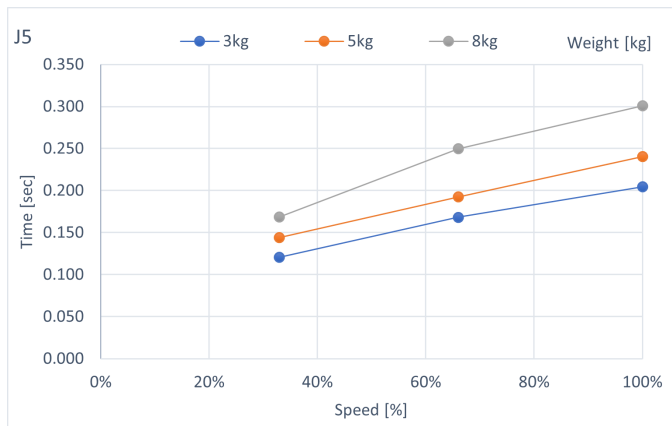

C8-B1401***: J6 (Table top mounting, Ceiling mounting)

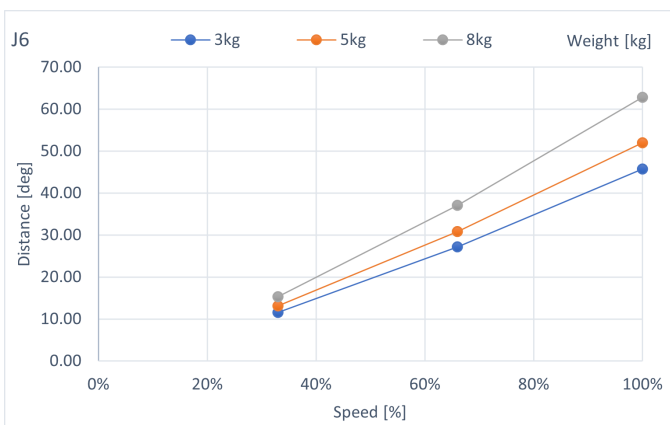
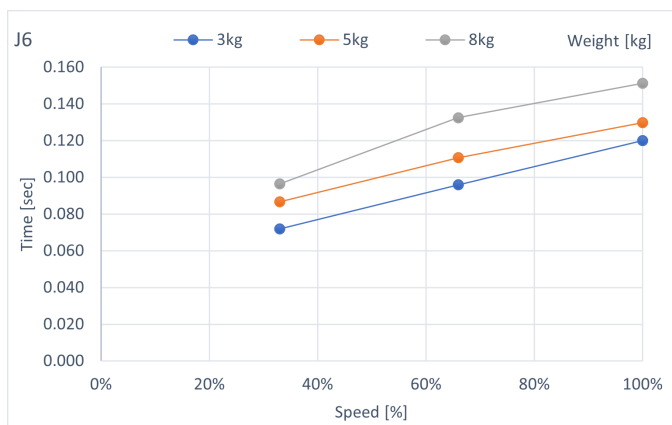

C8-B1401***: J1 (Wall mounting)

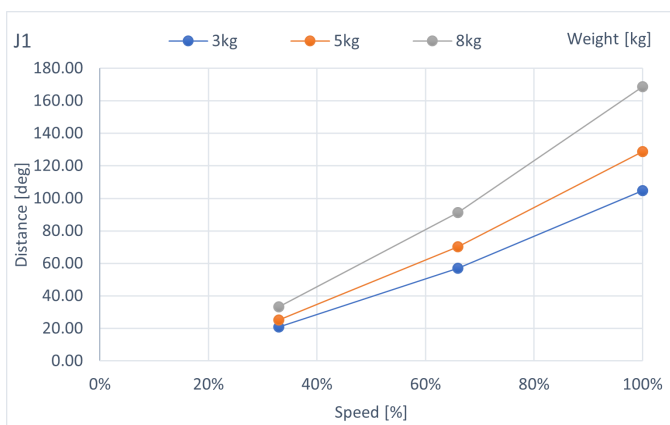
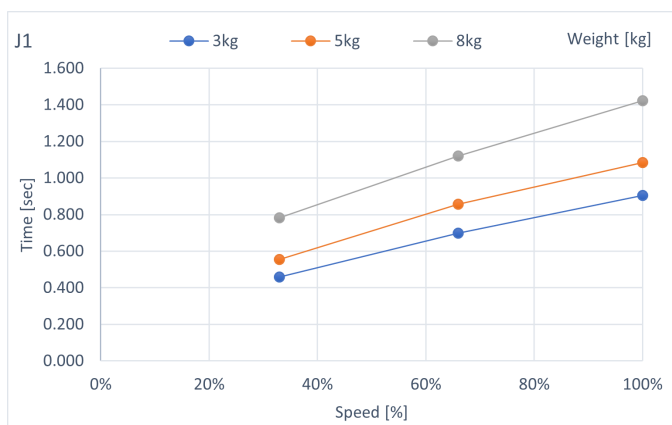

C8-B1401***: J2 (Wall mounting)

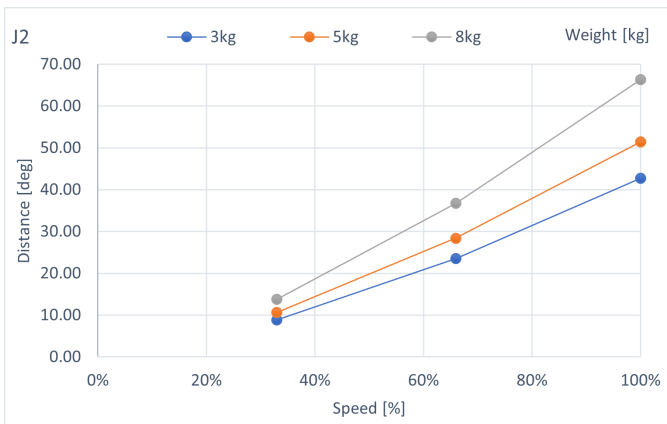
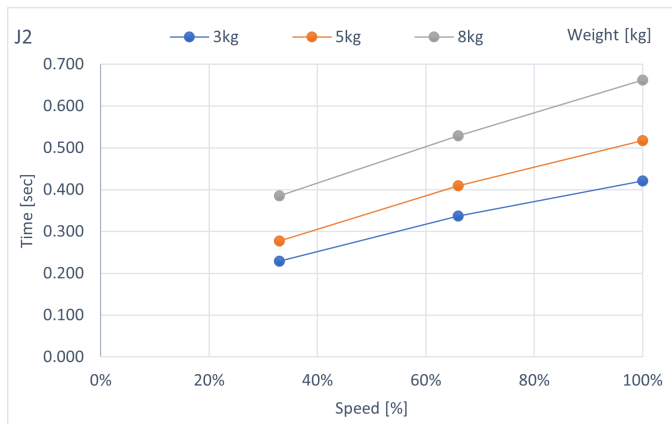

C8-B1401***: J3 (Wall mounting)

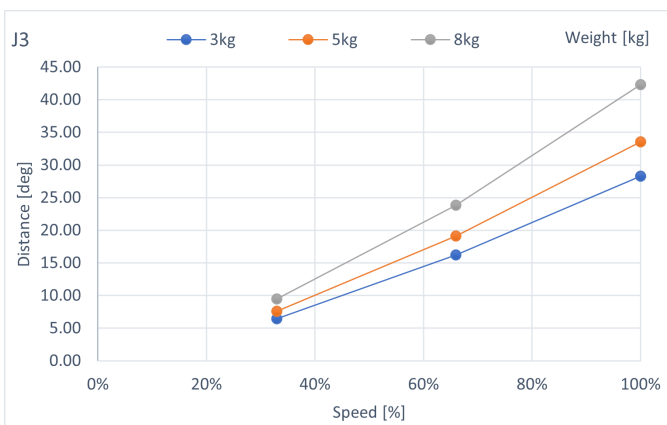
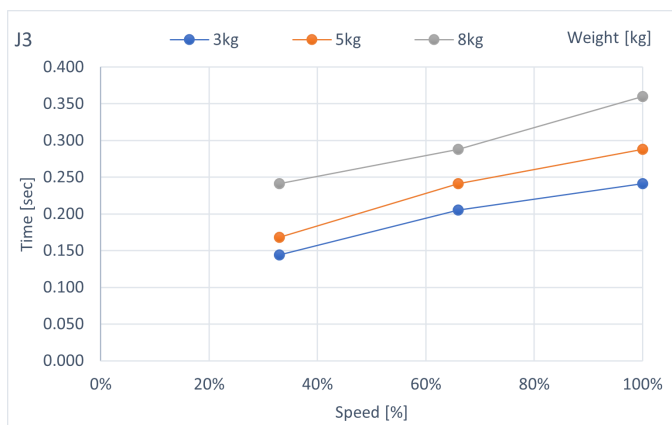

C8-B1401***: J4 (Wall mounting)

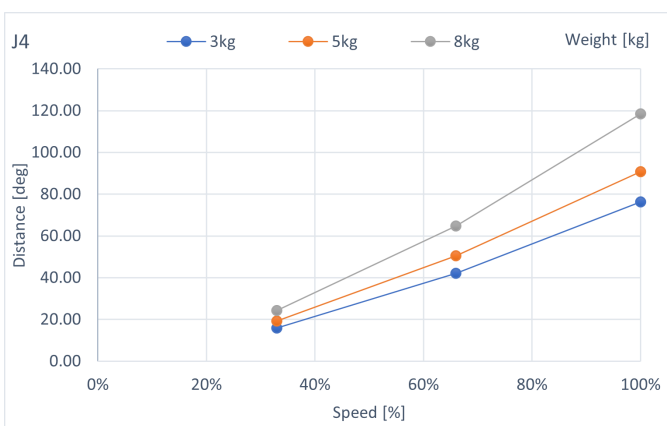
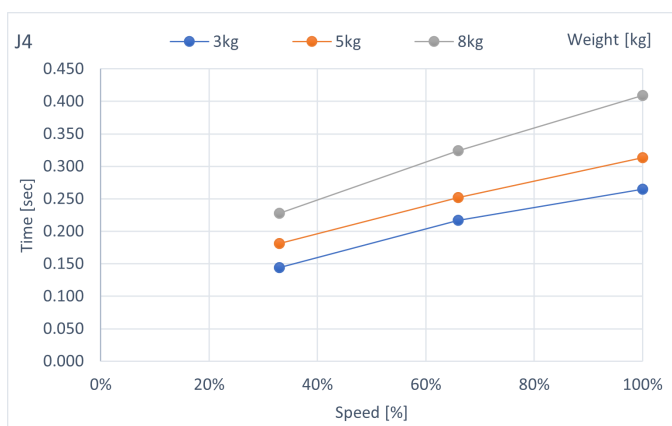

C8-B1401***: J5 (Wall mounting)

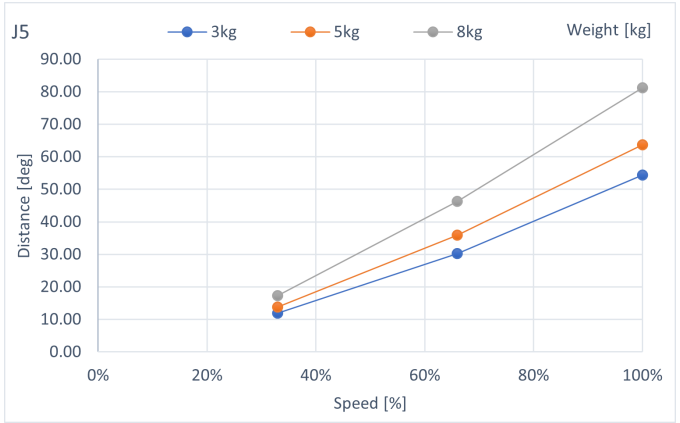
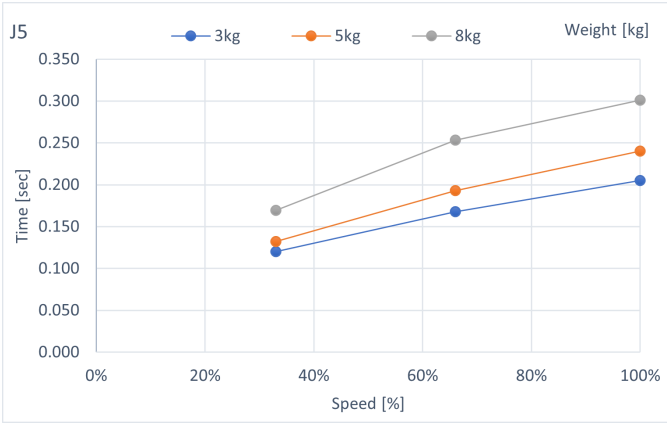

C8-B1401***: J6 (Wall mounting)

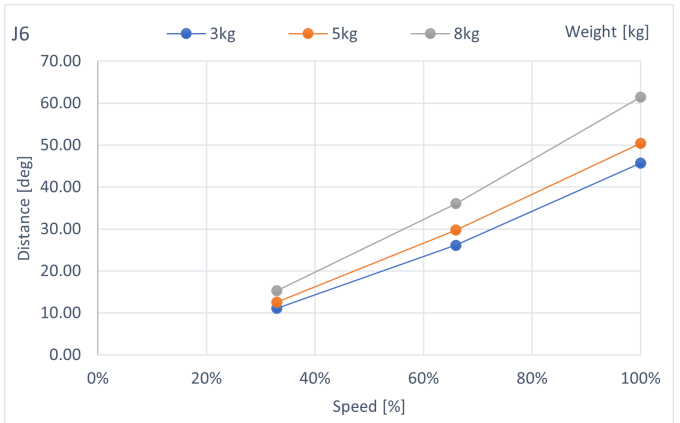
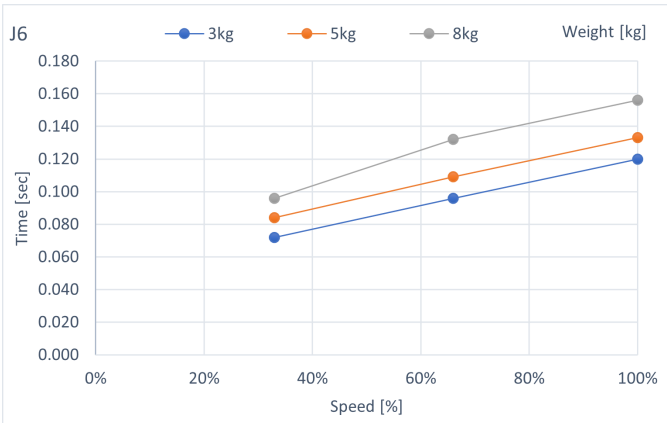

6.3.3 C12-B Stopping Time and Stopping Distance When Safeguard is Open

C12-B1401**: J1 (Table top mounting)

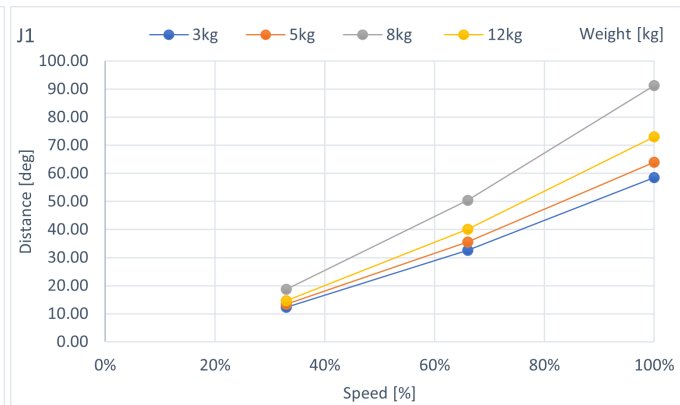
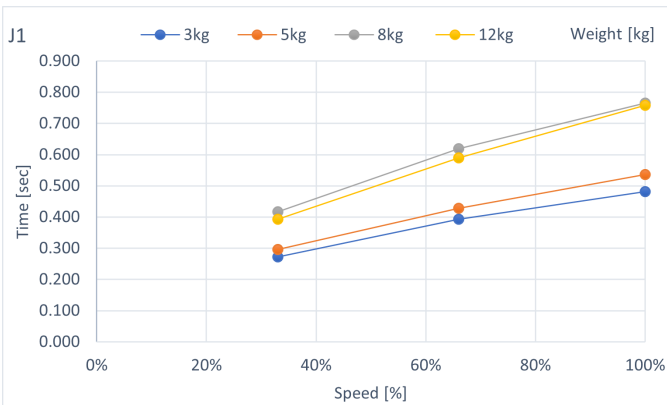

C12-B1401**: J2 (Table top mounting)

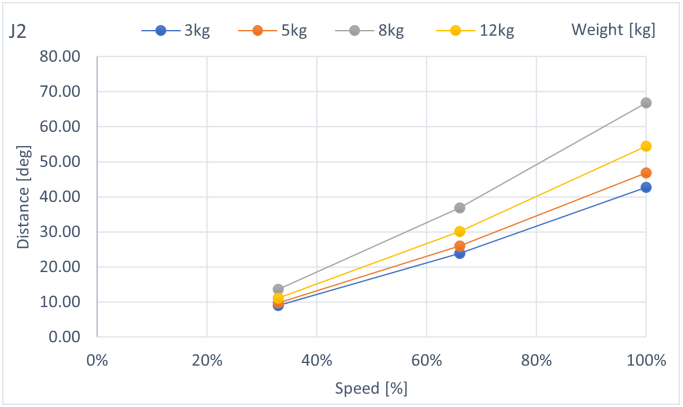
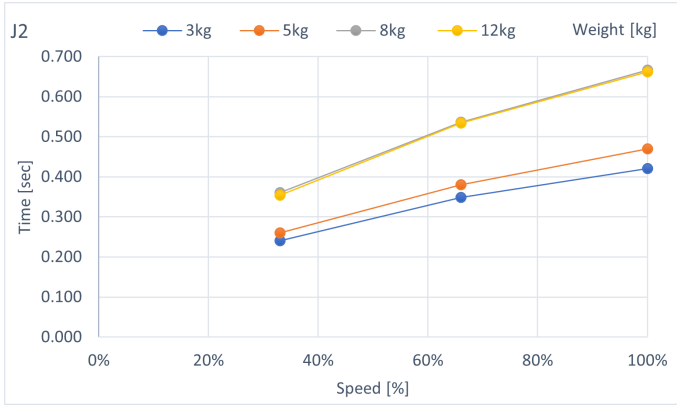

C12-B1401**: J3 (Table top mounting)

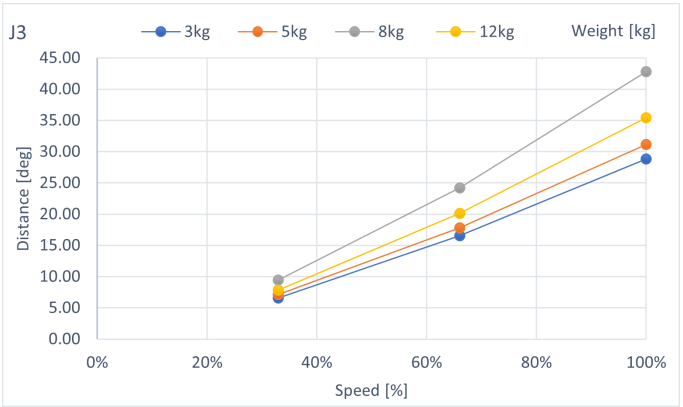
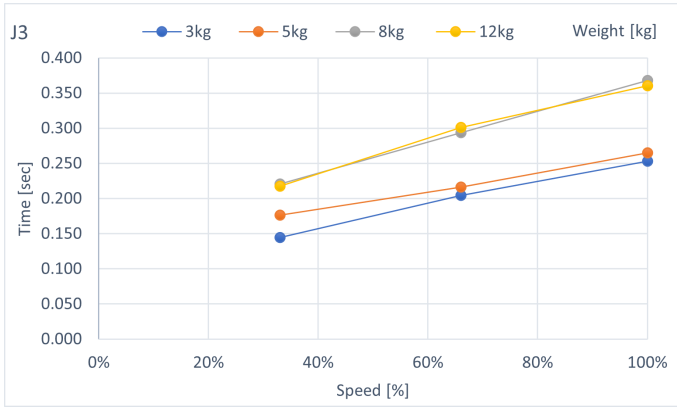

C12-B1401**: J4 (Table top mounting)

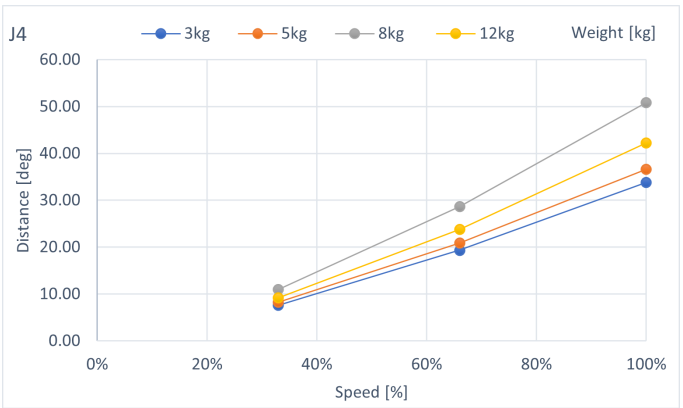
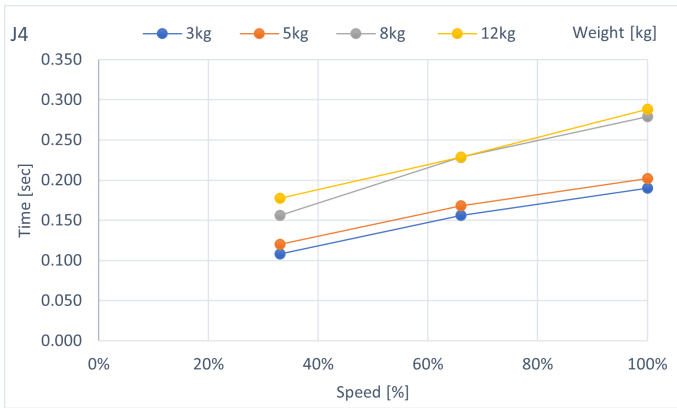

C12-B1401**: J5 (Table top mounting)

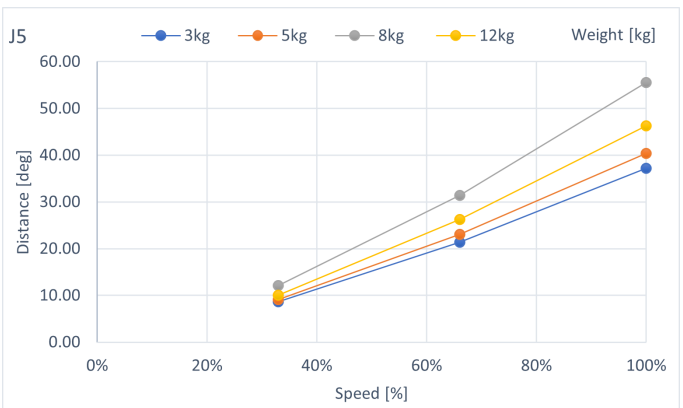
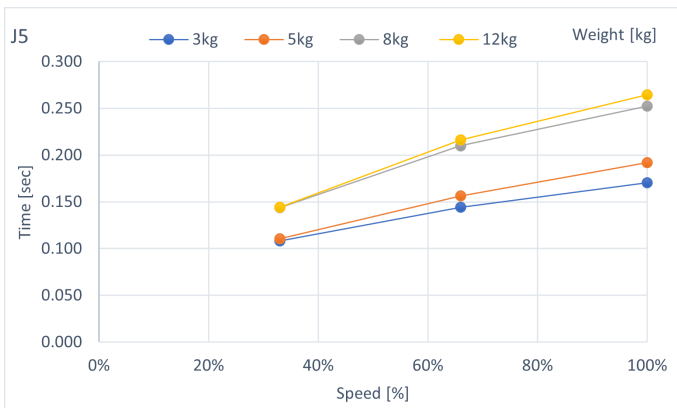

C12-B1401**: J6 (Table top mounting)

