

EPSON

Industrial Robot: 6-Axis Robots

C series

Manual

Rev.8

ENM247R6556F

Original instructions

Industrial Robot: 6-Axis Robots

C series Manual

Rev.8

©Seiko Epson Corporation 2021-2024

FOREWORD

Thank you for purchasing our robot products.

This manual contains the information necessary for the correct use of the manipulator.

Please carefully read this manual and other related manuals before installing the robot system.

Keep this manual handy for easy access at all times.

The robot system and its optional parts are shipped to our customers only after being subjected to the strictest quality controls, tests, and inspections to certify its compliance with our high performance standards. Please note that the basic performance of the product will not be exhibited if our robot system is used outside of the usage conditions and product specifications described in the manuals.

This manual describes possible dangers and consequences that we can foresee. Be sure to comply with safety precautions on this manual to use our robot system safely and correctly.

TRADEMARKS

Microsoft, Windows, and Windows logo are either registered trademarks or trademarks of Microsoft Corporation in the United States and/or other countries. Other brand and product names are trademarks or registered trademarks of the respective holders.

NOTICE

No part of this manual may be copied or reproduced without authorization.

The contents of this manual are subject to change without notice.

Please notify us if you should find any errors in this manual or if you have any comments regarding its contents.

MANUFACTURER

SEIKO EPSON CORPORATION

CONTACT INFORMATION

Contact information is described in “SUPPLIERS” in the first pages of the following manual:

Robot System Safety Manual Read this manual first

DISPOSAL

When disposing this product, dispose in accordance with the laws and regulations of each country.

Regarding battery disposal

The battery removal/replacement procedure is described in the following manuals:
Maintenance Manual

For European Union customers only



The crossed out wheeled bin label that can be found on your product indicates that this product and incorporated batteries should not be disposed of via the normal household waste stream. To prevent possible harm to the environment or human health please separate this product and its batteries from other waste streams to ensure that it can be recycled in an environmentally sound manner. For more details on available collection facilities please contact your local government office or the retailer where you purchased this product. Use of the chemical symbols Pb, Cd or Hg indicates if these metals are used in the battery.

NOTE



This information only applies to customers in the European Union, according to Directive 2006/66/EC OF THE EUROPEAN PARLIAMENT AND OF THE COUNCIL OF 6 September 2006 on batteries and accumulators and waste batteries and accumulators and repealing Directive 91/157/EEC and legislation transposing and implementing it into the various national legal systems, and to customers in countries in Europe, Middle East and Africa (EMEA) where they have implemented equivalent regulations.

For other countries, please contact your local government to investigate the possibility of recycling your product.

For Users in Taiwan region



Please separate used batteries from other waste streams to ensure that it can be recycled in an environmentally sound manner. For more details on available collection facilities please contact your local government office or the retailer where you purchased this product.

Before Reading This Manual

This section describes what you should know before reading this manual.

Structure of Control System

C series Manipulators can be used with the following combinations of Controllers and software.

C4 series

Controller : RC700, RC700-A
Software : EPSON RC+ 7.0, Epson RC+ 8.0

C8 series

Controller : RC700-A
Software : EPSON RC+ 7.0 Ver.7.1.3 or later, Epson RC+ 8.0 (C8XL)
EPSON RC+ 7.0 Ver.7.1.4 or later, Epson RC+ 8.0 (C8, C8L)
EPSON RC+ 7.0 Ver.7.2.0 or later, Epson RC+ 8.0 (wall

mounting)

C12 series

Controller : RC700-A
Software : EPSON RC+ 7.0 Ver.7.4.6 or later, Epson RC+ 8.0

Setting by Software

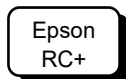

This manual contains setup procedures using the software.
Those sections are indicated by the symbol on the left.

Turning ON/OFF Controller

When you see the instruction “Turn ON/OFF the Controller” in this manual, be sure to turn ON/OFF all the hardware components.

Photos and Illustrations Used in This Manual

The appearance of some parts may differ from those on an actual product depending on when it was shipped or the specifications. The procedures themselves, however, are accurate.

The Manuals of This Product

The following are typical manual types for this product and an outline of the descriptions.

Safety Manual (book, PDF)

This manual contains safety information for all people who handle this product. The manual also describes the process from unpacking to operation and the manual you should look at next.

Read this manual first.

- Safety precautions regarding robot system and residual risk
- Declaration of conformity
- Training
- Flow from unpacking to operation

RC700 series Manual (PDF)

This manual explains the installation of the entire robot system and the specifications and functions of the controller. The manual is primarily intended for people who design robot systems.

- The installation procedure of the robot system (specific details from unpacking to operation)
- Daily inspection of the controller
- Controller specifications and basic functions

C series Manual (PDF)

This manual describes the specifications and functions of the Manipulator. The manual is primarily intended for people who design robot systems.

- Technical information, functions, specifications, etc. required for the Manipulator installation and design
- Daily inspection of the Manipulator

Status Code/Error Code List (PDF)

This manual contains a list of code numbers displayed on the controller and messages displayed in the software message area. The manual is primarily intended for people who design robot systems or do programming.

RC700 series Maintenance Manual (PDF)

C series Maintenance Manual (PDF)

This manual describes the details of maintenance etc. The manual is intended for people who perform maintenance.

- Daily inspection
- Replacement and repair of maintenance parts
- The method of firmware update and controller setting backup etc.

Epson RC+ User's Guide (PDF)

This manual describes general information about program development software.

Epson RC+ SPEL+ Language Reference (PDF)

This manual describes the robot programming language “SPEL+”.

Other Manual (PDF)

Manuals for each option are available.

C4 Manipulator

1. Safety	3
1.1 Conventions.....	3
1.2 Design and Installation Safety.....	4
1.3 Operation Safety	5
1.4 Emergency Stop.....	6
1.5 Safeguard.....	8
1.6 How to Move Arms with the Electromagnetic Brake.....	9
1.6.1 Moving the Arm using the brake release unit.....	10
1.6.2 Moving the Arm using the software.....	10
1.7 Precaution for Operation in Low Power Status.....	10
1.8 Warning Labels.....	11
1.9 Response for Emergency or Malfunction.....	14
1.9.1 Collision	14
1.9.2 Getting body caught in Manipulator	14
2. Specifications	15
2.1 Model Number.....	15
2.2 Part Names and Motion Range of Each Arm.....	16
2.3 Outer Dimensions.....	17
2.3.1 C4-A601**	17
2.3.2 C4-A901**.....	18
2.4 Standard Motion Range	19
2.4.1 C4-A601**.....	19
2.4.2 C4-A901**	20
2.5 Specifications	22
2.5.1 Specifications Table.....	22
2.5.2 Option	22
2.6 How to Set the Model.....	22
3. Environment and Installation	23
3.1 Environmental Conditions	23
3.2 Unpacking, Transportation, and Relocation.....	25
3.3 Mounting Dimensions.....	29
3.4 Installation	30
3.5 Connecting the Cables.....	33
3.6 User Wires and Pneumatic Tubes.....	34
3.7 Checking the Basic orientation.....	35
4. End Effectors	36
4.1 Attaching an End Effector.....	36
4.2 Attaching Camera and Air Valves.....	37
4.3 WEIGHT and INERTIA Settings.....	39
4.3.1 WEIGHT setting.....	41

4.3.2	INERTIA setting.....	46
4.4	Precautions for Auto Acceleration/Deceleration	51
5. Motion Range		52
5.1	Motion Range Setting by Pulse Range (for All Arms).....	53
5.1.1	Max. Pulse Range of Arm #1	54
5.1.2	Max. Pulse Range of Arm #2	55
5.1.3	Max. Pulse Range of Arm #3	55
5.1.4	Max. Pulse Range of Arm #4	56
5.1.5	Max. Pulse Range of Arm #5	57
5.1.6	Max. Pulse Range of Arm #6	57
5.2	Motion Range Setting by Mechanical Stops.....	58
5.2.1	Motion Range Setting of Arm #1	58
5.2.2	Motion Range Setting of Arm #2	59
5.2.3	Motion Range Setting of Arm #3.....	59
5.3	Restriction of Manipulator Operation by Joint Angle Combination	60
5.4	Coordinate System.....	63
5.5	Changing the Robot	64
5.6	Setting the Cartesian (Rectangular) Range in the XY Coordinate System of the Manipulator	65
6. Options		66
6.1	Brake Release Unit	66
	Power Cable.....	67
	Mount the brake release unit	68
	Remove the brake release unit.....	69
	How to use the brake release unit	69
6.2	Camera Plate Unit.....	70
6.3	PS Compatible Plate (Tool Adapter)	73
6.4	Base Side Angled Fittings	75
6.5	Base Side Fittings	77
6.6	PS Compatible Plate (Base Adapter).....	80
6.7	Adjustable Mechanical Stop (Joint #2: only C4-A901**)	81

C8 Manipulator

1. Safety	85
1.1 Conventions.....	85
1.2 Design and Installation Safety.....	86
1.3 Operation Safety	87
1.4 Emergency Stop.....	88
1.5 Safeguard.....	90
1.6 How to Move Arms with the Electromagnetic Brake.....	91
1.6.1 Moving the Arm using the brake release unit.....	92
1.6.2 Moving the Arm using the software.....	92
1.7 Precaution for Operation in Low Power Status.....	92
1.8 Warning Labels.....	93
1.9 Response for Emergency or Malfunction.....	96
1.9.1 Collision	96
1.9.2 Getting body caught in Manipulator	96
2. Specifications	97
2.1 Model Number.....	97
2.2 Part Names and Motion Range of Each Arm.....	98
2.3 Outer Dimensions.....	100
2.3.1 C8-A701*** (C8).....	100
2.3.2 C8-A901*** (C8L).....	101
2.3.3 C8-A1401*** (C8XL).....	102
2.4 Standard Motion Range	103
2.4.1 C8-A701*** (C8).....	103
2.4.2 C8-A901*** (C8L).....	104
2.4.3 C8-A1401*** (C8XL).....	105
2.5 Specifications	106
2.5.1 Specifications Table.....	106
2.5.2 Option	106
2.6 How to Set the Model.....	107
3. Environment and Installation	108
3.1 Environmental Conditions	108
3.2 Unpacking, Transportation, and Relocation.....	110
3.3 Mounting Dimensions.....	114
3.3.1 Cable Backward Model	114
3.3.2 Cable Downward Model	116
3.4 Installation	117
3.5 Connecting the Cables.....	120
3.6 User Wires and Pneumatic Tubes.....	122
Electrical wires	123
Pneumatic tubes	124
3.7 Checking the Basic orientation.....	125

4. End Effectors	126
4.1 Attaching an End Effector	126
4.2 Attaching Camera and Air Valves	126
4.3 WEIGHT and INERTIA Settings.....	128
4.3.1 WEIGHT setting	130
4.3.2 INERTIA setting.....	134
4.4 Precautions for Auto Acceleration/Deceleration	139
5. Motion Range	140
5.1 Motion Range Setting by Pulse Range (for Each Joint).....	140
5.1.1 Max. Pulse Range of Joint #1	141
5.1.2 Max. Pulse Range of Joint #2	141
5.1.3 Max. Pulse Range of Joint #3	142
5.1.4 Max. Pulse Range of Joint #4	142
5.1.5 Max. Pulse Range of Joint #5	143
5.1.6 Max. Pulse Range of Joint #6	143
5.2 Motion Range Setting by Mechanical Stops.....	144
5.2.1 Motion Range Setting of Joint #1.....	144
5.2.2 Motion Range Setting of Joint #2.....	145
5.2.3 Motion Range Setting of Joint #3.....	147
5.3 Restriction of Manipulator Operation by Joint Angle Combination	147
5.4 Coordinate System.....	151
5.5 Changing the Robot	152
5.6 Setting the Cartesian (Rectangular) Range in the XY Coordinate System of the Manipulator	153
6. Options	154
6.1 Brake Release Unit	154
Power Cable.....	155
Mount the brake release unit	157
Remove the brake release unit.....	158
How to use the brake release unit	158
6.2 Camera Plate Unit.....	159
6.3 Tool Adapter (ISO Flange)	161
6.4 Adjustable Mechanical Stops.....	163
6.5 User Wires and Pneumatic Tubes	164

C12 Manipulator

1. Safety	167
1.1 Conventions.....	167
1.2 Design and Installation Safety.....	168
1.3 Operation Safety	169
1.4 Emergency Stop.....	170
1.5 Safeguard.....	172
1.6 How to Move Arms with the Electromagnetic Brake.....	173
1.6.1 Moving the Arm using the brake release unit.....	174
1.6.2 Moving the Arm using the software.....	174
1.7 Precaution for Operation in Low Power Status.....	174
1.8 Warning Labels.....	175
1.9 Response for Emergency or Malfunction.....	178
1.9.1 Collision	178
1.9.2 Getting body caught in Manipulator	178
2. Specifications	179
2.1 Model Number.....	179
2.2 Part Names and Motion Range of Each Arm.....	180
2.3 Outer Dimensions.....	182
2.4 Standard Motion Range	183
2.5 Specifications	184
2.5.1 Specifications Table.....	184
2.5.2 Option	184
2.6 How to Set the Model.....	185
3. Environment and Installation	186
3.1 Environmental Conditions	186
3.2 Unpacking, Transportation, and Relocation.....	187
3.3 Mounting Dimensions.....	191
3.3.1 Cable Backward Model	191
3.3.2 Cable Downward Model	192
3.4 Installation	193
3.5 Connecting the Cables.....	196
3.6 User Wires and Pneumatic Tubes.....	198
Electrical wires	199
Pneumatic tubes	199
3.7 Checking the Basic orientation.....	200
4. End Effectors	201
4.1 Attaching an End Effector.....	201
4.2 Attaching Camera and Air Valves.....	202
4.3 WEIGHT and INERTIA Settings.....	203
4.3.1 WEIGHT setting.....	205

4.3.2	INERTIA setting.....	208
4.4	Precautions for Auto Acceleration/Deceleration	213
5. Motion Range		214
5.1	Motion Range Setting by Pulse Range (for Each Joint).....	214
5.1.1	Max. Pulse Range of Joint #1	215
5.1.2	Max. Pulse Range of Joint #2	215
5.1.3	Max. Pulse Range of Joint #3	216
5.1.4	Max. Pulse Range of Joint #4	216
5.1.5	Max. Pulse Range of Joint #5	217
5.1.6	Max. Pulse Range of Joint #6	217
5.2	Motion Range Setting by Mechanical Stops.....	218
5.2.1	Motion Range Setting of Joint #1.....	218
5.2.2	Motion Range Setting of Joint #2.....	219
5.2.3	Motion Range Setting of Joint #3.....	219
5.3	Restriction of Manipulator Operation by Joint Angle Combination	220
5.4	Coordinate System.....	221
5.5	Changing the Robot	222
5.6	Setting the Cartesian (Rectangular) Range in the XY Coordinate System of the Manipulator	223
6. Options		224
6.1	Brake Release Unit	224
	Power Cable.....	225
	Mount the brake release unit	227
	Remove the brake release unit.....	228
	How to use the brake release unit	229
6.2	Camera Plate Unit.....	230
6.3	Tool Adapter (ISO Flange)	233
6.4	Adjustable Mechanical Stops.....	234
6.5	User Wires and Pneumatic Tubes	235

Regular Inspection

1. Regular Inspection for C4 Manipulator	239
1.1 Inspection	239
1.1.1 Schedule for Inspection.....	239
1.1.2 Inspection Point.....	240
1.2 Overhaul (Parts Replacement).....	242
1.3 Greasing	242
1.4 Tightening Hexagon Socket Head Bolts	242
2. Regular Inspection for C8 Manipulator	243
2.1 Inspection	243
2.1.1 Schedule for Inspection.....	243
2.1.2 Inspection Point.....	244
2.2 Overhaul (Parts Replacement).....	246
2.3 Greasing	246
2.4 Tightening Hexagon Socket Head Bolts	246
3. Regular Inspection for C12 Manipulator	247
3.1 Inspection	247
3.1.1 Schedule for Inspection.....	247
3.1.2 Inspection Point.....	248
3.2 Overhaul (Parts Replacement).....	250
3.3 Greasing	250
3.4 Tightening Hexagon Socket Head Bolts	250

Appendix

Appendix A: Specifications	253
C4 Specifications	253
C8 Specifications	257
C12 Specifications	262
Appendix B: Stopping time and Stopping distance in Emergency	266
C4 Stopping time and Stopping distance in Emergency	267
C8 Stopping time and Stopping distance in Emergency	271
C12 Stopping time and Stopping distance in Emergency	283
Appendix C: Stopping time and Stopping distance When Safeguard Is Opened	285
C4 Stopping time and Stopping distance When Safeguard Is Opened	286
C8 Stopping time and Stopping distance When Safeguard Is Opened	290
C12 Stopping time and Stopping distance When Safeguard Is Opened	302

C4 Manipulator

This volume contains information for setup and operation of the Manipulators.
Please read this volume thoroughly before setting up and operating the Manipulators.

1. Safety



Unpacking and transportation of the Manipulators and robotic equipment shall be performed by personnel who has taken robot system training held by us and suppliers and should conform to all national and local codes.

Please read this manual and other related manuals before installing the robot system or before connecting cables.

Keep this manual handy for easy access at all times and reread it when you find anything unclear.

1.1 Conventions

Important safety considerations are indicated throughout the manual by the following symbols. Be sure to read the descriptions shown with each symbol.

 WARNING	This symbol indicates that a danger of possible serious injury or death exists if the associated instructions are not followed properly.
 WARNING	This symbol indicates that a danger of possible harm to people caused by electric shock exists if the associated instructions are not followed properly.
 CAUTION	This symbol indicates that a danger of possible harm to people or physical damage to equipment and facilities exists if the associated instructions are not followed properly.

1.2 Design and Installation Safety

This product is intended for transporting and assembling parts in a safely isolated area. Design and installation of robot system shall be performed by personnel who has taken robot system training held by us and suppliers.

To ensure safety, a safeguard must be installed for the robot system. For details on the safeguard, refer to the *Installation and Design Precautions* in the *Safety* chapter of the Epson RC+ User's Guide.



The following items are safety precautions for design personnel:

 <p>WARNING</p>	<ul style="list-style-type: none">■ Personnel who design and/or construct the robot system with this product must read “<i>Safety Manual</i>”. Designing and/or constructing the robot system without understanding the safety requirements is extremely hazardous, and may result in serious bodily injury and/or severe equipment damage to the robot system.■ The Manipulator and the Controller must be used within the environmental conditions described in their respective manuals. This product has been designed and manufactured strictly for use in a normal indoor environment. Using the product in an environment that exceeds the specified environmental conditions may not only shorten the life of the product but may also cause serious safety problems.■ The robot system must be used within the installation requirements described in the manuals. Using the robot system outside of the installation requirements may not only shorten the life of the product but also cause serious safety problems.■ When designing or installing a robot system, wear at least the following protective gear. Working without protective gear may cause serious safety problems.<ul style="list-style-type: none">Work clothes suitable for workHelmetSafety shoes
--	---

Further precautions for installation are described in “3. *Environment and Installation*”. Please read this chapter carefully to understand safe installation procedures before installing the robots and robotic equipment.

1.3 Operation Safety

The following items are safety precautions for qualified Operator personnel:

 WARNING	<ul style="list-style-type: none"> ■ Please carefully read “<i>Safety Manual</i>”. Operating the robot system without understanding the safety precautions is extremely hazardous and may result in serious bodily injury and/or severe equipment damage to the robot system. ■ Do not enter the operating area of the Manipulator while the power to the robot system is turned ON. Entering the operating area with the power ON is extremely hazardous and may cause serious safety problems as the Manipulator may move even if it seems to be stopped. ■ Before operating the robot system, make sure that no one is inside the safeguarded area. The robot system can be operated in the mode for teaching even when someone is inside the safeguarded area. The motion of the Manipulator is always in restricted status (low speeds and low power) to secure the safety of an operator. However, operating the robot system while someone is inside the safeguarded area is extremely hazardous and may result in serious safety problems in case that the Manipulator moves unexpectedly. ■ Immediately press the Emergency Stop switch whenever the Manipulator moves abnormally during operation. Continuing the operation while the Manipulator moves abnormally is extremely hazardous and may result in serious bodily injury and/or severe equipment change to the robot system.
 WARNING	<ul style="list-style-type: none"> ■ Be sure to connect the AC power cable to a power receptacle. DO NOT connect it directly to a factory power source. To shut off power to the robot system, disconnect the power plug from the power source. Performing any work while connecting the AC power cable to a factory power source is extremely hazardous and may result in electric shock and/or malfunction of the robot system. ■ Before performing any replacement procedure, turn OFF the Controller and related equipment, and then disconnect the power plug from the power source. Performing any replacement procedure with the power ON is extremely hazardous and may result in electric shock and/or malfunction of the robot system. ■ Do not connect or disconnect the motor connectors while the power to the robot system is turned ON. Connecting or disconnecting the motor connectors with the power ON is extremely hazardous and may result in serious bodily injury as the Manipulator may move abnormally, and also may result in electric shock and/or malfunction of the robot system.

 CAUTION	<ul style="list-style-type: none"> ■ Whenever possible, only one person should operate the robot system. If it is necessary to operate the robot system with more than one person, ensure that all people involved communicate with each other as to what they are doing and take all necessary safety precautions. ■ If the joints are operated repeatedly with the operating angle less than 5 degrees, they may get damaged early because the bearings are likely to cause oil film shortage in such situation. To prevent early breakdown, move each joint larger than 30 degrees for about once an hour. ■ Oscillation (resonance) may occur continuously in low speed Manipulator motion (Speed: approx. 5 to 20%) depending on combination of Arm orientation and end effector load. Oscillation arises from natural oscillation frequency of the Arm and can be controlled by following measures. <ul style="list-style-type: none"> Changing Manipulator speed Changing the teach points Changing the end effector load
--	---

1.4 Emergency Stop

If the Manipulator moves abnormally during operation, immediately press the Emergency Stop switch. Pressing the Emergency Stop switch immediately changes the Manipulator to deceleration motion and stops it at the maximum deceleration speed.

Avoid pressing the Emergency Stop switch unnecessarily while the Manipulator is running normally.

- The Manipulator may hit the peripheral equipment.
When you press the Emergency Stop switch, the operating trajectory until the robot system stops is different from that in normal operation.
- The life of the brakes will be shortened.
The brakes are locked and the brake friction plate is worn.
Normal brake life cycle: About 2 years (when the brakes are used 100 times/day)
However, the rough normal relay life is approximately 20,000 times. If you press the emergency stop switch unnecessarily, the life of the relay will be shortened.
- Impact is applied on the reduction gear unit, and it may result in the short life of the reduction gear unit.

To place the robot system in emergency mode during normal operation, press the Emergency Stop switch while the Manipulator is not moving.

Refer to the Robot Controller manual for instructions on how to wire the Emergency Stop switch circuit.

Do not turn OFF the Controller while the Manipulator is operating.

If you attempt to stop the Manipulator in emergency situations, make sure to stop the Manipulator using the E-STOP of the Controller.

If the Manipulator is stopped by turning OFF the Controller while it is operating, the following problems may occur.

Reduction of the life and damage of the reduction gear unit

Position gap at the joints

In addition, if the Controller was forced to be turned OFF by blackouts and the like while the Manipulator is operating, make sure to check the following points after power restoration.

Whether or not the reduction gear is damaged

Whether or not the joints are in their proper positions

If there is a position gap, perform calibration by referring to “*C series Maintenance Manual 16. Calibration*”.

Before using the Emergency Stop switch, be aware of the followings.

- The Emergency Stop (E-STOP) switch should be used to stop the Manipulator only in case of emergencies.
- To stop the Manipulator operating the program except in emergency, use Pause (halt) or STOP (program stop) commands.
Pause and STOP commands do not turn OFF the motors. Therefore, the brake does not function.
- For the safeguard, do not use the E-STOP circuit.

To check brake problems, refer to “*Regular Inspection 1. Regular Inspection for C4 Manipulator*”.

NOTE



Test pulse cannot be used with the emergency stop input of this model.

Stopping distance in emergency

The Manipulator in operation cannot stop immediately after the Emergency Stop switch is pressed. In addition, stopping time and stopping distance vary by following factors:

Hand weight	WEIGHT Setting	ACCEL Setting
Workpiece weight	SPEED Setting	Posture etc.

For stopping time and stopping distance of the Manipulator, refer to “*Appendix B: Stopping Time and Stopping Distance in Emergency*”.

1.5 Safeguard

To ensure safe operation, install a safety system using safety doors, light curtains, safety floor mats, etc. The “Safeguard” described in this manual is one of the safety system.

When a closed safeguard is open during robot motion, the safeguard interlock function operates. The robot stops immediately and enters into pause state. Then, all robot motors are turned OFF. The descriptions below explain how the safeguard input works.

Safeguard open : The robot stops immediately, motors are turned OFF, and further operation is impossible until either the safeguard is closed or TEACH or TEST mode is turned ON and the enable circuit is engaged.

Safeguard closed : The robot can automatically operate in unrestricted (high power) state.

Do not open the safeguard unnecessarily while motor is ON. Frequent safeguard inputs affect the life of the relay.

Rough normal relay life: Approximately 20,000 times

For the safeguard, do not use the E-STOP circuit.

For details of wiring instructions, refer to the following manuals.

RC90 series Manual 9. *EMERGENCY*

RC700 series Manual 11. *EMERGENCY*

For details of the safeguard, refer to the following manuals as well.

RC90 series Manual 2.7.1 *Connection to EMERGENCY Connector*

RC700 series Manual 2.7.1 *Connection to EMERGENCY Connector*



Test pulse cannot be used with the safeguard input of this model.

 WARNING	<ul style="list-style-type: none"> ■ The EMERGENCY connector on the controller has a safeguard input circuit to connect the safety device interlock switch. To protect operators working near the robot, be sure to connect the interlock switch and make sure that it works properly. ■ The time to stop the robot and the stopping distance by the safeguard interlock function will change depending on the conditions of use. Be sure to confirm that safety is ensured according to the installation environment of the robot.
--	---

Stopping distance when the safeguard is opened

The Manipulator in operation cannot stop immediately after the safeguard is opened. In addition, stopping time and stopping distance vary by following factors:

Hand weight	WEIGHT Setting	ACCEL Setting
Workpiece weight	SPEED Setting	Posture etc.

For stopping time and stopping distance of the Manipulator, refer to “*Appendix C: Stopping Time and Stopping Distance When the Safeguard is Opened*”.

1.6 How to Move Arms with the Electromagnetic Brake

There are two methods to release the electromagnetic brake. Follow either method to release the electromagnetic brake and move the arms manually.

1.6.1 Moving the arm using the brake release unit

Follow the method when you just unpack the delivered boxes or when the Controller does not start up yet.

1.6.2 Moving the arm using the software

Follow the method when you can use the software.

While the electromagnetic brake is ON (such as in emergency mode), you cannot move any arm by pushing manually.

Arm Motion

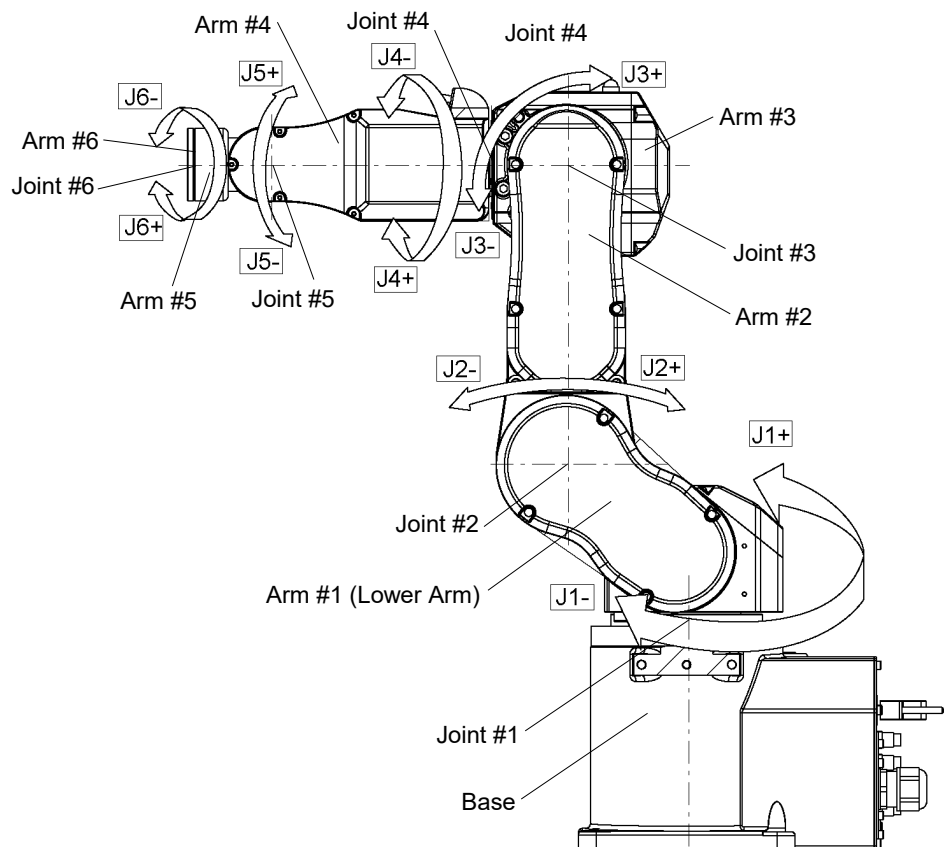

1.6.1 Moving the Arm using the brake release unit

The C4 series has the Brake Release Unit as an option.
 For details, refer to “6 Options”.

1.6.2 Moving the Arm using the software

 CAUTION	<ul style="list-style-type: none"> ■ Normally, release the brake of joints one by one. Take extra care if you need to release the brakes of two or more joints simultaneously. Releasing the brakes of two or more joints simultaneously may cause hands and fingers to be caught and/or equipment damage to or malfunction of the Manipulator as the arms of the Manipulator may move in unexpected directions. ■ After releasing the brake, the arm may fall by its own weight or move to the unexpected direction. Make sure to prepare a countermeasure to prevent the arm from falling and check the operation environment is safe. ■ Before releasing the brake, be sure to keep the Emergency Stop switch handy so that you can immediately press the Emergency Stop switch. Otherwise, you cannot immediately stop the arm falling due to an erroneous operation. The arm falling may cause equipment damage to and/or malfunction of the Manipulator.
--	---

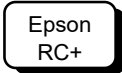

After releasing the Emergency Stop switch, execute the following command in [Command Window].

```
>Reset
>Brake Off, [the number (from 1 to 6) corresponding to the arm whose brake will be turned OFF]
```

Execute the following command to turn on the brake again.

```
>Brake On, [The number (from 1 to 6) corresponding to the arm whose brake will be turned ON]
```

1.7 Precaution for Operation in Low Power Status

In the low power status, the Manipulator operates at low speed and low torque. However, comparatively high torque as shown in the table below may be generated to support the Manipulator’s own weight.

Carefully operate the Manipulator since it may get your hands or fingers caught during operation. The Manipulator may also collide with peripheral equipment and cause equipment damage to or malfunction of the Manipulator.

Maximum Joint Torque in Low Power Status [Unit: N·m]

Joint	#1	#2	#3	#4	#5	#6
Joint Torque	116.24	193.74	59.31	12.45	11.41	6.88

 CAUTION	<ul style="list-style-type: none"> ■ Carefully operate the Manipulator in the low power status. A comparatively high joint torque may be generated. It may cause your hands and fingers caught and/or cause equipment damage to or malfunction of the Manipulator as it may collide with peripheral equipment.
--	---





1.8 Warning Labels



The Manipulator has the following warning labels.

The warning labels are attached around the locations where specific dangers exist.

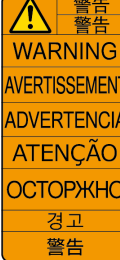
Be sure to comply with descriptions and warnings on the labels to operate and maintain the Manipulator safely.

Do not tear, damage, or remove the warning labels. Use meticulous care when handling those parts or units to which the following warning labels are attached as well as the nearby areas.

Location	Warning Label	NOTE
A	  <p>警告 警告 警告 警告 경고 OSTOPЖHO</p> <p>WARNING AVERTISSEMENT ADVERTENCIA ATENÇÃO OSTOPЖHO</p> <p>当心落下 当心落下 転倒の危険 전도 위험 ОПАСНОСТЬ ОПРОКИДЫВАНИЯ</p> <p>TIP-OVER HAZARD RISQUE DE BASCULEMENT PELIGRO DE VUELCO PERIGO DE QUEDA ОПАСНОСТЬ ОПРОКИДЫВАНИЯ</p> <p>在卸下底座安裝螺栓之前，請採取措施防止機械手掉落。 在卸下底座安裝螺栓之前，請採取措施防止機械手掉落。 Take measures to prevent the manipulator from falling and dropping before removing base mounting bolts. Prendre les mesures nécessaires pour empêcher le manipulateur de tomber avant de démonter les vis de fixation de base. Tomar medidas para evitar que el manipulator se caiga antes de retirar los pernos de montaje de la base. Tomar medidas para evitar que o manipulator caia antes de remover os parafusos de montagem da base. Перед снятием болтов крепления основания примите меры для предотвращения падения и падения манипулятора. 베이스 볼트를 제거하기 전에 손잡이 낙하하지 않도록 조치를 취하십시오. マニピュレータの落下防止対策を行ってください。</p>	<p>To avoid getting hands or fingers caught, fold the Arm and fix it with a belt or a similar tool before removing the base mounting screws.</p>
B	  <p>警告 警告 警告 警告 경고 OSTOPЖHO</p> <p>WARNING AVERTISSEMENT ADVERTENCIA ATENÇÃO OSTOPЖHO</p> <p>当心碰撞 当心碰撞 衝突の危険 충돌 위험 ОПАСНОСТЬ СТОЛКНОВЕНИЯ</p> <p>COLLISION HAZARD RISQUE DE COLLISION PELIGRO DE COLISION PERIGO DE COLISÃO ОПАСНОСТЬ СТОЛКНОВЕНИЯ</p> <p>稼働時、機械臂可能全导致死亡或重伤。 稼働時、機械臂可能全导致死亡或重伤。 When moving, robot arm can cause death, or serious injury. Do not enter work envelope. En se déplaçant, le bras du robot peut provoquer des blessures graves ou mortelles. Ne pas pénétrer dans l'enveloppe de travail. Cuando se mueve, el brazo del robot puede causar la muerte o lesiones graves. No entre en el sobre de trabajo. Ao se mover, o braço do robô pode causar morte ou ferimentos graves. Não entre na área de trabalho. При движении рука робота может стать причиной смерти или серьезной травмы. Не входите в рабочий конверт. 로봇 암이 움직이면 사망 또는 중상의 가능성이 있습니다. 작업 영역에 들어가지 마십시오. マニピュレーター稼働中は、絶対に動作エリアに入らないでください。アームに衝突する可能性があります。</p>	<p>Do not enter the work space when the Manipulator is operating. It is extremely hazardous since the Arm may collide and cause serious safety problems,</p>
C	  <p>警告 警告 警告 警告 경고 OSTOPЖHO</p> <p>WARNING AVERTISSEMENT ADVERTENCIA ATENÇÃO OSTOPЖHO</p> <p>当心触电 当心触电 带电の危険 전도 위험 ОПАСНОСТЬ ПОРАЖЕНИЯ ЭЛЕКТРИЧЕСКИМ ТОКОМ</p> <p>ELECTRIC SHOCK HAZARD RISQUE DE CHOC ELECTRIQUE PELIGRO DE DESCARGA ELECTRICA PERIGO DE CHOQUE ELÉTRICO ОПАСНОСТЬ ПОРАЖЕНИЯ ЭЛЕКТРИЧЕСКИМ ТОКОМ</p> <p>当心高温表面 当心高温表面 熱い表面 고온 표면 ГОРЯЧАЯ ПОВЕРХНОСТЬ</p> <p>HOT SURFACE SURFACE CHAUDE SUPERFICIE CALIENTE SUPERFICIE QUENTE ГОРЯЧАЯ ПОВЕРХНОСТЬ</p>	<p>Do not touch the current-carrying parts inside the Manipulator while the power is ON. It may cause electrical shock.</p>

Location	Warning Label	NOTE
D		<p>Be careful of the arm falling due to its own weight when pressing the brake release switch.</p> <p>These labels are attached on the optional brake release unit as well.</p> <hr/> <p>When the brake release unit is used: Details of procedures for releasing the brakes using the brake release unit are described in the Manipulator manuals.</p>
E		<p>Only authorized personnel should perform sling work and operate a crane and a forklift. When these operations are performed by unauthorized personnel, it is extremely hazardous and may result in serious bodily injury and/or severe equipment damage to the robot system.</p>

Location	Label	NOTE
1	-	<p>The product name, model name, serial number, information which laws and regulations are supported, product specifications, manufacturer, importer, date of manufacture, country of manufacture, etc. are listed.</p> <p>For details, see the label affixed to the product.</p>

Location of Labels

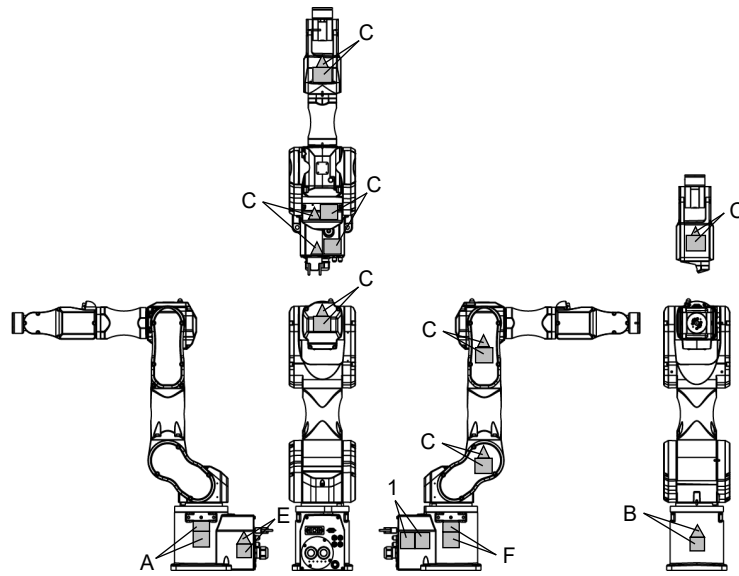

1.9 Response for Emergency or Malfunction

1.9.1 Collision

When the Manipulator collides with a mechanical stopper or peripheral device etc., discontinue use and contact the supplier.

1.9.2 Getting body caught in Manipulator

When the operator is caught between the Manipulator and a mechanical part such as a base table, press the emergency stop switch to release the brake on the subject arm, and then move the arm by hand.

How to release a brake

When using a brake release unit

For details, refer to “*6.1 Brake Release Unit*”.

When using software

For details, refer to “*1.6.2 Moving the Arm using the software*”.

2. Specifications

2.1 Model Number

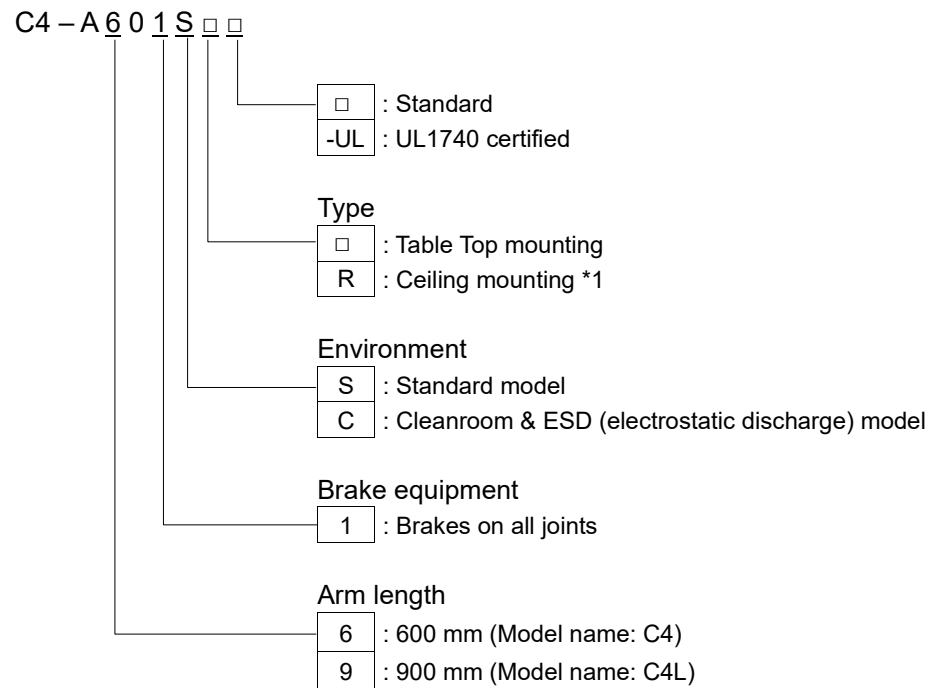

*1 Manipulators are set to “Table Top mounting” at shipment. To use the Manipulators as “Ceiling mounting”, you need to change the model settings. For details on how to change the model settings, refer to “5.5 Changing the Robot”, and “Epson RC+ User’s Guide Robot Configuration”.

2.2 Part Names and Motion Range of Each Arm

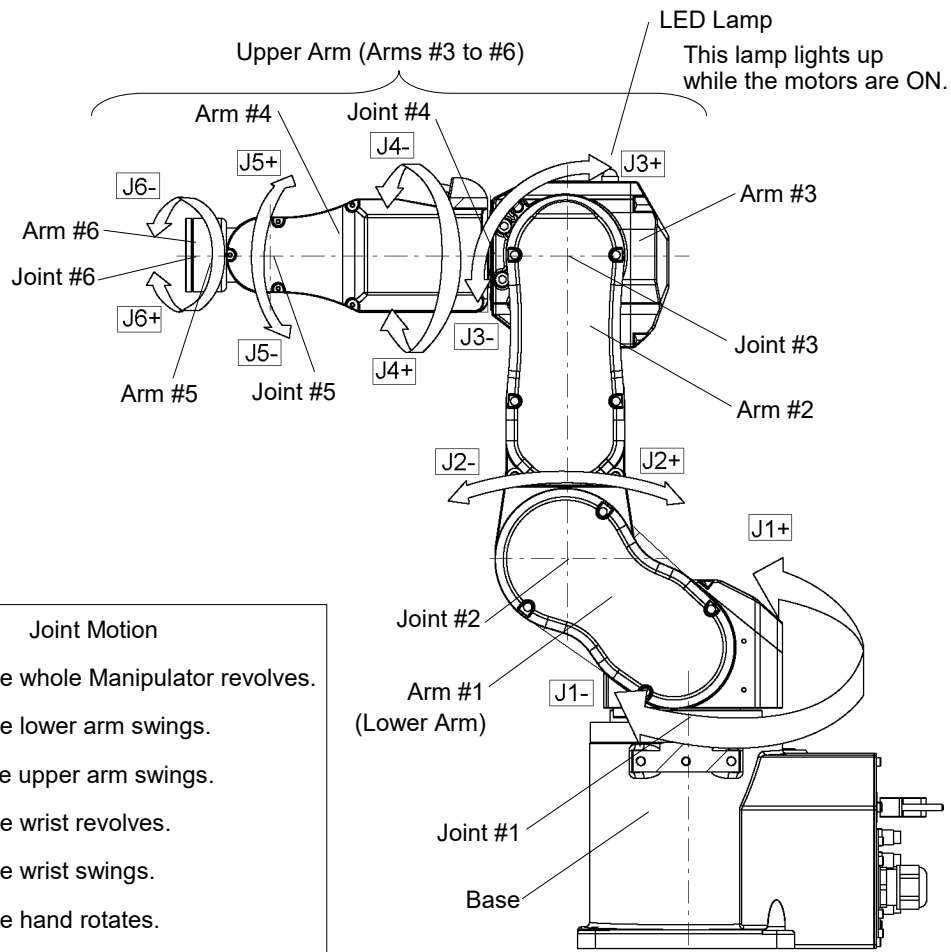

Joint Motion

Joint #1 : The whole Manipulator revolves.
 Joint #2 : The lower arm swings.
 Joint #3 : The upper arm swings.
 Joint #4 : The wrist revolves.
 Joint #5 : The wrist swings.
 Joint #6 : The hand rotates.

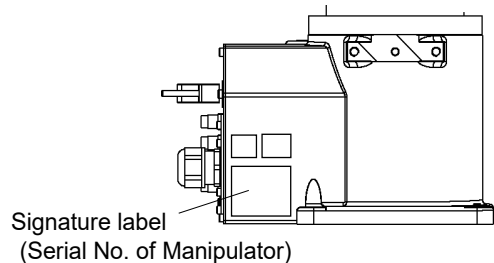
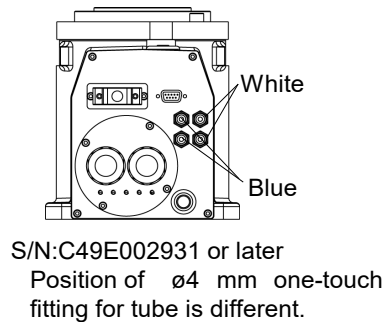
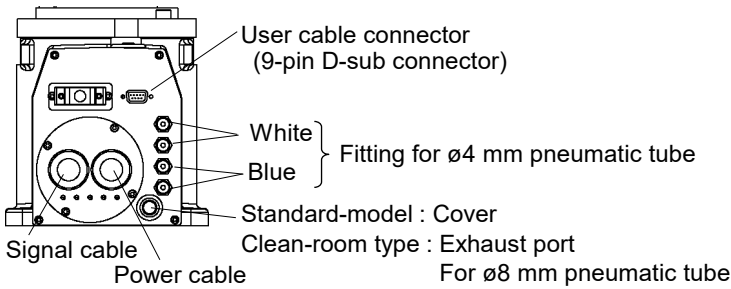

NOTE When the LED lamp is lighting or the Controller power is on, the current is being applied to the Manipulator. (The LED lamp may not be seen depending on the Manipulator's posture. Be very careful.) Performing any work with the power ON is extremely hazardous and it may result in electric shock and/or improper function of the robot system. Make sure to turn OFF the Controller power before the maintenance work.

2.3 Outer Dimensions

2.3.1 C4-A601**

[Unit: mm]

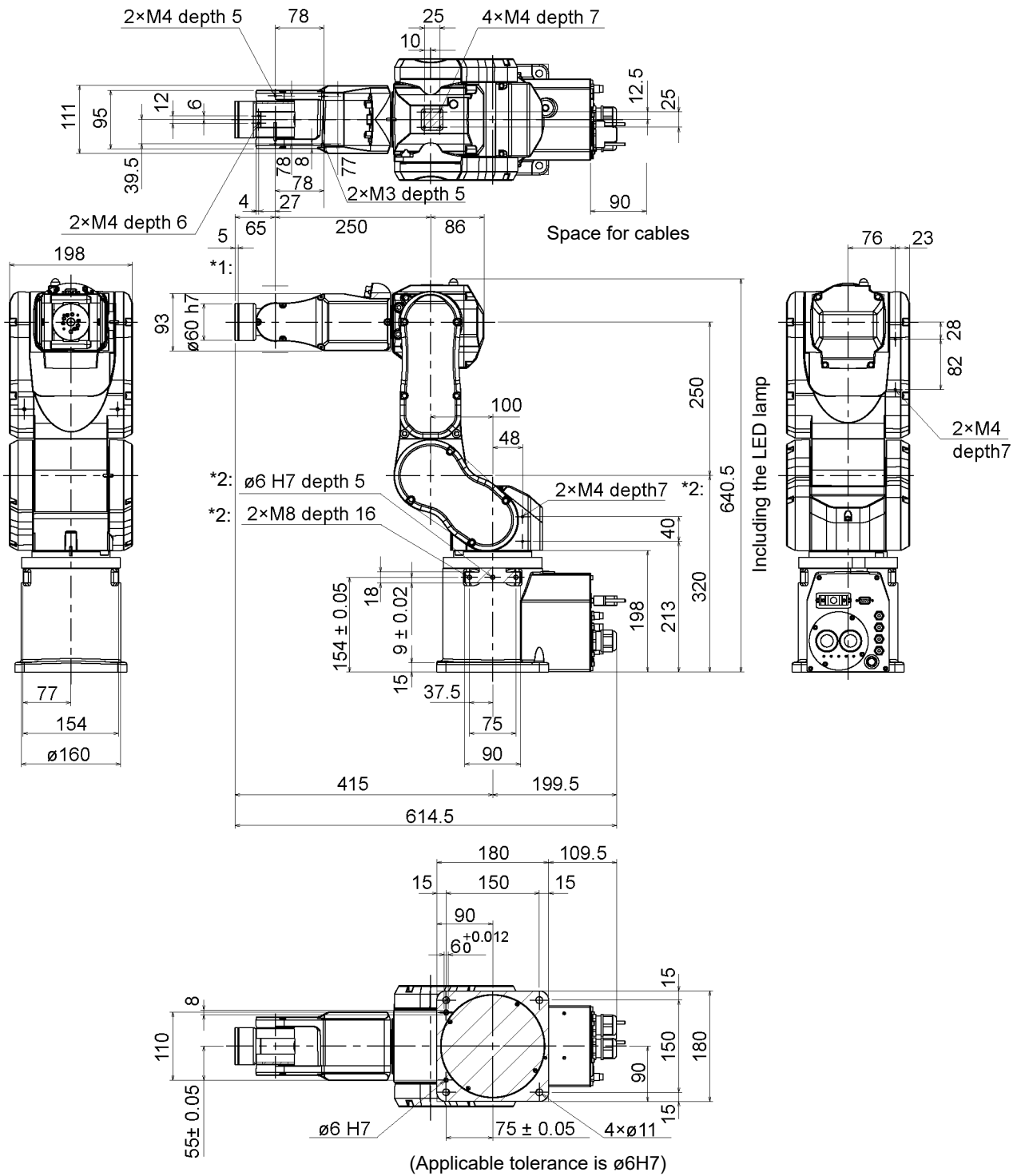

*1: Applicable area: $\phi 60$ h7

*2: Same for the other side

2.3.2 C4-A901**

[Unit: mm]

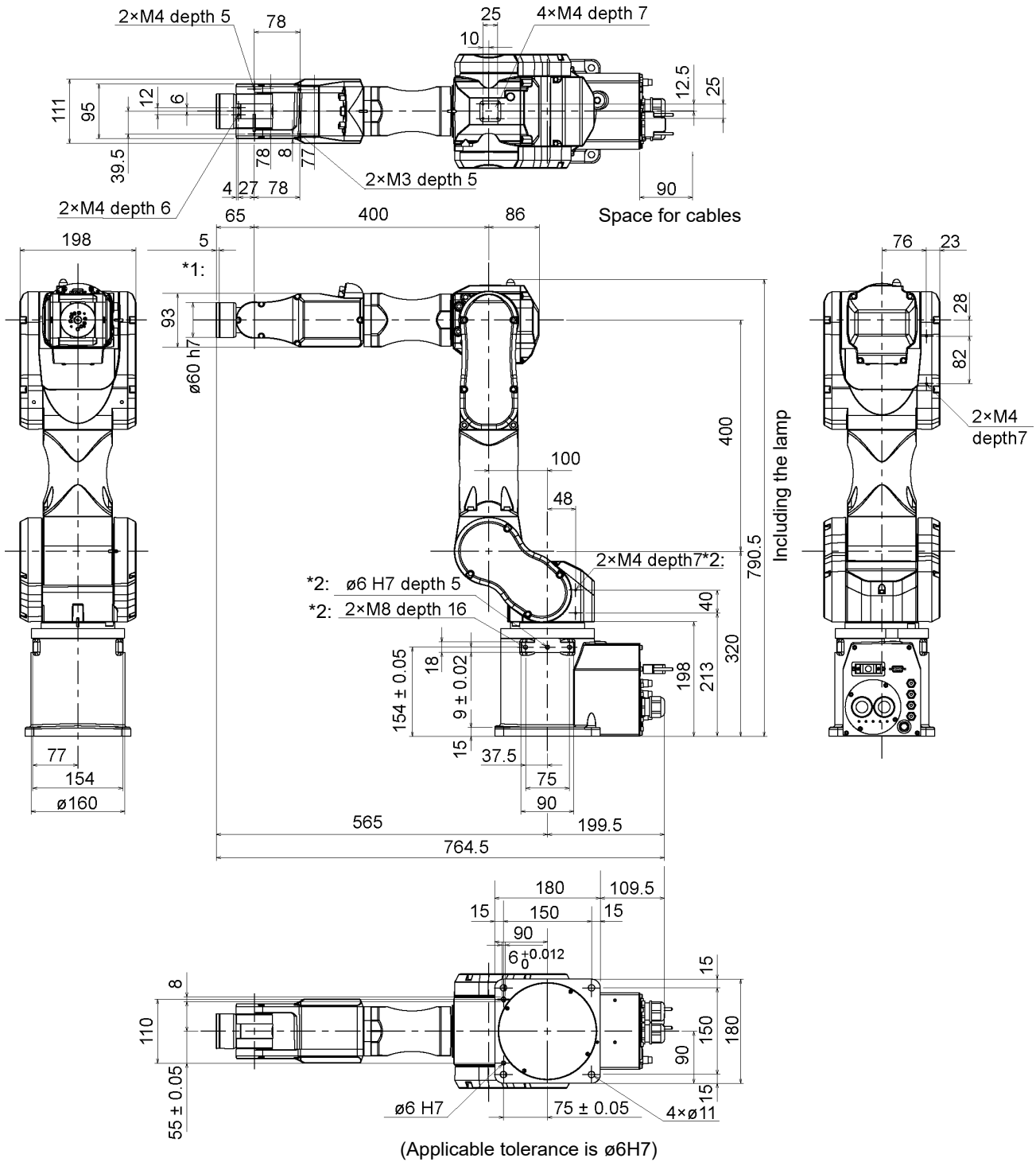

2.4 Standard Motion Range

2.4.1 C4-A601**

[Unit: mm]

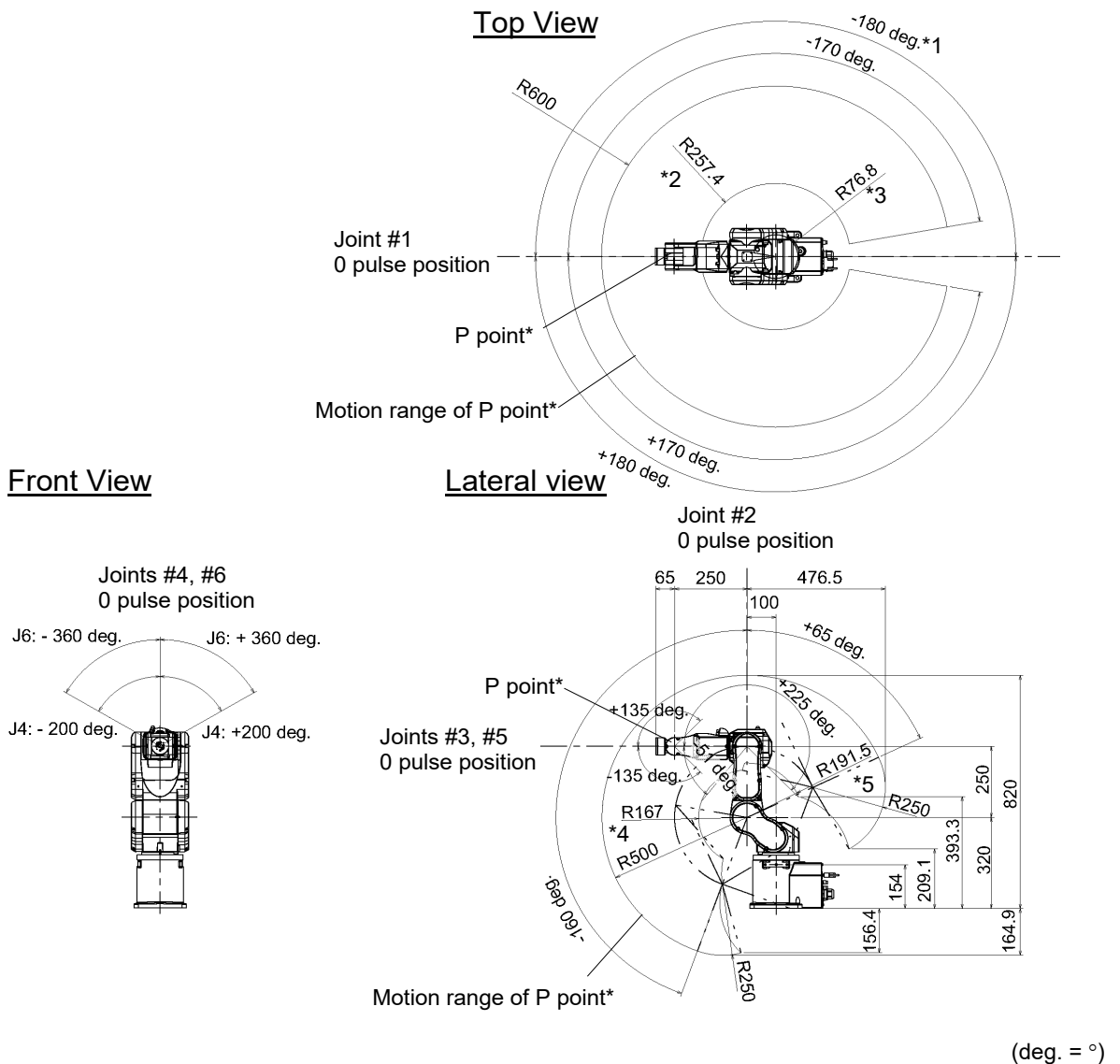

(deg. = °)

- * P point : Intersection of the rotation centers for Joint #4, #5, and #6
- *1 : Joint #1 without mechanical stop ($\pm 180^\circ$)
 For the mechanical stop removal procedure, refer to "5.2.1 Motion Range Setting of Arm #1".
- *2 : P point from top with Joint #3 declining -51° (Joint #1 center – P point center)
- *3 : P point from top with Joint #3 tilting up $+225^\circ$ (Joint #1 center – P point center)
- *4 : P point from lateral with Joint #3 declining -51° (Joint #2 center – P point center)
- *5 : P point from lateral with Joint #3 tilting up $+225^\circ$ (Joint #2 center – P point center)

 CAUTION	<p>■ Pay attention to the arm pose of the basic arms (Arms #1, #2, and #3) when operating the Manipulator. Arm #5 moves keeping a constant angle regardless of the arm pose. Depending on the arm pose of the basic arms, the wrist may collide with the Manipulator. The collision may cause equipment damage to and/or malfunction of the Manipulator.</p>
--------------------	--

2.4.2 C4-A901**

[Unit: mm]

Top View

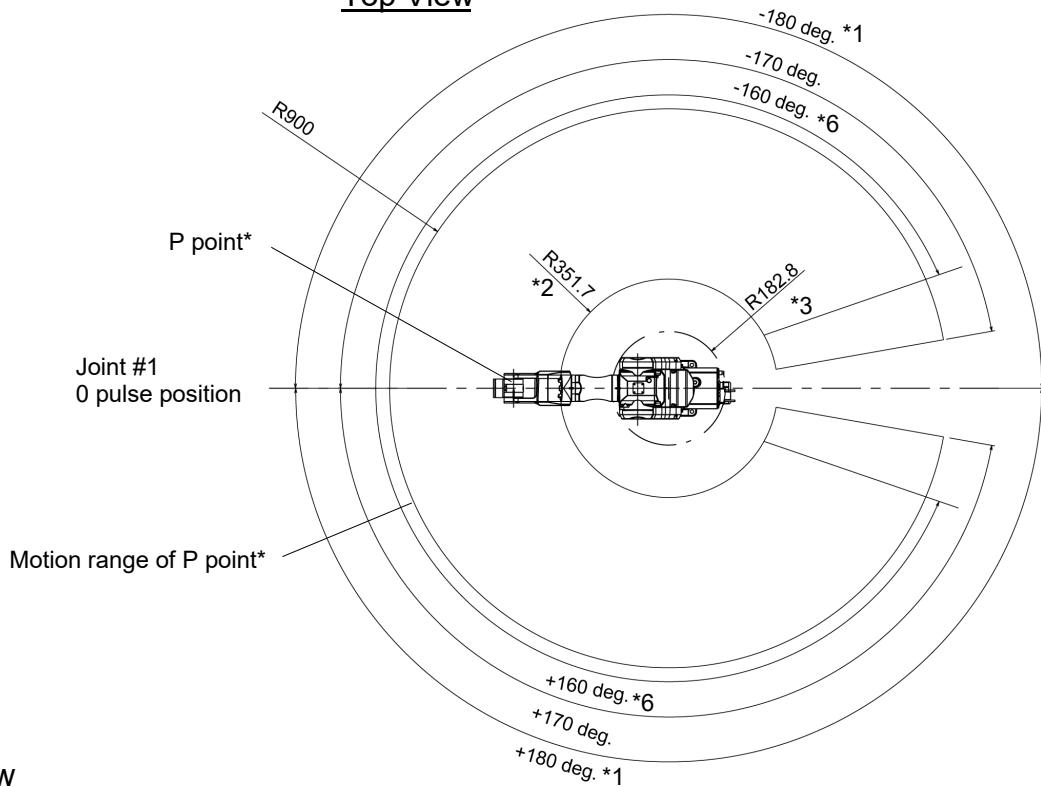

Front View

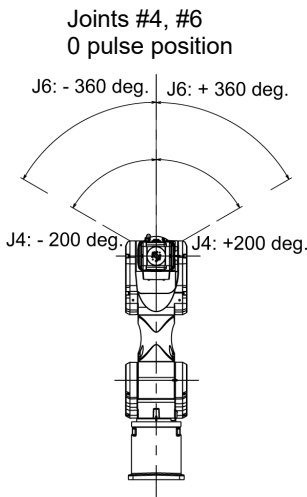

Lateral view

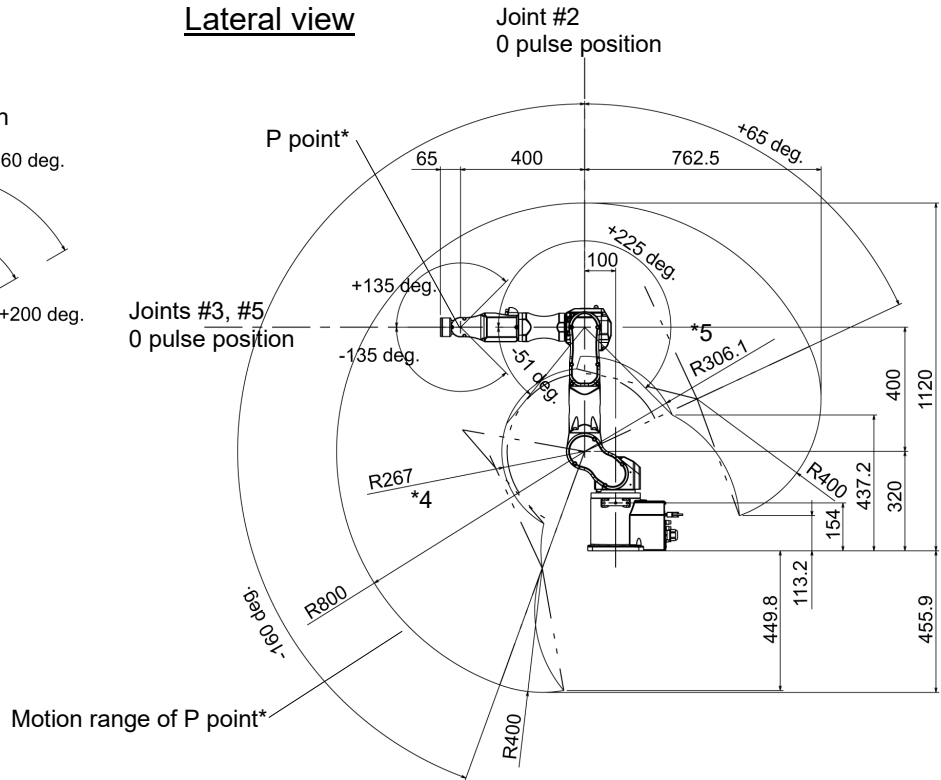

(deg. = °)

- * P point : Intersection of the rotation centers for Joint #4, #5, and #6
- *1 : Joint #1 without mechanical stop ($\pm 180^\circ$)
For the mechanical stop removal procedure, refer to "5.2.1 Motion Range Setting of Arm #1".
- *2 : P point from top with Joint #3 declining -50° (Joint #1 center – P point center)
- *3 : P point from top with Joint #3 tilting up $+210^\circ$ (Joint #1 center – P point center)
- *4 : P point from lateral with Joint #3 declining -50° (Joint #2 center – P point center)
- *5 : P point from lateral with Joint #3 tilting up $+210^\circ$ (Joint #2 center – P point center)
- *6 : Max. motion range of Joint #1 for UL specification of C4L is $\pm 160^\circ$.



CAUTION

- Pay attention to the arm pose of the basic arms (Arms #1, #2, and #3) when operating the Manipulator. Arm #5 moves keeping a constant angle regardless of the arm pose. Depending on the arm pose of the basic arms, the wrist may collide with the Manipulator. The collision may cause equipment damage to and/or malfunction of the Manipulator.

2.5 Specifications

2.5.1 Specifications Table

For the specifications of each model, refer to “*Appendix A: Specifications table*”.

2.5.2 Option

C4 series have the following options.

- Brake release unit
- Camera mounting plate
- PS compatible plate (Tool adapter, Base adapter)
- Base side angled fittings
- Base side fittings
- Adjustable Mechanical Stop (Joint #2: Only C4-A901**)

For details of options, refer to “*6. Options*”.

2.6 How to Set the Model

The Manipulator for your system has been set before shipment from the factory.



CAUTION

- When you need to change the setting of the Manipulator model, be sure to set the Manipulator model properly. Improper setting of the Manipulator model may result in abnormal or no operation of the Manipulator and/or cause safety problems.

NOTE



If the custom specifications number (MT****) or (X****) is described on the signature label (S/N label), the Manipulator has custom specifications. (A label with only the custom specifications number may be attached depending on shipment time.)

The custom specifications may require a different configuration procedure; check the custom specifications number and contact the supplier of your region when necessary.

The Manipulator model can be set from software.

Refer to the chapter *Robot Configuration* in the *Epson RC+ User's Guide*.

3. Environment and Installation

Unpacking and transportation of the Manipulators and robotic equipment shall be performed by personnel who has taken robot system training held by us and suppliers and should conform to all national and local codes.

3.1 Environmental Conditions

A suitable environment is essential for the robot system to function properly and safely. Be sure to install the robot system in an environment that meets the following conditions:

Item	Conditions
Ambient temperature*	5 to 40 °C
Ambient relative humidity	20 % to 80 % (no condensation)
Fast transient burst noise	1 kV or less (Signal wire)
Electrostatic noise	4 kV or less
Altitude	1000 m or lower
Environment	<ul style="list-style-type: none"> - Install indoors - Keep away from direct sunlight - Keep away from dust, oily smoke, salinity, metal powder or other contaminants - Keep away from flammable or corrosive solvents and gases - Keep away from water - Keep away from shock or vibration - Keep away from sources of electric noise - Keep away from explosive area - Keep away from a large quantity of radiation

* The ambient temperature conditions are for the Manipulators only. For the Controller the Manipulators are connected to, refer to the Robot Controller manual.

When the product is used in a low temperature environment around the minimum temperature of the product specification, or when the product is suspended for a long time on holidays or at night, a collision detection error may occur due to the large resistance of the drive unit immediately after the start of operation. In such a case, it is recommended to warm up for about 10 minutes.



When using the Manipulators in inadequate environments that do not meet the above conditions, please contact the supplier of your region.

Special Environmental Conditions

The surface of the Manipulator has general oil resistance. However, if your requirements specify that the Manipulator must withstand certain kinds of oil, please contact the supplier of your region.

Rapid change in temperature and humidity can cause condensation inside the Manipulator.

If your requirements specify that the Manipulator handles food, please contact the supplier of your region to check whether the Manipulator will damage the food or not.

The Manipulator cannot be used in corrosive environments where acid or alkaline is used. In a salty environment where the rust is likely to gather, the Manipulator is susceptible to rust.

 <p>WARNING</p>	<ul style="list-style-type: none">■ Use an earth leakage breaker on the AC power cable of the Controller to avoid the electric shock and circuit breakdown caused by an unexpected water leak. Prepare the earth leakage breaker that pertains the Controller you are using. For details, refer to the Robot Controller manual.
--	---



 <p>CAUTION</p>	<ul style="list-style-type: none">■ When cleaning the Manipulator, do not rub it strongly with alcohol or benzene. It may lose luster on the coated face.
--	---

3.2 Unpacking, Transportation, and Relocation

Using a cart or similar equipment, transport the Manipulator in the same conditions as it was delivered. Observe the following when unpacking the Manipulator.

Unpacking, transportation, and relocation shall be performed by personnel who has taken robot system training held by us and suppliers and should conform to all national and local codes.

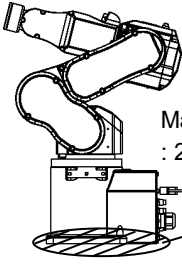
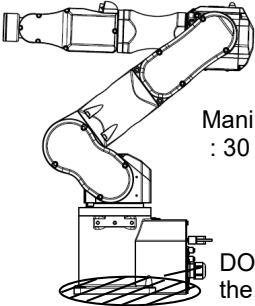
 WARNING	<ul style="list-style-type: none"> Only authorized personnel should perform sling work and operate a crane or a forklift. When these operations are performed by unauthorized personnel, it is extremely hazardous and may result in serious bodily injury and/or severe equipment damage to the robot system. Stabilize the Manipulator with your hands when hoisting it. Unstable hoisting is extremely hazardous and may result in serious bodily injury and/or severe equipment damage to the robot system as the fall of the Manipulator.
---	--

 CAUTION	<ul style="list-style-type: none"> When removing the anchor bolts, support the Manipulator to prevent falling. Removing the anchor bolts without supporting the Manipulator may get hands, fingers, or feet caught as the Manipulator may fall. To transport the Manipulator, secure it to the delivery equipment or have at least 2 people to hold it by hand. Also, do not hold the bottom of the base (the screened parts in the figure). Holding these parts by hand is extremely hazardous and may cause your hands and fingers caught. <div style="display: flex; justify-content: space-around;"> <div style="text-align: center;"> <p>C4-A601**</p>  <p>Manipulator weight : 27 kg (59.5 lbs.)</p> <p>DO NOT hold the bottom of the base by hand.</p> </div> <div style="text-align: center;"> <p>C4-A901**</p>  <p>Manipulator weight : 30 kg (66.1 lbs.)</p> <p>DO NOT hold the bottom of the base by hand.</p> </div> </div> <ul style="list-style-type: none"> Avoid excessive vibration or shock during Manipulator transporting. Excessive vibration or shock may cause equipment damage to and/or malfunction of the Manipulator. Take extra care when transporting the Manipulator. You may hit and damage the connector <div style="text-align: center; margin-top: 10px;">  </div>
---	--

During unpacking and relocation, avoid applying external force to the arms and motors of the Manipulator.

When transporting the Manipulator for a long distance, secure it to the delivery equipment so that the Manipulator cannot fall. If necessary, pack the Manipulator in the same way as it was delivered.

When condensation occurs on the Manipulator during transport or storage, turn ON the power only after the condensation dries.

Be sure to transport and store the robot system in environments that meet the following conditions:

Item	Conditions
Ambient temperature	-20 to 60 °C
Ambient relative humidity	10 to 90 % (no condensation)

When using the Manipulator for the robot system again after long-term storage, perform a test run to verify that the Manipulator works properly. Then, operate the Manipulator thoroughly.

Relocating

Follow the procedures described below when relocating the Manipulator.

- (1) Turn OFF the power for all devices and unplug the power cable connector and signal cable connector from the Controller.

Do not unplug the M/C cable (power cable and signal cable) from the Manipulator.
(MC cable 3 m: 2 kg)



Remove the mechanical stops if using them to limit the motion range.
For details on the motion range, refer to the “5.2 Motion Range Setting by Mechanical Stops”.

- (2) Unscrew the anchor bolts. Then, remove the Manipulator from the base table.

- (3) C4-A601**

Position the Manipulator as shown in the figure. Then, secure the Manipulator to the delivery equipment or have at least 2 people to carry the Manipulator.

Recommend: Joint #2 +65°.
Joint #3 -51°.

Do not hold the bottom of the base (the screened parts in the figure). Holding these parts by hand is extremely hazardous and may cause your hands and fingers to be caught.

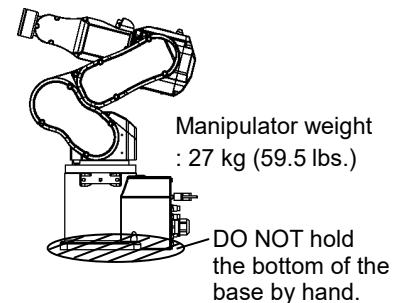

- C4-A901**

Position the Manipulator as shown in the figure. Then, secure the Manipulator to the delivery equipment or have at least 3 people to carry the Manipulator.

Recommend: Joint #2 +53°.
Joint #3 -51°.

Do not hold the bottom of the base (the screened parts in the figure). Holding these parts by hand is extremely hazardous and may cause your hands and fingers to be caught.

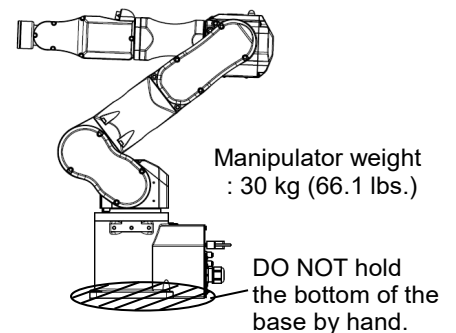

Using Eyebolt

Check that the eyebolts are securely fastened before carrying the Manipulator.
 After transporting the Manipulator, remove the eyebolts and keep them for future use.

The eyebolts and wire must be strong enough to withstand the weight (See the figures below).
 If you use the eyebolts to lift up the Manipulator, be sure to use the bifilar wire of 1 m long or more to avoid contact with the Arm #4 side cover.

Also, the Manipulator may swing while being lifted up even when using the appropriate length of wire, so be sure to handle it with care.

Take extra care if you use the wire of 240 mm-long or shorter (for C4-A601**), or 360 mm-long or shorter (for C4-A901**), to lift the Manipulator, because the wire is likely to touch the Arm #4 side cover and break the Manipulator.

(deg.= °)

C4-A601**

Lifting load:
 27 kg (59.5 lbs.)

Holes for eye bolt
 2-M6 depth 12.5

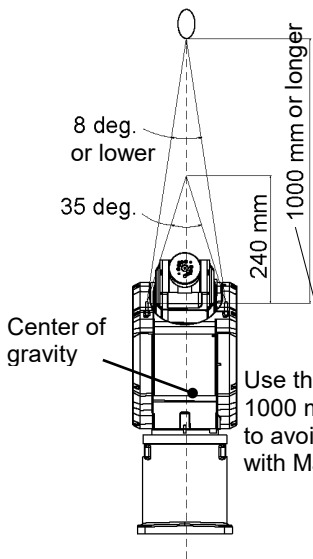
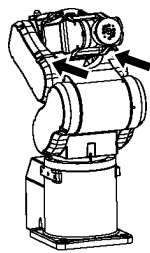

Use the wire of 1000 mm or longer to avoid contact with Manipulator.

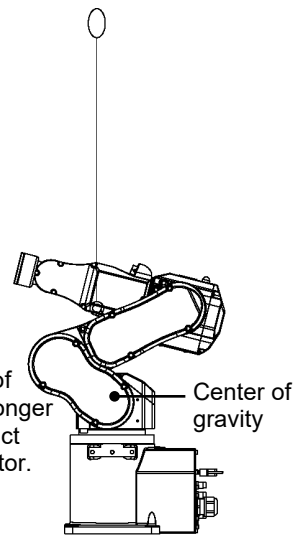

C4-A901**

Lifting load:
 30 kg (66.1 lbs.)

Holes for eye bolt
 2-M6 depth 12.5

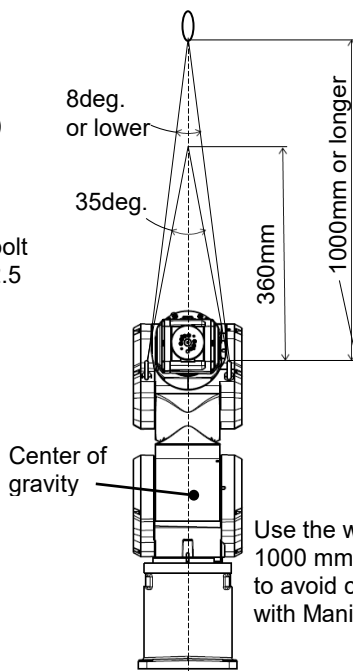

Use the wire of 1000 mm or longer to avoid contact with Manipulator.

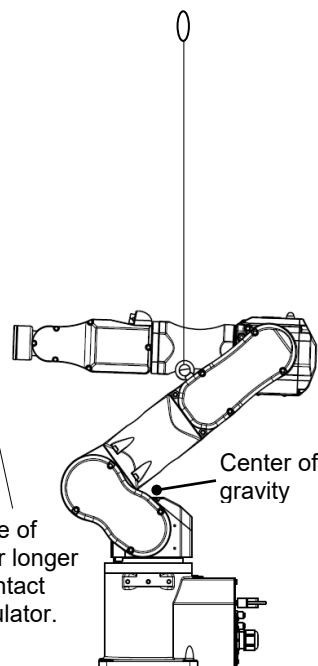

3.3 Mounting Dimensions

Mounting Area

Be sure to have the following space available in addition to the space for mounting the Manipulator, Controller, and peripheral equipment.

- Space for teaching points
- Space for maintenance and inspections (for installing jigs)
- Space for cables
- Space for mounting holes (only for V/P model)



When installing the cable, be sure to maintain sufficient distance from obstacles.
 For the minimum bend radius of the MC cable, refer to "Appendix A: C4 Specifications."
 In addition, leave enough space for other cables so that they are not bent forcibly.

Mounting Dimensions (C4 series)

[Unit: mm]

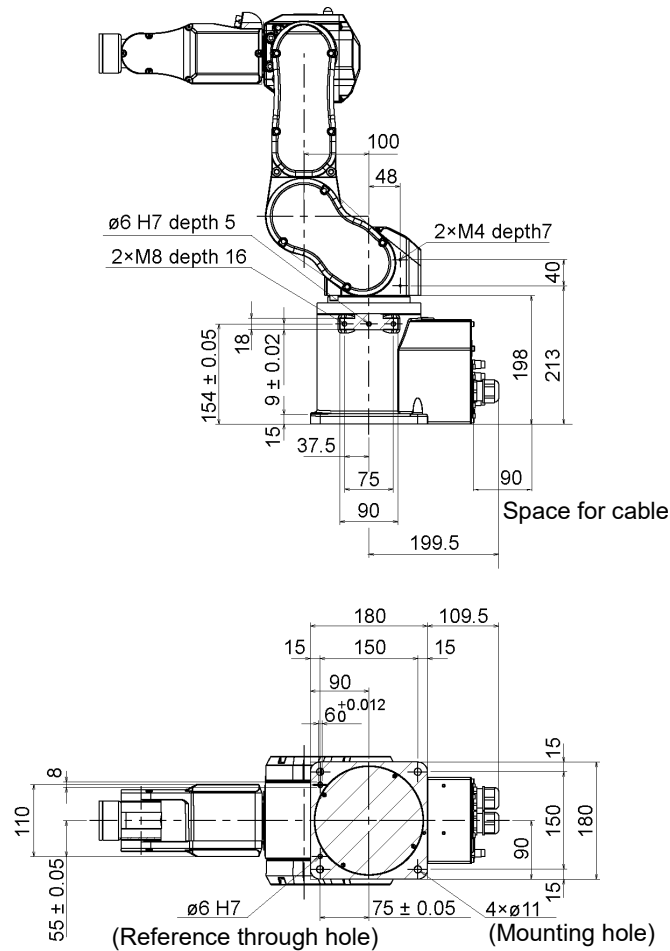

3.4 Installation

The installation shall be made by personnel who has taken robot system training held by us and suppliers and should conform to all national and local codes.

 WARNING	<ul style="list-style-type: none"> ■ To ensure safety, a safeguard must be installed for the robot system. For details on the safeguard, refer to the <i>Installation and Design Precautions</i> in the <i>Safety</i> chapter of the Epson RC+ User's Guide. ■ Install the Manipulator in a location with sufficient space so that a tool or a work piece does not touch a wall or a safeguard when the Manipulator extends its arm fully while holding a work piece. Installing the Manipulator at a location with insufficient space is extremely hazardous and may result in serious bodily injury and/or severe equipment damage to the robot system as a tool or a work piece may collide with a wall or a safeguard. ■ Anchor the Manipulator before turning ON the power to or operating the Manipulator. Turning ON the power to or operating the Manipulator that is not anchored is extremely hazardous and may result in serious bodily injury and/or severe equipment damage to the robot system as the Manipulator may fall down. ■ Before installing and operating the Manipulator, make sure that all parts of the Manipulator are in place and have no external defects. Missing or defective parts may cause improper operation of the Manipulator. Improper operation of the Manipulator is extremely hazardous and may result in serious bodily injury and/or severe equipment damage to the robot system.
--	---

 CAUTION	<ul style="list-style-type: none"> ■ The Manipulator must be installed to avoid interference with buildings, structures, utilities, other machines and equipment that may create a trapping hazard or pinch points. ■ Oscillation (resonance) may occur during operation depending on rigidity of the installation table. If the oscillation occurs, improve rigidity of the table or change the speed or acceleration and deceleration settings.
--	---

Mounting bolt

For the dimensions, refer to “3.3 Mounting Dimensions”.

There are four threaded holes for the Manipulator base.

Use M8 mounting bolts conforming to the strength equivalent to ISO898-1 property class 10.9 or 12.9.

Tightening torque:
 32.0±1.6 N·m (326±16 kgf·cm)

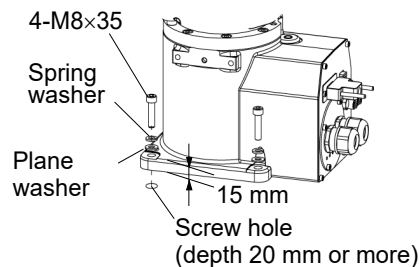

Base table

A base table for anchoring the Manipulator is not supplied. Please make or obtain the base table for your Manipulator. The shape and size of the base table differ depending on the intended use of the robot system. The following is the basic requirements of Manipulator table for your reference.

The base table must not only be able to bear the weight of the Manipulator but also be able to withstand the dynamic movement of the Manipulator when it operates at maximum acceleration/deceleration. Ensure that there is enough strength on the base table by attaching reinforcing materials such as crossbeams.

The torque and reaction force produced by the movement of the Manipulator are as follows:

	C4-A601**	C4-A901**
Max. Horizontal rotating torque	500 N·m	700 N·m
Max. Horizontal reaction force	800 N	800 N
Max. Vertical rotating torque	600 N·m	1000 N·m
Max. Vertical reaction force	2500 N	2500 N

The plate for the Manipulator mounting face should be 30 mm thick or more and made of steel to reduce vibration. The surface roughness of the steel plate should be 25 μm or less.

The base table must be secured on the floor to prevent it from moving.

The Manipulator installation surface should have a flatness of 0.5 mm or less and an inclination of 0.5 ° or less. If the flatness of the installation surface is improper, the base may be damaged or the robot may not fully show its performance.

When using a leveler to adjust the height of the base table, use a screw with M16 diameter or more.

Connector

If you are passing cables through the holes on the base table, see the figures below.

[unit : mm]

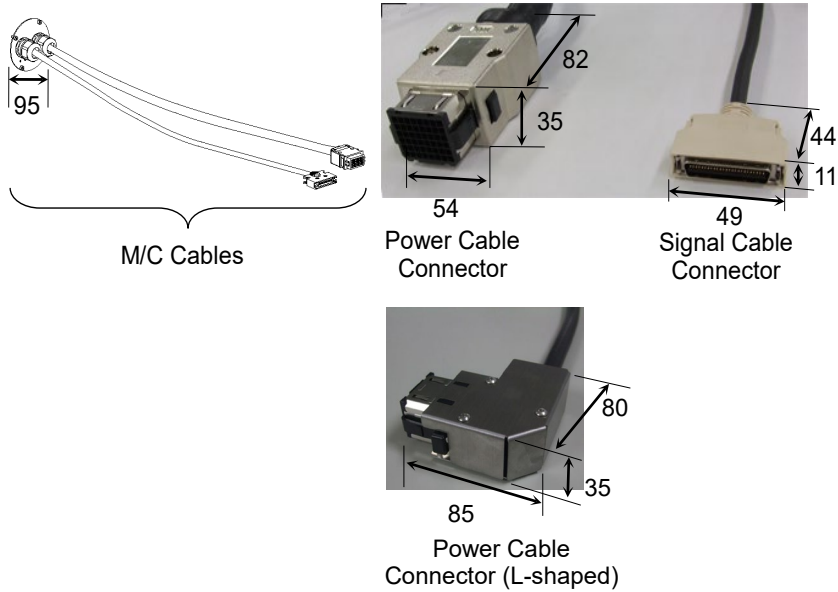

Do not remove the M/C cables from the Manipulator.





For environmental conditions regarding space when placing the Controller on the base table, refer to the Robot Controller manual.

When using the Manipulator in the clean room, follow the steps below before the installation.

- (1) Unpack it outside of the clean room.
- (2) Secure the Manipulator to delivery equipment such as a pallet with bolts so that the Manipulator does not fall.
- (3) Wipe off the dust on the Manipulator with a little alcohol or distilled water on a lint-free cloth.
- (4) Carry the Manipulator in the clean room.
- (5) Secure the Manipulator to the base table.

3.5 Connecting the Cables

 <p>WARNING</p>	<ul style="list-style-type: none"> ■ Before performing any replacement procedure, turn OFF the Controller and related equipment, and then disconnect the power plug from the power source. Performing any replacement procedure with the power ON is extremely hazardous and may result in electric shock and/or malfunction of the robot system. ■ Be sure to connect the AC power cable to a power receptacle. DO NOT connect it directly to a factory power source. To shut off power to the robot system, disconnect the power plug from the power source. Performing any work while connecting the AC power cable to a factory power source is extremely hazardous and may result in electric shock and/or malfunction of the robot system. ■ Be sure to connect the cables properly. Do not allow unnecessary strain on the cables. (Do not put heavy objects on the cables. Do not bend or pull the cables forcibly.) The unnecessary strain on the cables may result in damage to the cables, disconnection, and/or contact failure. Damaged cables, disconnection, or contact failure is extremely hazardous and may result in electric shock and/or improper function of the robot system. ■ Before wiring, turn OFF the Controller and related equipment, and then pull up a warning sign (e.g. DO NOT TURN ON THE POWER.). Wiring with the power ON is extremely hazardous and may result in electric shock and/or malfunction of the robot system. ■ Grounding the Manipulator is done by connecting with the Controller. Ensure that the Controller is grounded and the cables are correctly connected. If the ground wire is improperly connected to ground, it may result in the fire or electric shock. ■ When connecting / replacing the brake release unit or the external short connector, turn OFF the power to the Controller and the brake release unit. Inserting and removing the connector while the power is ON may result in electrical shock.
 <p>CAUTION</p>	<ul style="list-style-type: none"> ■ When connecting the Manipulator and the Controller, make sure that the serial numbers on each equipment match. Improper connection between the Manipulator and Controller may not only cause improper function of the robot system but also safety problems. The connection method varies with the Controller used. For details on the connection, refer to the Robot Controller manual. ■ Only authorized or certified personnel should be allowed to perform wiring. Wiring by unauthorized or uncertified personnel may result in bodily injury and/or malfunction of the robot system. ■ If the Manipulator is operated without connecting the brake release unit or the external short connector, the brakes cannot be released and it may cause damage on them. After using the brake release unit, be sure to connect the external short connector to the Manipulator, or check connection of the connector for the brake release unit.

Cleanroom-model Manipulator

For the Cleanroom-model, an exhaust system is necessary. For details, refer to “*Appendix A: Specifications Table*”.

M/C Cable Connection method

Connect the power connector and the signal connector of the M/C cables to the Controller.

3.6 User Wires and Pneumatic Tubes

 CAUTION	<p>■ Only authorized or certified personnel should be allowed to perform wiring. Wiring by unauthorized or uncertified personnel may result in bodily injury and/or malfunction of the robot system.</p>
---	--

User electrical wires and pneumatic tubes are contained in the cable unit.

Electrical Wires

Rated Voltage	Allowable Current	Wires	Nominal Sectional Area	Outer Diameter	Note
AC/DC30 V	1 A	9	0.211 mm ²	ø8.3 ± 0.3 mm	Shielded

		Maker	Standard
9 pin	Suitable Connector	JAE	DE-9PF-N (Solder type), DEU-9PF-F0 (Crimping type)
	Clamp Hood	JAE	DE-C8-J9-F2-1R (Connector setscrew: #4-40 NC)

Pins with the same number, indicated on the connectors on both ends of the cables, are connected.

Pneumatic Tubes

Max. Usable Pneumatic Pressure	Pneumatic Tubes	Outer Diameter × Inner Diameter
0.59 MPa (6 kgf/cm ² : 86 psi)	4	ø4 mm × ø2.5 mm

Tubes with the same number, indicated in details of View A and B, are connected.

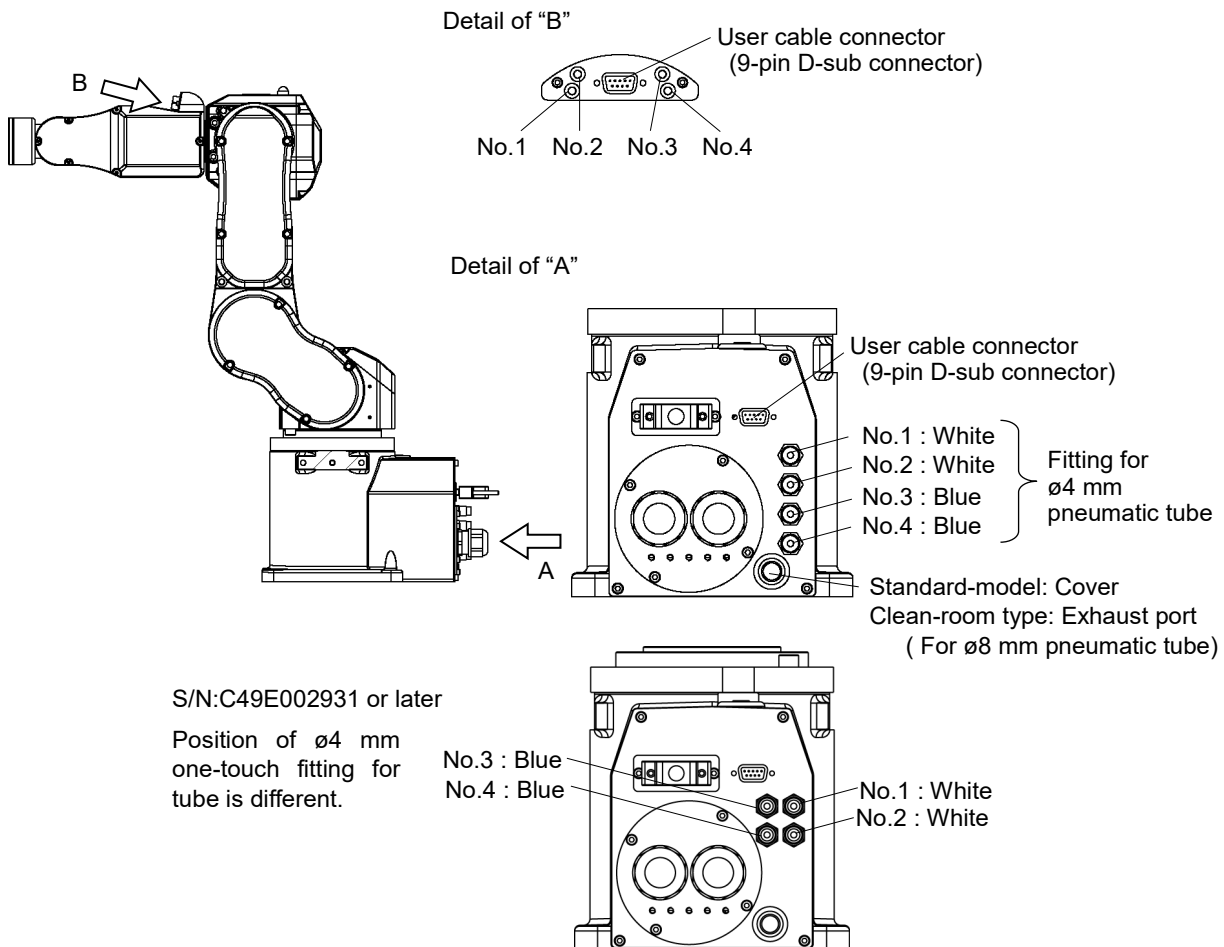

3.7 Checking the Basic orientation

After installing the Manipulator and setup the operating environment, check if it moves to the basic position properly.

Follow the steps below to set the basic orientation of the Manipulator shown below as the origin position.

- (1) Start Epson RC+.
Double click the [Epson RC+] icon on the desktop.
- (2) Open the command window.
Epson RC+ menu-[Tools]-[Command Window]
- (3) Execute the following command in [Command Window].

```
>Motor On
>Go Pulse (0,0,0,0,0,0)
```



If you move the robot which is in the posture when it was packed in a package by using the World coordinate system, an out of motion range error will occur. Follow the procedure to move to the basic posture by using the pulse command.

If the Manipulator cannot be in the basic orientation shown below, please contact the supplier of your region.

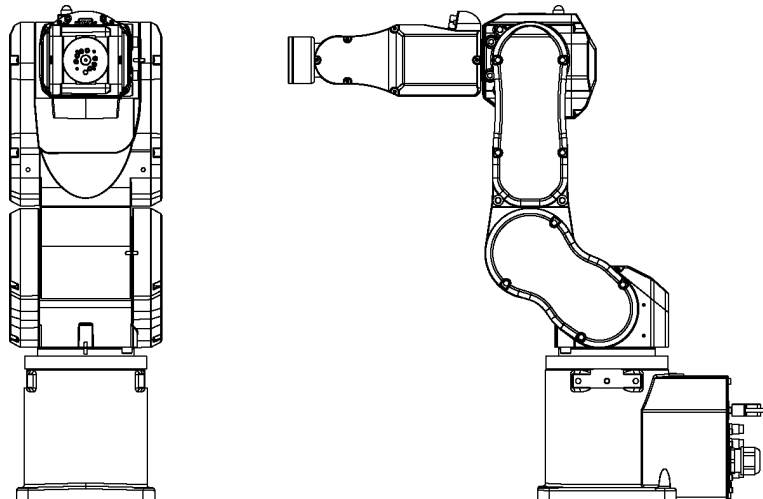

Basic orientation (0 pulse position)

4. End Effectors

4.1 Attaching an End Effector

Create an end effector for your Manipulator. For details of attaching an end effector, refer to “*Hand Function Manual*”

Flange dimensions of the wrist attached to the end of Arm #6 is as below.

 CAUTION	<ul style="list-style-type: none"> ■ If you use an end effector equipped with a gripper or chuck, connect wires and/or pneumatic tubes properly so that the gripper does not release the work piece when the power to the robot system is turned OFF. Improper connection of the wires and/or pneumatic tubes may damage the robot system and/or work piece as the work piece is released when the Emergency Stop switch is pressed. I/O outputs are configured at the factory so that they are automatically shut off (0) by power disconnection, the Emergency Stop switch, or the safety features of the robot system. However, the I/O set in the hand function does not turn off (0) when the Reset command is executed or in emergency stop.
---	---

Wrist Flange

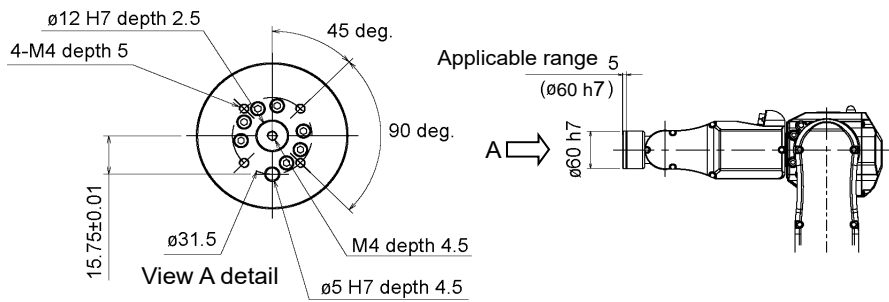

Arm #6

Attach an end effector to the end of the Arm #6 using the M4 bolts.

Layouts

When you operate the Manipulator with an end effector, the end effector may interfere with the Manipulator body depending on the outer diameter of the end effector, the size of the work piece, or the position of the arms. When designing your system layout, pay close attention to the interference area of the end effector.

Compatibility with PS series or ISO Standard:

To install the end effector used in the PS series or the end effectors which has flange conforming to ISO standard to the C4 series, we provide the optional PS Compatible Plate. For details, refer to “6. Options”.

4.2 Attaching Camera and Air Valves

Decks are equipped to Arms #3 and #5 to enable the easy installation of air valve.

If the payload exceeds the maximum payload, refer to the section “*Restriction on payload exceeding the maximum payload*” in “4.3.1 WEIGHT Setting”.

To mount the camera, the camera plate unit is necessary.

We provide the optional Camera Plate Unit. For details, refer to “6. Options”.

[Unit: mm]

C4-A601**

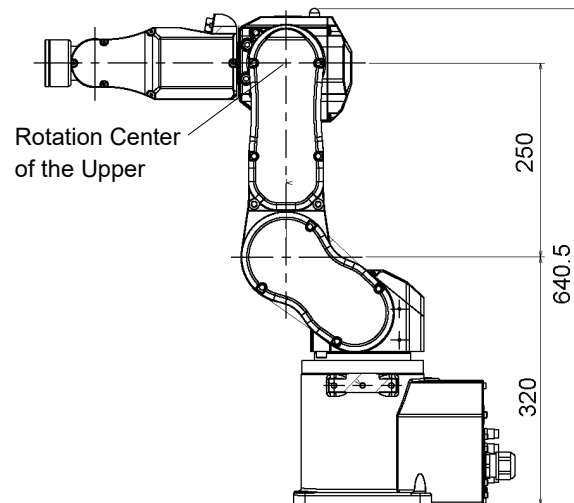
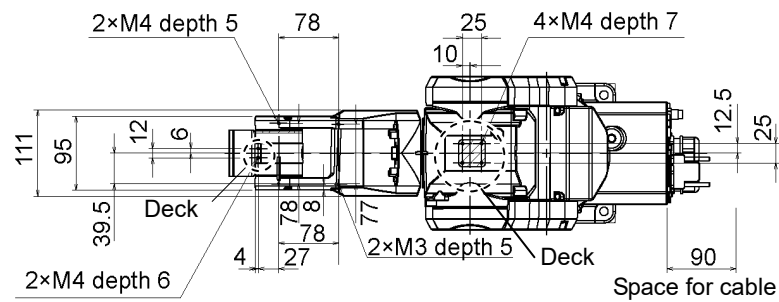

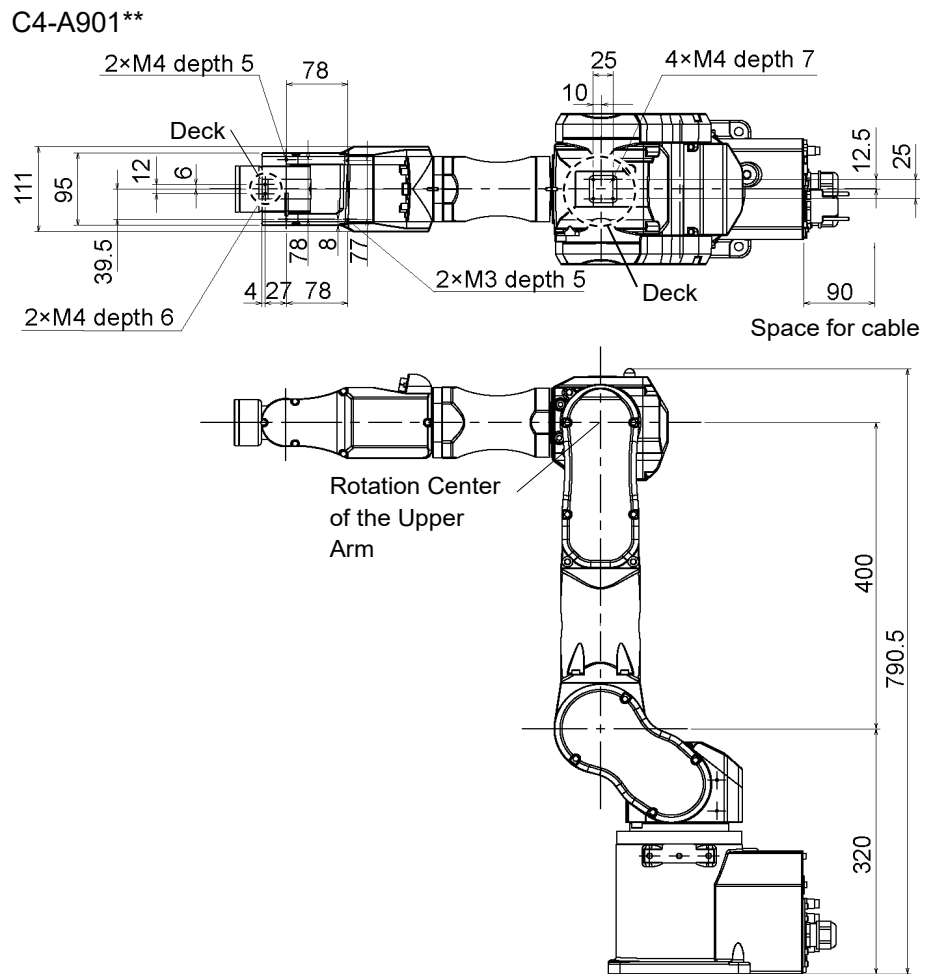

4.3 WEIGHT and INERTIA Settings

The WEIGHT and INERTIA commands are for setting the load parameters of the Manipulator. These settings optimize the Manipulator motion.

WEIGHT Setting

The WEIGHT command is for setting the load weight. The more the load weight increases, the more the speed and acceleration/deceleration are reduced.

INERTIA Setting

The INERTIA command is for setting the inertia moment and the eccentricity of the load. The more the inertia moment increases, the more the acceleration and deceleration of the Arm #6 are reduced. The more the eccentricity increases, the more the acceleration and deceleration for the Manipulator movement are reduced.

To ensure optimum Manipulator performance, make sure that the load (weight of the end effector and work piece) and inertia moment of the load are within the maximum rating for the Manipulator, and that Arm #6 does not become eccentric.

If the load or the inertia moment exceeds the ratings or if the load becomes eccentric, follow the steps in “4.3.1 WEIGHT Setting” and “4.3.2 INERTIA Setting”, to set parameters.

Setting parameters makes the operation of the Manipulator optimal, reduces vibration to shorten the operating time, and improves the capacity for larger loads. In addition, it reduces persistent vibration produced when the inertia moment of the end effector and work piece is bigger.

You can also set by following “Weight, Inertia, and Eccentricity/offset Measurement Utility”. The following manual describes the details.

Epson RC+ User's Guide

6.18.12 Weight, Inertia, and Eccentricity/offset Measurement Utility

The allowable load for C4 series Manipulators is as follows:

Up to 4 (5) kg*

Due to the limitations shown in the tables below, the moment and the inertia moment should also meet these conditions.

If force is applied to the Manipulator instead of weight, it should not exceed the values shown in the table below.

* If the payload exceeds the maximum payload, refer to the section “Restriction on payload exceeding the maximum payload” in “4.3.1 WEIGHT Setting”.

Allowable Load

Joint	Allowable Moment	GD ² /4 Allowable Moment of Inertia
#4	4.41 N·m (0.45 kgf·m)	0.15 kg·m ²
#5 *	4.41 N·m (0.45 kgf·m)	0.15 kg·m ²
#6	2.94 N·m (0.3 kgf·m)	0.1 kg·m ²

* The allowable load for Arm #5 are calculated as follows:

Distance from the center of Arm #5 rotation (Figure: a + 65 [mm]).

Critical Dimension of Load

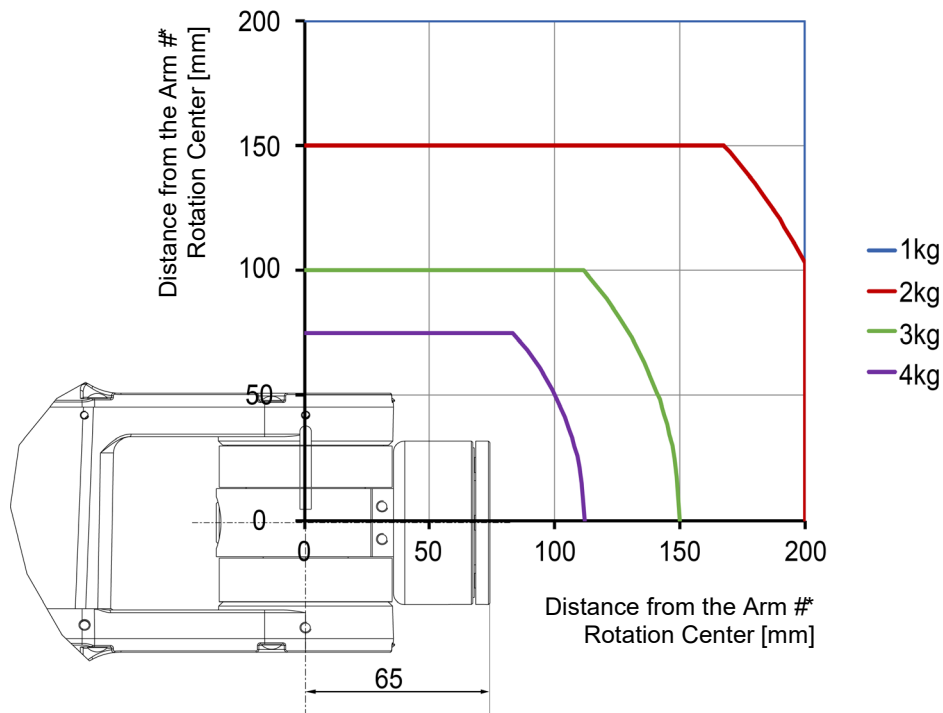
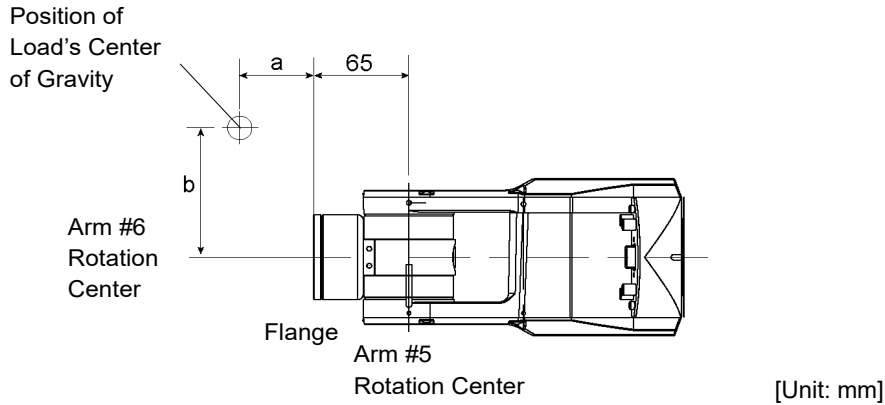

When calculating the critical dimension of the load on the Arm #6 using the allowable moment and inertia moment, the calculated value represents a distance from the Arm #5 rotation center, not the distance from the flange. Therefore, to get a value of the critical dimension of the load on Arm #5, subtract 65 (mm) from the calculated distance as shown in the example below.

Example: Calculate the critical dimension of the load on the Arm #5 (c) when a 2.5 kg load is on the Arm #6 rotation center line (b = 0).

$$\begin{aligned} & \text{Allowable Moment of the Arm \#5 (N}\cdot\text{m)} / \text{Load (kg)} \\ & = \text{Distance from the Arm \#5 rotation center (m)} \\ & 4.41 \text{ (N}\cdot\text{m)} / 9.8 / 2.5 \text{ (kg)} = 0.18 \rightarrow 0.18 \text{ (m)} = 180 \text{ (mm)} \end{aligned}$$

$$\begin{aligned} c &= \text{Distance from the Arm \#5 rotation center (mm)} - 65 \text{ (mm)} \\ c &= 180 \text{ (mm)} - 65 \text{ (mm)} = 115 \text{ (mm)} \end{aligned}$$

Moment

A moment is a necessary torque (holding torque) to counteract the gravity affecting the load. Design an end effector so that the eccentric quantity at the position where the load is attached is within the allowable moment.

A maximum torque (T) is calculated by the following formula.

$$T = m \text{ (kg)} \times L \text{ (m)} \times g \text{ (m/s}^2\text{)}$$

m: Weight of load (kg)

L: Eccentric quantity of load (m)

g: Gravitational acceleration (m/s²)

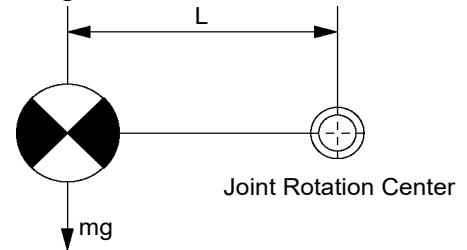

Max. Eccentric Quantity of Load

(Distance between the joint rotation center and the load's center of gravity)

Axis	WEIGHT 1 kg	WEIGHT 2 kg	WEIGHT 3 kg	WEIGHT 4 kg
#4	200 mm	200 mm	150 mm	112 mm
#5	200 mm	200 mm	150 mm	112 mm
#6	200 mm	150 mm	100 mm	75 mm

(The maximum eccentric quantity of load is restricted to 200 mm or less.)

4.3.1 WEIGHT setting

 CAUTION	<ul style="list-style-type: none"> ■ Set the total weight of the end effector and the work piece smaller than the maximum payload. The C4 Manipulators can operate without limitations on the condition unless and until the load exceeds this maximum payload. When the payload of the Manipulator exceeds the maximum payload, refer to the section “<i>Restrictions on payload exceeding the maximum payload</i>” in the later part of this section for details. Always set the Weight parameters of the WEIGHT command according to the load. Setting a value that is smaller than the actual load may cause errors, excessive shock, insufficient function of the Manipulator, and/or shorten the life cycle of parts/mechanisms.
--	---

The acceptable weight capacity (end effector and work piece) for C4 Manipulators is as follows:

Rated	Maximum
1 kg	4(5) kg*

When the load exceeds the rating, change the setting of the Weight parameter.

After changing the Weight parameter setting, the maximum acceleration/deceleration and speed of the robot system corresponding to the load is set automatically.

* If the payload exceeds the maximum payload, refer to the section “*Restriction on payload exceeding the maximum payload*” in the *Setup & Operation 4.3.1 WEIGHT Setting*.

Setting method of Weight parameters

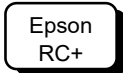

Select [Tools]-[Robot Manager]-[Weight] panel and set the value in [Weight:].
 You may also execute the Weight command from [Command Window].

Load on the Manipulator

Mounting location of the load

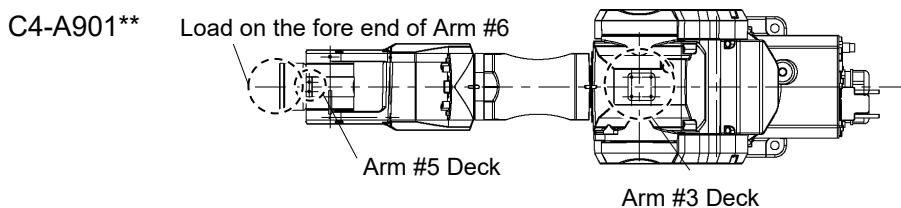
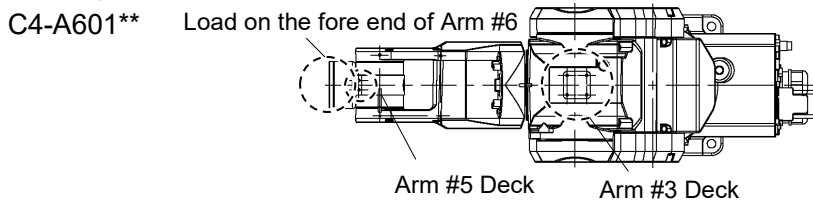

C4 series

Deck detailed

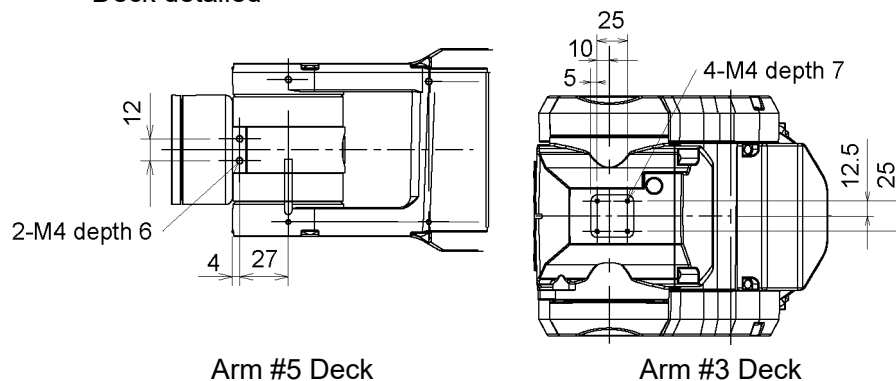

[Unit: mm]

When you attach the equipment to the decks on the upper arm, convert its weight into equivalent weight assuming that the equipment is attached to the end of the Arm #6. Then, this equivalent weight added to the load will be a Weight parameter.

Calculate the Weight parameter by using the formula below and enter the value.

Weight Parameter Formula

$$\text{Weight parameter} = M_w + W_a + W_b$$

M_w : Load on the fore end of Arm #6 (kg)

W_a : Equivalent weight of the Arm #3 deck (kg)

W_b : Equivalent weight of the Arm #5 deck (kg)

$$W_a = M_a (L_a)^2 / (L)^2$$

$$W_b = M_b (L_b)^2 / (L)^2$$

M_a : Weight of the air valve on the Arm #3 deck

M_b : Weight of the camera on the Arm #5 deck

L : Length of the upper arm (315 mm)

L_a : Distance between the Joint #3 and the center of gravity of the air valve on the Arm #3 deck (mm)

L_b : Distance between the Joint #3 and the center of gravity of the camera on the Arm #5 deck (mm)

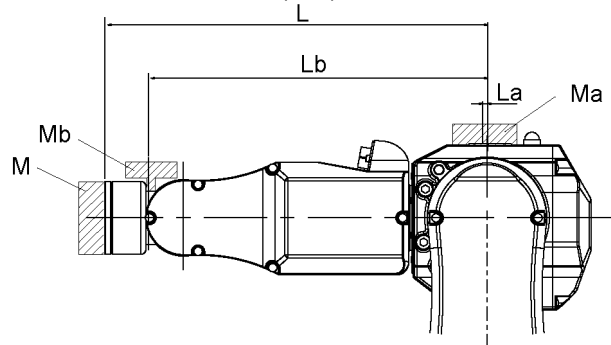

<Example> The fore end of the Arm #6 is 315 mm (L) away from the Joint #3.

Load on the fore-end of Arm #6 is 1 kg (M_w).

Load on the Arm #3 deck is 1.5 kg (M_a).

The deck is 0 mm (L_a) away from Joint #3.

Load on the Arm #5 deck is 0.5 kg (M_b).

The deck is 280 mm (L_b) away from the Joint #3.

$$W_a = 1.5 \times 0^2 / 315^2 = 0$$

$$W_b = 0.5 \times 280^2 / 315^2 = 0.395 \rightarrow 0.4 (\text{round up})$$

$$M_w + W_a + W_b = 1 + 0 + 0.4 = 1.4$$

Enter "1.4" for the Weight parameter.

Automatic speed setting by Weight parameter (C4-A601**)

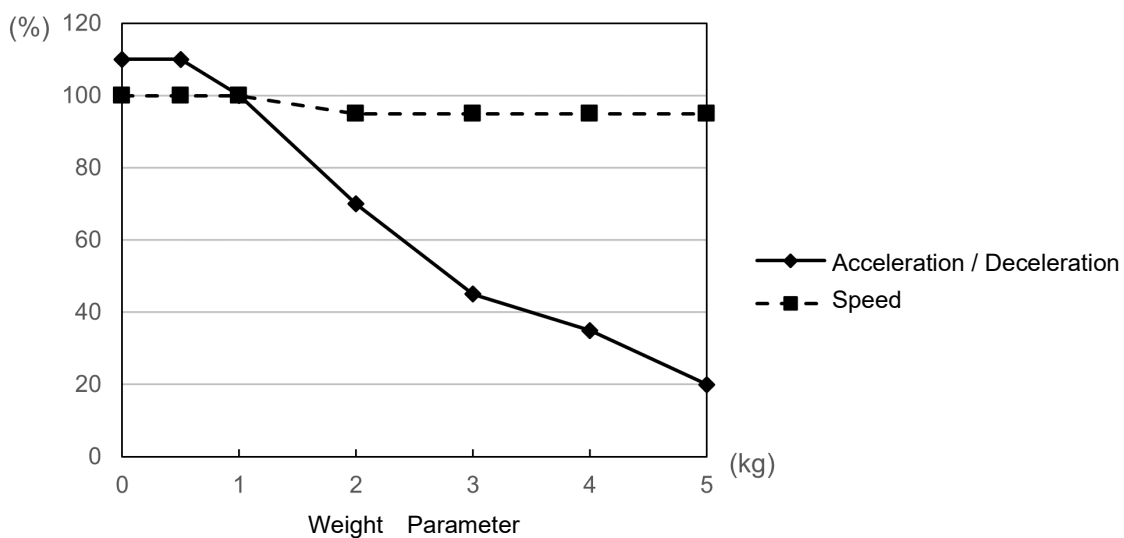

Automatic speed setting by Weight parameter (C4-A901**)

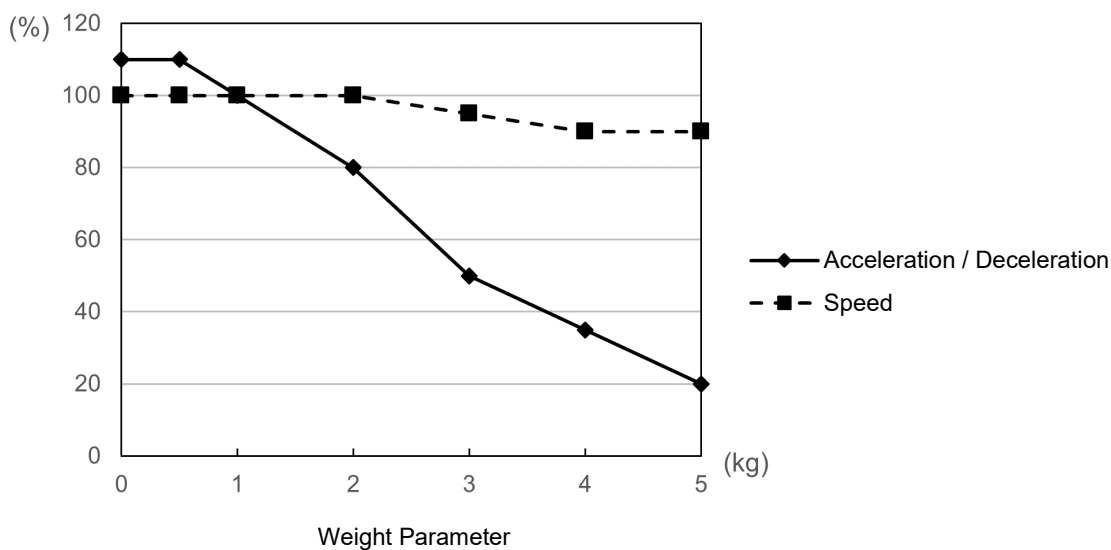

* The percentage in the graph is based on the speed at rated weight (1 kg) as 100%.

* If the payload exceeds the maximum payload, refer to the section “*Restriction on payload exceeding the maximum payload*” in “4.3.1 WEIGHT Setting”.

Restrictions on payload exceeding the maximum payload

Maximum payload for C4 Manipulators is as follows:

Payload can be increased by restricting the arm posture of the Arm #5 downward.

Max. Payload	Max. Payload with Pose Restriction
4 kg	5 kg

If the load exceeds the maximum payload, use the Arm #5 with a posture angle within the range indicated in the following graph.

The graph shows the relation of the load weight and Arm #5 angle limit (A^1) measured in vertical direction (direction of gravity). Note that the heavier the load on the Arm #6, the smaller the angle limit becomes.

When the Manipulator operates vertically to the operating surface, the limit of the Arm #5 is equivalent to the limit of the operating angle (A^2).

In addition, for the eccentric load, the angle limit is an angle of the line joining the center of the load and the Arm #5 rotation axis with the vertical direction (B).

The eccentric quantity of the load should be within the allowable moment and inertia moment of Arms #4, #5, and #6.

Relation of load weight and Arm #5 angle limit

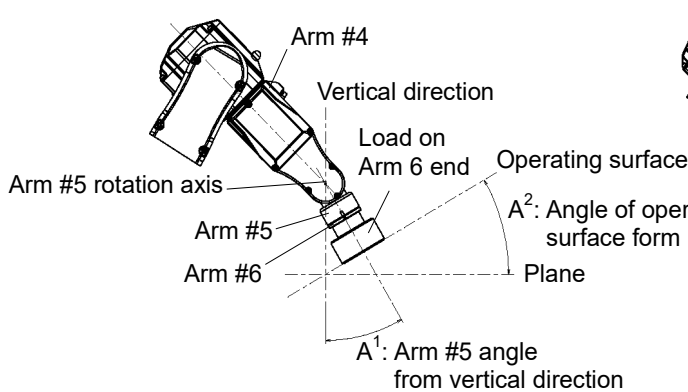
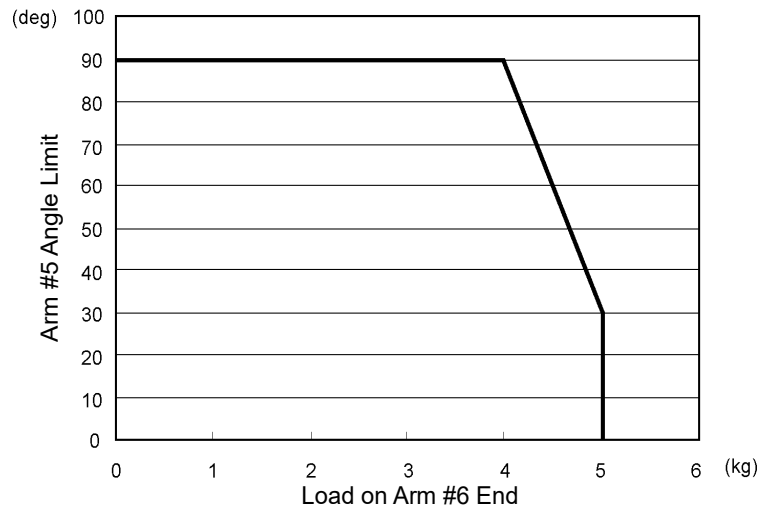

Relation of Arm #5 angle and operating surface

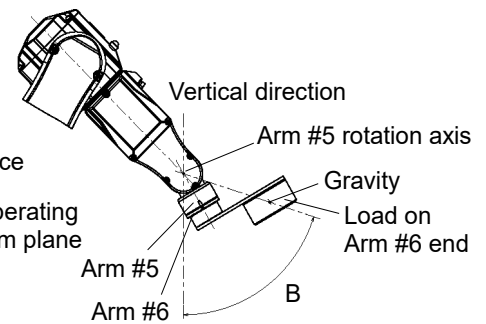

Angle limit for eccentric load

4.3.2 INERTIA setting

Inertia Moment and the INERTIA Setting

The inertia moment is defined as “the ratio of the torque applied to a rigid body and its resistance to motion”. This value is typically referred to as “the moment of inertia”, “inertia”, or “GD²”. When the Manipulator operates with objects such as an end effector attached to the Arm #6, the moment of inertia of load must be considered.



CAUTION

- The inertia moment of the load (weight of the end effector and work piece) must be 0.1 kg·m² or less. The C4 Manipulators are not designed to work with inertia moment exceeding 0.1 kg·m².
Always set the inertia moment (INERTIA) parameter according to the inertia moment. Setting a value that is smaller than the actual inertia moment may cause errors, excessive shock, insufficient function of the Manipulator, and/or shorten the life of parts/mechanisms.

The acceptable inertia moment of load for C4 Manipulator is 0.005 kg·m² nominal rating and 0.1 kg·m² maximum. When the inertia moment of the load exceeds the rating, change the setting of the inertia moment using the INERTIA command. After the setting has been changed, the maximum acceleration/deceleration speed of Arm #6 responding to “inertia moment” is set automatically.

Inertia moment of load on Arm #6

The inertia moment of the load (weight of the end effector and work piece) on the Arm #6 can be set by the “inertia moment (INERTIA)” parameter of the INERTIA command.

Epson
RC+

Select [Tools]-[Robot Manager]-[Inertia] panel and enter the value in [Load inertia:].
You may also execute the Inertia command from [Command Window].

Eccentric Quantity and the INERTIA Setting



- The eccentric quantity of the load (weight of the end effector and work piece) must be 200 mm or less. The C4 Manipulators are not designed to work with eccentric quantity exceeding 200 mm. Always set the eccentric quantity parameter according to the eccentric quantity. Setting a value that is smaller than the actual eccentric quantity may cause errors, excessive shock, insufficient function of the Manipulator, and/or shorten the life cycle of parts/mechanisms.

The acceptable eccentric quantity of the load for C4 Manipulators is 30 mm at nominal rating and 200 mm at maximum. When the eccentric quantity of the load exceeds the rating, change the setting of eccentric quantity parameter using the INERTIA command. After changing the setting, the maximum acceleration/deceleration speed of Manipulator corresponding to “eccentric quantity” is set automatically.

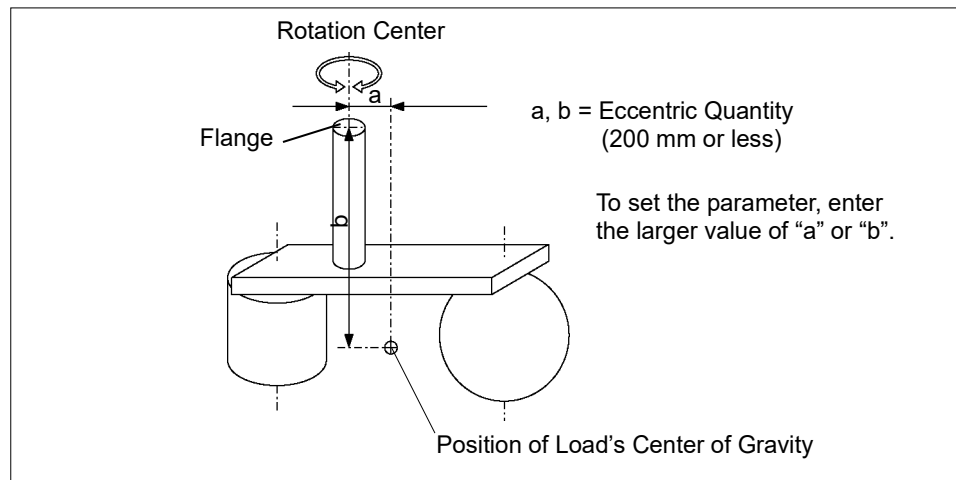

Eccentric Quantity

Eccentric quantity of load on Arm #6

The eccentric quantity of the load (weight of the end effector and work piece) on the Arm #6 can be set by the “eccentric quantity” parameter of the INERTIA command. Enter the larger value of either “a” or “b” in the figure above to [Eccentricity].

Epson
RC+

Select [Tools]-[Robot Manager]-[Inertia] panel and enter the value into [Eccentricity:]. You may also execute the Inertia command from [Command Window].

Automatic acceleration/deceleration setting by INERTIA (eccentric quantity)

Automatic setting by inertia moment setting

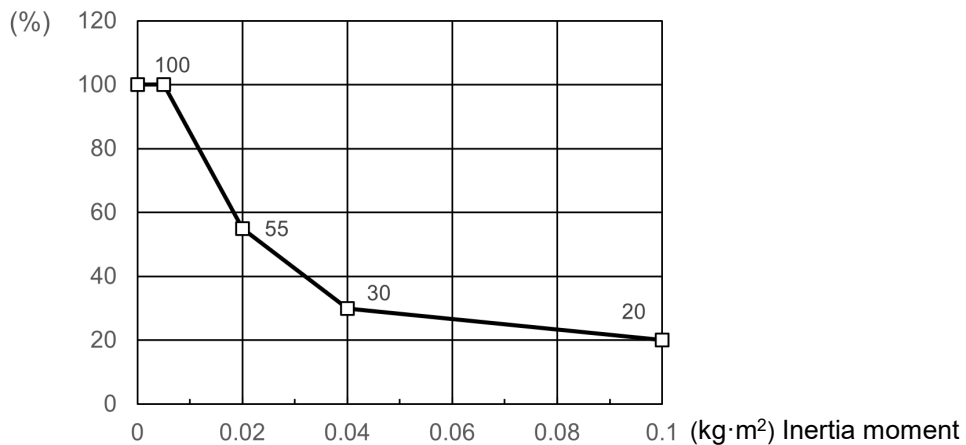

* The percentage in the graph is based on the acceleration/ deceleration at rated eccentricity (0.005 kg·m²) as 100%.

Automatic setting by eccentricity setting

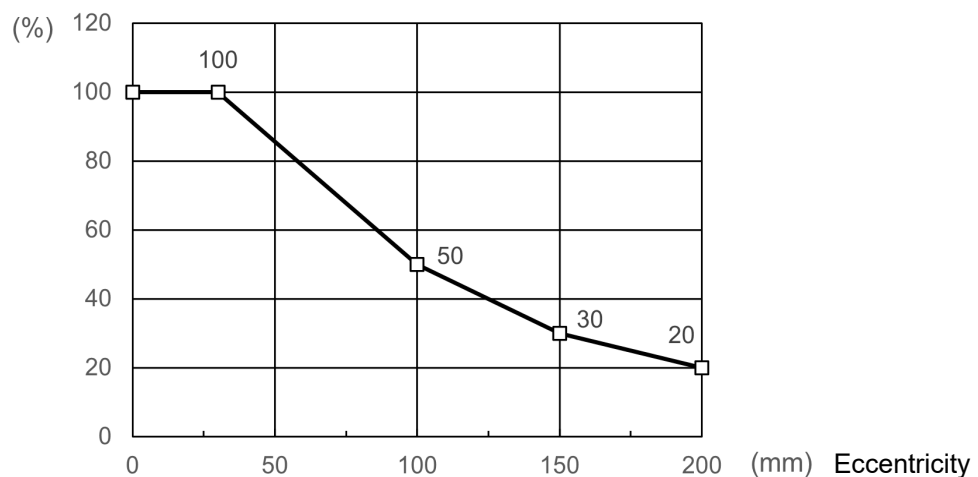

* The percentage in the graph is based on the acceleration/ deceleration at rated eccentricity (30 mm) as 100%.

INERTIA (eccentric quantity) is affected by the load setting. Refer to *Setup & Operation 4.3: WEIGHT and INERTIA Settings* and configure the load setting carefully.

Calculating the Inertia Moment

Refer to the following example formulas to calculate the inertia moment of the load (end effector with work piece).

The inertia moment of the entire load is calculated by the sum of (a), (b), and (c).

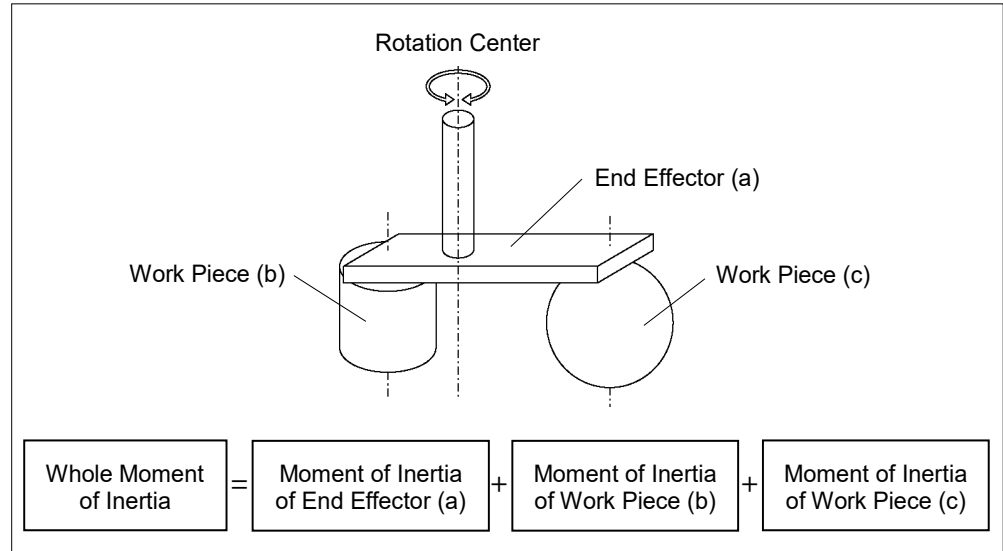

The methods for calculating the inertia moment for (a), (b), and (c) are shown in this and the next page. Figure out the whole inertia moment using the basic formulas below.

(a) Inertia moment of a rectangular parallelepiped

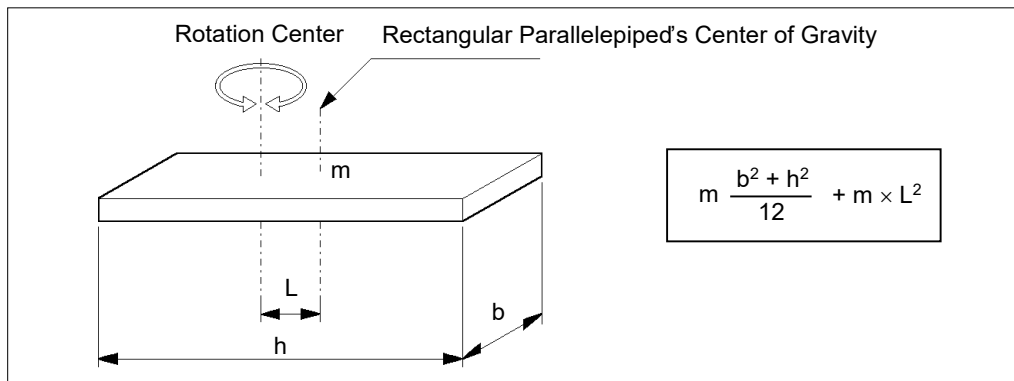

(b) Inertia moment of a cylinder

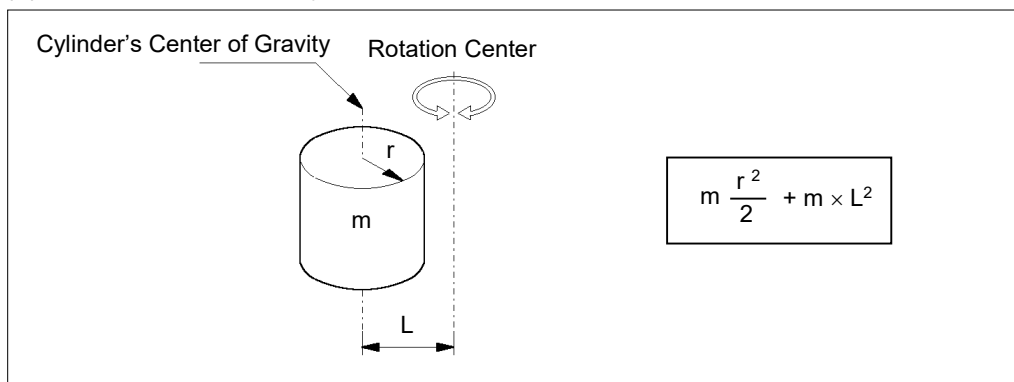

(c) Inertia moment of a sphere

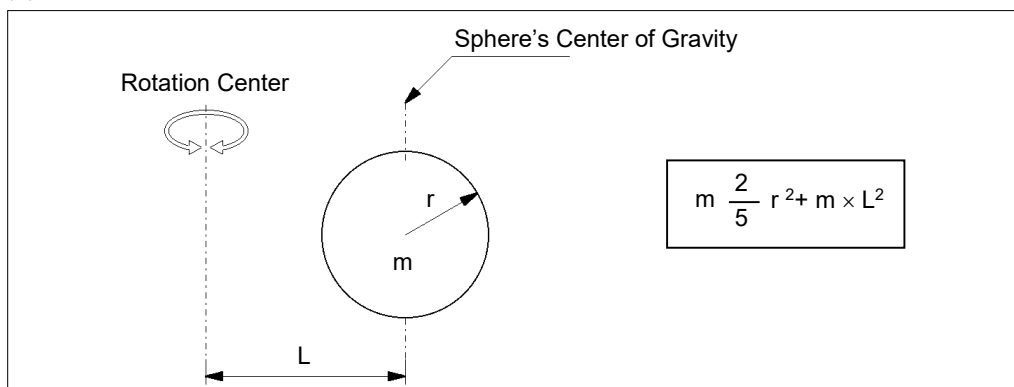

4.4 Precautions for Auto Acceleration/Deceleration

The speed and acceleration/deceleration of the Manipulator motion are automatically optimized according to the values of WEIGHT and INERTIA and the Manipulator's postures.

WEIGHT Setting

The speed and acceleration/deceleration of the Manipulator are controlled according to the load weight set by the WEIGHT command.

The more the load weight increases, the more the speed and acceleration/deceleration are reduced to prevent residual vibration.

INERTIA Setting

The acceleration/deceleration of Arm #6 are controlled according to the inertia moment set by the INERTIA command. The acceleration/deceleration of the whole Manipulator are controlled according to the eccentricity set by the INERTIA command. The more the inertia moment and eccentricity of the load increase, the more the acceleration/deceleration are reduced.

Auto Acceleration/Deceleration According to Manipulator's Posture

The acceleration/deceleration are controlled according to the Manipulator's posture. When the Manipulator extends its arms or when the movement of the Manipulator produces vibration frequently, the acceleration/deceleration are reduced.

Set appropriate values for WEIGHT and INERTIA so that the Manipulator operation is optimized.

5. Motion Range



WARNING

- When limiting the motion range for safety, be sure to set by both the pulse range and mechanical stops. Failure to do so may cause serious safety problems.

The motion range is preset at the factory as describes in “2.5 *Standard Motion Range*”. This is the maximum motion range of the Manipulator.

Motion range is set by the following three methods:

1. Setting by pulse range (for all arms)
2. Setting by mechanical stops
3. Setting the Cartesian (rectangular) range in the X, Y coordinate system of the Manipulator

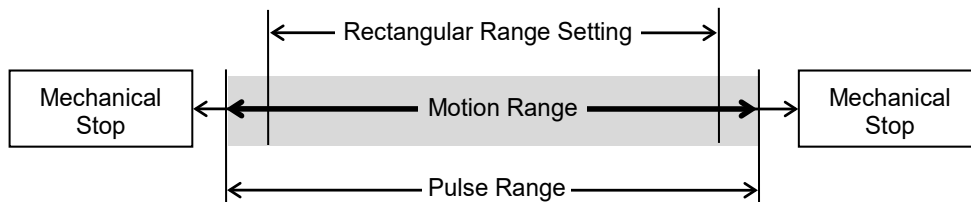

When the motion range is changed due to layout efficiency or safety, follow the descriptions in 5.1 through 5.4 to set the range.

5.1 Motion Range Setting by Pulse Range (for All Arms)

Pulses are the basic unit of Manipulator motion. The motion range of the Manipulator is controlled by the pulse range (the lower limit and the upper limit) of each axis.

Pulse values are read from the encoder output of the servo motor.

The pulse range should be set within the mechanical stop range.



- Do not set and/or use the Arm #4 with a pulse range exceeding the maximum value.
The Arm #4 does not have a mechanical stop. Using the Arm #4 with a pulse range exceeding the maximum pulse range may cause the inner wiring damaged and/or malfunction to the Manipulator.

Torsion of the inner wiring can be checked by removing the Arm #3 head cover.

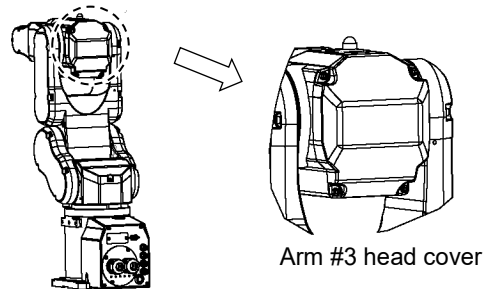

Once the Manipulator receives an operating command, it checks whether the target position specified by the command is within the pulse range before operating. If the target position is out of the set pulse range, an error occurs and the Manipulator does not move.



The pulse range can be set in [Tools]-[Robot manager]-[Range] panel.
You may also execute the Range command from the [Command Window].

5.1.1 Max. Pulse Range of Arm #1

Pulse values in counterclockwise direction are positive (+) and values in clockwise direction are negative (-).

C4-A601**

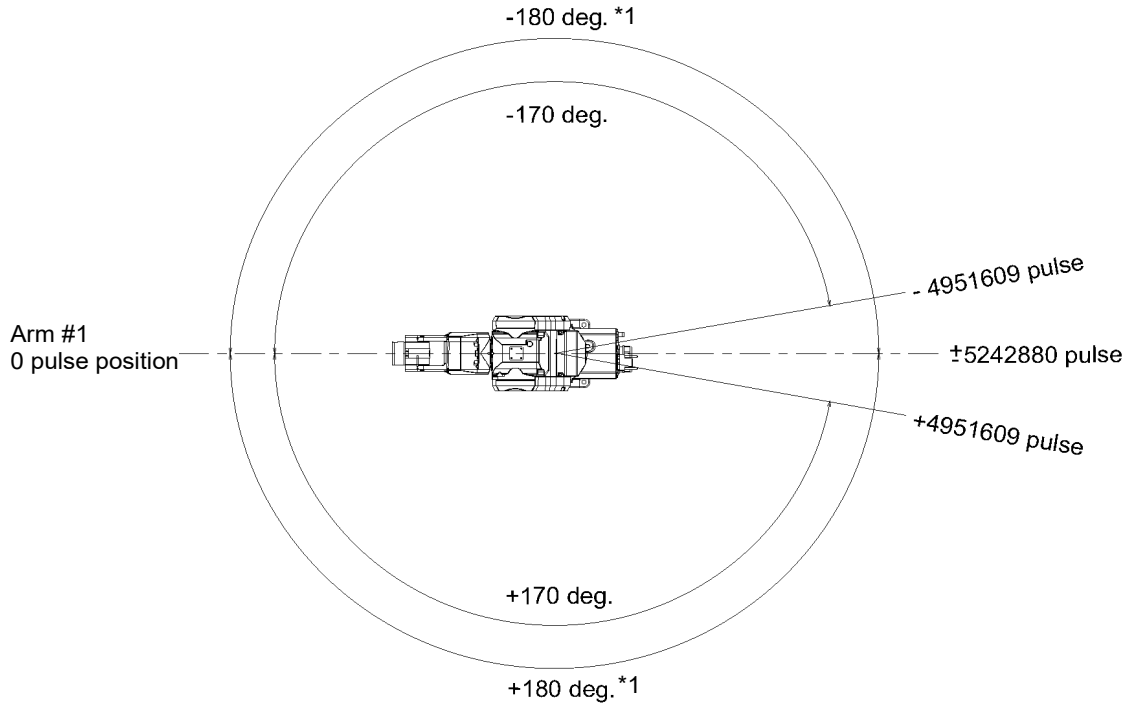

C4-A901**

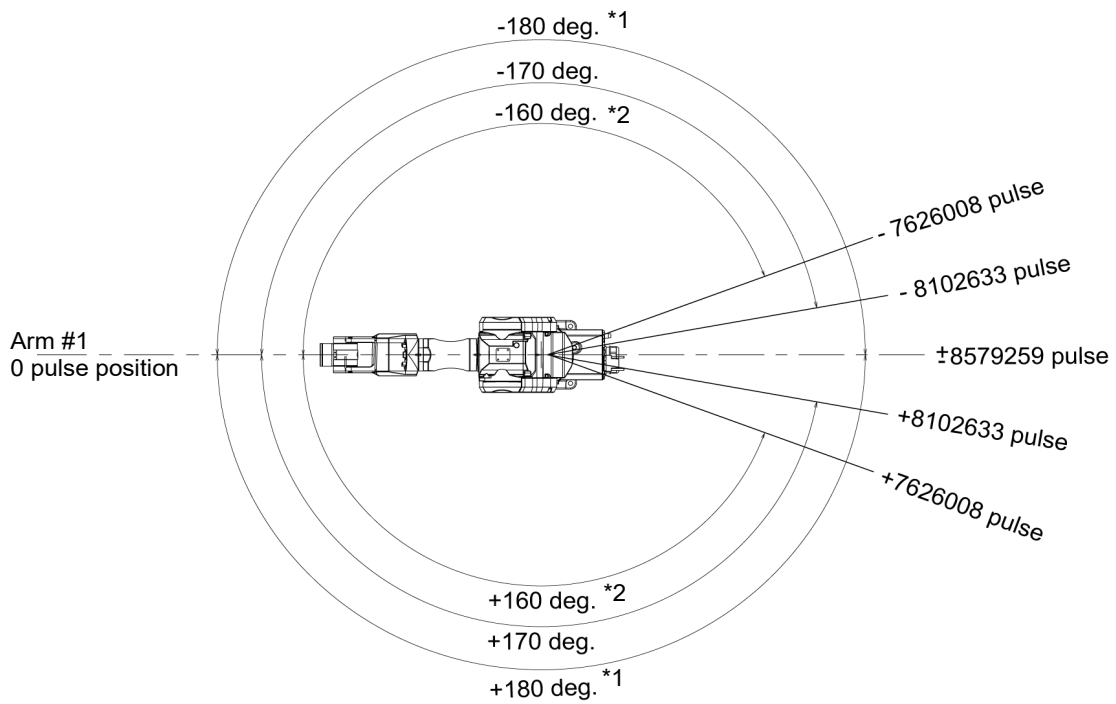

*1 without mechanical stop
*2 UL Specification

5.1.2 Max. Pulse Range of Arm #2

Pulse values in clockwise direction are positive (+) and values in counterclockwise direction are negative (-).

C4-A601**

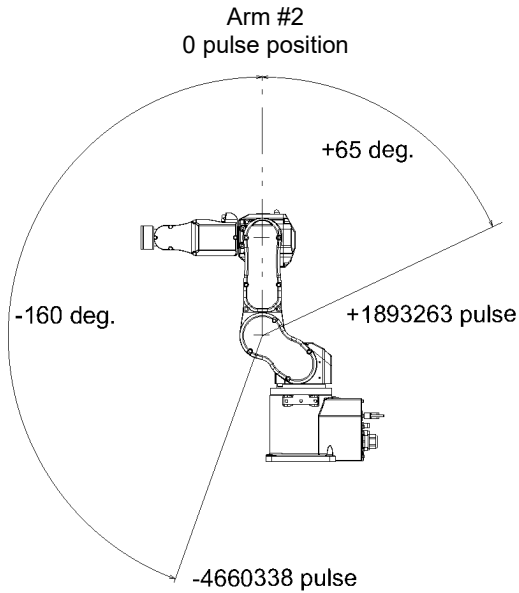

C4-A901**

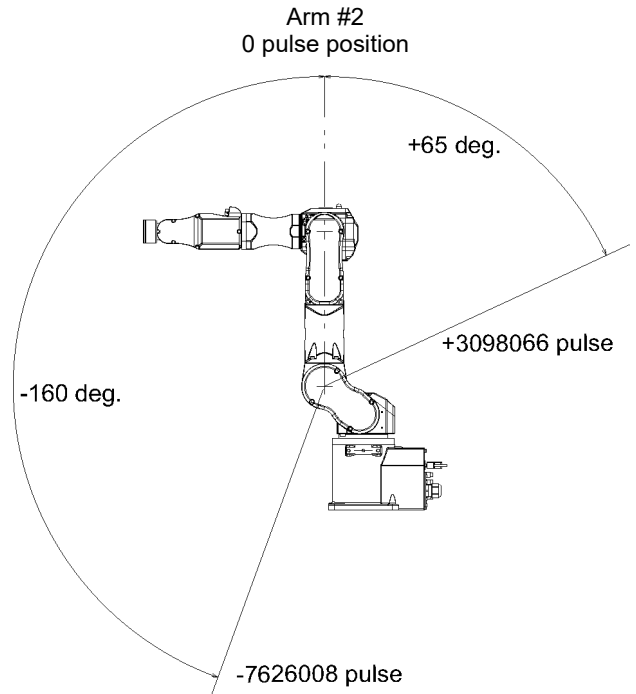

5.1.3 Max. Pulse Range of Arm #3

Pulse values in clockwise direction are positive (+) and values in counterclockwise direction are negative (-).

C4-A601**

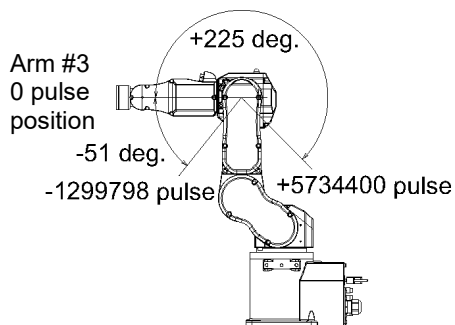

C4-A901**

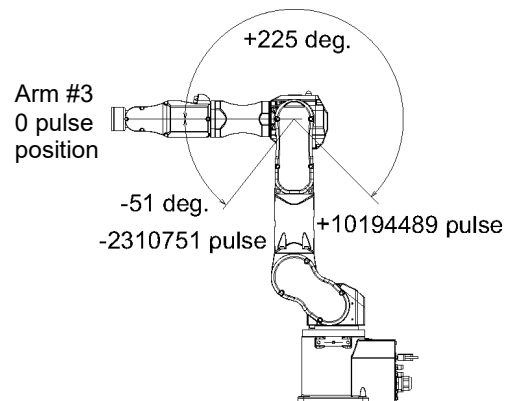

5.1.4 Max. Pulse Range of Arm #4

From the angle of arm end, clockwise pulse values are positive (+) and counterclockwise pulse values are negative (-).

C4-A601**

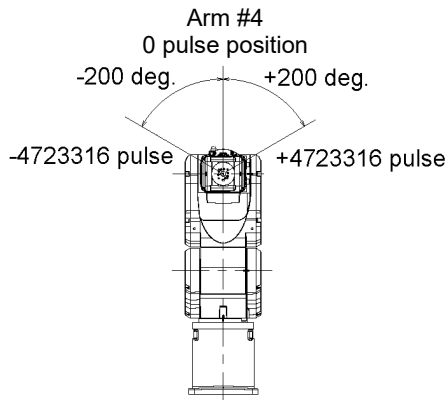

C4-A901**

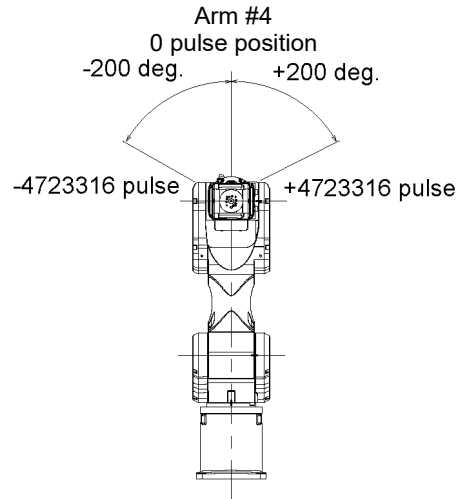

CAUTION

- Do not set and/or use the Arm #4 with a pulse range exceeding the maximum value. The Arm #4 does not have a mechanical stop. Using the Arm #4 with a pulse range exceeding the maximum pulse range may cause the inner wiring damaged and/or malfunction to the Manipulator.

Torsion of the inner wiring can be checked by removing the Arm #3 head cover.

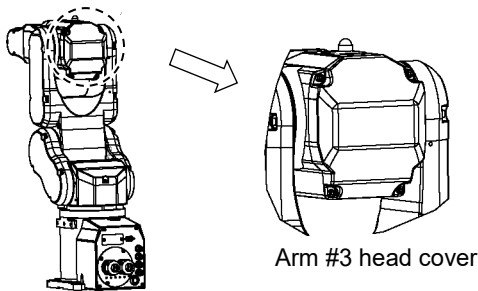

5.1.5 Max. Pulse Range of Arm #5

Pulse values in clockwise direction are positive (+) and values in counterclockwise direction are negative (-).

C4-A601**

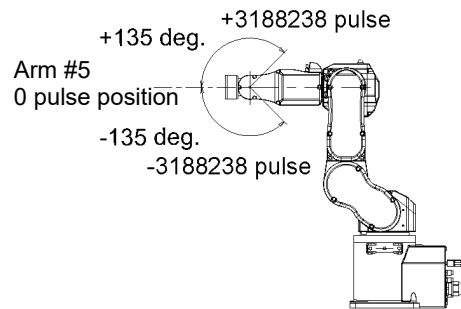

C4-A901**

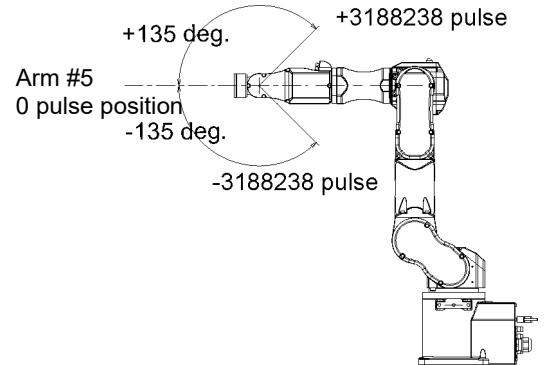

5.1.6 Max. Pulse Range of Arm #6

From the angle of arm end, clockwise pulse values are positive (+) and counterclockwise pulse values are negative (-).

C4-A601**

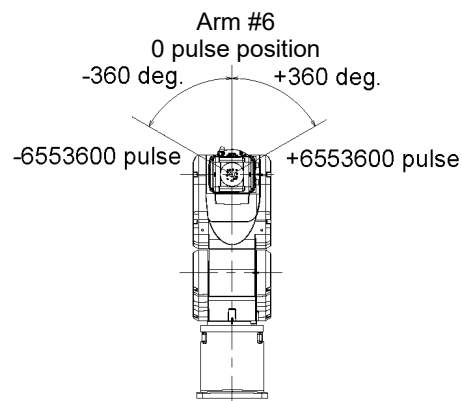

C4-A901**

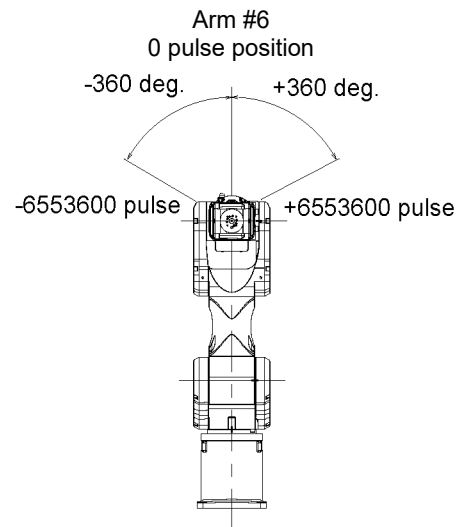

5.2 Motion Range Setting by Mechanical Stops

Mechanical stops physically limit the absolute area that the Manipulator can move.

Be sure to turn OFF the Controller in advance.

Use bolts conforming to the specified length and surface processing (ex: nickel plating) with high corrosion resistance.

Specify the pulse range again after changing the position of the mechanical stop.

For details on the pulse range setting, refer to “5.1 Motion Range Setting by Pulse Range (for All Arms)”.

Be sure to set the pulse range not to exceed the setting angles of the mechanical stop.

5.2.1 Motion Range Setting of Arm #1

Install the bolt to the threaded hole corresponding to the angle you want to set.

Normally a mechanical stop is equipped at [b].

[a] and [c] limit the one side of motion range.

Remove the bolts when the motion range of the Arm #1 is set to $\pm 180^\circ$.

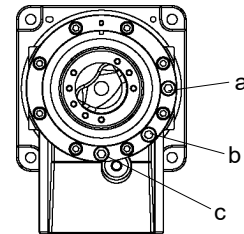

- M8×15 hexagon socket head cap bolt
- Strength Equivalent to ISO898-1 property class 10.9 or 12.9
- Tightening torque 32.0 N·m(326 kgf·cm)

	a	b		c
Angle (°)	-125	± 170	± 180	+125
Pulse (pulse)	C4-A601**	-3640889	± 4951609	± 5242880
	C4-A901**	-5957819	± 8102633	± 8579259
	C4-A901**-UL		± 7626008	
Bolt	Applied	Applied (standard)	Not applied	Applied

Mechanical stop for UL specification

There is a specified mechanical stop for UL specification.

Mount the mechanical stop as shown in the figure below.

C4

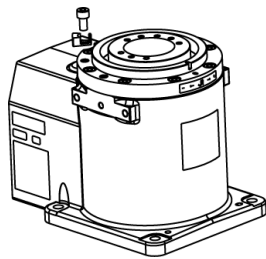

C4L

The setting angle differs from the non-UL compliant model. (refer to the above table)

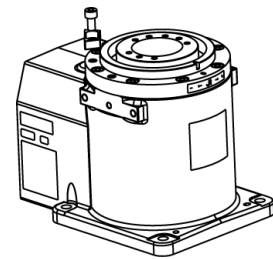

5.2.2 Motion Range Setting of Arm #2

There are threaded holes corresponding to each angle on the Manipulator.

Normally there is no mechanical stop equipped.
(-160 to +65°)

[d] and [e] limit the one side of motion range.

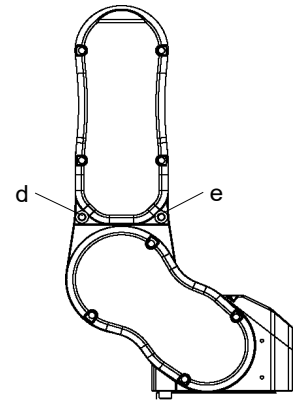

C4-A601**

M8×15 hexagon socket head cap bolt

Strength Equivalent to ISO898-1 property class 10.9 or 12.9

Tightening torque 32.0 N·m(326 kgf·cm)

	d	e	-	-
Angle (°)	-143	+48	-160	+65
Pulse (pulse)	-4165177	+1398102	-4660338	+1893263
Bolt	Applied	Applied	Not applied (standard)	Not applied (standard)

For C4-A901**, please contact the supplier of your region.

5.2.3 Motion Range Setting of Arm #3

There are threaded holes corresponding to each angle on the Manipulator.

Normally mechanical stops are equipped to [f] and [g].
(+225° to -51°)

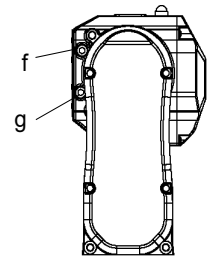

C4-A601**, C4-A901**

M8×12 hexagon socket head cap bolt

Strength Equivalent to ISO898-1 property class 10.9 or 12.9

Tightening torque 32.0 N·m(326 kgf·cm)

		f	g
Angle (°)		+225	-51
Pulse (pulse)	C4-A601**	+5734400	-1299798
	C4-A901**	+10194489	-2310751
Bolt		Applied (standard)	Applied (standard)

5.3 Restriction of Manipulator Operation by Joint Angle Combination

To prevent the arms of the Manipulator from interfering each other, the Manipulator operation is restricted in the specified motion range according to the joint angle combination of the Arm #1, #2, and #3.

The Manipulator operation is restricted and the Manipulator stops when the joint angles of the Arm are within the gray areas in the following figure.

The restriction to Manipulator operation is enabled:

- During CP motion command execution
- When you attempt to execute the motion command for moving the Manipulator to a target point (or pose) in the specified motion range.

The restriction to the Manipulator operation is disabled:

- The Arms of the Manipulator momentarily go through the specified motion range during the PTP motion command execution even though the joint angles of the Arms are in the gray areas of the figures above.

(deg.=°)

Combination of Joint #1 and #2 (C4-A601**)

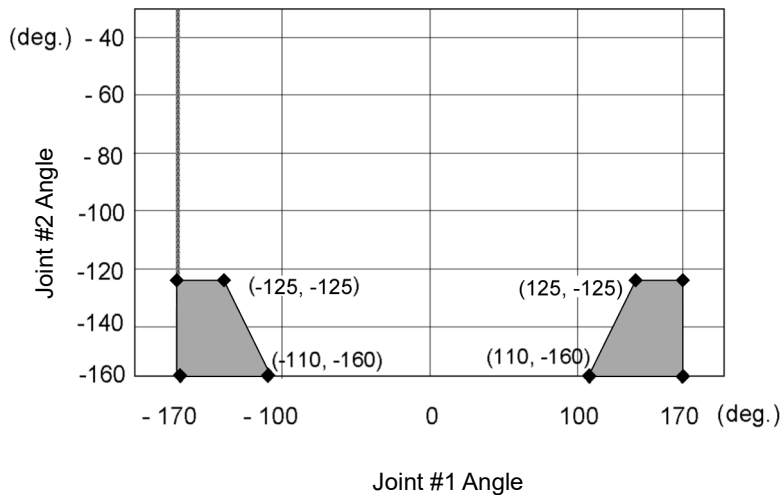

Combination of Joint #2 and #3 (C4-A601**)

-135 deg. <= J1 <= 135 deg.

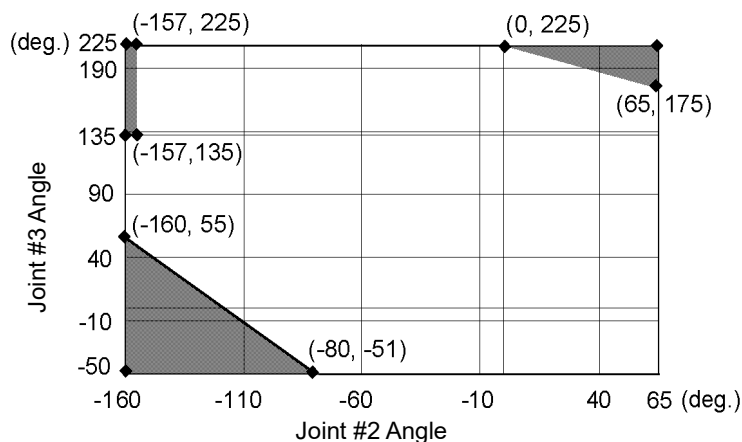

-170 deg. \leq J1 < -135 deg., 135 deg. < J1 \leq 170 deg.

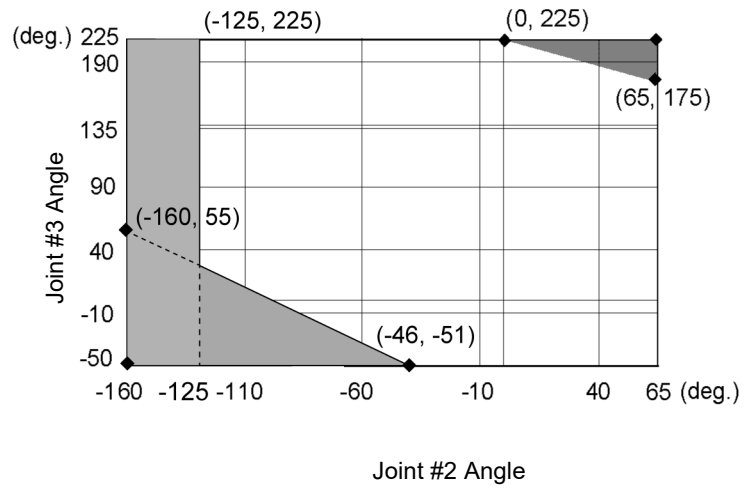

Combination of Joint #1 and #2 (C4-A901**)

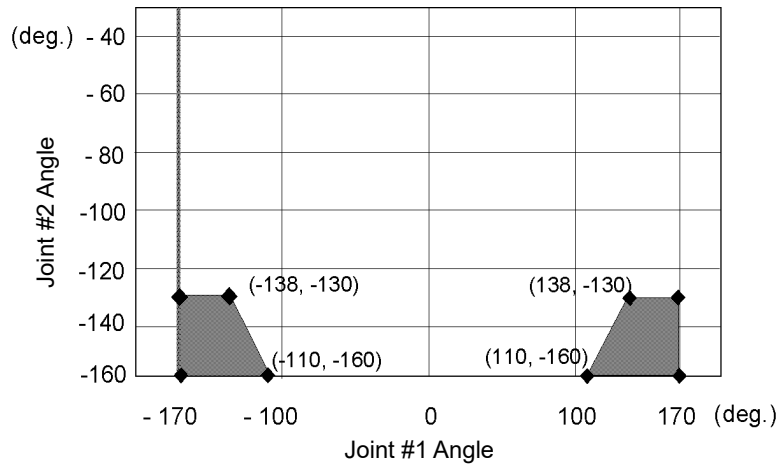

Combination of Joint #1 and #2 (C4-A901**-UL)

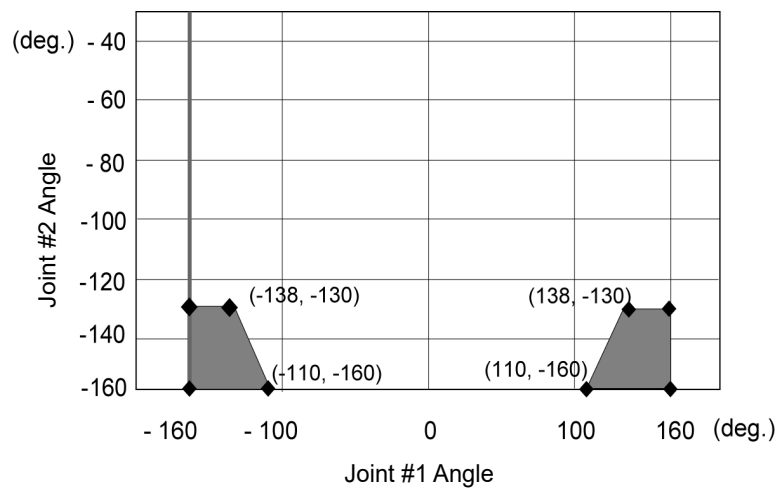

Combination of Joint #2 and #3 (C4-A901**)

-138 deg. \leq J1 \leq 138 deg.

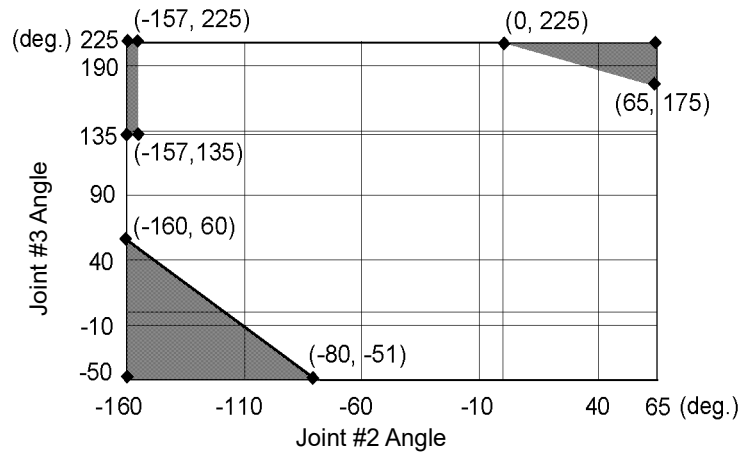

-170 deg. \leq J1 $<$ -138 deg., 138 deg. $<$ J1 \leq 170 deg.

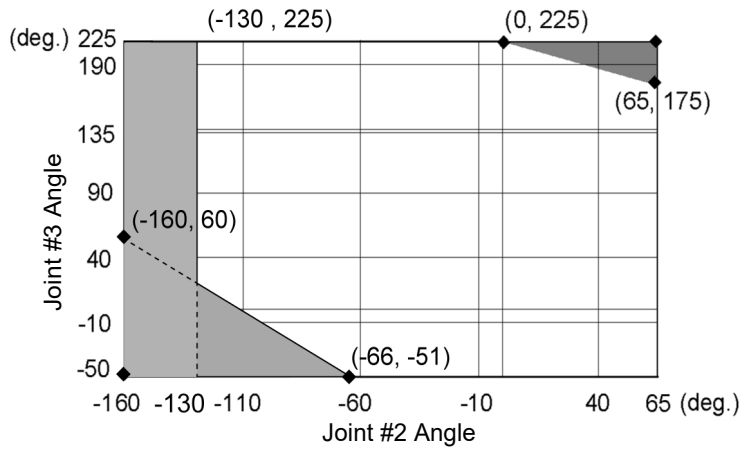

5.4 Coordinate System

The origin point is where the Manipulator base intersects with the rotation axis of Joint #1.
For details on the coordinate system, refer to the *Epson RC+ Users Guide manual*.

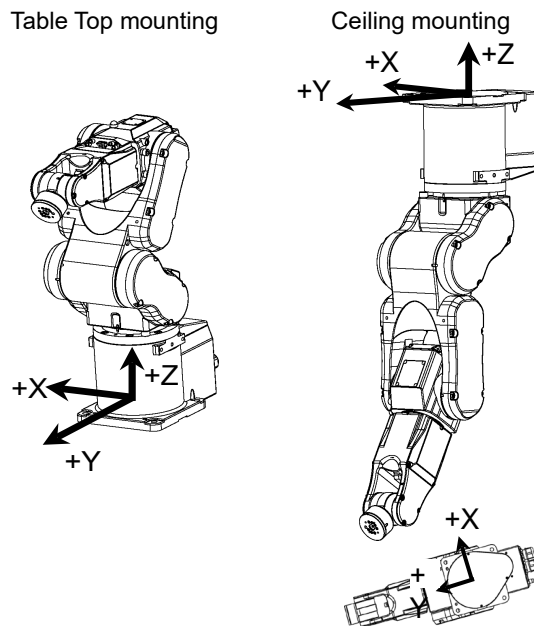

BASE setting is suitable for install the robot obliquely.

BASE setting can change a specific coordinate system of the robot and match the World coordinate system of the Jog & Teach and the coordinate system of the equipment.

For procedure of the BASE setting, refer to *SPEL+ Language Reference: BASE Command*.

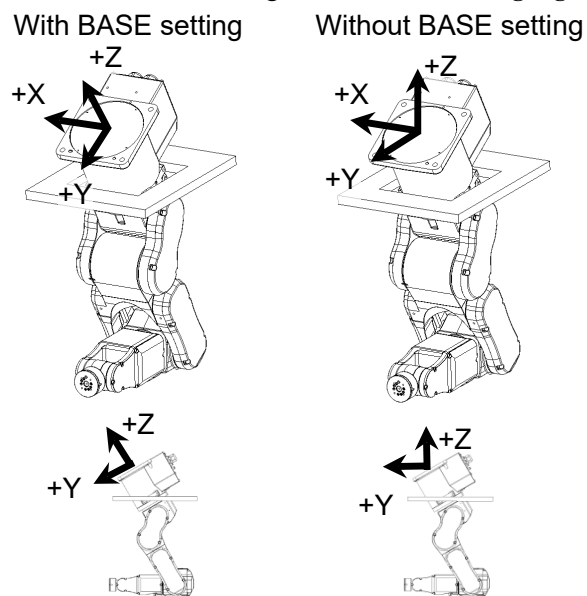

5.5 Changing the Robot

This section describes how to change the Manipulator model on Epson RC+. (Default setting is “table top mounting”.)



CAUTION

- Changing the Manipulator should be done with great caution. It initializes the robot calibration parameters (Hofs, CalPIs), additional axis information, and PG parameter data. Before changing the robot, make sure to save the calibration data by following the procedure below.
 1. Select the Epson RC+ menu-[Setup]-[System Configuration].
 2. Select [Controller]-[Robots]-[Robot**]-[Calibration] from the tree list. Then, click [Save].

- (1) Select the Epson RC+ menu-[Setup]-[System Configuration].
- (2) Select [Controller]-[Robots]-[Robot**] from the tree list. (Dialog image: Epson RC+ 8.0)

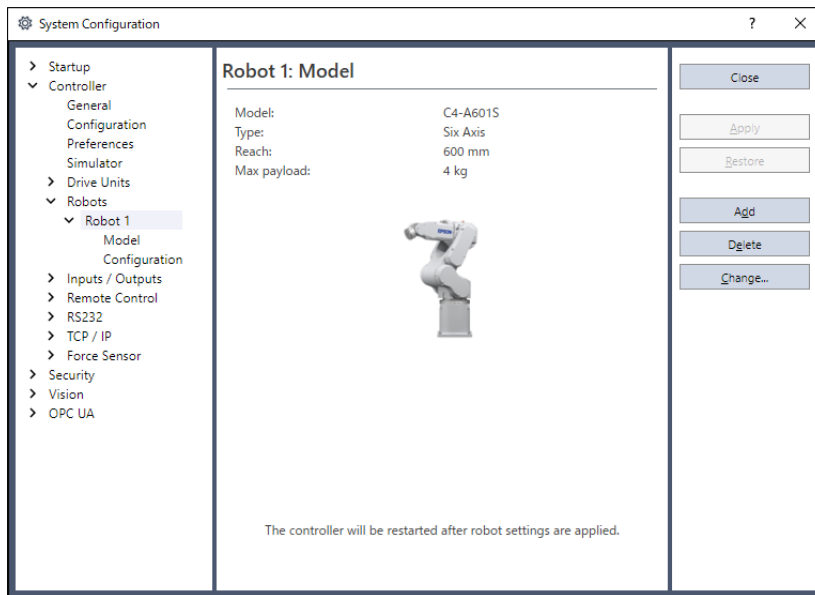

- (3) Click the [Change...] button. The following dialog box will be displayed.

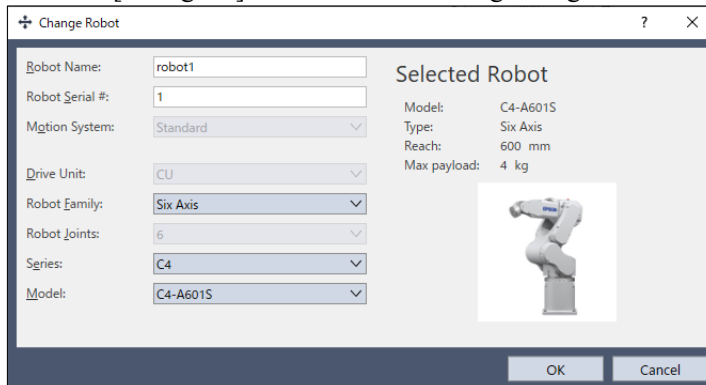

- (4) Input the robot name and serial number printed on the name plate of the Manipulator. Any serial number can be entered. However, enter the number printed on the Manipulator.

- (5) Select the robot type in the [Robot type] box.
- (6) Select the series name of the Manipulator in the [Series] box.
- (7) Select the robot model in the [Model] box. Available robots will be displayed according to the format of the currently installed motor driver. When [Dry run] is used, all the Manipulators of the series selected in Step 6 will be displayed.
For the ceiling mount type, select the model which ends with “R” (e.g. C4-A601SR).
- (8) Click the [OK] button. The Controller will be restarted.

5.6 Setting the Cartesian (Rectangular) Range in the XY Coordinate System of the Manipulator

The Cartesian (rectangular) range in the XY coordinate system of the Manipulator is specified by the limited Manipulator operation area and the XYLIM setting.

The limited Manipulator operation area is defined so that the end effector does not interfere with the rear side of the Manipulator. The XYLIM setting that you can determines the upper and lower limits of the X and Y coordinates.

The limited Manipulator operation area and the XYLIM setting apply only to the software. Therefore, these settings do not change the physical range. The maximum physical range is based on the position of the mechanical stops.

These settings are disabled during a joint jogging operation. Therefore, be careful not to allow the end effector to collide with the Manipulator or peripheral equipment.

The method for changing the XYLIM setting varies with the software used.

Epson
RC+

Set the XYLIM setting in [Tools]-[Robot manager]-[XYZ Limits] panel.
You may also execute the XYLim command from the [Command Window].

6. Options

C4 series Manipulator has the following options.

- 6.1 Brake Release Unit
- 6.2 Camera Plate Unit
- 6.3 PS Compatible Plate (Tool Adapter)
- 6.4 Base Side Angled Fittings
- 6.5 Base Side Fittings
- 6.6 PS Compatible Plate (Base Adapter)
- 6.7 Adjustable Mechanical Stop (Joint #2: Only C4-A901**)

6.1 Brake Release Unit

With the electromagnetic brake is ON (such as in Emergency Stop status), all arms don't move.

You can move the Arms by hand using the brake release unit while the Controller power is OFF or right after unpacking.

 WARNING	<ul style="list-style-type: none"> ■ When connecting / replacing the brake release unit or the external short connector, turn OFF the power to the Controller and the brake release unit. Inserting and removing the connector while the power is ON may result in electrical shock.
--	---

 CAUTION	<ul style="list-style-type: none"> ■ Normally, release the brake of joints one by one. Take extra care if you need to release the brakes of two or more joints simultaneously. Releasing the brakes of two or more joints simultaneously may cause hands and fingers to be caught and/or equipment damage to or malfunction of the Manipulator as the arms of the Manipulator may move in unexpected directions. ■ After releasing the brake, the arm may fall by its own weight or move to the unexpected direction. Make sure to prepare a countermeasure to prevent the arm from falling and check the operation environment is safe.
--	--

Width	180 mm
Depth	150 mm
Height	87 mm
Weight (Cables are not included.)	1.7 kg
Cable to the Manipulator	2 m

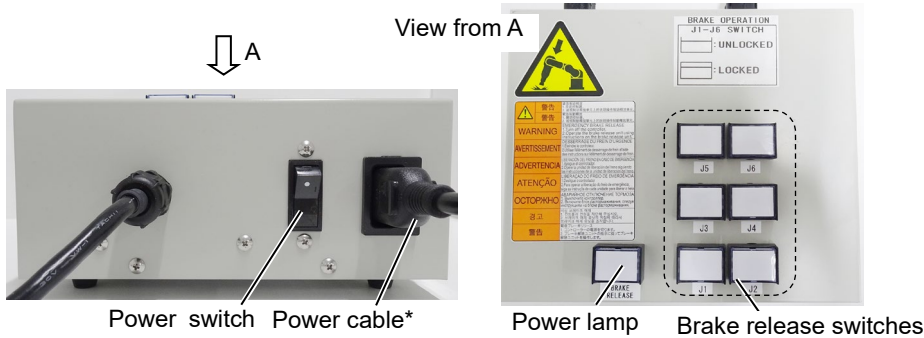

* Item you should provide

Power Cable

You must provide a power cable.

The power cable is required to meet the specifications below.

Item	Specification
(1) Plug	Comply with local safety regulation - Class I (2P+PE), AC250V, 6A or 10A Ex.: CEE Pub.7 Certified, CCC Certified, KC Certified, BS1363 Certified, PSB Certified, BIS Certified, SABS Certified - Class I (2P+PE), AC125V, 7A or 12A or, 15A etc. Ex.: UL Certified, PSE Certified, BSMI Certified
(2) Flexible cable	Comply with IEC/EN standards or local safety regulation Ex.: IEC 60227-1 General requirements IEC 60227-5 Polyvinyl chloride insulated cables of rated voltages up to and including 450/750 V - Part 5: Flexible cables (cords) EN 50525-1 General requirements EN 50525-2-11 Electric cables - Low voltage energy cables of rated voltages up to and including 450/750 V (Uo/U) - Part 2-11: Cables for general applications - Flexible cables with thermoplastic PVC insulation
(3) Appliance coupler	Comply with IEC/EN standards or local Safety regulation - IEC / EN 60320-1: Appliance couplers for household and similar general purposes - Part 1: General requirements - Standard Sheet C13: AC250V / 10A

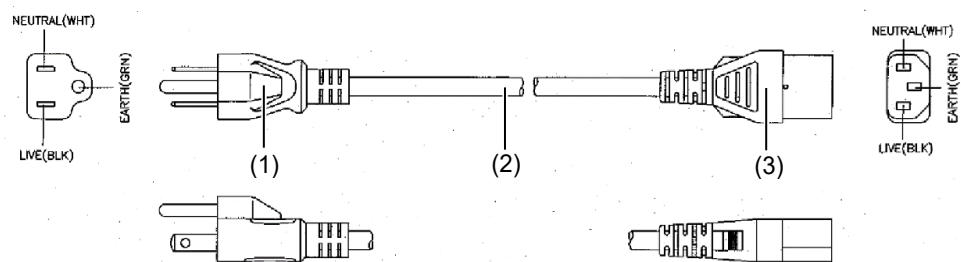

For Japan

Item	Specification
Plug	PSE Certified Class I (2P+PE), AC125V, 7A or higher
Code	PSE Certified 0.75mm ² or larger
Connector	PSE Certified IEC 60320-1 Standard Sheet C13: AC125V/10A or higher

Precautions for use

 CAUTION	<ul style="list-style-type: none"> ■ After the brake release unit is disconnected, be sure to connect the external short connector. Otherwise, you cannot release the brakes. If the Manipulator is operated without connecting the brake release unit and the external short connector, the brakes cannot be released and it may cause damage on them. After using the brake release unit, be sure to connect the external short connector to the Manipulator, or check connection of the connector for the brake release unit. ■ Keep the external short connector. Otherwise you cannot release the brakes. ■ If you turn ON the brake release unit while the brake release switch is being pressed, an unintended arm may move downward. Before turning ON the brake release unit, make sure that the brake release switch is not pressed. ■ If you turn ON the brake release unit without the connector, it may lead to the short for the male pin used in the connector. Before turning ON the brake release unit, make sure that the connector is connected.
--	---

Mount the brake release unit

- (1) Turn OFF the Controller.
- (2) Remove the external short connector.

NOTE  If the external short connector is the type which is shown below, remove it with a tool.

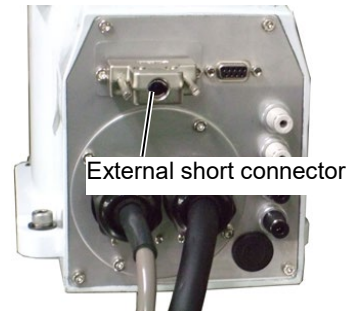

- (3) Connect the brake release unit to the connector of the connection cable.

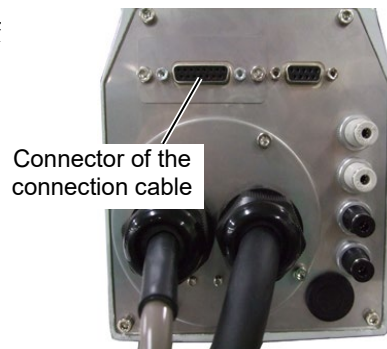

Remove the brake release unit

- (1) Turn OFF the brake release unit.
- (2) Remove the power cable of the brake release unit.
- (3) Disconnect the brake release unit from the connector of the connection cable.
- (4) Connect the external short connector to the connector of the connection cable.

NOTE  If the external short connector is the type which is shown below, connect it with a tool.



How to use the brake release unit



CAUTION

- After releasing the brake, the arm may fall by its own weight or move to the unexpected direction. Make sure to prepare a countermeasure to prevent the arm from falling and check the operation environment is safe.
 - If the arm you released its brake moves awkwardly or faster than usual, stop the operation promptly and contact the supplier of your region. The brake release unit may be broken.
- If you keep operating the Manipulator, it may lead to the breakdown of the Manipulator or you may get your hand or fingers caught.

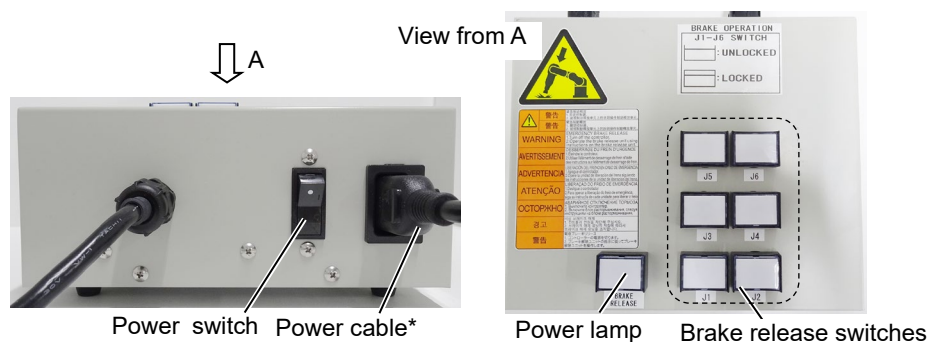

* Item you should provide

- (1) Refer to “Mount the brake release unit” above to connect the brake release unit to the connector of the connection cable.
 - (2) Plug the power cable into the brake release unit.
 - (3) Plug the power cable into the power supply plug.
 - (4) Turn ON the brake release unit.
- When the brake release unit is enabled, the power lamp lights up.

- (5) Press the switch of the arm (J1 to J6) you want to move and then move the arm. Press the switch again. The brake will be released. The brake will be enabled by pressing the switch once again.

NOTE  Move the arm the brake is released by two persons or more (one presses the switch and one moves the arm). The arm can be very heavy and needs the significant force to move.

6.2 Camera Plate Unit

To mount a camera to the C4 series Manipulator, you need to mount the camera plate unit first.

Appearance of arm end with camera

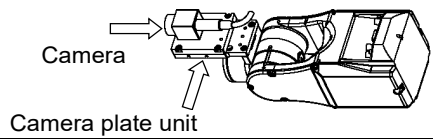

Parts included		unit
A	Camera adapter plate	1
B	Camera mid plate	1
C	Camera base plate	1
D	Hexagon socket head screws M4×12	6
E	Hexagon socket head screws M4×20	2
F	Plain washer for M4 (small washer)	2

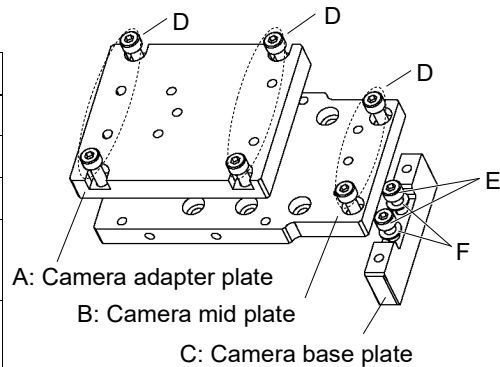

To mount the camera plate unit

NOTE  For details of tightening the hexagon socket head screws, refer to “Regular Inspection 1.4 Tightening Hexagon Socket Head Bolts”

- (1) Mount the camera base plate to the Manipulator.
2-M4 × 20 + Plain washer for M4 (small washer)
- (2) Mount the camera mid plate to the base plate.
2-M4 × 12

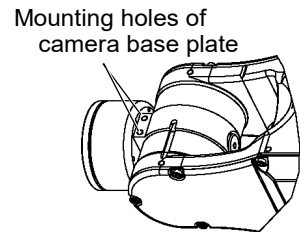

NOTE  The motion range and dimension of the Manipulator with the camera installed may vary depending on the mounting hole of camera mid plate. The details are described in the table below.

- (3) Mount the camera to the camera adapter plate.

NOTE  According to the camera, the available mounting hole of adapter plate will be different. The details are described below.

- (4) Mount the camera adapter plate and camera to the camera mid plate.
4-M4 × 12
- (5) Secure the cables at the position where they do not interfere with the Manipulator motion.

NOTE  When securing the cables, check if the cables bend radius is big enough and the cables are not rubbing against each other while the Manipulator moves. Otherwise, the cables will be disconnected.

Dimension of the camera plate unit

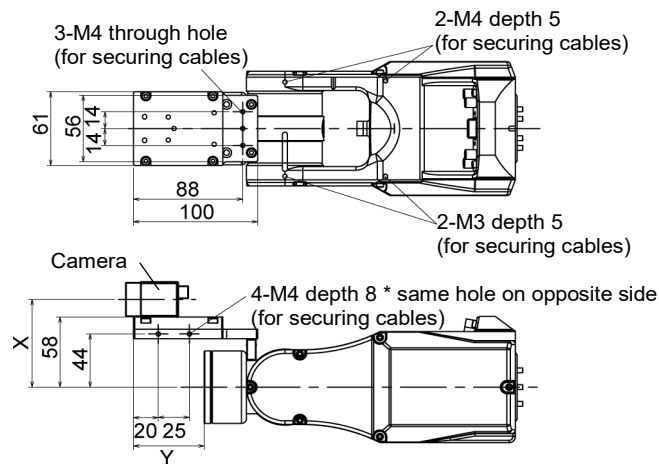

Dimensions X and Y will change depending on the position of camera mid plate and camera size. Refer to the table below for the values.

Camera mid plate

The camera mid plate uses the mounting holes A to D.

By using the different mounting holes, it can be mounted to the camera base plate in the different four positions.

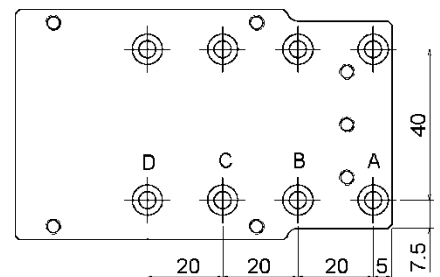

Camera adapter plate

Each camera uses the different mounting holes.

USB camera : J (2 holes)

GigE camera : E (3 holes)

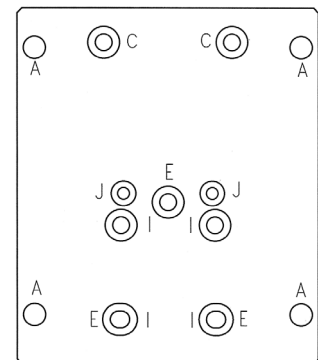

Mounting example

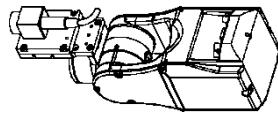

Using the mounting hole A

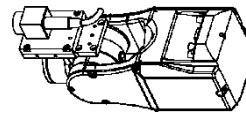

Using the mounting hole C

E.g.) Camera: XC-ES30

Camera and Joint #5 motion range (reference values)

The Joint #5 motion range varies depending on the mounting position of camera mid plate and the camera you are using.

The table below shows the motion range (reference values) based on the available cameras for this option and the mounting positions of the camera mid plate. The values in the table may vary depending on how to secure the cables.

By changing the Y position, you can extend the distance from the end effector mounting surface to the camera. Also, you can attach the larger end effector. However, be careful about the Joint #5 motion range that will be limited in this case.

(° = deg.)

	A	B	C	D	X
USB camera, GigE camera	-135° ~ +60°	-135° ~ +50°	-135° ~ +35°	-135° ~ +25°	72.5 mm

	A	B	C	D
Y	57 mm	37 mm	17 mm	7 mm

Direction of the Joint #5 motion

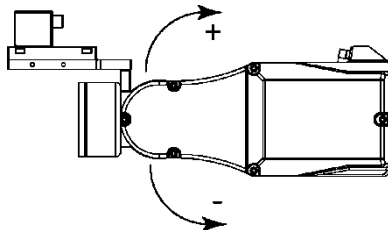

6.3 PS Compatible Plate (Tool Adapter)

Using the PS compatible plate, you can mount the end effector used in the PS series to the C4 series. Also you can mount the end effectors with flange which is conformed to ISO9409-1.

Parts included		Qty.
A	PS compatible plate 1	1
B	PS compatible plate 2	1
C	Hexagon socket head screw M4×6	4
D	Hexagon socket head screw M3×8	8
E	Dowel pin (M3 hole on one side)	2

Dimensions of PS compatible plate

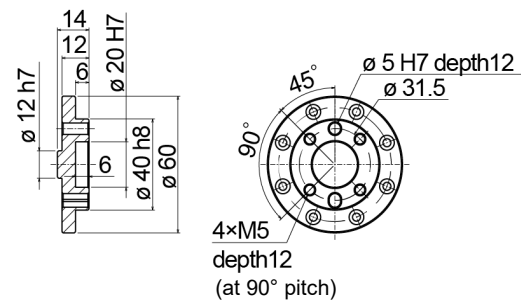

C: Hexagon socket head screw
4-M4×6

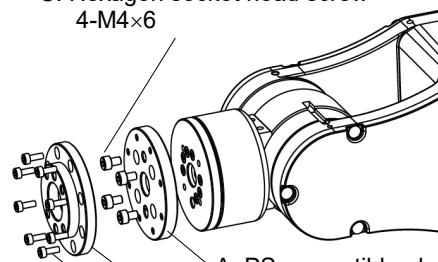

A: PS compatible plate 1

B: PS compatible plate 2

D: Hexagon socket head screw
8-M3×8

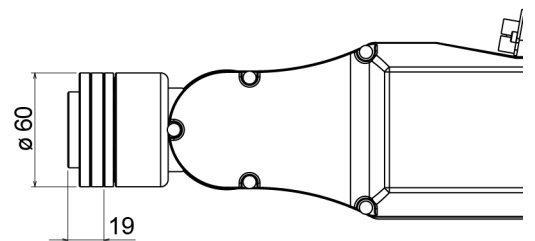

* Each dimension and tolerance complies with ISO9409-1-31.5-4-M5.

Installation

NOTE  For details of tightening the hexagon socket head screws, refer to “Regular Inspection 1.4 Tightening Hexagon Socket Head Bolts”

- (1) Align the hole on the arm end flange (ø12H7) to the projection on the PS compatible plate 1 (ø12h7).
- (2) Insert the dowel pin from the PS compatible plate 1 side and position the arm and PS compatible plate 1.
- (3) Secure the PS compatible plate 1 with 4 hexagon socket head screws.

4-M4×6

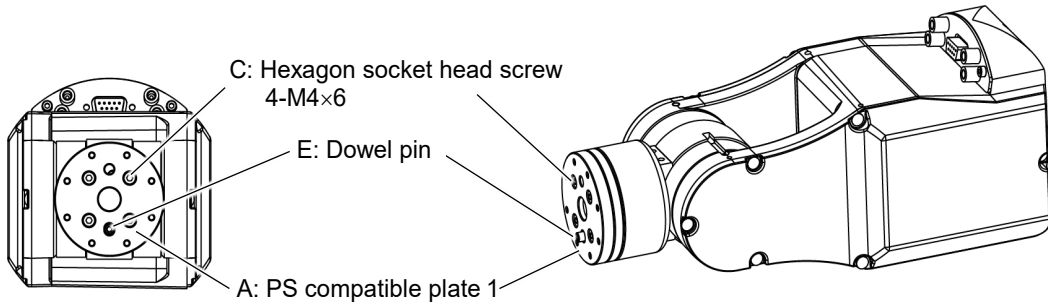

NOTE  If you move the Manipulator with the dowel pin inserted, the dowel pin will fall out. After fixing the PS compatible plate 1, remove the dowel pin.

- (4) Align the hole on the PS compatible plate 1 (ø12H7) to the projection on the PS compatible plate 2 (ø12h7).
- (5) Insert the dowel pin from the PS compatible plate 2 side and position the PS compatible plate 1 and 2.
- (6) Secure the PS compatible plate 2 with 8 hexagon socket head screws.

8-M3×8

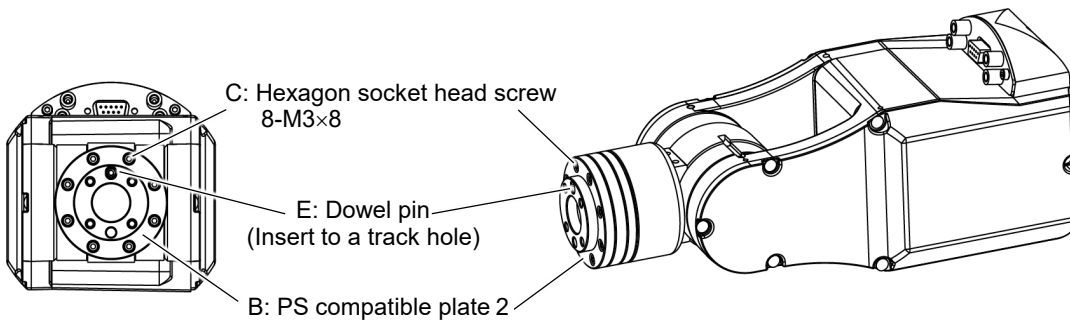

NOTE  If you move the Manipulator with the dowel pin inserted, the dowel pin will fall out. After fixing the PS compatible plate 2, remove the dowel pin.

6.4 Base Side Angled Fittings

By using the base side angled fittings to the C4 series Manipulator base, you can mount the Manipulator in skewed position. The motion range expands with this mounting type compared to the normal ceiling mounting.

Mounting image using the base side angled fittings

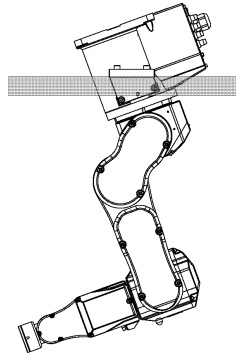

For details of the mounting and precautions, refer to “3. Environment and Installation”.

Parts included		Qty.
A	Base side angled plate (Left side)	1
B	Base side angled plate (Right side)	1
C	Base side plate (for Skewed mounting type)	2
D	Pin	6
E	Hexagon socket head screw M8 × 25	4
F	Hexagon socket head screw M8 × 30	4

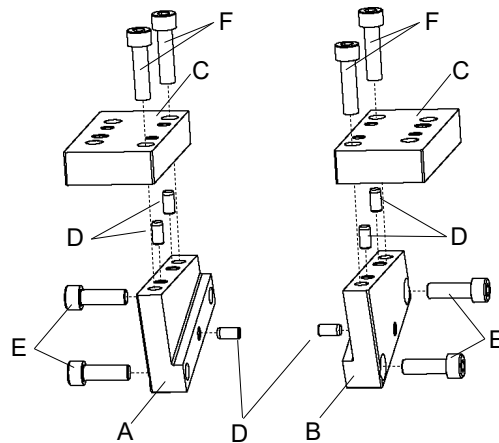

To mount the base side angled fittings

NOTE For details of tightening the hexagon socket head screws, refer to “Regular Inspection 1.4 Tightening Hexagon Socket Head Bolts”

- (1) Drive pins to the base side plate (for Skewed mounting type).
Protruding part of pins is approx. 2 to 5 mm.

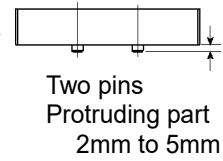

- (2) Drive pins to the base side angled plate (left & right sides).
Protruding part of pins is approx. 2 to 5 mm.

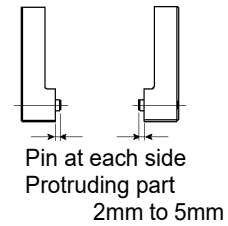

- (3) Create a base side angled fittings.
Fit the pins of the plate for Skewed mounting type in the step (1) with the holes on the plate in the step (2) and secure with the screws.

Hexagon socket head screw M8 × 30

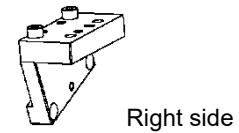

- (4) Mount the base side angled fittings to the both sides of Manipulator base.
Fit the pins drove in the step (2) with the holes on the base. Secure the fittings by pressing it to the indicated direction in the figure below.

Left & Right side Hexagon socket heat screw 2- M8 × 25

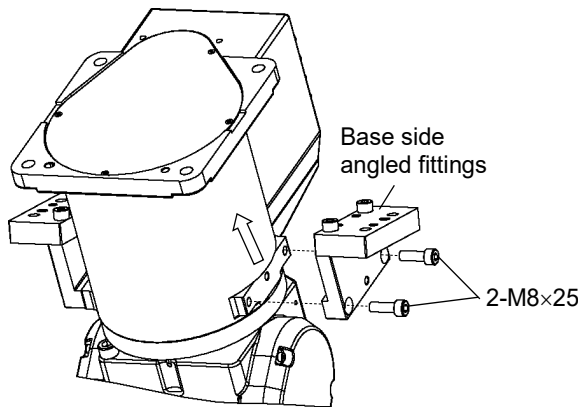

NOTE The shape of the base side angled fittings is asymmetry. Be sure to mount the fittings in correct direction. Otherwise, the motion range of Arm #2 is limited in the backside.

NOTE The recommended base plate thickness is between 30 mm and 40 mm. If the thickness is more than 40 mm, the Manipulator may contact the base plate when the Arm #1 rotates depending on the center cut dimension in the base plate.

The base plate securing the Manipulator should be prepared by users. The torque value and reaction force generated in the Manipulator motions are described in “3.4 Installation”.

6.5 Base Side Fittings

Using the base side fittings to the C4 Manipulator base, you can mount the Manipulator in the place where limits the mounting height or use the open room for the base.

Mounting image using the base side fittings

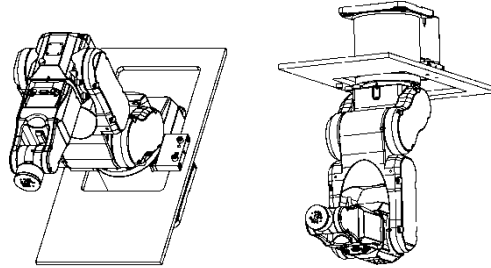

For the information on how to mount and precautions, refer to “3. Environment and Installation”.

Parts included		Qty.
A	Base side plate	2
B	Pin	2
C	Hexagon socket head screw M8 × 60	4

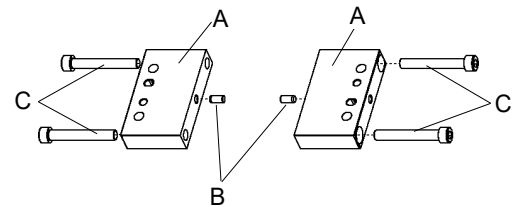

To mount the base side plate

NOTE

For details of tightening the hexagon socket head screws, refer to “Regular Inspection 1.4 Tightening Hexagon Socket Head Bolts”

- (1) Drive the pins to the base side plate.

Protruding part of pins is approx. 2 to 5 mm.

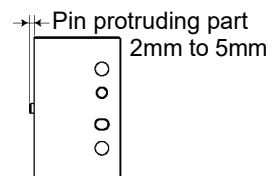

- (2) Mount the base side plate with the pins driven to the both sides of the base.

Fit the pins with the holes and secure the base side plate by pressing it from above to the base fixing part.

(With the steps above, the both surfaces of base side fittings can be stable.)

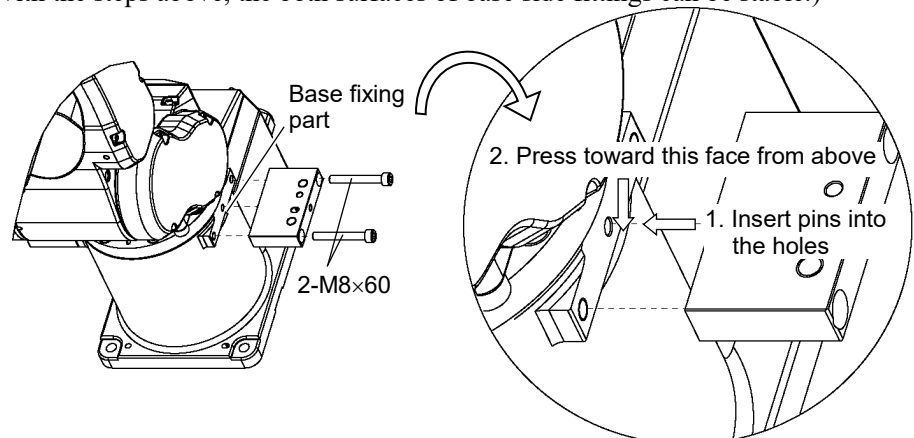

Dimension of the Manipulator with the base side fittings

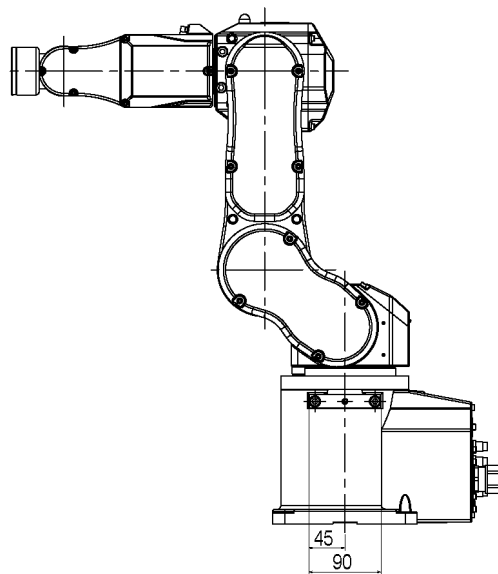
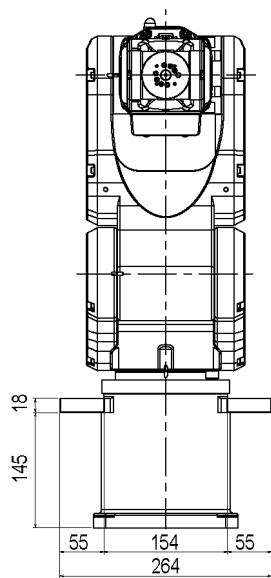
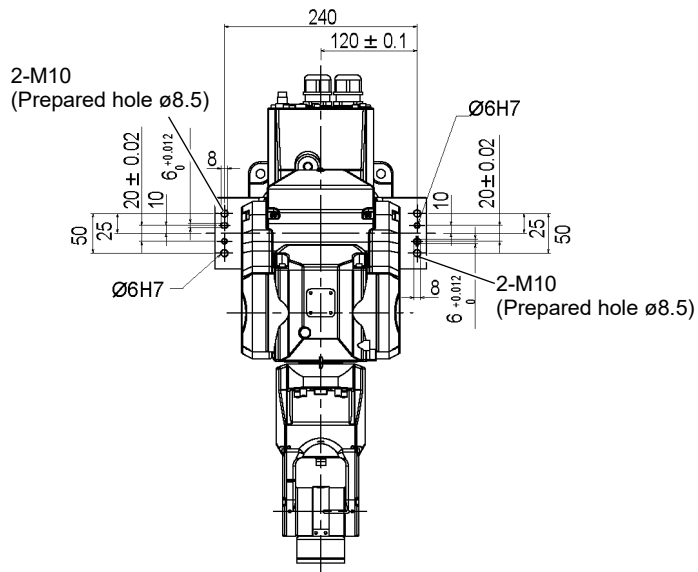

Installation example

Screws

	Size	Recommended length
A	M8	30 mm or more
B	M10	15 mm + Base Plate or more

NOTE  The base side plate has a M10 screw hole. You can secure the plate with a M10 screw or a M8 screw by using a prepared screw hole of $\varnothing 8.5$ to make a M8 screw hole on the mounting surface.

NOTE  A: Securing from above
To secure from above, use the screw A in the table above.

When you install the Manipulator for practical use, you need to insert the screws in the right/left side from the same direction (above or below).

Table Top mounting

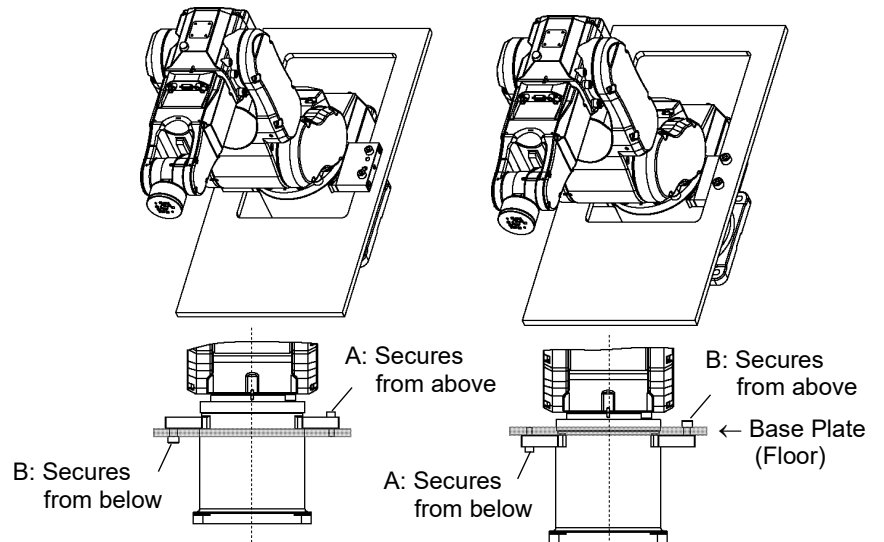

Ceiling mounting

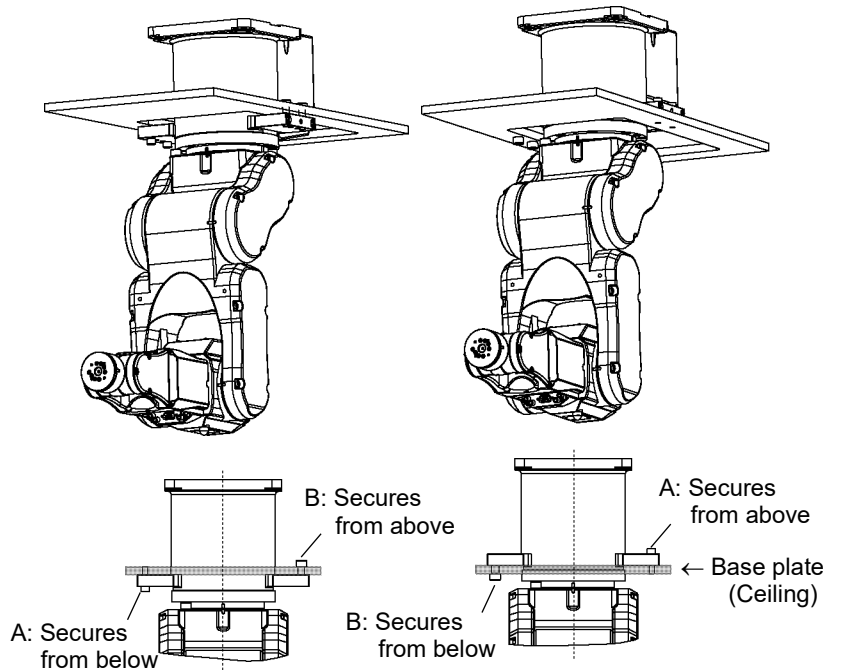

6.6 PS Compatible Plate (Base Adapter)

PS compatible plate is used to use Manipulator fixing taps for PS series to the C4 series Manipulator.

Parts included	Qty.
A PS compatible plate	1
B Dowel pin (M4 hole on one side)	3
C Dowel pin (M6 hole on one side)	2
D M10×25 hexagon socket head cap bolt	8
E Plain washer	4
F Spring washer	8

Dimensions of PS compatible plate

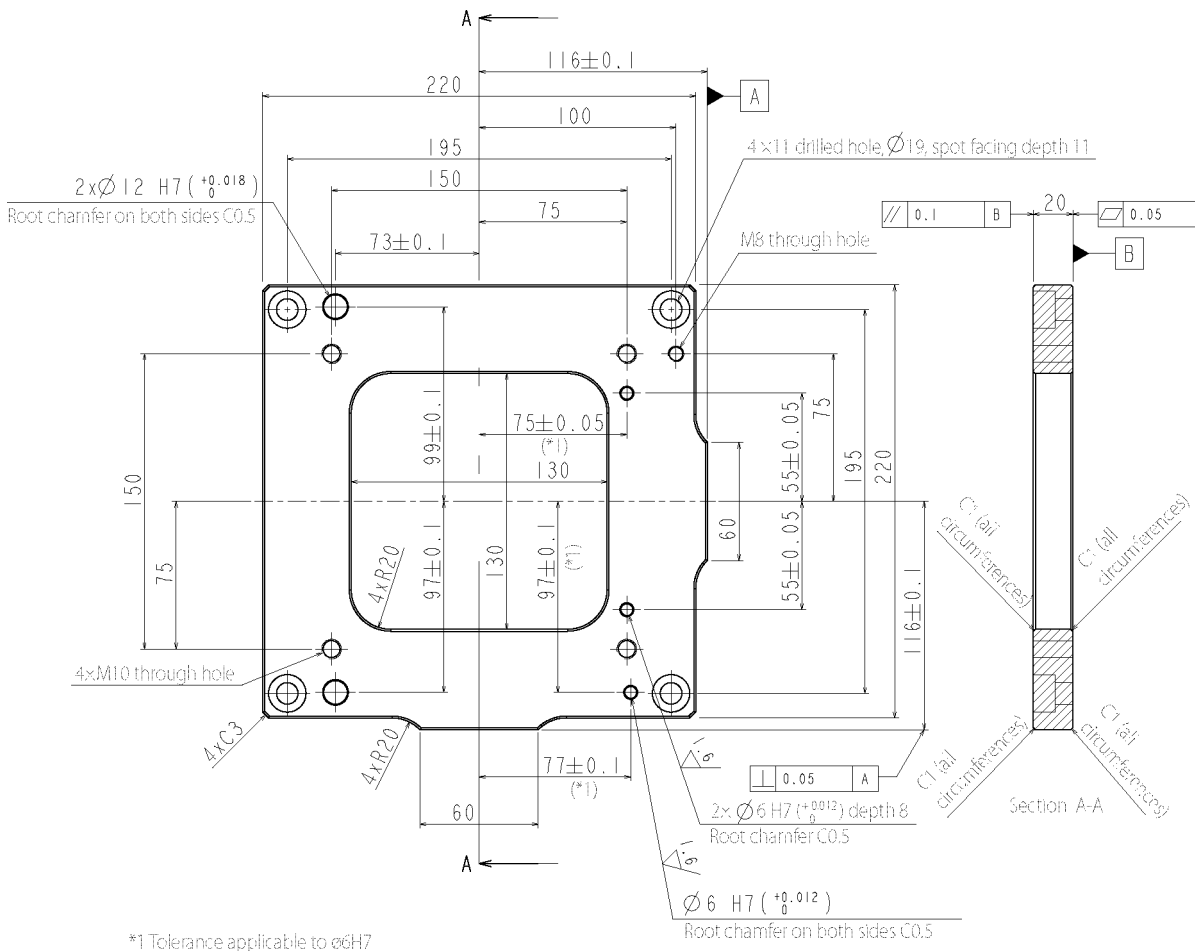

Installation



For details of tightening the hexagon socket head screws, refer to “*Regular Inspection 1.4 Tightening Hexagon Socket Head Bolts*”

- (1) Fix the mounting table and the PS compatible plate with hexagon socket head cap bolts and spring washers.
Use dowel pins as needed to adjust positions of the mounting table and the PS compatible plate.
- (2) Fix the C4 series Manipulator and the PS compatible plate.
Hexagon socket head cap bolts (4-M10×25) + spring washers + plain washers
Use dowel pins as needed to adjust positions of the Manipulator and the PS compatible plate.

6.7 Adjustable Mechanical Stop (Joint #2: only C4-A901**)

Adjustable mechanical stops physically limit the absolute area that the Manipulator can move.

Be sure to turn OFF the Controller in advance.

Use high corrosion-resistant stainless bolts or equivalent material.

Specify the pulse range again after changing the position of the mechanical stop.

For details on the pulse range setting, refer to “*5.1 Motion Range Setting by Pulse Range (for All Arms)*”.

Be sure to set the pulse range not to exceed the setting angles of the mechanical stop.

	Parts included	Qty.
A	Adjustable mechanical stop	1
B	M6×40 hexagon socket head cap bolt	2
C	Plain washer	2

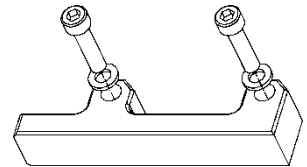

Installation

NOTE  For details of tightening the hexagon socket head screws, refer to “Regular Inspection 1.4 Tightening Hexagon Socket Head Bolts”

Installation

- (1) Remove the bolts fixing the Arm #2 spacer (2- M6×20).

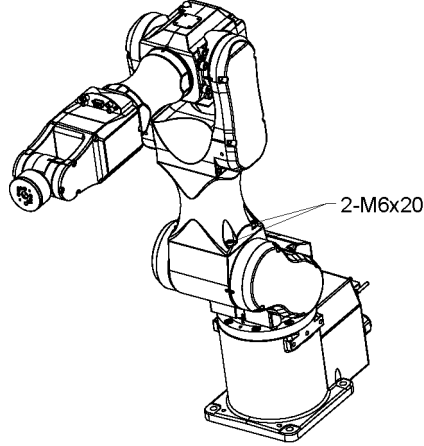

- (2) Fix the adjustable mechanical stop with the bolts (2-M6×40) and plain washers.
Direction of the adjustable mechanical stop depends on the angular limitation to be set.

Installation 1

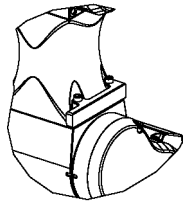

Installation 2

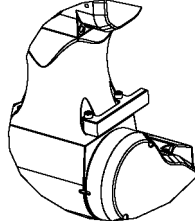

	Installation 1	Installation 2	-	-
Angle (°)	-153	+50	-160	+65
Pulse (pulse)	-4456448	+1456356	-7626008	+3098066
Adjustable mechanical stop	Applied	Applied	Not applied (standard)	Not applied (standard)

C8 Manipulator

This volume contains information for setup and operation of the Manipulators.
Please read this volume thoroughly before setting up and operating the Manipulators.

1. Safety



Unpacking and transportation of the Manipulators and robotic equipment shall be performed by personnel who has taken robot system training held by us and suppliers and should conform to all national and local codes.

Please read this manual and other related manuals before installing the robot system or before connecting cables.

Keep this manual handy for easy access at all times and reread it when you find anything unclear.

1.1 Conventions

Important safety considerations are indicated throughout the manual by the following symbols. Be sure to read the descriptions shown with each symbol.

 WARNING	This symbol indicates that a danger of possible serious injury or death exists if the associated instructions are not followed properly.
 WARNING	This symbol indicates that a danger of possible harm to people caused by electric shock exists if the associated instructions are not followed properly.
 CAUTION	This symbol indicates that a danger of possible harm to people or physical damage to equipment and facilities exists if the associated instructions are not followed properly.

1.2 Design and Installation Safety

This product is intended for transporting and assembling parts in a safely isolated area. Design and installation of robot system shall be performed by personnel who has taken robot system training held by us and suppliers.

To ensure safety, a safeguard must be installed for the robot system. For details on the safeguard, refer to the *Installation and Design Precautions* in the *Safety* chapter of the Epson RC+ User's Guide.



The following items are safety precautions for design personnel:

 <p>WARNING</p>	<ul style="list-style-type: none">■ Personnel who design and/or construct the robot system with this product must read “<i>Safety Manual</i>”. Designing and/or constructing the robot system without understanding the safety requirements is extremely hazardous, and may result in serious bodily injury and/or severe equipment damage to the robot system.■ The Manipulator and the Controller must be used within the environmental conditions described in their respective manuals. This product has been designed and manufactured strictly for use in a normal indoor environment. Using the product in an environment that exceeds the specified environmental conditions may not only shorten the life of the product but may also cause serious safety problems.■ The robot system must be used within the installation requirements described in the manuals. Using the robot system outside of the installation requirements may not only shorten the life of the product but also cause serious safety problems.■ When designing or installing a robot system, wear at least the following protective gear. Working without protective gear may cause serious safety problems.<ul style="list-style-type: none">Work clothes suitable for workHelmetSafety shoes
---	---

Further precautions for installation are described in “3. *Environment and Installation*”. Please read this chapter carefully to understand safe installation procedures before installing the robots and robotic equipment.

1.3 Operation Safety

The following items are safety precautions for qualified Operator personnel:

 WARNING	<ul style="list-style-type: none"> ■ Please carefully read “<i>Safety Manua</i> ”. Operating the robot system without understanding the safety precautions is extremely hazardous and may result in serious bodily injury and/or severe equipment damage to the robot system. ■ Do not enter the operating area of the Manipulator while the power to the robot system is turned ON. Entering the operating area with the power ON is extremely hazardous and may cause serious safety problems as the Manipulator may move even if it seems to be stopped. ■ Before operating the robot system, make sure that no one is inside the safeguarded area. The robot system can be operated in the mode for teaching even when someone is inside the safeguarded area. The motion of the Manipulator is always in restricted status (low speeds and low power) to secure the safety of an operator. However, operating the robot system while someone is inside the safeguarded area is extremely hazardous and may result in serious safety problems in case that the Manipulator moves unexpectedly. ■ Immediately press the Emergency Stop switch whenever the Manipulator moves abnormally during operation. Continuing the operation while the Manipulator moves abnormally is extremely hazardous and may result in serious bodily injury and/or severe equipment change to the robot system.
 WARNING	<ul style="list-style-type: none"> ■ Be sure to connect the AC power cable to a power receptacle. DO NOT connect it directly to a factory power source. To shut off power to the robot system, disconnect the power plug from the power source. Performing any work while connecting the AC power cable to a factory power source is extremely hazardous and may result in electric shock and/or malfunction of the robot system. ■ Before performing any replacement procedure, turn OFF the Controller and related equipment, and then disconnect the power plug from the power source. Performing any replacement procedure with the power ON is extremely hazardous and may result in electric shock and/or malfunction of the robot system. ■ Do not connect or disconnect the motor connectors while the power to the robot system is turned ON. Connecting or disconnecting the motor connectors with the power ON is extremely hazardous and may result in serious bodily injury as the Manipulator may move abnormally, and also may result in electric shock and/or malfunction of the robot system.

 CAUTION	<ul style="list-style-type: none"> ■ Whenever possible, only one person should operate the robot system. If it is necessary to operate the robot system with more than one person, ensure that all people involved communicate with each other as to what they are doing and take all necessary safety precautions. ■ If the joints are operated repeatedly with the operating angle less than 5 degrees, they may get damaged early because the bearings are likely to cause oil film shortage in such situation. To prevent early breakdown, move each joint larger than 30 degrees for about once an hour. ■ Oscillation (resonance) may occur continuously in low speed Manipulator motion (Speed: approx. 5 to 20%) depending on combination of Arm orientation and end effector load. Oscillation arises from natural oscillation frequency of the Arm and can be controlled by following measures. <ul style="list-style-type: none"> Changing Manipulator speed Changing the teach points Changing the end effector load
---	---

1.4 Emergency Stop

If the Manipulator moves abnormally during operation, immediately press the Emergency Stop switch. Pressing the Emergency Stop switch immediately changes the Manipulator to deceleration motion and stops it at the maximum deceleration speed.

Avoid pressing the Emergency Stop switch unnecessarily while the Manipulator is running normally.

- The Manipulator may hit the peripheral equipment.
When you press the Emergency Stop switch, the operating trajectory until the robot system stops is different from that in normal operation.
- The life of the brakes will be shortened.
The brakes are locked and the brake friction plate is worn.
Normal brake life cycle: About 2 years (when the brakes are used 100 times/day)
However, the rough normal relay life is approximately 20,000 times. If you press the emergency stop switch unnecessarily, the life of the relay will be shortened.
- Impact is applied on the reduction gear unit, and it may result in the short life of the reduction gear unit.

To place the robot system in emergency mode during normal operation, press the Emergency Stop switch while the Manipulator is not moving.

Refer to the Robot Controller manual for instructions on how to wire the Emergency Stop switch circuit.

Do not turn OFF the Controller while the Manipulator is operating.

If you attempt to stop the Manipulator in emergency situations, make sure to stop the Manipulator using the E-STOP of the Controller.

If the Manipulator is stopped by turning OFF the Controller while it is operating, the following problems may occur.

Reduction of the life and damage of the reduction gear unit

Position gap at the joints

In addition, if the Controller was forced to be turned OFF by blackouts and the like while the Manipulator is operating, make sure to check the following points after power restoration.

Whether or not the reduction gear is damaged

Whether or not the joints are in their proper positions

If there is a position gap, perform calibration by referring to “*C series Maintenance Manual 16. Calibration*”.

Before using the Emergency Stop switch, be aware of the followings.

- The Emergency Stop (E-STOP) switch should be used to stop the Manipulator only in case of emergencies.
- To stop the Manipulator operating the program except in emergency, use Pause (halt) or STOP (program stop) commands.
Pause and STOP commands do not turn OFF the motors. Therefore, the brake does not function.
- For the safeguard, do not use the E-STOP circuit.

To check brake problems, refer to “*Regular Inspection 1. Regular Inspection for C8 Manipulator*”.

NOTE



Test pulse cannot be used with the emergency stop input of this model.

Stopping distance in emergency

The Manipulator in operation cannot stop immediately after the Emergency Stop switch is pressed. In addition, stopping time and stopping distance vary by following factors:

Hand weight	WEIGHT Setting	ACCEL Setting
Workpiece weight	SPEED Setting	Posture etc.

For stopping time and stopping distance of the Manipulator, refer to “*Appendix B: Stopping Time and Stopping Distance in Emergency*”.

1.5 Safeguard

To ensure safe operation, install a safety system using safety doors, light curtains, safety floor mats, etc.

When a closed safeguard is open during robot motion, the safeguard interlock function operates. The robot stops immediately and enters into pause state. Then, all robot motors are turned OFF. The descriptions below explain how the safeguard input works.

Safeguard open : The robot stops immediately, motors are turned OFF, and further operation is impossible until either the safeguard is closed or TEACH or TEST mode is turned ON and the enable circuit is engaged.

Safeguard closed : The robot can automatically operate in unrestricted (high power) state.

Do not open the safeguard unnecessarily while motor is ON. Frequent safeguard inputs affect the life of the relay.

Rough normal relay life: Approximately 20,000 times

For the safeguard, do not use the E-STOP circuit.

For details of wiring instructions, refer to the following manuals.

RC90 series Manual 9. *EMERGENCY*

RC700 series Manual 11. *EMERGENCY*

For details of the safeguard, refer to the following manuals as well.

RC90 series Manual 2.7.1 *Connection to EMERGENCY Connector*

RC700 series Manual 2.7.1 *Connection to EMERGENCY Connector*



Test pulse cannot be used with the safeguard input of this model.

 WARNING	<ul style="list-style-type: none"> ■ The EMERGENCY connector on the controller has a safeguard input circuit to connect the safety device interlock switch. To protect operators working near the robot, be sure to connect the interlock switch and make sure that it works properly. ■ The time to stop the robot and the stopping distance by the safeguard interlock function will change depending on the conditions of use. Be sure to confirm that safety is ensured according to the installation environment of the robot.
---	---

Stopping distance when the safeguard is opened

The Manipulator in operation cannot stop immediately after the safeguard is opened. In addition, stopping time and stopping distance vary by following factors:

Hand weight	WEIGHT Setting	ACCEL Setting
Workpiece weight	SPEED Setting	Posture etc.

For stopping time and stopping distance of the Manipulator, refer to “Appendix C: Stopping Time and Stopping Distance When the Safeguard is Opened”.

1.6 How to Move Arms with the Electromagnetic Brake

There are two methods to release the electromagnetic brake. Follow either method to release the electromagnetic brake and move the arms manually.

1.6.1 Moving the arm using the brake release unit

Follow the method when you just unpack the delivered boxes or when the Controller does not start up yet.

1.6.2 Moving the arm using the software

Follow the method when you can use the software.

While the electromagnetic brake is ON (such as in emergency mode), you cannot move any arm by pushing manually.

Arm Motion

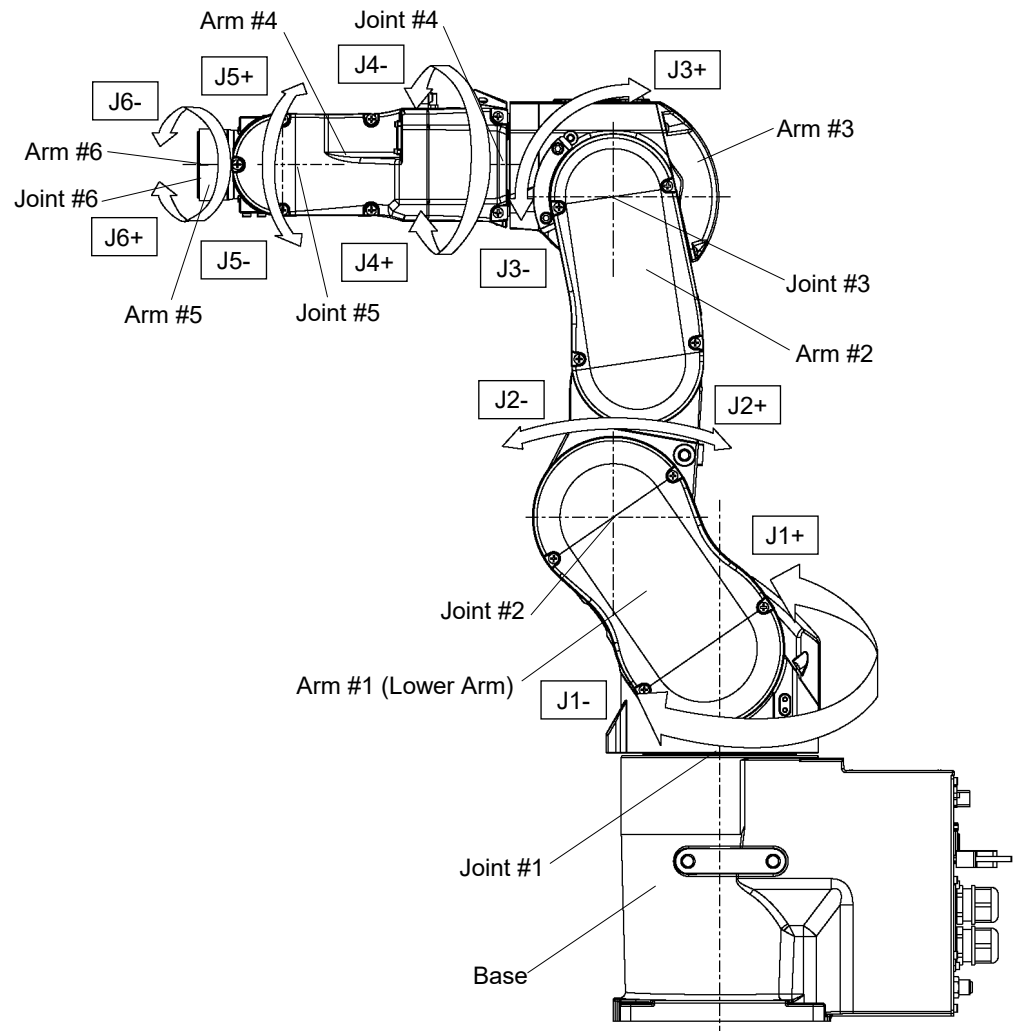

(Figure: C8-A701* (C8))

1.6.1 Moving the Arm using the brake release unit

The C8 series has the Brake Release Unit as an option.
For details, refer to “6 Options”.

1.6.2 Moving the Arm using the software

 CAUTION	<ul style="list-style-type: none"> ■ Normally, release the brake of joints one by one. Take extra care if you need to release the brakes of two or more joints simultaneously. Releasing the brakes of two or more joints simultaneously may cause hands and fingers to be caught and/or equipment damage to or malfunction of the Manipulator as the arms of the Manipulator may move in unexpected directions. ■ After releasing the brake, the arm may fall by its own weight or move to the unexpected direction. Make sure to prepare a countermeasure to prevent the arm from falling and check the operation environment is safe. ■ Before releasing the brake, be sure to keep the Emergency Stop switch handy so that you can immediately press the Emergency Stop switch. Otherwise, you cannot immediately stop the arm falling due to an erroneous operation. The arm falling may cause equipment damage to and/or malfunction of the Manipulator.
--	---

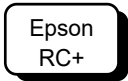

After releasing the Emergency Stop switch, execute the following command in [Command Window].

```
>Reset
>Brake Off, [the number (from 1 to 6) corresponding to the arm whose brake will be turned off]
```

Execute the following command to turn on the brake again.

```
>Brake On, [The number (from 1 to 6) corresponding to the arm whose brake will be turned on]
```

1.7 Precaution for Operation in Low Power Status

In the low power status, the Manipulator operates at low speed and low torque. However, comparatively high torque as shown in the table below may be generated to support the Manipulator’s own weight.

Carefully operate the Manipulator since it may get your hands or fingers caught during operation. The Manipulator may also collide with peripheral equipment and cause equipment damage to or malfunction of the Manipulator.

Maximum Joint Torque in Low Power Status [Unit: N·m]

Joint		#1	#2	#3	#4	#5	#6
Joint Torque	C8-A701*** (C8)	144.9	245.1	114.2	35.0	40.0	20.5
	C8-A901*** (C8L)	149.5	270.9	129.3			
	C8-A1401*** (C8XL)	299.9	487.6	248.9			

 CAUTION	<ul style="list-style-type: none"> ■ Carefully operate the Manipulator in the low power status. A comparatively high joint torque may be generated. It may cause your hands and fingers caught and/or cause equipment damage to or malfunction of the Manipulator as it may collide with peripheral equipment.
--	---



1.8 Warning Labels



The Manipulator has the following warning labels.

The warning labels are attached around the locations where specific dangers exist.

Be sure to comply with descriptions and warnings on the labels to operate and maintain the Manipulator safely.

Do not tear, damage, or remove the warning labels. Use meticulous care when handling those parts or units to which the following warning labels are attached as well as the nearby areas.

Location	Warning Label	NOTE
A	 <p>警告 WARNING 警告 AVERTISSEMENT 警告 ADVERTENCIA 경고 ATENÇÃO ОСТОПЖHO</p> <p>TIP-OVER HAZARD RISQUE DE BASCULEMENT PELIGRO DE VUELO PERIGO DE QUEDA ОПАСНОСТЬ ОПРОКИДЫВАНИЯ</p> <p>当心倒下 当心倒下 転倒の危険 当心倒下</p> <p>ОПАСНОСТЬ ОПРОКИДЫВАНИЯ</p> <p>警告 警告 警告 警告 警告 警告 警告 警告 警告 警告</p> <p>在卸下底座安裝螺柱之前，請採取措施防止機械手掉落。 在卸下底座安裝螺柱之前，請採取措施防止機械手掉落。 Take measures to prevent the manipulator from falling and dropping before removing base mounting bolts. Prendre les mesures nécessaires pour empêcher le manipulateur de tomber avant de démonter les vis de fixation de base. Tome medidas para evitar que el manipulador se caiga antes de retirar los pernos de montaje de la base. Tome medidas para evitar que o manipulador caia antes de remover os parafusos de montagem da base. Перед снятием болтов крепления основания примите меры для предотвращения падения и падений манипулятора. 메이슨 작업을 할 때까지 작업 영역이 낙하하지 않도록 조치를 취하십시오. ベース取付ボルトを外す前に、マニピュレータの落下防止対策を行ってください。</p>	<p>To avoid getting hands or fingers caught, fold the Arm and fix it with a belt or a similar tool before removing the base mounting screws.</p>
B	 <p>警告 WARNING 警告 AVERTISSEMENT 警告 ADVERTENCIA 경고 ATENÇÃO ОСТОПЖHO</p> <p>当心碰撞 当心碰撞 衝突の危険 当心碰撞</p> <p>ОПАСНОСТЬ СТОЛКНОВЕНИЯ</p> <p>警告 警告 警告 警告 警告 警告 警告 警告 警告 警告</p> <p>移动时，机械臂可能会导致死亡或重伤。 移动时，机械臂可能会导致死亡或重伤。 When moving, robot arm can cause death or serious injury. Do not enter work envelope. En se déplaçant, le bras du robot peut provoquer des blessures graves ou mortelles. Ne pas pénétrer dans l'enveloppe de travail. Cuando se mueve, el brazo del robot puede causar la muerte o lesiones graves. No entre en el sobre de trabajo. Ao se mover, o braço do robô pode causar morte ou ferimentos graves. Não entre na área de trabalho. При движении рука робота может стать причиной смерти или серьезной травмы. Не входите в рабочий конвент. 移動時、機械臂が人命または重傷の原因となります。作業中は、絶対に動作エリアに入らないでください。アームに衝突する可能性があります。</p>	<p>Do not enter the work space when the Manipulator is operating. It is extremely hazardous since the Arm may collide and cause serious safety problems.</p>
C	 <p>警告 WARNING 警告 AVERTISSEMENT 警告 ADVERTENCIA 경고 ATENÇÃO ОСТОПЖHO</p> <p>当心触电 当心触电 感電の危険 当心触电</p> <p>ОПАСНОСТЬ ПОРЯЖЕНИЯ ЭЛЕКТРИЧЕСКИМ ТОКОМ</p> <p>警告 警告 警告 警告 警告 警告 警告 警告 警告 警告</p> <p>当心高温表面 当心高温表面 熱い表面 高温表面</p> <p>警告 警告 警告 警告 警告 警告 警告 警告 警告 警告</p> <p>HOT SURFACE SURFACE CHAUDE SUPERFICIE CALIENTE SUPERFICIE QUENTE ГОРЯЧАЯ ПОВЕРХНОСТЬ</p>	<p>Do not touch the current-carrying parts inside the Manipulator while the power is ON. It may cause electrical shock.</p>

Location	Warning Label	NOTE
D	 <p>警告 WARNING 警告 AVERTISSEMENT 警告 ADVERTENCIA 警告 ATENÇÃO 警告 ОСТОПЖНО</p> <p>当心夹手 CRUSH HAZARD 当心夹手 RISQUE D'ÉCRASEMENT 挟み込みの危険 PELIGRO DE APLASTAMIENTO 손을 끼움 PERIGO DE ESMAGAMENTO ОПАСНОСТЬ ПАЗРАБОТКИ</p> <p>请勿将手放在活动部件上。 請勿將手放在移動部件上。 Do not put your hand on moving parts. Ne pas placer les mains sur les pièces mobiles. No ponga la mano sobre las piezas móviles. Não coloque a mão nas peças móveis. Не кладите руку на движущиеся части. 기동부에 손을 대지 마십시오 可動部に手を置かないでください。</p>	<p>You may get your hand or fingers caught when bringing your hand close to moving parts.</p>
E	 <p>警告 WARNING 警告 AVERTISSEMENT 警告 ADVERTENCIA 警告 ATENÇÃO 警告 ОСТОПЖНО</p> <p>当心落下 FALLING HAZARD 当心落下 RISQUE DE CHUTE 落下の危険 PELIGRO DE CAIDAS 낙 위험 PERIGO DE QUEDA ОПАСНОСТЬ ПАДЕНИЯ</p> <p>緊急制動釋放 1. 关闭控制器 2. 按照制動釋放單元上的說明操作制動釋放單元。 緊急制動釋放 1. 關閉控制器 2. 按照制動釋放單元上的說明操作制動釋放單元。 EMERGENCY BRAKE RELEASE 1. Turn off the controller. 2. Operate the brake release unit using instructions on the brake release unit. DESSERRAGE DU FREIN D'URGENCE 1. Éteindre le contrôleur. 2. Utiliser l'élément de desserrage de frein à l'aide des instructions sur l'élément de desserrage de frein. LIBERACION DEL FRENO EN CASO DE EMERGENCIA 1. Apague el controlador. 2. Opere la unidad de liberación del freno siguiendo las instrucciones de la unidad de liberación del freno. LIBERAÇÃO DO FREIO DE EMERGENCIA 1. Desligue o controlador. 2. Para operar a liberação do freio de emergência, siga as instruções de cada unidade para liberar o freio. АВАРИЙНОЕ ОТКЛЮЧЕНИЕ ТОРМОЗА 1. Выключите контроллер. 2. Выполните операцию растормаживания, следуя инструкциям на блоке растормаживания. 비상 브레이크 해제 1. 비상 컨트롤러 전원을 차단해 주십시오. 2. 브레이크 해제 장치의 지침에 따라서 브레이크 해제 손실을 최소화 하십시오. 緊急ブレーキリリース 1. コントローラーの電源を切ります。 2. ブレーキ解除ユニットの指示に従ってブレーキ解除ユニットを操作します。</p>	<p>When releasing the brakes, be careful of the arm falling due to its own weight.</p> <p>This warning label is attached on the Manipulator and optional brake release unit as well.</p> <p>When the brake release unit is used: Details of procedures for releasing the brakes using the brake release unit are described in the Manipulator manuals.</p>
F	 <p>注意 CAUTION 注意 ATTENTION 注意 ATENCIÓN 注意 CUIDADO 注意 주의</p> <p>小心起吊 LIFT WITH CARE 小心起吊 SOULEVEZ AVEC SOIN 持ち上げ注意 LEVANTAR COM CUIDADO 주의해서 들어 올리십시오 LEVANTE COM CUIDADO ПОДНИМАЙТЕ ОСТОРОЖНО</p> <p>在起吊和運輸過程中，請遵照說明手冊。 在起吊和運輸過程中，請遵照說明手冊。 Follow instructions manual during lifting and transportation. Respecter les instructions du manuel d'utilisation pendant le levage et le transport. Siga el manual de instrucciones durante la instalación y el transporte. Siga as instruções do manual para lidar o transportar o robô. При подъеме и транспортировке следуйте инструкциям в руководстве. 로봇 운반시 사용설명서를 따라 주십시오. 持ち上げ注意 輸送は、取扱説明書に従ってください。</p>	<p>Only authorized personnel should perform sling work and operate a crane and a forklift.</p> <p>When these operations are performed by unauthorized personnel, it is extremely hazardous and may result in serious bodily injury and/or severe equipment damage to the robot system.</p>

Location	Warning Label	NOTE
G		<p>HOT Be careful not to burn yourself.</p>

Location	Label	NOTE
1	-	<p>The product name, model name, serial number, information which laws and regulations are supported, product specifications, manufacturer, importer, date of manufacture, country of manufacture, etc. are listed. For details, see the label affixed to the product.</p>

Location of Labels

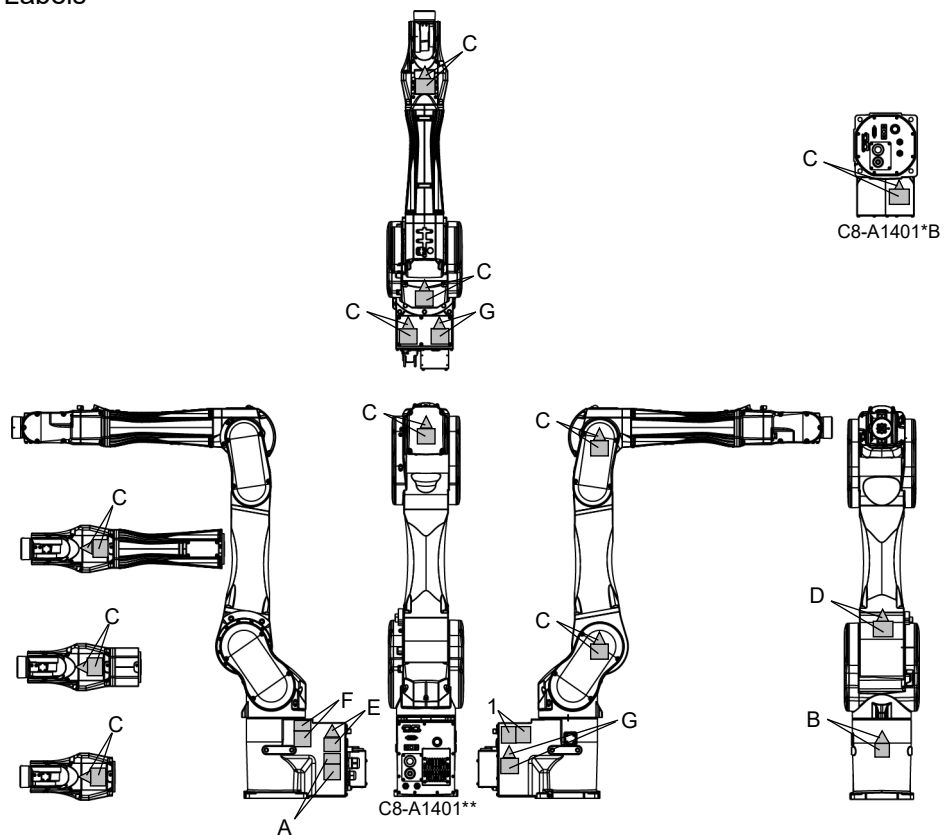

1.9 Response for Emergency or Malfunction

1.9.1 Collision

When the Manipulator collides with a mechanical stopper or peripheral device etc., discontinue use and contact the supplier.

1.9.2 Getting body caught in Manipulator

When the operator is caught between the Manipulator and a mechanical part such as a base table, press the emergency stop switch to release the brake on the subject arm, and then move the arm by hand.

How to release a brake

When using a brake release unit

For details, refer to “*6.1 Brake Release Unit*”.

When using software

For details, refer to “*1.6.2 Moving the Arm using the software*”.

2. Specifications

2.1 Model Number

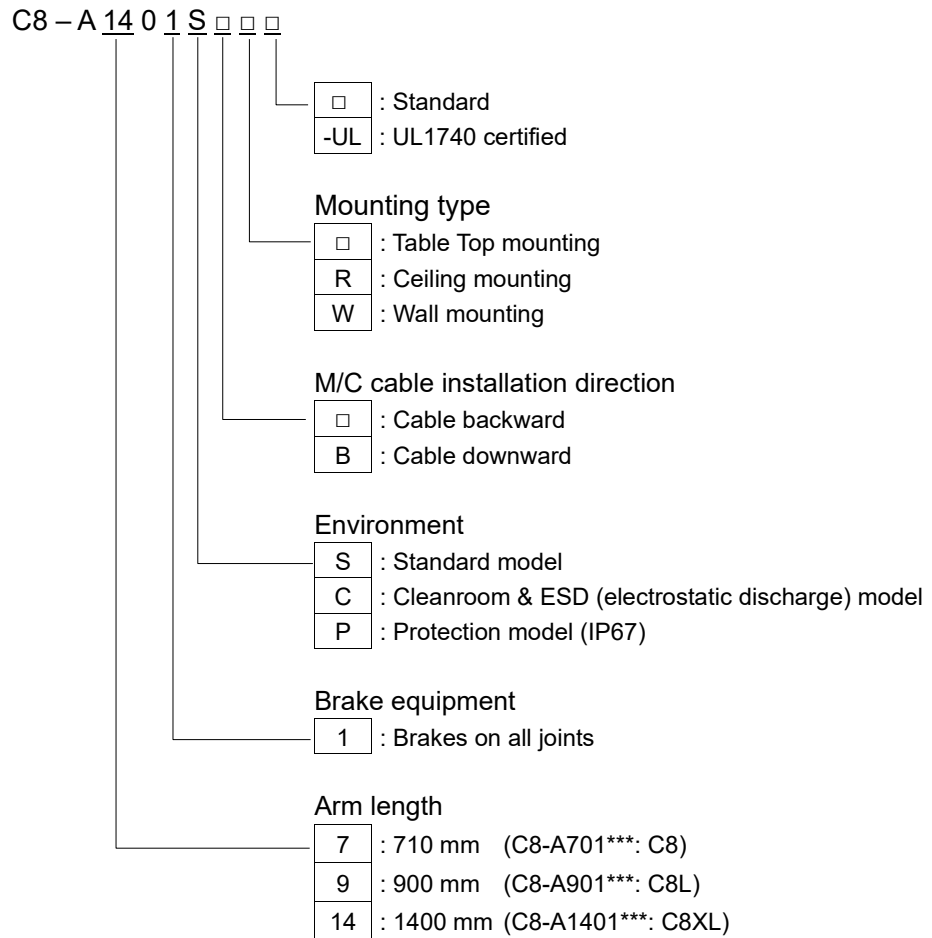

Example

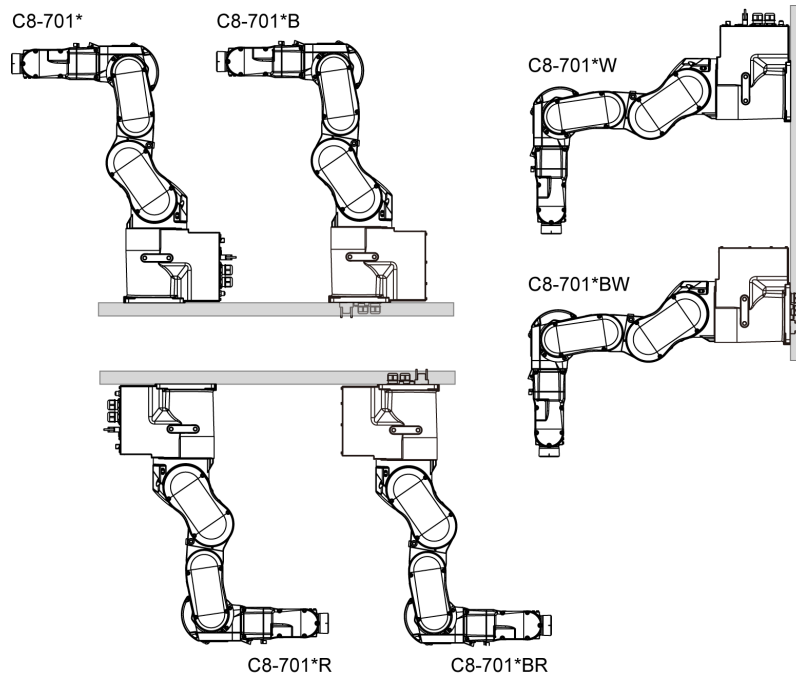

2.2 Part Names and Motion Range of Each Arm

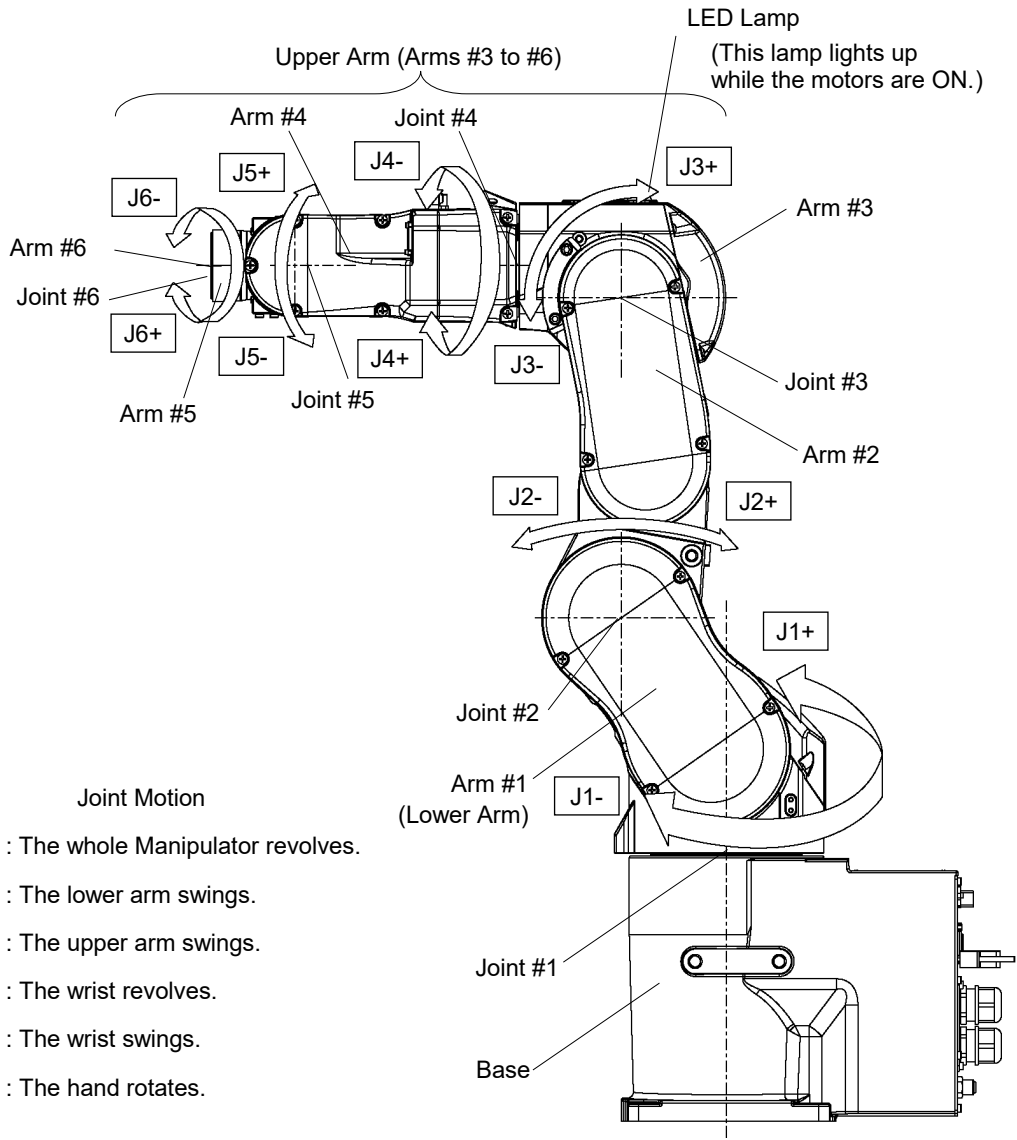

- Joint Motion
- Joint #1 : The whole Manipulator revolves.
 - Joint #2 : The lower arm swings.
 - Joint #3 : The upper arm swings.
 - Joint #4 : The wrist revolves.
 - Joint #5 : The wrist swings.
 - Joint #6 : The hand rotates.

(Figure: C8-A701* (C8))

NOTE When the LED lamp is lighting or the Controller power is on, current is being applied to the Manipulator. (The LED lamp may not be seen depending on the Manipulator's posture. Be very careful.)
 Performing any work with the power ON is extremely hazardous and it may result in electric shock and/or improper function of the robot system. Make sure to turn OFF the Controller power before the maintenance work.

Cable backward model

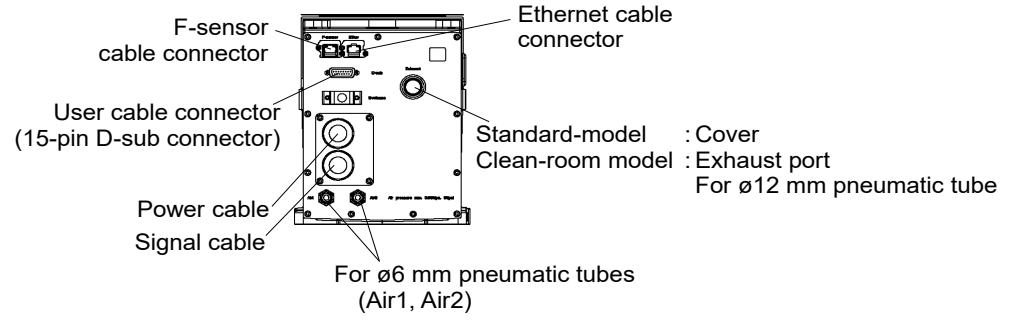

Cable downward model

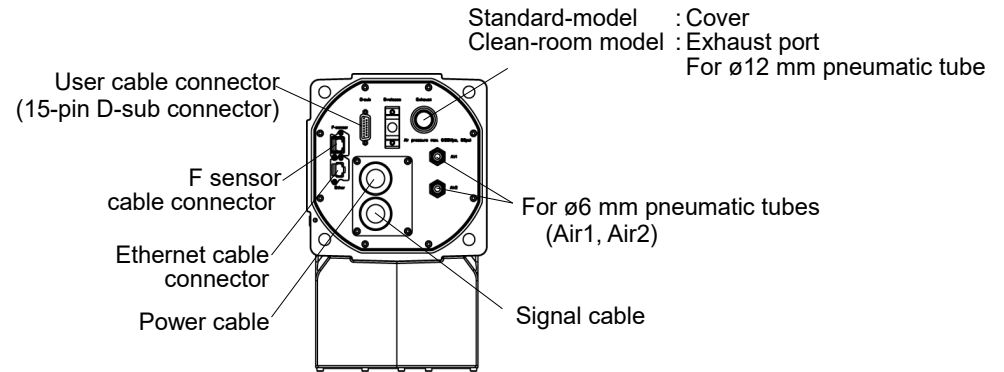

Cable backward model / Cable downward model

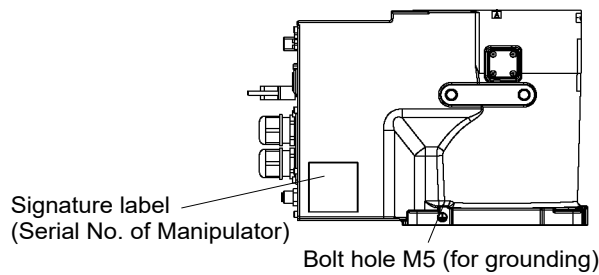

(Figure: Cable backward model)

2.3 Outer Dimensions

[Unit: mm]

2.3.1 C8-A701*** (C8)

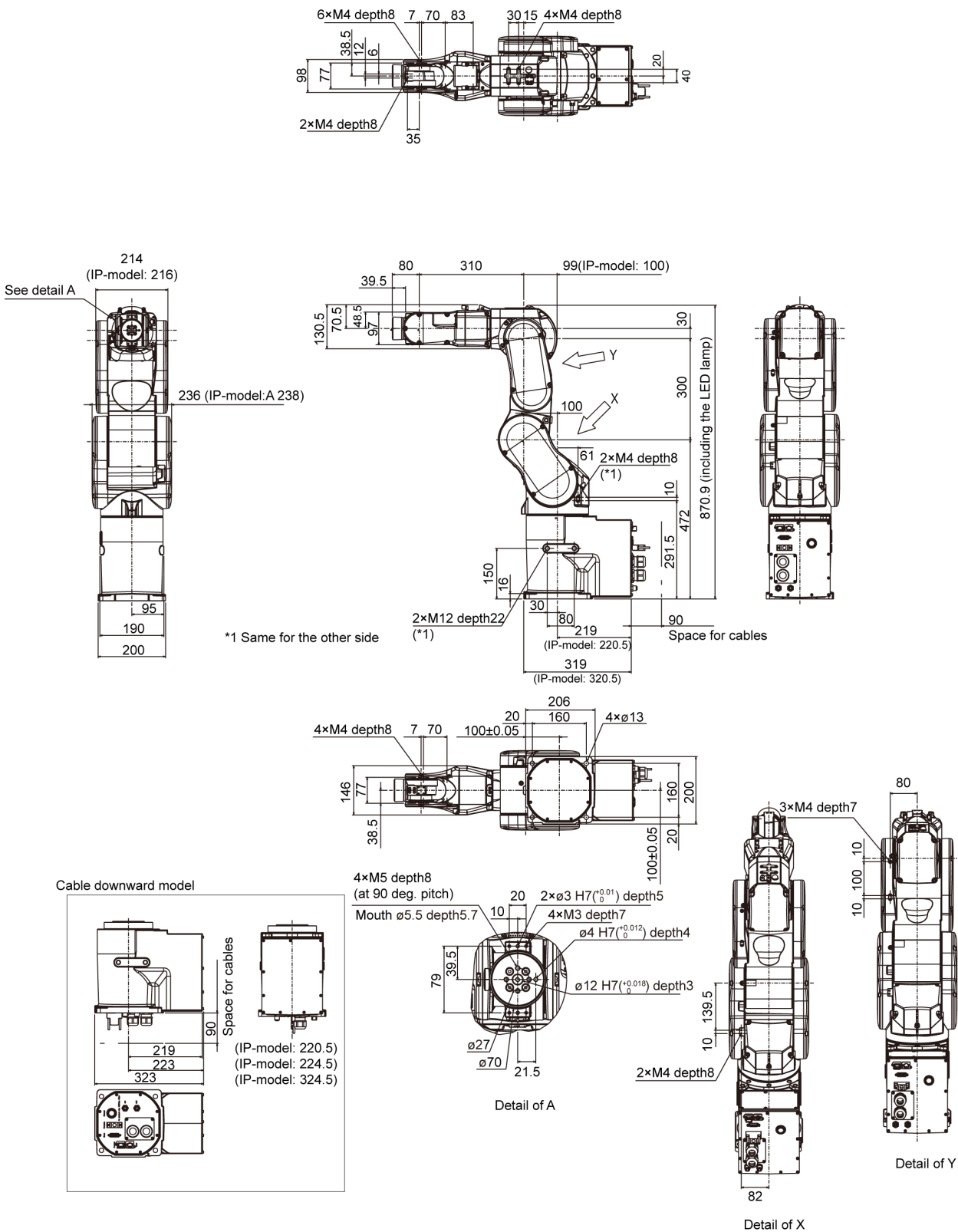

2.3.2 C8-A901*** (C8L)

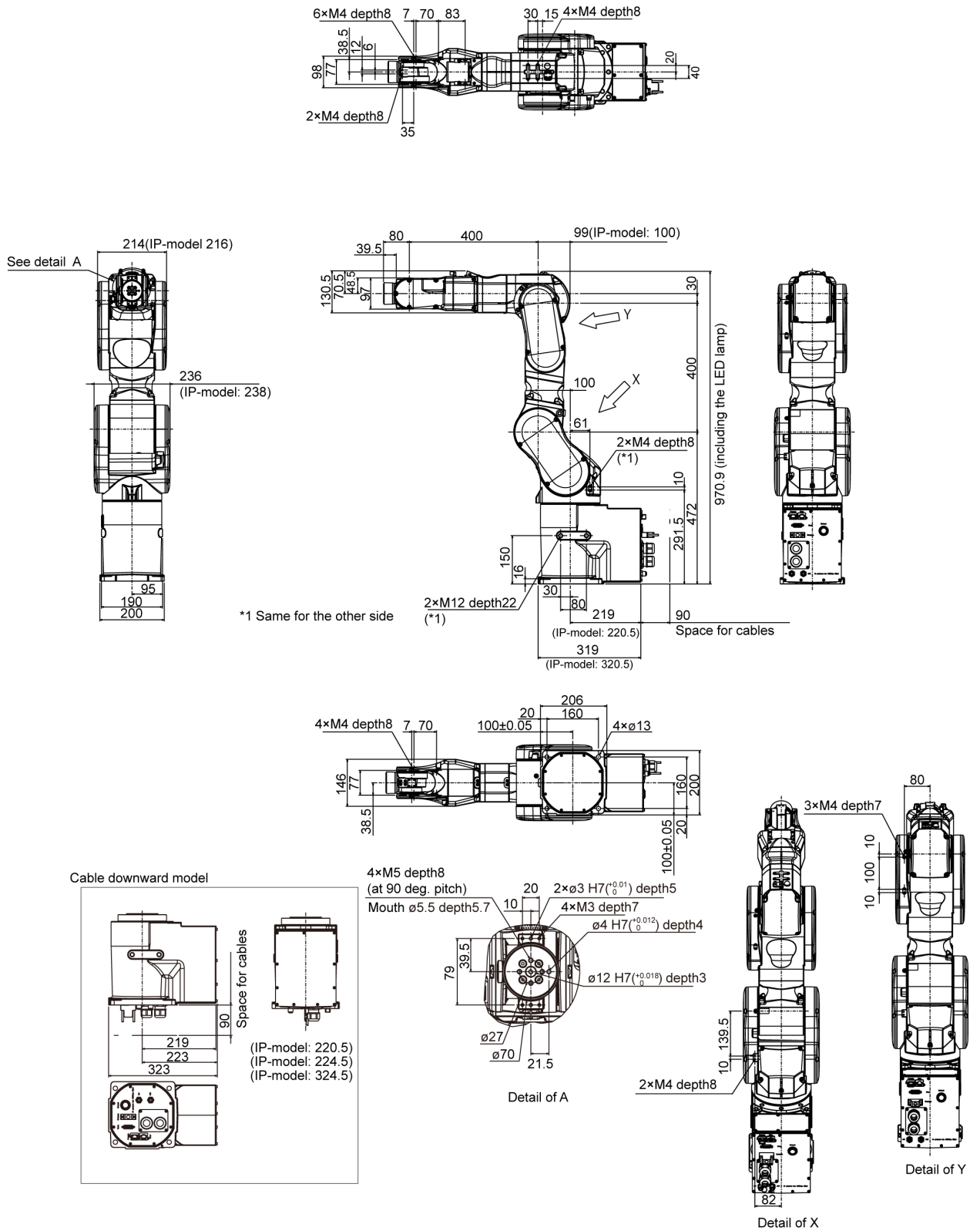

2.3.3 C8-A1401*** (C8XL)

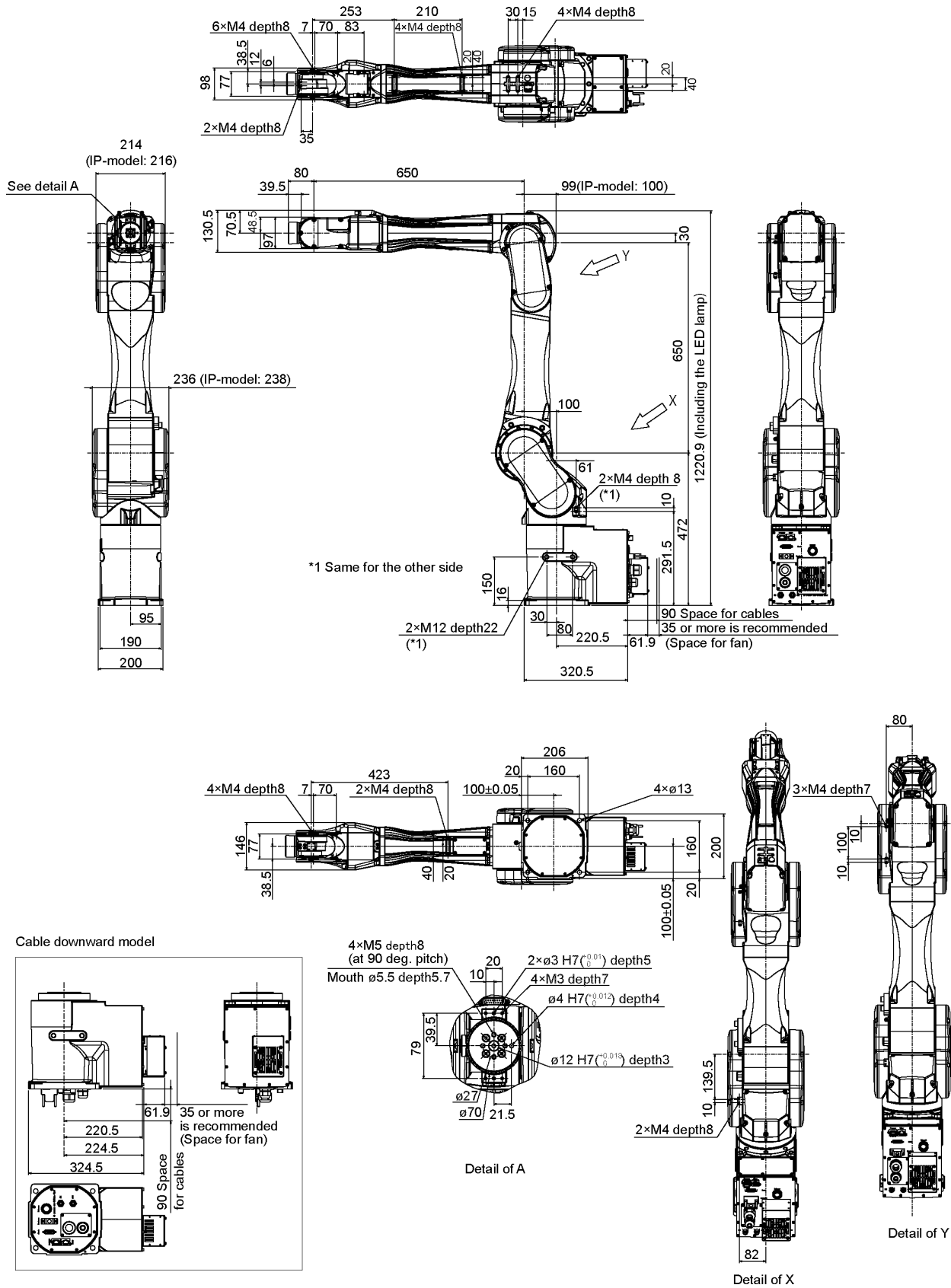

2.4 Standard Motion Range

2.4.1 C8-A701*** (C8)

[Unit: mm]

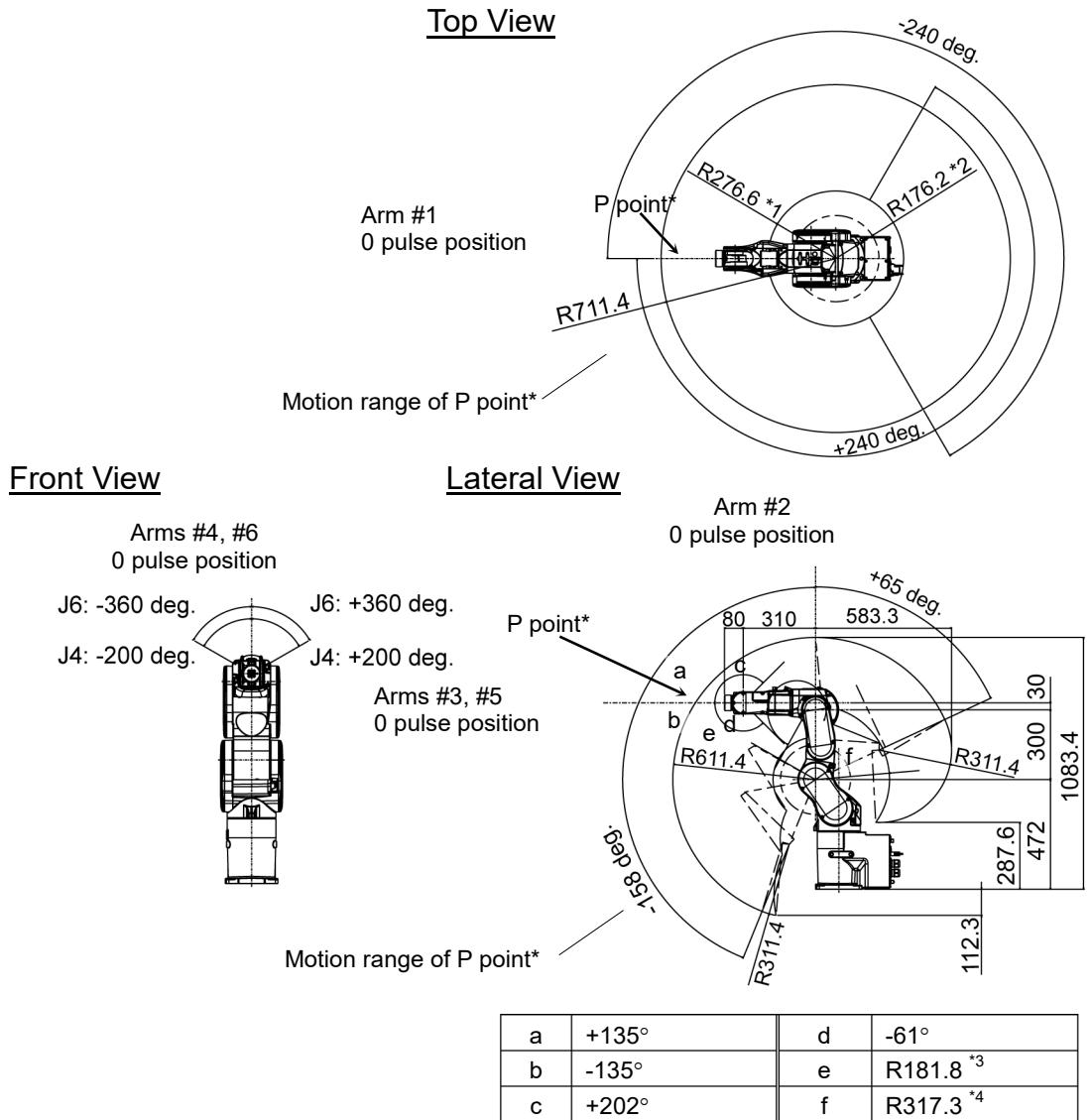

(deg.=°)

- * P point : Intersection of the rotation centers for Joints #4, #5, and #6
- *1 : P point from top with Joint #3 declining -61° (Joint #1 center – P point center)
- *2 : P point from top with Joint #3 tilting up +202° (Joint #1 center – P point center)
- *3 : P point from lateral with Joint #3 declining -61° (Joint #2 center – P point center)
- *4 : P point from lateral with Joint #3 tilting up +202° (Joint #2 center – P point center)

 CAUTION	<p>■ Pay attention to the arm pose of the basic arms (Arms #1, #2, and #3) when operating the Manipulator. Arm #5 moves keeping a constant angle regardless of the arm pose. Depending on the arm pose of the basic arms, the wrist may collide with the Manipulator. The collision may cause equipment damage to and/or malfunction of the Manipulator.</p>
---	--

2.4.2 C8-A901*** (C8L)

[Unit: mm]

Top View

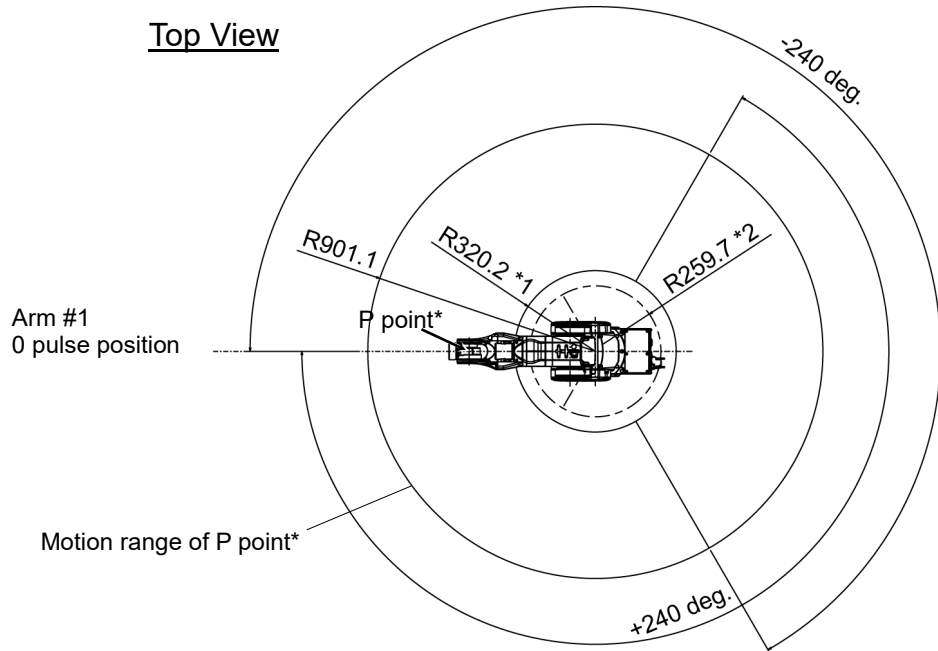

Front View

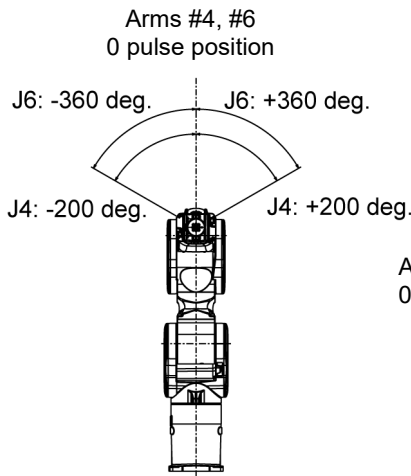

Lateral View

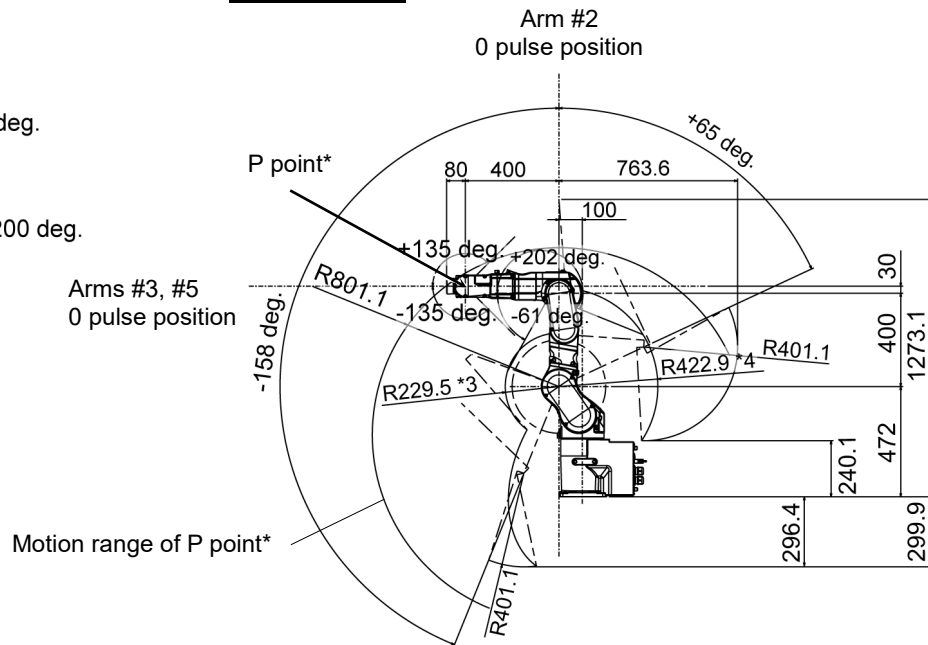

(deg.=°)

- * P point : Intersection of the rotation centers for Joints #4, #5, and #6
- *1 : P point from top with Joint #3 declining -61° (Joint #1 center – P point center)
- *2 : P point from top with Joint #3 tilting up $+202^\circ$ (Joint #1 center – P point center)
- *3 : P point from lateral with Joint #3 declining -61° (Joint #2 center – P point center)
- *4 : P point from lateral with Joint #3 tilting up $+202^\circ$ (Joint #2 center – P point center)

 CAUTION	<p>■ Pay attention to the arm pose of the basic arms (Arms #1, #2, and #3) when operating the Manipulator. Arm #5 moves keeping a constant angle regardless of the arm pose. Depending on the arm pose of the basic arms, the wrist may collide with the Manipulator. The collision may cause equipment damage to and/or malfunction of the Manipulator.</p>
--------------------	--

2.4.3 C8-A1401*** (C8XL)

[Unit: mm]

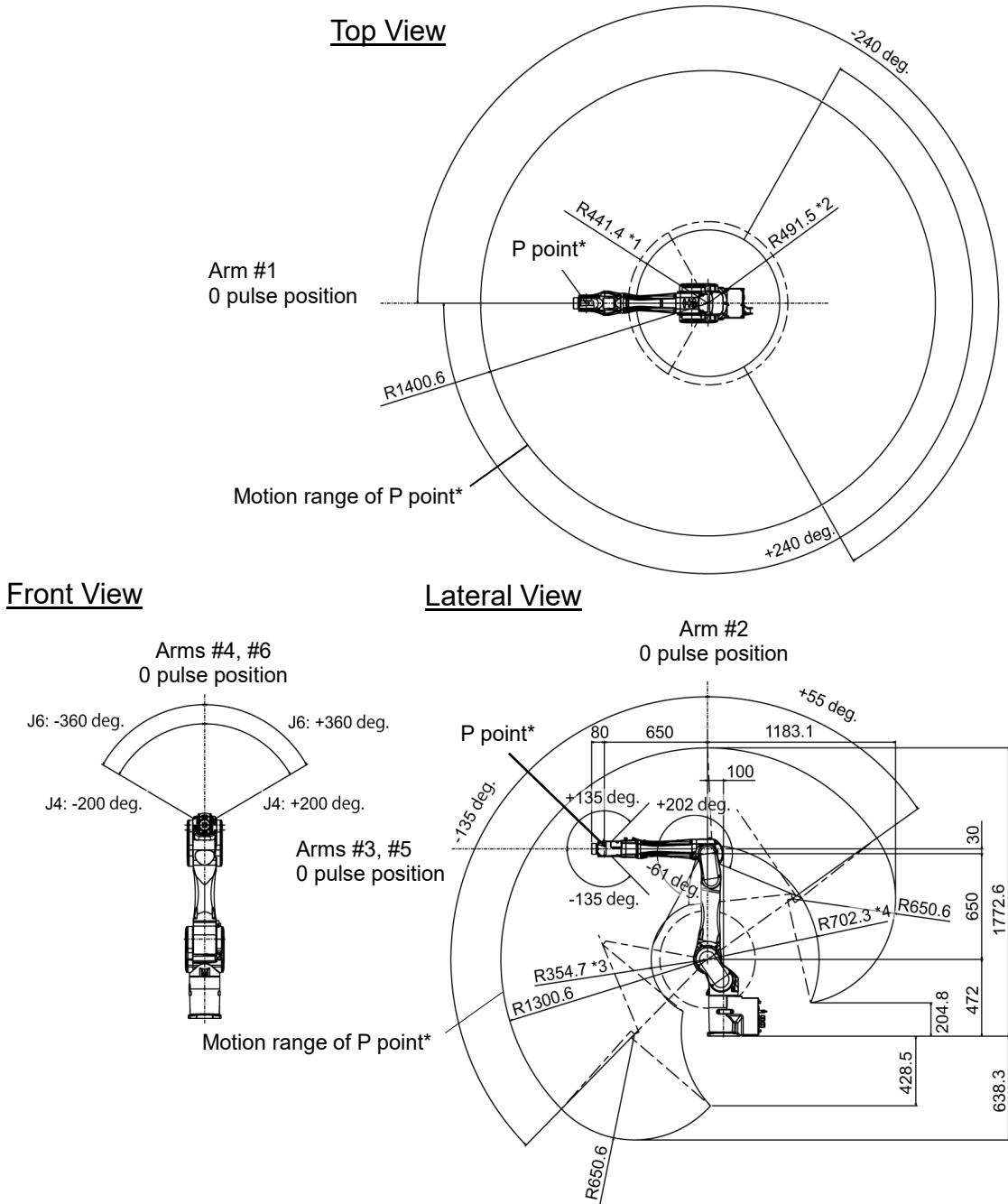

(deg.=°)

- * P point : Intersection of the rotation centers for Joints #4, #5, and #6
- *1 : P point from top with Joint #3 declining -61° (Joint #1 center – P point center)
- *2 : P point from top with Joint #3 tilting up $+202^\circ$ (Joint #1 center – P point center)
- *3 : P point from lateral with Joint #3 declining -61° (Joint #2 center – P point center)
- *4 : P point from lateral with Joint #3 tilting up $+202^\circ$ (Joint #2 center – P point center)

 CAUTION	<p>■ Pay attention to the arm pose of the basic arms (Arms #1, #2, and #3) when operating the Manipulator. Arm #5 moves keeping a constant angle regardless of the arm pose. Depending on the arm pose of the basic arms, the wrist may collide with the Manipulator. The collision may cause equipment damage to and/or malfunction of the Manipulator.</p>
---	--

2.5 Specifications

2.5.1 Specifications Table

For the specification of each model, refer to “*Appendix A: Specifications Table*”.

2.5.2 Option

C8 series have the following options.

For details of options, refer to “*6. Options*”.

User wires and pneumatic tube

Standard user connector kit	: Standard D-sub 15-pin × 2
Waterproof user connector kit	: IP67 waterproof D-sub 15-pin × 2 IP67 waterproof for RJ45 × 2
Fittings for customer use	: ø6, straight × 2 ø6, elbow × 2

Adjustable mechanical stop

Adjustable mechanical stop	: J1 C8/C8L_J2 C8XL_J2 J3
----------------------------	------------------------------------

Tool adapter

C8 ISO flange (J6)

Camera plate unit

Camera mounting tool (common for C3 and C4 series)

Brake release unit *1

For EU (power supply voltage 200 V, short connector included)

For US/JP (power supply voltage 100 V, short connector included)

Short connector for the brake release unit

*1: When using the brake release unit with C8 series, it is necessary to connect the short connector to the M/C power cable or connect the M/C power cable with the Controller. (The brake release unit can be used while the Controller is de-energized state.)

If you are using C3 or C4 series Manipulator and already have the brake release unit, you can use it by connecting the M/C cable with the Controller, or purchasing the short connector separately and connecting it to the M/C power cable.

2.6 How to Set the Model

The Manipulator for your system has been set before shipment.



- When you need to change the setting of the Manipulator model, be sure to set the Manipulator model properly. Improper setting of the Manipulator model may result in abnormal or no operation of the Manipulator and/or cause safety problems.



If the custom specifications number (MT***) or (X***) is described on the signature label (S/N label), the Manipulator has custom specifications. (A label with only the custom specifications number may be attached depending on shipment time.)

The custom specifications may require a different configuration procedure; check the custom specifications number and contact the supplier of your region when necessary.

The Manipulator model can be set from software.

Refer to the chapter *Robot Configuration* in the *Epson RC+ User's Guide*.

3. Environment and Installation

Unpacking and transportation of the Manipulators and robotic equipment shall be performed by personnel who has taken robot system training held by us and suppliers and should conform to all national and local codes.

3.1 Environmental Conditions

A suitable environment is essential for the robot system to function properly and safely. Be sure to install the robot system in an environment that meets the following conditions:

Item	Conditions
Ambient temperature* ¹	5 to 40 °C
Ambient relative humidity	10 to 80 % (no condensation)
Fast transient burst noise	1 kV or less (Signal wire)
Electrostatic noise	4 kV or less
Altitude	1000 m or lower
Environment	<ul style="list-style-type: none"> - Install indoors - Keep away from direct sunlight - Keep away from dust, oily smoke, salinity, metal powder or other contaminants - Keep away from flammable or corrosive solvents and gases - Keep away from water - Keep away from shock or vibration - Keep away from sources of electric noise - Keep away from explosive area - Keep away from a large quantity of radiation

*1 The ambient temperature conditions are for the Manipulators only. For the Controller which the Manipulator is connected to, refer to the Robot Controller manual.

When the product is used in a low temperature environment around the minimum temperature of the product specification, or when the product is suspended for a long time on holidays or at night, a collision detection error may occur due to the large resistance of the drive unit immediately after the start of operation. In such a case, it is recommended to warm up for about 10 minutes.



When using the Manipulators in inadequate environments that do not meet the above conditions, please contact the distributor.

For the Protection-model Manipulator, be sure to install the robot system in an environment that also meets the following conditions:

Item	Conditions
Environment	<ul style="list-style-type: none"> - Install indoors - Keep away from direct sunlight - Keep away from dust, oily smoke, salinity, metal powder or other contaminants - Keep away from flammable or corrosive solvents and gases - Keep away from organic solvents, acids, alkalis, and chlorine cutting fluids - Do not use in water - Keep away from shock or vibration - Keep away from sources of electric noise - Available under the environment with dust, oily smoke, and metal *2 - Keep away from explosive area - Keep away from a large quantity of radiation

*1 The Manipulator body is mainly made of iron and aluminum. It is not rust-proofed. Do not use the Manipulator under conditions where it can be exposed to water or any other corrosive liquid (including water).

*2 Any contaminants that can deteriorate sealing performance of nitrile rubber oil sealing, O-rings, packing seals and liquid gasket should be avoided.

Special Environmental Conditions

The protective seals are attached on the Protection-model Manipulator to prevent dust, water, etc. from the outside. Follow the precautions in use environment described below:

The surface of the Manipulator has general oil resistance. However, if your requirements specify that the Manipulator must withstand certain kinds of oil, please the supplier of your region.

Rapid change in temperature and humidity can cause condensation inside the Manipulator. If your requirements specify that the Manipulator handles food, please the supplier of your region to check whether the Manipulator will damage the food or not.

The Manipulator cannot be used in corrosive environments where acid or alkaline is used. In a salty environment where the rust is likely to gather, the Manipulator is susceptible to rust.

The Controller used with the Protection-model Manipulator does not have protection features for dusty, wet, or oily environment. The Controller must be placed in an environment that meets the specified conditions.

 WARNING	<ul style="list-style-type: none"> ■ Use an earth leakage breaker on the AC power cable of the Controller to avoid the electric shock and circuit breakdown caused by an unexpected water leak. Prepare the earth leakage breaker that pertains the Controller you are using. For details, refer to the Robot Controller manual.
--	---

 CAUTION	<ul style="list-style-type: none"> ■ When cleaning the Manipulator, do not rub it strongly with alcohol or benzene. It may lose luster on the coated face.
--	---

3.2 Unpacking, Transportation, and Relocation

Using a cart or similar equipment, transport the Manipulator in the same conditions as it was delivered. Observe the following when unpacking the Manipulator.

Unpacking, transportation, and relocation shall be performed by personnel who has taken robot system training held by us and suppliers and should conform to all national and local codes.



WARNING

- Only authorized personnel should perform sling work and operate a crane or a forklift. When these operations are performed by unauthorized personnel, it is extremely hazardous and may result in serious bodily injury and/or severe equipment damage to the robot system.
- Stabilize the Manipulator with your hands when hoisting it. Unstable hoisting is extremely hazardous and may result in serious bodily injury and/or severe equipment damage to the robot system as the fall of the Manipulator.



CAUTION

- When removing the anchor bolts, support the Manipulator to prevent falling. Removing the anchor bolts without supporting the Manipulator may get hands, fingers, or feet caught as the Manipulator may fall.
- To transport the Manipulator, secure it to the delivery equipment or have at least 2 people to hold it by hand. Also, do not hold the bottom of the base (the screened parts in the figure). Holding these parts by hand is extremely hazardous and may cause your hands and fingers caught.

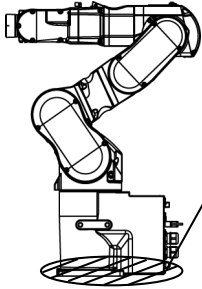



Figure: C8-A901* (C8L)
DO NOT hold the bottom of the base by hand.

Manipulator weight	C8-A701***: C8	C8-A901***: C8L	C8-A1401***: C8XL
Standard, Cleanroom	49 kg: 108 lbs.	52 kg: 115 lbs.	62 kg: 137 lbs.
Protection	53 kg: 117 lbs.	56 kg: 123 lbs.	66 kg: 146 lbs.

- Avoid excessive vibration or shock during Manipulator transporting. Excessive vibration or shock may cause equipment damage to and/or malfunction of the Manipulator.
- Take extra care when transporting the Manipulator. You may hit and damage the connector



Be sure to transport and store the robot system in environments that meet the following conditions:

Item	Conditions
Ambient temperature	-20 to 60 °C
Ambient relative humidity	10 to 90 % (no condensation)

During unpacking and relocation, avoid applying external force to the arms and motors of the Manipulator.

When transporting the Manipulator for a long distance, secure it to the delivery equipment so that the Manipulator cannot fall. If necessary, pack the Manipulator in the same way as it was delivered.

When condensation occurs on the Manipulator during transport or storage, turn ON the power only after the condensation dries.

When using the Manipulator for the robot system again after long-term storage, perform a test run to verify that the Manipulator works properly. Then, operate the Manipulator thoroughly.

Relocating

Follow the procedures described below when relocating the Manipulator.

- (1) Turn OFF the power for all devices and unplug the power cable connector and signal cable connector from the Controller.

Do not unplug the M/C cable (power cable and signal cable) from the Manipulator. (M/C cable 3 m: 2 kg)



Remove the mechanical stops if using them to limit the motion range.

For details on the motion range, refer to “5.2 Motion Range Setting by Mechanical Stops”.

- (2) Unscrew the anchor bolts. Then, remove the Manipulator from the base table.
- (3) Position the Manipulator as shown in the figure. Then, secure the Manipulator to the delivery equipment or have at least 2 people to carry the Manipulator.

Recommend: Joint #2 +55°

Joint #3 -55°

* The posture is common to all models.

Do not hold the bottom of the base (the screened parts in the figure). Holding these parts by hand is extremely hazardous and may cause your hands and fingers to be caught.

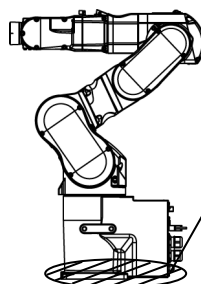

Figure: C8-A901* (C8L)
DO NOT hold the bottom of the base by hand.

Manipulator weight

	C8-A701***: C8	C8-A901***: C8L	C8-A1401***: C8XL
Standard, Cleanroom	49 kg: 108 lbs.	52 kg: 115 lbs.	62 kg: 137 lbs.
Protection	53 kg: 117 lbs.	56 kg: 123 lbs.	66 kg: 146 lbs.

Using Eyebolt

Check that the eyebolts are securely fastened before carrying the Manipulator.
 After transporting the Manipulator, remove the eyebolts and keep them for future use.
 The eyebolts (accessory, 2 pcs) and wire must be strong enough to withstand the weight (See the figures below).
 If you use the eyebolts to lift up the Manipulator, make sure to put hands on it to keep the balance. The Manipulator may fall if the balance is lost and this is extremely hazardous.
 To prevent damage on the covers and arms, it is recommended to protect the contacting parts of the wire and arm with a cloth. Be very careful not to damage the covers since they are made of plastic.

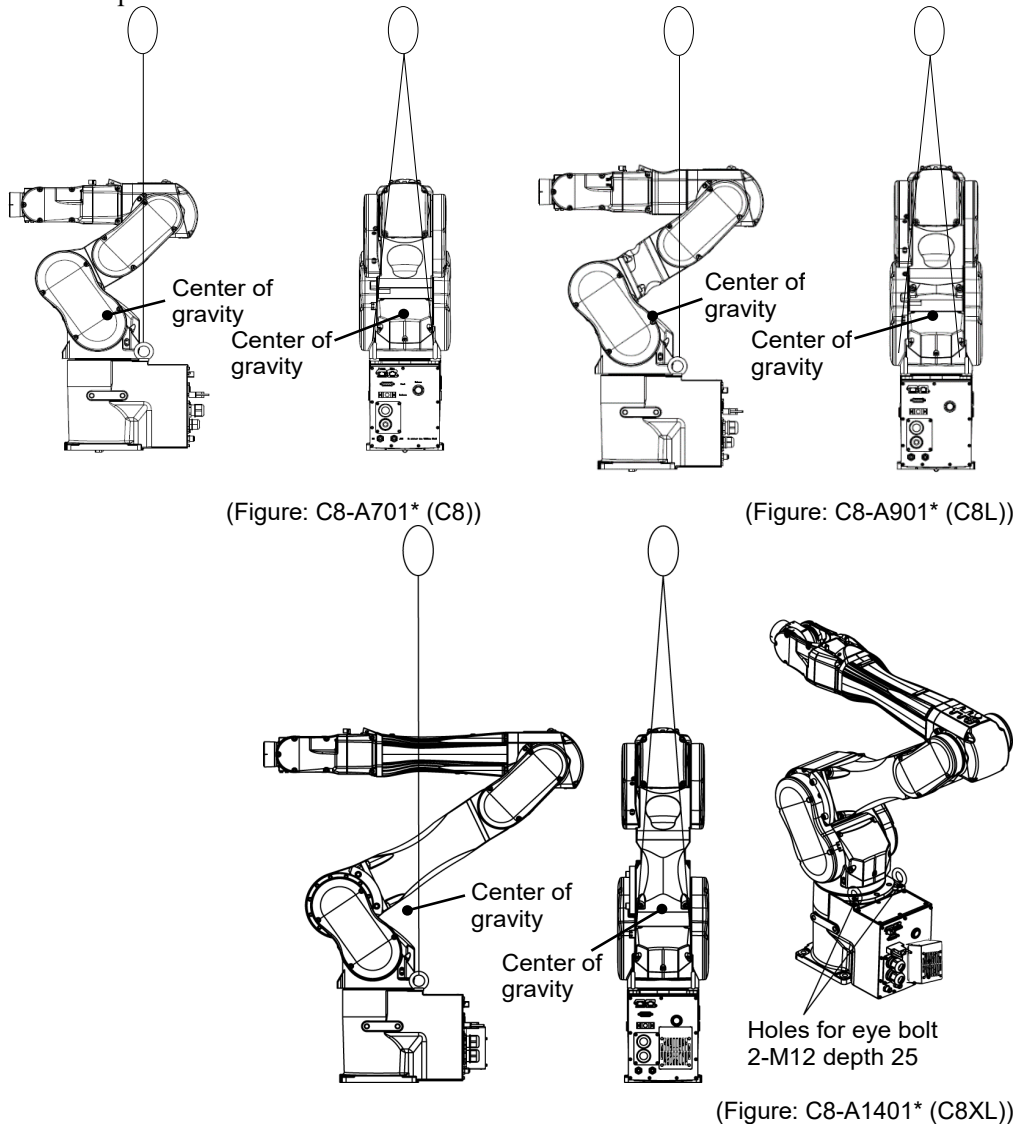

* Locations of the screw holes for eyebolts are common to all models.

Manipulator weight

	C8-A701***: C8	C8-A901***: C8L	C8-A1401***: C8XL
Standard, Cleanroom	49 kg: 108 lbs.	52 kg: 115 lbs.	62 kg: 137 lbs.
Protection	53 kg: 117 lbs.	56 kg: 123 lbs.	66 kg: 146 lbs.

 CAUTION	<ul style="list-style-type: none"> ■ Remove the eyebolts from the Manipulator after transportation/relocation is completed. <p>If the Manipulator is operated with the eyebolts left on it, the arm may collide with the eyebolts and it may cause equipment damage to and/or malfunction of the Manipulator.</p>
--	--

3.3 Mounting Dimensions

Mounting Area

Be sure to have the following space available in addition to the space for mounting the Manipulator, Controller, and peripheral equipment.

- Space for teaching points
- Space for maintenance and inspections (for installing jigs)
- Space for cables

NOTE  When installing the cable, be sure to maintain sufficient distance from obstacles.
 For the minimum bend radius of the MC cable, refer to "Appendix A: C8 Specifications."
 In addition, leave enough space for other cables so that they are not bent forcibly.

NOTE  In case of C8-A1401*** (C8XL):
 Make sure to leave 35 mm or more space around the fan cover.

[Unit: mm]

3.3.1 Cable Backward Model

C8-A701** (C8)

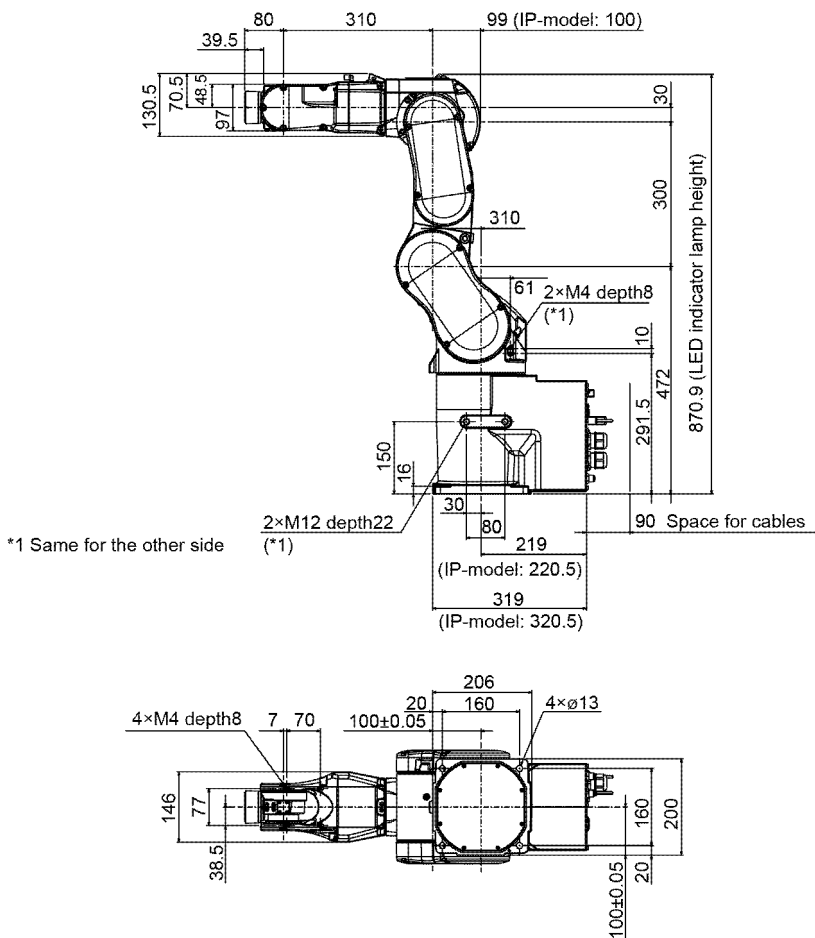

*1 Same for the other side

C8-A901** (C8L)

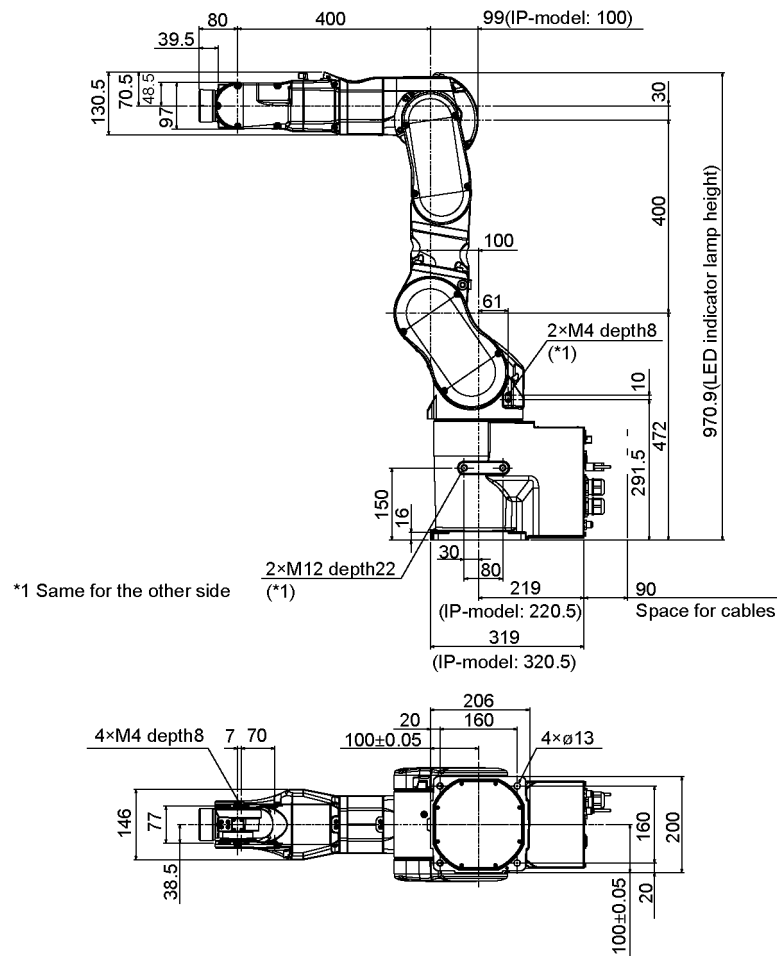

C8-A1401** (C8XL)

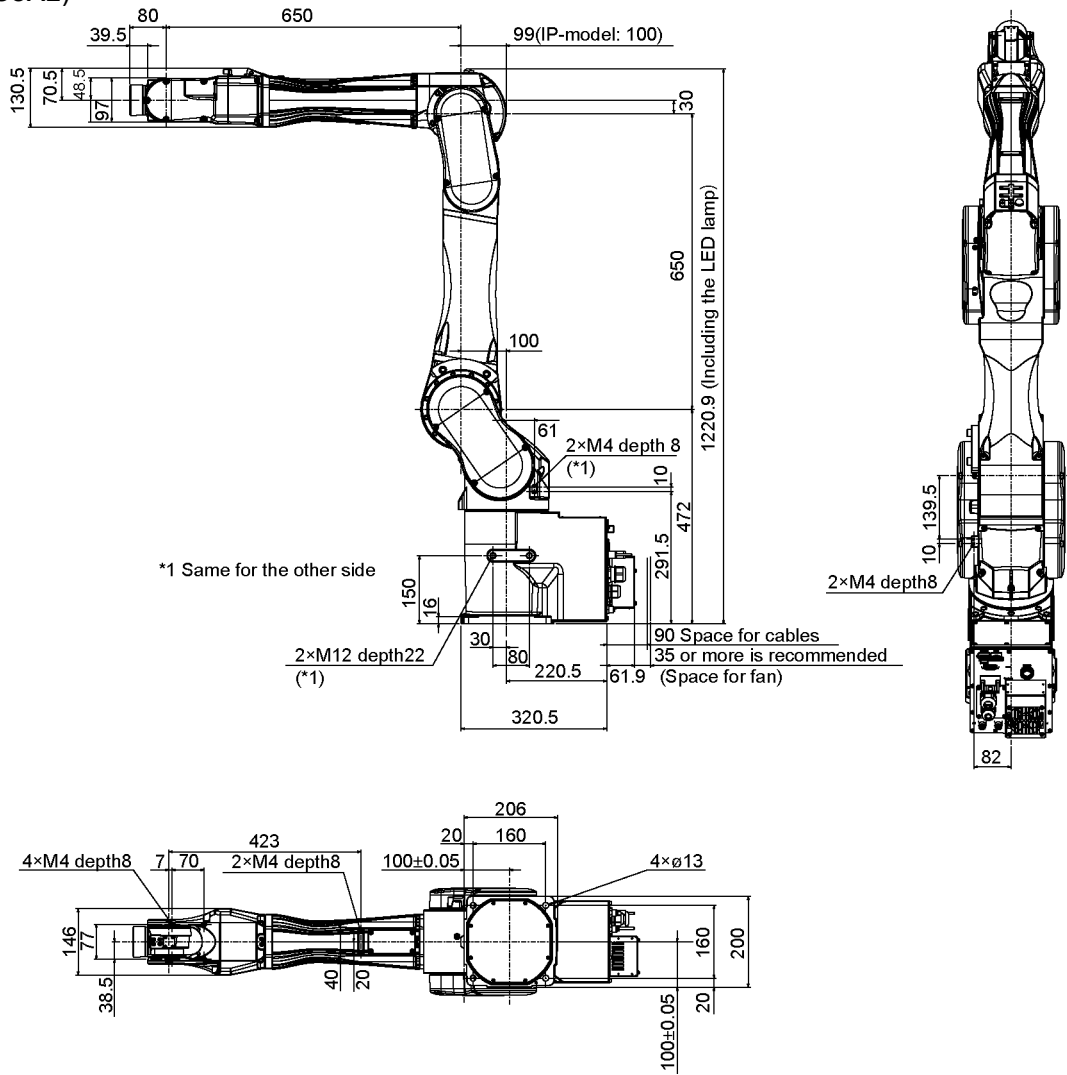

3.3.2 Cable Downward Model

The following part differs from the cable backward model.

C8-A701*B* (C8), C8-A901*B* (C8L) C8-A1401*B* (C8XL)

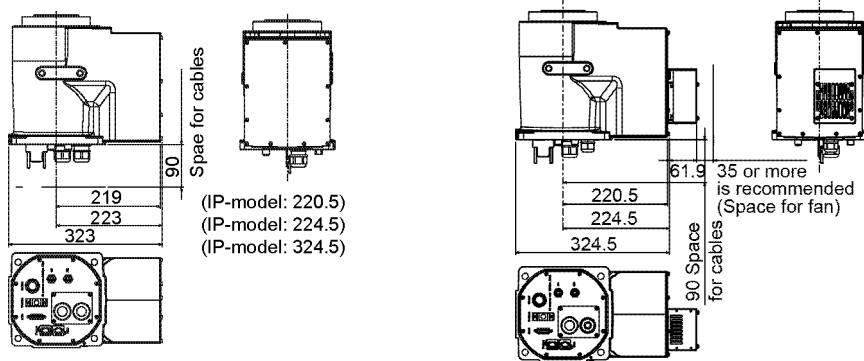

3.4 Installation

The installation shall be made by personnel who has taken robot system training held by us and suppliers and should conform to all national and local codes.

 WARNING	<ul style="list-style-type: none"> ■ To ensure safety, a safeguard must be installed for the robot system. For details on the safeguard, refer to the <i>Installation and Design Precautions</i> in the <i>Safety</i> chapter of the Epson RC+ User's Guide. ■ Install the Manipulator in a location with sufficient space so that a tool or a work piece does not touch a wall or a safeguard when the Manipulator extends its arm fully while holding a work piece. Installing the Manipulator at a location with insufficient space is extremely hazardous and may result in serious bodily injury and/or severe equipment damage to the robot system as a tool or a work piece may collide with a wall or a safeguard. ■ Anchor the Manipulator before turning ON the power to or operating the Manipulator. Turning ON the power to or operating the Manipulator that is not anchored is extremely hazardous and may result in serious bodily injury and/or severe equipment damage to the robot system as the Manipulator may fall down. ■ Before installing and operating the Manipulator, make sure that all parts of the Manipulator are in place and have no external defects. Missing or defective parts may cause improper operation of the Manipulator. Improper operation of the Manipulator is extremely hazardous and may result in serious bodily injury and/or severe equipment damage to the robot system.
---	---

 CAUTION	<ul style="list-style-type: none"> ■ The Manipulator must be installed to avoid interference with buildings, structures, utilities, other machines and equipment that may create a trapping hazard or pinch points. ■ Oscillation (resonance) may occur during operation depending on rigidity of the installation table. If the oscillation occurs, improve rigidity of the table or change the speed or acceleration and deceleration settings. ■ C8-A1401** has a cooling fan on the base. Install the Manipulator not to seal the cooling fan. (For details, refer to "3.3 Mounting Dimensions C8-A1401**")
---	--

Protective Tape

Remove the protective tape (4 places).

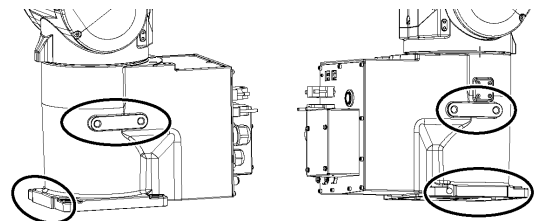

Mounting bolt

For the dimensions, refer to “3.3 Mounting Dimensions”.

There are four threaded holes for the Manipulator base.

Use M12 mounting bolts conforming to the strength equivalent to ISO898-1 property class 10.9 or 12.9.

Tightening torque:

$$100.0 \pm 5.0 \text{ N}\cdot\text{m} \text{ (1,020} \pm 51 \text{ kgf}\cdot\text{cm)}$$

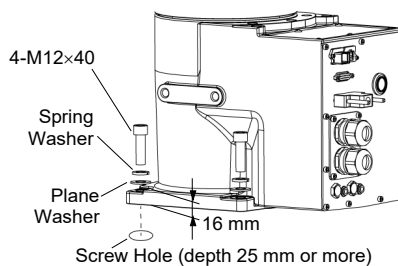

Base table

A base table for anchoring the Manipulator is not supplied. Please make or obtain the base table for your Manipulator. The shape and size of the base table differ depending on the intended use of the robot system. The following is the basic requirements of Manipulator table for your reference.

The base table must not only be able to bear the weight of the Manipulator but also be able to withstand the dynamic movement of the Manipulator when it operates at maximum acceleration/deceleration. Ensure that there is enough strength on the base table by attaching reinforcing materials such as crossbeams.

The torque and reaction force produced by the movement of the Manipulator are as follows:

Model number	C8-A701***	C8-A901***	C8-A1401***
Model name	C8	C8L	C8XL
Max. Horizontal rotating torque (N·m)	1,600	1,800	2,600
Max. Horizontal reaction force (N)	1,200	1,300	1,300
Max. Vertical rotating torque (N·m)	1,900	2,200	3,400
Max. Vertical rotating torque (N)	6,600	6,000	7,800

The plate for the Manipulator mounting face should be 30 mm thick or more and made of steel to reduce vibration. The surface roughness of the steel plate should be 25 μm or less.

The base table must be secured on the floor to prevent it from moving.

The Manipulator installation surface should have a flatness of 0.5 mm or less and an inclination of 0.5 ° or less. If the flatness of the installation surface is improper, the base may be damaged or the robot may not fully show its performance.

When using a leveler to adjust the height of the base table, use a screw with M16 diameter or more.

Connector

If you are passing cables through the holes on the base table, see the figures below.
[unit : mm]

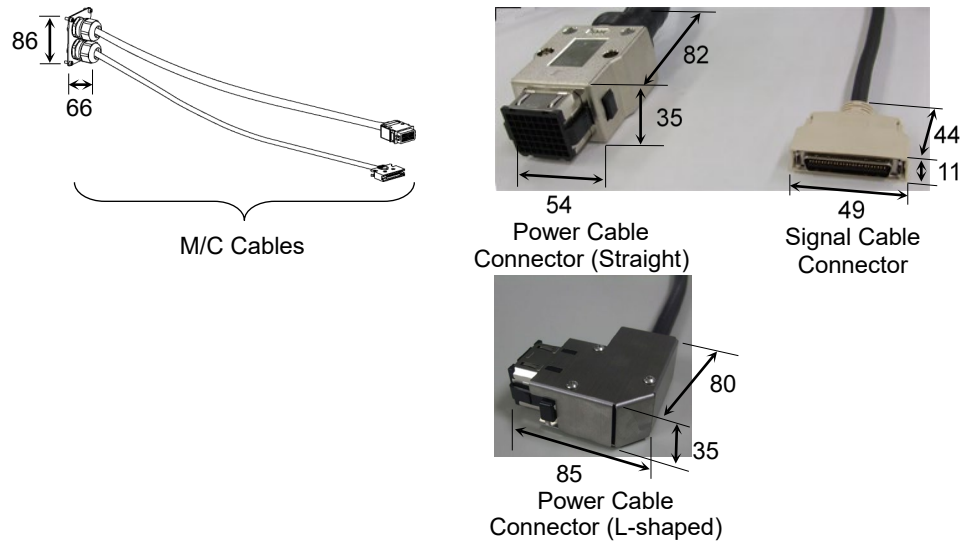

Do not remove the M/C cables from the Manipulator.





For environmental conditions regarding space when placing the Controller on the base table, refer to the Robot Controller manual.

When using the Manipulator in the cleanroom, follow the steps below before the installation.

- (1) Unpack the Manipulator outside of the cleanroom.
- (2) Secure the Manipulator to delivery equipment such as a pallet with bolts so that the Manipulator does not fall over.
- (3) Wipe off the dust on the Manipulator with a little alcohol or distilled water on a lint-free cloth.
- (4) Transport the Manipulator into the cleanroom.
- (5) Secure the Manipulator to the base table.

3.5 Connecting the Cables

 WARNING	<ul style="list-style-type: none"> ■ Before performing any replacement procedure, turn OFF the Controller and related equipment, and then disconnect the power plug from the power source. Performing any replacement procedure with the power ON is extremely hazardous and may result in electric shock and/or malfunction of the robot system. ■ Be sure to connect the AC power cable to a power receptacle. DO NOT connect it directly to a factory power source. To shut off power to the robot system, disconnect the power plug from the power source. Performing any work while connecting the AC power cable to a factory power source is extremely hazardous and may result in electric shock and/or malfunction of the robot system. ■ Be sure to connect the cables properly. Do not allow unnecessary strain on the cables. (Do not put heavy objects on the cables. Do not bend or pull the cables forcibly.) The unnecessary strain on the cables may result in damage to the cables, disconnection, and/or contact failure. Damaged cables, disconnection, or contact failure is extremely hazardous and may result in electric shock and/or improper function of the robot system. ■ Before wiring, turn OFF the Controller and related equipment, and then pull up a warning sign (e.g. DO NOT TURN ON THE POWER.). Wiring with the power ON is extremely hazardous and may result in electric shock and/or malfunction of the robot system. ■ Grounding the Manipulator is done by connecting with the Controller. However, it is recommended to use the grounding hole on the base to ground directly for more secure grounding. If the ground wire is improperly connected to ground, it may result in the fire or electric shock. ■ When connecting / replacing the brake release unit or the external short connector, turn OFF the power to the Controller and the brake release unit. Inserting and removing the connector while the power is ON may result in electrical shock.
--	--

 CAUTION	<ul style="list-style-type: none"> ■ When connecting the Manipulator and the Controller, make sure that the serial numbers on each equipment match. Improper connection between the Manipulator and Controller may not only cause improper function of the robot system but also safety problems. The connection method varies with the Controller used. For details on the connection, refer to the Robot Controller manual. ■ Only authorized or certified personnel should be allowed to perform wiring. Wiring by unauthorized or uncertified personnel may result in bodily injury and/or malfunction of the robot system. ■ If the Manipulator is operated without connecting the brake release unit or the external short connector, the brakes cannot be released and it may cause damage on them. After using the brake release unit, be sure to connect the external short connector to the Manipulator, or check connection of the connector for the brake release unit.
--	--

Cleanroom-model Manipulator

For the Cleanroom-model, an exhaust system is necessary. For details, refer to “Appendix A: Specifications Table”.

Protection-model Manipulator

For the Protection-model, also make sure to follow the following precautions.

 CAUTION	<ul style="list-style-type: none"> ■ When operating the Manipulator under special environmental conditions (adverse conditions with dust and oily smoke), do not place the Controller in the same condition since the Controller does not comply with IP67. Doing so may cause equipment damage to and/or malfunction of the Controller. ■ After using the brake release unit, be sure to reconnect the external short connector to the Manipulator. The brake release unit is not certified with the protection rating (IP67).
--	---

M/C Cable Connection method

Connect the power connector and the signal connector of the M/C cables to the Controller.

Grounding

 WARNING	<ul style="list-style-type: none"> ■ Ground resistance must be 100 Ω or less. Improper ground resistance may result in fire and/or electric shock. ■ Do not use the ground line for the Manipulator in common with other ground lines or grounding electrodes for other electric power, motor power, welding devices, etc. Using the ground line for the Manipulator in common with other ground lines or grounding electrodes may result in electric shock and/or malfunction of the robot system. ■ When using metal ducts, metallic conduits, or distributing racks for cable, ground in accordance with national and local electric equipment technical standards. Grounding that does not meet the standards may result in electric shock and/or malfunction of the robot system.
--	---

Follow local regulations for grounding. It is recommended that the core size of the grounding wire be 5.5 mm² or more.

Directly connect the ground line to the Manipulator as shown in the figure below.

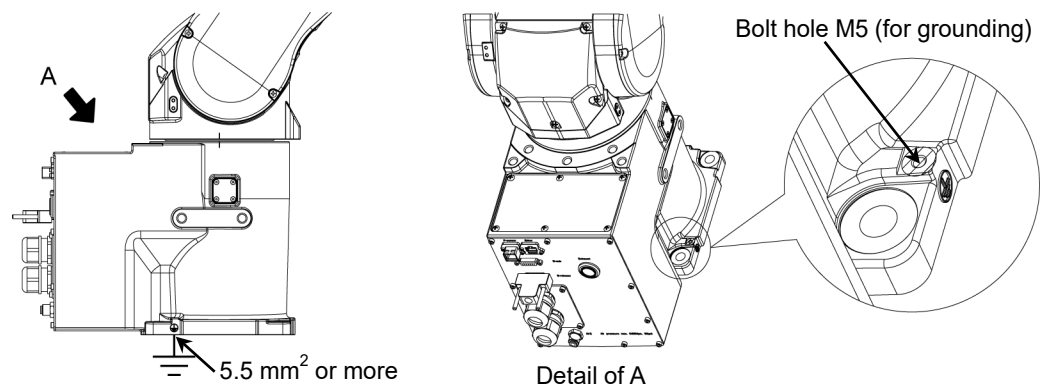

3.6 User Wires and Pneumatic Tubes

 CAUTION	<p>■ Only authorized or certified personnel should be allowed to perform wiring. Wiring by unauthorized or uncertified personnel may result in bodily injury and/or malfunction of the robot system.</p>
---	--

User electrical wires and pneumatic tubes are contained in the cable unit.

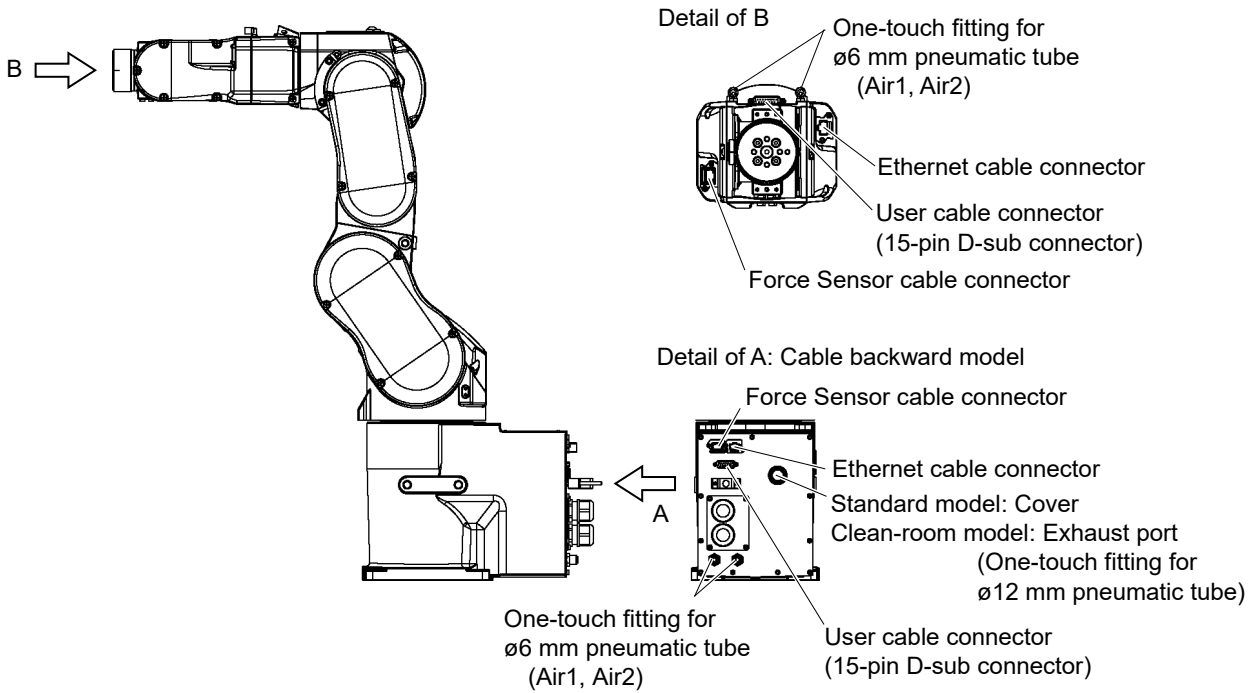

(Figure: C8-A701* (C8))

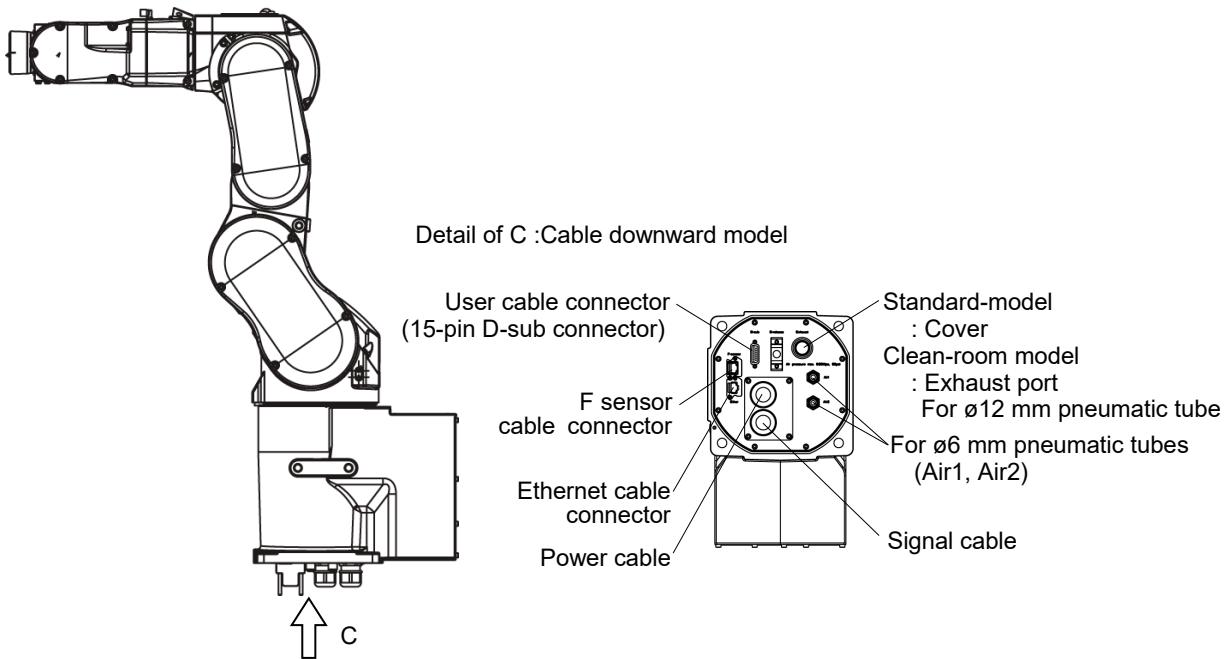

(Figure: C8-A701*B (C8))

Electrical wires

Specifications of the user wires D-sub 15-pin

Rated Voltage	Allowable Current	Wires	Nominal Sectional Area	Note
AC/DC30 V	1 A	15	0.106 mm ²	Shielded

Pins with the same number, indicated on the connectors on both ends of the cables, are connected.

Attached connector for the user wires (standard-model, cleanroom-model)

		Maker	Standard	
15 pin	Connector	JAE	DA-15PF-N	(Solder type)
	Clamp Hood	HRS	HDA-CTH(4-40)(10)	(Connector setscrew: #4-40 UNC)

Two parts are attached for each.

Attached connector for the user wires (protection-model)

		Maker	Standard	
15 pin	Connector	HARTING	09 67 015 5615	(Solder type)
	Clamp Hood	HARTING	09 67 015 0538	(Connector setscrew: #4-40 UNC)

Two parts are attached for each.

8 pin (RJ45) Cat.5e or equivalent

For the standard and cleanroom model Manipulators, commercially available Ethernet cables can be used.

For the protection-model, use the following optional part.

User connector kit (IP67 waterproof, for RJ45, 2 pcs)

For details, refer to “6. Option”.

Other

The 6-pin cable for the F sensor option is included.

Pneumatic tubes		
Max. Usable Pneumatic Pressure	Pneumatic Tubes	Outer Diameter × Inner Diameter
0.59 MPa (6 kgf/cm ² : 86 psi)	2	ø6 mm × ø4 mm

Standard model, Cleanroom model

The elbow fitting is attached on the Arm #4 at the time of shipment. The part can be replaced with the straight fitting (accessory) according to application.

Protection model

The plugs are installed on the Arm #4 and the base. To use the air tubes, remove the plugs and install the fittings (accessory) on the Arm #4.

Screw hole size for installing the Arm #4 fitting: M6

For the protection-model, see the following precautions as well.

 CAUTION	<ul style="list-style-type: none"> ■ Be sure to use IP67 compliant wires and tubes when using the Manipulator under special environmental conditions (adverse condition with dust and oily smoke). Using unprotected wires and tubes may cause equipment damage to and/or malfunction of the Manipulator as proper operation of the Manipulator under the conditions is no more guaranteed. ■ Be sure to attach the cap or plug (attached at the time of shipment) on the user cable connector when not using the connector. Using the Manipulator without the cap or plug may cause equipment damage to and/or malfunction of the Manipulator as dust or oily smoke gets into the connector.
---	---

3.7 Checking the Basic orientation

After installing the Manipulator and setup the operating environment, check if it moves to the basic position properly.

Follow the steps below to set the basic orientation of the Manipulator shown below as the origin position.

- (1) Start Epson RC+.
Double click the [Epson RC+] icon on the desktop.
- (2) Open the command window.
Epson RC+ menu-[Tools]-[Command Window]
- (3) Execute the following command in [Command Window].

```
>Motor On  
>Go Pulse (0,0,0,0,0,0)
```

If the Manipulator cannot be in the basic orientation shown below, please contact the supplier of your region.

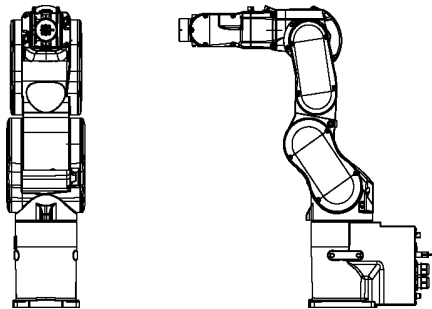

Basic orientation (0 pulse position)

(Figure: C8-A701** (C8))

4. End Effectors

4.1 Attaching an End Effector

Create an end effector for your Manipulator. For details of attaching an end effector, refer to “*Hand Function Manual*”

Flange dimensions of the wrist attached to the end of Arm #6 is as below.

 CAUTION	<ul style="list-style-type: none"> ■ If you use an end effector equipped with a gripper or chuck, connect wires and/or pneumatic tubes properly so that the gripper does not release the work piece when the power to the robot system is turned OFF. Improper connection of the wires and/or pneumatic tubes may damage the robot system and/or work piece as the work piece is released when the Emergency Stop switch is pressed. I/O outputs are configured at the factory so that they are automatically shut off (0) by power disconnection, the Emergency Stop switch, or the safety features of the robot system. However, the I/O set in the hand function does not turn off (0) when the Reset command is executed or in emergency stop.
---	---

Wrist Flange

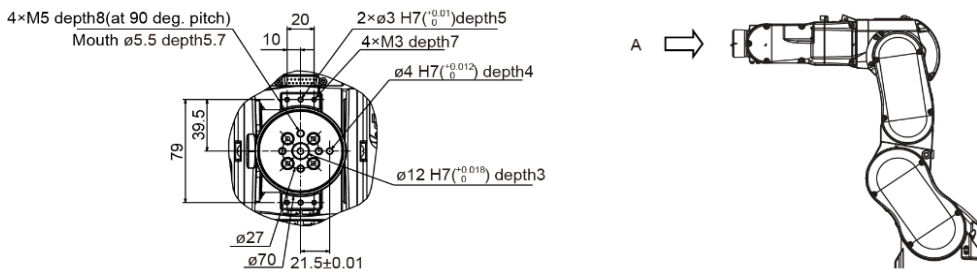

Details from A view

Arm #6

Attach an end effector to the end of the Arm #6 using the M5 bolts.

Layouts

When you operate the Manipulator with an end effector, the end effector may interfere with the Manipulator body depending on the outer diameter of the end effector, the size of the work piece, or the position of the arms. When designing your system layout, pay close attention to the interference area of the end effector.

Compatibility with ISO flange:

To install the end effector whose mounting dimensions are designed for the ISO flange, we provide the optional C8 ISO flange (J6). For details, refer to “6. Options”.

4.2 Attaching Camera and Air Valves

Decks are equipped to Arms #3 and #5 to enable the easy installation of air valve.

To mount the camera, the camera plate unit is necessary.

We provide the optional Camera Plate Unit. For details, refer to “6. Options”.

C8-A701*** (C8)

C8-A901*** (C8L)

[Unit: mm]

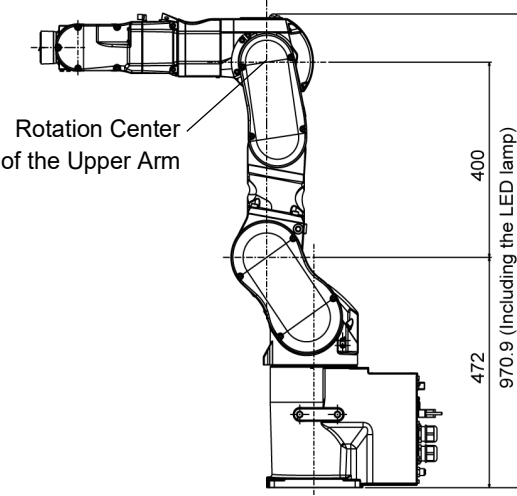
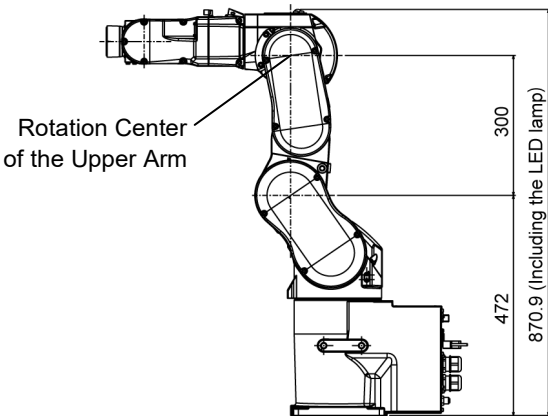
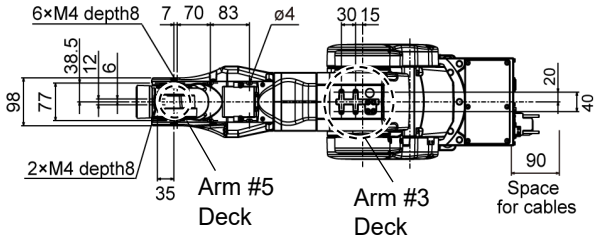
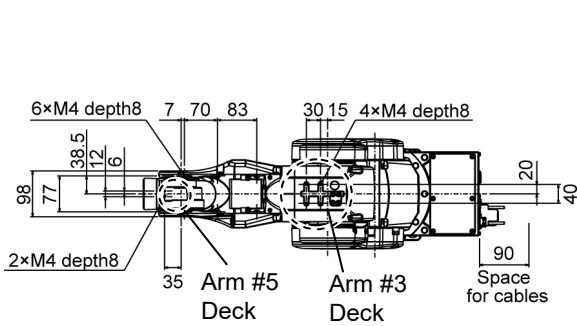

C8-A1401*** (C8XL)

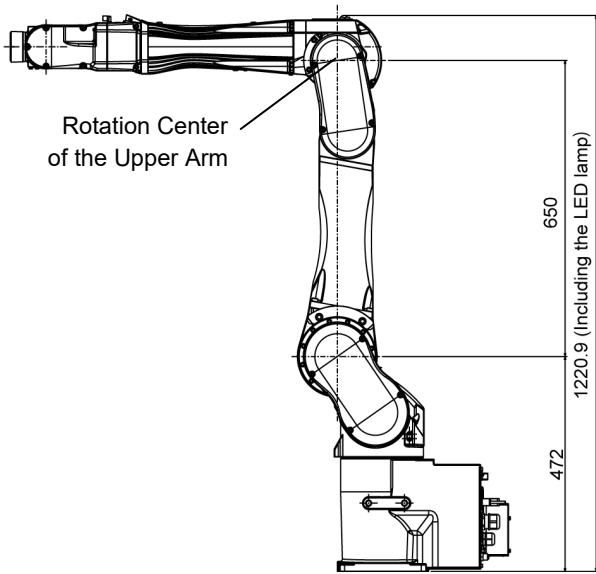
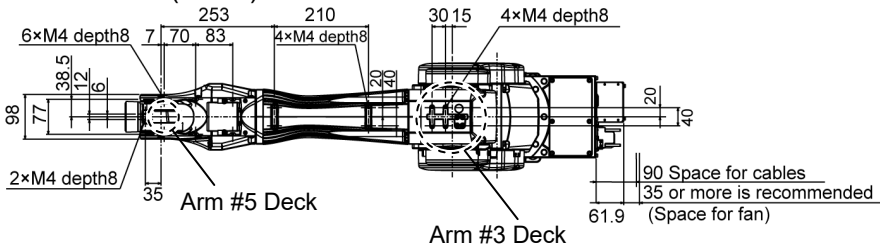

4.3 WEIGHT and INERTIA Settings

The WEIGHT and INERTIA (inertia moment and eccentricity) commands are for setting the load parameters of the Manipulator. These settings optimize the Manipulator motion.

WEIGHT Setting

The WEIGHT command is for setting the load weight. The more the load weight increases, the more the speed and acceleration/deceleration are reduced.

INERTIA Setting

The INERTIA command is for setting the inertia moment and the eccentricity of the load. The more the inertia moment increases, the more the acceleration and deceleration of the Arm #6 are reduced. The more the eccentricity increases, the more the acceleration and deceleration for the Manipulator movement are reduced.

To ensure optimum Manipulator performance, make sure that the load (weight of the end effector and work piece) and inertia moment of the load are within the maximum rating for the Manipulator, and that Arm #6 does not become eccentric.

If the load or the inertia moment exceeds the ratings or if the load becomes eccentric, follow the steps in “4.3.1 WEIGHT Setting” and “4.3.2 INERTIA Setting”, to set parameters.

Setting parameters makes the operation of the Manipulator optimal, reduces vibration to shorten the operating time, and improves the capacity for larger loads. In addition, it reduces persistent vibration produced when the inertia moment of the end effector and work piece is bigger.

You can also set by following “Weight, Inertia, and Eccentricity/offset Measurement Utility”. The following manual describes the details.

Epson RC+ User’s Guide

6.18.12 Weight, Inertia, and Eccentricity/offset Measurement Utility

The allowable load for C8 series Manipulators is 8 kg at the maximum.

Due to the limitations of the moment and inertia moment shown in the table below, the load (end effector weight + work piece weight) should also meet these conditions.

Allowable Load

Joint	Allowable Moment	GD ² /4 Allowable Moment of Inertia
#4	16.6 N·m (1.69 kgf·m)	0.47 kg·m ²
#5	16.6 N·m (1.69 kgf·m)	0.47 kg·m ²
#6	9.4 N·m (0.96 kgf·m)	0.15 kg·m ²

Moment

The moment indicates amount of torque applied on the joint in order to support the gravity on the load (end effector + work piece).

The moment increases as weight of the load and amount of eccentricity increase. As this also increases the load applied on the joint, make sure to keep the moment within the allowable value.

Inertia moment

The inertia moment indicates how difficult the load (end effector + work piece) to rotate when the Manipulator joint starts to rotate (amount of inertia). The inertia moment increases as weight of the load and amount of eccentricity increase. As this also increase the load applied on the joint, make sure to keep the inertia moment within the allowable value.

The moment M (Nm) and inertia moment I (kgm^2) when the volume of the load (end effector + work piece) is small can be obtained by the following formula.

$$M \text{ (Nm)} = m \text{ (kg)} \times L \text{ (m)} \times g \text{ (m/s}^2\text{)}$$

$$I \text{ (kgm}^2\text{)} = m \text{ (kg)} \times L^2 \text{ (m)}$$

m : Weight of load (kg)

L : Eccentric quantity of load (m)

g : Gravitational acceleration (m/s^2)

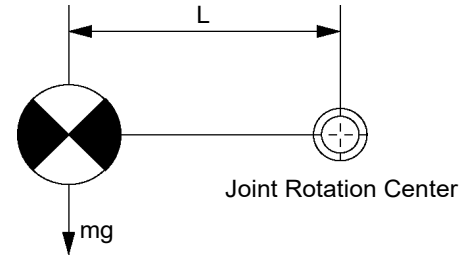

The figure below shows distribution of the center of gravity when the volume of the load (end effector + work piece) is small.

Design the end effector so that the center of gravity is within the allowable moment.

If the volume of the load is large, calculate the moment and inertia moment by referring to “4.3.2 INERTIA setting” - “Calculating the Inertia Moment”.

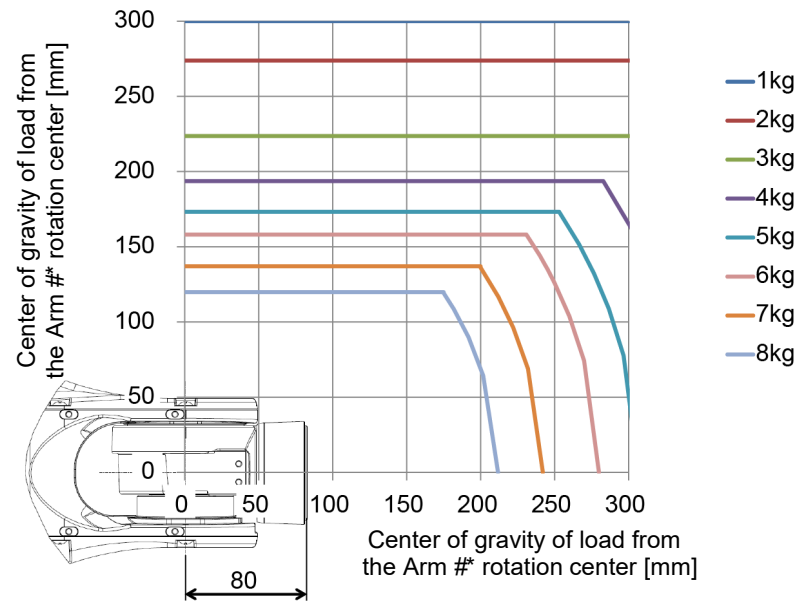

Max. Eccentric Quantity of Load

(Distance between the joint rotation center and the load’s center of gravity)

Joint	1 kg	2 kg	3 kg	4 kg	5 kg	6 kg	7 kg	8 kg
#4	300 mm	300 mm	300 mm	300 mm	300 mm	280 mm	242 mm	212 mm
#5	300 mm	300 mm	300 mm	300 mm	300 mm	280 mm	242 mm	212 mm
#6	300 mm	274 mm	224 mm	194 mm	173 mm	158 mm	137 mm	120 mm

When calculating the critical dimension of the load using the allowable moment and inertia moment, the calculated value represents a distance from the Arm #6 rotation center, not the distance from the flange. To calculate the distance from the flange to the load's center of gravity, subtract the distance from the center of the Arm #5 rotation center to the flange (=80 mm) as shown in the example below.

Example: Calculation of the critical dimension of the load (a) when the load is 8 kg.

Center of gravity by the allowable moment control:

$$16.6 \text{ N}\cdot\text{m}/(8 \text{ kg}\times 9.8 \text{ m/s}^2) = 0.212 \text{ m} = 212 \text{ mm}$$

Center of gravity by the allowable inertia moment control:

$$(0.47 \text{ kgm}^2/8 \text{ kg})^{1/2} = 0.242 \text{ m} = 242 \text{ mm}$$

Due to the allowable moment control, center of gravity for the load limit is 212 mm from the Arm #5 rotation center.

Distance from the flange to the center of gravity for the load limit

$$a = 212 \text{ mm} - 80 \text{ mm} = 132 \text{ mm}$$

Critical Dimension of Load

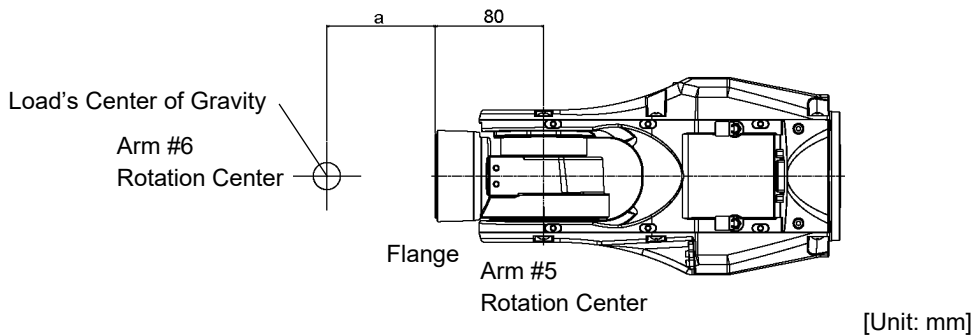

4.3.1 WEIGHT setting

 CAUTION	<ul style="list-style-type: none"> ■ Set the total weight of the end effector and the work piece smaller than the maximum payload. The C8 series Manipulators can operate without limitations on the condition unless and until the load exceeds this maximum payload. Always set the Weight parameters of the WEIGHT command according to the load. Setting a value that is smaller than the actual load may cause errors, excessive shock, insufficient function of the Manipulator, and/or shorten the life cycle of parts/mechanisms.
--	---

The acceptable weight capacity (end effector and work piece) for C8 series Manipulators is as follows:

Rated	Maximum
3 kg	8 kg

Change the setting of the Weight parameter according to the load. After changing the Weight parameter setting, the maximum acceleration/deceleration and speed of the robot system corresponding to the load is set automatically.

Epson
RC+

Setting method of Weight parameters

Select [Tools]-[Robot Manager]-[Weight] panel and set the value in [Weight:].
You may also execute the Weight command from [Command Window].

Load on the Manipulator
Mounting location of the load

C8-A701*** (C8)
Load on the fore end of Arm #6

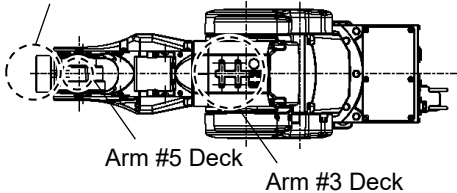

C8-A901*** (C8L)
Load on the fore end of Arm #6

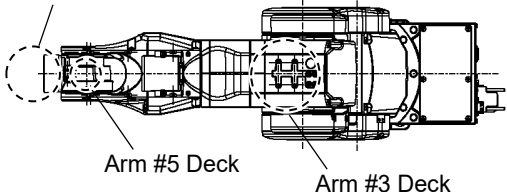

C8-A1401*** (C8XL)
Load on the fore end of Arm #6

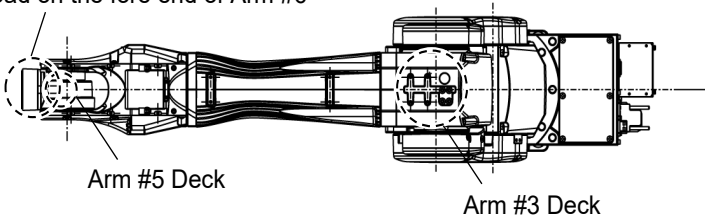

Details of the deck

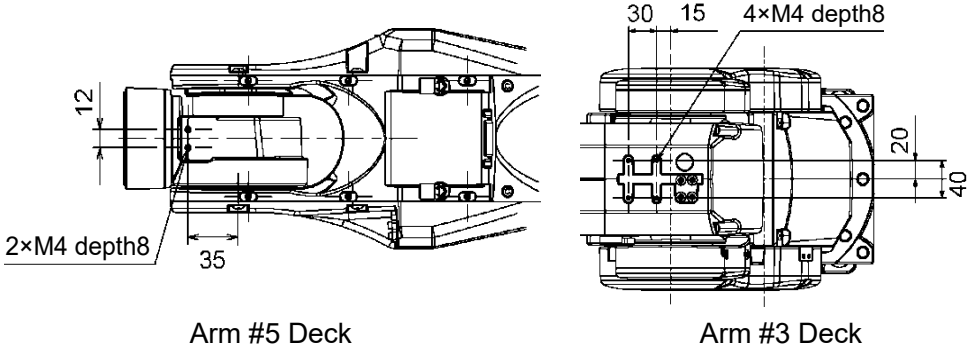

[Unit: mm]

When you attach the equipment to the decks on the upper arm, convert its weight into equivalent weight assuming that the equipment is attached to the end of the Arm #6. Then, this equivalent weight added to the load will be a Weight parameter.

Calculate the Weight parameter by using the formula below and enter the value.

Weight Parameter Formula

Weight parameter = $M_w + W_a + W_b$

M_w : Load on the fore end of Arm #6 (kg)
 W_a : Equivalent weight of the Arm #3 deck (kg)
 W_b : Equivalent weight of the Arm #5 deck (kg)

$W_a = M_a (L_a)^2 / (L)^2$
 $W_b = M_b (L_b)^2 / (L)^2$

M_a : Weight of the air valve on the Arm #3 deck
 M_b : Weight of the camera on the Arm #5 deck
 L : Length of the upper arm (315 mm)
 L_a : Distance between the Joint #3 and the center of gravity of the air valve on the Arm #3 deck (mm)
 L_b : Distance between the Joint #3 and the center of gravity of the camera on the Arm #5 deck (mm)

<Example> The fore end of the Arm #6 is 730 mm (L) away from the Joint #3 of C8-A1401*** (C8XL).

Load on the fore-end of Arm #6 is 5 kg (M_w).

Load on the Arm #3 deck is 1.5 kg (M_a).

The deck is 0 mm (L_a) away from Joint #3.

Load on the Arm #5 deck is 1.0 kg (M_b).

The deck is 690 mm (L_b) away from the Joint #3.

$$W_a = 1.5 \times 0^2 / 730^2 = 0$$

$$W_b = 1.0 \times 690^2 / 730^2 = 0.89 \rightarrow 0.9 \text{ (round up)}$$

$$M_w + W_a + W_b = 5 + 0 + 0.9 = 5.9$$

Enter “5.9” for the Weight parameter.

Automatic speed setting by Weight parameter

The percentages in the graphs are based on the speed at rated weight (3 kg) as 100%.

C8-A701***(C8)

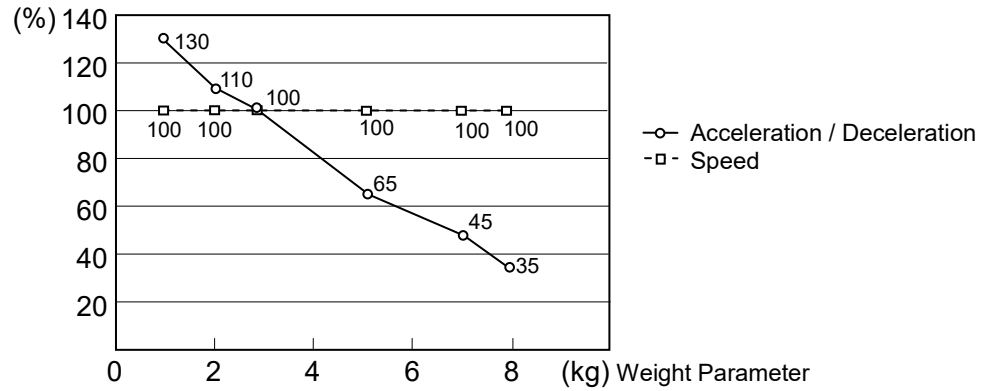

C8-A901***(C8L)

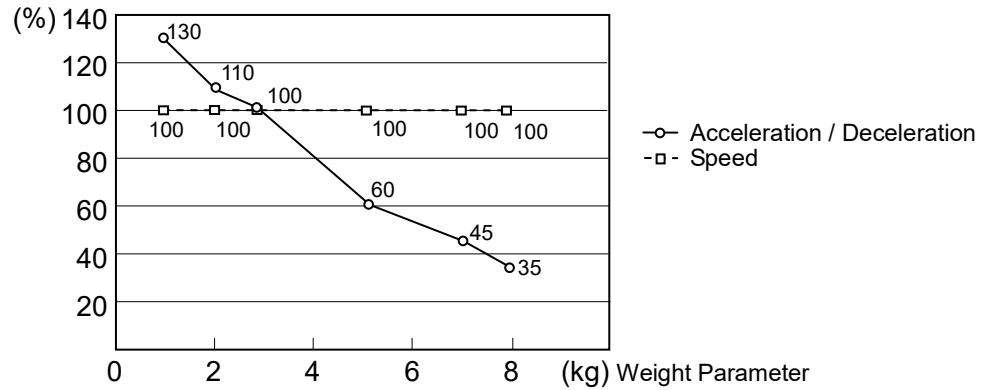

C8-A1401***(C8XL)

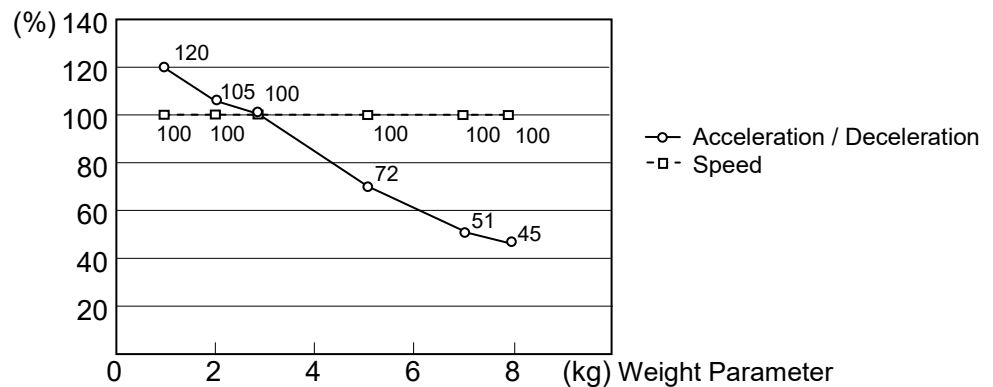

NOTE Maximum AccelS setting value varies depending on Weight setting value. For more details, refer to “Appendix A: Specifications Table”.

4.3.2 INERTIA setting

Inertia Moment and the INERTIA Setting

The inertia moment is defined as “the ratio of the torque applied to a rigid body and its resistance to motion”. This value is typically referred to as “the moment of inertia”, “inertia”, or “GD²”. When the Manipulator operates with objects such as an end effector attached to the Arm #6, the moment of inertia of load must be considered.

 CAUTION	<ul style="list-style-type: none"> ■ The inertia moment of the load (weight of the end effector and work piece) must be 0.15 kg·m² or less. The C8 series Manipulators are not designed to work with inertia moment exceeding 0.15 kg·m². Always set the inertia moment (INERTIA) parameter according to the inertia moment. Setting a value that is smaller than the actual inertia moment may cause errors, excessive shock, insufficient function of the Manipulator, and/or shorten the life of parts/mechanisms.
---	--

The acceptable inertia moment of load for C8 series Manipulators is 0.03 kg·m² nominal rating and 0.15 kg·m² maximum. Change the setting of the inertia moment according to the inertia moment of the load using the INERTIA command. After the setting has been changed, the maximum acceleration/deceleration speed of Arm #6 responding to “inertia moment” is set automatically.

Inertia moment of load on Arm #6

The inertia moment of the load (weight of the end effector and work piece) on the Arm #6 can be set by the “inertia moment (INERTIA)” parameter of the INERTIA command.

Epson
RC+

Select [Tools]–[Robot Manager]–[Inertia] panel and enter the value in [Load inertia:]. You may also execute the Inertia command from [Command Window].

Eccentric Quantity and the INERTIA Setting



- The eccentric quantity of the load (weight of the end effector and work piece) must be 300 mm or less. The C8 series Manipulators are not designed to work with eccentric quantity exceeding 300 mm. Always set the eccentric quantity parameter according to the eccentric quantity. Setting a value that is smaller than the actual eccentric quantity may cause errors, excessive shock, insufficient function of the Manipulator, and/or shorten the life cycle of parts/mechanisms.

The acceptable eccentric quantity of the load for C8 series Manipulators is 50 mm at nominal rating and 300 mm at maximum. When the eccentric quantity of the load exceeds the rating, change the setting of eccentric quantity parameter using the INERTIA command. After changing the setting, the maximum acceleration/deceleration speed of Manipulator corresponding to “eccentric quantity” is set automatically.

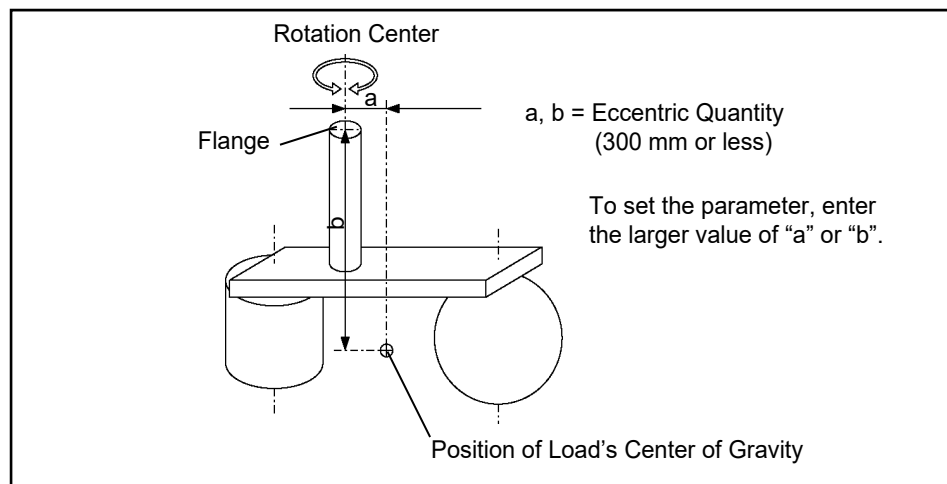

Eccentric Quantity

Eccentric quantity of load on Arm #6

The eccentric quantity of the load (weight of the end effector and work piece) on the Arm #6 can be set by the “eccentric quantity” parameter of the INERTIA command. Enter the larger value of either “a” or “b” in the figure above to [Eccentricity].

Epson
RC+

Select [Tools]–[Robot Manager]–[Inertia] panel and enter the value into [Eccentricity:]. You may also execute the Inertia command from [Command Window].

Automatic acceleration/deceleration setting by INERTIA (eccentric quantity)

Automatic setting by inertia moment setting (common to C8 series)

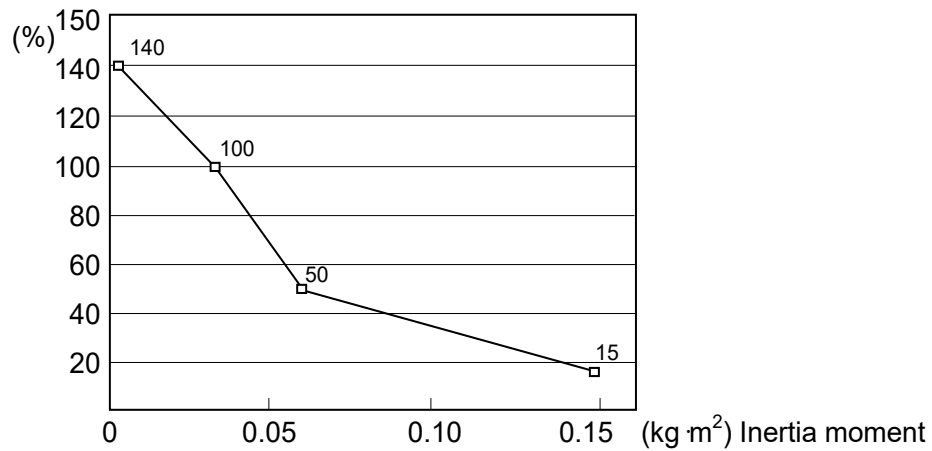

* The percentage in the graph is based on the acceleration/ deceleration at rated eccentricity (0.03 kg·m²) as 100%.

Automatic setting by eccentricity setting (common to C8 series)

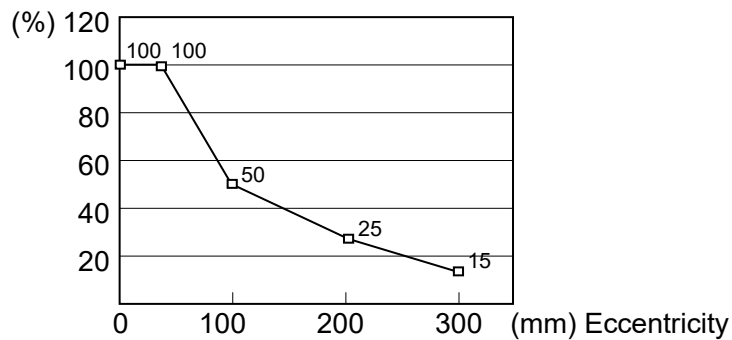

* The percentage in the graph is based on the acceleration/ deceleration at rated eccentricity (50 mm) as 100%.

Calculating the Inertia Moment

Refer to the following example formulas to calculate the inertia moment of the load (end effector with work piece).

The inertia moment of the entire load is calculated by the sum of (a), (b), and (c).

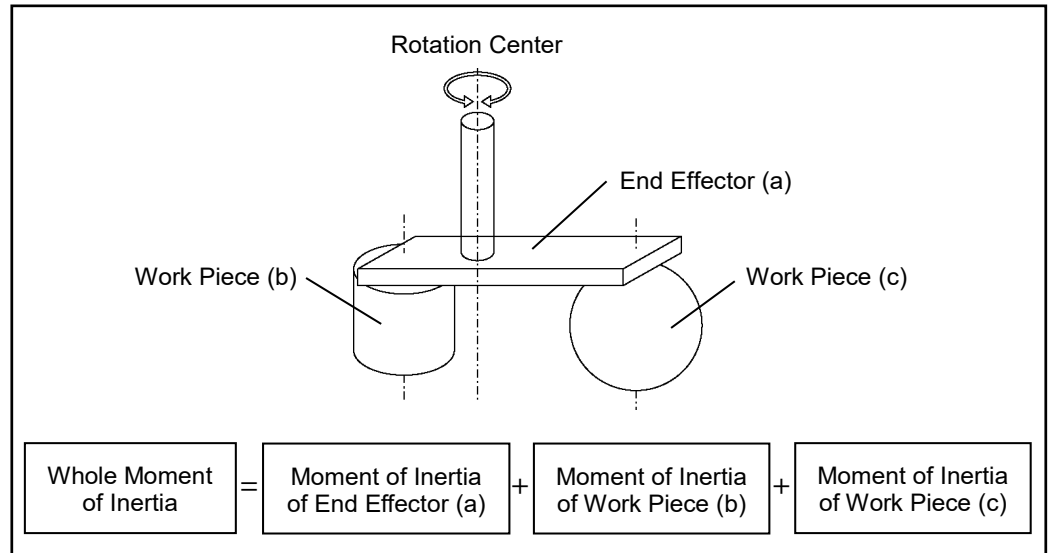

The methods for calculating the inertia moment for (a), (b), and (c) are shown in this and the next page. Figure out the whole inertia moment using the basic formulas below.

(a) Inertia moment of a rectangular parallelepiped

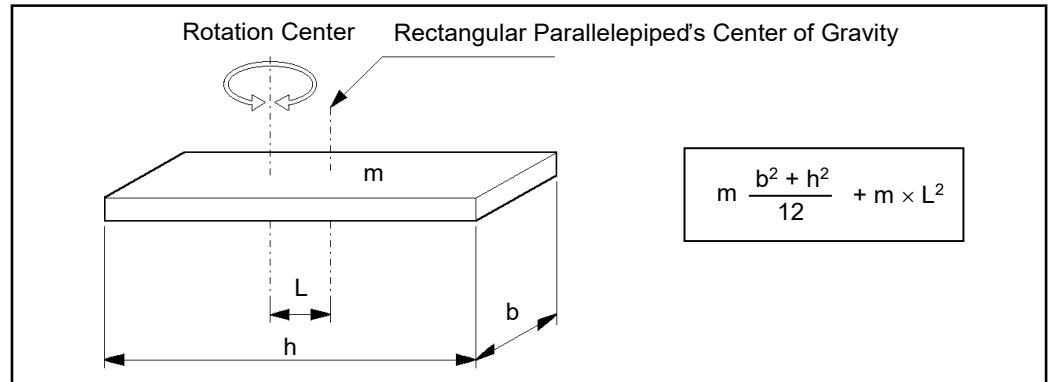

(b) Inertia moment of a cylinder

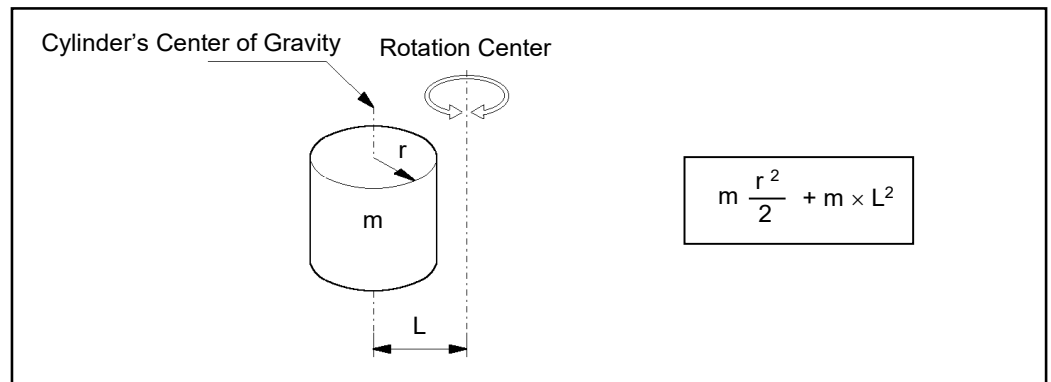

(c) Inertia moment of a sphere

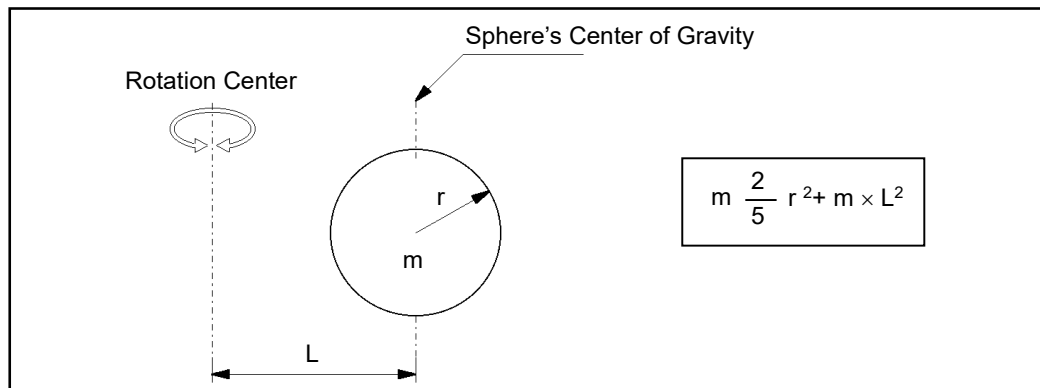

4.4 Precautions for Auto Acceleration/Deceleration

The speed and acceleration/deceleration of the Manipulator motion are automatically optimized according to the values of WEIGHT and INERTIA and the Manipulator's postures.

WEIGHT Setting

The speed and acceleration/deceleration of the Manipulator are controlled according to the load weight set by the WEIGHT command.

The more the load weight increases, the more the speed and acceleration/deceleration are reduced to prevent residual vibration.

INERTIA Setting

The acceleration/deceleration of Arm #6 are controlled according to the inertia moment set by the INERTIA command. The acceleration/deceleration of the whole Manipulator are controlled according to the eccentricity set by the INERTIA command. The more the inertia moment and eccentricity of the load increase, the more the acceleration/deceleration are reduced.

Auto Acceleration/Deceleration According to Manipulator's Posture

The acceleration/deceleration are controlled according to the Manipulator's posture. When the Manipulator extends its arms or when the movement of the Manipulator produces vibration frequently, the acceleration/deceleration are reduced.

Set appropriate values for WEIGHT and INERTIA so that the Manipulator operation is optimized.

5. Motion Range



- When limiting the motion range for safety, be sure to set by both the pulse range and mechanical stops. Failure to do so may cause serious safety problems.

The motion range is preset at the factory as describes in “2.5 Standard Motion Range”. This is the maximum motion range of the Manipulator.

Motion range is set by the following three methods:

1. Setting by pulse range (for all arms)
2. Setting by mechanical stops
3. Setting the Cartesian (rectangular) range in the X, Y coordinate system of the Manipulator

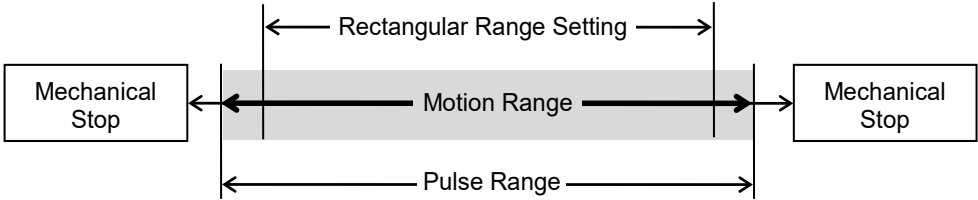

When the motion range is changed due to layout efficiency or safety, follow the descriptions in 5.1 through 5.4 to set the range.

5.1 Motion Range Setting by Pulse Range (for Each Joint)

Pulses are the basic unit of Manipulator motion. The motion range of the Manipulator is controlled by the pulse range (the lower limit and the upper limit) of each axis.

Pulse values are read from the encoder output of the servo motor.

The pulse range should be set within the mechanical stop range.



The Arm #1 and #4 do not have a mechanical stop.



Once the Manipulator receives an operating command, it checks whether the target position specified by the command is within the pulse range before operating. If the target position is out of the set pulse range, an error occurs and the Manipulator does not move.

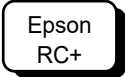

The pulse range can be set in [Tools]-[Robot manager]-[Range] panel. You may also execute the Range command from the [Command Window].

5.1.1 Max. Pulse Range of Joint #1

Pulse values in counterclockwise direction are positive (+) and values in clockwise direction are negative (-).

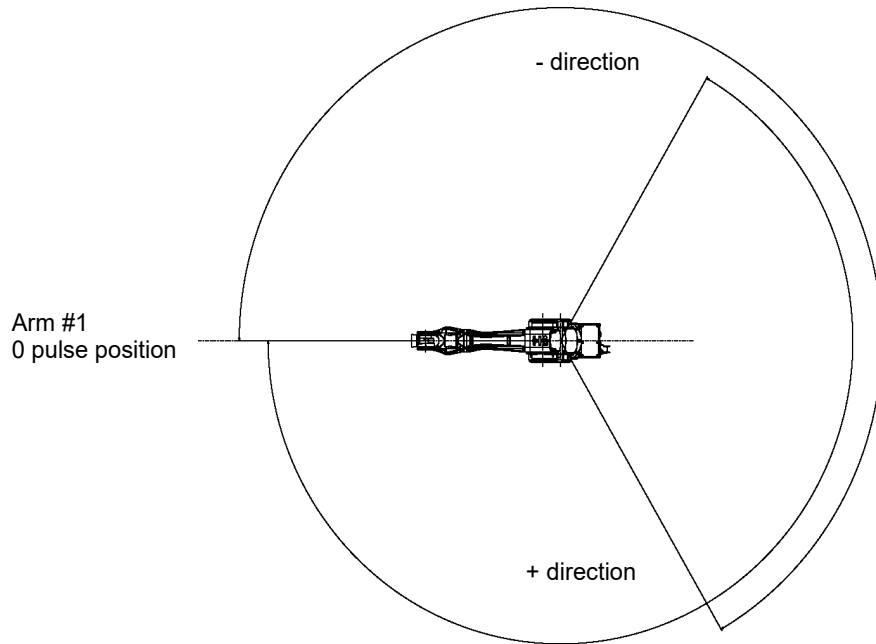

	C8-A701*** (C8)	C8-A901*** (C8L)	C8-A1401*** (C8XL)
Angle (°)	± 240		
Pulse (pulse)	± 9507090	± 10695600	± 15736800

5.1.2 Max. Pulse Range of Joint #2

Pulse values in clockwise direction are positive (+) and values in counterclockwise direction are negative (-).

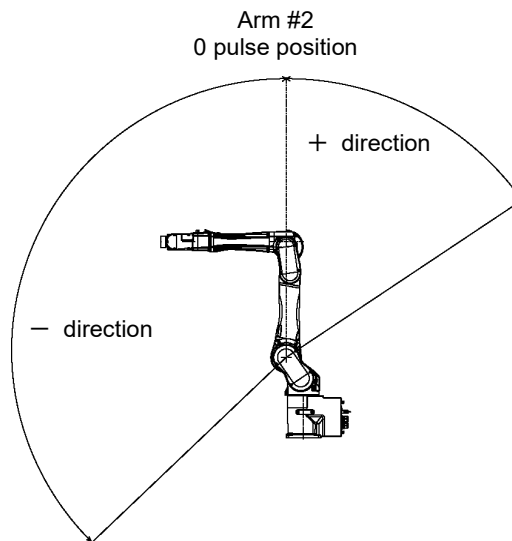

	C8-A701*** (C8)	C8-A901*** (C8L)	C8-A1401*** (C8XL)
Angle (°)	- 158 to + 65		
Pulse (pulse)	- 6245685 to + 2569428	- 6903178 to + 2839915	- 10616940 to + 4325420

5.1.3 Max. Pulse Range of Joint #3

Pulse values in clockwise direction are positive (+) and values in counterclockwise direction are negative (-).

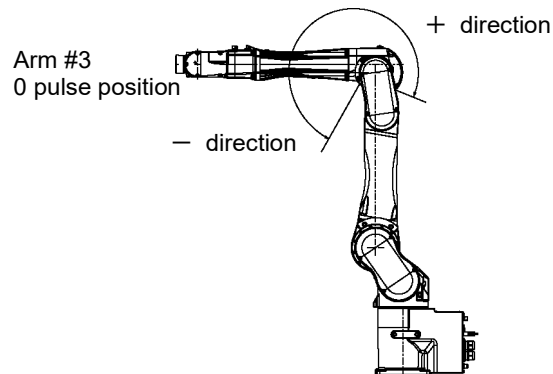

	C8-A701*** (C8)	C8-A901*** (C8L)	C8-A1401*** (C8XL)
Angle (°)	- 61 to + 202		
Pulse (pulse)	- 1776754 to + 5883677	- 2220949 to + 7354618	- 3997696 to + 13238272

5.1.4 Max. Pulse Range of Joint #4

From the angle of arm end, clockwise pulse values are positive (+) and counterclockwise pulse values are negative (-). The max. pulse range of the Arm #4 is common to C8 series Manipulators.

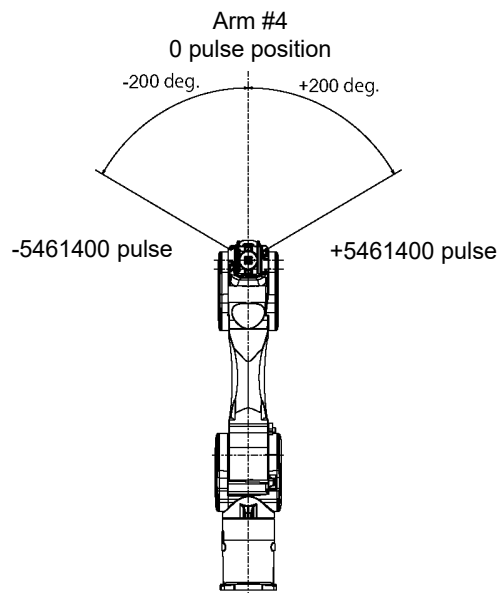

(deg.= °)

5.1.5 Max. Pulse Range of Joint #5

Pulse values in clockwise direction are positive (+) and values in counterclockwise direction are negative (-). The max. pulse range of the Arm #5 is common to C8 series Manipulators.

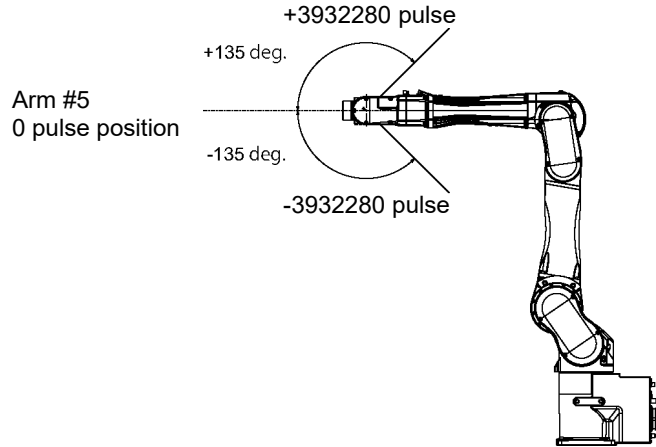

(deg.= °)

5.1.6 Max. Pulse Range of Joint #6

From the angle of arm end, clockwise pulse values are positive (+) and counterclockwise pulse values are negative (-). The max. pulse range of the Arm #6 is common to C8 series Manipulators.

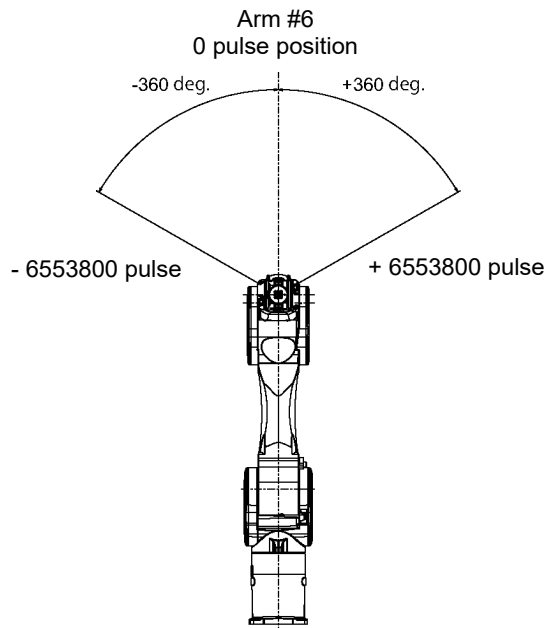

(deg.= °)

5.2 Motion Range Setting by Mechanical Stops

Using the adjustable mechanical stops physically limits the absolute area that the Manipulator can move.

Be sure to turn OFF the Manipulator in advance.

Use bolts conforming to the specified length and surface processing (ex: nickel plating) with high corrosion resistance.

Specify the pulse range again after changing the position of the mechanical stop.

For details on the pulse range setting, refer to “5.1 Motion Range Setting by Pulse Range (for All Arms)”.

Be sure to set the pulse range not to exceed the setting angles of the mechanical stop.

5.2.1 Motion Range Setting of Joint #1

Install the adjustable mechanical stop (J1) to the threaded hole corresponding to the angle you want to set.

Normally the mechanical stop is not installed.

Hexagon socket head cap bolt	M12×30×2 bolts
Strength	Equivalent to ISO898-1 property class 10.9 or 12.9
Tightening torque	42.0 ± 2.1N·m (428 ± 21 kgf·cm)

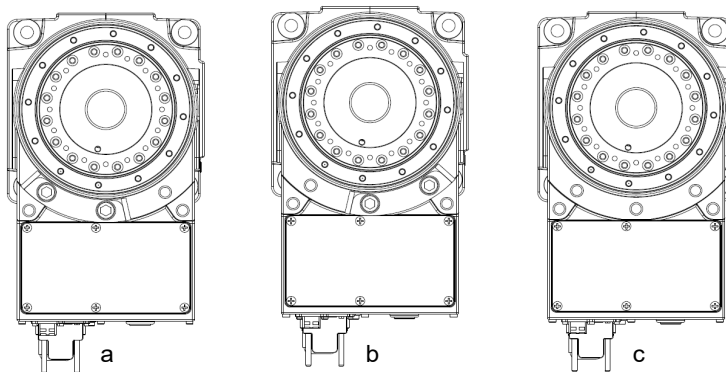

		a	b	c
Angle (°)		-145, +110	-110, +145	±240
Pulse (pulse)	C8-A701*** (C8)	-5743867 +4357416	-4357416 +5743867	±9507090
	C8-A901*** (C8L)	-6461925 +4902150	-4902150 +6461925	±10695600
	C8-A1401*** (C8XL)	-9507650 +7212700	-7212700 +9507650	±15736800
Adjustable mechanical stop (J1)		Applied	Applied	Not applied (standard)

5.2.2 Motion Range Setting of Joint #2

C8-A701*** (C8), C8-A901*** (C8L)

Remove the mechanical stop installed as standard and install the adjustable mechanical stop (C8/C8L_J2). (Joint #2 standard motion range -158 to +65°)

Hexagon socket head cap bolt M10×35×1 bolt
 Strength Equivalent to ISO898-1 property class 10.9 or 12.9
 Tightening torque 32.0 ± 1.6 N·m (326 ± 16 kgf·cm)

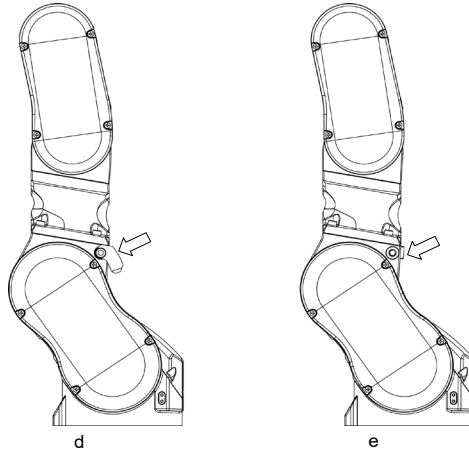

		d	e
Angle (°)		-158, +30	-158, +65
Pulse(pulse)	C8-A701*** (C8)	-6245685 +1185890	-6245685 + 2569428
	C8-A901*** (C8L)	-6903178 +1310730	-6903178 +2839915
Adjustable mechanical stop (C8/C8L_J2)		Applied	Applied (standard)

C8-A1401*** (C8XL)

Remove the mechanical stop installed as standard and install the adjustable mechanical stop (C8XL_J2). (Joint #2 standard motion range -135 to $+55^\circ$)

Hexagon socket head cap bolt M10×35×2 bolts
 Strength Equivalent to ISO898-1 property class 10.9 or 12.9
 Tightening torque $32.0 \pm 1.6 \text{ N}\cdot\text{m}$ ($326 \pm 16 \text{ kgf}\cdot\text{cm}$)

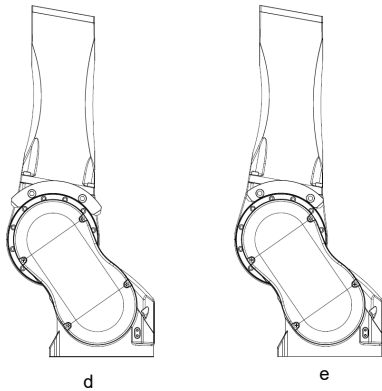

		d	e
Angle (°)		$-125, +45$	$-135, +55$
Pulse(pulse)	C8-A1401*** (C8XL)	-9830500 $+3538980$	-10616940 $+4325420$
Adjustable mechanical stop (C8XL_J2)		Applied	Applied (standard)

5.2.3 Motion Range Setting of Joint #3

Remove the mechanical stop installed as standard and install the adjustable mechanical stop (J3). (Joint #3 standard motion range -61 to $+202^\circ$)

Hexagon socket head cap bolt	M6×15×2 bolts
Strength	Equivalent to ISO898-1 property class 10.9 or 12.9
Tightening torque	13.0 ± 0.6 N·m (133 ± 6 kgf·cm)

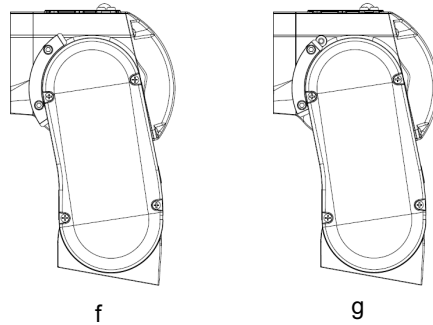

		f	g
Angle ($^\circ$)		$-51, +192$	$-61, +202$
Pulse(pulse)	C8-A701*** (C8)	-1485483 $+5592406$	-1776754 $+5883677$
	C8-A901*** (C8L)	-1856859 $+6990528$	-2220949 $+7354618$
	C8-A1401*** (C8XL)	-3342336 $+12582912$	-3997696 $+13238272$
Adjustable mechanical stop (J3)		Applied	Applied (standard)

5.3 Restriction of Manipulator Operation by Joint Angle Combination

To prevent the arms of the Manipulator from interfering each other, the Manipulator operation is restricted in the specified motion range according to the joint angle combination of the Arm #1, #2, and #3.

The Manipulator operation is restricted and the Manipulator stops when the joint angles of the Arm are within the gray areas in the following figure.

The restriction to Manipulator operation is enabled:

- During CP motion command execution
- When you attempt to execute the motion command for moving the Manipulator to a target point (or pose) in the specified motion range.

The restriction to the Manipulator operation is disabled:

- The Arms of the Manipulator momentarily go through the specified motion range during the PTP motion command execution even though the joint angles of the Arms are in the colored area of the figures above.

C8-A701***(C8)

Combination of Joints #2 and #3

-65 deg. <= J1 <= 65 deg.

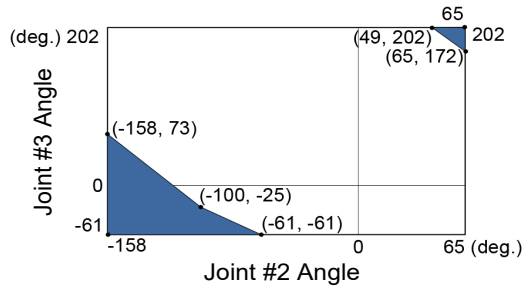

-110 deg. <= J1 < -65 deg. or 65 deg. < J1 <= 110 deg.

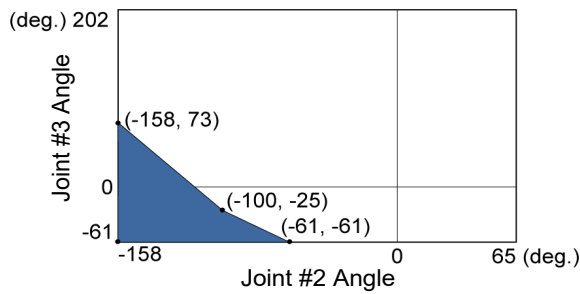

-240 deg. <= J1 < -110 deg. or 110 deg. < J1 <= 240 deg.

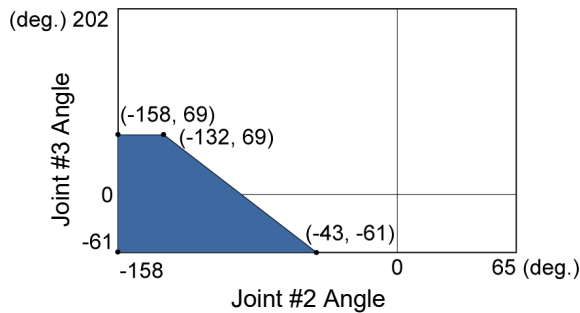

Combination of Joints #1 and #2

-240 deg. <= J1 <= -100 deg. or 100 deg. <= J1 <= 240 deg.

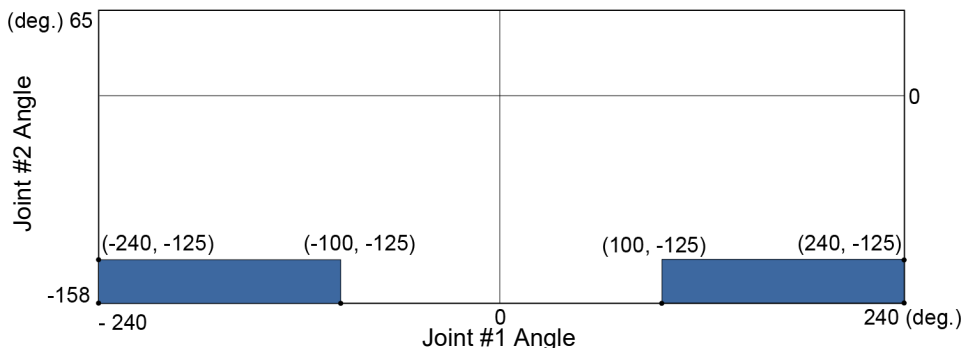

(deg = °)

C8-A901***(C8L)

Combination of Joints #2 and #3

-50 deg. <= J1 <= 50 deg.

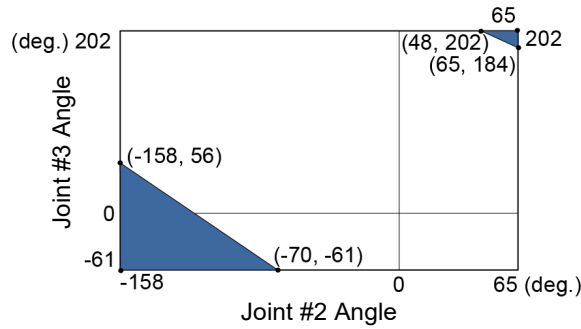

-115 deg. <= J1 < -50 deg. or 50 deg. < J1 <= 115 deg.

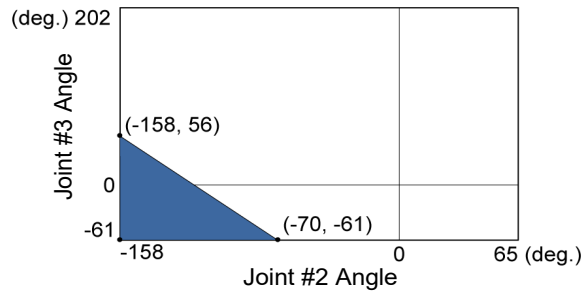

-240 deg. <= J1 < -115 deg. or 115 deg. < J1 <= 240 deg.

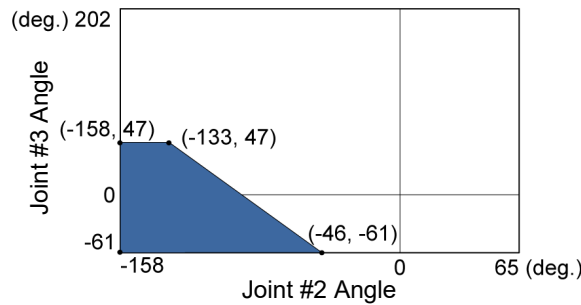

Combination of Joints #1 and #2

-240 deg. <= J1 <= -110 deg. or 110 deg. <= J1 <= 240 deg.

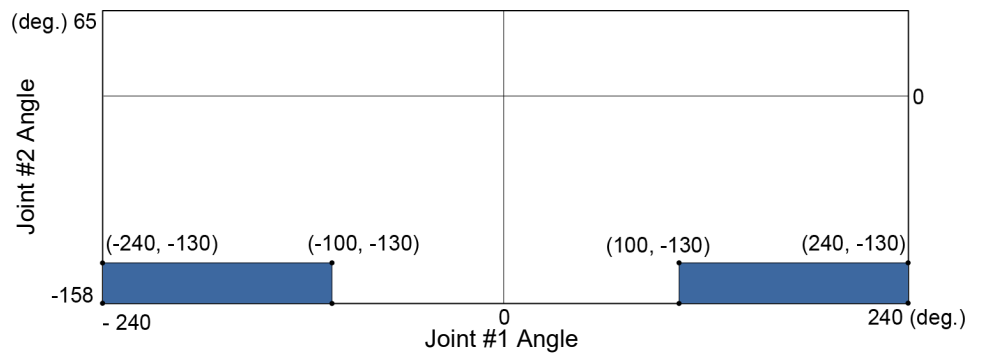

(deg = °)

C8-A1401***(C8XL)

Combination of Joints #2 and #3

-110 deg. <= J1 <= 110 deg.

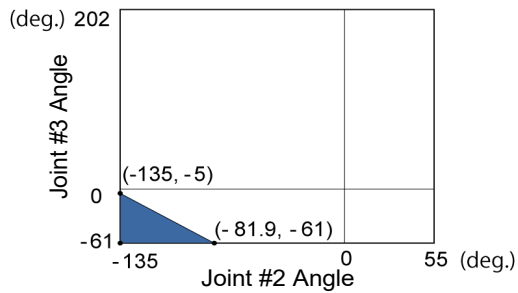

-140 deg. < J1 < -110 deg. or 110 deg. < J1 < 140 deg.

-240 deg. < J1 < -220 deg. or 220 deg. < J1 < 240 deg.

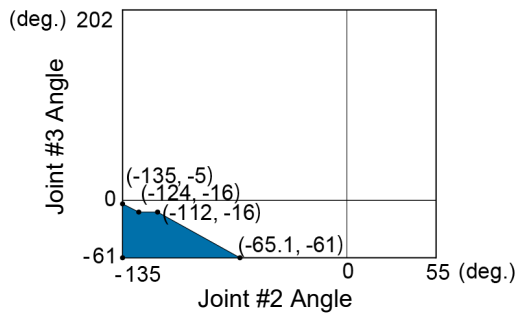

-220 deg. <= J1 <= -140 deg. or 140 deg. < J1 < 220 deg.

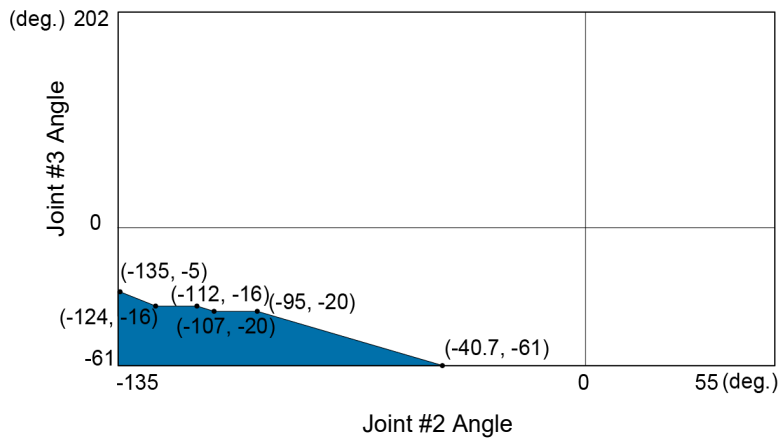

(deg = °)

5.4 Coordinate System

The origin point is where the Manipulator's installation face intersects with the rotation axis of Joint #1.

For details on the coordinate system, refer to the *Epson RC+ Users Guide manual*.

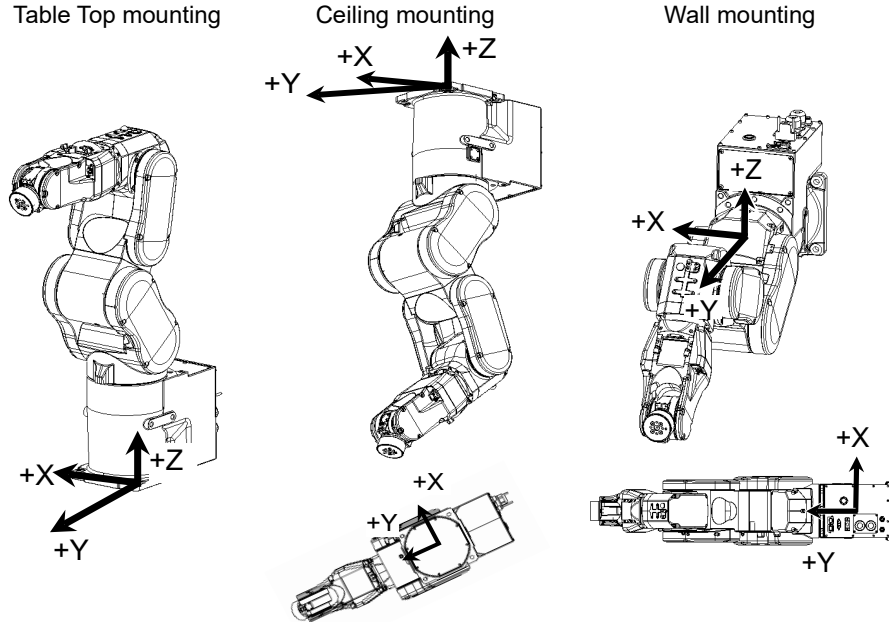

BASE setting is suitable for install the robot obliquely.

BASE setting can change a specific coordinate system of the robot and match the World coordinate system of the Jog & Teach and the coordinate system of the equipment.

For procedure of the BASE setting, refer to *SPEL+ Language Reference: BASE Command*.

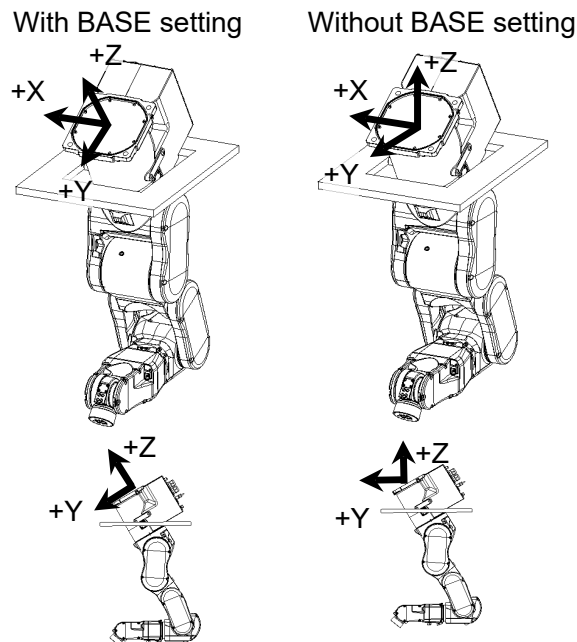

5.5 Changing the Robot

This section describes how to change the manipulator model on Epson RC+.



CAUTION

- Changing the Manipulator should be done with great caution. It initializes the robot calibration parameters (Hofs, CalPIs), additional axis information, and PG parameter data.

Before changing the robot, make sure to save the calibration data by following the procedure below.

- Select the Epson RC+ menu-[Setup]-[System Configuration].
- Select [Controller]-[Robots]-[Robot**]-[Calibration] from the tree list. Then, click [Save].

(1) Select the Epson RC+ menu-[Setup]-[System Configuration].

(2) Select [Controller]-[Robots]-[Robot**] from the tree list. (Dialog image: Epson RC+ 8.0)

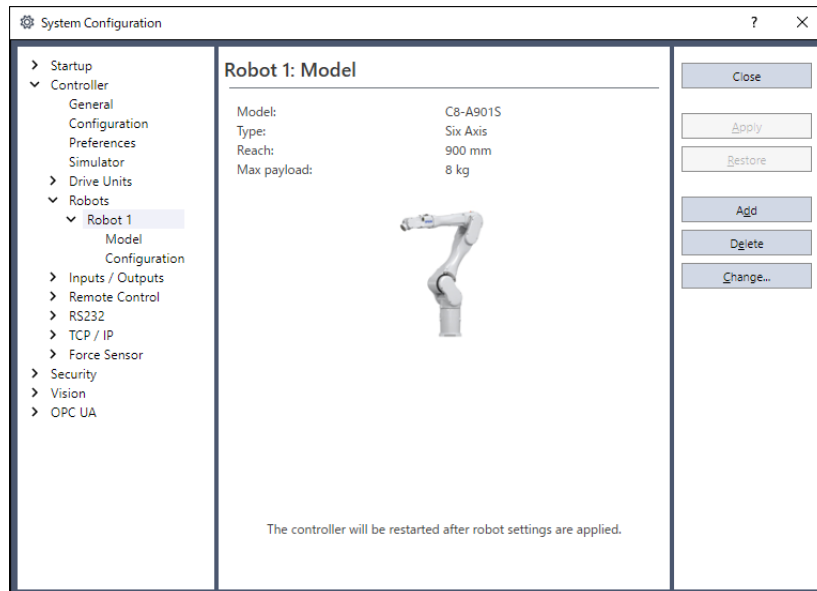

(3) Click the [Change...] button. The following dialog box will be displayed.

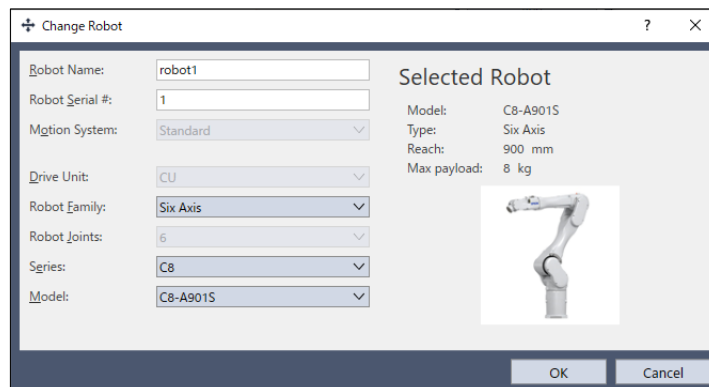

(4) Input the robot name and serial number printed on the name plate of the Manipulator. Any serial number can be entered. However, enter the number printed on the Manipulator.

- (5) Select the robot type in the [Robot type] box.
- (6) Select the series name of the Manipulator in the [Series] box.
- (7) Select the robot model in the [Model] box. Available robots will be displayed according to the format of the currently installed motor driver. When [Dry run] is used, all the Manipulators of the series selected in Step 6 will be displayed.
- (8) Click the [OK] button. The Controller will be restarted.

5.6 Setting the Cartesian (Rectangular) Range in the XY Coordinate System of the Manipulator

The Cartesian (rectangular) range in the XY coordinate system of the Manipulator is specified by the limited Manipulator operation area and the XYLIM setting.

The limited Manipulator operation area is defined so that the end effector does not interfere with the rear side of the Manipulator. The XYLIM setting that you can determine the upper and lower limits of the X and Y coordinates.

The limited Manipulator operation area and the XYLIM setting apply only to the software. Therefore, these settings do not change the physical range. The maximum physical range is based on the position of the mechanical stops.

These settings are disabled during a joint jogging operation. Therefore, be careful not to allow the end effector to collide with the Manipulator or peripheral equipment.

The method for changing the XYLIM setting varies with the software used.



Set the XYLIM setting in [Tools]-[Robot manager]-[XYZ Limits] panel. You may also execute the XYLim command from the [Command Window].

6. Options

C8 series Manipulator has the following options.

- 6.1 Brake Release Unit
- 6.2 Camera Plate Unit
- 6.3 Tool Adapter (ISO flange)
- 6.4 Adjustable Mechanical Stops
- 6.5 User Wires and Pneumatic Tubes

6.1 Brake Release Unit

With the electromagnetic brake is ON (such as in Emergency Stop status), all arms don't move.

You can move the Arms by hand using the brake release unit while the Controller power is OFF or right after unpacking.

 WARNING	<ul style="list-style-type: none"> ■ When connecting / replacing the brake release unit or the external short connector, turn OFF the power to the Controller and the brake release unit. Inserting and removing the connector while the power is ON may result in electrical shock.
--	---

 CAUTION	<ul style="list-style-type: none"> ■ Normally, release the brake of joints one by one. Take extra care if you need to release the brakes of two or more joints simultaneously. Releasing the brakes of two or more joints simultaneously may cause hands and fingers to be caught and/or equipment damage to or malfunction of the Manipulator as the arms of the Manipulator may move in unexpected directions. ■ After releasing the brake, the arm may fall by its own weight or move to the unexpected direction. Make sure to prepare a countermeasure to prevent the arm from falling and check the operation environment is safe.
--	--

Width	180 mm
Depth	150 mm
Height	87 mm
Weight (Cables are not included.)	1.7 kg
Cable to the Manipulator	2 m
M/C Short connector	For M/C power cable short-circuit

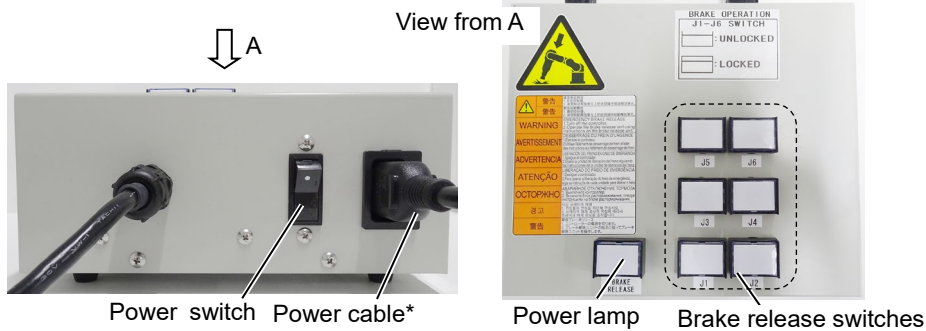

* Item you should provide

Power Cable

You must provide a power cable.

The power cable is required to meet the specifications below.

Item	Specification
(1) Plug	Comply with local safety regulation - Class I (2P+PE), AC250V, 6A or 10A Ex.: CEE Pub.7 Certified, CCC Certified, KC Certified, BS1363 Certified, PSB Certified, BIS Certified, SABS Certified - Class I (2P+PE), AC125V, 7A or 12A or, 15A etc. Ex.: UL Certified, PSE Certified, BSMI Certified
(2) Flexible cable	Comply with IEC/EN standards or local safety regulation Ex.: IEC 60227-1: General requirements IEC 60227-5: Polyvinyl chloride insulated cables of rated voltages up to and including 450/750 V - Part 5: Flexible cables (cords) EN 50525-1: General requirements EN 50525-2-11: Electric cables - Low voltage energy cables of rated voltages up to and including 450/750 V (Uo/U) - Part 2-11: Cables for general applications - Flexible cables with thermoplastic PVC insulation
(3) Appliance coupler	Comply with IEC/EN standards or local Safety regulation - IEC / EN 60320-1: Appliance couplers for household and similar general purposes - Part 1: General requirements - Standard Sheet C13: AC250V / 10A

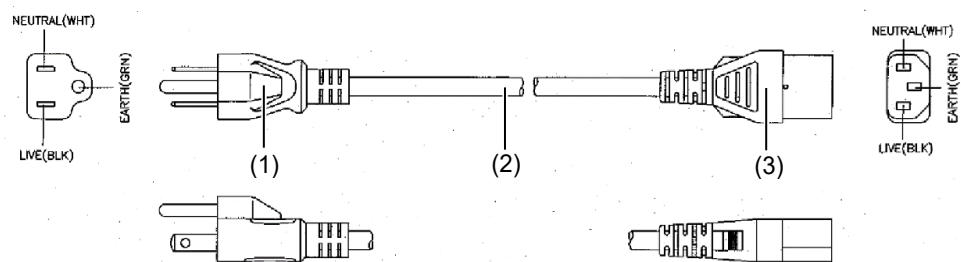

For Japan

Item	Specification
Plug	PSE Certified Class I (2P+PE), AC125V, 7A or higher
Code	PSE Certified 0.75mm ² or larger
Connector	PSE Certified IEC 60320-1 Standard Sheet C13:AC125V/10A or higher

Precautions for use



CAUTION

- If the Manipulator is operated without connecting the brake release unit and the external short connector, the brakes cannot be released and it may cause damage on them. After using the brake release unit, be sure to connect the external short connector to the Manipulator, or check connection of the connector for the brake release unit.
- Keep the external short connector. Otherwise you cannot release the brakes.
- If you turn ON the brake release unit while the brake release switch is being pressed, an unintended arm may move downward. Before turning ON the brake release unit, make sure that the brake release switch is not pressed.
- If you turn ON the brake release unit without the connector, it may lead to the short for the male pin used in the connector. Before turning ON the brake release unit, make sure that the connector is connected.

Mount the brake release unit

- (1) Turn OFF the Controller.
- (2) If the M/C power cable is not connected to the Controller:

Connect the M/C short connector,
or connect the Controller.
(Keep the Controller power OFF)

The M/C short connector can be purchased
singly.



If the M/C power cable is already connected to the Controller:

Go to the step (3).



- (3) Remove the external short connector.



NOTE If the external short connector is the type which is
shown below, remove it with a tool.



External short connector

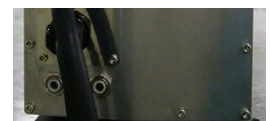

Connection cable
Connector

- (4) Connect the brake release unit to the connector of the connection cable.

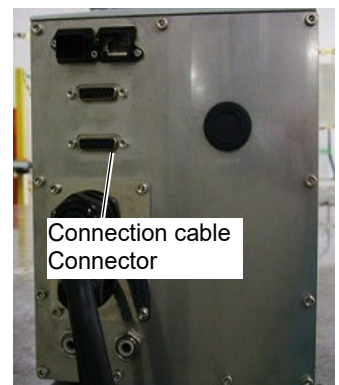

Remove the brake release unit

- (1) Turn OFF the brake release unit.
- (2) Remove the power cable of the brake release unit.
- (3) Disconnect the brake release unit from the connector of the connection cable.
- (4) If the M/C short connector is connected to the M/C power cable, remove the short connector.
- (5) Connect the external short connector to the connector of the connection cable.

NOTE
 If the external short connector is the type which is shown below, connect it with a tool.



How to use the brake release unit



CAUTION

- After releasing the brake, the arm may fall by its own weight or move to the unexpected direction. Make sure to prepare a countermeasure to prevent the arm from falling and check the operation environment is safe.
- If the arm you released its brake moves awkwardly or faster than usual, stop the operation promptly and contact the supplier of your region. The brake release unit may be broken.
 If you keep operating the Manipulator, it may lead to the breakdown of the Manipulator or you may get your hand or fingers caught.

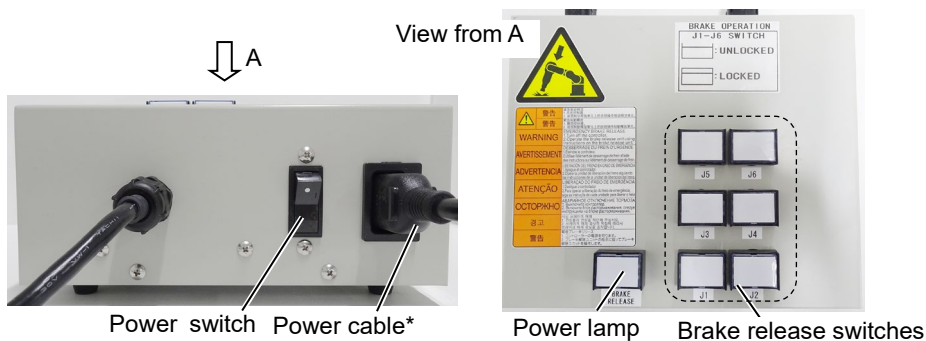

* Item you should provide

- (1) Refer to “Mount the brake release unit” above to connect the brake release unit to the connector of the connection cable.
- (2) Plug the power cable into the brake release unit.
- (3) Plug the power cable into the power supply plug.

- (4) Turn ON the brake release unit.
When the brake release unit is enabled, the power lamp lights up.
- (5) Press the switch of the arm (J1 to J6) you want to move and then move the arm.
Press the switch again. The brake will be released.
The brake will be enabled by pressing the switch once again.

NOTE  Move the arm the brake is released by two persons or more (one presses the switch and one moves the arm). The arm can be very heavy and needs the significant force to move.

6.2 Camera Plate Unit

To mount a camera to the C8 series Manipulator, you need to mount the camera plate unit first.

Appearance of arm end with camera

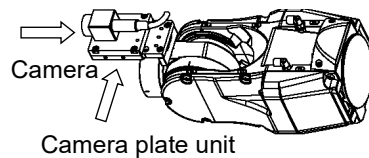

Parts included		Qty.
A	Camera adapter plate	1
B	Camera mid plate	1
C	Camera base plate	1
D	Hexagon socket head screws M4×12	6
E	Hexagon socket head screws M4×20	2
F	Plain washer for M4 (small washer)	2

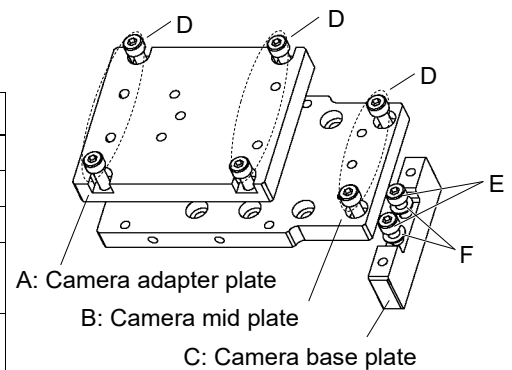

Installation

NOTE  For details of tightening the hexagon socket head screws, refer to “*Regular Inspection 2.4 Tightening Hexagon Socket Head Bolts*”

Mounting holes for the camera base plate on the C8 series Manipulator

Camera base plate
mounting hole

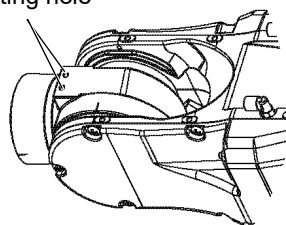

For the installation steps, refer to the following manual:
Epson RC+ Option Vision Guide Hardware & Setup

Dimension of the camera plate unit

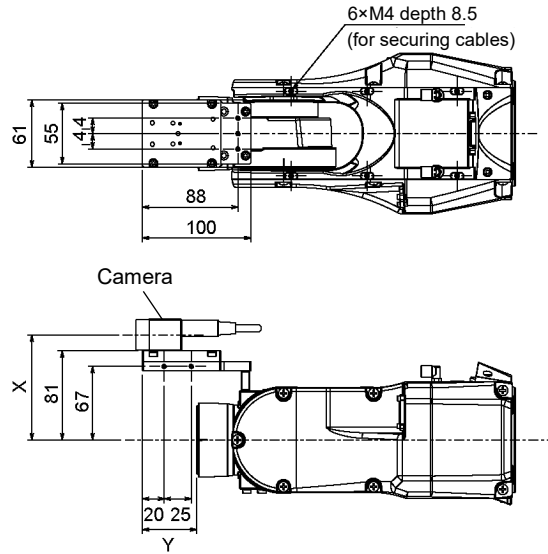

Dimensions X and Y will change depending on the position of camera mid plate and camera size. Refer to the table below for the values.

Camera mid plate

The camera mid plate uses the mounting holes A to D.

By using the different mounting holes, it can be mounted to the camera base plate in the different four positions.

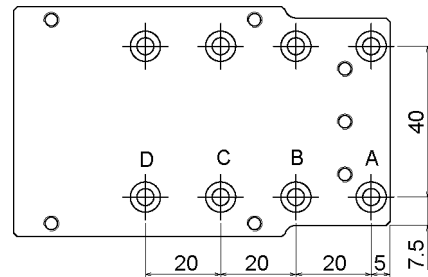

Camera and C8 series Manipulator Joint #5 motion range (reference values)

The Joint #5 motion range varies depending on the mounting position of camera mid plate and the camera you are using.

The table below shows the motion range (reference values) based on the available cameras for this option and the mounting positions of the camera mid plate. The values in the table may vary depending on how to secure the cables.

By changing the Y position, you can extend the distance from the end effector mounting surface to the camera. Also, you can attach the larger end effector. However, be careful about the Joint #5 motion range that will be limited in this case.

	A	B	C	D	X
USB camera, GigE camera	-135to +70°	-135 to +60°	-135 to +45°	-135 to +35°	95.5 mm

	A	B	C	D
Y	50 mm	30 mm	10 mm	-10 mm

Direction of the Joint #5 motion

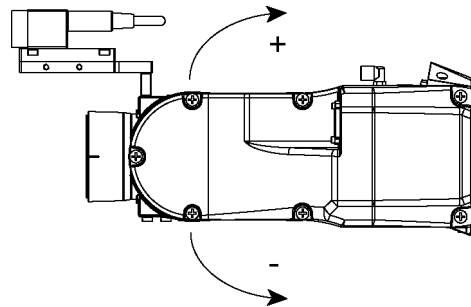

6.3 Tool Adapter (ISO Flange)

Using the tool adapter, you can mount the end effector whose dimensions are designed for the ISO flange to the C8 series Manipulators.

Parts included	Qty.
ISO flange	1
Flange	1
Pin	2
Hexagon socket head screw with low head M5×10	6
Hexagon socket head screw M5×15	4

Dimensions of ISO flange

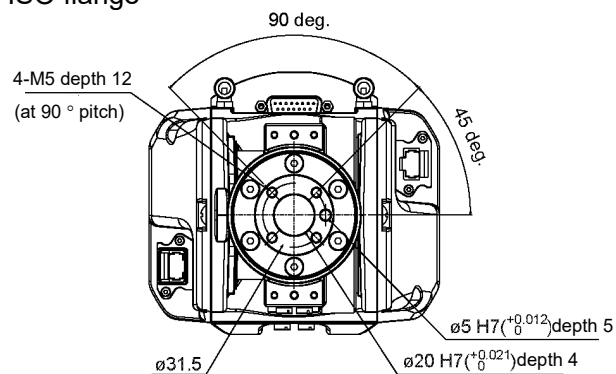

* Each dimension and tolerance complies with ISO9409-1-31.5-4-M5.

To mount the ISO flange

NOTE  For details of tightening the hexagon socket head screws, refer to “Regular Inspection 2.4 Tightening Hexagon Socket Head Bolts”

- (1) Press-fit the pin to the Arm #6 end flange.

Pin projection : 4 mm from the flange

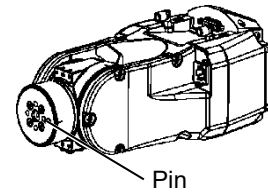

- (2) Align the pin and the pin hole on the flange, and then mount the flange.

Hexagon socket head screw: 4-M5×15

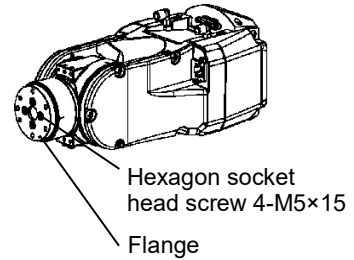

- (3) Press-fit the pin to the installed flange.

Pin protrusion: 4 mm from the flange

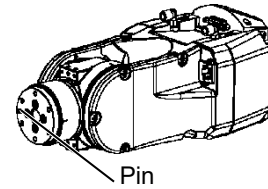

- (4) Align the pin and the pin hole on the ISO flange, and then mount the ISO flange.

Hexagon socket head screw with low head: 6-M5×10

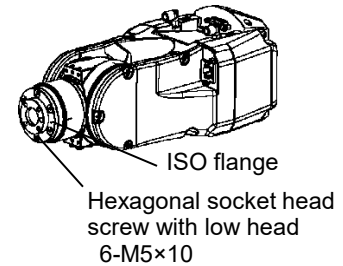

6.4 Adjustable Mechanical Stops

This option is used to mechanically limit the motion range of the Manipulator.

For installation and angle restriction measures, refer to “5.2 Motion Range Setting by Mechanical Stops”.

Adjustable mechanical stop (J1)

Item	Qty.
Adjustable mechanical stop (J1)	1
Hexagon socket head screw M12×30	2

Adjustable mechanical stop (C8/C8L J2)

Item	Qty.
Adjustable mechanical stop (C8/C8L J2)	1
Hexagon socket head screw M10×35	1

Adjustable mechanical stop (C8XL J2)

Item	Qty.
Adjustable mechanical stop(C8XL J2)	1

Adjustable mechanical stop (J3)

Item	Qty.
Adjustable mechanical stop (J3)	1

6.5 User Wires and Pneumatic Tubes

Use the following options when using the internal wiring and tubing for the end effector drive.

Fitting for customer use (ø6 straight)

Item	Qty.	Manufacturer	Standard
ø6 straight fitting	2	SMC	KQ2S06-M6N

* Attached as standard. The parts can be purchased additionally in case of lost or shortage.

Fitting for customer use (ø6 elbow)

Item	Qty.	Manufacturer	Standard
ø6 elbow fitting	2	SMC	KQ2L06-M6N

* Attached as standard. The parts can be purchased additionally in case of lost or shortage.

Standard user connector kit (D-sub)

Item	Qty.	Manufacturer	Standard
Connector	2	JAE	DA-15PF-N (Solder type)
Clamp hood	2	HRS	HDA-CTH(4-40)(10) (Connector setscrew: #4-40 UNC)

* Attached to standard and cleanroom-model Manipulators as standard.
The parts can be additionally purchased in case of lost or shortage.

Waterproof User Connector Kit (D-sub)

Item	Qty.	Manufacturer	Standard
Connector	2	HARTING	09 67 015 5615 (Solder type)
Clamp hood	2	HARTING	09 67 015 0538 (Connector setscrew: #4-40 UNC)

* Attached to the protection model Manipulators as standard.
The parts can be additionally purchased in case of lost or shortage.

Waterproof User Connector Kit (Ethernet)

Item	Qty.	Manufacturer	Standard
Connector	2	HARTING	09 45 145 1560

* Not attached as standard. Please purchase the item if needed.
Please note that the protection rating IP67 cannot be satisfied if other connectors are used.

C12 Manipulator

This volume contains information for setup and operation of the Manipulators.
Please read this volume thoroughly before setting up and operating the Manipulators.

1. Safety



Unpacking and transportation of the Manipulators and robotic equipment shall be performed by personnel who has taken robot system training held by us and suppliers and should conform to all national and local codes.

Please read this manual and other related manuals before installing the robot system or before connecting cables.

Keep this manual handy for easy access at all times and reread it when you find anything unclear.

1.1 Conventions

Important safety considerations are indicated throughout the manual by the following symbols. Be sure to read the descriptions shown with each symbol.

 WARNING	This symbol indicates that a danger of possible serious injury or death exists if the associated instructions are not followed properly.
 WARNING	This symbol indicates that a danger of possible harm to people caused by electric shock exists if the associated instructions are not followed properly.
 CAUTION	This symbol indicates that a danger of possible harm to people or physical damage to equipment and facilities exists if the associated instructions are not followed properly.

1.2 Design and Installation Safety

This product is intended for transporting and assembling parts in a safely isolated area. Design and installation of robot system shall be performed by personnel who has taken robot system training held by us and suppliers.

To ensure safety, a safeguard must be installed for the robot system. For details on the safeguard, refer to the *Installation and Design Precautions* in the *Safety* chapter of the Epson RC+ User's Guide.



The following items are safety precautions for design personnel:

 <p>WARNING</p>	<ul style="list-style-type: none">■ Personnel who design and/or construct the robot system with this product must read “<i>Safety Manual</i>”. Designing and/or constructing the robot system without understanding the safety requirements is extremely hazardous, and may result in serious bodily injury and/or severe equipment damage to the robot system.■ The Manipulator and the Controller must be used within the environmental conditions described in their respective manuals. This product has been designed and manufactured strictly for use in a normal indoor environment. Using the product in an environment that exceeds the specified environmental conditions may not only shorten the life of the product but may also cause serious safety problems.■ The robot system must be used within the installation requirements described in the manuals. Using the robot system outside of the installation requirements may not only shorten the life of the product but also cause serious safety problems.■ When designing or installing a robot system, wear at least the following protective gear. Working without protective gear may cause serious safety problems.<ul style="list-style-type: none">Work clothes suitable for workHelmetSafety shoes
--	---

Further precautions for installation are described in “3. *Environment and Installation*”. Please read this chapter carefully to understand safe installation procedures before installing the robots and robotic equipment.

1.3 Operation Safety

The following items are safety precautions for qualified Operator personnel:

 WARNING	<ul style="list-style-type: none"> ■ Please carefully read “<i>Safety Manual</i>”. Operating the robot system without understanding the safety precautions is extremely hazardous and may result in serious bodily injury and/or severe equipment damage to the robot system. ■ Do not enter the operating area of the Manipulator while the power to the robot system is turned ON. Entering the operating area with the power ON is extremely hazardous and may cause serious safety problems as the Manipulator may move even if it seems to be stopped. ■ Before operating the robot system, make sure that no one is inside the safeguarded area. The robot system can be operated in the mode for teaching even when someone is inside the safeguarded area. The motion of the Manipulator is always in restricted status (low speeds and low power) to secure the safety of an operator. However, operating the robot system while someone is inside the safeguarded area is extremely hazardous and may result in serious safety problems in case that the Manipulator moves unexpectedly. ■ Immediately press the Emergency Stop switch whenever the Manipulator moves abnormally during operation. Continuing the operation while the Manipulator moves abnormally is extremely hazardous and may result in serious bodily injury and/or severe equipment change to the robot system.
 WARNING	<ul style="list-style-type: none"> ■ Be sure to connect the AC power cable to a power receptacle. DO NOT connect it directly to a factory power source. To shut off power to the robot system, disconnect the power plug from the power source. Performing any work while connecting the AC power cable to a factory power source is extremely hazardous and may result in electric shock and/or malfunction of the robot system. ■ Before performing any replacement procedure, turn OFF the Controller and related equipment, and then disconnect the power plug from the power source. Performing any replacement procedure with the power ON is extremely hazardous and may result in electric shock and/or malfunction of the robot system. ■ Do not connect or disconnect the motor connectors while the power to the robot system is turned ON. Connecting or disconnecting the motor connectors with the power ON is extremely hazardous and may result in serious bodily injury as the Manipulator may move abnormally, and also may result in electric shock and/or malfunction of the robot system.

 CAUTION	<ul style="list-style-type: none"> ■ Whenever possible, only one person should operate the robot system. If it is necessary to operate the robot system with more than one person, ensure that all people involved communicate with each other as to what they are doing and take all necessary safety precautions. ■ If the joints are operated repeatedly with the operating angle less than 5 degrees, they may get damaged early because the bearings are likely to cause oil film shortage in such situation. To prevent early breakdown, move each joint larger than 30 degrees for about once an hour. ■ Vibration (resonance) may occur continuously depending on the combination of robot motion speed, Arm orientation, and end effector load. Vibration arises from natural vibration frequency of the Arm and can be controlled by following measures. <ul style="list-style-type: none"> Changing Manipulator speed Changing the teach points Changing the end effector load
---	--

1.4 Emergency Stop

If the Manipulator moves abnormally during operation, immediately press the Emergency Stop switch. Pressing the Emergency Stop switch immediately changes the Manipulator to deceleration motion and stops it at the maximum deceleration speed.

Avoid pressing the Emergency Stop switch unnecessarily while the Manipulator is running normally.

- The Manipulator may hit the peripheral equipment.

When you press the Emergency Stop switch, the operating trajectory until the robot system stops is different from that in normal operation.

- The life of the brakes will be shortened.

The brakes are locked and the brake friction plate is worn.

Normal brake life cycle: About 2 years (when the brakes are used 100 times/day)

However, the rough normal relay life is approximately 20,000 times. If you press the emergency stop switch unnecessarily, the life of the relay will be shortened.

- Impact is applied on the reduction gear unit, and it may result in the short life of the reduction gear unit.

To place the robot system in emergency mode during normal operation, press the Emergency Stop switch while the Manipulator is not moving.

Refer to the Robot Controller manual for instructions on how to wire the Emergency Stop switch circuit.

Do not turn OFF the Controller while the Manipulator is operating.

If you attempt to stop the Manipulator in emergency situations, make sure to stop the Manipulator using the E-STOP of the Controller.

If the Manipulator is stopped by turning OFF the Controller while it is operating, the following problems may occur.

Reduction of the life and damage of the reduction gear unit

Position gap at the joints

In addition, if the Controller was forced to be turned OFF by blackouts and the like while the Manipulator is operating, make sure to check the following points after power restoration.

Whether or not the reduction gear is damaged

Whether or not the joints are in their proper positions

If there is a position gap, perform calibration by referring to “*C series Maintenance Manual 16. Calibration*”.

Before using the Emergency Stop switch, be aware of the followings.

- The Emergency Stop (E-STOP) switch should be used to stop the Manipulator only in case of emergencies.
- To stop the Manipulator operating the program except in emergency, use Pause (halt) or STOP (program stop) commands.
Pause and STOP commands do not turn OFF the motors. Therefore, the brake does not function.
- For the safeguard, do not use the E-STOP circuit.

To check brake problems, refer to “*Regular Inspection 1. Regular Inspection for C12 Manipulator*”.

NOTE



Test pulse cannot be used with the emergency stop input of this model.

Stopping distance in emergency

The Manipulator in operation cannot stop immediately after the Emergency Stop switch is pressed. In addition, stopping time and stopping distance vary by following factors:

Hand weight	WEIGHT Setting	ACCEL Setting
Workpiece weight	SPEED Setting	Posture etc.

For stopping time and stopping distance of the Manipulator, refer to “*Appendix B: Stopping Time and Stopping Distance in Emergency*”.

1.5 Safeguard

To ensure safe operation, install a safety system using safety doors, light curtains, safety floor mats, etc.

When a closed safeguard is open during robot motion, the safeguard interlock function operates. The robot stops immediately and enters into pause state. Then, all robot motors are turned OFF. The descriptions below explain how the safeguard input works.

Safeguard open : The robot stops immediately, motors are turned OFF, and further operation is impossible until either the safeguard is closed or TEACH or TEST mode is turned ON and the enable circuit is engaged.

Safeguard closed : The robot can automatically operate in unrestricted (high power) state.

Do not open the safeguard unnecessarily while motor is ON. Frequent safeguard inputs affect the life of the relay.

Rough normal relay life: Approximately 20,000 times

For the safeguard, do not use the E-STOP circuit.

For details of wiring instructions, refer to the following manuals.

RC90 series Manual 9. *EMERGENCY*

RC700 series Manual 11. *EMERGENCY*

For details of the safeguard, refer to the following manuals as well.

RC90 series Manual 2.7.1 *Connection to EMERGENCY Connector*

RC700 series Manual 2.7.1 *Connection to EMERGENCY Connector*

NOTE



Test pulse cannot be used with the safeguard input of this model.

 WARNING	<ul style="list-style-type: none"> ■ The EMERGENCY connector on the controller has a safeguard input circuit to connect the safety device interlock switch. To protect operators working near the robot, be sure to connect the interlock switch and make sure that it works properly. ■ The time to stop the robot and the stopping distance by the safeguard interlock function will change depending on the conditions of use. Be sure to confirm that safety is ensured according to the installation environment of the robot.
---	---

Stopping distance when the safeguard is opened

The Manipulator in operation cannot stop immediately after the safeguard is opened. In addition, stopping time and stopping distance vary by following factors:

Hand weight	WEIGHT Setting	ACCEL Setting
Workpiece weight	SPEED Setting	Posture etc.

For stopping time and stopping distance of the Manipulator, refer to “*Appendix C: Stopping Time and Stopping Distance When the Safeguard is Opened*”.

1.6 How to Move Arms with the Electromagnetic Brake

There are two methods to release the electromagnetic brake. Follow either method to release the electromagnetic brake and move the arms manually.

1.6.1 Moving the arm using the brake release unit

Follow the method when you just unpack the delivered boxes or when the Controller does not start up yet.

1.6.2 Moving the arm using the software

Follow the method when you can use the software.

While the electromagnetic brake is ON (such as in emergency mode), you cannot move any arm by pushing manually.

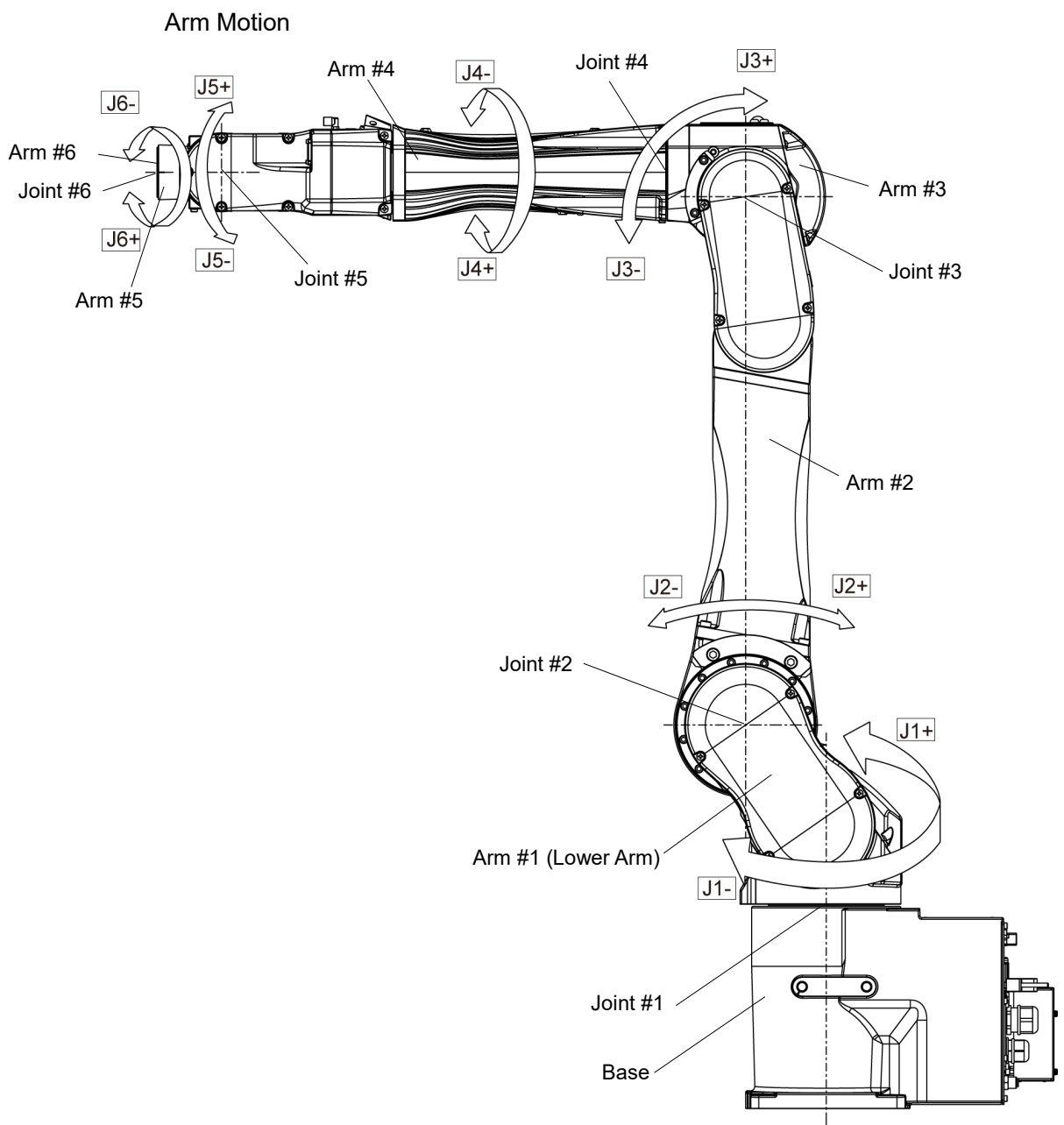

1.6.1 Moving the Arm using the brake release unit

The C12 series has the Brake Release Unit as an option.
For details, refer to “6 Options”.

1.6.2 Moving the Arm using the software

 CAUTION	<ul style="list-style-type: none"> ■ Normally, release the brake of joints one by one. Take extra care if you need to release the brakes of two or more joints simultaneously. Releasing the brakes of two or more joints simultaneously may cause hands and fingers to be caught and/or equipment damage to or malfunction of the Manipulator as the arms of the Manipulator may move in unexpected directions. ■ Be careful of the arm falling when releasing the brake. While the brake is being released, the Manipulator’s arm falls by its own weight. The arm falling may cause hands and fingers to be caught and/or may cause equipment damage to or malfunction of the Manipulator. ■ Before releasing the brake, be sure to keep the Emergency Stop switch handy so that you can immediately press the Emergency Stop switch. Otherwise, you cannot immediately stop the arm falling due to an erroneous operation. The arm falling may cause equipment damage to and/or malfunction of the Manipulator.
---	--

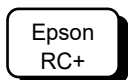

After releasing the Emergency Stop switch, execute the following command in [Command Window].

```
>Reset
>Brake Off, [the number (from 1 to 6) corresponding to the arm whose brake will be turned OFF]
```

Execute the following command to turn on the brake again.

```
>Brake On, [The number (from 1 to 6) corresponding to the arm whose brake will be turned ON]
```

1.7 Precaution for Operation in Low Power Status

In the low power status, the Manipulator operates at low speed and low torque. However, comparatively high torque as shown in the table below may be generated to support the Manipulator’s own weight.

Carefully operate the Manipulator since it may get your hands or fingers caught during operation. The Manipulator may also collide with peripheral equipment and cause equipment damage to or malfunction of the Manipulator.

Maximum Joint Torque in Low Power Status [Unit: N·m]

Joint		#1	#2	#3	#4	#5	#6
Joint Torque	C12-A1401** (C12XL)	573.1	517.7	256.9	57.4	53.4	23.9

 CAUTION	<ul style="list-style-type: none"> ■ Carefully operate the Manipulator in the low power status. A comparatively high joint torque may be generated. It may cause your hands and fingers caught and/or cause equipment damage to or malfunction of the Manipulator as it may collide with peripheral equipment.
---	---

1.8 Warning Labels



The Manipulator has the following warning labels.

The warning labels are attached around the locations where specific dangers exist.

Be sure to comply with descriptions and warnings on the labels to operate and maintain the Manipulator safely.

Do not tear, damage, or remove the warning labels. Use meticulous care when handling those parts or units to which the following warning labels are attached as well as the nearby areas.

Location	Warning Label	NOTE
<p>A</p>		<p>To avoid getting hands or fingers caught, fold the Arm and fix it with a belt or a similar tool before removing the base mounting screws.</p>
<p>B</p>		<p>Do not enter the work space when the Manipulator is operating. It is extremely hazardous since the Arm may collide and cause serious safety problems.</p>
<p>C</p>		<p>Do not touch the current-carrying parts inside the Manipulator while the power is ON. It may cause electrical shock.</p>

Location	Warning Label	NOTE
D	 <p>警告 WARNING 警告 AVERTISSEMENT 警告 ADVERTENCIA 경고 ATENÇÃO ОСТОРОЖНО ОСТОРОЖНО</p> <p>当心夹手 当心夹手 挟み込みの危険 警告 注意 ОПАСНОСТЬ ПАЗРАБОТКИ</p> <p>CRUSH HAZARD RISQUE D'ÉCRASEMENT PELIGRO DE APLASTAMIENTO PERIGO DE ESMAGAMENTO ОПАСНОСТЬ ПАЗРАБОТКИ</p> <p>请勿将手放在活动部件上。 请勿将手放在移动部件上。 Do not put your hand on moving parts. Ne pas placer les mains sur les pièces mobiles. No ponga la mano sobre las piezas móviles. Não coloque a mão nas peças móveis. Не кладите руку на движущиеся части. 가동부위 손을 대지 마십시오. 動部分に手を置かないでください。</p> <p>警告 紧急制动释放 1. 按照制动释放单元上的说明操作制动释放单元。 警告 紧急制动释放 1. 按照制动释放单元上的说明操作制动释放单元。 EMERGENCY BRAKE RELEASE 1. Turn off the controller. 2. Operate the brake release unit using instructions on the brake release unit. DESSERRAGE DU FREIN D'URGENCE 1. Eteindre le contrôleur. 2. Utiliser l'élément de desserrage de frein d'urgence des instructions sur l'élément de desserrage de frein. LIBERACIÓN DEL FRENO EN CASO DE EMERGENCIA 1. Apague el controlador. 2. Opere la unidad de liberación del freno siguiendo las instrucciones de la unidad de liberación del freno. LIBERAÇÃO DO FREIO DE EMERGENCIA 1. Desligue o controlador 2. Para operar a liberação do freio de emergência, siga as instruções de cada unidade para liberar o freio. АВАРИЙНОЕ ОТКЛЮЧЕНИЕ ТОРМОЗА 1. Выключите контроллер. 2. Выполните блок растормаживания, следуя инструкциям на блоке растормаживания. 경고 비상 브레이크 해제 1. 컨트롤러 전원을 차단해 주십시오. 2. 브레이크 해제 유닛의 지시에 따라서 브레이크 해제 유닛을 조작합니다. 警告 緊急ブレーキリリース 1. コントローラーの電源を切ります。 2. ブレーキ解除ユニットの指示に従ってブレーキ解除ユニットを操作します。</p>	<p>You may get your hand or fingers caught when bringing your hand close to moving parts.</p>
E	 <p>警告 WARNING 警告 AVERTISSEMENT 警告 ADVERTENCIA 경고 ATENÇÃO ОСТОРОЖНО ОСТОРОЖНО</p> <p>当心落下 当心落下 落下の危険 注意 위험 ОПАСНОСТЬ ПАДЕНИЯ</p> <p>FALLING HAZARD RISQUE DE CHUTE PELIGRO DE CAIDAS PERIGO DE QUEDA ОПАСНОСТЬ ПАДЕНИЯ</p> <p>紧急制动释放 1. 按照制动释放单元上的说明操作制动释放单元。 警告 紧急制动释放 1. 按照制动释放单元上的说明操作制动释放单元。 EMERGENCY BRAKE RELEASE 1. Turn off the controller. 2. Operate the brake release unit using instructions on the brake release unit. DESSERRAGE DU FREIN D'URGENCE 1. Eteindre le contrôleur. 2. Utiliser l'élément de desserrage de frein d'urgence des instructions sur l'élément de desserrage de frein. LIBERACIÓN DEL FRENO EN CASO DE EMERGENCIA 1. Apague el controlador. 2. Opere la unidad de liberación del freno siguiendo las instrucciones de la unidad de liberación del freno. LIBERAÇÃO DO FREIO DE EMERGENCIA 1. Desligue o controlador 2. Para operar a liberação do freio de emergência, siga as instruções de cada unidade para liberar o freio. АВАРИЙНОЕ ОТКЛЮЧЕНИЕ ТОРМОЗА 1. Выключите контроллер. 2. Выполните блок растормаживания, следуя инструкциям на блоке растормаживания. 경고 비상 브레이크 해제 1. 컨트롤러 전원을 차단해 주십시오. 2. 브레이크 해제 유닛의 지시에 따라서 브레이크 해제 유닛을 조작합니다. 警告 緊急ブレーキリリース 1. コントローラーの電源を切ります。 2. ブレーキ解除ユニットの指示に従ってブレーキ解除ユニットを操作します。</p>	<p>When releasing the brakes, be careful of the arm falling due to its own weight.</p> <p>This warning label is attached on the Manipulator and optional brake release unit as well.</p>
F	 <p>警告 WARNING 警告 AVERTISSEMENT 警告 ADVERTENCIA 경고 ATENÇÃO ОСТОРОЖНО ОСТОРОЖНО</p> <p>小心搬运 小心搬运 持ち上げ注意 주의해서 들어 올리십시오. LEVANTE COM CUIDADO LEVANTE COM CUIDADO LEVANTE COM CUIDADO ПОДНИМАЙТЕ ОСТОРОЖНО</p> <p>LIFT WITH CARE SOULEVEZ AVEC SOIN LEVANTAR CON CUIDADO LEVANTE COM CUIDADO LEVANTE COM CUIDADO ПОДНИМАЙТЕ ОСТОРОЖНО</p> <p>在装卸和运输过程中，请遵照说明书。 在装卸和运输过程中，请遵照说明书。 Follow instructions manual during lifting and transportation. Respecter les instructions du manuel d'utilisation pendant le levage et le transport. Siga el manual de instrucciones durante la instalación y el transporte. Siga as instruções do manual para içar e transportar o robô. При подъеме и транспортировке следуйте инструкциям в руководстве. 경고 본 작업에서 사용 설명서를 따라 주십시오. 警告 持ち上げおよび輸送は、取扱説明書に従ってください。</p>	<p>Only authorized personnel should perform sling work and operate a crane and a forklift. When these operations are performed by unauthorized personnel, it is extremely hazardous and may result in serious bodily injury and/or severe equipment damage to the robot system.</p>

Location	Warning Label	NOTE
G		<p>HOT Be careful not to burn yourself.</p>

Location	Label	NOTE
1	-	<p>The product name, model name, serial number, information which laws and regulations are supported, product specifications, manufacturer, importer, date of manufacture, country of manufacture, etc. are listed.</p> <p>For details, see the label affixed to the product.</p>

Location of Labels

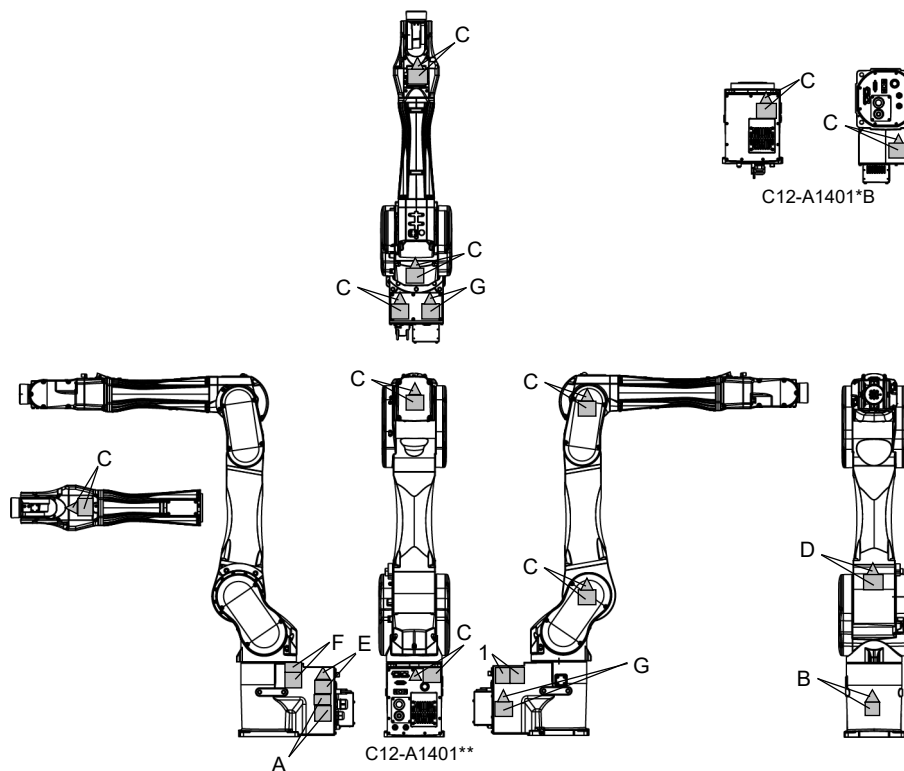

1.9 Response for Emergency or Malfunction

1.9.1 Collision

When the Manipulator collides with a mechanical stopper or peripheral device etc., discontinue use and contact the supplier.

1.9.2 Getting body caught in Manipulator

When the operator is caught between the Manipulator and a mechanical part such as a base table, press the emergency stop switch to release the brake on the subject arm, and then move the arm by hand.

How to release a brake

When using a brake release unit

For details, refer to “*6.1 Brake Release Unit*”.

When using software

For details, refer to “*1.6.2 Moving the Arm using the software*”.

2. Specifications

2.1 Model Number

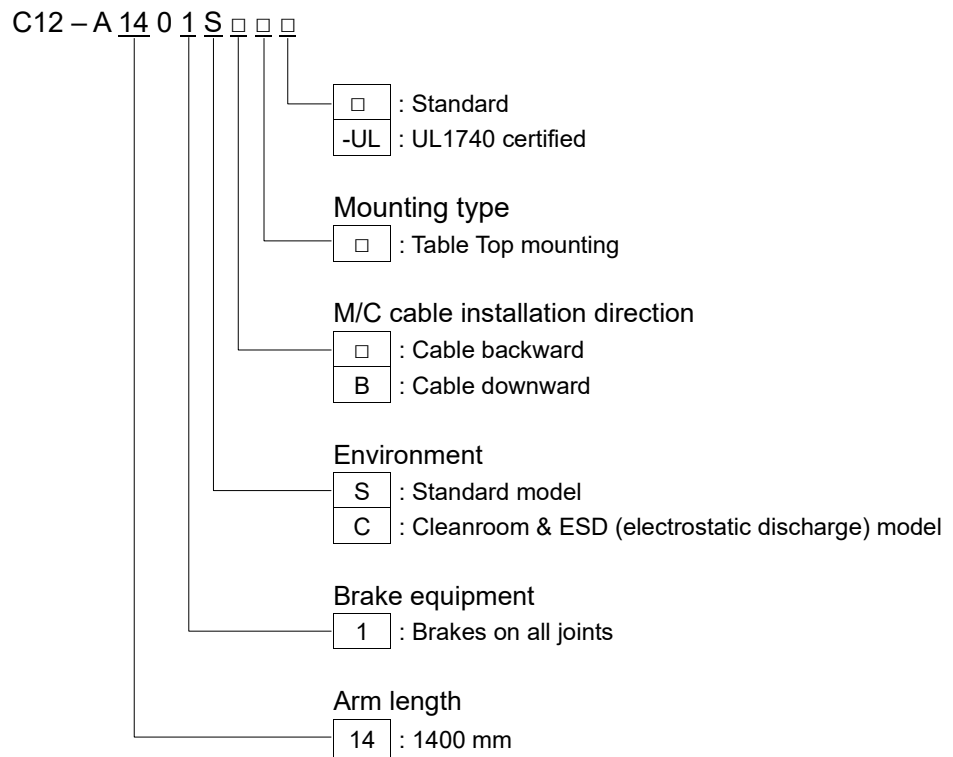

2.2 Part Names and Motion Range of Each Arm

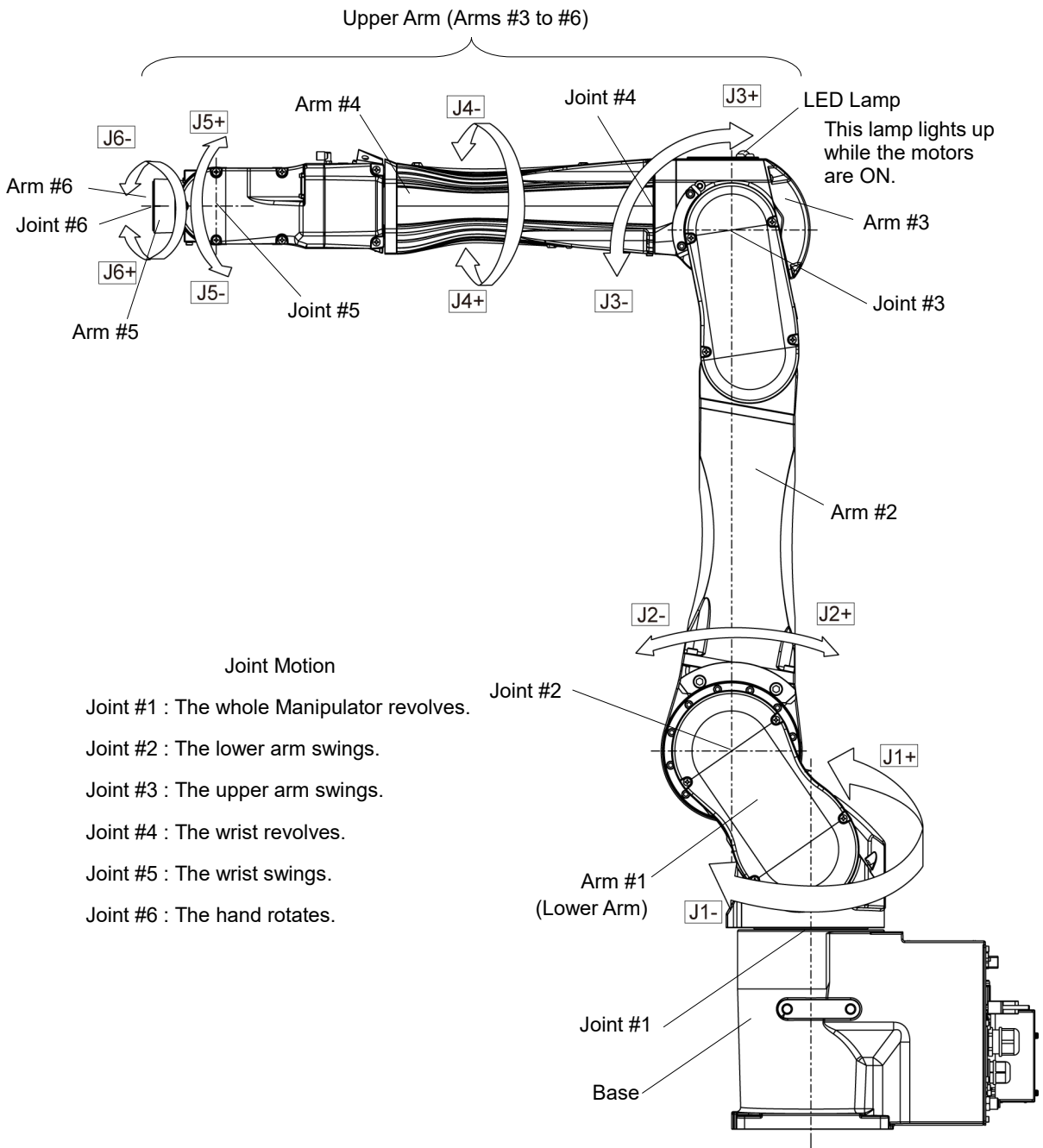

- Joint Motion
- Joint #1 : The whole Manipulator revolves.
 - Joint #2 : The lower arm swings.
 - Joint #3 : The upper arm swings.
 - Joint #4 : The wrist revolves.
 - Joint #5 : The wrist swings.
 - Joint #6 : The hand rotates.

NOTE When the LED lamp is lighting or the Controller power is on, current is being applied to the Manipulator. (The LED lamp may not be seen depending on the Manipulator's posture. Be very careful.) Performing any work with the power ON is extremely hazardous and it may result in electric shock and/or improper function of the robot system. Make sure to turn OFF the Controller power before the maintenance work.

Cable backward model

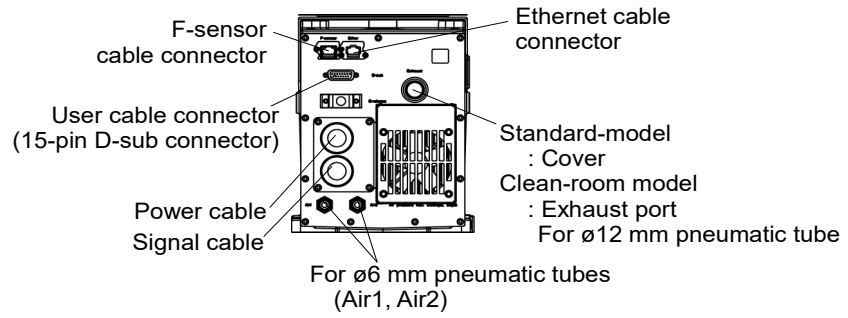

Cable downward model

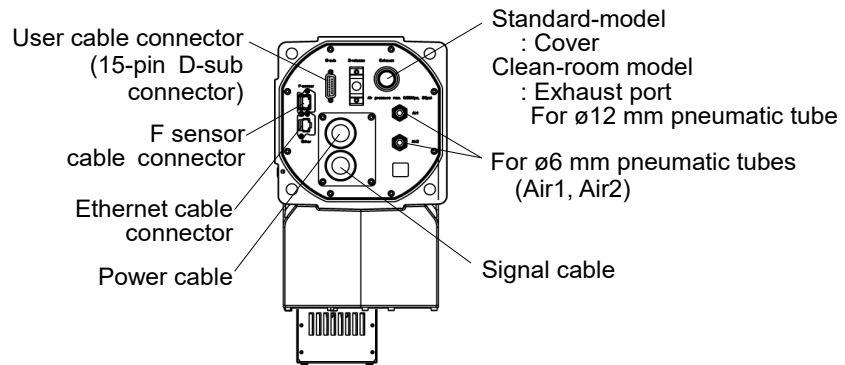

Cable backward model / Cable downward model

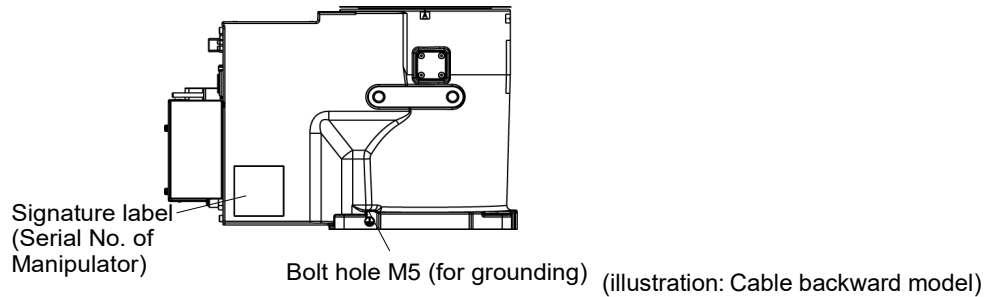

2.3 Outer Dimensions

[Unit: mm]

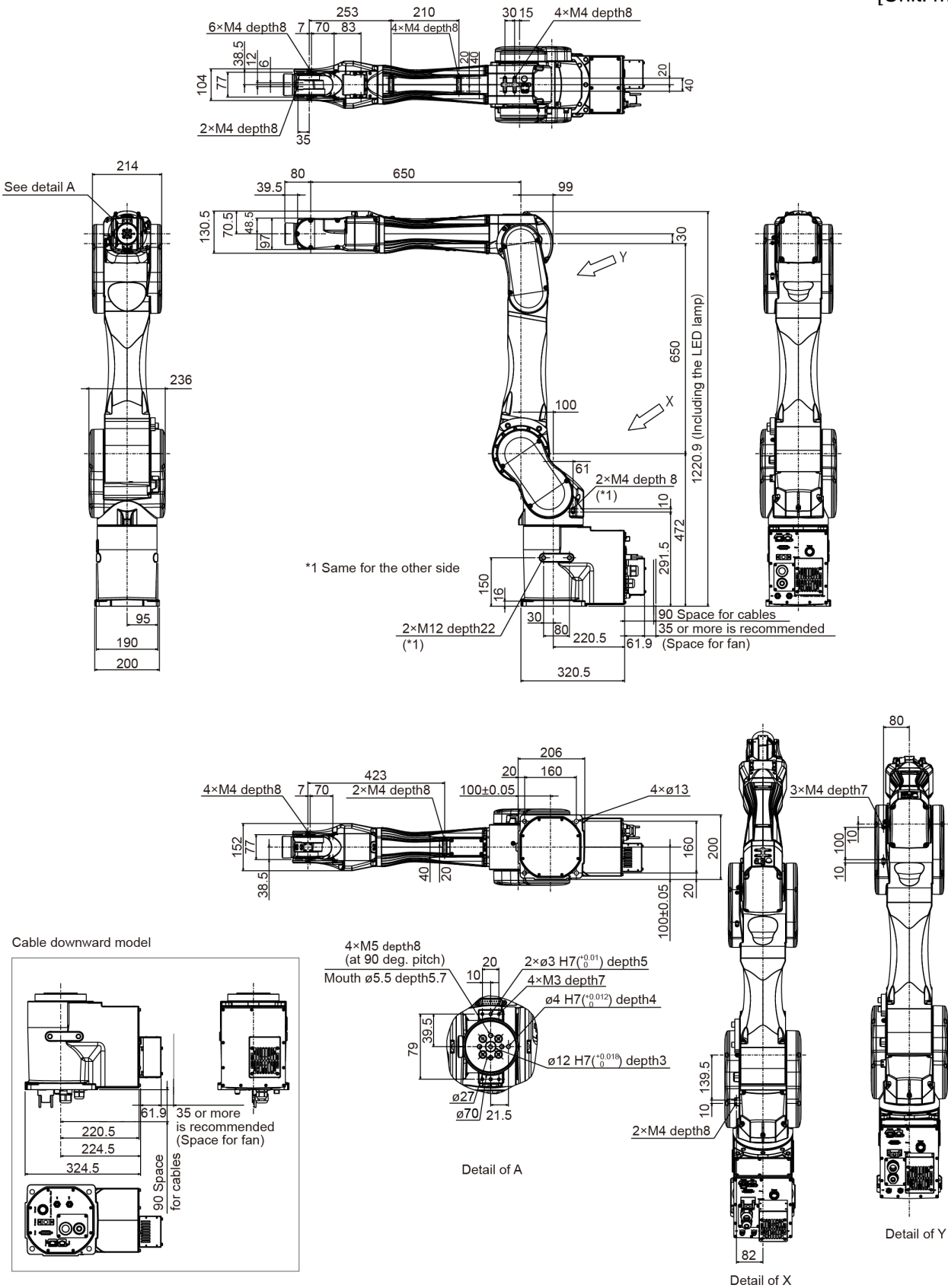

2.4 Standard Motion Range

[Unit: mm]

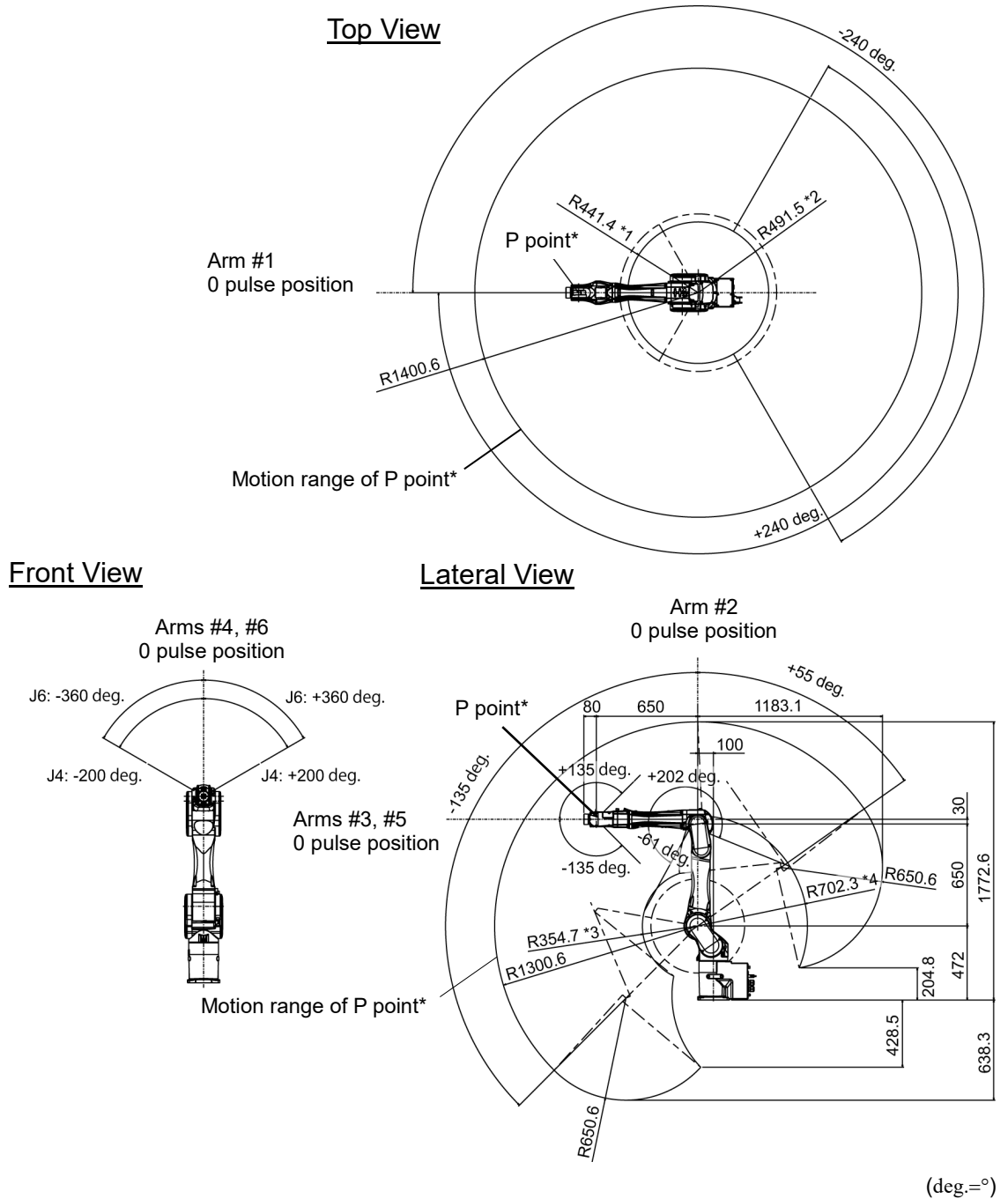

- * P point : Intersection of the rotation centers for Joints #4, #5, and #6
- *1 : P point from top with Joint #3 declining -61° (Joint #1 center – P point center)
- *2 : P point from top with Joint #3 tilting up $+202^\circ$ (Joint #1 center – P point center)
- *3 : P point from lateral with Joint #3 declining -61° (Joint #2 center – P point center)
- *4 : P point from lateral with Joint #3 tilting up $+202^\circ$ (Joint #2 center – P point center)

 CAUTION	<p>■ Pay attention to the arm pose of the basic arms (Arms #1, #2, and #3) when operating the Manipulator. Arm #5 moves keeping a constant angle regardless of the arm pose. Depending on the arm pose of the basic arms, the wrist may collide with the Manipulator. The collision may cause equipment damage to and/or malfunction of the Manipulator.</p>
--------------------	--

2.5 Specifications

2.5.1 Specifications Table

For the specification of each model, refer to “*Appendix A: Specifications Table*”.

2.5.2 Option

C12 series have the following options.

For details of options, refer to “*6. Options*”.

User wires and pneumatic tube

Standard user connector kit	: Standard D-sub 15-pin × 2
Fittings for customer use	: ø6, straight × 2 ø6, elbow × 2

Adjustable mechanical stop

Adjustable mechanical stop	: J1 J2 J3
----------------------------	------------------

Tool adapter

C8 ISO flange (J6)

Camera plate unit

Camera mounting tool (common for C3, C4 and C8 series)

Brake release unit *1

For EU (power supply voltage 200 V, short connector included)

For US/JP(power supply voltage 100 V, short connector included)

Short connector for the brake release unit

*1: When using the brake release unit with C12 series, it is necessary to connect the short connector to the M/C power cable or connect the M/C power cable with the Controller. (The brake release unit can be used while the Controller is de-energized state.)

If you are using C3, C4, or C8 series Manipulator and already have the brake release unit, you can use it by connecting the M/C cable with the Controller, or purchasing the short connector separately and connecting it to the M/C power cable.

2.6 How to Set the Model

The Manipulator for your system has been set before shipment.



- When you need to change the setting of the Manipulator model, be sure to set the Manipulator model properly. Improper setting of the Manipulator model may result in abnormal or no operation of the Manipulator and/or cause safety problems.



If the custom specifications number (MT***) or (X***) is described on the signature label (S/N label), the Manipulator has custom specifications. (A label with only the custom specifications number may be attached depending on shipment time.)

The custom specifications may require a different configuration procedure; check the custom specifications number and contact the supplier of your region when necessary.

The Manipulator model can be set from software.

Refer to the chapter *Robot Configuration* in the *Epson RC+ User's Guide*.

3. Environment and Installation

Unpacking and transportation of the Manipulators and robotic equipment shall be performed by personnel who has taken robot system training held by us and suppliers and should conform to all national and local codes.

3.1 Environmental Conditions

A suitable environment is essential for the robot system to function properly and safely. Be sure to install the robot system in an environment that meets the following conditions:

Item	Conditions
Ambient temperature* ¹	5 to 40 °C
Ambient relative humidity	10 to 80 % (no condensation)
Fast transient burst noise	1 kV or less (Signal wire)
Electrostatic noise	4 kV or less
Altitude	1000 m or lower
Environment	<ul style="list-style-type: none"> - Install indoors - Keep away from direct sunlight - Keep away from dust, oily smoke, salinity, metal powder or other contaminants - Keep away from flammable or corrosive solvents and gases - Keep away from water - Keep away from shock or vibration - Keep away from sources of electric noise - Keep away from explosive area - Keep away from a large quantity of radiation

*1 The ambient temperature conditions are for the Manipulators only. For the Controller which the Manipulator is connected to, refer to the Robot Controller manual.

When the product is used in a low temperature environment around the minimum temperature of the product specification, or when the product is suspended for a long time on holidays or at night, a collision detection error may occur due to the large resistance of the drive unit immediately after the start of operation. In such a case, it is recommended to warm up for about 10 minutes.

NOTE When using the Manipulators in inadequate environments that do not meet the above conditions, please contact the supplier of your region.

 WARNING	<ul style="list-style-type: none"> ■ Use an earth leakage breaker on the AC power cable of the Controller to avoid the electric shock and circuit breakdown caused by an unexpected water leak. Prepare the earth leakage breaker that pertains the Controller you are using. For details, refer to the Robot Controller manual.
--------------------	---



 CAUTION	<ul style="list-style-type: none"> ■ When cleaning the Manipulator, do not rub it strongly with alcohol or benzene. It may lose luster on the coated face.
--------------------	---

3.2 Unpacking, Transportation, and Relocation

Using a cart or similar equipment, transport the Manipulator in the same conditions as it was delivered. Observe the following when unpacking the Manipulator.

Unpacking, transportation, and relocation shall be performed by personnel who has taken robot system training held by us and suppliers and should conform to all national and local codes.

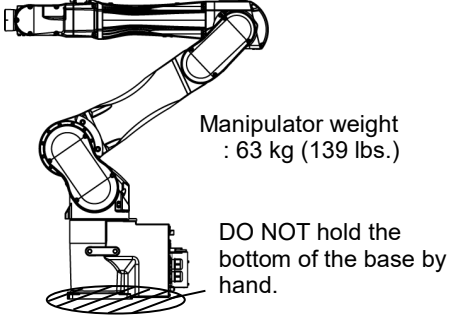
 WARNING	<ul style="list-style-type: none"> ■ Only authorized personnel should perform sling work and operate a crane or a forklift. When these operations are performed by unauthorized personnel, it is extremely hazardous and may result in serious bodily injury and/or severe equipment damage to the robot system. ■ Stabilize the Manipulator with your hands when hoisting it. Unstable hoisting is extremely hazardous and may result in serious bodily injury and/or severe equipment damage to the robot system as the fall of the Manipulator.
---	--

 CAUTION	<ul style="list-style-type: none"> ■ When removing the anchor bolts, support the Manipulator to prevent falling. Removing the anchor bolts without supporting the Manipulator may get hands, fingers, or feet caught as the Manipulator may fall. ■ To transport the Manipulator, secure it to the delivery equipment or have at least 2 people to hold it by hand. Also, do not hold the bottom of the base (the screened parts in the figure). Holding these parts by hand is extremely hazardous and may cause your hands and fingers caught. <div style="text-align: center; margin: 10px 0;">  </div> <ul style="list-style-type: none"> ■ Avoid excessive vibration or shock during Manipulator transporting. Excessive vibration or shock may cause equipment damage to and/or malfunction of the Manipulator. ■ Take extra care when transporting the Manipulator. You may hit and damage the connector <div style="text-align: center; margin-top: 10px;">  </div>
---	--

Be sure to transport and store the robot system in environments that meet the following conditions:

Item	Conditions
Ambient temperature	-20 to 60 °C
Ambient relative humidity	10 to 90 % (no condensation)

During unpacking and relocation, avoid applying external force to the arms and motors of the Manipulator.

When transporting the Manipulator for a long distance, secure it to the delivery equipment so that the Manipulator cannot fall. If necessary, pack the Manipulator in the same way as it was delivered.

When condensation occurs on the Manipulator during transport or storage, turn ON the power only after the condensation dries.

When using the Manipulator for the robot system again after long-term storage, perform a test run to verify that the Manipulator works properly. Then, operate the Manipulator thoroughly.

Relocating

Follow the procedures described below when relocating the Manipulator.

- (1) Turn OFF the power for all devices and unplug the power cable connector and signal cable connector from the Controller.

Do not unplug the M/C cable (power cable and signal cable) from the Manipulator. (M/C cable 3 m: 2 kg)

NOTE



Remove the mechanical stops if using them to limit the motion range.

For details on the motion range, refer to “5.2 Motion Range Setting by Mechanical Stops”.

- (2) Unscrew the anchor bolts. Then, remove the Manipulator from the base table.

- (3) Position the Manipulator as shown in the figure. Then, secure the Manipulator to the delivery equipment or have at least 2 people to transport the Manipulator.

Recommend: Joint #2 +55°
Joint #3 -55°

* The posture is common to all models.

Do not hold the bottom of the base (the screened parts in the figure). Holding these parts by hand is extremely hazardous and may cause your hands and fingers to be caught.

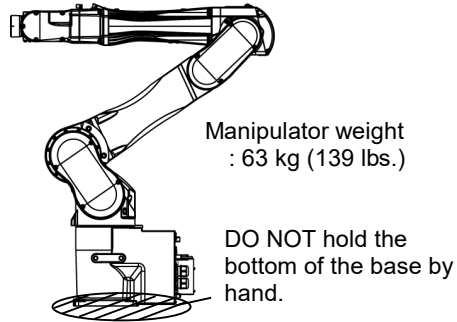

Using Eyebolt

Check that the eyebolts are securely fastened before carrying the Manipulator.

After transporting the Manipulator, remove the eyebolts and keep them for future use.

The eyebolts (accessory, 2 pcs) and wire must be strong enough to withstand the weight (See the figures below).

If you use the eyebolts to lift up the Manipulator, make sure to put hands on it to keep the balance. The Manipulator may fall if the balance is lost and this is extremely hazardous.

To prevent damage on the covers and arms, it is recommended to protect the contacting parts of the wire and arm with a cloth. Be very careful not to damage the covers since they are made of plastic.

Manipulator weight: 63 kg (139 lbs.)

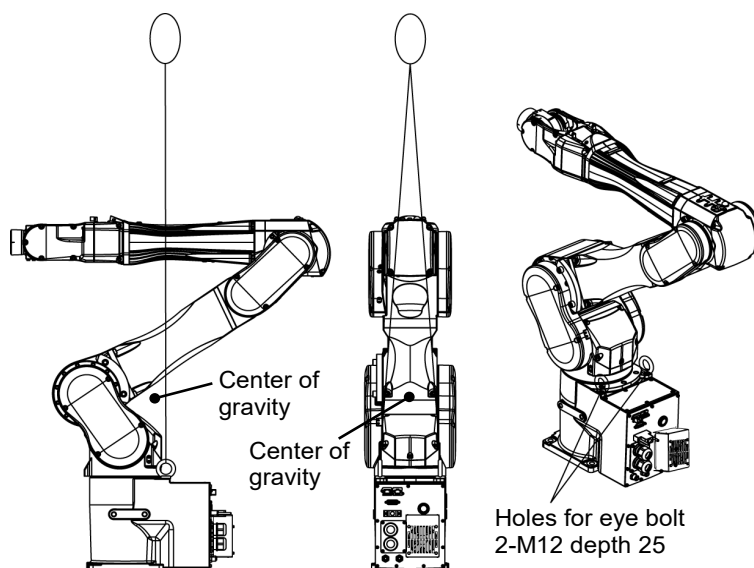

* Locations of the screw holes for eyebolts are common to all models.

 CAUTION	<ul style="list-style-type: none"> ■ Remove the eyebolts from the Manipulator after transportation/relocation is completed. <p>If the Manipulator is operated with the eyebolts left on it, the arm may collide with the eyebolts and it may cause equipment damage to and/or malfunction of the Manipulator.</p>
---	--

3.3 Mounting Dimensions

Mounting Area

Be sure to have the following space available in addition to the space for mounting the Manipulator, Controller, and peripheral equipment.

- Space for teaching points
- Space for maintenance and inspections (for installing jigs)
- Space for cables

NOTE  When installing the cable, be sure to maintain sufficient distance from obstacles.
 For the minimum bend radius of the MC cable, refer to "Appendix A: C12 Specifications."
 In addition, leave enough space for other cables so that they are not bent forcibly.

NOTE  Make sure to leave 35 mm or more space around the fan cover.

[Unit: mm]

3.3.1 Cable Backward Model

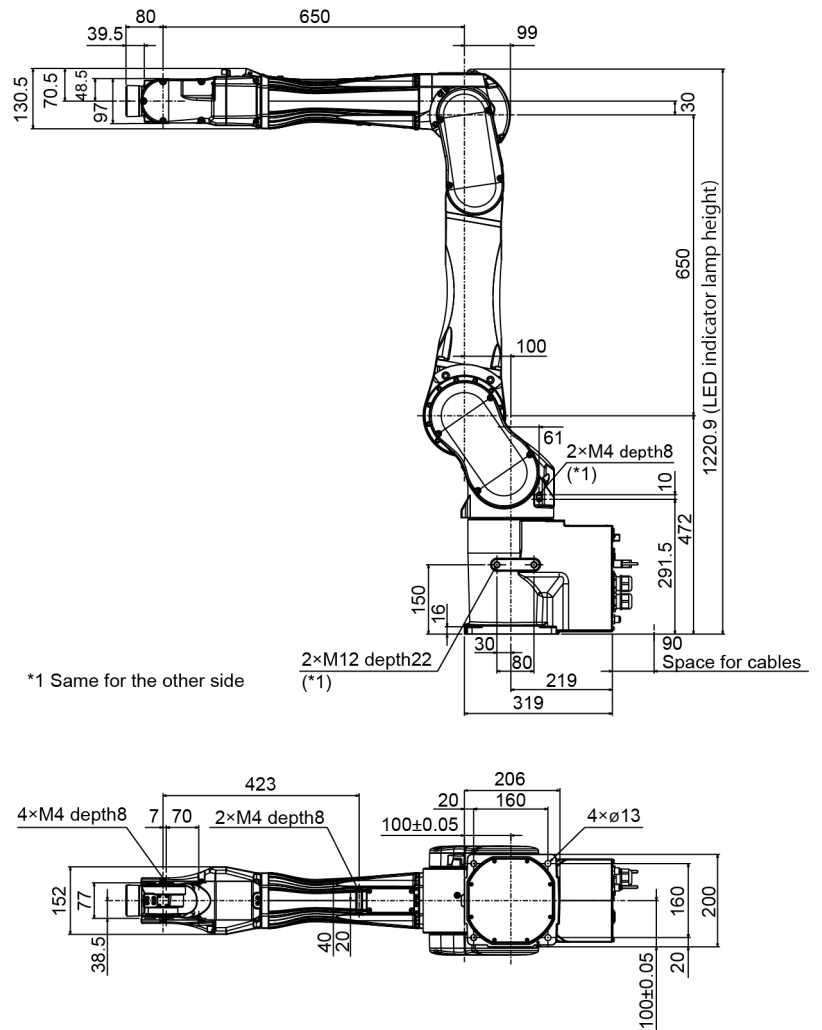

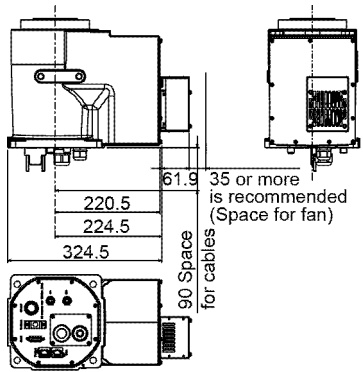

3.3.2 Cable Downward Model

The following part differs from the cable backward model.



3.4 Installation

The installation shall be made by personnel who has taken robot system training held by us and suppliers and should conform to all national and local codes.

 <p>WARNING</p>	<ul style="list-style-type: none"> ■ To ensure safety, a safeguard must be installed for the robot system. For details on the safeguard, refer to the <i>Installation and Design Precautions</i> in the <i>Safety</i> chapter of the Epson RC+ User's Guide. ■ Install the Manipulator in a location with sufficient space so that a tool or a work piece does not touch a wall or a safeguard when the Manipulator extends its arm fully while holding a work piece. Installing the Manipulator at a location with insufficient space is extremely hazardous and may result in serious bodily injury and/or severe equipment damage to the robot system as a tool or a work piece may collide with a wall or a safeguard. ■ Anchor the Manipulator before turning ON the power to or operating the Manipulator. Turning ON the power to or operating the Manipulator that is not anchored is extremely hazardous and may result in serious bodily injury and/or severe equipment damage to the robot system as the Manipulator may fall down. ■ Before installing and operating the Manipulator, make sure that all parts of the Manipulator are in place and have no external defects. Missing or defective parts may cause improper operation of the Manipulator. Improper operation of the Manipulator is extremely hazardous and may result in serious bodily injury and/or severe equipment damage to the robot system.
 <p>CAUTION</p>	<ul style="list-style-type: none"> ■ The Manipulator must be installed to avoid interference with buildings, structures, utilities, other machines and equipment that may create a trapping hazard or pinch points. ■ Oscillation (resonance) may occur during operation depending on rigidity of the installation table. If the oscillation occurs, improve rigidity of the table or change the speed or acceleration and deceleration settings. ■ Manipulator base has a cooling fan. Install the Manipulator not to seal the cooling fan. (For details, refer to "3.3 Mounting Dimensions")

Protective Tape

Remove the protective tape (4 places).

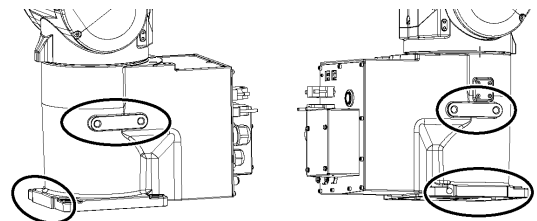

Mounting bolt

For the dimensions, refer to “3.3 Mounting Dimensions”.

There are four threaded holes for the Manipulator base.

Use M12 mounting bolts conforming to the strength equivalent to ISO898-1 property class 10.9 or 12.9.

Tightening torque:

$$100.0 \pm 5.0 \text{ N}\cdot\text{m} \quad (1,020 \pm 51 \text{ kgf}\cdot\text{cm})$$

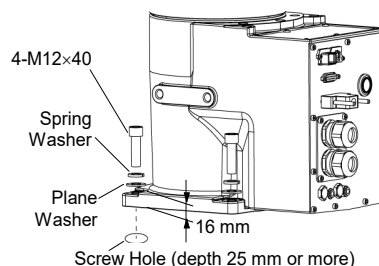

Base table

A base table for anchoring the Manipulator is not supplied. Please make or obtain the base table for your Manipulator. The shape and size of the base table differ depending on the intended use of the robot system. The following is the basic requirements of Manipulator table for your reference.

The base table must not only be able to bear the weight of the Manipulator but also be able to withstand the dynamic movement of the Manipulator when it operates at maximum acceleration/deceleration. Ensure that there is enough strength on the base table by attaching reinforcing materials such as crossbeams.

The torque and reaction force produced by the movement of the Manipulator are as follows:

Max. Horizontal rotating torque	2600 N·m
Max. Horizontal reaction force	1000 N
Max. Vertical rotating torque	3400 N·m
Max. Vertical rotating torque	7900 N

The plate for the Manipulator mounting face should be 30 mm thick or more and made of steel to reduce vibration. The surface roughness of the steel plate should be 25 μm or less.

The base table must be secured on the floor to prevent it from moving.

The Manipulator installation surface should have a flatness of 0.5 mm or less and an inclination of 0.5 ° or less. If the flatness of the installation surface is improper, the base may be damaged or the robot may not fully show its performance.

When using a leveler to adjust the height of the base table, use a screw with M16 diameter or more.

Connector

If you are passing cables through the holes on the base table, see the figures below.
[unit : mm]

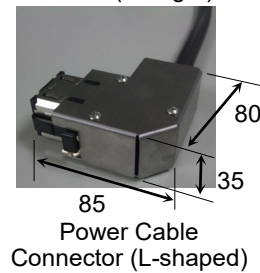
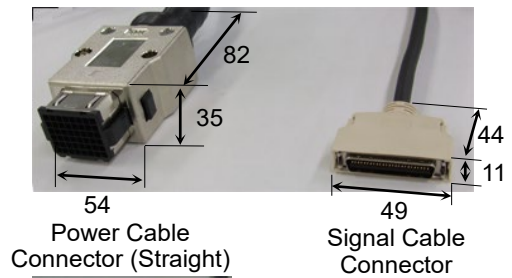
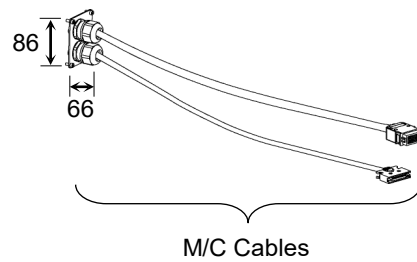

Do not remove the M/C cables from the Manipulator.





For environmental conditions regarding space when placing the Controller on the base table, refer to the Robot Controller manual.

When using the Manipulator in the clean room, follow the steps below before the installation.

- (1) Unpack the Manipulator outside of the clean room.
- (2) Secure the Manipulator to delivery equipment such as a pallet with bolts so that the Manipulator does not fall over.
- (3) Wipe off the dust on the Manipulator with a little alcohol or distilled water on a lint-free cloth.
- (4) Transport the Manipulator into the clean room.
- (5) Secure the Manipulator to the base table.

3.5 Connecting the Cables

 WARNING	<ul style="list-style-type: none"> ■ Before performing any replacement procedure, turn OFF the Controller and related equipment, and then disconnect the power plug from the power source. Performing any replacement procedure with the power ON is extremely hazardous and may result in electric shock and/or malfunction of the robot system. ■ Be sure to connect the AC power cable to a power receptacle. DO NOT connect it directly to a factory power source. To shut off power to the robot system, disconnect the power plug from the power source. Performing any work while connecting the AC power cable to a factory power source is extremely hazardous and may result in electric shock and/or malfunction of the robot system. ■ Be sure to connect the cables properly. Do not allow unnecessary strain on the cables. (Do not put heavy objects on the cables. Do not bend or pull the cables forcibly.) The unnecessary strain on the cables may result in damage to the cables, disconnection, and/or contact failure. Damaged cables, disconnection, or contact failure is extremely hazardous and may result in electric shock and/or improper function of the robot system. ■ Before wiring, turn OFF the Controller and related equipment, and then pull up a warning sign (e.g. DO NOT TURN ON THE POWER.). Wiring with the power ON is extremely hazardous and may result in electric shock and/or malfunction of the robot system. ■ Grounding the Manipulator is done by connecting with the Controller. However, it is recommended to use the grounding hole on the base to ground directly for more secure grounding. If the ground wire is improperly connected to ground, it may result in the fire or electric shock. ■ When connecting / replacing the brake release unit or the external short connector, turn OFF the power to the Controller and the brake release unit. Inserting and removing the connector while the power is ON may result in electrical shock.
--	--

 CAUTION	<ul style="list-style-type: none"> ■ When connecting the Manipulator and the Controller, make sure that the serial numbers on each equipment match. Improper connection between the Manipulator and Controller may not only cause improper function of the robot system but also safety problems. The connection method varies with the Controller used. For details on the connection, refer to the Robot Controller manual. ■ Only authorized or certified personnel should be allowed to perform wiring. Wiring by unauthorized or uncertified personnel may result in bodily injury and/or malfunction of the robot system. ■ If the Manipulator is operated without connecting the brake release unit or the external short connector, the brakes cannot be released and it may cause damage on them. After using the brake release unit, be sure to connect the external short connector to the Manipulator, or check connection of the connector for the brake release unit.
--	--

Cleanroom-model Manipulator

For the Cleanroom-model, an exhaust system is necessary. For details, refer to “Appendix A: Specifications Table”.

M/C Cable Connection method

Connect the power connector and the signal connector of the M/C cables to the Controller.

Grounding

 WARNING	<ul style="list-style-type: none"> ■ Ground resistance must be 100 Ω or less. Improper ground resistance may result in fire and/or electric shock. ■ Do not use the ground line for the Manipulator in common with other ground lines or grounding electrodes for other electric power, motor power, welding devices, etc. Using the ground line for the Manipulator in common with other ground lines or grounding electrodes may result in electric shock and/or malfunction of the robot system. ■ When using metal ducts, metallic conduits, or distributing racks for cable, ground in accordance with national and local electric equipment technical standards. Grounding that does not meet the standards may result in electric shock and/or malfunction of the robot system.
--	---

Follow local regulations for grounding. It is recommended that the core size of the grounding wire be 5.5 mm² or more.

Directly connect the ground line to the Manipulator as shown in the figure below.

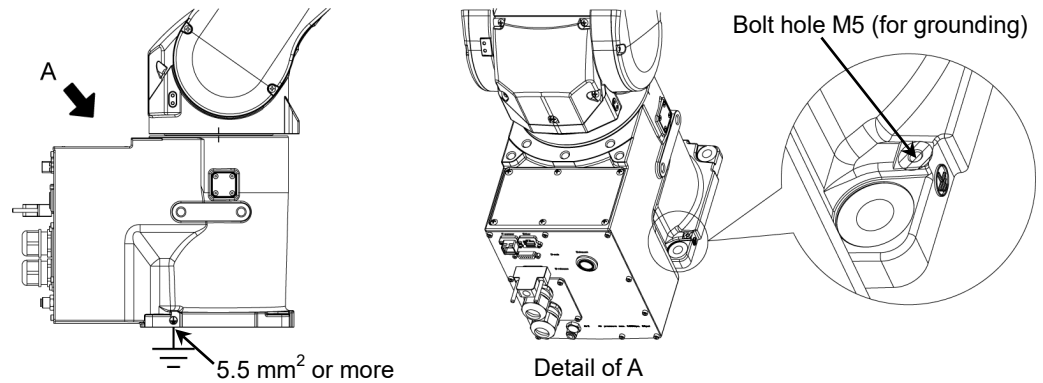

3.6 User Wires and Pneumatic Tubes

 CAUTION	<p>■ Only authorized or certified personnel should be allowed to perform wiring. Wiring by unauthorized or uncertified personnel may result in bodily injury and/or malfunction of the robot system.</p>
---	--

User electrical wires and pneumatic tubes are contained in the cable unit.

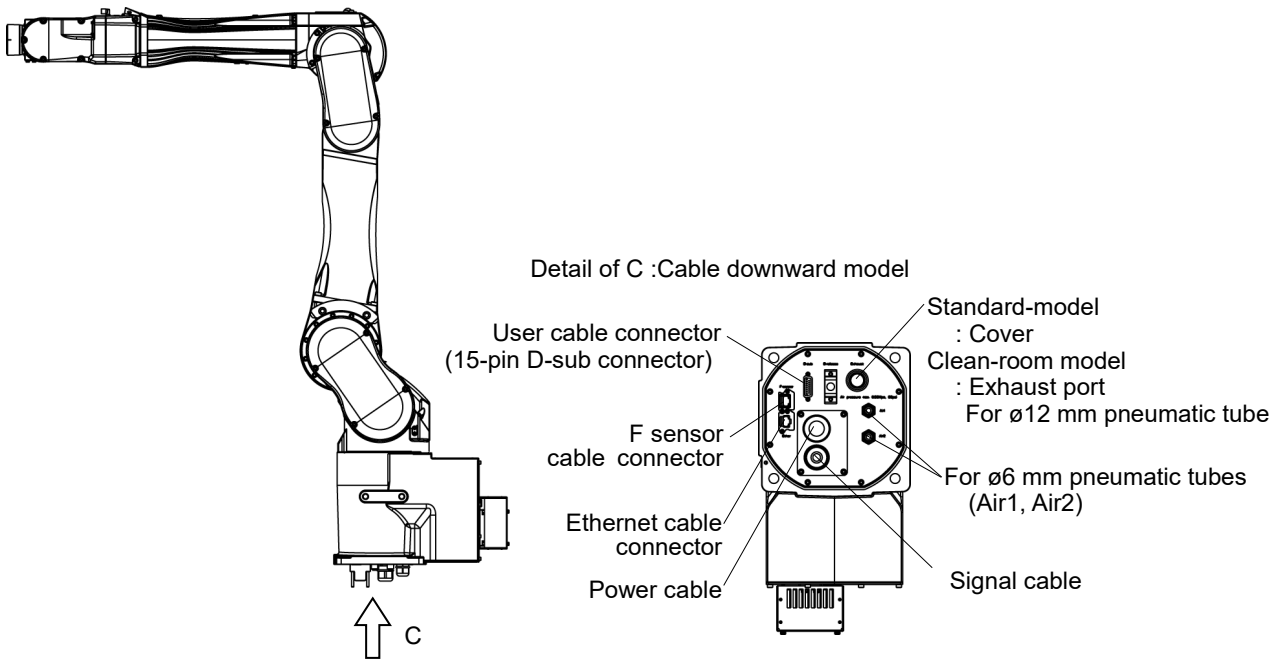
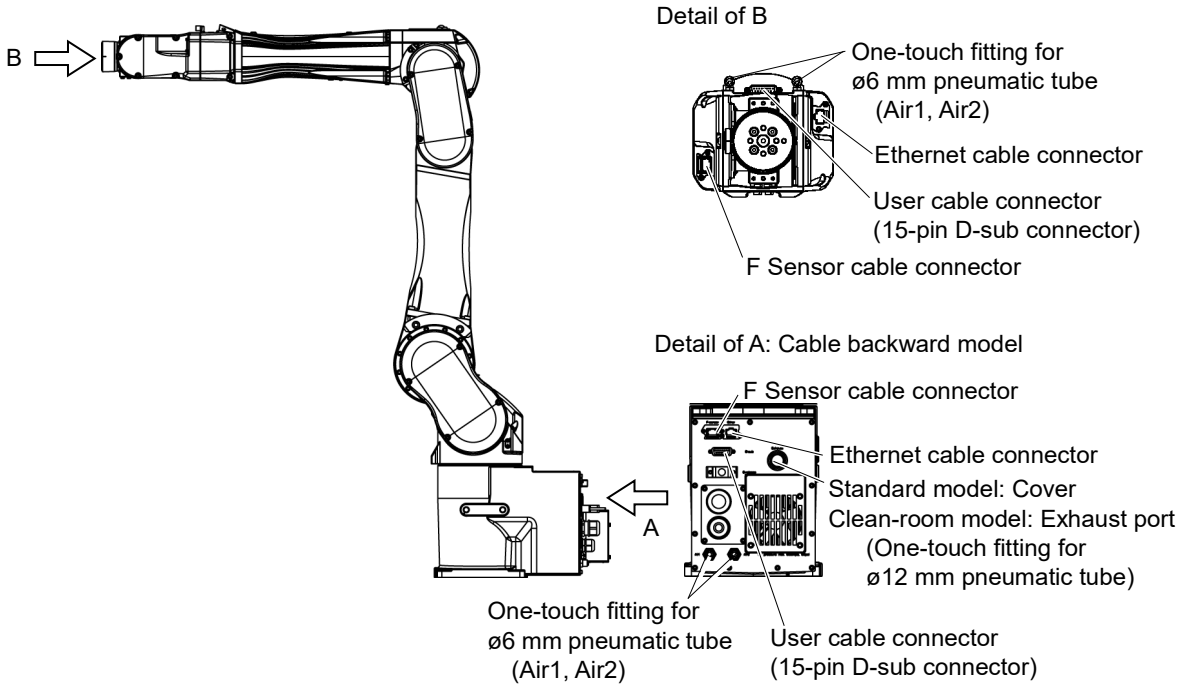

Electrical wires

Specifications of the user wires D-sub 15-pin

Rated Voltage	Allowable Current	Wires	Nominal Sectional Area	Note
AC/DC30 V	1 A	15	0.106 mm ²	Shielded

Pins with the same number, indicated on the connectors on both ends of the cables, are connected.

Attached connector for the user wires (standard-model, cleanroom-model)

		Maker	Standard
15 pin	Connector	JAE	DA-15PF-N (Solder type)
	Clamp Hood	HRS	HDA-CTH(4-40)(10) (Connector setscrew: #4-40 UNC)

Two parts are attached for each

8 pin (RJ45) Cat.5e or equivalent

For the standard and cleanroom model Manipulators, commercially available Ethernet cables can be used.

Other

The 6-pin cable for the F sensor option is included.

Pneumatic tubes

Max. Usable Pneumatic Pressure	Pneumatic Tubes	Outer Diameter × Inner Diameter
0.59 MPa (6 kgf/cm ² : 86 psi)	2	ø6 mm × ø4 mm

The elbow fitting is attached on the Arm #4 at the time of shipment. The part can be replaced with the straight fitting (accessory) according to application.

3.7 Checking the Basic orientation

After installing the Manipulator and setup the operating environment, check if it moves to the basic position properly.

Follow the steps below to set the basic orientation of the Manipulator shown below as the origin position.

- (1) Start Epson RC+.
Double click the [Epson RC+] icon on the desktop.
- (2) Open the command window.
Epson RC+ menu-[Tools]-[Command Window]
- (3) Execute the following command in [Command Window].

```
>Motor On  
>Go Pulse (0,0,0,0,0,0)
```

If the Manipulator cannot be in the basic orientation shown below, please contact the supplier of your region.

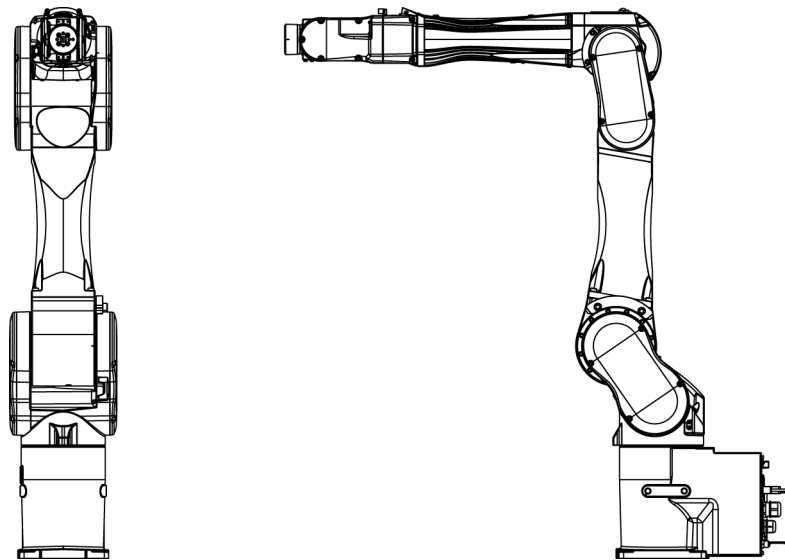

Basic orientation (0 pulse position)

4. End Effectors

4.1 Attaching an End Effector

Create an end effector for your Manipulator. For details of attaching an end effector, refer to “*Hand Function Manual*”

Flange dimensions of the wrist attached to the end of Arm #6 is as below.

 CAUTION	<ul style="list-style-type: none"> ■ If you use an end effector equipped with a gripper or chuck, connect wires and/or pneumatic tubes properly so that the gripper does not release the work piece when the power to the robot system is turned OFF. Improper connection of the wires and/or pneumatic tubes may damage the robot system and/or work piece as the work piece is released when the Emergency Stop switch is pressed. I/O outputs are configured at the factory so that they are automatically shut off (0) by power disconnection, the Emergency Stop switch, or the safety features of the robot system. However, the I/O set in the hand function does not turn off (0) when the Reset command is executed or in emergency stop.
---	---

Wrist Flange

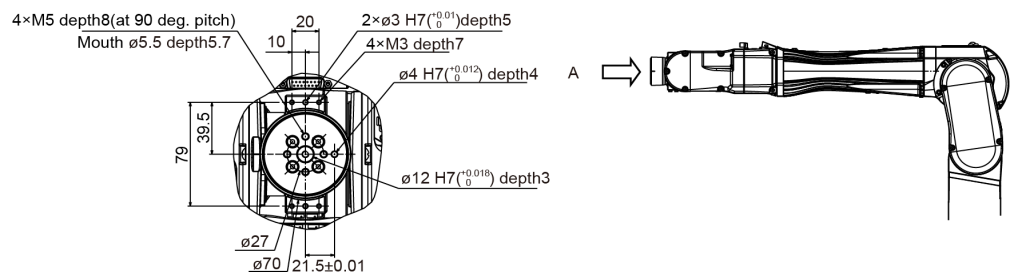

Details from A view

Arm #6

Attach an end effector to the end of the Arm #6 using the M5 bolts.

Layouts

When you operate the Manipulator with an end effector, the end effector may interfere with the Manipulator body depending on the outer diameter of the end effector, the size of the work piece, or the position of the arms. When designing your system layout, pay close attention to the interference area of the end effector.

Compatibility with ISO flange:

To install the end effector whose mounting dimensions are designed for the ISO flange, we provide the optional C8 ISO flange (J6). For details, refer to “6. *Options*”.

4.2 Attaching Camera and Air Valves

Decks are equipped to Arms #3 and #5 to enable the easy installation of air valve.

To mount the camera, the camera plate unit is necessary.

We provide the optional Camera Plate Unit. For details, refer to “6. Options”.

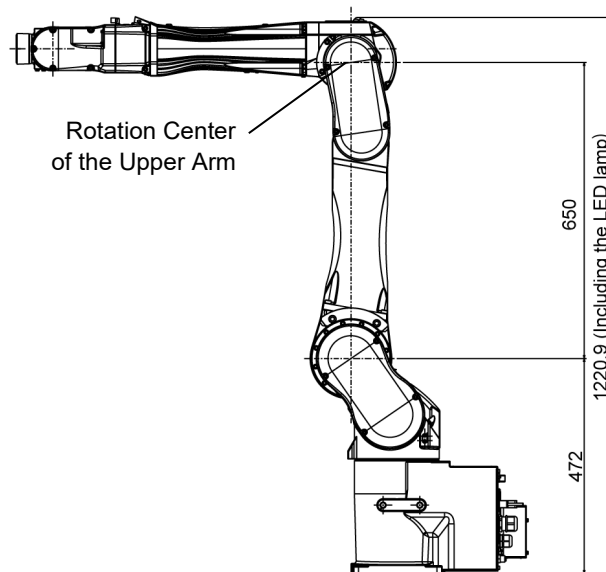
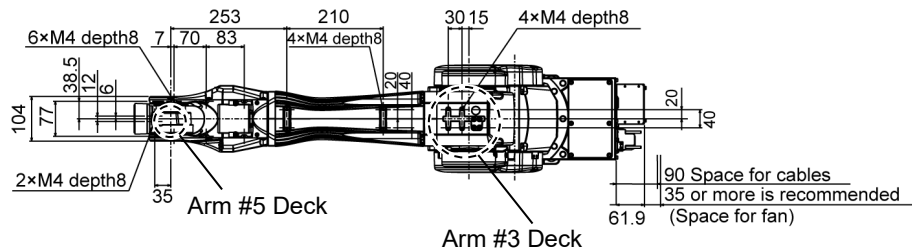

4.3 WEIGHT and INERTIA Settings

The WEIGHT and INERTIA (inertia moment and eccentricity) commands are for setting the load parameters of the Manipulator. These settings optimize the Manipulator motion.

WEIGHT Setting

The WEIGHT command is for setting the load weight. The more the load weight increases, the more the speed and acceleration/deceleration are reduced.

INERTIA Setting

The INERTIA command is for setting the inertia moment and the eccentricity of the load. The more the inertia moment increases, the more the acceleration and deceleration of the Arm #6 are reduced. The more the eccentricity increases, the more the acceleration and deceleration for the Manipulator movement are reduced.

To ensure optimum Manipulator performance, make sure that the load (weight of the end effector and work piece) and inertia moment of the load are within the maximum rating for the Manipulator, and that Arm #6 does not become eccentric.

If the load or the inertia moment exceeds the ratings or if the load becomes eccentric, follow the steps in “4.3.1 WEIGHT Setting” and “4.3.2 INERTIA Setting”, to set parameters.

Setting parameters makes the operation of the Manipulator optimal, reduces vibration to shorten the operating time, and improves the capacity for larger loads. In addition, it reduces persistent vibration produced when the inertia moment of the end effector and work piece is bigger.

You can also set by following “Weight, Inertia, and Eccentricity/offset Measurement Utility”. The following manual describes the details.

Epson RC+ User's Guide

6.18.12 Weight, Inertia, and Eccentricity/offset Measurement Utility

The allowable load for C12 series Manipulators is 12 kg at the maximum.

Due to the limitations of the moment and inertia moment shown in the table below, the load (end effector weight + work piece weight) should also meet these conditions.

Allowable Load

Joint	Allowable Moment	GD ² /4 Allowable Moment of Inertia
#4	25.0 N·m (2.55 kgf·m)	0.70 kg·m ²
#5	25.0 N·m (2.55 kgf·m)	0.70 kg·m ²
#6	9.8 N·m (1.0 kgf·m)	0.20 kg·m ²

Moment

The moment indicates amount of torque applied on the joint in order to support the gravity on the load (end effector + work piece).

The moment increases as weight of the load and amount of eccentricity increase. As this also increases the load applied on the joint, make sure to keep the moment within the allowable value.

Inertia moment

The inertia moment indicates how difficult the load (end effector + work piece) to rotate when the Manipulator joint starts to rotate (amount of inertia). The inertia moment increases as weight of the load and amount of eccentricity increase. As this also increase the load applied on the joint, make sure to keep the inertia moment within the allowable value.

The moment M (Nm) and inertia moment I (kgm²) when the volume of the load (end effector + work piece) is small can be obtained by the following formula.

$$M \text{ (Nm)} = m(\text{kg}) \times L \text{ (m)} \times g \text{ (m/s}^2\text{)}$$

$$I \text{ (kgm}^2\text{)} = m(\text{kg}) \times L^2 \text{ (m)}$$

m : Weight of load (kg)

L : Eccentric quantity of load (m)

g : Gravitational acceleration (m/s²)

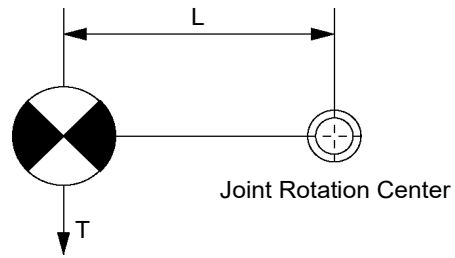

The figure below shows distribution of the center of gravity when the volume of the load (end effector + work piece) is small.

Design the end effector so that the center of gravity is within the allowable moment.

If the volume of the load is large, calculate the moment and inertia moment by referring to “4.3.2 INERTIA setting” - “Calculating the Inertia Moment”.

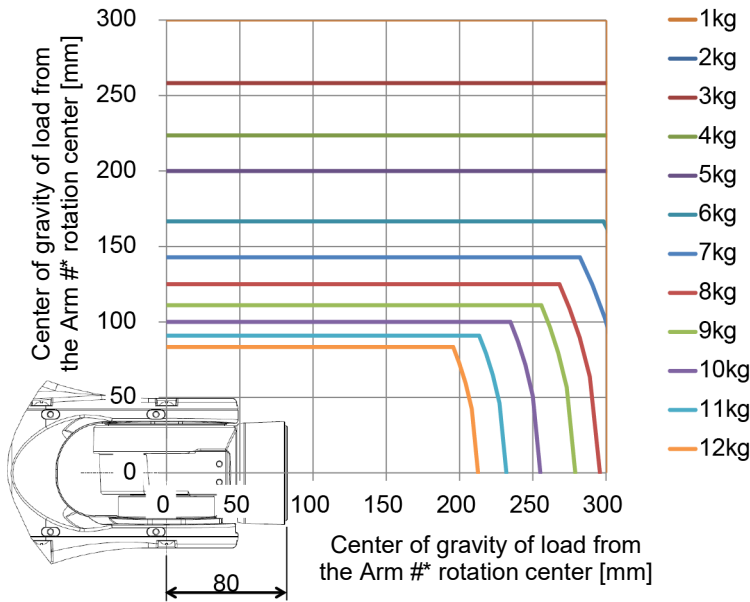

Max. Eccentric Quantity of Load

(Distance between the joint rotation center and the load's center of gravity)

Joint	1 kg	3 kg	5 kg	8 kg	10 kg	12 kg
#4	300 mm	300 mm	300 mm	296 mm	255 mm	213 mm
#5	300 mm	300 mm	300 mm	296 mm	255 mm	213 mm
#6	300 mm	258 mm	200 mm	125 mm	100 mm	83 mm

When calculating the critical dimension of the load using the allowable moment and inertia moment, the calculated value represents a distance from the Arm #6 rotation center, not the distance from the flange. To calculate the distance from the flange to the load's center of gravity, subtract the distance from the center of the Arm #5 rotation center to the flange (=80 mm) as shown in the example below.

Example: Calculation of the critical dimension of the load (a) when the load is 12 kg.

Center of gravity by the allowable moment control:

$$25.0 \text{ Nm} / (12 \text{ kg} \times 9.8 \text{ m/s}^2) = 0.212 \text{ m} = 212 \text{ mm}$$

Center of gravity by the allowable inertia moment control:

$$(0.47 \text{ kgm}^2 / 12 \text{ kg})^{1/2} = 0.241 \text{ m} = 241 \text{ mm}$$

Due to the allowable moment control, center of gravity for the load limit is 212 mm from the Arm #5 rotation center.

Distance from the flange to the center of gravity for the load limit

$$a = 212 \text{ mm} - 80 \text{ mm} = 132 \text{ mm}$$

Critical Dimension of Load

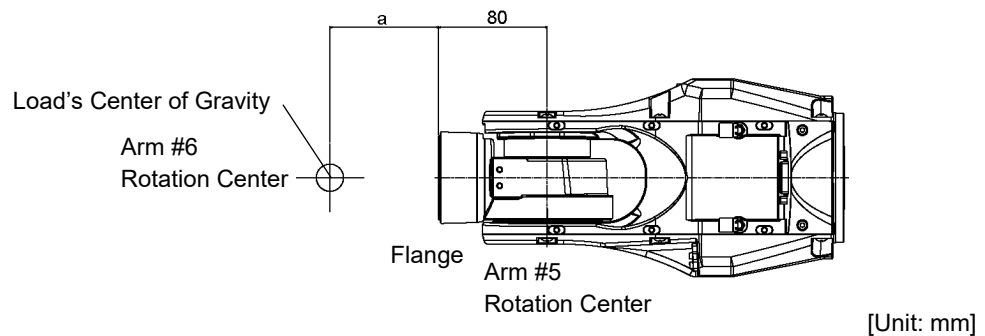

4.3.1 WEIGHT setting

 CAUTION	<ul style="list-style-type: none"> Set the total weight of the end effector and the work piece smaller than the maximum payload. The C12 series Manipulators can operate without limitations on the condition unless and until the load exceeds this maximum payload. Always set the Weight parameters of the WEIGHT command according to the load. Setting a value that is smaller than the actual load may cause errors, excessive shock, insufficient function of the Manipulator, and/or shorten the life cycle of parts/mechanisms.
---	---

The acceptable weight capacity (end effector and work piece) for C12 series Manipulators is as follows:

Rated	Maximum
3 kg	12 kg

Change the setting of the Weight parameter according to the load.

After changing the Weight parameter setting, the maximum acceleration/deceleration and speed of the robot system corresponding to the load is set automatically.

Setting method of Weight parameters

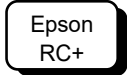

Select [Tools]-[Robot Manager]-[Weight] panel and set the value in [Weight:].
 You may also execute the Weight command from [Command Window].

Load on the Manipulator Mounting location of the load

Load on the fore end of Arm #6

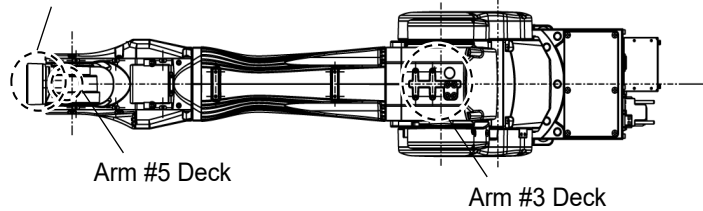

Details of the deck

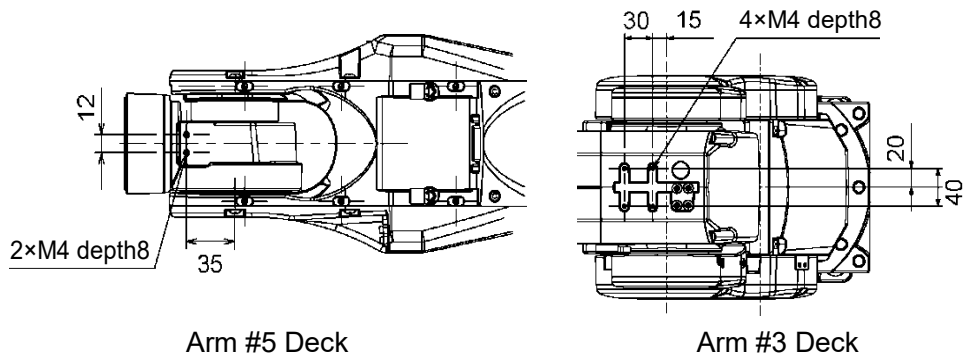

[Unit: mm]

When you attach the equipment to the decks on the upper arm, convert its weight into equivalent weight assuming that the equipment is attached to the end of the Arm #6. Then, this equivalent weight added to the load will be a Weight parameter.

Calculate the Weight parameter by using the formula below and enter the value.

Weight Parameter Formula

$$\text{Weight parameter} = M_w + W_a + W_b$$

M_w : Load on the fore end of Arm #6 (kg)

W_a : Equivalent weight of the Arm #3 deck (kg)

W_b : Equivalent weight of the Arm #5 deck (kg)

$$W_a = M_a (L_a)^2 / (L)^2$$

$$W_b = M_b (L_b)^2 / (L)^2$$

M_a : Weight of the air valve on the Arm #3 deck

M_b : Weight of the camera on the Arm #5 deck

L : Length of the upper arm (315 mm)

L_a : Distance between the Joint #3 and the center of gravity of the air valve on the Arm #3 deck (mm)

L_b : Distance between the Joint #3 and the center of gravity of the camera on the Arm #5 deck (mm)

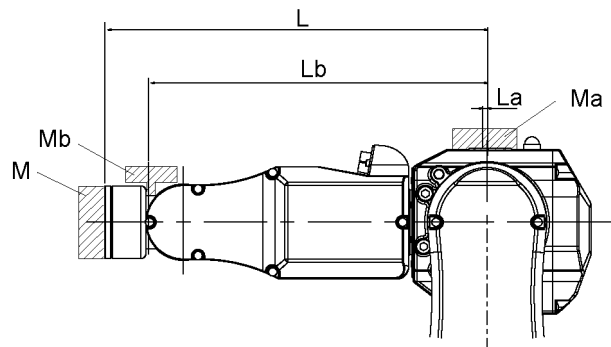

<Example> The fore end of the Arm #6 is 730 mm (L) away from the Joint #3 of C12-A1401** (C12XL).

Load on the fore-end of Arm #6 is 5 kg (M_w).

Load on the Arm #3 deck is 1.5 kg (M_a).

The deck is 0 mm (L_a) away from Joint #3.

Load on the Arm #5 deck is 1.0 kg (M_b).

The deck is 690 mm (L_b) away from the Joint #3.

$$W_a = 1.5 \times 0^2 / 730^2 = 0$$

$$W_b = 1.0 \times 690^2 / 730^2 = 0.89 \rightarrow 0.9 \text{ (round up)}$$

$$M_w + W_a + W_b = 5 + 0 + 0.9 = 5.9$$

Enter "5.9" for the Weight parameter.

Automatic speed setting by Weight parameter

The percentages in the graphs are based on the speed at rated weight (3 kg) as 100%.

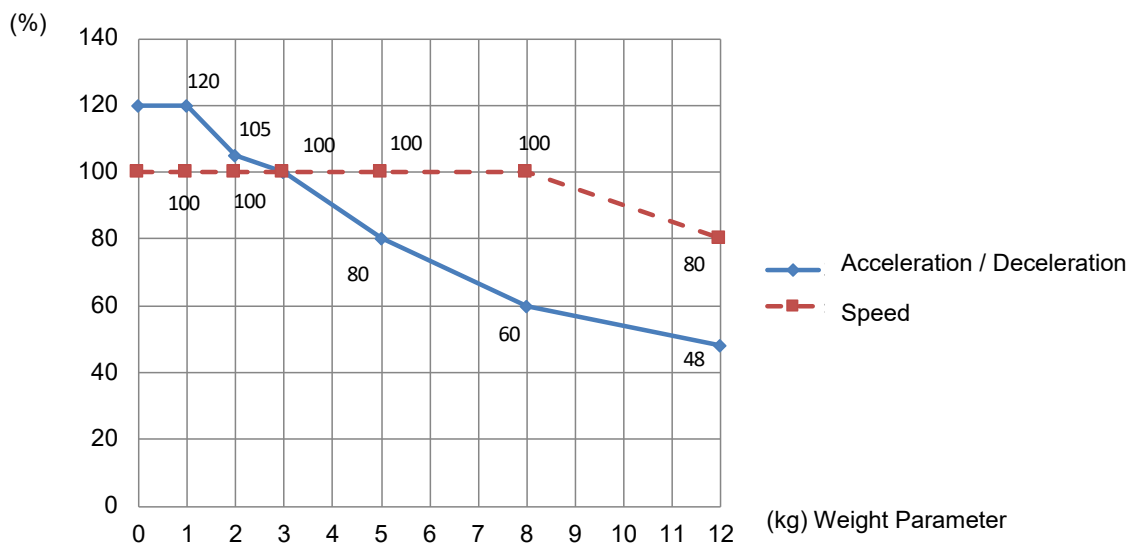

NOTE Maximum AccelS setting value varies depending on Weight setting value. For more details, refer to “Appendix A: Specifications Table”.

4.3.2 INERTIA setting

Inertia Moment and the INERTIA Setting

The inertia moment is defined as “the ratio of the torque applied to a rigid body and its resistance to motion”. This value is typically referred to as “the moment of inertia”, “inertia”, or “GD²”. When the Manipulator operates with objects such as an end effector attached to the Arm #6, the moment of inertia of load must be considered.

 CAUTION	<ul style="list-style-type: none"> The inertia moment of the load (weight of the end effector and work piece) must be 0.2 kg·m² or less. The C12 series Manipulators are not designed to work with inertia moment exceeding 0.2 kg·m². Always set the inertia moment (INERTIA) parameter according to the inertia moment. Setting a value that is smaller than the actual inertia moment may cause errors, excessive shock, insufficient function of the Manipulator, and/or shorten the life of parts/mechanisms.
---	---

The acceptable inertia moment of load for C12 series Manipulators is 0.03 kg·m² nominal rating and 0.2 kg·m² maximum. Change the setting of the inertia moment according to the inertia moment of the load using the INERTIA command. After the setting has been changed, the maximum acceleration/deceleration speed of Arm #6 responding to “inertia moment” is set automatically.

Inertia moment of load on Arm #6

The inertia moment of the load (weight of the end effector and work piece) on the Arm #6 can be set by the “inertia moment (INERTIA)” parameter of the INERTIA command.

Epson RC+ Select [Tools]–[Robot Manager]–[Inertia] panel and enter the value in [Load inertia:]. You may also execute the Inertia command from [Command Window].

Eccentric Quantity and the INERTIA Setting



- The eccentric quantity of the load (weight of the end effector and work piece) must be 300 mm or less. The C12 series Manipulators are not designed to work with eccentric quantity exceeding 300 mm. Always set the eccentric quantity parameter according to the eccentric quantity. Setting a value that is smaller than the actual eccentric quantity may cause errors, excessive shock, insufficient function of the Manipulator, and/or shorten the life cycle of parts/mechanisms.

The acceptable eccentric quantity of the load for C12 series Manipulators is 50 mm at nominal rating and 300 mm at maximum. When the eccentric quantity of the load exceeds the rating, change the setting of eccentric quantity parameter using the INERTIA command. After changing the setting, the maximum acceleration/deceleration speed of Manipulator corresponding to “eccentric quantity” is set automatically.

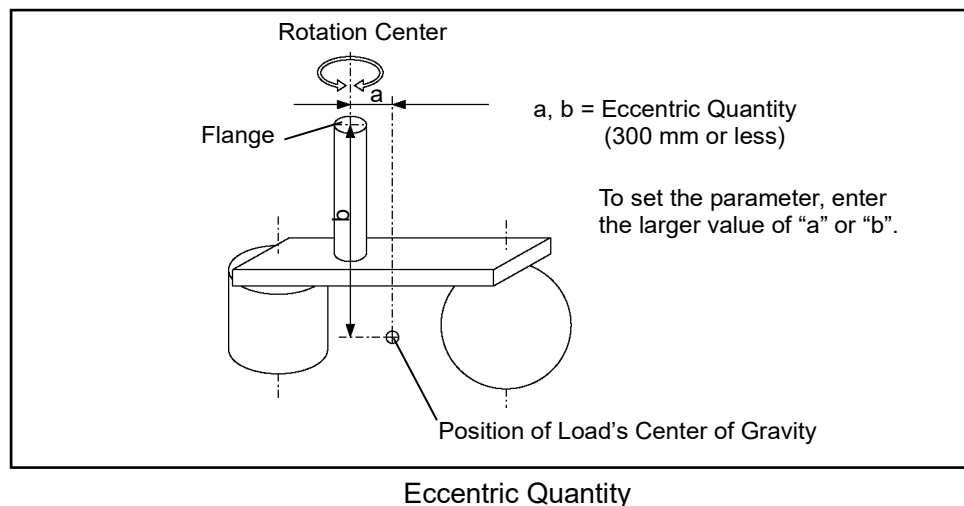

Eccentric quantity of load on Arm #6

The eccentric quantity of the load (weight of the end effector and work piece) on the Arm #6 can be set by the “eccentric quantity” parameter of the INERTIA command. Enter the larger value of either “a” or “b” in the figure above to [Eccentricity].



Select [Tools]–[Robot Manager]–[Inertia] panel and enter the value into [Eccentricity:]. You may also execute the Inertia command from [Command Window].

Automatic acceleration/deceleration setting by INERTIA (eccentric quantity)

Automatic setting by inertia moment setting

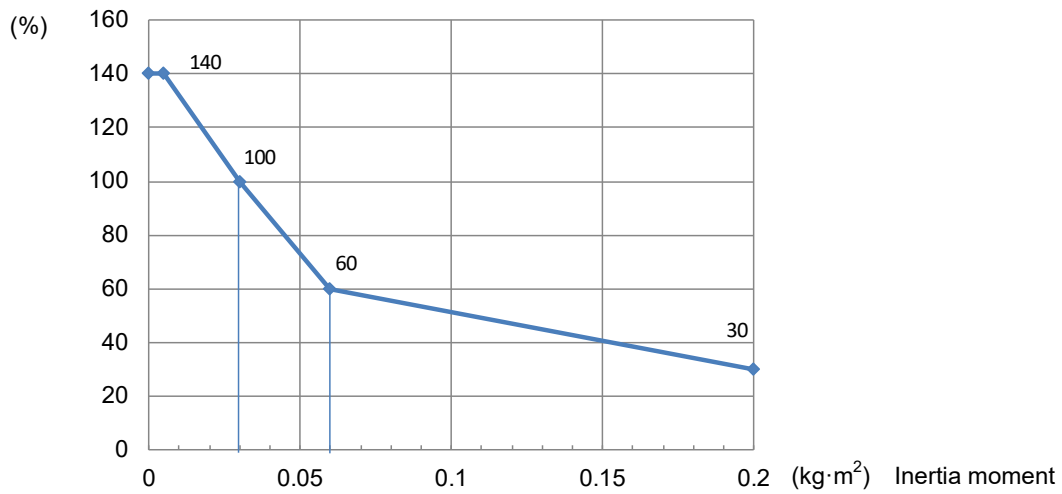

* The percentage in the graph is based on the acceleration/ deceleration at rated eccentricity (0.03 kg·m²) as 100%.

Automatic setting by eccentricity setting

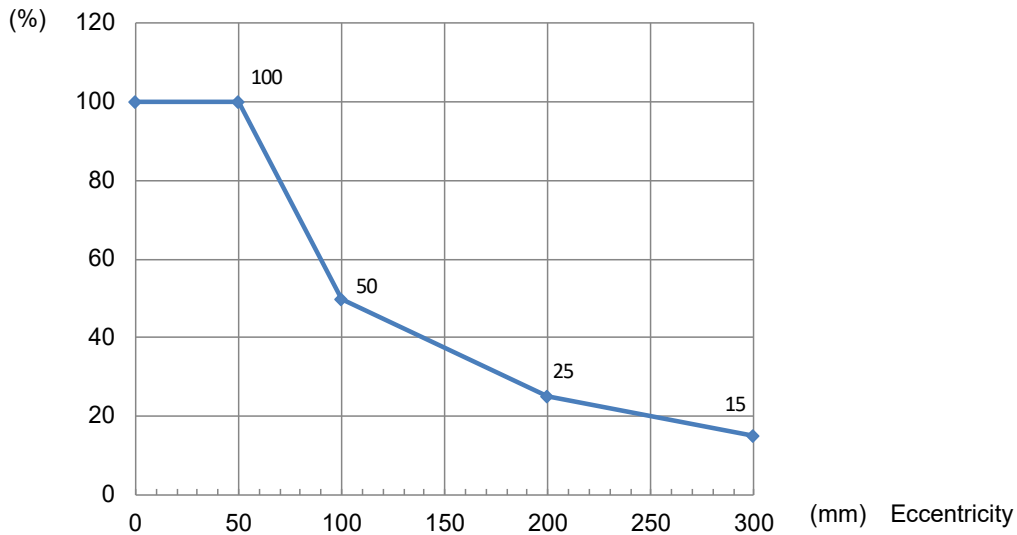

* The percentage in the graph is based on the acceleration/ deceleration at rated eccentricity (50 mm) as 100%.

Calculating the Inertia Moment

Refer to the following example formulas to calculate the inertia moment of the load (end effector with work piece).

The inertia moment of the entire load is calculated by the sum of (a), (b), and (c).

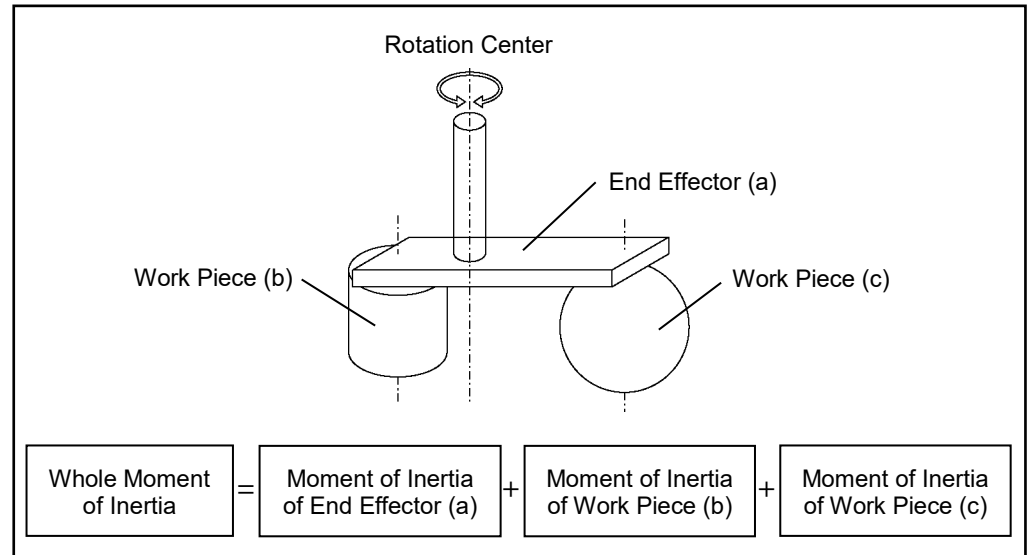

The methods for calculating the inertia moment for (a), (b), and (c) are shown in this and the next page. Figure out the whole inertia moment using the basic formulas below.

(a) Inertia moment of a rectangular parallelepiped

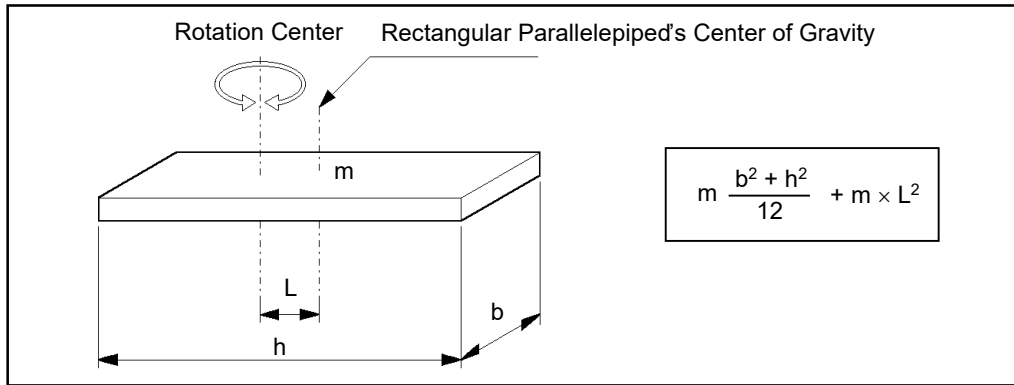

(b) Inertia moment of a cylinder

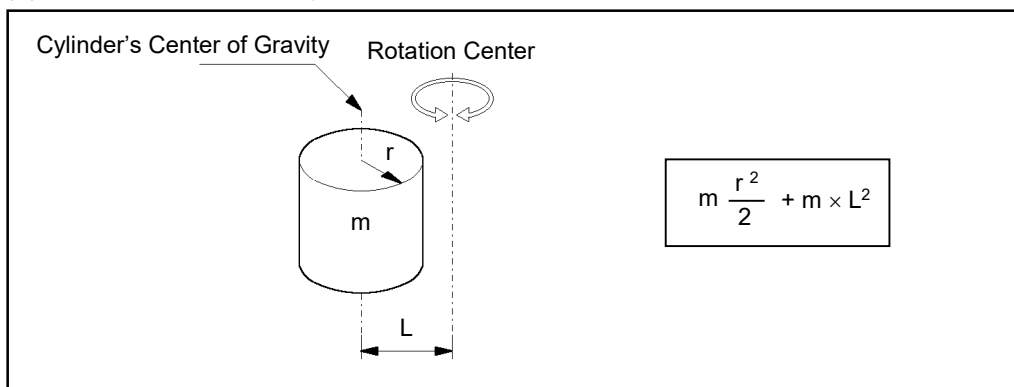

(c) Inertia moment of a sphere

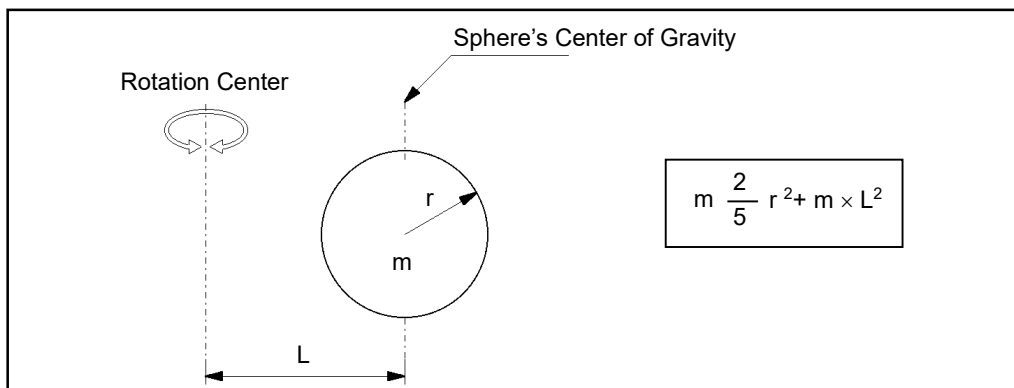

4.4 Precautions for Auto Acceleration/Deceleration

The speed and acceleration/deceleration of the Manipulator motion are automatically optimized according to the values of WEIGHT and INERTIA and the Manipulator's postures.

WEIGHT Setting

The speed and acceleration/deceleration of the Manipulator are controlled according to the load weight set by the WEIGHT command.

The more the load weight increases, the more the speed and acceleration/deceleration are reduced to prevent residual vibration.

INERTIA Setting

The acceleration/deceleration of Arm #6 are controlled according to the inertia moment set by the INERTIA command. The acceleration/deceleration of the whole Manipulator are controlled according to the eccentricity set by the INERTIA command. The more the inertia moment and eccentricity of the load increase, the more the acceleration/deceleration are reduced.

Auto Acceleration/Deceleration According to Manipulator's Posture

The acceleration/deceleration are controlled according to the Manipulator's posture. When the Manipulator extends its arms or when the movement of the Manipulator produces vibration frequently, the acceleration/deceleration are reduced.

Set appropriate values for WEIGHT and INERTIA so that the Manipulator operation is optimized.

5. Motion Range



- When limiting the motion range for safety, be sure to set by both the pulse range and mechanical stops. Failure to do so may cause serious safety problems.

The motion range is preset at the factory as describes in “2.5 Standard Motion Range”. This is the maximum motion range of the Manipulator.

Motion range is set by the following three methods:

1. Setting by pulse range (for all arms)
2. Setting by mechanical stops
3. Setting the Cartesian (rectangular) range in the X, Y coordinate system of the Manipulator

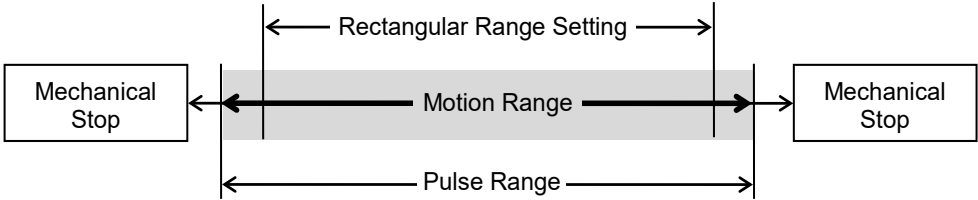

When the motion range is changed due to layout efficiency or safety, follow the descriptions in 5.1 through 5.4 to set the range.

5.1 Motion Range Setting by Pulse Range (for Each Joint)

Pulses are the basic unit of Manipulator motion. The motion range of the Manipulator is controlled by the pulse range (the lower limit and the upper limit) of each axis. Pulse values are read from the encoder output of the servo motor. The pulse range should be set within the mechanical stop range.

NOTE The Arms #1 and #4 do not have a mechanical stop.

NOTE Once the Manipulator receives an operating command, it checks whether the target position specified by the command is within the pulse range before operating. If the target position is out of the set pulse range, an error occurs and the Manipulator does not move.

Epson RC+ The pulse range can be set in [Tools]-[Robot manager]-[Range] panel. You may also execute the Range command from the [Command Window].

5.1.1 Max. Pulse Range of Joint #1

Pulse values in counterclockwise direction are positive (+) and values in clockwise direction are negative (-).

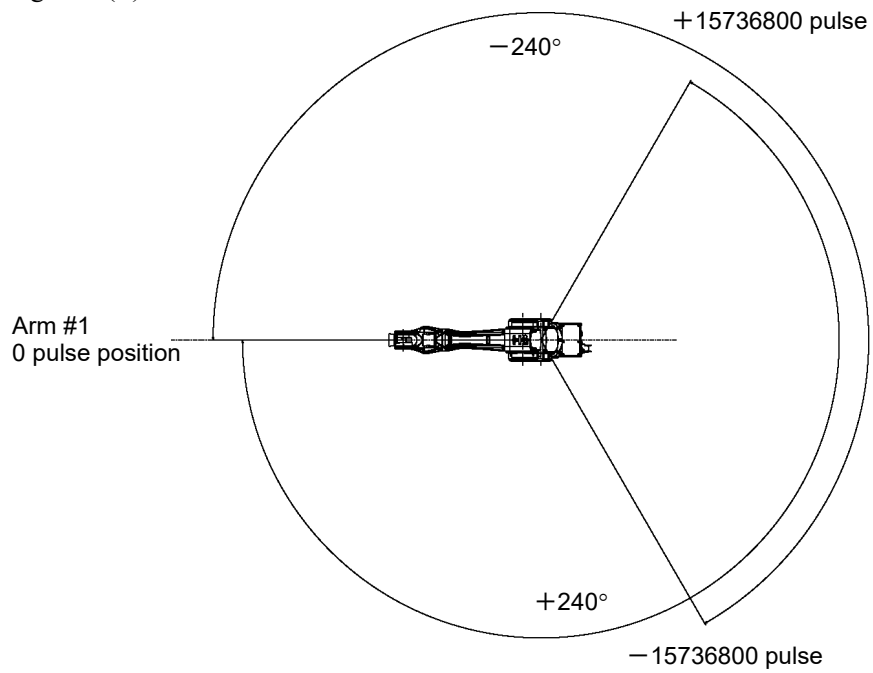

5.1.2 Max. Pulse Range of Joint #2

Pulse values in clockwise direction are positive (+) and values in counterclockwise direction are negative (-).

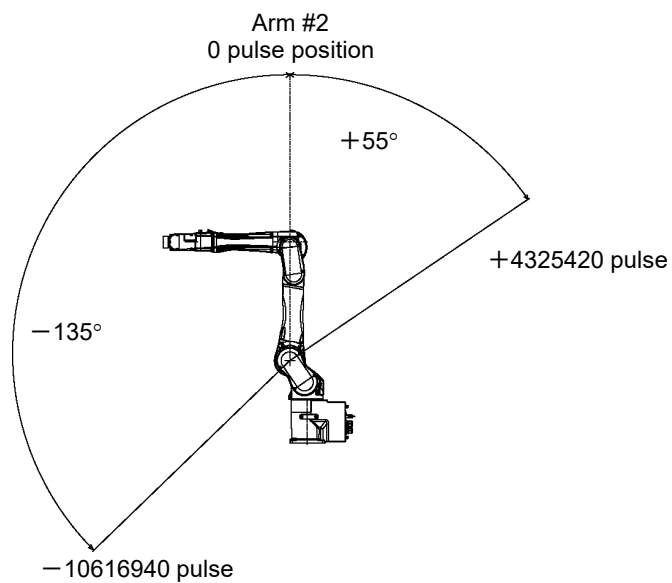

5.1.3 Max. Pulse Range of Joint #3

Pulse values in clockwise direction are positive (+) and values in counterclockwise direction are negative (-).

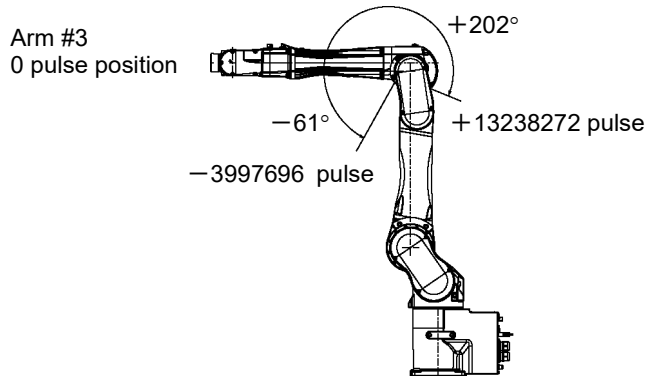

5.1.4 Max. Pulse Range of Joint #4

From the angle of arm end, clockwise pulse values are positive (+) and counterclockwise pulse values are negative (-).

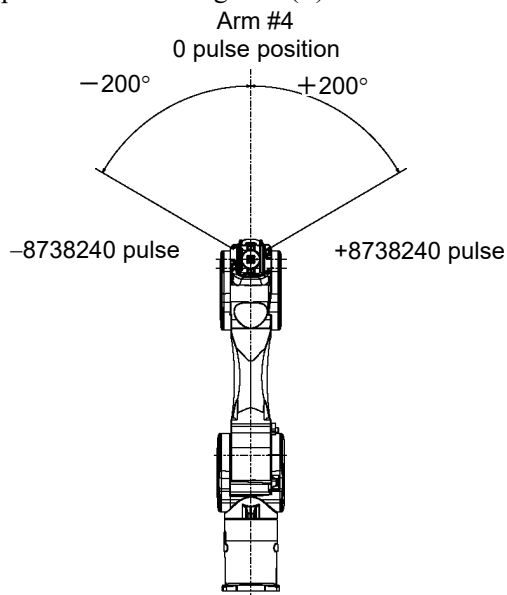

5.1.5 Max. Pulse Range of Joint #5

Pulse values in clockwise direction are positive (+) and values in counterclockwise direction are negative (-).

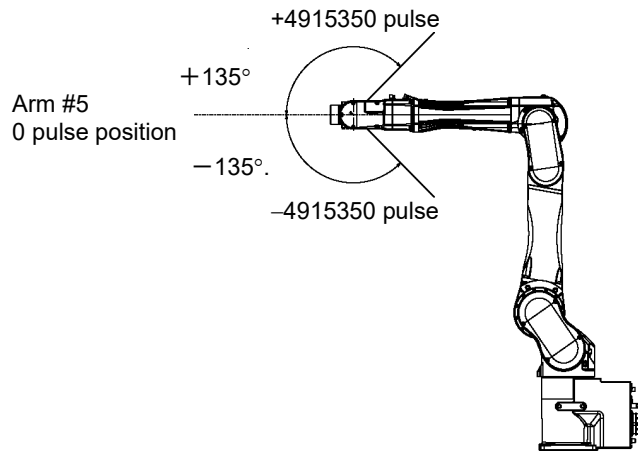

5.1.6 Max. Pulse Range of Joint #6

From the angle of arm end, clockwise pulse values are positive (+) and counterclockwise pulse values are negative (-).

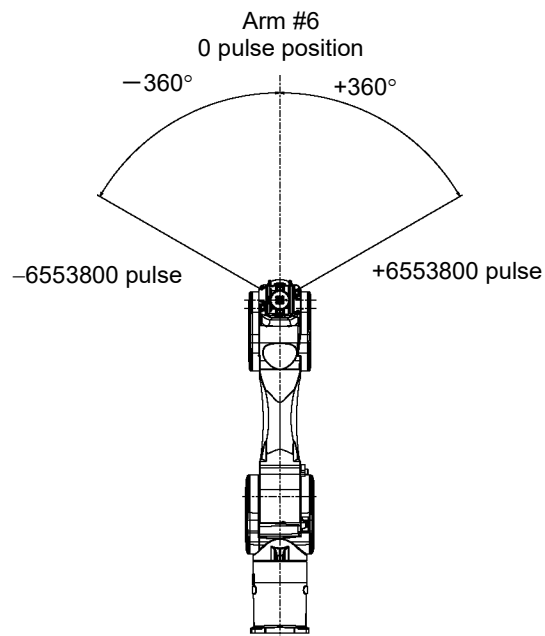

5.2 Motion Range Setting by Mechanical Stops

Using the adjustable mechanical stops physically limits the absolute area that the Manipulator can move.

Be sure to turn OFF the Manipulator in advance.

Use bolts conforming to the specified length and surface processing (ex: nickel plating) with high corrosion resistance.

Specify the pulse range again after changing the position of the mechanical stop.

For details on the pulse range setting, refer to “5.1 Motion Range Setting by Pulse Range (for All Arms)”.

Be sure to set the pulse range not to exceed the setting angles of the mechanical stop.

5.2.1 Motion Range Setting of Joint #1

Install the adjustable mechanical stop (J1) to the threaded hole corresponding to the angle you want to set.

Normally the mechanical stop is not installed.

Hexagon socket head cap bolt M12×30×2 bolts
 Strength Equivalent to ISO898-1 property class 10.9 or 12.9
 Tightening torque 42.0 ± 2.1N·m (428 ± 21 kgf·cm)

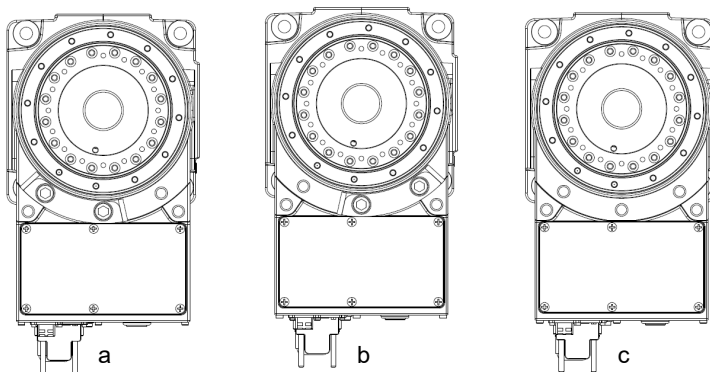

	a	b	c
Angle (°)	-145, +110	-110, +145	±240
Pulse (pulse)	-9507650 +7212700	-7212700 +9507650	±15736800
Adjustable mechanical stop (J1)	Applied	Applied	Not applied (standard)

5.2.2 Motion Range Setting of Joint #2

Remove the mechanical stop installed as standard and install the adjustable mechanical stop (J2). (Joint #2 standard motion range -135° to $+55^{\circ}$)

Hexagon socket head cap bolt	M10×35×2 bolts
Strength	Equivalent to ISO898-1 property class 10.9 or 12.9
Tightening torque	$32.0 \pm 1.6 \text{ N}\cdot\text{m}$ ($326 \pm 16 \text{ kgf}\cdot\text{cm}$)

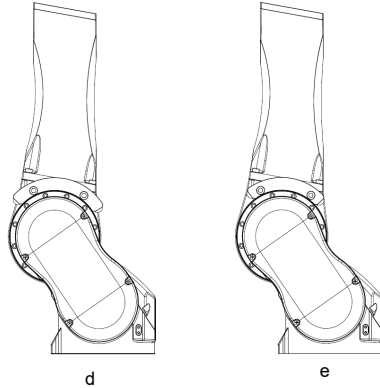

	d	e
Angle ($^{\circ}$)	$-125, +45$	$-135, +55$
Pulse(pulse)	-9830500 $+3538980$	-10616940 $+4325420$
Adjustable mechanical stop (J2)	Applied	Applied (standard)

5.2.3 Motion Range Setting of Joint #3

Remove the mechanical stop installed as standard and install the adjustable mechanical stop (J3). (Joint #3 standard motion range -61° to $+202^{\circ}$)

Hexagon socket head cap bolt	M6×15×2 bolts
Strength	Equivalent to ISO898-1 property class 10.9 or 12.9
Tightening torque	$13.0 \pm 0.6 \text{ N}\cdot\text{m}$ ($133 \pm 6 \text{ kgf}\cdot\text{cm}$)

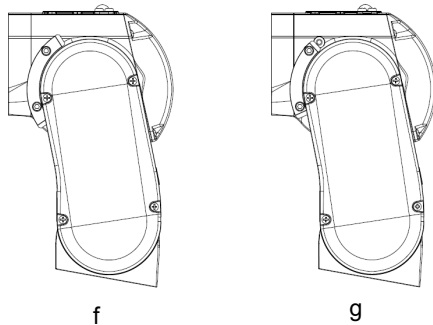

	f	g
Angle ($^{\circ}$)	$-51, +192$	$-61, +202$
Pulse(pulse)	-3342336 $+12582912$	-3997696 $+13238272$
Adjustable mechanical stop (J3)	Applied	Applied (standard)

5.3 Restriction of Manipulator Operation by Joint Angle Combination

To prevent the arms of the Manipulator from interfering each other, the Manipulator operation is restricted in the specified motion range according to the joint angle combination of the Arm #1, #2, and #3.

The Manipulator operation is restricted and the Manipulator stops when the joint angles of the Arm are within the colored area in the following figures.

The restriction to Manipulator operation is enabled:

- During CP motion command execution
- When you attempt to execute the motion command for moving the Manipulator to a target point (or pose) in the specified motion range.

The restriction to the Manipulator operation is disabled:

- The Arms of the Manipulator momentarily go through the specified motion range during the PTP motion command execution even though the joint angles of the Arms are in the colored area of the figures above.

Combination of Joint #2 and #3

$$-110^\circ \leq J1 \leq 110^\circ$$

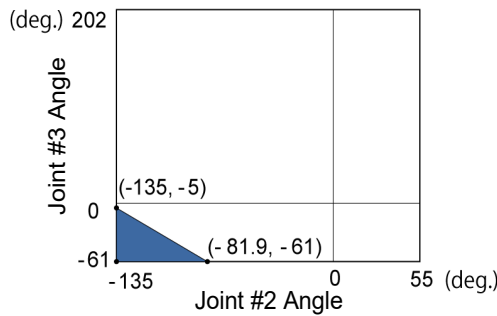

$$-140^\circ < J1 < -110^\circ \quad \text{or} \quad 110^\circ < J1 < 140^\circ$$

$$-240^\circ < J1 < -220^\circ \quad \text{or} \quad 220^\circ < J1 < 240^\circ$$

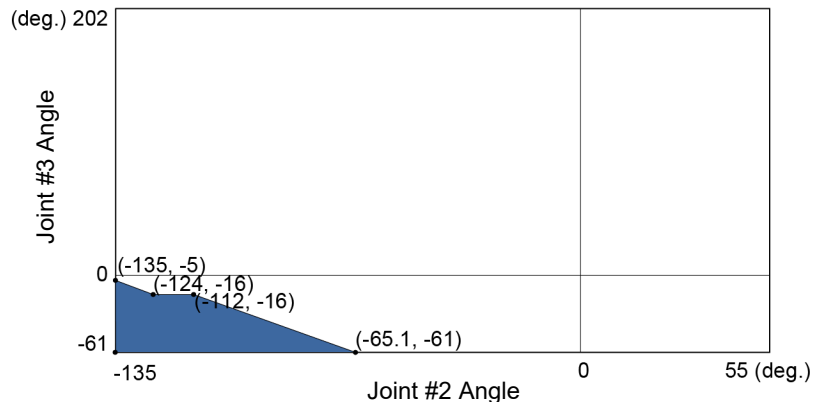

$$-220^{\circ} \leq J1 \leq -140^{\circ} \quad \text{or} \quad 140^{\circ} < J1 < 220^{\circ}$$

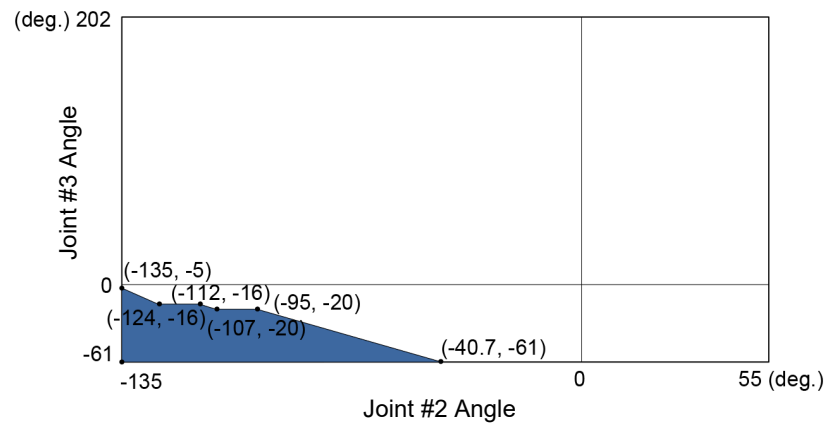

5.4 Coordinate System

The origin point is where the Manipulator's installation face intersects with the rotation axis of Joint #1.

For details on the coordinate system, refer to the *Epson RC+ Users Guide manual*.

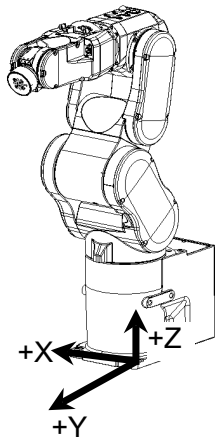

5.5 Changing the Robot

This section describes how to change the Manipulator model on Epson RC+.



CAUTION

- Changing the Manipulator should be done with great caution. It initializes the robot calibration parameters (Hofs, CalPIs), additional axis information, and PG parameter data.

Before changing the robot, make sure to save the calibration data by following the procedure below.

1. Select the Epson RC+ menu-[Setup]-[System Configuration].
2. Select [Controller]- [Robots]-[Robot**]-[Calibration] from the tree list. Then, click [Save].

- (1) Select the Epson RC+ menu-[Setup]-[System Configuration].
- (2) Select [Controller]- [Robots]-[Robot**] from the tree list. (Dialog image: Epson RC+ 8.0)

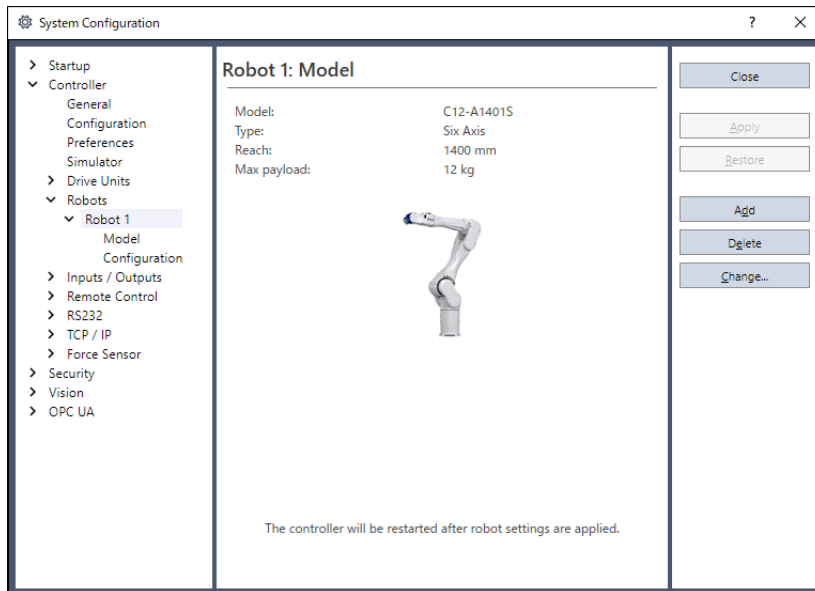

- (3) Click the [Change...] button.
- (4) The following dialog box will be displayed.
 Input the robot name and serial number printed on the Signature label of the Manipulator. Any serial number can be entered. However, enter the number printed on the Signature label.

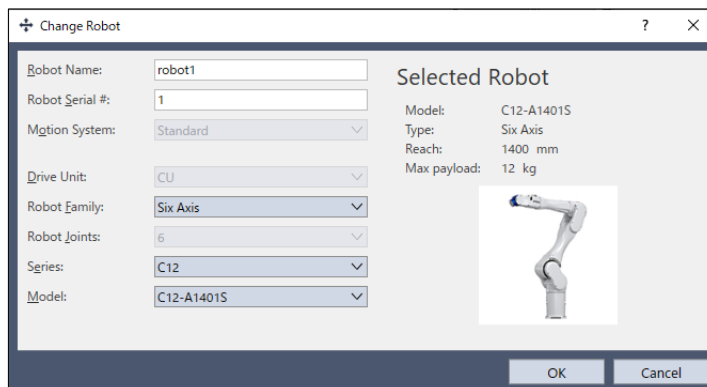

- (5) Select the robot type in the [Robot type] box.
- (6) Select the series name of the Manipulator in the [Series] box.
- (7) Select the robot model in the [Model] box. Available robots will be displayed according to the format of the currently installed motor driver. When [Dry run] is used, all the Manipulators of the series selected in Step 6 will be displayed.
- (8) Click the [OK] button. The Controller will be restarted.

5.6 Setting the Cartesian (Rectangular) Range in the XY Coordinate System of the Manipulator

The Cartesian (rectangular) range in the XY coordinate system of the Manipulator is specified by the limited Manipulator operation area and the XYLIM setting.

The limited Manipulator operation area is defined so that the end effector does not interfere with the rear side of the Manipulator. The XYLIM setting that you can determine the upper and lower limits of the X and Y coordinates.

The limited Manipulator operation area and the XYLIM setting apply only to the software. Therefore, these settings do not change the physical range. The maximum physical range is based on the position of the mechanical stops.

These settings are disabled during a joint jogging operation. Therefore, be careful not to allow the end effector to collide with the Manipulator or peripheral equipment.

The method for changing the XYLIM setting varies with the software used.

Epson
RC+

Set the XYLIM setting in [Tools]-[Robot manager]-[XYZ Limits] panel.
You may also execute the XYLim command from the [Command Window].

6. Options

C12 series Manipulator has the following options.

- 6.1 Brake Release Unit
- 6.2 Camera Plate Unit
- 6.3 Tool Adapter (ISO flange)
- 6.4 Adjustable Mechanical Stops
- 6.5 User Wires and Pneumatic Tubes

6.1 Brake Release Unit

With the electromagnetic brake is ON (such as in Emergency Stop status), all arms don't move.

You can move the Arms by hand using the brake release unit while the Controller power is OFF or right after unpacking.

 WARNING	<ul style="list-style-type: none"> ■ When connecting / replacing the brake release unit or the external short connector, turn OFF the power to the Controller and the brake release unit. Inserting and removing the connector while the power is ON may result in electrical shock.
--	---

 CAUTION	<ul style="list-style-type: none"> ■ Normally, release the brake of joints one by one. Take extra care if you need to release the brakes of two or more joints simultaneously. Releasing the brakes of two or more joints simultaneously may cause hands and fingers to be caught and/or equipment damage to or malfunction of the Manipulator as the arms of the Manipulator may move in unexpected directions. ■ After releasing the brake, the arm may fall by its own weight or move to the unexpected direction. Make sure to prepare a countermeasure to prevent the arm from falling and check the operation environment is safe.
--	--

Width	180 mm
Depth	150 mm
Height	87 mm
Weight (Cables are not included.)	1.7 kg
Cable to the Manipulator	2 m
M/C Short connector	For M/C power cable short-circuit

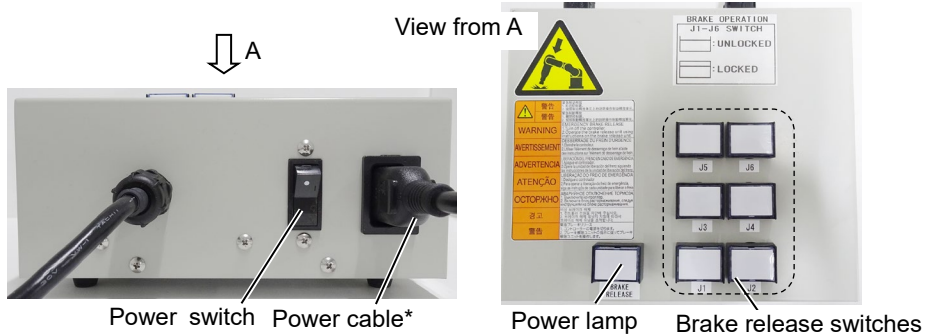

* Item you should provide

Power Cable

You must provide a power cable.

The power cable is required to meet the specifications below.

Item	Specification
(1) Plug	Comply with local safety regulation - Class I (2P+PE), AC250V, 6A or 10A Ex.: CEE Pub.7 Certified, CCC Certified, KC Certified, BS1363 Certified, PSB Certified, BIS Certified, SABS Certified - Class I (2P+PE), AC125V, 7A or 12A or, 15A etc. Ex.: UL Certified, PSE Certified, BSMI Certified
(2) Flexible cable	Comply with IEC/EN standards or local safety regulation Ex.: IEC 60227-1: General requirements IEC 60227-5: Polyvinyl chloride insulated cables of rated voltages up to and including 450/750 V - Part 5: Flexible cables (cords) EN 50525-1: General requirements EN 50525-2-11: Electric cables - Low voltage energy cables of rated voltages up to and including 450/750 V (Uo/U) - Part 2-11: Cables for general applications - Flexible cables with thermoplastic PVC insulation
(3) Appliance coupler	Comply with IEC/EN standards or local Safety regulation - IEC / EN 60320-1: Appliance couplers for household and similar general purposes - Part 1: General requirements - Standard Sheet C13: AC250V / 10A

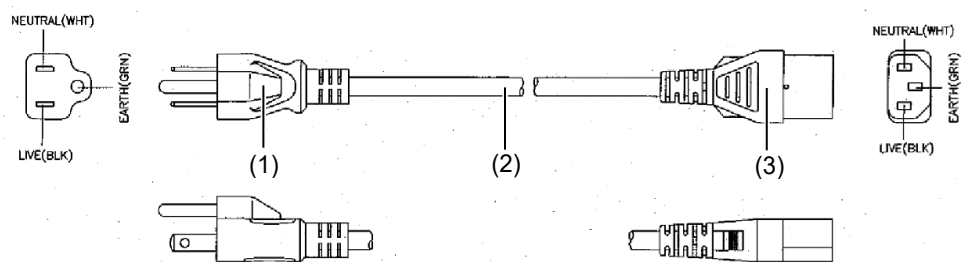

For Japan

Item	Specification
Plug	PSE Certified Class I (2P+PE), AC125V, 7A or higher
Code	PSE Certified 0.75mm ² or larger
Connector	PSE Certified IEC 60320-1 Standard Sheet C13: AC125V/10A or higher

Precautions for use



CAUTION

- If the Manipulator is operated without connecting the brake release unit and the external short connector, the brakes cannot be released and it may cause damage on them. After using the brake release unit, be sure to connect the external short connector to the Manipulator, or check connection of the connector for the brake release unit.
- Keep the external short connector.
Otherwise you cannot release the brakes.
- If you turn ON the brake release unit while the brake release switch is being pressed, an unintended arm may move downward.
Before turning ON the brake release unit, make sure that the brake release switch is not pressed.
- If you turn ON the brake release unit without the connector, it may lead to the short for the male pin used in the connector.
Before turning ON the brake release unit, make sure that the connector is connected.

Mount the brake release unit

- (1) Turn OFF the Controller.
- (2) If the M/C power cable is not connected to the Controller:

Connect the M/C short connector,
or connect the Controller.
(Keep the Controller power OFF)

The M/C short connector can be purchased singly.



If the M/C power cable is already connected to the Controller:

Go to the step (3).



- (3) Remove the external short connector.



If the external short connector is the type which is shown below, remove it with a tool.



External short connector

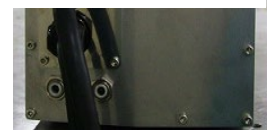

- (4) Connect the brake release unit to the connector of the connection cable.

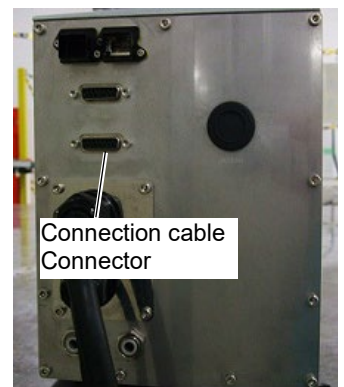

Remove the brake release unit

- (1) Turn OFF the brake release unit.
- (2) Remove the power cable of the brake release unit.
- (3) Disconnect the brake release unit from the connector of the connection cable.
- (4) If the M/C short connector is connected to the M/C power cable, remove the short connector.
- (5) Connect the external short connector to the connector of the connection cable.

NOTE
☞

If the external short connector is the type which is shown below, connect it with a tool.



How to use the brake release unit



- After releasing the brake, the arm may fall by its own weight or move to the unexpected direction. Make sure to prepare a countermeasure to prevent the arm from falling and check the operation environment is safe.
- If the arm you released its brake moves awkwardly or faster than usual, stop the operation promptly and contact the supplier of your region. The brake release unit may be broken.
If you keep operating the Manipulator, it may lead to the breakdown of the Manipulator or you may get your hand or fingers caught.

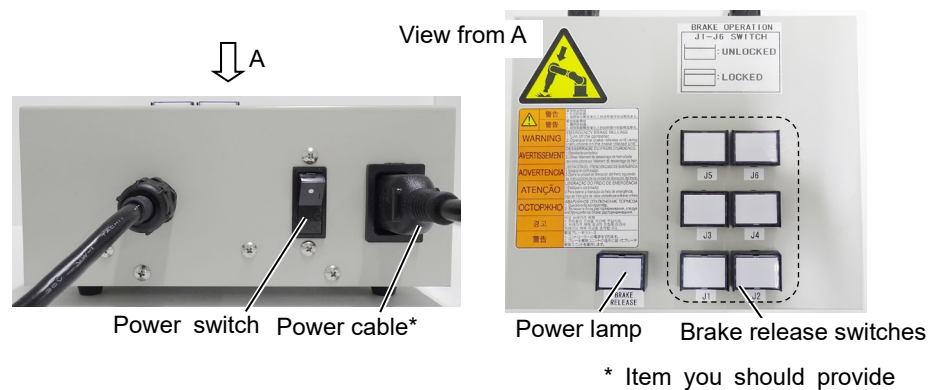

- (1) Refer to “Mount the brake release unit” above to connect the brake release unit to the connector of the connection cable.
- (2) Plug the power cable into the brake release unit.
- (3) Plug the power cable into the power supply plug.
- (4) Turn ON the brake release unit.
When the brake release unit is enabled, the power lamp lights up.
- (5) Press the switch of the arm (J1 to J6) you want to move and then move the arm.
Press the switch again. The brake will be released.
The brake will be enabled by pressing the switch once again.

NOTE Move the arm the brake is released by two persons or more (one presses the switch and one moves the arm). The arm can be very heavy and needs the significant force to move.

6.2 Camera Plate Unit

To mount a camera to the C12 series Manipulator, you need to mount the camera plate unit first.

Appearance of arm end with camera

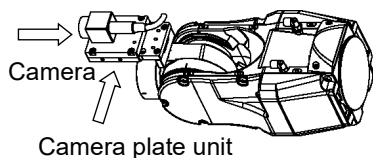

Camera plate unit

Parts included	Qty.
A Camera adapter plate	1
B Camera mid plate	1
C Camera base plate	1
D Hexagon socket head screws M4×12	6
E Hexagon socket head screws M4×20	2
F Plain washer for M4 (small washer)	2

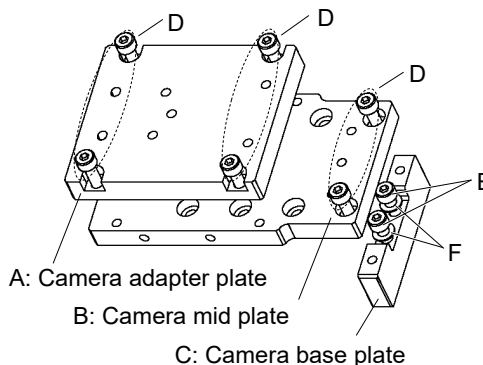

Installation

NOTE For details of tightening the hexagon socket head screws, refer to “*Regular Inspection 3.4 Tightening Hexagon Socket Head Bolts*”

Mounting holes for the camera base plate on the C12 series Manipulator

Camera base plate mounting hole

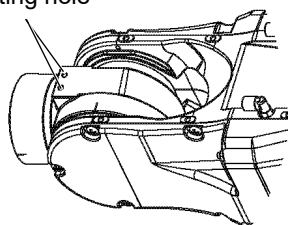

For the installation steps, refer to the following manual:

Epson RC+ Option Vision Guide Hardware & Setup

Dimension of the camera plate unit

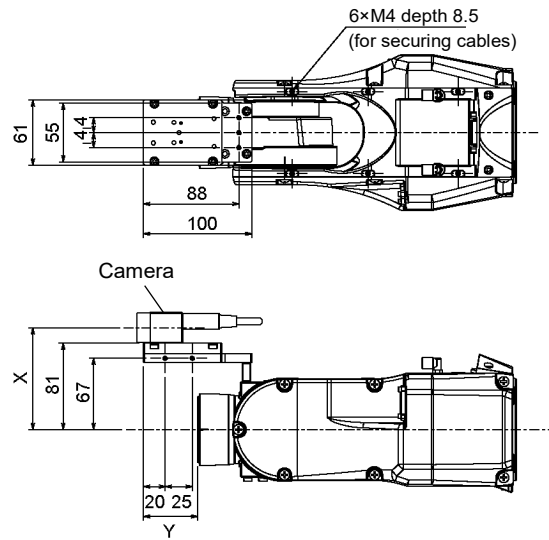

Dimensions X and Y will change depending on the position of camera mid plate and camera size. Refer to the table below for the values.

Camera mid plate

The camera mid plate uses the mounting holes A to D.

By using the different mounting holes, it can be mounted to the camera base plate in the different four positions.

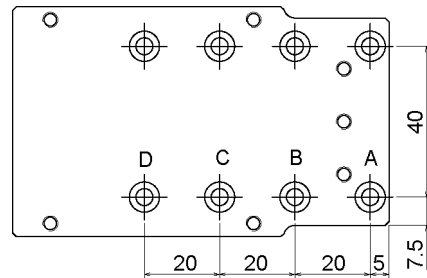

Camera and C12 series Manipulator Joint #5 motion range (reference values)

The Joint #5 motion range varies depending on the mounting position of camera mid plate and the camera you are using.

The table below shows the motion range (reference values) based on the available cameras for this option and the mounting positions of the camera mid plate. The values in the table may vary depending on how to secure the cables.

By changing the Y position, you can extend the distance from the end effector mounting surface to the camera. Also, you can attach the larger end effector. However, be careful about the Joint #5 motion range that will be limited in this case.

	A	B	C	D	X
USB camera, GigE camera	-135 to +70°	-135 to +60°	-135 to +45°	-135 to +35°	95.5 mm

	A	B	C	D
Y	50 mm	30 mm	10 mm	-10 mm

Direction of the Joint #5 motion

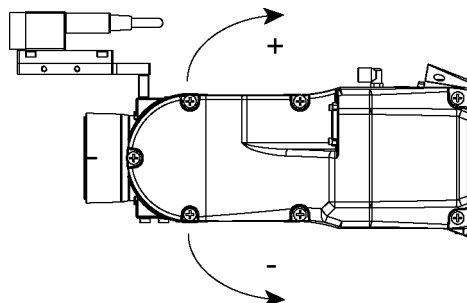

6.3 Tool Adapter (ISO Flange)

Using the tool adapter, you can mount the end effector whose dimensions are designed for the ISO flange to the C12 series Manipulators.

Parts included	Qty.
ISO flange	1
Flange	1
Pin	2
Hexagon socket head screw with low head M5×10	6
Hexagon socket head screw M5×15	4

Dimensions of ISO flange

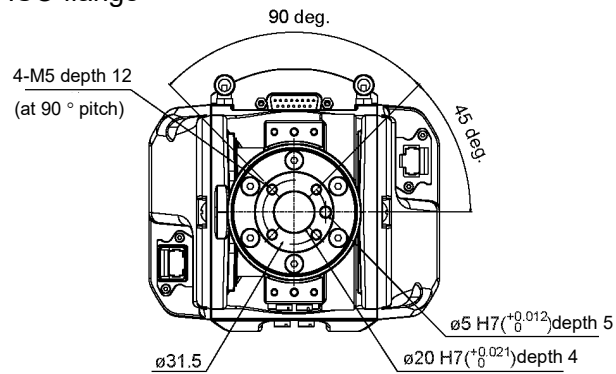

* Each dimension and tolerance complies with ISO9409-1-31.5-4-M5.

To mount the ISO flange

NOTE  For details of tightening the hexagon socket head screws, refer to “Regular Inspection 3.4 Tightening Hexagon Socket Head Bolts”

- (1) Press-fit the pin to the Arm #6 end flange.

Pin projection : 4 mm from the flange

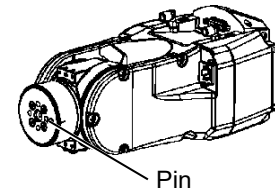

- (2) Align the pin and the pin hole on the flange, and then mount the flange.

Hexagon socket head screw: 4-M5×15

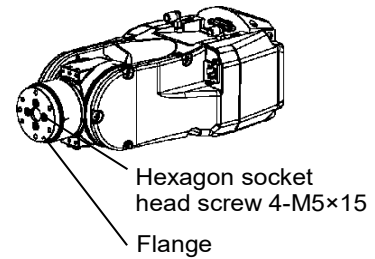

- (3) Press-fit the pin to the installed flange.

Pin protrusion: 4 mm from the flange

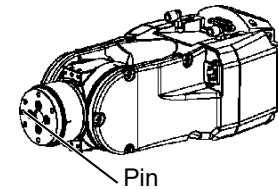

- (4) Align the pin and the pin hole on the ISO flange, and then mount the ISO flange.

Hexagon socket head screw with low head: 6-M5×10

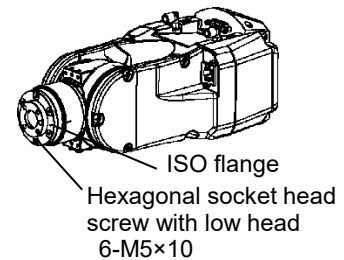

6.4 Adjustable Mechanical Stops

This option is used to mechanically limit the motion range of the Manipulator.

For installation and angle restriction measures, refer to “5.2 Motion Range Setting by Mechanical Stops”.

Adjustable mechanical stop (J1)

Item	Qty.
Adjustable mechanical stop (J1)	1
Hexagon socket head screw M12×30	2

Adjustable mechanical stop (J2)

Item	Qty.
Adjustable mechanical stop (J2)	1
Hexagon socket head screw M10×35	2

Adjustable mechanical stop (J3)

Item	Qty.
Adjustable mechanical stop (J3)	1
Hexagon socket head screw M6×15	2

6.5 User Wires and Pneumatic Tubes

Use the following options when using the internal wiring and tubing for the end effector drive.

They are attached to Manipulators as standard. The parts can be additionally purchased in case of lost or shortage.

Fitting for customer use (ø6 straight)

Item	Qty.	Manufacturer	Standard
ø6 straight fitting	2	SMC	KQ2S06-M6N

Fitting for customer use (ø6 elbow)

Item	Qty.	Manufacturer	Standard
ø6 elbow fitting	2	SMC	KQ2L06-M6N

Standard user connector kit (D-sub)

Item	Qty.	Manufacturer	Standard
Connector	2	JAE	DA-15PF-N (Solder type)
Clamp hood	2	HRS	HDA-CTH(4-40)(10) (Connector setscrew: #4-40 UNC)

Regular Inspection

Performing inspection properly is essential to prevent trouble and ensure safety.
This volume describes the inspection schedule and contents.
Inspect according to the schedule.

1. Regular Inspection for C4 Manipulator

This chapter describes maintenance inspection procedures. Performing maintenance inspection properly is essential to prevent trouble and ensure safety.

Be sure to perform the maintenance inspections in accordance with the schedule.

1.1 Inspection

1.1.1 Schedule for Inspection

Inspection points are divided into five stages: daily, monthly, quarterly, biannual, and annual. The inspection points are added every stage.

If the Manipulator is operated for 250 hours or longer per month, the inspection points must be added every 250 hours, 750 hours, 1500 hours, and 3000 hours operation.

	Inspection Point					
	Daily inspection	Monthly inspection	Quarterly inspection	Biannual inspection	Annual inspection	Overhaul (replacement)
1 month (250 h)	Inspect every day	√				
2 months (500 h)		√				
3 months (750 h)		√	√			
4 months (1000 h)		√				
5 months (1250 h)		√				
6 months (1500 h)		√	√	√		
7 months (1750 h)		√				
8 months (2000 h)		√				
9 months (2250 h)		√	√			
10 months (2500 h)		√				
11 months (2750 h)		√				
12 months (3000 h)		√	√	√	√	
13 months (3250 h)		√				
⋮	⋮	⋮	⋮	⋮	⋮	
20000 h						√

h = hour

1.1.2 Inspection Point

Inspection Item

Inspection Point	Inspection Place	Daily	Monthly	Quarterly	Biannual	Annual
Check looseness or backlash of bolts/screws.	End effector mounting bolts	√	√	√	√	√
	Manipulator mounting bolts	√	√	√	√	√
Check looseness of connectors.	External connectors on Manipulator (on the connector plates etc.)	√	√	√	√	√
Visually check for external defects. Clean up if necessary.	External appearance of Manipulator	√	√	√	√	√
	External cables		√	√	√	√
Check for bends or improper location. Repair or place it properly if necessary.	Safeguard etc.	√	√	√	√	√
Check either the external short connector or the brake release unit connector is connected.	The external short connector on the back side of the Manipulator, or the brake release unit connector.	√	√	√	√	√
Check the brake operation	Brake for arm #1 to #6	√	√	√	√	√
Check whether unusual sound or vibration occurs.	Whole	√	√	√	√	√

Inspection Method

Inspection Point	Inspection Method
Check looseness or backlash of bolts/screws.	Use a hexagonal wrench to check that the end effector mounting bolts and the Manipulator mounting bolts are not loose. When the bolts are loose, refer to "1.4 Tightening Hexagon Socket Head Bolts" and tighten them to the proper torque.
Check looseness of connectors.	Check that connectors are not loose. When the connectors are loose, reattach it not to come off.
Visually check for external defects. Clean up if necessary.	Check the appearance of the Manipulator and clean up if necessary. Check the appearance of the cable, and if it is scratched, check that there is no cable disconnection.
Check for bends or improper location. Repair or place it properly if necessary.	Check that the safeguard, etc. are located properly. If the location is improper, place it properly.
Check either the external short connector or the brake release unit connector is connected.	Check that either the external short connector or the brake release unit connector is connected. When it is not connected, connect it.
Check the brake operation	Check that the arm does not fall when in MOTOR OFF. If the arm falls when in MOTOR OFF and the brake is not released, contact the supplier.
Check whether unusual sound or vibration occurs.	Check that there is no unusual sound or vibration when operating. If there is something wrong, contact the supplier.

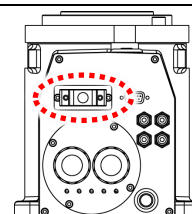

1.2 Overhaul (Parts Replacement)

Overhaul (replacement) shall be performed by personnel who has taken a proper training. For details, refer to “*Safety Manual Training*”.

1.3 Greasing

The reduction gear units and the bevel gear need greasing regularly.

	Greasing part	Greasing Interval	Notice
All Joints	Reduction gear units	Overhaul timing	Greasing shall be performed by personnel who has taken a proper training. For details, “ <i>C series Maintenance Manual</i> ”
Joint # 6	Bevel gear		

1.4 Tightening Hexagon Socket Head Bolts

Hexagon socket head cap bolts (hereinafter, “bolts”) are used in places where mechanical strength is required. These bolts are fastened with the tightening torque shown in the following tables.

When it is required to refasten the bolts in some procedures in this manual (except special cases as noted), use a torque wrench so that the bolts are fastened with appropriate tightening torque as shown below.

Bolt	Tightening Torque
M3	2.0 ± 0.1 N·m (21 ± 1 kgf·cm)
M4	4.0 ± 0.2 N·m (41 ± 2 kgf·cm)
M5	8.0 ± 0.4 N·m (82 ± 4 kgf·cm)
M6	13.0 ± 0.6 N·m (133 ± 6 kgf·cm)
M8	32.0 ± 1.6 N·m (326 ± 16 kgf·cm)
M10	58.0 ± 2.9 N·m (590 ± 30 kgf·cm)
M12	100.0 ± 5.0 N·m (1,020 ± 51 kgf·cm)

See below for the set screw.

Set Screw	Tightening Torque
M4	2.4 ± 0.1 N·m (26 ± 1 kgf·cm)
M5	3.9 ± 0.2 N·m (40 ± 2 kgf·cm)

It is recommended to fasten the bolts aligned on a circumference in a crisscross pattern as shown in the figure below.

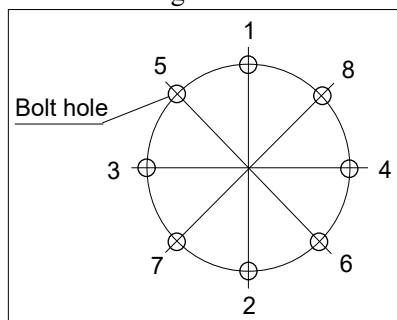

Do not fasten all bolts securely at one time. Divide the number of times to fasten the bolts into two or three and fasten the bolts securely with a hexagonal wrench. Then, use a torque wrench to fasten the bolts with tightening torques shown in the table above.

2. Regular Inspection for C8 Manipulator

This chapter describes maintenance inspection procedures. Performing maintenance inspection properly is essential to prevent trouble and ensure safety.

Be sure to perform the maintenance inspections in accordance with the schedule.

2.1 Inspection

2.1.1 Schedule for Inspection

Inspection points are divided into five stages: daily, monthly, quarterly, biannual, and annual. The inspection points are added every stage.

If the Manipulator is operated for 250 hours or longer per month, the inspection points must be added every 250 hours, 750 hours, 1500 hours, and 3000 hours operation.

	Inspection Point					
	Daily inspection	Monthly inspection	Quarterly inspection	Biannual inspection	Annual inspection	Overhaul (replacement)
1 month (250 h)	Inspect every day	√				
2 months (500 h)		√				
3 months (750 h)		√	√			
4 months (1000 h)		√				
5 months (1250 h)		√				
6 months (1500 h)		√	√	√		
7 months (1750 h)		√				
8 months (2000 h)		√				
9 months (2250 h)		√	√			
10 months (2500 h)		√				
11 months (2750 h)		√				
12 months (3000 h)		√	√	√	√	
13 months (3250 h)		√				
⋮	⋮	⋮	⋮	⋮	⋮	
20000 h						√

2.1.2 Inspection Point

Inspection Item

Inspection Point	Inspection Place	Daily	Monthly	Quarterly	Biannual	Annual
Check looseness or backlash of bolts/screws.	End effector mounting bolts	√	√	√	√	√
	Manipulator mounting bolts	√	√	√	√	√
Check looseness of connectors.	External connectors on Manipulator (on the connector plates etc.)	√	√	√	√	√
Visually check for external defects. Clean up if necessary.	External appearance of Manipulator	√	√	√	√	√
	External cables		√	√	√	√
Check for bends or improper location. Repair or place it properly if necessary.	Safeguard etc.	√	√	√	√	√
Check either the external short connector or the brake release unit connector is connected.	The external short connector on the back side of the Manipulator, or the brake release unit connector.	√	√	√	√	√
Check the brake operation	Brake for arm #1 to #6	√	√	√	√	√
Check whether unusual sound or vibration occurs.	Whole	√	√	√	√	√
Check that fan is working. (only for C8-A1401*** (C8XL))	Fan	√	√	√	√	√

Inspection Method

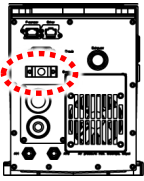
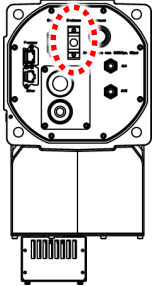
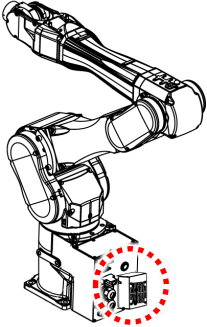
Inspection Point	Inspection Method
Check looseness or backlash of bolts/screws.	Use a hexagonal wrench to check that the end effector mounting bolts and the Manipulator mounting bolts are not loose. When the bolts are loose, refer to “2.4 Tightening Hexagon Socket Head Bolts” and tighten them to the proper torque.
Check looseness of connectors.	Check that connectors are not loose. When the connectors are loose, reattach it not to come off.
Visually check for external defects. Clean up if necessary.	Check the appearance of the Manipulator and clean up if necessary. Check the appearance of the cable, and if it is scratched, check that there is no cable disconnection.
Check for bends or improper location. Repair or place it properly if necessary.	Check that the safeguard, etc. are located properly. If the location is improper, place it properly.
Check either the external short connector or the brake release unit connector is connected.	Check that either the external short connector or the brake release unit connector is connected. When it is not connected, connect it. <div style="display: flex; justify-content: space-around; align-items: center;"> <div style="text-align: center;">  <p>Cable backward</p> </div> <div style="text-align: center;">  <p>Cable downward</p> </div> </div>
Check the brake operation	Check that the arm does not fall when in MOTOR OFF. If the arm falls when in MOTOR OFF and the brake is not released, contact the supplier.
Check whether unusual sound or vibration occurs.	Check that there is no unusual sound or vibration when operating. If there is something wrong, contact the supplier.
Check that fan is working. (only for C8-A1401*** (C8XL))	Check that the fan is working when in MOTOR ON. If the fan is not working when in MOTOR ON, contact the supplier. <div style="text-align: right;">  </div>

2.2 Overhaul (Parts Replacement)

Overhaul (replacement) shall be performed by personnel who has taken a proper training. For details, refer to “*Safety Manual Training*”.

2.3 Greasing

The reduction gear units and the bevel gear need greasing regularly.

	Greasing part	Greasing Interval	Notice
All Joints	Reduction gear units	Overhaul timing	Greasing shall be performed by personnel who has taken a proper training. For details, “ <i>C series Maintenance Manual</i> ”
Joint # 6	Bevel gear		

2.4 Tightening Hexagon Socket Head Bolts

Hexagon socket head cap bolts (hereinafter, “bolts”) are used in places where mechanical strength is required. These bolts are fastened with the tightening torque shown in the following tables.

When it is required to refasten the bolts in some procedures in this manual (except special cases as noted), use a torque wrench so that the bolts are fastened with appropriate tightening torque as shown below.

Bolt	Tightening Torque
M3	2.0 ± 0.1 N·m (21 ± 1 kgf·cm)
M4	4.0 ± 0.2 N·m (41 ± 2 kgf·cm)
M5	8.0 ± 0.4 N·m (82 ± 4 kgf·cm)
M6	13.0 ± 0.6 N·m (133 ± 6 kgf·cm)
M8	32.0 ± 1.6 N·m (326 ± 16 kgf·cm)
M10	58.0 ± 2.9 N·m (590 ± 30 kgf·cm)
M12	100.0 ± 5.0 N·m (1,020 ± 51 kgf·cm)

See below for the set screw.

Set Screw	Tightening Torque
M4	2.4 ± 0.1 N·m (26 ± 1 kgf·cm)
M5	3.9 ± 0.2 N·m (40 ± 2 kgf·cm)
M6	8.0 ± 0.4 N·m (82 ± 4 kgf·cm)

It is recommended to fasten the bolts aligned on a circumference in a crisscross pattern as shown in the figure below.

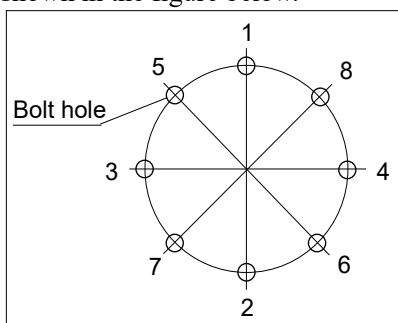

Do not fasten all bolts securely at one time. Divide the number of times to fasten the bolts into two or three and fasten the bolts securely with a hexagonal wrench. Then, use a torque wrench to fasten the bolts with tightening torques shown in the table above.

3. Regular Inspection for C12 Manipulator

This chapter describes maintenance inspection procedures. Performing maintenance inspection properly is essential to prevent trouble and ensure safety.

Be sure to perform the maintenance inspections in accordance with the schedule.

3.1 Inspection

3.1.1 Schedule for Inspection

Inspection points are divided into five stages: daily, monthly, quarterly, biannual, and annual. The inspection points are added every stage.

If the Manipulator is operated for 250 hours or longer per month, the inspection points must be added every 250 hours, 750 hours, 1500 hours, and 3000 hours operation.

	Inspection Point					
	Daily inspection	Monthly inspection	Quarterly inspection	Biannual inspection	Annual inspection	Overhaul (replacement)
1 month (250 h)	Inspect every day	√				
2 months (500 h)		√				
3 months (750 h)		√	√			
4 months (1000 h)		√				
5 months (1250 h)		√				
6 months (1500 h)		√	√	√		
7 months (1750 h)		√				
8 months (2000 h)		√				
9 months (2250 h)		√	√			
10 months (2500 h)		√				
11 months (2750 h)		√				
12 months (3000 h)		√	√	√	√	
13 months (3250 h)		√				
⋮	⋮	⋮	⋮	⋮	⋮	
20000 h						√

3.1.2 Inspection Point

Inspection Item

Inspection Point	Inspection Place	Daily	Monthly	Quarterly	Biannual	Annual
Check looseness or backlash of bolts/screws.	End effector mounting bolts	√	√	√	√	√
	Manipulator mounting bolts	√	√	√	√	√
Check looseness of connectors.	External connectors on Manipulator (on the connector plates etc.)	√	√	√	√	√
Visually check for external defects. Clean up if necessary.	External appearance of Manipulator	√	√	√	√	√
	External cables		√	√	√	√
Check for bends or improper location. Repair or place it properly if necessary.	Safeguard etc.	√	√	√	√	√
Check either the external short connector or the brake release unit connector is connected.	The external short connector on the back side of the Manipulator, or the brake release unit connector.	√	√	√	√	√
Check the brake operation	Brake for arm #1 to #6	√	√	√	√	√
Check whether unusual sound or vibration occurs.	Whole	√	√	√	√	√
Check that fan is working.	Fan	√	√	√	√	√

Inspection Method

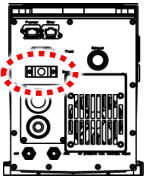
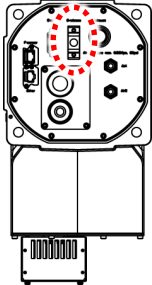
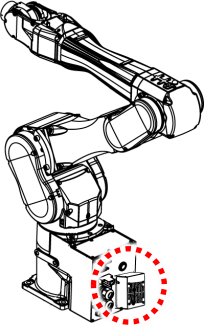
Inspection Point	Inspection Method
Check looseness or backlash of bolts/screws.	Use a hexagonal wrench to check that the end effector mounting bolts and the Manipulator mounting bolts are not loose. When the bolts are loose, refer to “3.4 Tightening Hexagon Socket Head Bolts” and tighten them to the proper torque.
Check looseness of connectors.	Check that connectors are not loose. When the connectors are loose, reattach it not to come off.
Visually check for external defects. Clean up if necessary.	Check the appearance of the Manipulator and clean up if necessary. Check the appearance of the cable, and if it is scratched, check that there is no cable disconnection.
Check for bends or improper location. Repair or place it properly if necessary.	Check that the safeguard, etc. are located properly. If the location is improper, place it properly.
Check either the external short connector or the brake release unit connector is connected.	Check that either the external short connector or the brake release unit connector is connected. When it is not connected, connect it.  Cable backward  Cable downward
Check the brake operation	Check that the arm does not fall when in MOTOR OFF. If the arm falls when in MOTOR OFF and the brake is not released, contact the supplier.
Check whether unusual sound or vibration occurs.	Check that there is no unusual sound or vibration when operating. If there is something wrong, contact the supplier.
Check that fan is working.	Check that the fan is working when in MOTOR ON. If the fan is not working when in MOTOR ON, contact the supplier. 

3.2 Overhaul (Parts Replacement)

Overhaul (replacement) shall be performed by personnel who has taken a proper training. For details, refer to “*Safety Manual Training*”.

3.3 Greasing

The reduction gear units and the bevel gear need greasing regularly.

	Greasing part	Greasing Interval	Notice
All Joints	Reduction gear units	Overhaul timing	Greasing shall be performed by personnel who has taken a proper training. For details, see “ <i>C series Maintenance Manual</i> ”
Joint # 6	Bevel gear		

3.4 Tightening Hexagon Socket Head Bolts

Hexagon socket head cap bolts (hereinafter, “bolts”) are used in places where mechanical strength is required. These bolts are fastened with the tightening torque shown in the following tables.

When it is required to refasten the bolts in some procedures in this manual (except special cases as noted), use a torque wrench so that the bolts are fastened with appropriate tightening torque as shown below.

Bolt	Tightening Torque
M3	2.0 ± 0.1 N·m (21 ± 1 kgf·cm)
M4	4.0 ± 0.2 N·m (41 ± 2 kgf·cm)
M5	8.0 ± 0.4 N·m (82 ± 4 kgf·cm)
M6	13.0 ± 0.6 N·m (133 ± 6 kgf·cm)
M8	32.0 ± 1.6 N·m (326 ± 16 kgf·cm)
M10	58.0 ± 2.9 N·m (590 ± 30 kgf·cm)
M12	100.0 ± 5.0 N·m (1,020 ± 51 kgf·cm)

See below for the set screw.

Set Screw	Tightening Torque
M4	2.4 ± 0.1 N·m (26 ± 1 kgf·cm)
M5	3.9 ± 0.2 N·m (40 ± 2 kgf·cm)
M6	8.0 ± 0.4 N·m (82 ± 4 kgf·cm)

It is recommended to fasten the bolts aligned on a circumference in a crisscross pattern as shown in the figure below.

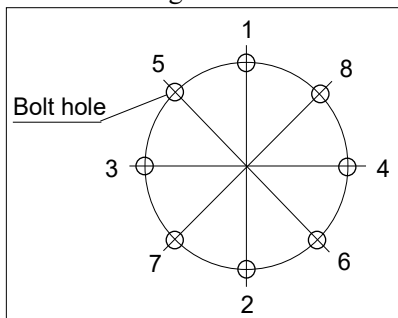

Do not fasten all bolts securely at one time. Divide the number of times to fasten the bolts into two or three and fasten the bolts securely with a hexagonal wrench. Then, use a torque wrench to fasten the bolts with tightening torques shown in the table above.

Appendix

This volume describes the specifications table for each model and detailed data of stopping time and stopping distance.

Appendix A: Specifications

C4 Specifications

Item		Specification	
Model Number		C4-A601**	C4-A901**
Model Name		C4	C4L
Mounting type		Table Top mounting (Ceiling mounting) *1	
Weight (not include the weight of cables or shipping jigs)		27 kg (59.5 lbs.)	30 kg (66.1 lbs.)
Driving method	All joints	AC servo motor	
Max. operating speed *2	Joint #1	450°/s	275°/s
	Joint #2	450°/s	275°/s
	Joint #3	514°/s	289°/s
	Joint #4	555°/s	
	Joint #5	555°/s	
	Joint #6	720°/s	
Maximum synthetic speed		9459 mm/s	8495 mm/s
Repeatability	Joint #1 to #6	± 0.02 mm	± 0.03 mm
Max. motion range	Joint #1	± 170°	±170° (UL specification ± 160°)
		± 180° without the mechanical stop	
	Joint #2	- 160° to + 65°	
	Joint #3	- 51° to + 225°.	
	Joint #4	± 200°	
	Joint #5	±135°	
	Joint #6	±360°	
Max. pulse range	Joint #1	± 4951609	± 8102633 (UL specification ±7626008)
		± 5242880 without the mechanical stop	± 8579259 without the mechanical stop
	Joint #2	- 4660338 to + 1893263	- 7626008 to + 3098066
	Joint #3	- 1299798 to + 5734400	- 2310751 to + 10194489
	Joint #4	± 4723316	
	Joint #5	± 3188238	
	Joint #6	± 6553600	
Resolution	Joint #1	0.0000343°/pulse	0.0000210°/pulse
	Joint #2	0.0000343°/pulse	0.0000210°/pulse
	Joint #3	0.0000392°/pulse	0.0000221°/pulse
	Joint #4	0.0000423°/pulse	
	Joint #5	0.0000423°/pulse	
	Joint #6	0.0000549°/pulse	
Motor rated capacity	Joint #1	400 W	
	Joint #2	400 W	
	Joint #3	150 W	
	Joint #4	50 W	
	Joint #5	50 W	
	Joint #6	50 W	
Payload *3	Rated	1 kg	
	Max.	4 kg 5 kg with arm downward positioning	
Allowable moment	Joint #4	4.41 N·m (0.45 kgf·m)	
	Joint #5	4.41 N·m (0.45 kgf·m)	
	Joint #6	2.94 N·m (0.3 kgf·m)	

Appendix A: Specifications

Item		Specification		
Model Number		C4-A601**	C4-A901**	
Model Name		C4	C4L	
Allowable moment of inertia (GD2/4) *4	Joint #4	0.15 kg·m ²		
	Joint #5	0.15 kg·m ²		
	Joint #6	0.10 kg·m ²		
Installed wire for customer use		9 wires (D-sub)		
Installed pneumatic tube for customer use *5		4 pneumatic tubes, Allowable pressure: 0.59MPa (6 kgf/cm ²) (86 psi)		
Environmental requirements *6	Ambient Temperature	5 to 40° *7		
	Ambient relative humidity	20 to 80 % (no condensation)		
	Vibration	4.9 m/s ² (0.5 G) or less		
Noise level *8		L _{Aeq} = 70.2 dB (A)	L _{Aeq} = 70 dB (A) or lower	
Environment		Standard / Cleanroom model & ESD *9		
Applicable Controller		RC700, RC700-A (UL specification: RC700-A only)		
MC cable	Cable weight (Cable only)	For fixing and signal (common to all lengths)	0.09 kg/m	
		For fixing and power (3 m, 5 m, 10 m)	0.33 kg/m	
		For fixing and power (15 m, 20 m)	0.42 kg/m	
		For fixing and power (UL specifications, common to all lengths)	0.33 kg/m	
		For movable and signal (common to all lengths)	0.14 kg/m	
		For movable and power (common to all lengths)	0.38 kg/m	
	Outer diameter	For fixing and signal (common to all lengths)	ø7.7 mm (typ)	
		For fixing and power (3 m, 5 m, 10 m)	ø14.1 mm (typ)	
		For fixing and power (15 m, 20 m)	ø 16.9 mm (typ)	
		For fixing and power (UL specifications, common to all lengths)	ø14.1 mm (typ)	
		For movable and signal (common to all lengths)	ø10.5 mm (typ)	
		For movable and power (common to all lengths)	ø17.0 mm (typ)	
	Minimum bending radius *10	For fixing and signal (common to all lengths)	47 mm	
		For fixing and power (3 m, 5 m, 10 m)	85 mm	
		For fixing and power (15 m, 20 m)	102 mm	
		For fixing and power (UL specifications, common to all lengths)	85 mm	
		For movable and signal (common to all lengths)	100 mm	
		For movable and power (common to all lengths)	100 mm	

Item		Specification	
Model Number		C4-A601**	C4-A901**
Model Name		C4	C4L
Default values (Max. setting values)	SPEED	5 (100)	
	ACCEL *11	5, 5 (120, 120)	
	SpeedS	50 (2000)	
	AccelS	200 (25000)	200 (15000) *12
	Fine	10000, 10000, 10000, 10000, 10000, 10000 (65535, 65535, 65535, 65535, 65535, 65535)	
	Weight	1 (5)	
Safety standard		CE Marking EMC Directive, Machinery Directive, RoHS Directive UKCA Marking EMC Regulations, Machinery Regulations, RoHS Regulations KC Marking, KCs Marking UL standards UL1740, CAN/CSA-Z434	

*1: Manipulators are set to “Table Top mounting” at shipment. To use the Manipulators as “Ceiling mounting”, you need to change the model settings.

For details on how to change the model settings, refer to “C4 Manipulator 5.5 Changing the Robot”, and “Epson RC+ User’s Guide Robot Configuration”.

*2: In case of PTP control

*3: If the payload exceeds the maximum payload, refer to the section “Restrictions on payload exceeding the maximum payload” in “C4 Manipulator 4.3.1 WEIGHT Setting”.

*4: If the center of gravity is at the center of each arm. If the center of gravity is not at the center of each arm, set the eccentric quantity using INERTIA command.

*5: For details of the installed pneumatic tube for customer use, refer to “C4 Manipulator 3.6 User Wires and Pneumatic Tubes”.

*6: For details of the environmental requirements, refer to “C4 Manipulator 3.1 Environmental Conditions”.

*7: When the product is used in a low temperature environment around the minimum temperature of the product specification, or when the product is suspended for a long time on holidays or at night, a collision detection error may occur due to the large resistance of the drive unit immediately after the start of operation. In such a case, it is recommended to warm up for about 10 minutes.

*8: Conditions of Manipulator at measurement are as follows:

Operating conditions: Under rated load, 6 arms simultaneous motion, maximum speed, maximum acceleration/deceleration, and duty 50%.

Measurement point: 1000 mm apart from the rear of Manipulator

*9: The exhaust system in the Cleanroom-model Manipulator draws air from the base interior and arm cover interior.

A crack or other opening in the base unit can cause loss of negative air pressure in the outer part of the arm, which can cause increased dust emission.

Cleanliness level : Class ISO 3 (ISO14644-1)

Exhaust System : Fitting for $\varnothing 8$ mm pneumatic tube

Refer to “C4 Manipulator 3.6 User Wires and Pneumatic Tubes”.

60 L/min vacuum

Exhaust tube : Polyurethane tube

Outer diameter: $\varnothing 8$ mm (Inner diameter: $\varnothing 5$ to 6 mm)

ESD specification uses resin materials with antistatic treatment. This model controls adhesion of dust due to electrification.

*10: Note the following points when wiring the movable MC cable.

- Install the cable not to apply a load to the connector.

- Bend the cable at the minimum bending radius of the movable part or more. The bending radius (a) and dimensions are shown in the figure below.

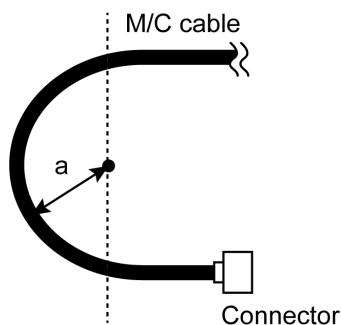

*11: In general use, Accel setting 100 is the optimum setting that maintains the balance of acceleration and vibration when positioning. Although values larger than 100 can be set to Accel, it is recommended to minimize the use of large values to necessary motions since operating the Manipulator continuously with the large Accel setting may shorten the product life remarkably.

*12: Maximum AccelS setting value for payload of 4 kg or more is 12000.

Although setting the value exceeding 12000 does not cause an error, do not set the value in order to prevent Manipulator malfunction.

C8 Specifications

Item		Specification		
Model Number		C8-A701***	C8-A901***	C8-A1401***
Model Name		C8	C8L	C8XL
Mounting type*1		Table Top mounting, Ceiling mounting, Wall mounting		
Weight (not include the weight of cables or shipping jigs)	Standard Cleanroom & ESD	49 kg (108 lbs.)	52 kg (115 lbs.)	62 kg (137 lbs.)
	Protection	53 kg (117 lbs.)	56 kg (123 lbs.)	66 kg (146 lbs.)
Driving method	All joints	AC servo motor		
Max. operating speed *2	Joint #1	331°/s	294°/s	200°/s
	Joint #2	332°/s	300°/s	167°/s
	Joint #3	450°/s	360°/s	200°/s
	Joint #4	480°/s		
	Joint #5	450°/s		
	Joint #6	720°/s		
Maximum synthetic speed		8958 mm/s	9679 mm/s	8858 mm/s
Repeatability	Joints #1 to #6	± 0.02 mm	± 0.03 mm	± 0.05 mm
Max. motion range	Joint #1	± 240°		
	Joint #2	- 158° to + 65°	- 158° to + 65°	- 135° to + 55°
	Joint #3	- 61° to + 202°		
	Joint #4	± 200°		
	Joint #5	± 135°		
	Joint #6	± 360°		
Max. pulse range	Joint #1	± 9507090	± 10695600	± 15736800
	Joint #2	-6245685 to +2569428	- 6903178 to +2839915	- 10616940 to +4325420
	Joint #3	-1776754 to +5883677	- 2220949 to +7354618	- 3997696 to +13238272
	Joint #4	± 5461400		
	Joint #5	± 3932280		
	Joint #6	± 6553800		
Resolution	Joint #1	0.0000252°/pulse	0.0000224°/pulse	0.0000153°/pulse
	Joint #2	0.0000253°/pulse	0.0000229°/pulse	0.0000127°/pulse
	Joint #3	0.0000343°/pulse	0.0000275°/pulse	0.0000153°/pulse
	Joint #4	0.0000366°/pulse		
	Joint #5	0.0000343°/pulse		
	Joint #6	0.0000549°/pulse		
Motor rated capacity	Joint #1	1000 W		
	Joint #2	750 W		
	Joint #3	400 W		
	Joint #4	100 W		
	Joint #5	100 W		
	Joint #6	100 W		
Payload *3	Rated	3 kg		
	Max.	8 kg		
Allowable moment	Joint #4	16.6 N·m (1.69 kgf·m)		
	Joint #5	16.6 N·m (1.69 kgf·m)		
	Joint #6	9.4 N·m (0.96 kgf·m)		
Allowable moment of inertia (GD ² /4) *4	Joint #4	0.47 kg·m ²		
	Joint #5	0.47 kg·m ²		
	Joint #6	0.15 kg·m ²		

Appendix A: Specifications

Item		Specification		
Model Number		C8-A701***	C8-A901***	C8-A1401***
Model Name		C8	C8L	C8XL
Installed wire for customer use		15 wires (D-sub) 8 pin (RJ45) Cat 5e or equivalent 6 pin (for Force Sensor)		
Installed pneumatic tube for customer use *5		ø6 mm pneumatic tubes (2 tubes), Allowable pressure: 0.59 MPa (6 kgf/cm ²) (86 psi)		
Environmental requirements *6	Ambient Temperature	5 to 40°C *7		
	Ambient relative humidity	10 to 80 % (no condensation)		
	Vibration	4.9 m/s ² (0.5 G) or less		
Noise level *8		LAeq = 71.9 dB (A)	LAeq = 70 dB (A) or lower	
Environment		Standard Cleanroom model & ESD *9 Protection model (IP67) *10		
Applicable Controller		RC700-A, RC700DU-A		
MC cable	Cable weight (Cable only)	For fixing and signal (common to all lengths)	0.09 kg/m	
		For fixing and power (3 m, 5 m, 10 m)	0.38 kg/m	
		For fixing and power (15 m, 20 m)	0.43 kg/m	
		For movable and signal (common to all lengths)	0.19 kg/m	
		For movable and power (common to all lengths)	0.46 kg/m	
	Outer diameter	For fixing and signal (common to all lengths)	ø7.7 mm (typ)	
		For fixing and power (3 m, 5 m, 10 m)	ø15.4 mm (typ)	
		For fixing and power (15 m, 20 m)	ø17.4 mm (typ)	
		For movable and signal (common to all lengths)	ø12.1 mm (typ)	
		For movable and power (common to all lengths)	ø19.3 mm (typ)	
	Minimum bending radius *11	For fixing and signal (common to all lengths)	47 mm	
		For fixing and power (3 m, 5 m, 10 m)	93 mm	
		For fixing and power (15 m, 20 m)	105 mm	
		For movable and signal (common to all lengths)	100 mm	
		For movable and power (common to all lengths)	100 mm	
Default values (Max. setting values)	Speed	3 (100)		
	Accel *12	5, 5 (120, 120)		
	SpeedS	50 (2000)		
	AccelS *13	200 (35000)	120 (25000)	
	Fine	10000, 10000, 10000, 10000, 10000, 10000 (131070, 131070, 131070, 131070, 131070, 131070)		
	Weight	3 (8)		
	Inertia	0.03 (0.15)		

Item	Specification		
Model Number	C8-A701***	C8-A901***	C8-A1401***
Model Name	C8	C8L	C8XL
Safety standard	CE Marking EMC Directive, Machinery Directive, RoHS Directive UKCA Marking EMC Regulations, Machinery Regulations, RoHS Regulations KC Marking, KCs Marking UL standards UL1740, CAN/CSA-Z434		

*1: Mounting types other than “Table Top mounting”, “Ceiling mounting”, and “Wall mounting” are out of specification.

*2: In case of PTP control

*3: Do not apply the load exceeding the maximum payload.

*4: If the center of gravity is at the center of each arm. If the center of gravity is not at the center of each arm, set the eccentric quantity using INERTIA command.

*5: For details of the installed pneumatic tube for customer use, refer to “C8 Manipulator 3.6 *User Wires and Pneumatic Tubes*”.

*6: For details of the environmental requirements, refer to “C8 Manipulator 3.1 *Environmental Conditions*”.

*7: When the product is used in a low temperature environment around the minimum temperature of the product specification, or when the product is suspended for a long time on holidays or at night, a collision detection error may occur due to the large resistance of the drive unit immediately after the start of operation. In such a case, it is recommended to warm up for about 10 minutes.

*8: Conditions of Manipulator at measurement are as follows:

Operating conditions: Under rated load, 6 arms simultaneous motion, maximum speed, maximum acceleration/deceleration, and duty 50% for C8/ C8L, 30% for C8XL.

Measurement point: 1000 mm apart from the rear of Manipulator

*9: The exhaust system in the Cleanroom-model Manipulator draws air from the base interior and arm cover interior.

A crack or other opening in the base unit can cause loss of negative air pressure in the outer part of the arm, which can cause increased dust emission.

Cleanliness level : C8, C8L ISO Class 3 (ISO14644-1)
 : C8XL ISO Class 4 (ISO14644-1)

Exhaust system : Fitting for ø12 mm pneumatic tube
 (Reference: *C8 Manipulator 3.6 User Wires and Pneumatic Tubes*)
 60 L/min vacuum

Exhaust tube : Polyurethane tube Outer diameter: ø8 mm (Inner diameter: ø5 to 6 mm)

ESD specification uses resin materials with antistatic treatment. This model controls adhesion of dust due to electrification.

*10 Protection level for the protection-model Manipulators is IP67 (IEC standard). The Manipulators can be used in environments where the possibility of dust, water, and water-soluble cutting oil falling of the Manipulator exists.

However, please be careful of the following:

- The Manipulator is not rust-proofed. Do not use the Manipulator in environment where corrosive liquids exist.
- Fluids that deteriorate the sealing materials, such as organic solvents, acids, alkalis, and chlorine cutting fluids, cannot be used
- The Manipulator cannot be used for underwater operations.
- The Controller does not have protection features against the environment (Controller's protection level: IP20)

Make sure to install the system where environmental requirements for the Controller are satisfied.

<Reference>

- IP40 of IEC standard

[Protection level against ingress of solid objects]

Protection from entry by solid objects with a diameter or thickness greater than 1.0 mm.

[Protection level against ingress of liquids]

No protection

- IP67 of IEC standard

[Protection level against ingress of solid objects]

Totally protected against dust.

[Protection level against liquids]

Protection from ingress of water in harmful quantity when the Manipulator is immersed in water for 30 minutes under the condition that the highest point of the Manipulator is located 0.15 m below the surface of the water and the lowest point is located 1 m below the surface of the water. (Tested while the Manipulator is stopped.)

*11: Note the following points when wiring the movable MC cable.

- Install the cable not to apply a load to the connector.
- Bend the cable at the minimum bending radius of the movable part or more. The bending radius (a) and dimensions are shown in the figure below.

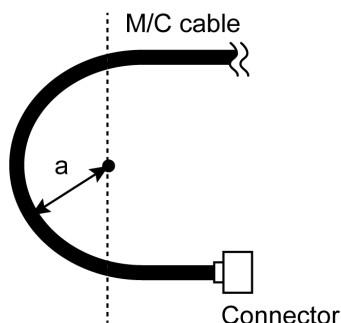

*12: In general use, Accel setting 100 is the optimum setting that maintains the balance of acceleration and vibration when positioning. Although values larger than 100 can be set to Accel, it is recommended to minimize the use of large values to necessary motions since operating the Manipulator continuously with the large Accel setting may shorten the product life remarkably.

*13: Maximum AccelS setting value varies depending on the load. Refer to the table below for details. Setting the value which exceeds the maximum AccelS causes an error. In such a case, check the setting value.

Maximum AccelS setting value

Table Top mounting, Ceiling mounting

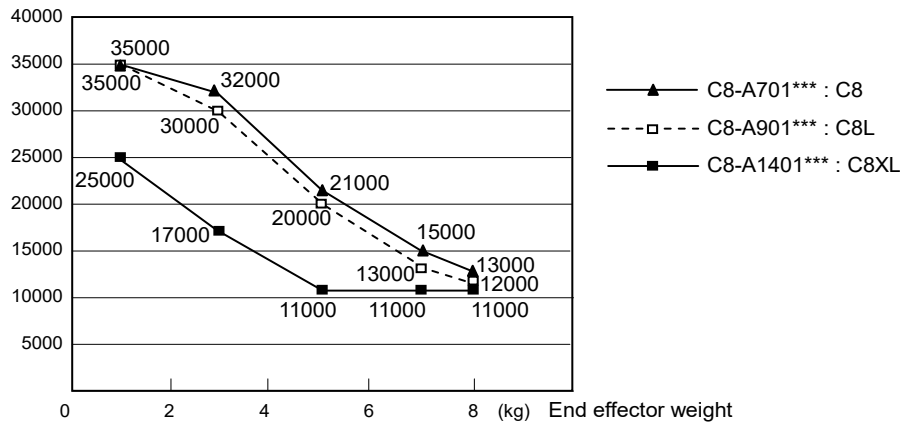

Wall mounting

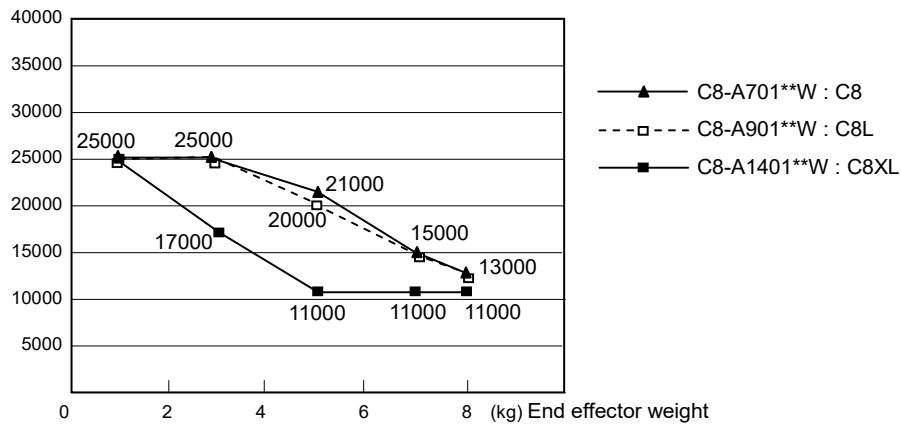

C12 Specifications

Item		Specification
Model Number		C12-A1401**
Model Name		C12XL
Mounting type*1		Table Top mounting
Weight (not include the weight of cables or shipping jigs)	Standard, Cleanroom & ESD	63 kg (139 lbs.)
Driving method	All joints	AC servo motor
Max. operating speed *2	Joint #1	200°/s
	Joint #2	167°/s
	Joint #3	200°/s
	Joint #4	300°/s
	Joint #5	360°/s
	Joint #6	720°/s
Maximum synthetic speed		8751 mm/s
Repeatability	Joints #1 to #6	± 0.05 mm
Max. motion range	Joint #1	± 240°
	Joint #2	- 135 to + 55°
	Joint #3	- 61 to + 202°
	Joint #4	±200°
	Joint #5	± 135°
	Joint #6	± 360°
Max. pulse range	Joint #1	± 15736800
	Joint #2	- 10616940 to +4325420
	Joint #3	- 3997696 to +13238272
	Joint #4	± 8738240
	Joint #5	± 4915350
	Joint #6	± 6553800
Resolution	Joint #1	0.0000153°/pulse
	Joint #2	0.0000127°/pulse
	Joint #3	0.0000153°/pulse
	Joint #4	0.0000229°/pulse
	Joint #5	0.0000275°/pulse
	Joint #6	0.0000549°/pulse
Motor rated capacity	Joint #1	1000 W
	Joint #2	750 W
	Joint #3	400 W
	Joint #4	150 W
	Joint #5	150 W
	Joint #6	150 W
Payload *3	Rated	3 kg
	Max.	12 kg
Allowable moment	Joint #4	25.0 N·m (2.55 kgf·m)
	Joint #5	25.0 N·m (2.55 kgf·m)
	Joint #6	9.8 N·m (1.0 kgf·m)
Allowable moment of inertia (GD2/4) *4	Joint #4	0.70 kg·m ²
	Joint #5	0.70 kg·m ²
	Joint #6	0.20 kg·m ²
Installed wire for customer use		15 wires (D-sub) 8 pin (RJ45) Cat 5e or equivalent 6 pin (for Force Sensor)

Item		Specification	
Model Number		C12-A1401**	
Model Name		C12XL	
Installed pneumatic tube for customer use *5		ø6 mm pneumatic tubes (2 tubes), Allowable pressure: 0.59 MPa (6 kgf/cm ²) (86 psi)	
Environmental requirements *6	Ambient Temperature	5 to 40 °C *7	
	Ambient relative humidity	10 to 80 % (no condensation)	
	Vibration	4.9 m/s ² (0.5 G) or less	
Noise level *8		LAeq = 70 dB (A) or lower	
Environment		Standard / Cleanroom model & ESD *9	
Applicable Controller		RC700-A	
MC cable	Cable weight (Cable only)	For fixing and signal (common to all lengths)	0.09 kg/m
		For fixing and power (3 m, 5 m, 10 m)	0.38 kg/m
		For fixing and power (15 m, 20 m)	0.43 kg/m
		For movable and signal (common to all lengths)	0.19 kg/m
		For movable and power (common to all lengths)	0.46 kg/m
	Outer diameter	For fixing and signal (common to all lengths)	ø7.7 mm (typ)
		For fixing and power (3 m, 5 m, 10 m)	ø15.4 mm (typ)
		For fixing and power (15 m, 20 m)	ø17.4 mm (typ)
		For movable and signal (common to all lengths)	ø12.1 mm (typ)
		For movable and power (common to all lengths)	ø19.3 mm (typ)
	Minimum bending radius *10	For fixing and signal (common to all lengths)	47 mm
		For fixing and power (3 m, 5 m, 10 m)	93 mm
		For fixing and power (15 m, 20 m)	105 mm
		For movable and signal (common to all lengths)	116 mm
		For movable and power (common to all lengths)	116 mm
Default values (Max. setting values)	Speed	3 (100)	
	Accel *11	5, 5 (120, 120)	
	SpeedS	50 (2000)	
	AccelS *12	120 (25000)	
	Fine	10000, 10000, 10000, 10000, 10000, 10000 (131070, 131070, 131070, 131070, 131070, 131070)	
	Weight	3 (12)	
	Inertia	0.03 (0.2)	

- *1: Mounting types other than “Table Top mounting” is out of specification.
- *2: In case of PTP control
- *3: Do not apply the load exceeding the maximum payload.
- *4: If the center of gravity is at the center of each arm. If the center of gravity is not at the center of each arm, set the eccentric quantity using INERTIA command.
- *5: For details of the installed pneumatic tube for customer use, refer to “C12 Manipulator 3.6 User Wires and Pneumatic Tubes”.
- *6: For details of the environmental requirements, refer to “C12 Manipulator 3.1 Environmental Conditions”.
- *7: When the product is used in a low temperature environment around the minimum temperature of the product specification, or when the product is suspended for a long time on holidays or at night, a collision detection error may occur due to the large resistance of the drive unit immediately after the start of operation. In such a case, it is recommended to warm up for about 10 minutes.

*8: Conditions of Manipulator at measurement are as follows:

Operating conditions: Under rated load, 6 arms simultaneous motion, maximum speed, maximum acceleration/deceleration, and duty of robot operation time 30%.

Measurement point: 1000 mm apart from the rear of Manipulator

*9: The exhaust system in the Cleanroom-model Manipulator draws air from the base interior and arm cover interior.

A crack or other opening in the base unit can cause loss of negative air pressure in the outer part of the arm, which can cause increased dust emission.

Cleanliness level : ISO Class 4 (ISO14644-1)

Exhaust system : Fitting for $\phi 12$ mm pneumatic tube
(Reference:C12 Manipulator 3.6 User Wires and Pneumatic Tubes)
60 L/min vacuum

Exhaust tube : Polyurethane tube Outer diameter: $\phi 8$ mm (Inner diameter: $\phi 5$ to 6 mm)

ESD specification uses resin materials with antistatic treatment. This model controls adhesion of dust due to electrification.

*10: Note the following points when wiring the movable MC cable.

- Install the cable not to apply a load to the connector.
- Bend the cable at the minimum bending radius of the movable part or more. The bending radius (a) and dimensions are shown in the figure below.

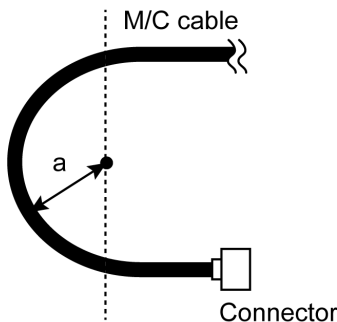

*11: In general use, Accel setting 100 is the optimum setting that maintains the balance of acceleration and vibration when positioning. Although values larger than 100 can be set to Accel, it is recommended to minimize the use of large values to necessary motions since operating the Manipulator continuously with the large Accel setting may shorten the product life remarkably.

*12: Maximum AccelS setting value varies depending on the load. Refer to the table below for details. Setting the value which exceeds the maximum AccelS causes an error. In such a case, check the setting value.

Maximum AccelS setting value

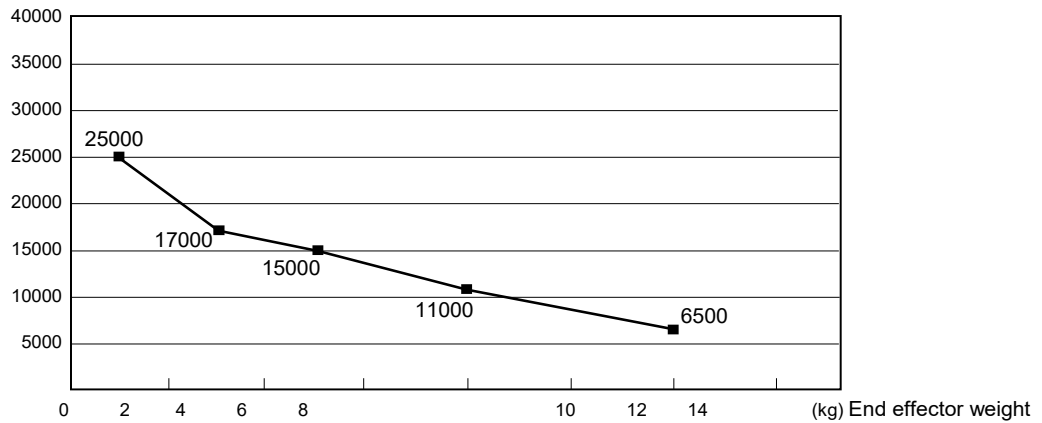

Appendix B: Stopping time and Stopping distance in Emergency

The stopping time and stopping distance in emergency stop are shown in a graph for each model.

The stopping time is “Stopping time” in the figure below. Be sure to confirm that safety is ensured according to the installation environment and operation of the robot.

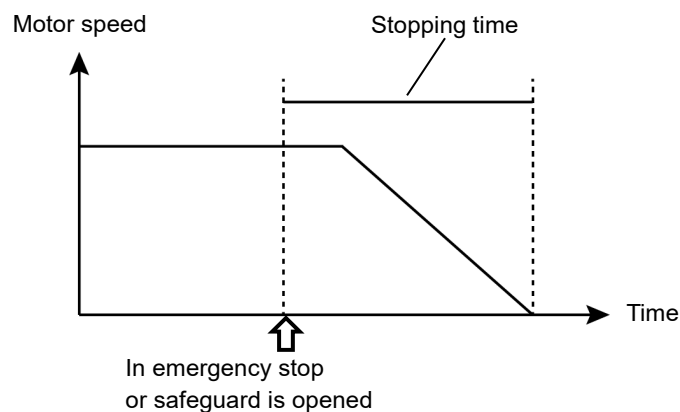

Condition :

The stopping time and stopping distance vary depending on the parameters (setting value) set for the robot. In this chapter, the time and distance are shown with the following parameters.

Accel : 100 ,100

Other : Default

Description of legend:

The graph is shown for each Weight value (rated value, 100%, about 66%, and about 33% of the maximum payload).

Horizontal axis : Arm speed (Speed value)

Vertical axis : Stopping time and stopping distance in each arm speed

Time [sec] : Stopping time

Distance [deg] : Stopping distance

C4 Stopping time and Stopping distance in Emergency

C4-A601**: J1 (Table Top mounting, Ceiling mounting)

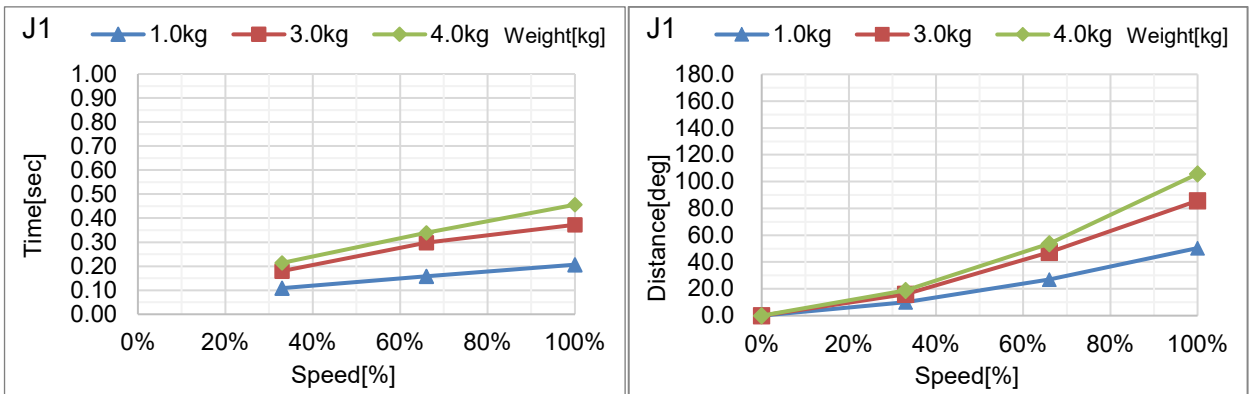

C4-A601**: J2 (Table Top mounting, Ceiling mounting)

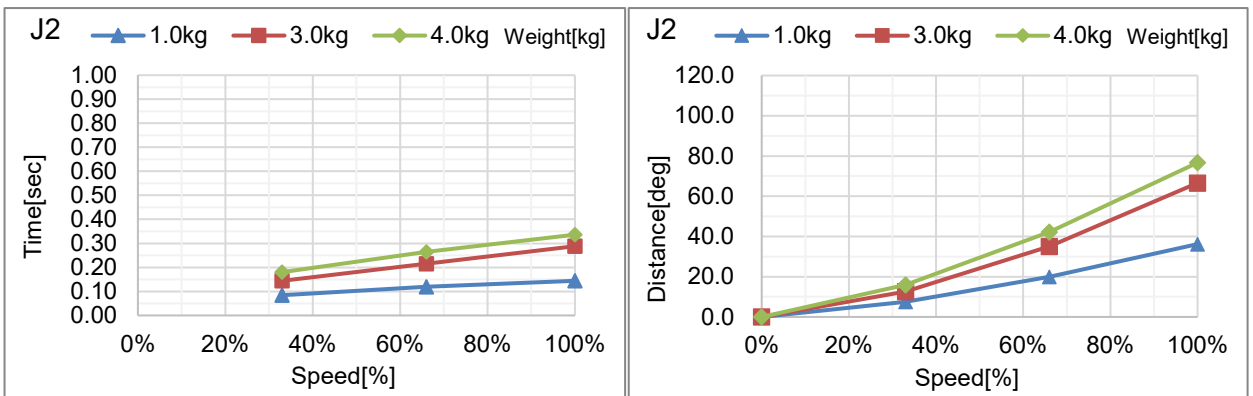

C4-A601**: J3 (Table Top mounting, Ceiling mounting)

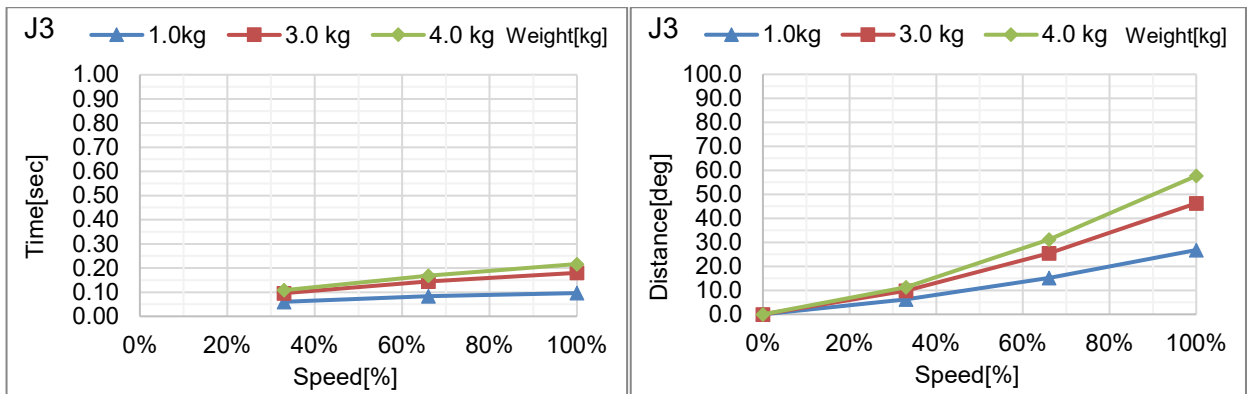

C4-A601**: J4 (Table Top mounting, Ceiling mounting)

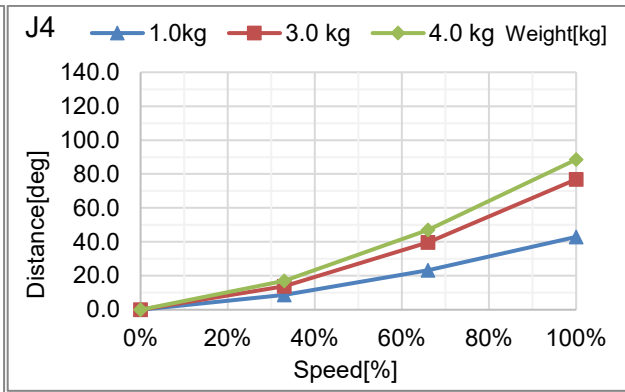
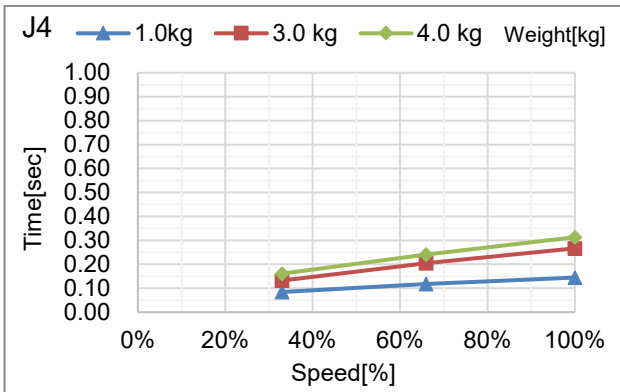

C4-A601**: J5 (Table Top mounting, Ceiling mounting)

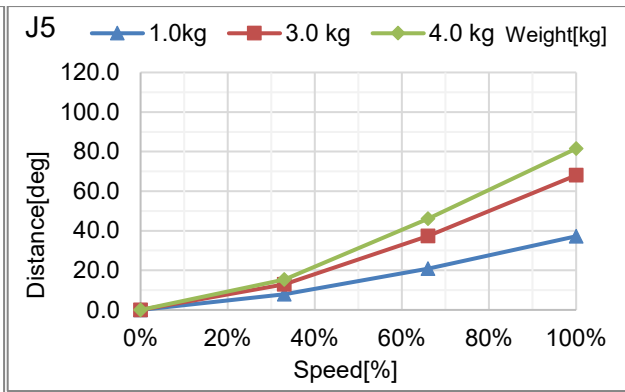
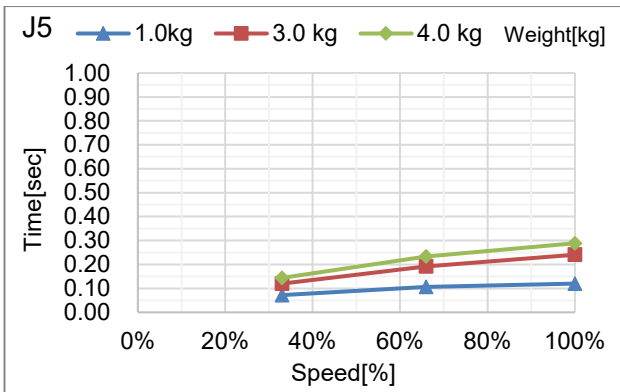

C4-A601**: J6 (Table Top mounting, Ceiling mounting)

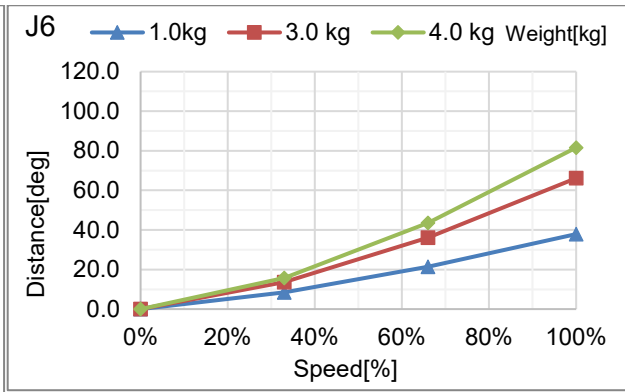
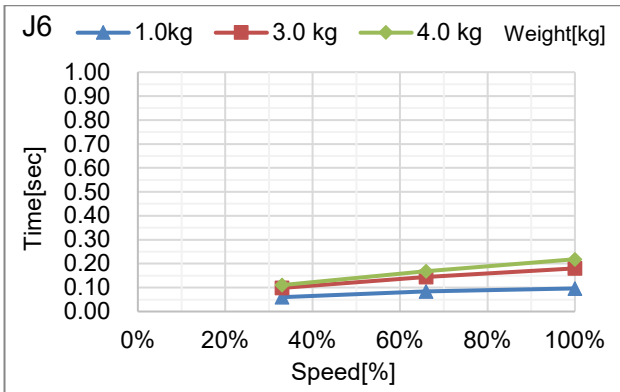

C4-A901**: J1 (Table Top mounting, Ceiling mounting)

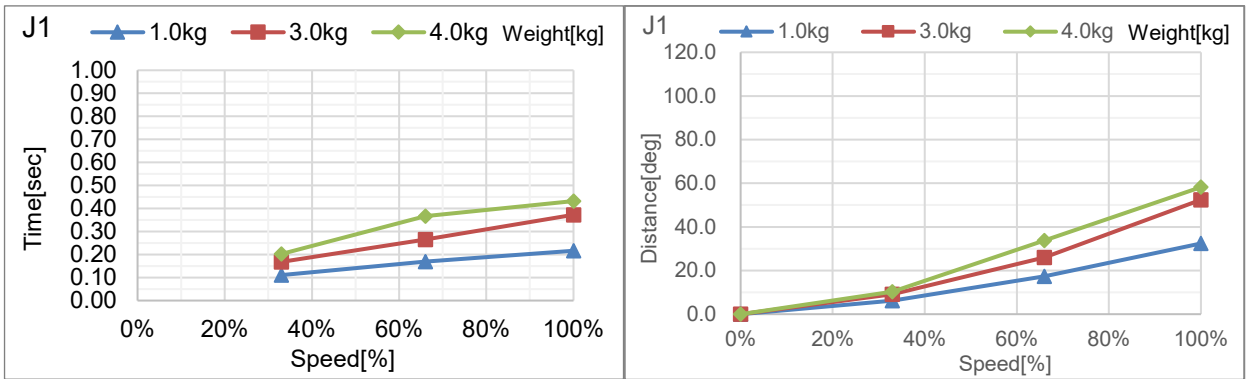

C4-A901**: J2 (Table Top mounting, Ceiling mounting)

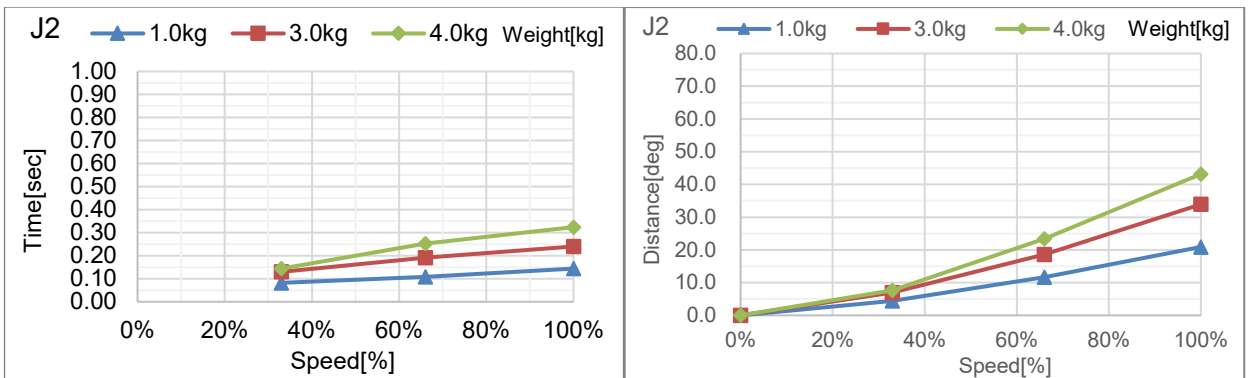

C4-A901**: J3 (Table Top mounting, Ceiling mounting)

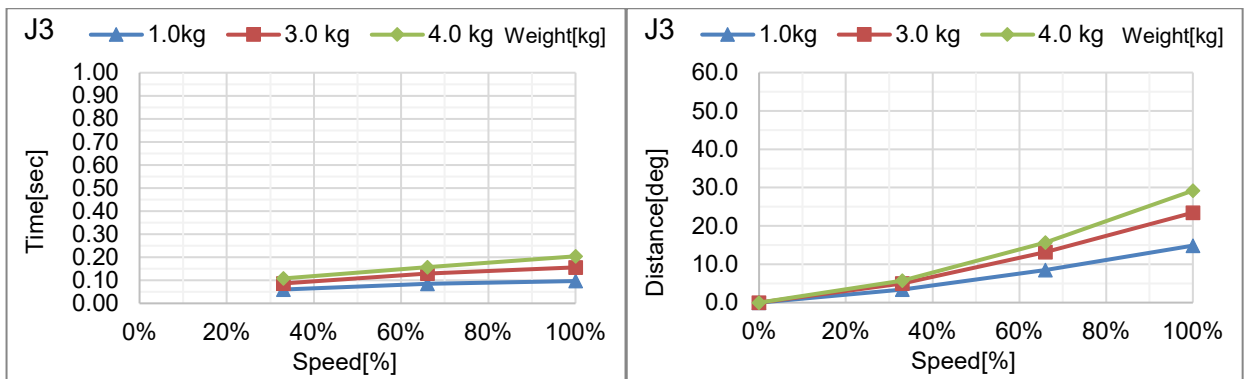

C4-A901**: J4 (Table Top mounting, Ceiling mounting)

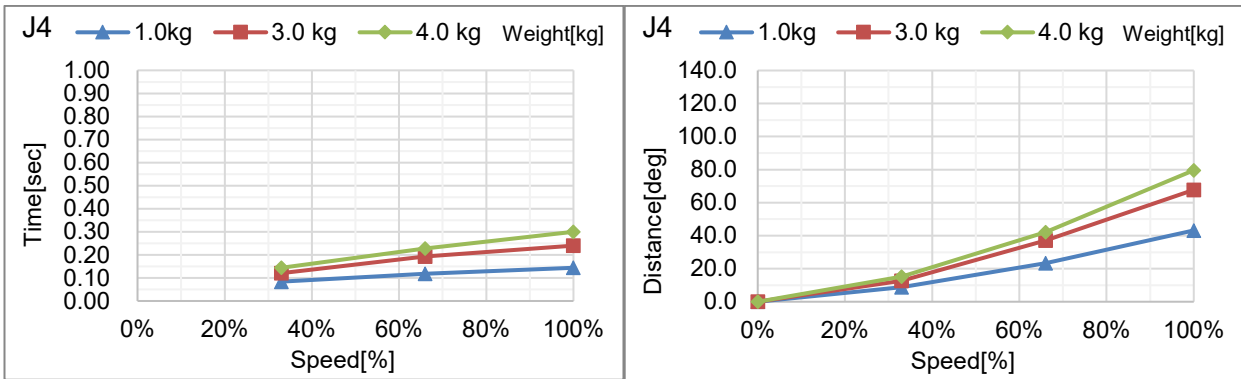

C4-A901**: J5 (Table Top mounting, Ceiling mounting)

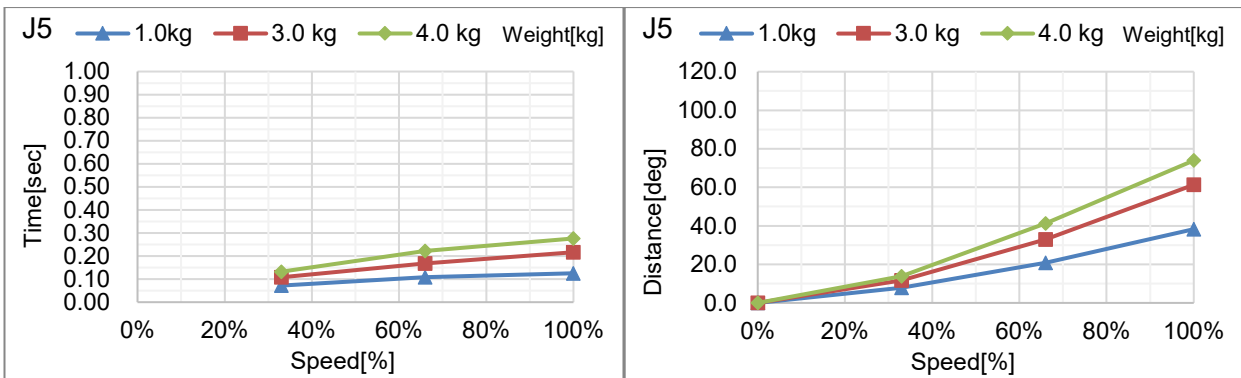

C4-A901**: J6 (Table Top mounting, Ceiling mounting)

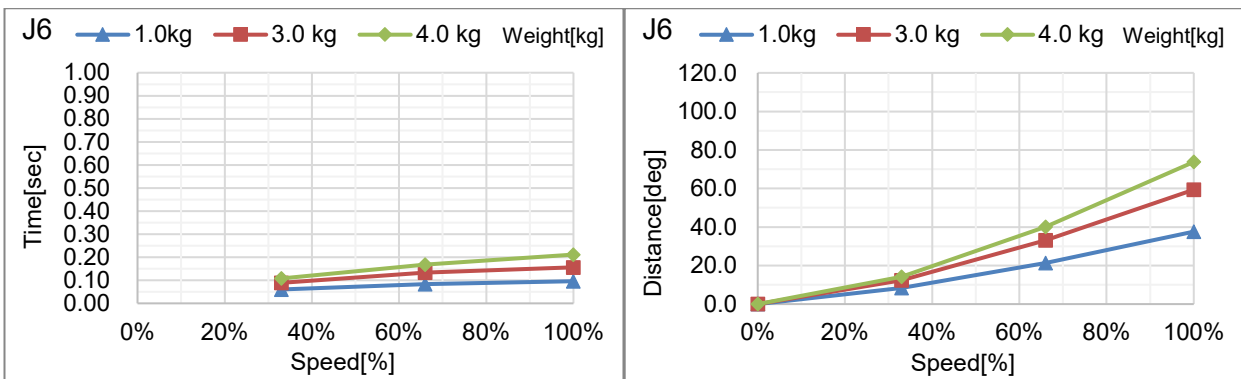

C8 Stopping time and Stopping distance in Emergency

C8-A701***: J1 (Table Top mounting, Ceiling mounting)

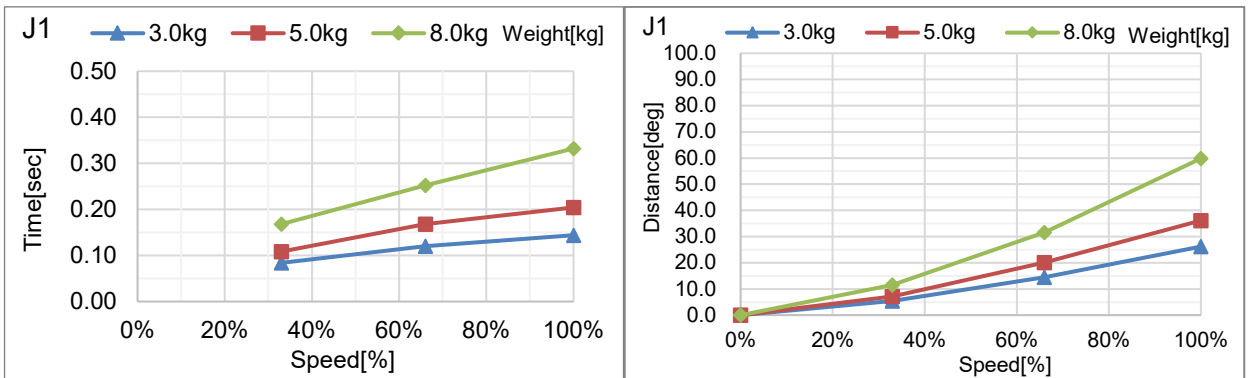

C8-A701***: J2 (Table Top mounting, Ceiling mounting)

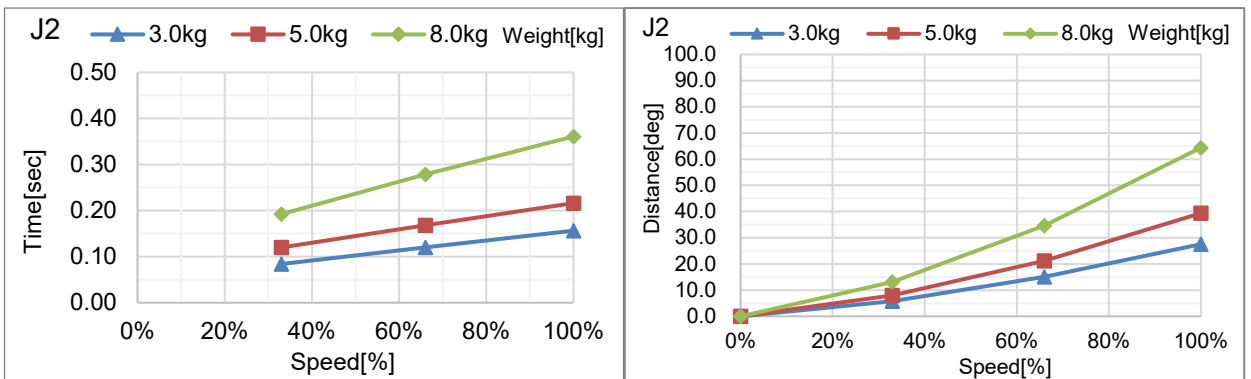

C8-A701***: J3 (Table Top mounting, Ceiling mounting)

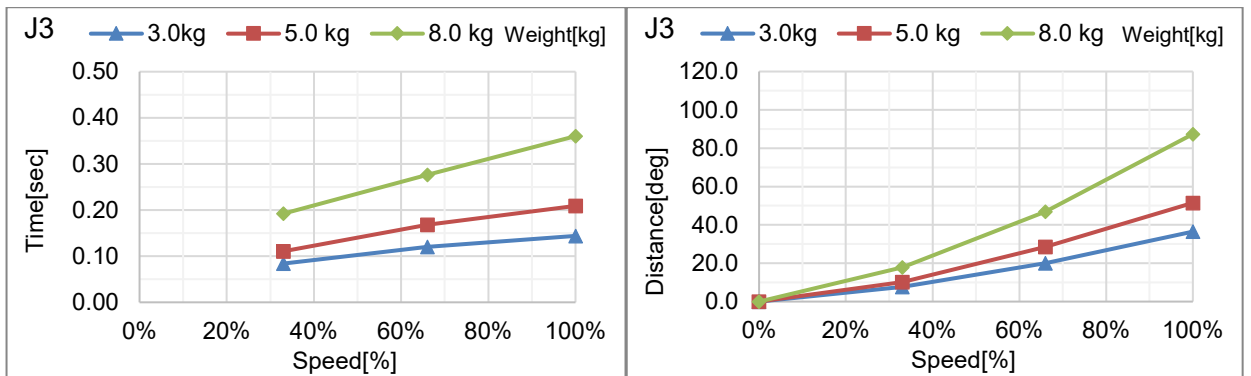

C8-A701***: J4 (Table Top mounting, Ceiling mounting)

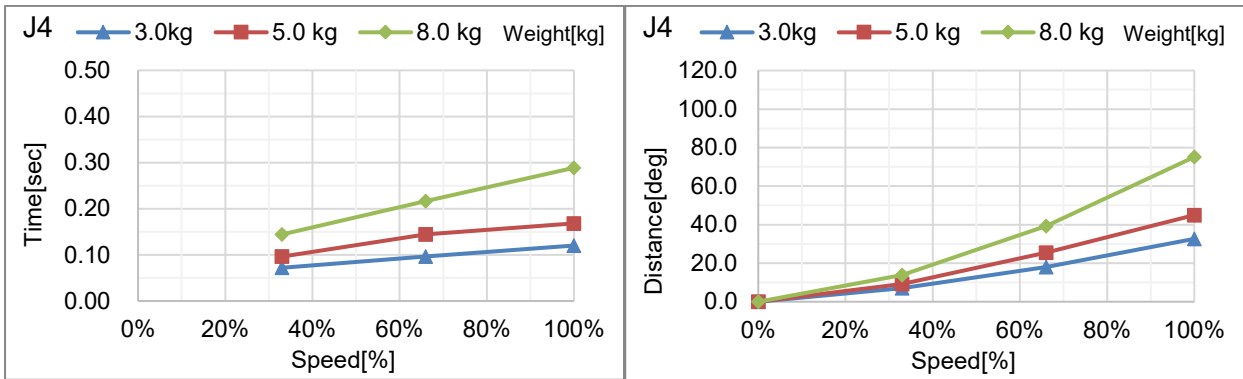

C8-A701***: J5 (Table Top mounting, Ceiling mounting)

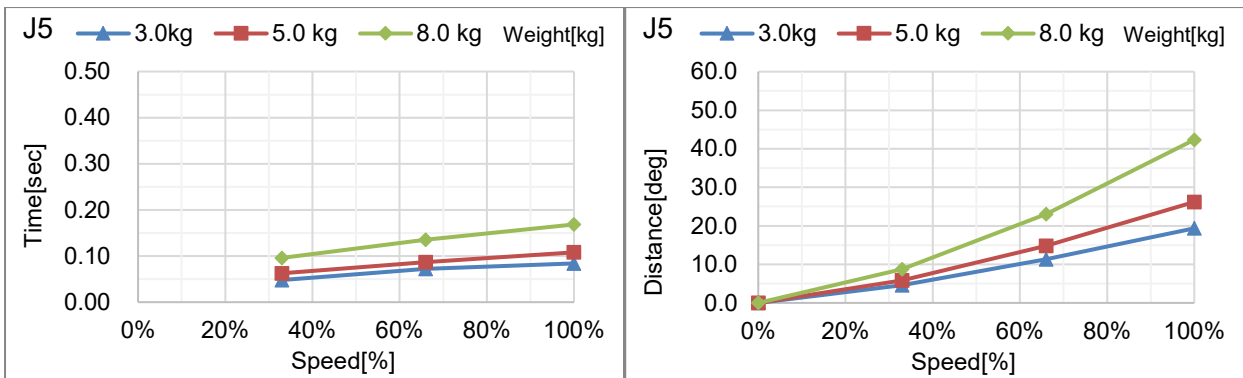

C8-A701***: J6 (Table Top mounting, Ceiling mounting)

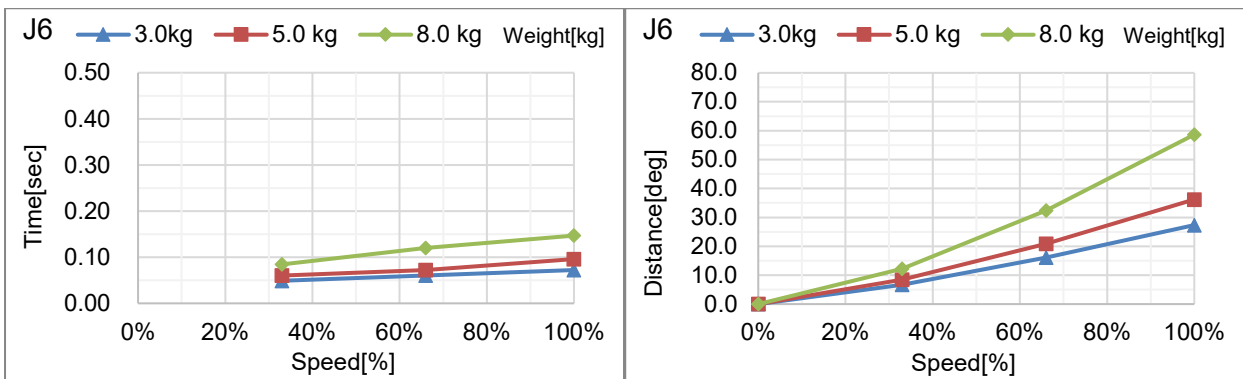

C8-A701***: J1 (Wall mounting)

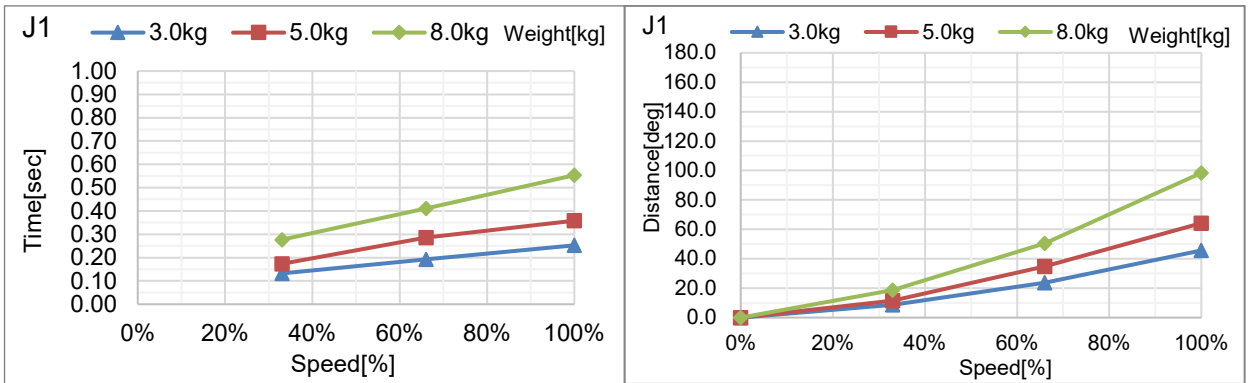

C8-A701***: J2 (Wall mounting)

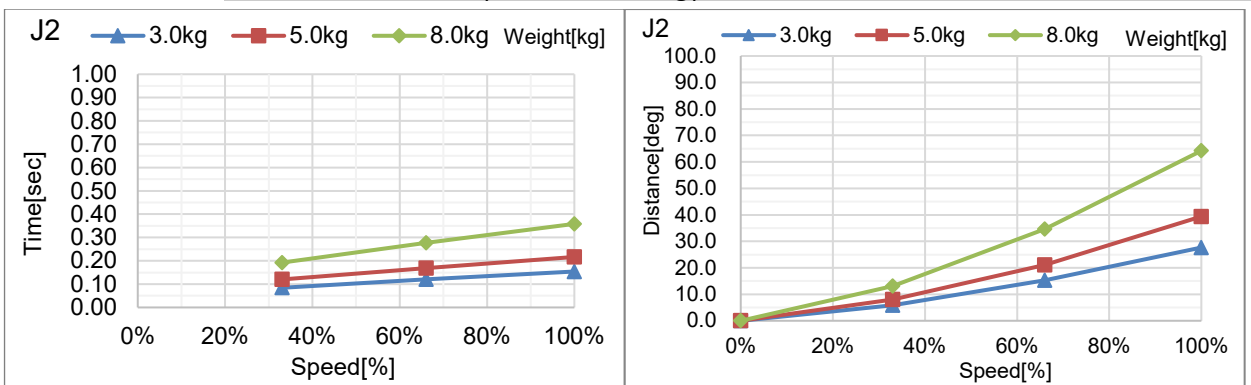

C8-A701***: J3 (Wall mounting)

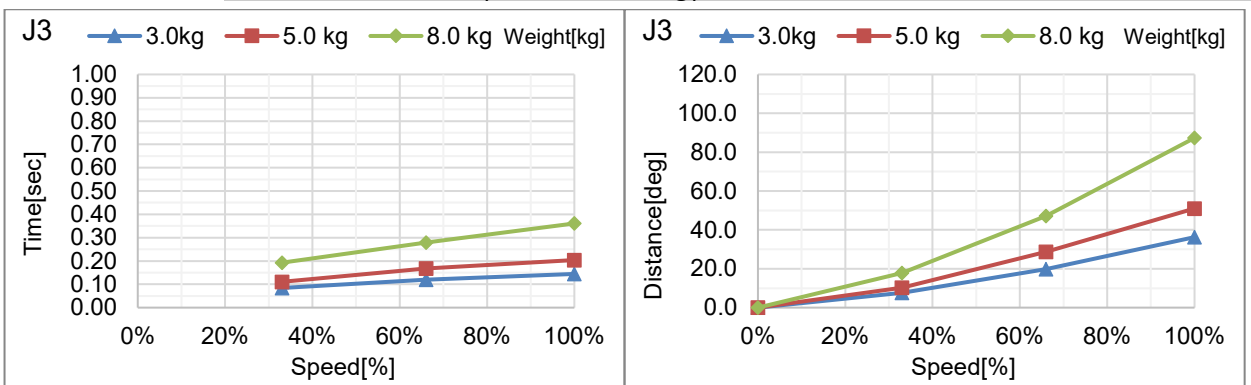

C8-A701***: J4 (Wall mounting)

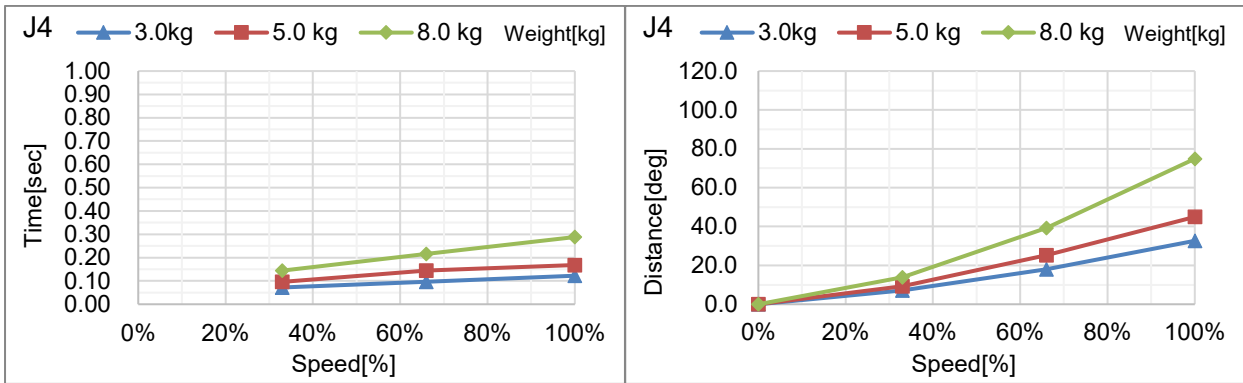

C8-A701***: J5 (Wall mounting)

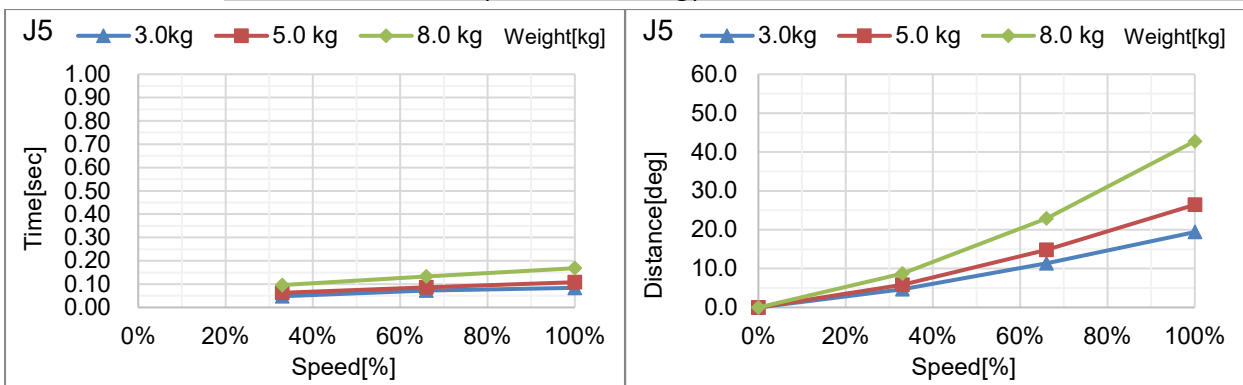

C8-A701***: J6 (Wall mounting)

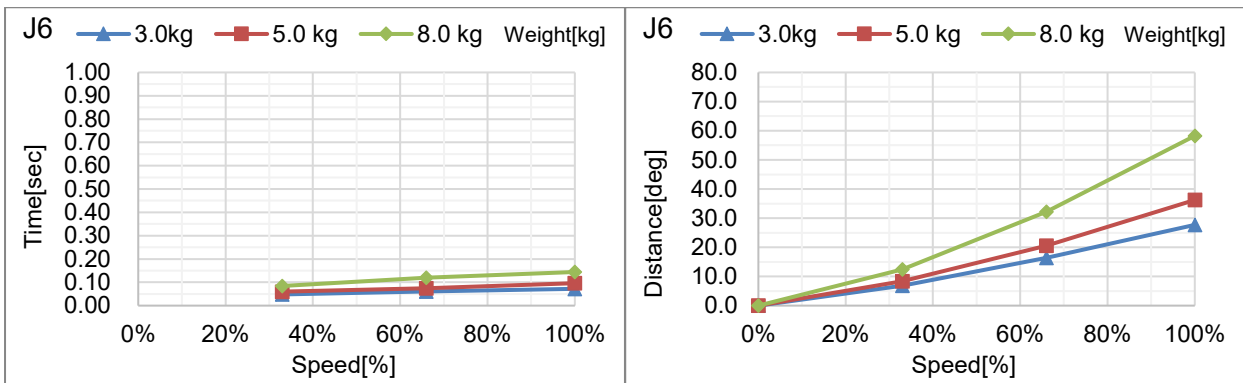

C8-A901***: J1 (Table Top mounting, Ceiling mounting)

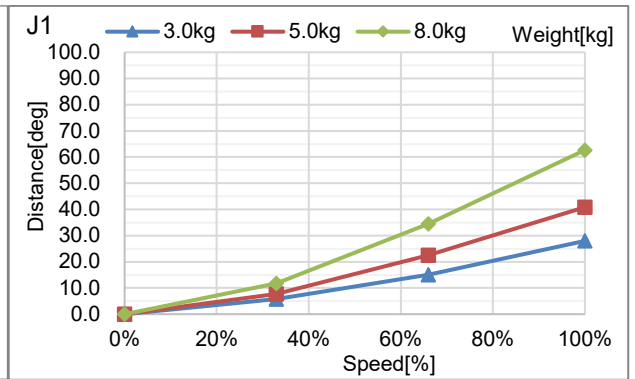
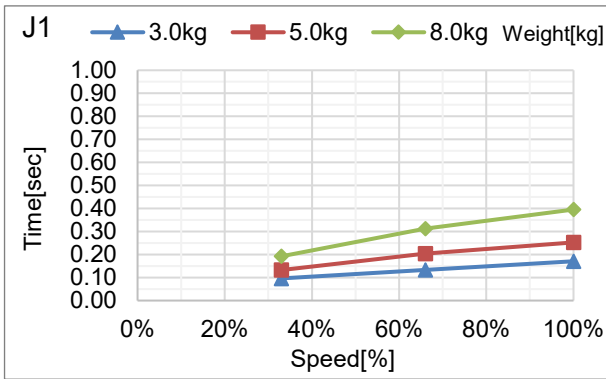

C8-A901***: J2 (Table Top mounting, Ceiling mounting)

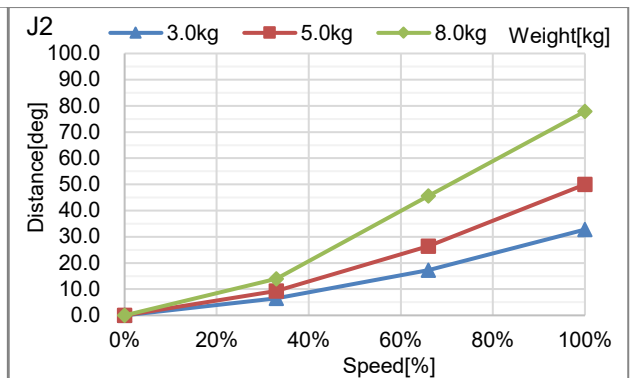
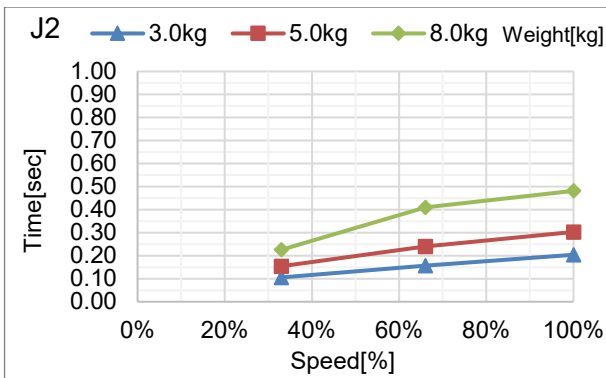

C8-A901***: J3 (Table Top mounting, Ceiling mounting)

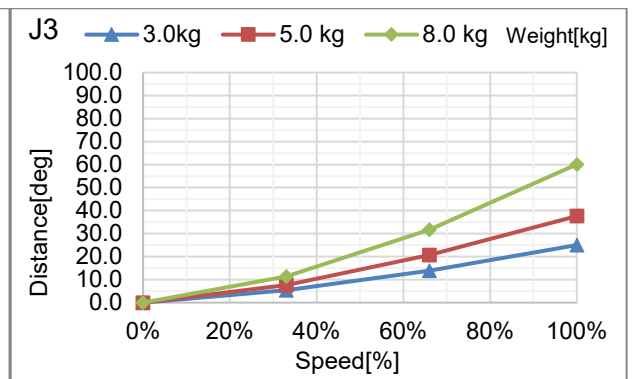
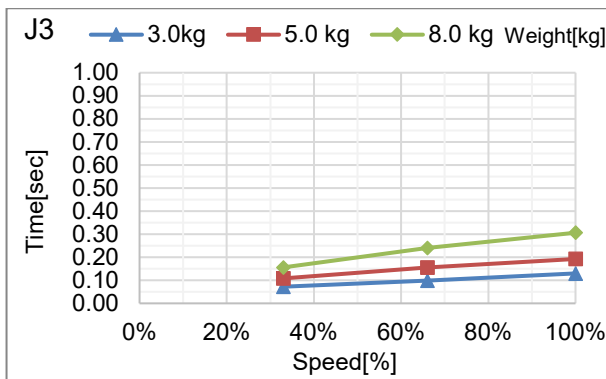

C8-A901***: J4 (Table Top mounting, Ceiling mounting)

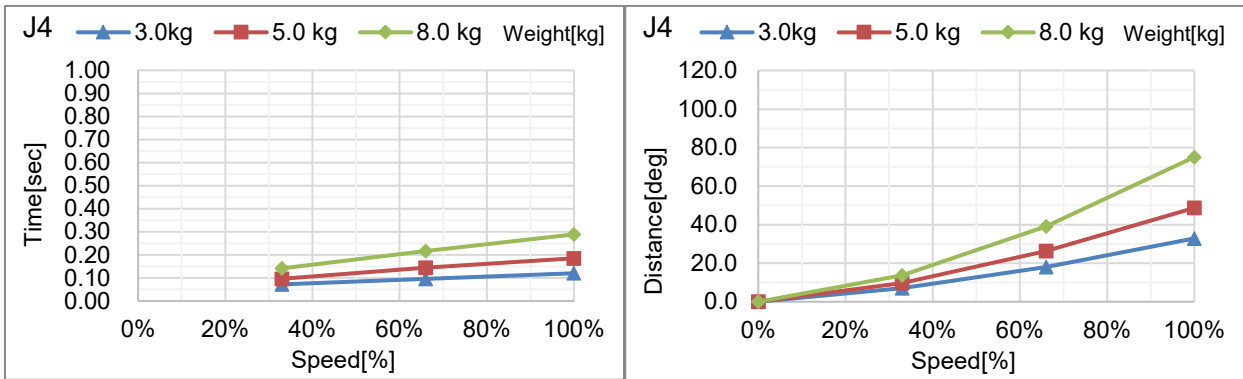

C8-A901***: J5 (Table Top mounting, Ceiling mounting)

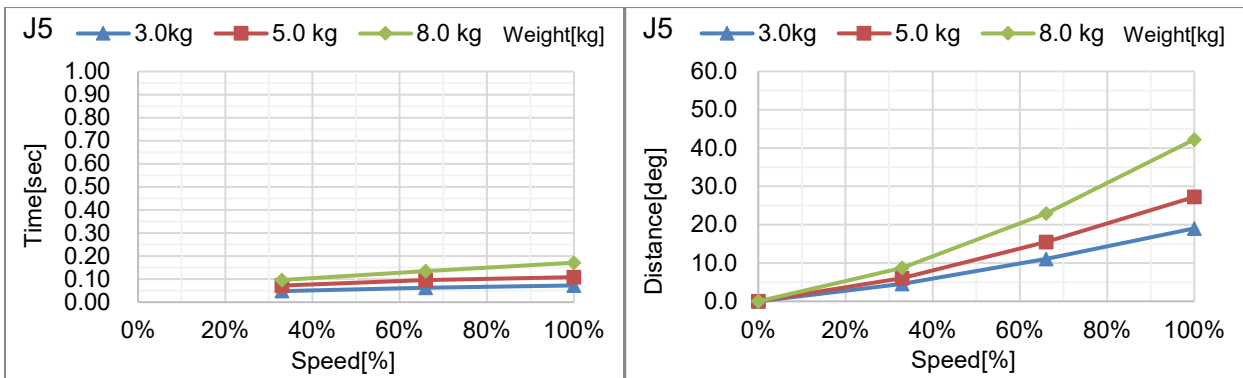

C8-A901***: J6 (Table Top mounting, Ceiling mounting)

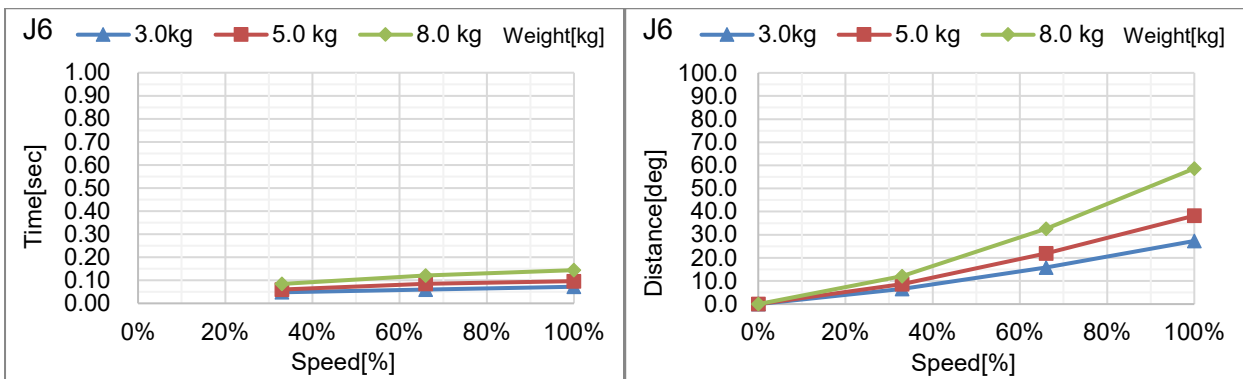

C8-A901***: J1 (Wall mounting)

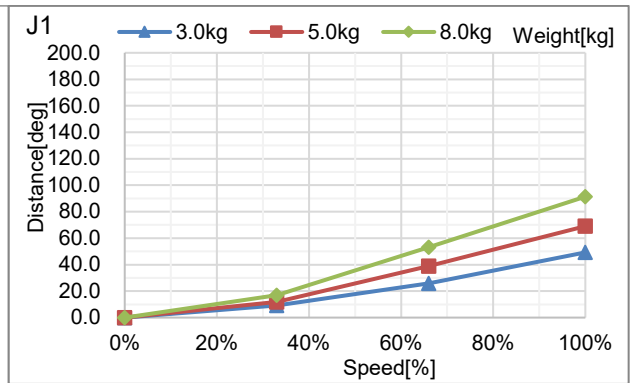
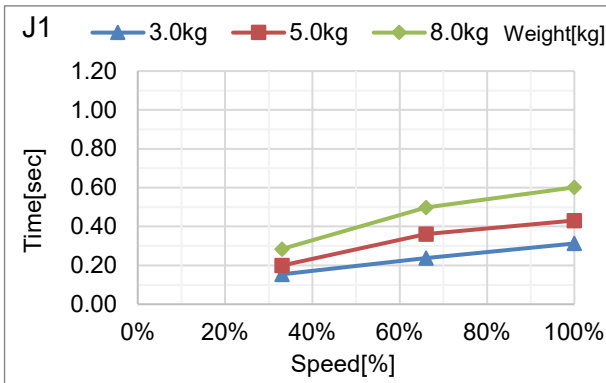

C8-A901***: J2 (Wall mounting)

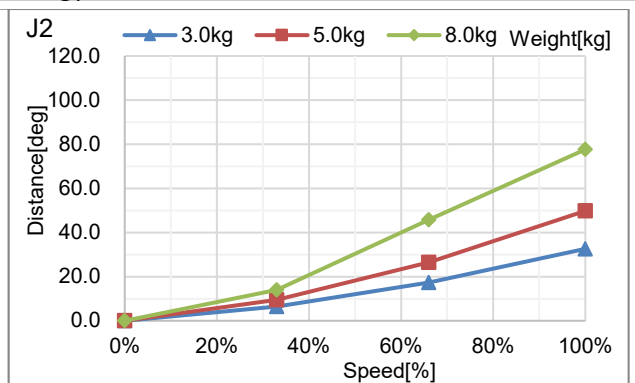
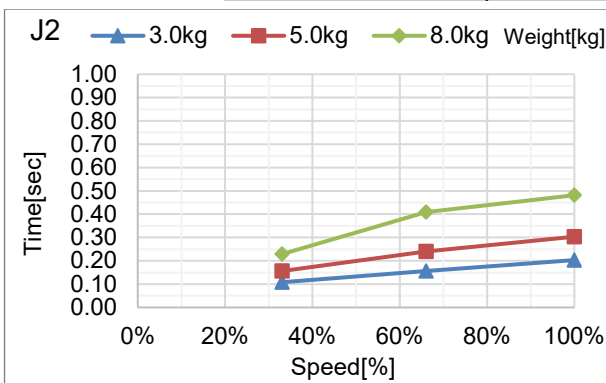

C8-A901***: J3 (Wall mounting)

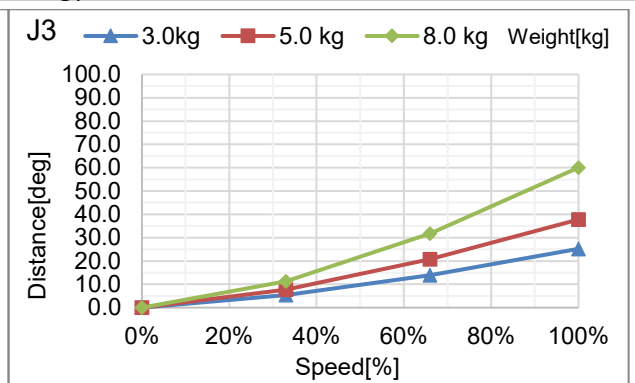
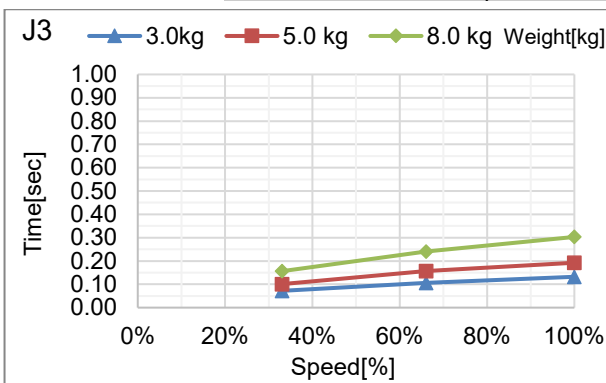

C8-A901***: J4 (Wall mounting)

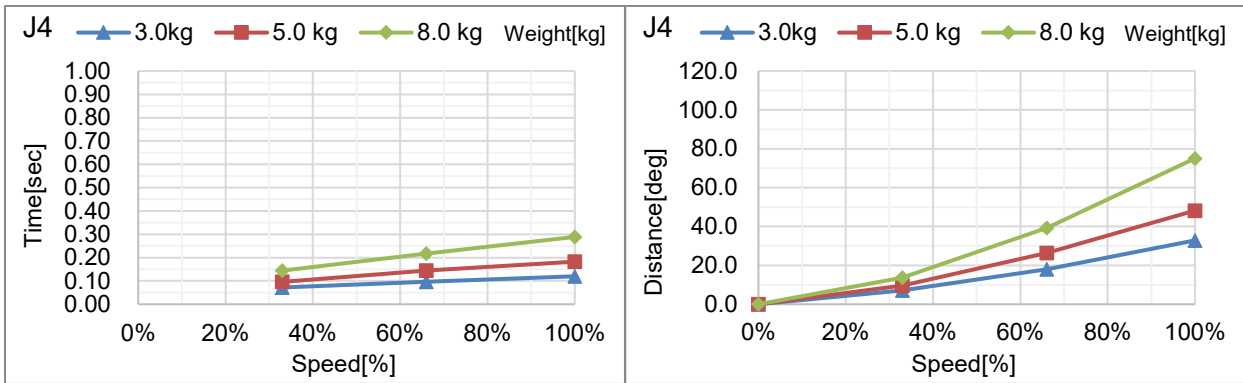

C8-A901***: J5 (Wall mounting)

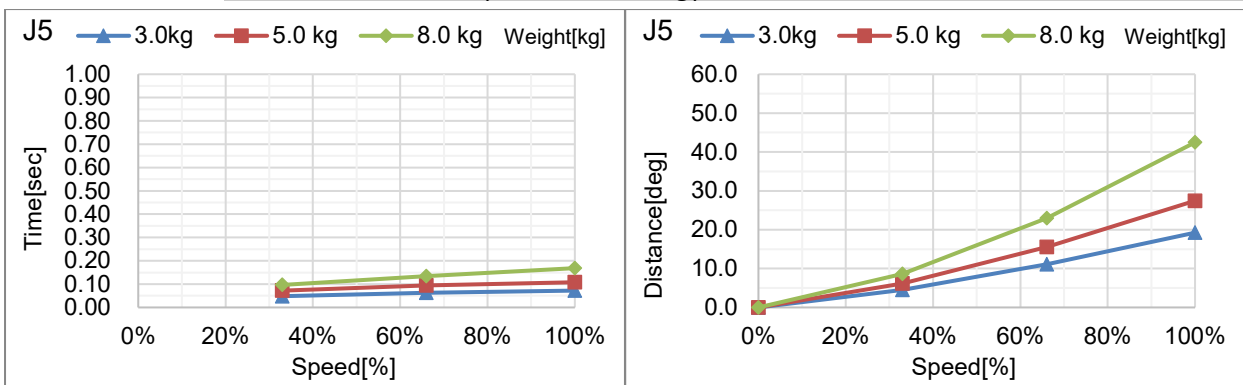

C8-A901***: J6 (Wall mounting)

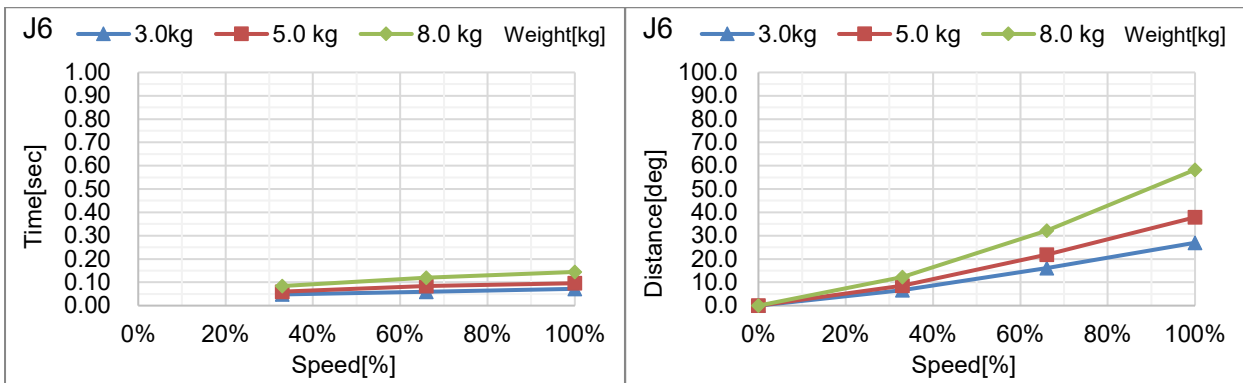

C8-A1401***: J1 (Table Top mounting, Ceiling mounting)

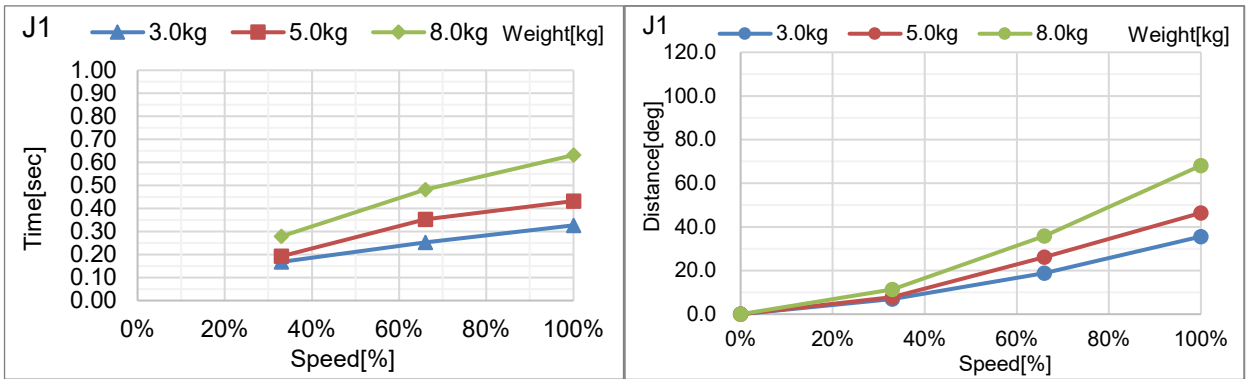

C8-A1401***: J2 (Table Top mounting, Ceiling mounting)

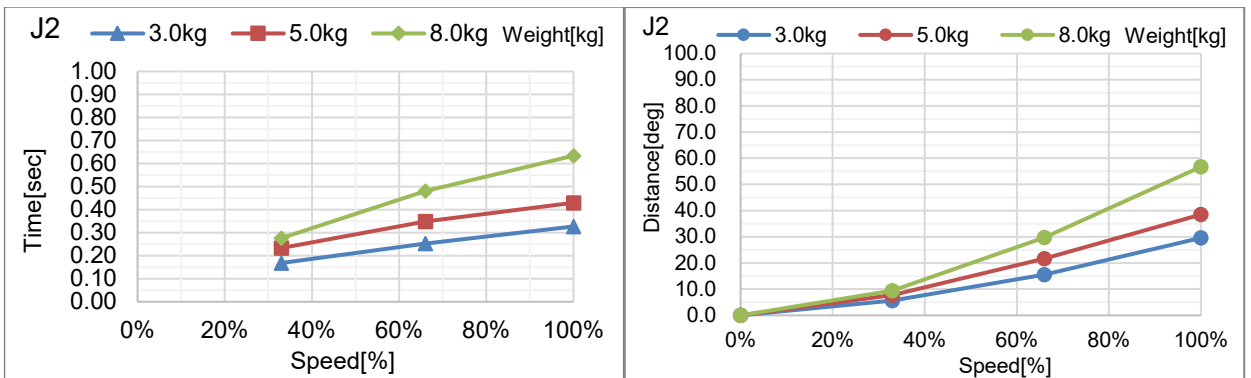

C8-A1401***: J3 (Table Top mounting, Ceiling mounting)

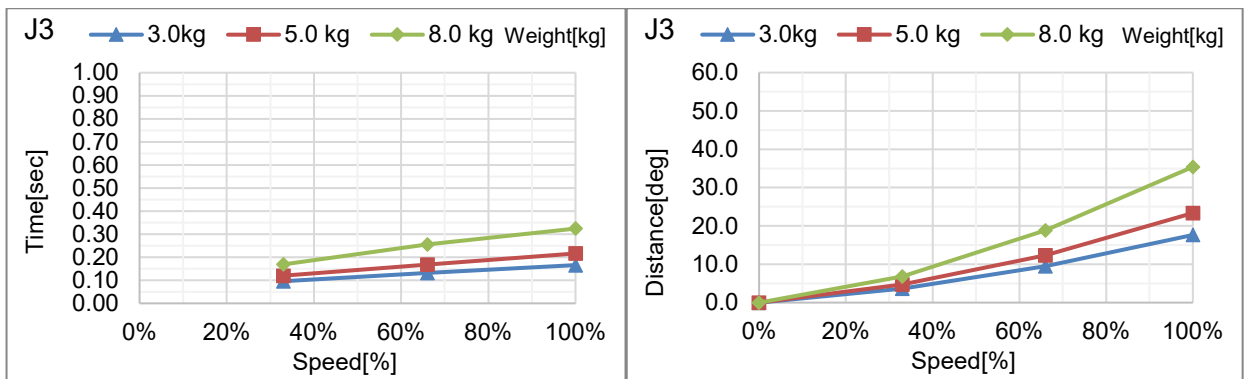

C8-A1401***: J4 (Table Top mounting, Ceiling mounting)

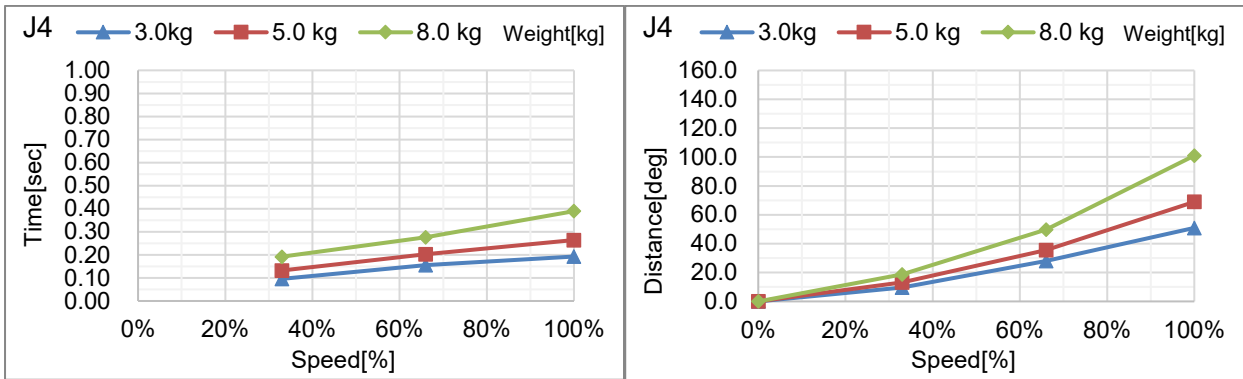

C8-A1401***: J5 (Table Top mounting, Ceiling mounting)

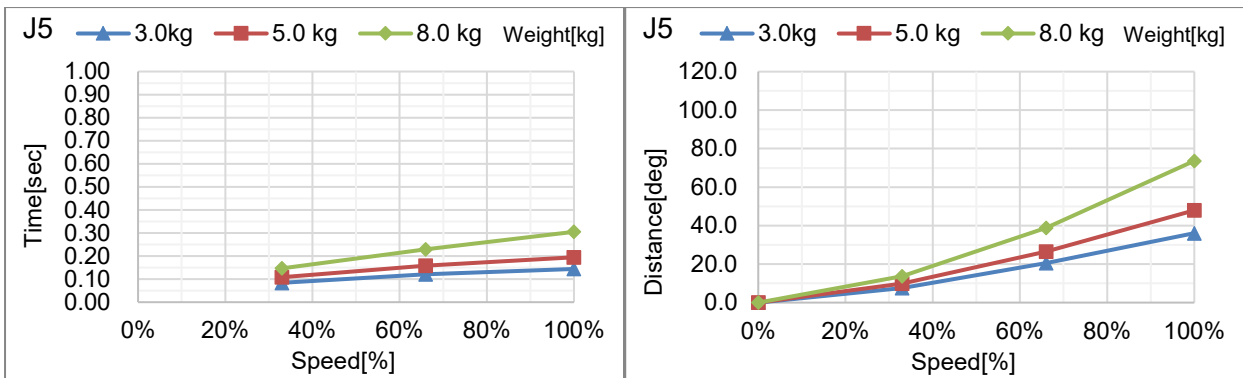

C8-A1401***: J6 (Table Top mounting, Ceiling mounting)

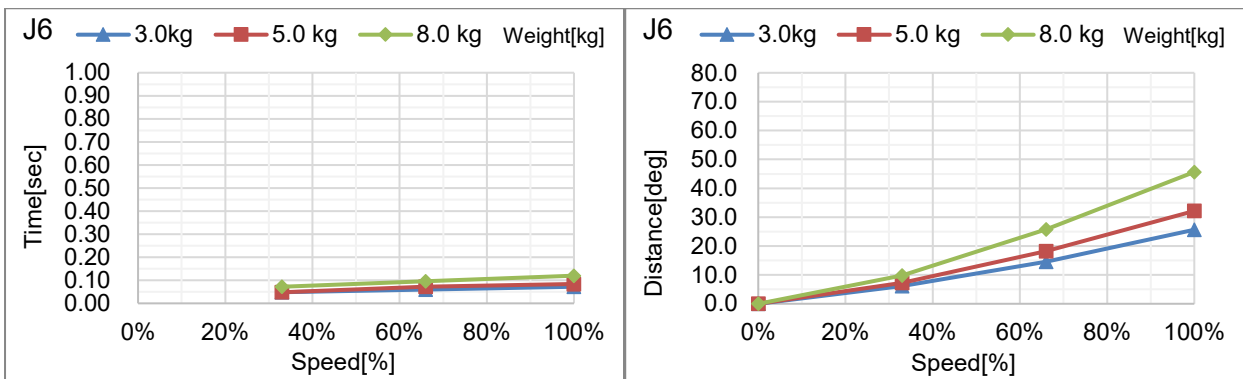

C8-A1401***: J1 (Wall mounting)

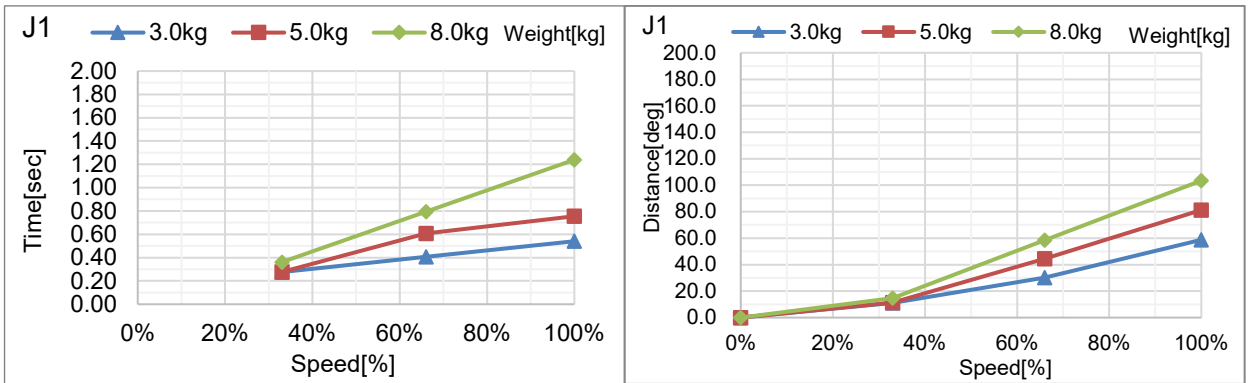

C8-A1401***: J2 (Wall mounting)

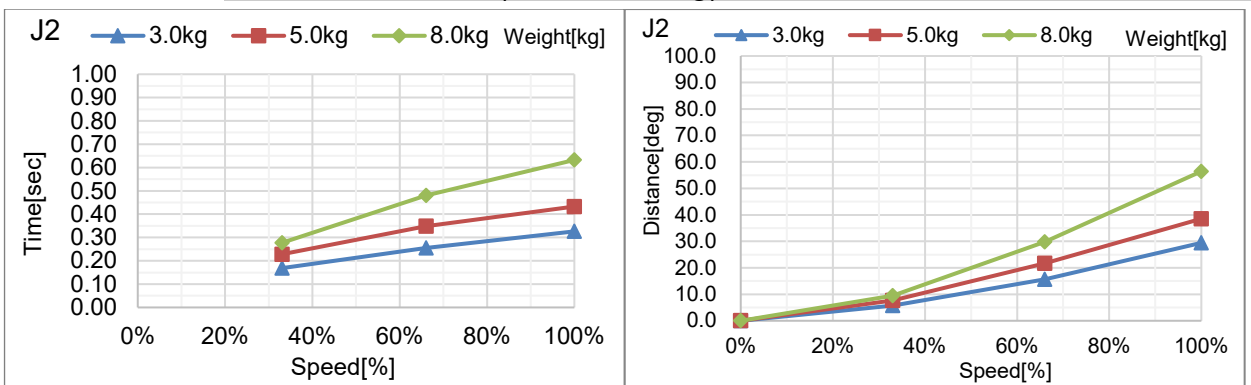

C8-A1401***: J3 (Wall mounting)

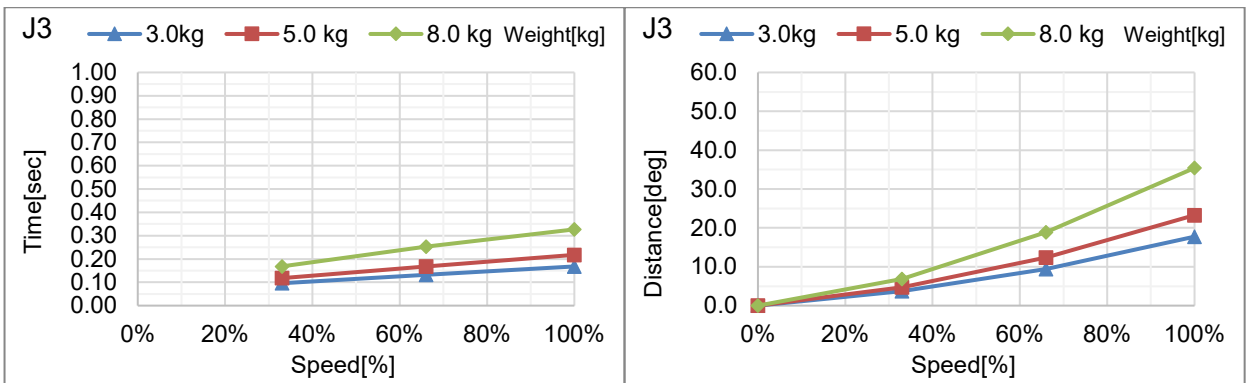

C8-A1401***: J4 (Wall mounting)

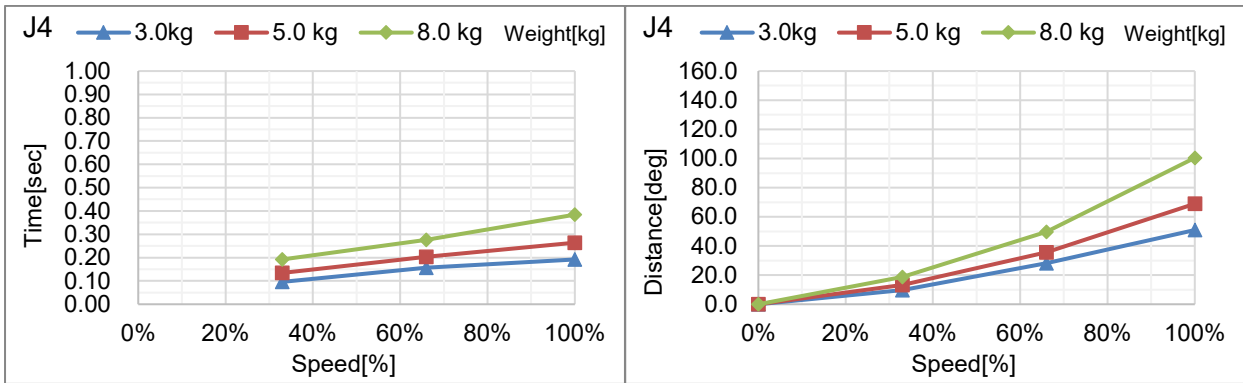

C8-A1401***: J5 (Wall mounting)

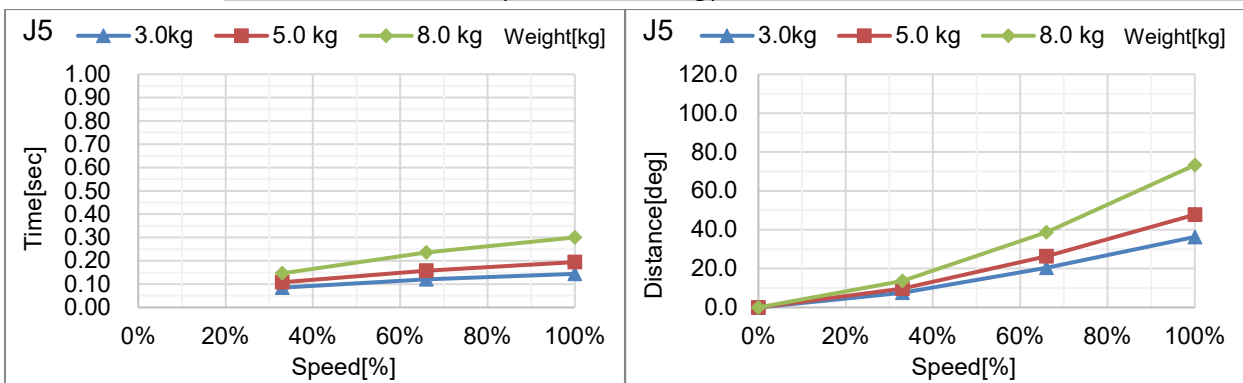

C8-A1401***: J6 (Wall mounting)

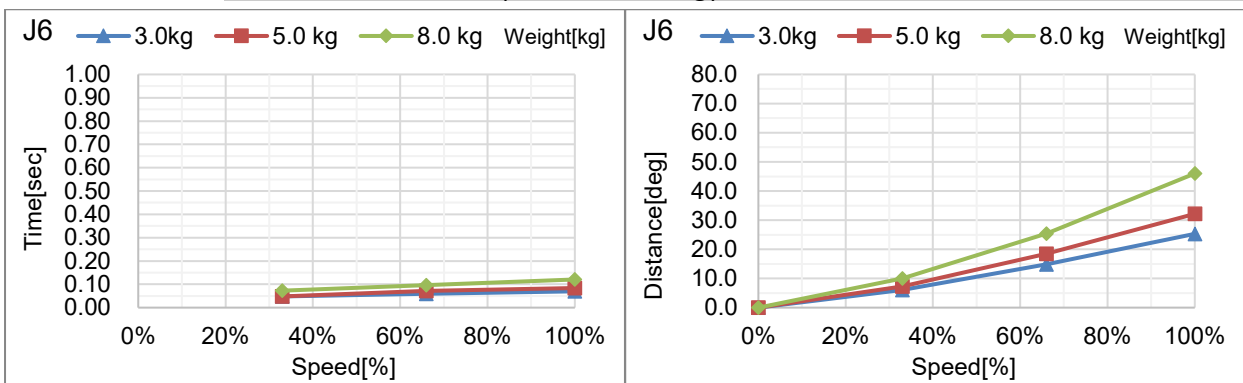

C12 Stopping time and Stopping distance in Emergency

C12-A1401**: J1 (Table Top mounting)

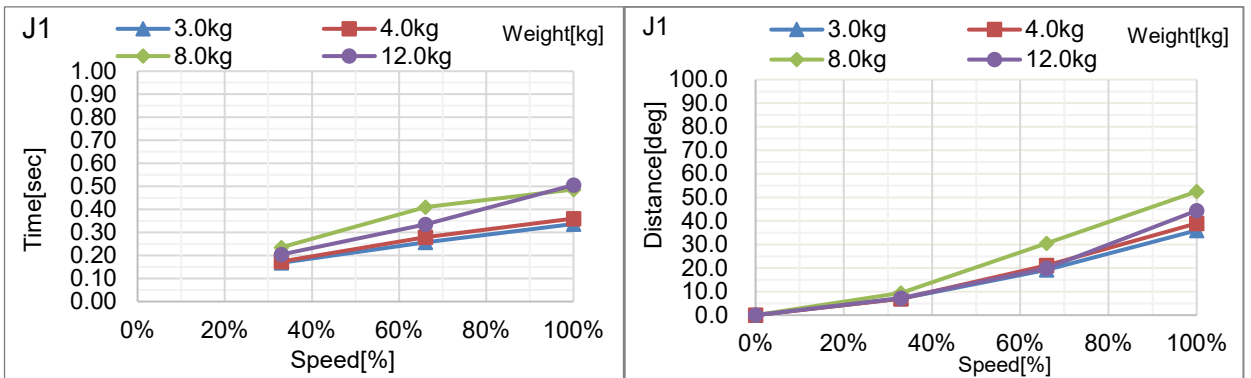

C12-A1401**: J2 (Table Top mounting)

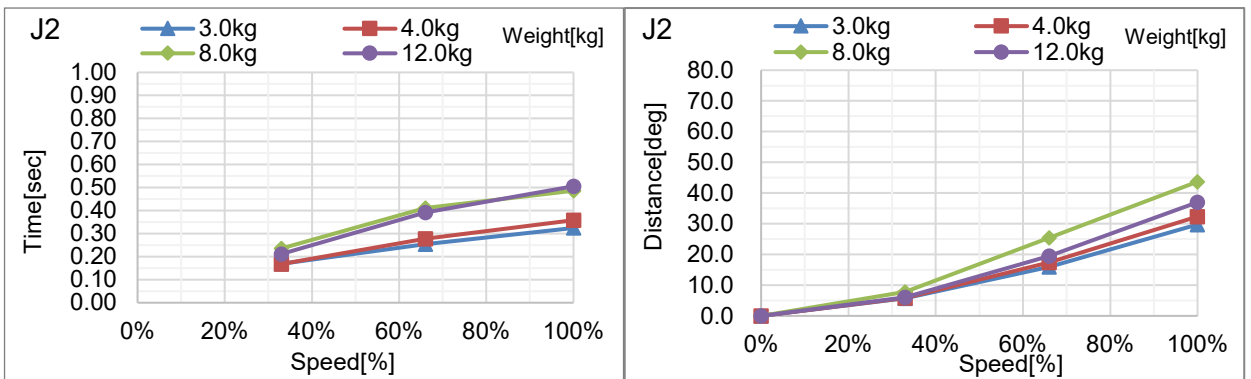

C12-A1401**: J3 (Table Top mounting)

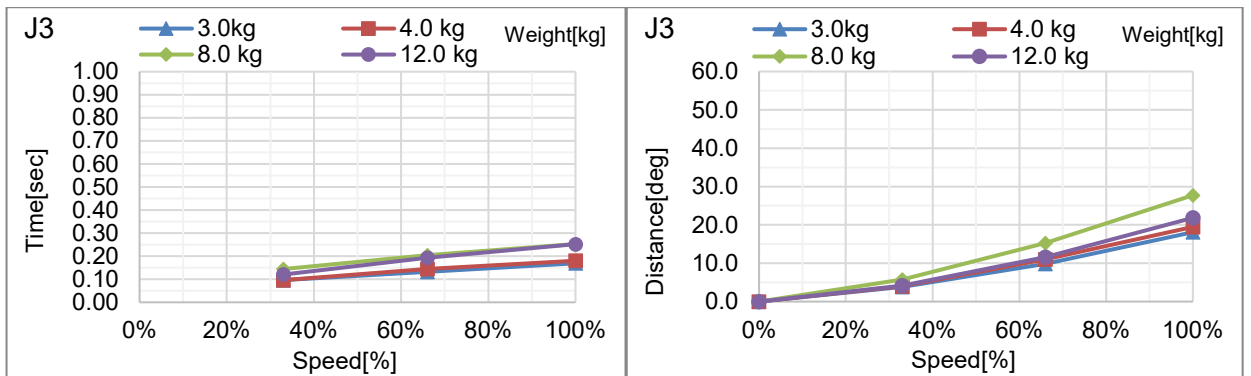

C12-A1401**: J4 (Table Top mounting)

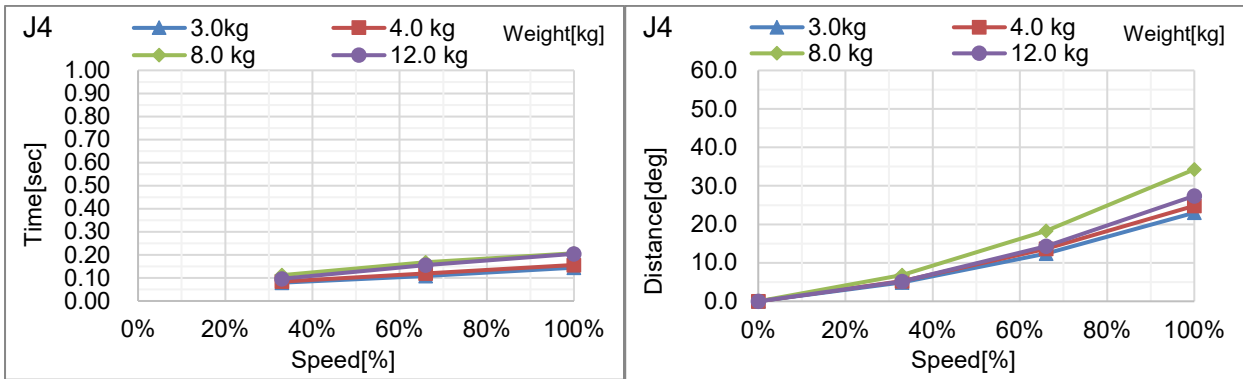

C12-A1401**: J5 (Table Top mounting)

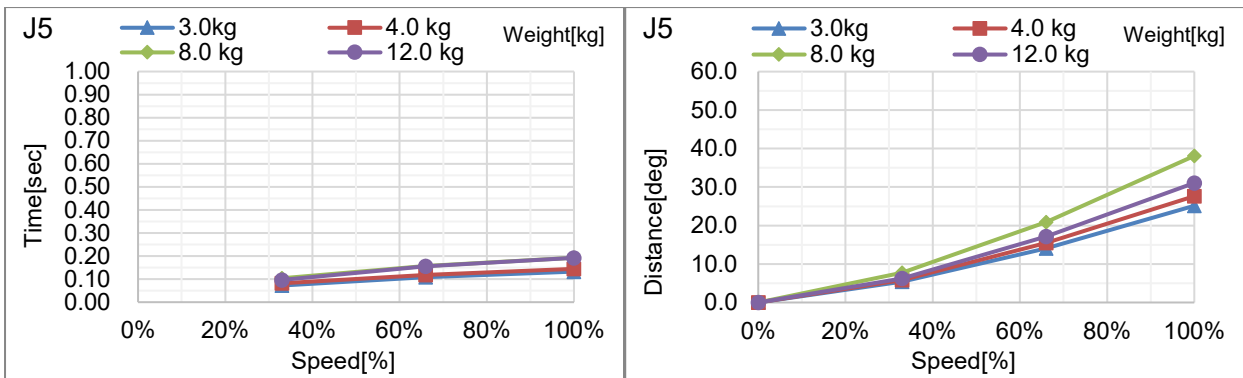

C12-A1401**: J6 (Table Top mounting)

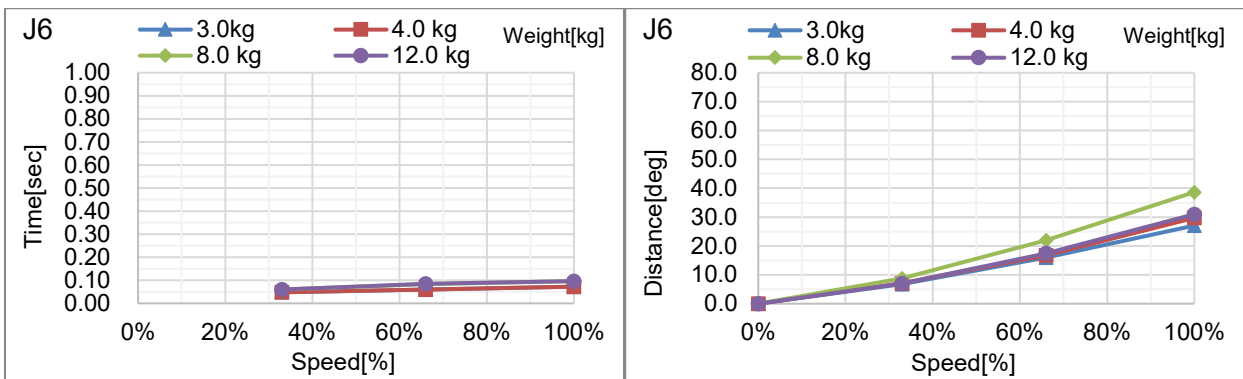

Appendix C: Stopping time and Stopping distance When Safeguard Is Opened

The stopping time and stopping distance when safeguard is opened are shown in a graph for each model.

The stopping time is “Stopping time” in the figure below. Be sure to confirm that safety is ensured according to the installation environment and operation of the robot.

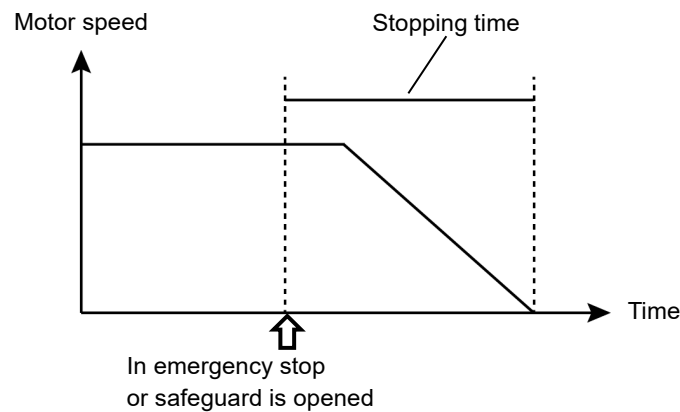

Condition :

The stopping time and stopping distance vary depending on the parameters (setting value) set for the robot. In this chapter, the time and distance are shown with the following parameters.

Accel : 100 ,100

Other : Default

Description of legend:

The graph is shown for each Weight value (rated value, 100%, about 66%, and about 33% of the maximum payload).

Horizontal axis : Arm speed (Speed value)

Vertical axis : Stopping time and stopping distance in each arm speed

Time [sec] : Stopping time

Distance [deg] : Stopping distance

C4 Stopping time and Stopping distance When Safeguard Is Opened

C4-A601**: J1 (Table Top mounting, Ceiling mounting)

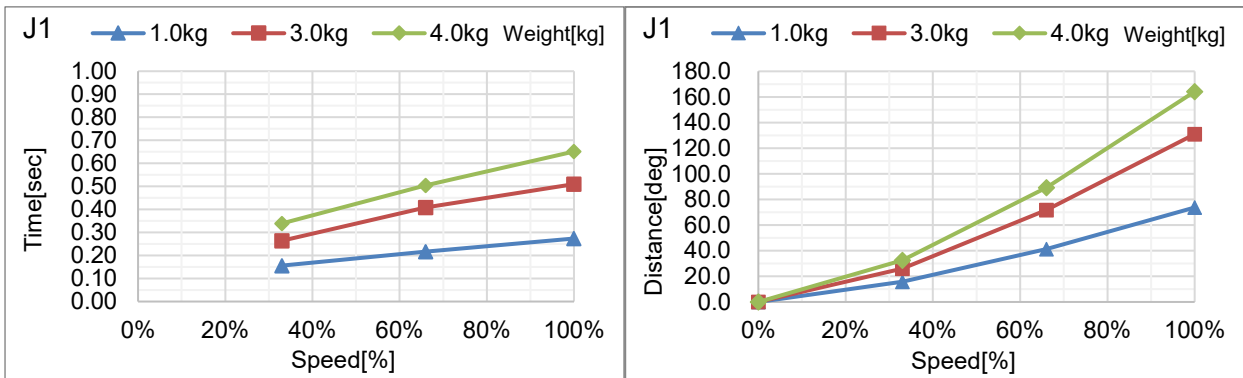

C4-A601**: J2 (Table Top mounting, Ceiling mounting)

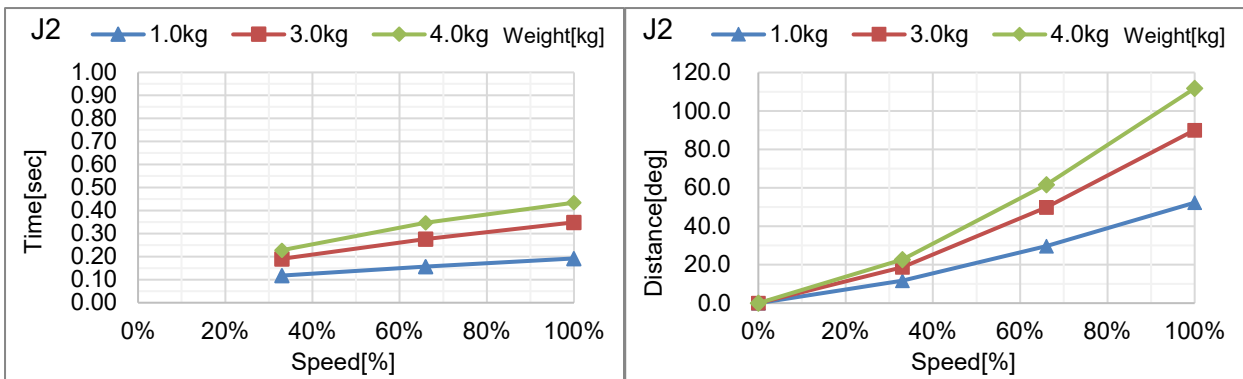

C4-A601**: J3 (Table Top mounting, Ceiling mounting)

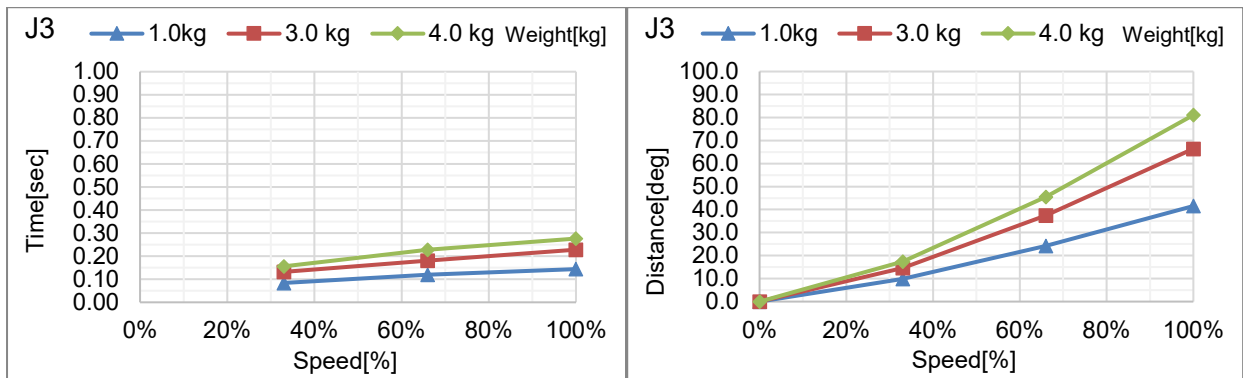

C4-A601**: J4 (Table Top mounting, Ceiling mounting)

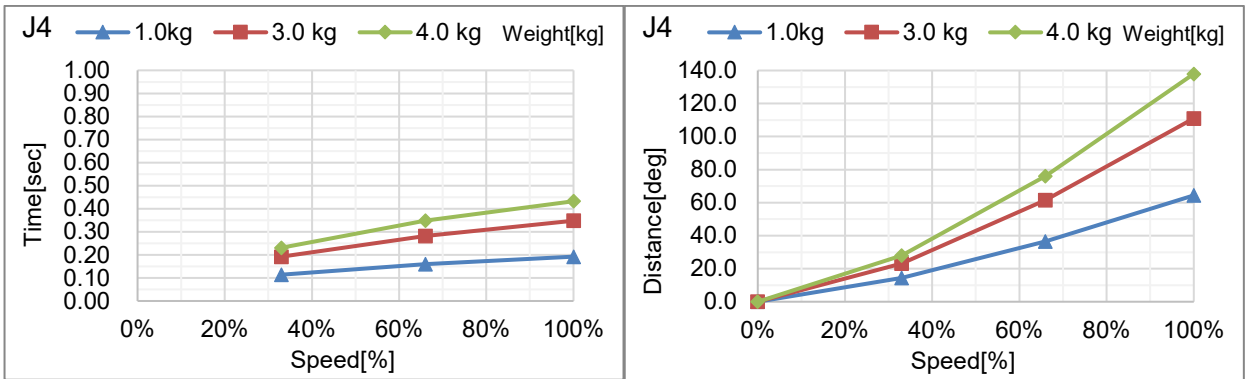

C4-A601**: J5 (Table Top mounting, Ceiling mounting)

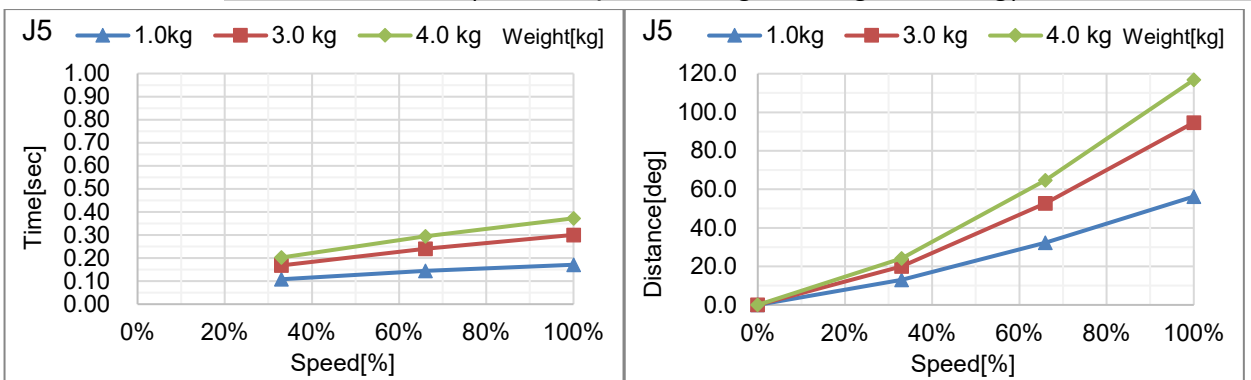

C4-A601**: J6 (Table Top mounting, Ceiling mounting)

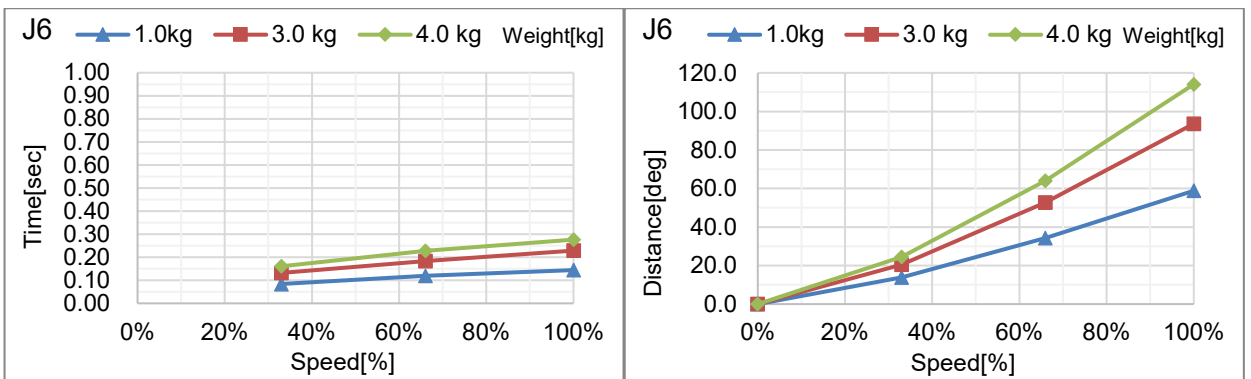

C4-A901**: J1 (Table Top mounting, Ceiling mounting)

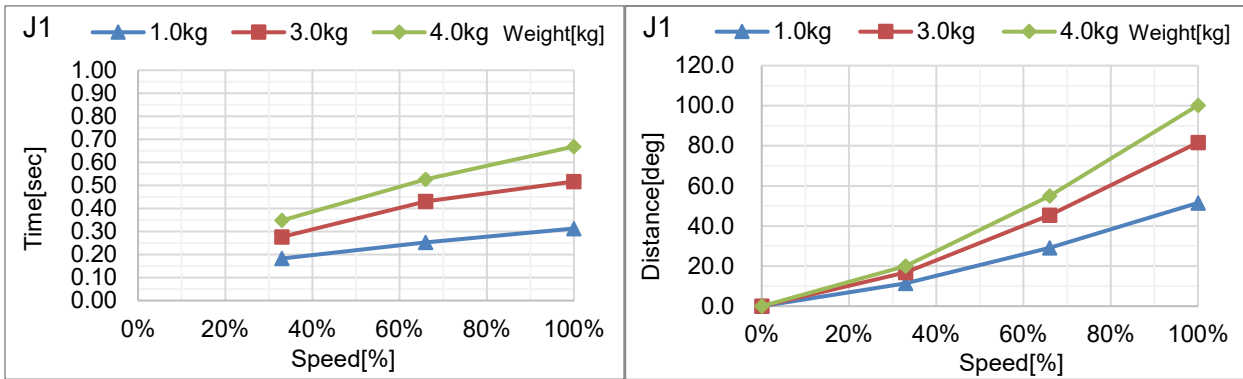

C4-A901**: J2 (Table Top mounting, Ceiling mounting)

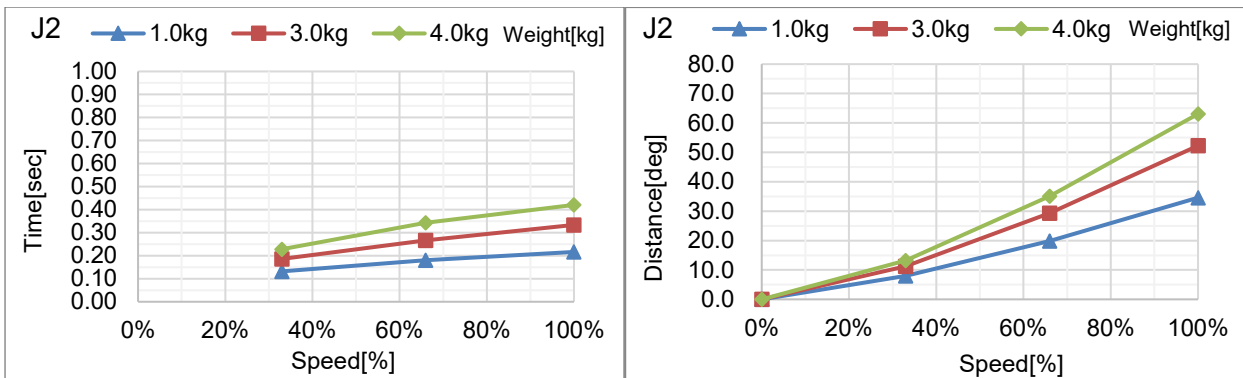

C4-A901**: J3 (Table Top mounting, Ceiling mounting)

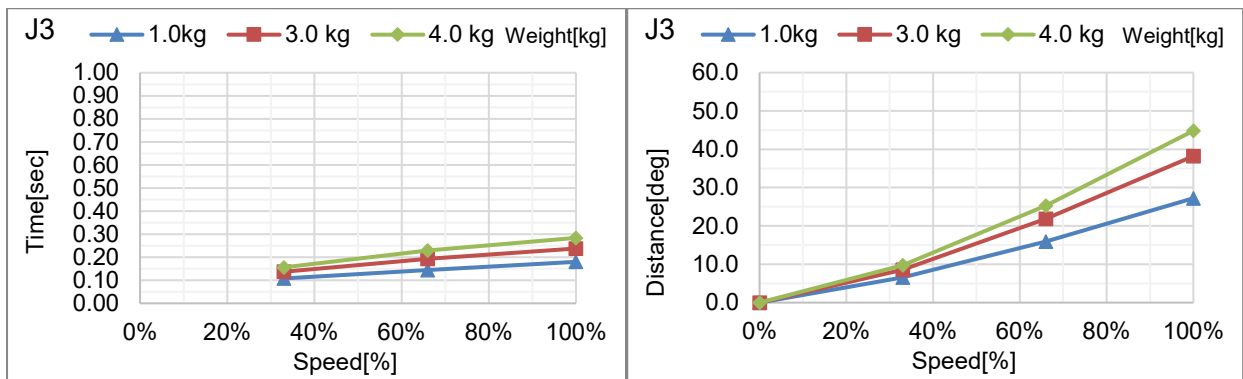

C4-A901**: J4 (Table Top mounting, Ceiling mounting)

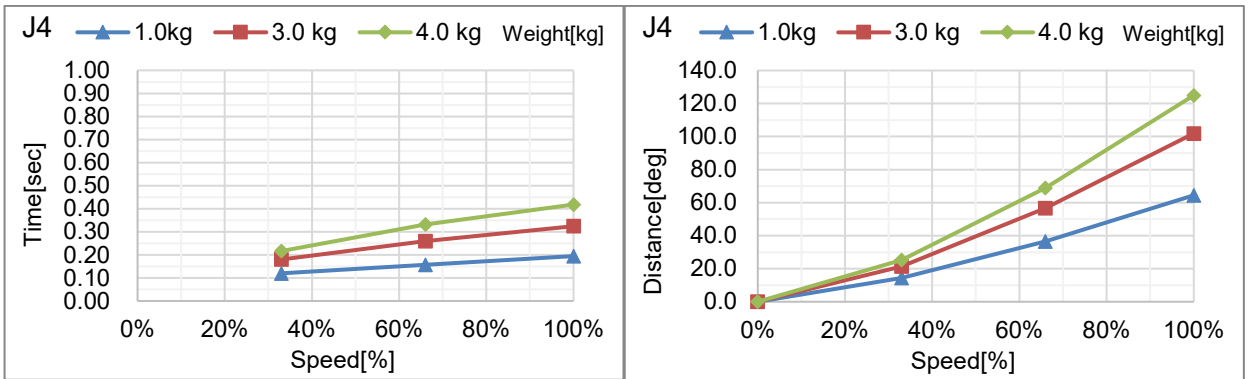

C4-A901**: J5 (Table Top mounting, Ceiling mounting)

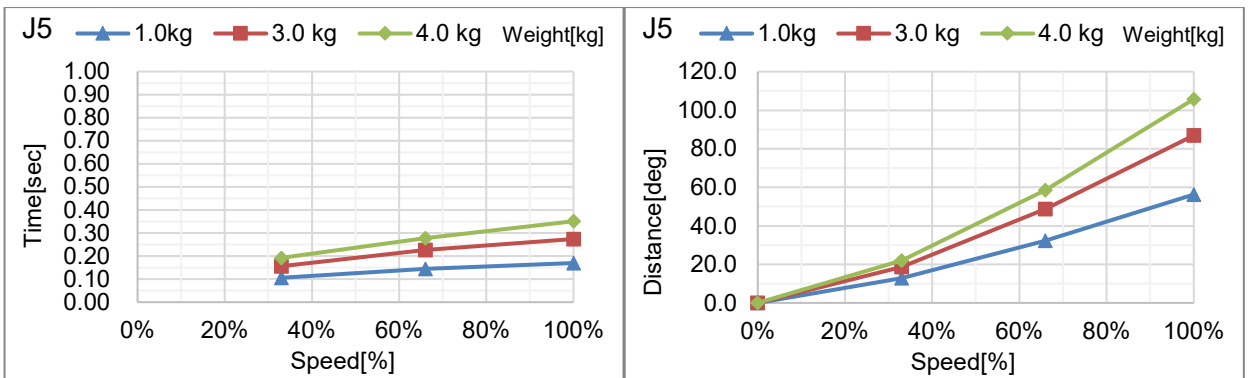

C4-A901**: J6 (Table Top mounting, Ceiling mounting)

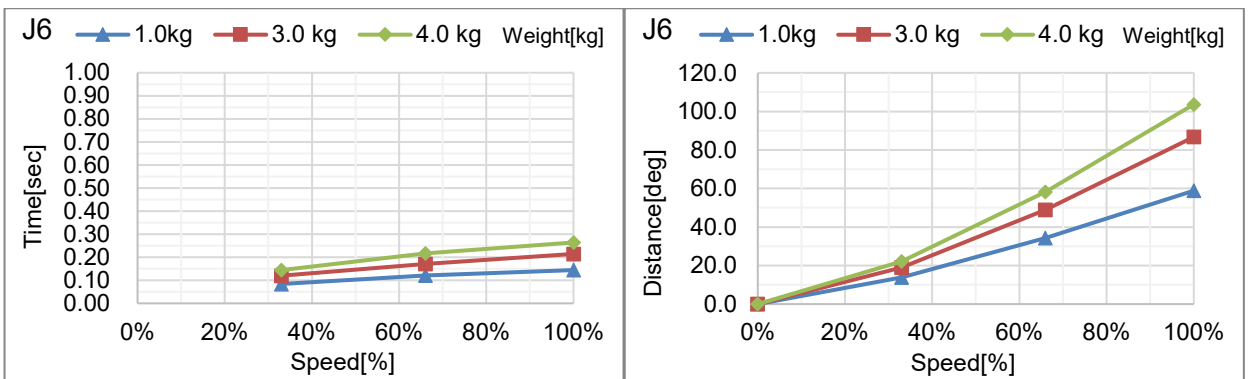

C8 Stopping time and Stopping distance When Safeguard Is Opened

C8-A701***: J1 (Table Top mounting, Ceiling mounting)

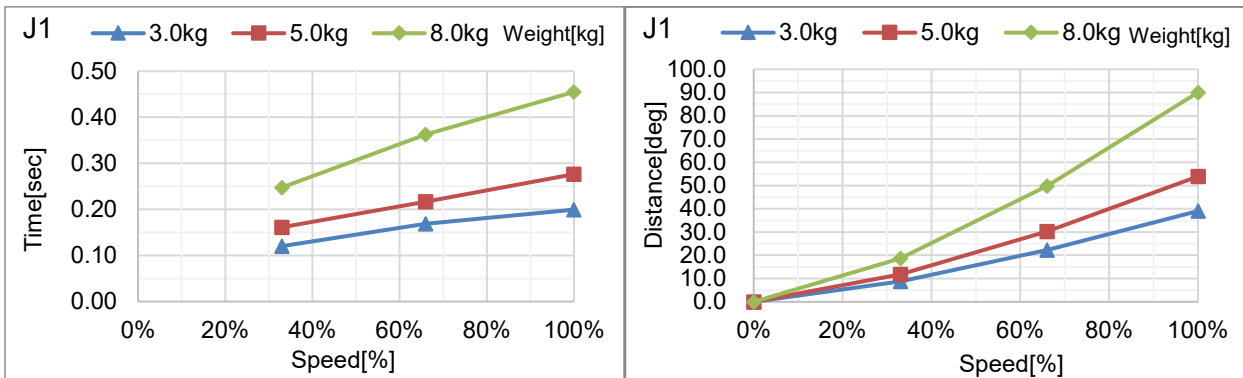

C8-A701***: J2 (Table Top mounting, Ceiling mounting)

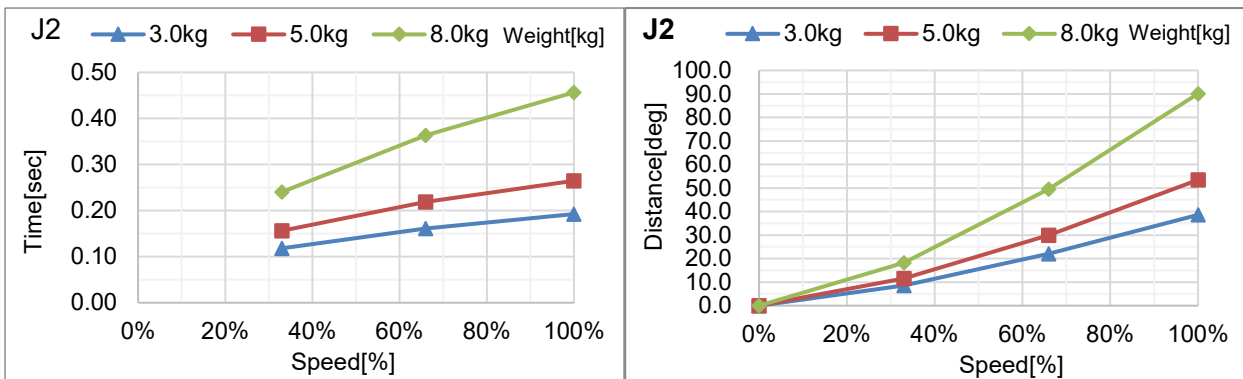

C8-A701***: J3 (Table Top mounting, Ceiling mounting)

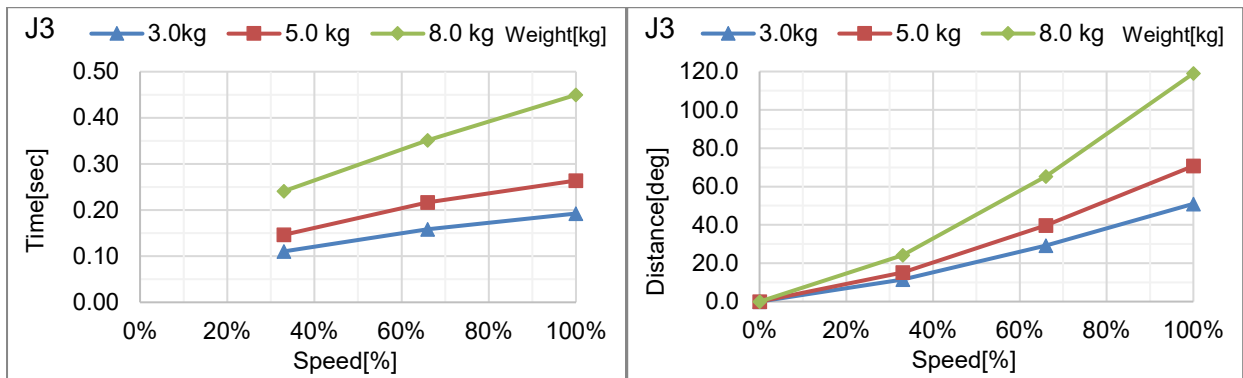

C8-A701***: J4 (Table Top mounting, Ceiling mounting)

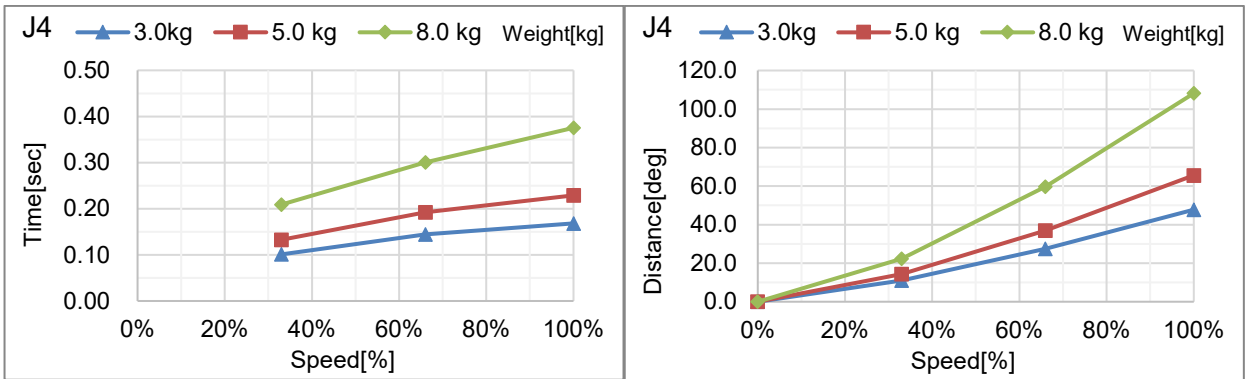

C8-A701***: J5 (Table Top mounting, Ceiling mounting)

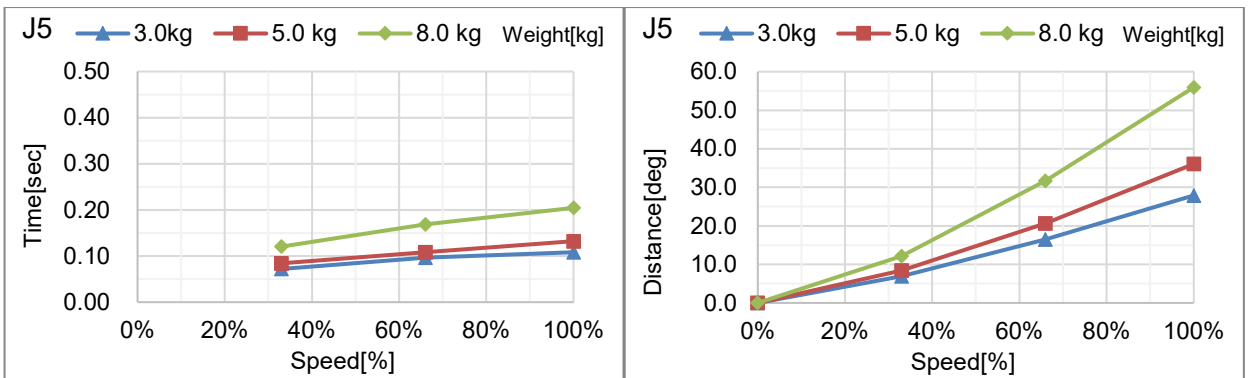

C8-A701***: J6 (Table Top mounting, Ceiling mounting)

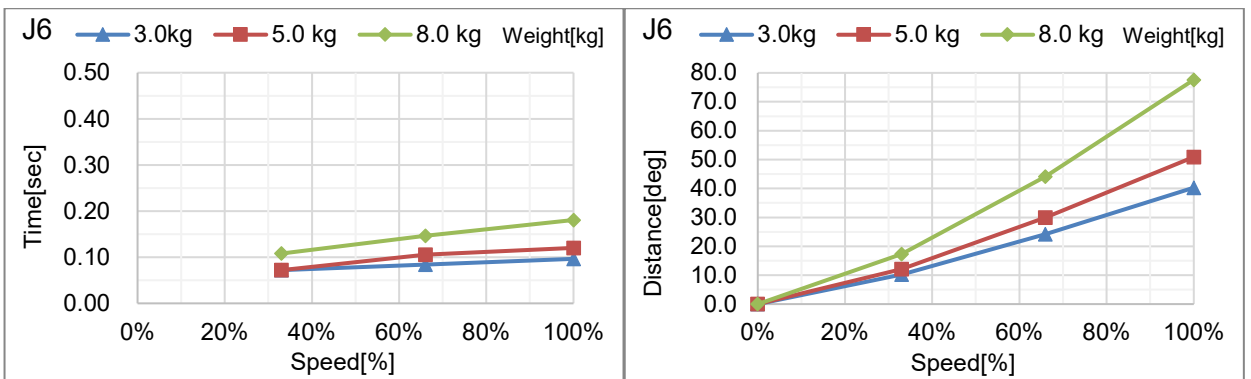

C8-A701***: J1 (Wall mounting)

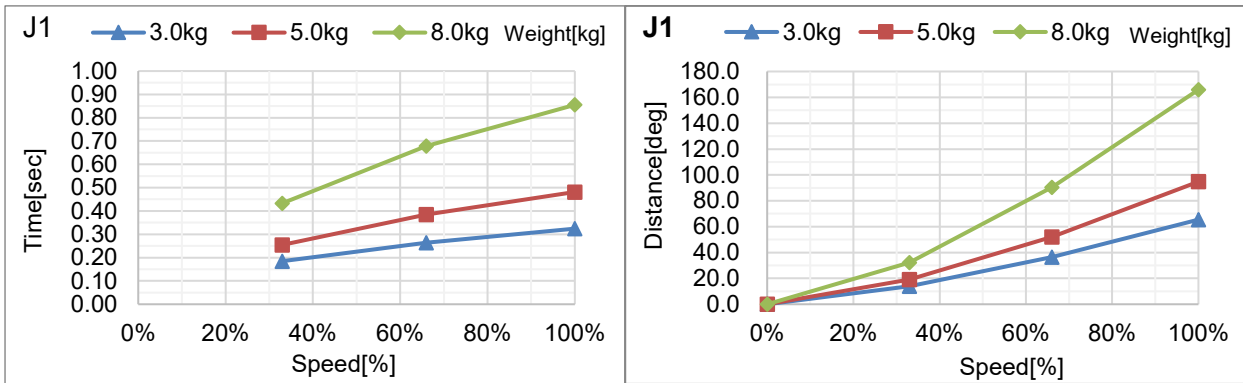

C8-A701***: J2 (Wall mounting)

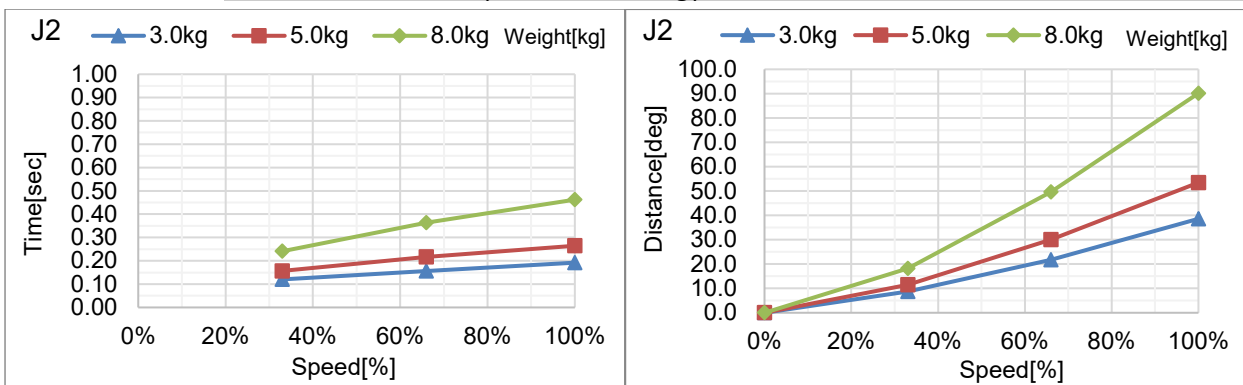

C8-A701***: J3 (Wall mounting)

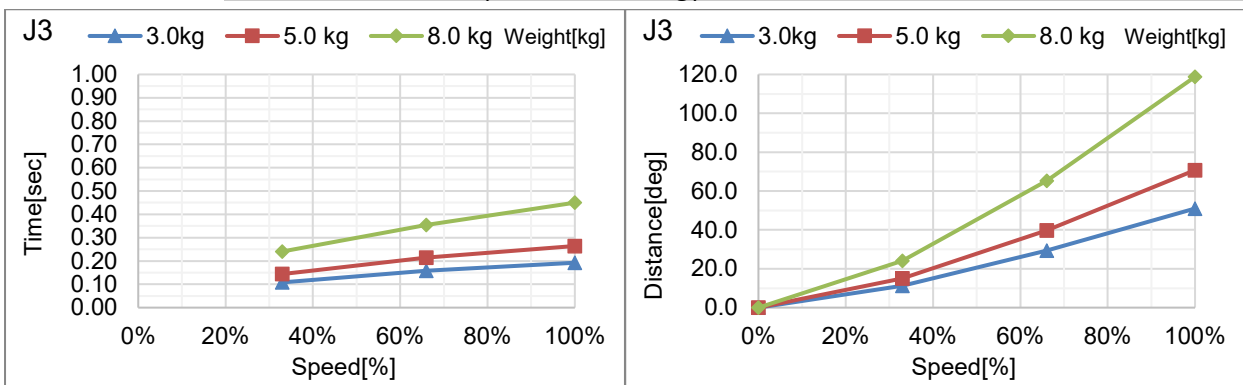

C8-A701***: J4 (Wall mounting)

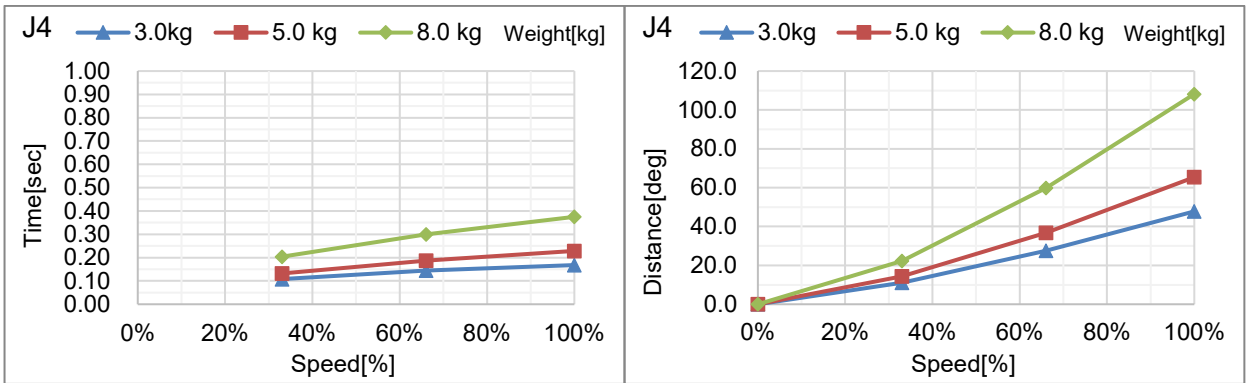

C8-A701***: J5 (Wall mounting)

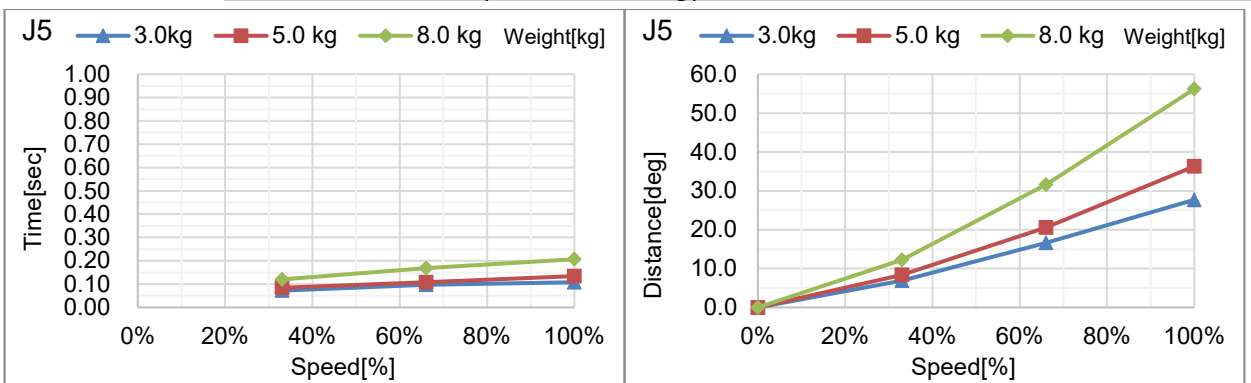

C8-A701***: J6 (Wall mounting)

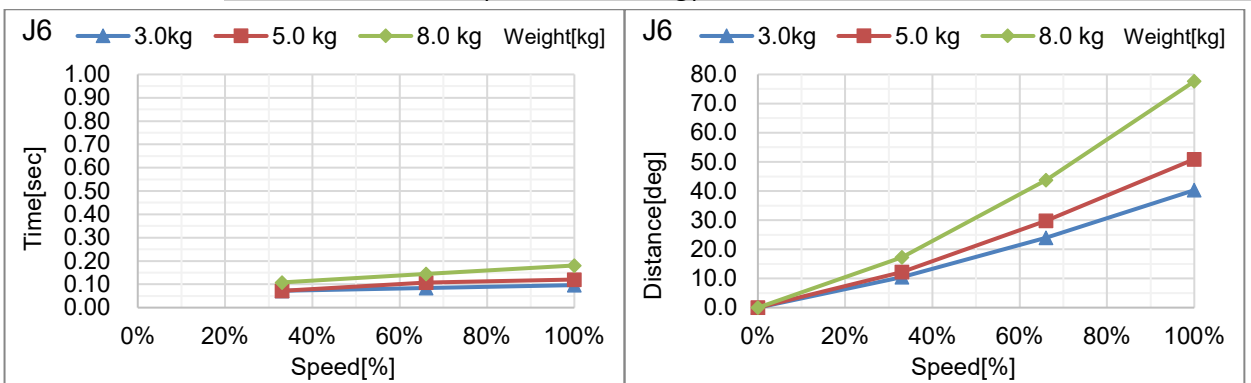

C8-A901***: J1 (Table Top mounting, Ceiling mounting)

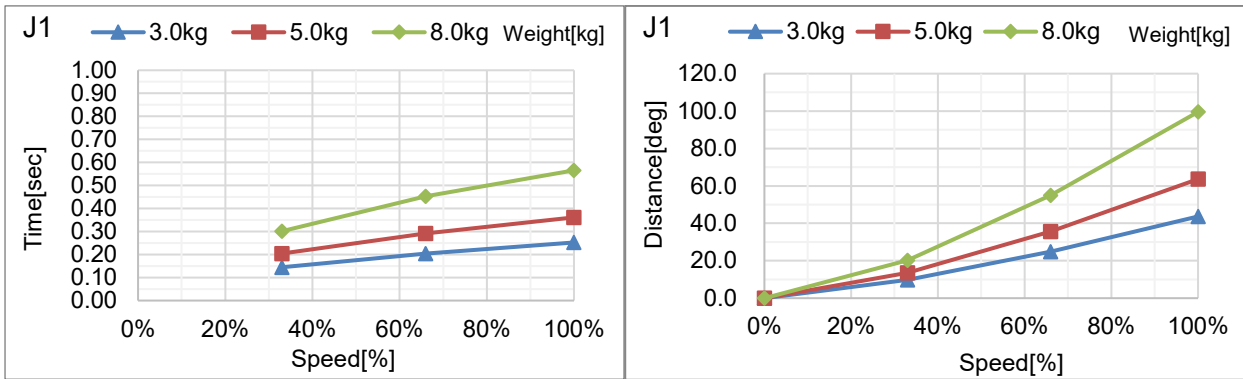

C8-A901***: J2 (Table Top mounting, Ceiling mounting)

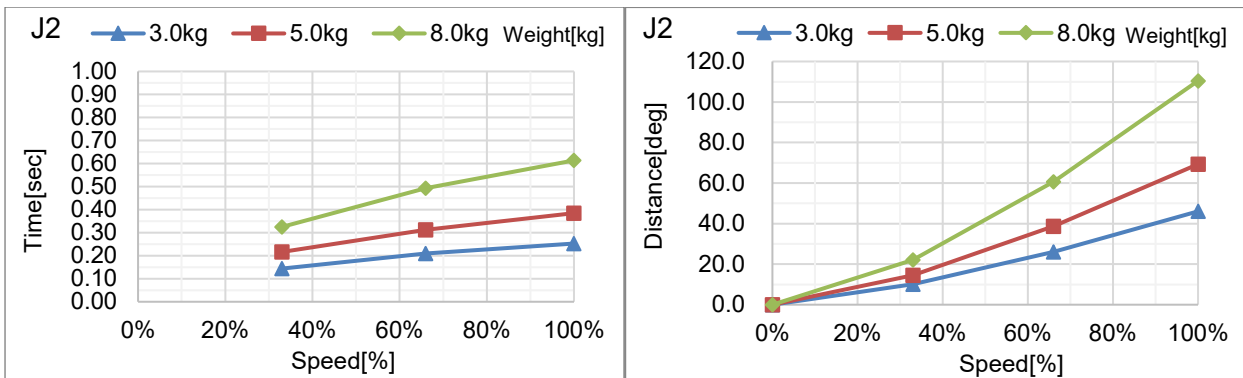

C8-A901***: J3 (Table Top mounting, Ceiling mounting)

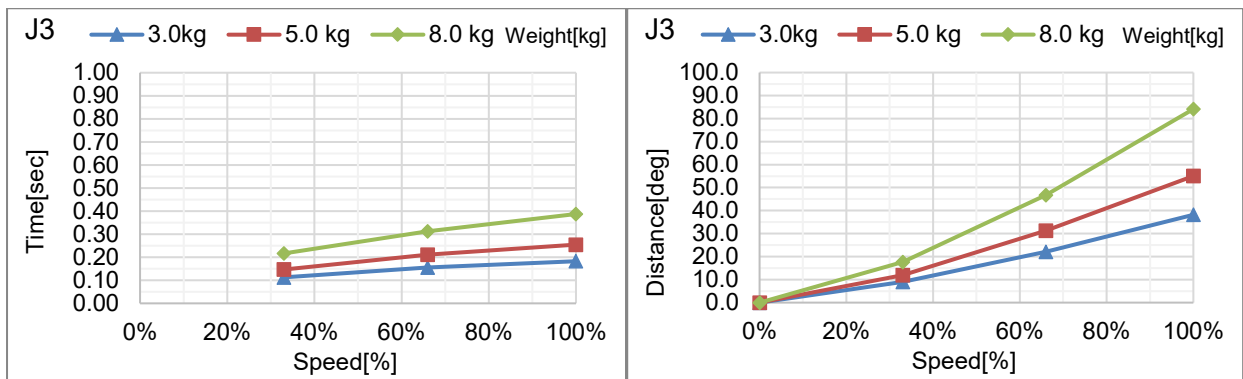

C8-A901***: J4 (Table Top mounting, Ceiling mounting)

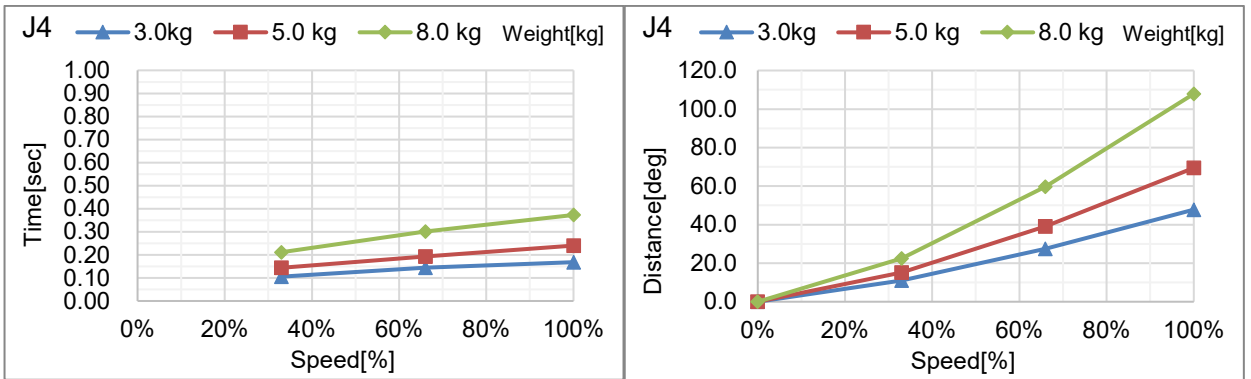

C8-A901***: J5 (Table Top mounting, Ceiling mounting)

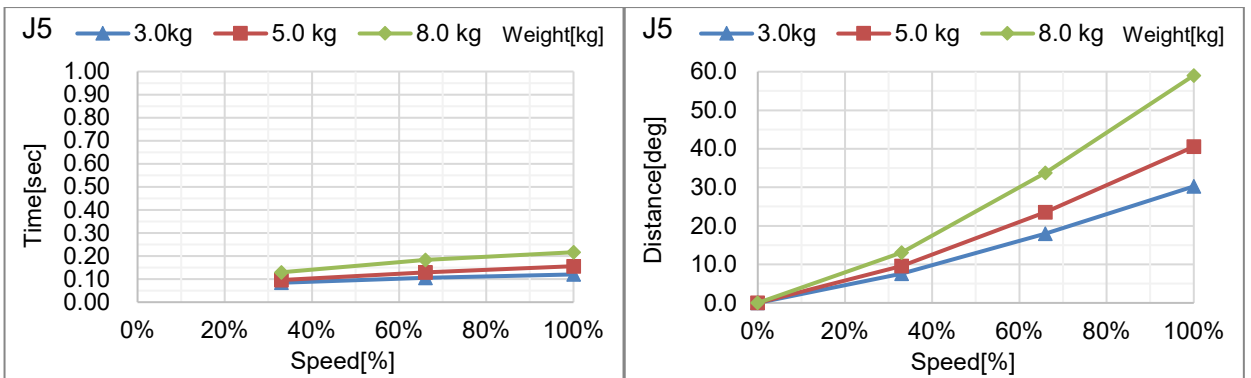

C8-A901***: J6 (Table Top mounting, Ceiling mounting)

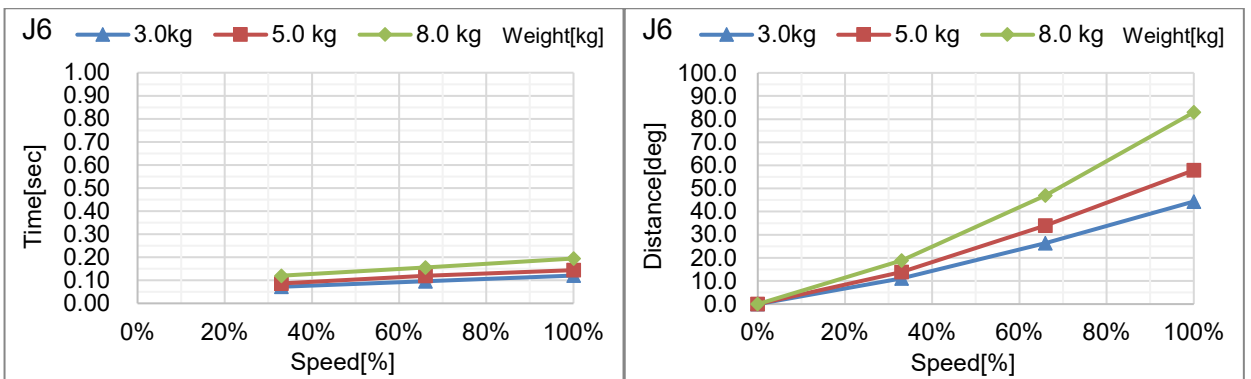

C8-A901***: J1 (Wall mounting)

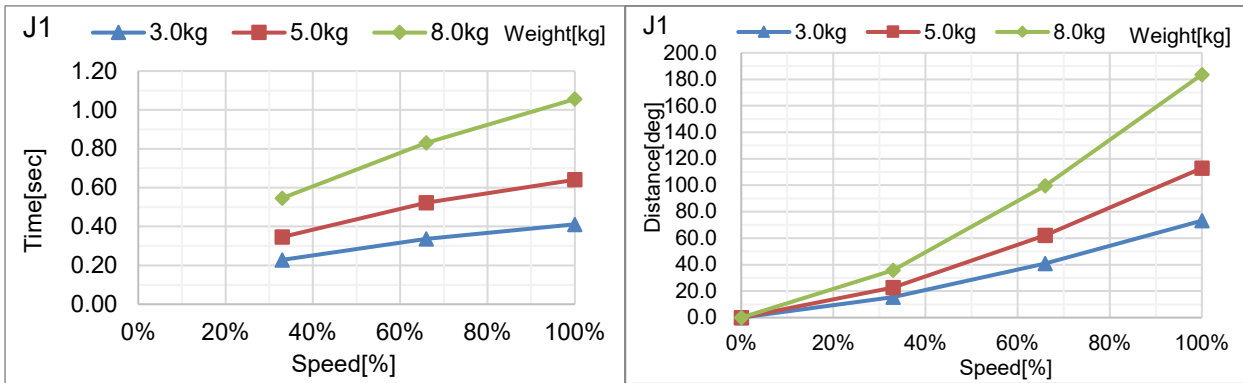

C8-A901***: J2 (Wall mounting)

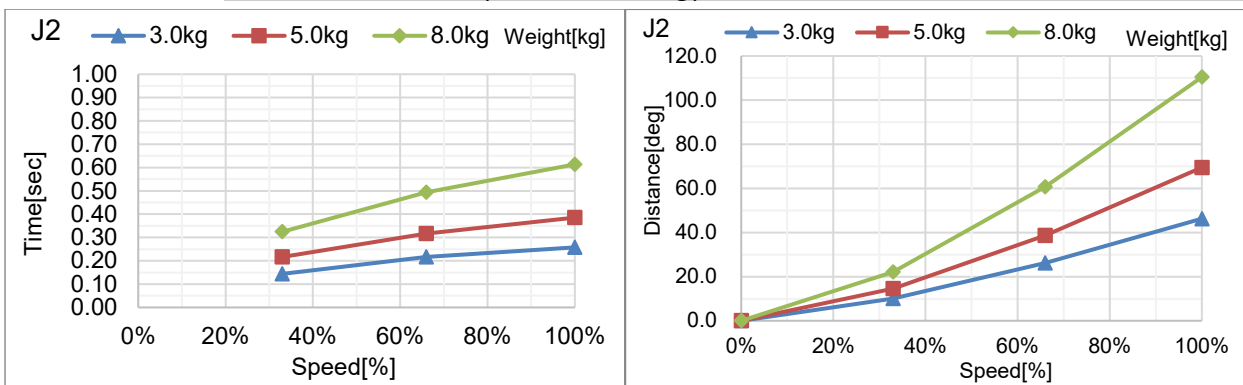

C8-A901***: J3 (Wall mounting)

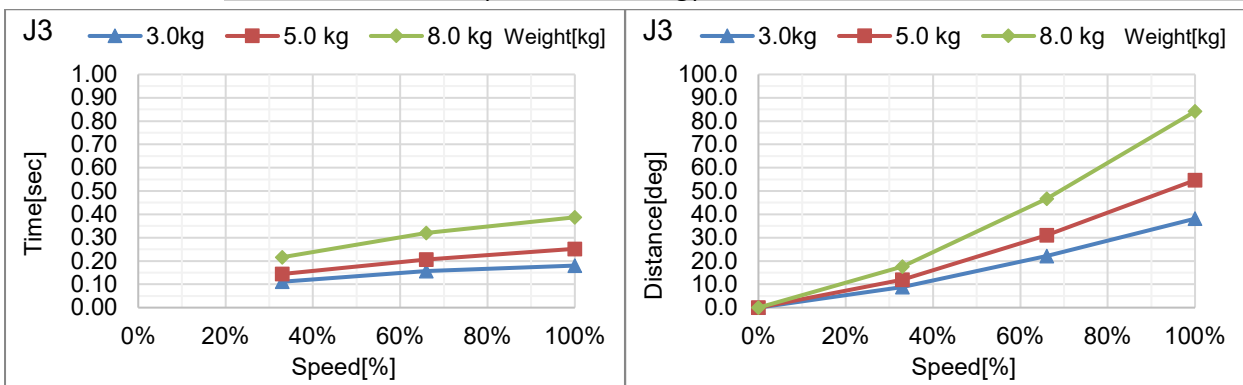

C8-A901***: J4 (Wall mounting)

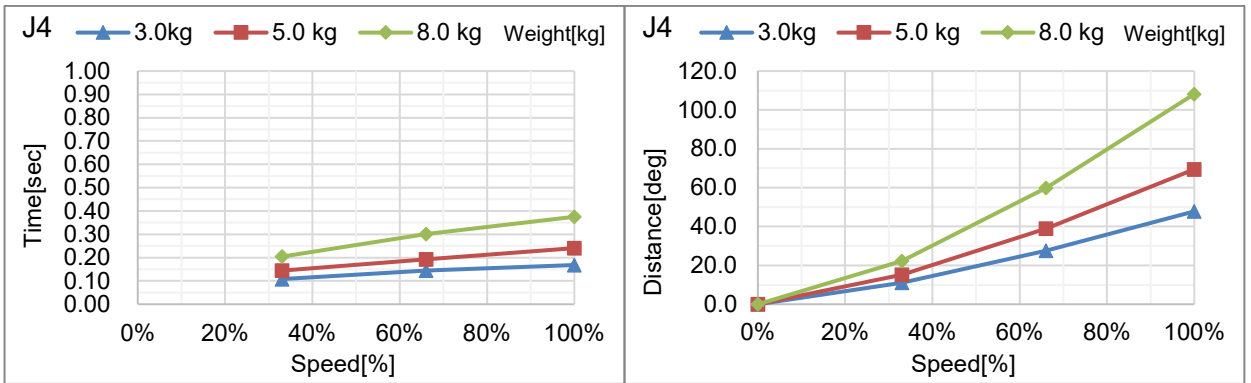

C8-A901***: J5 (Wall mounting)

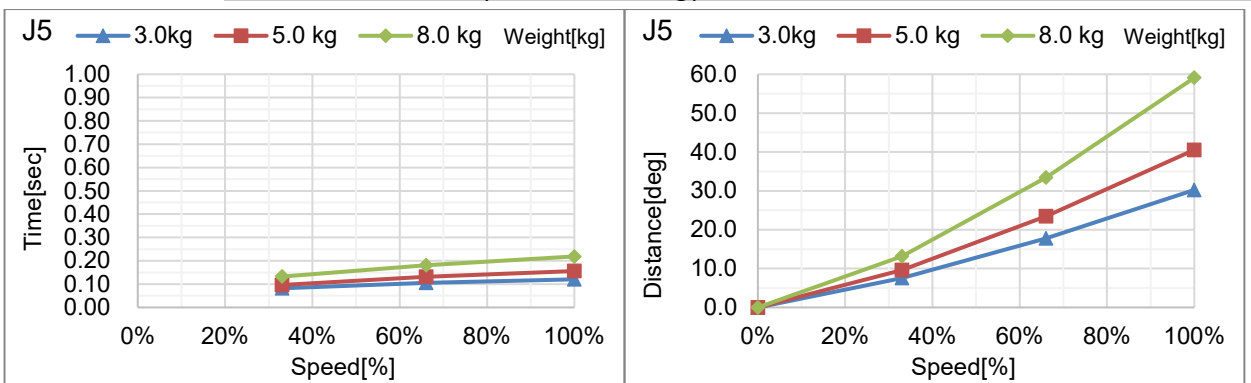

C8-A901***: J6 (Wall mounting)

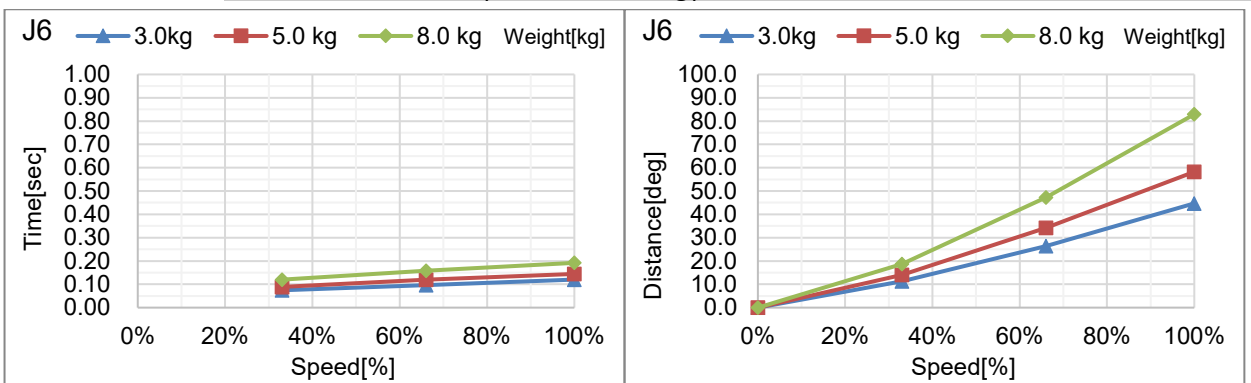

C8-A1401***: J1 (Table Top mounting, Ceiling mounting)

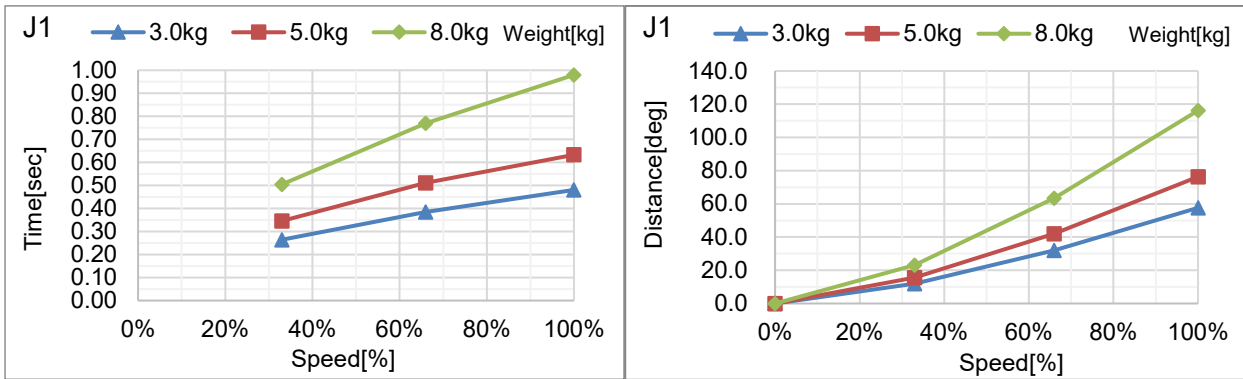

C8-A1401***: J2 (Table Top mounting, Ceiling mounting)

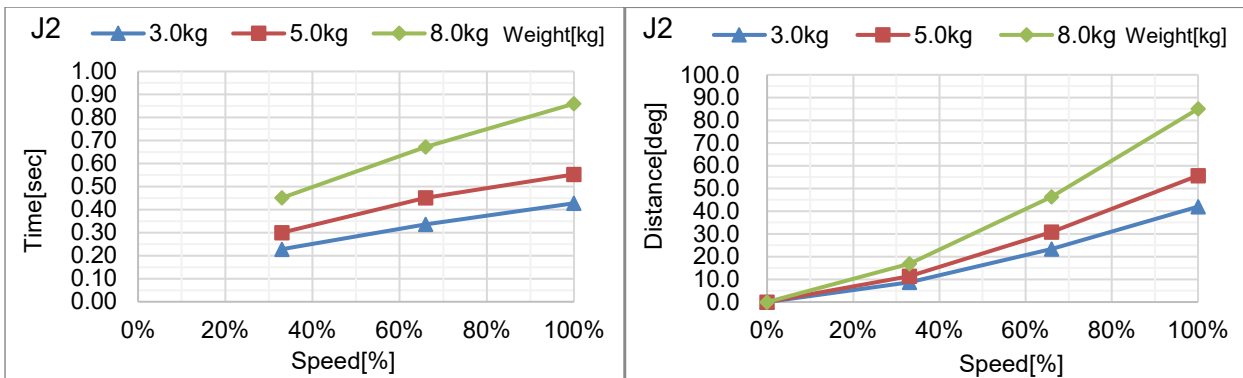

C8-A1401***: J3 (Table Top mounting, Ceiling mounting)

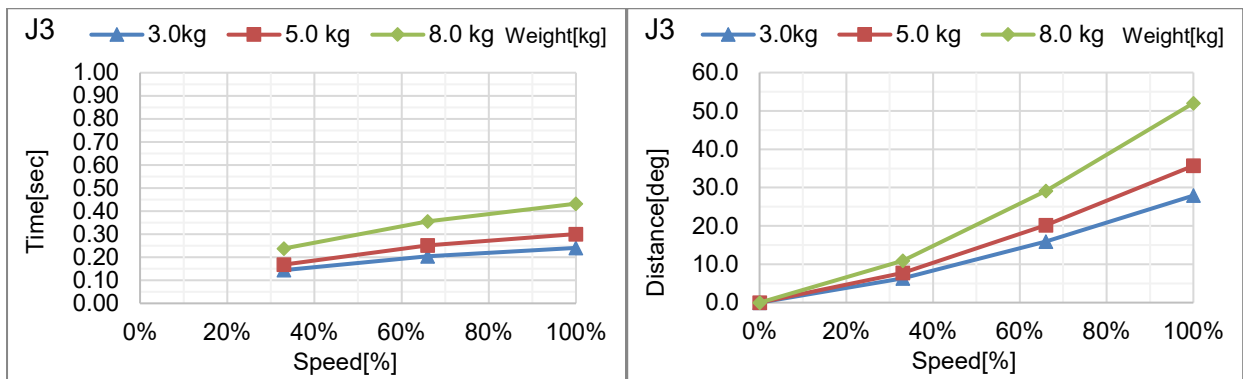

C8-A1401***: J4 (Table Top mounting, Ceiling mounting)

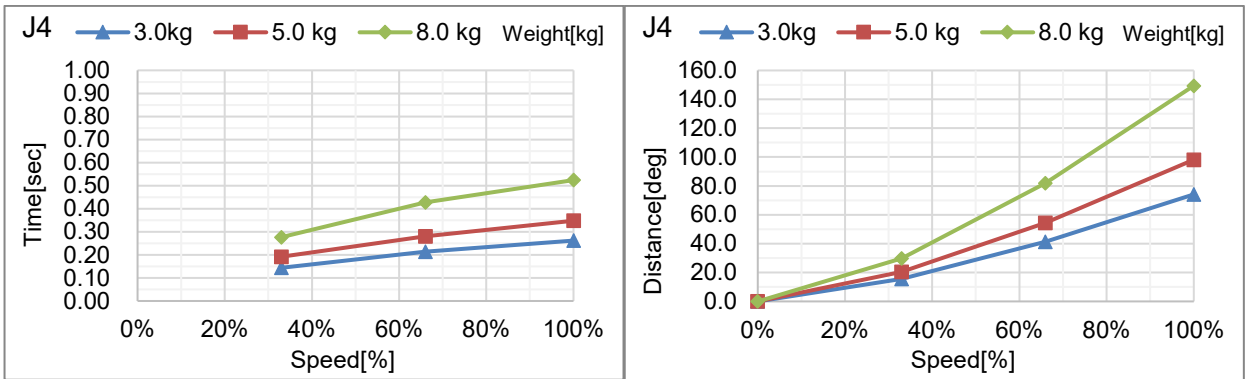

C8-A1401***: J5 (Table Top mounting, Ceiling mounting)

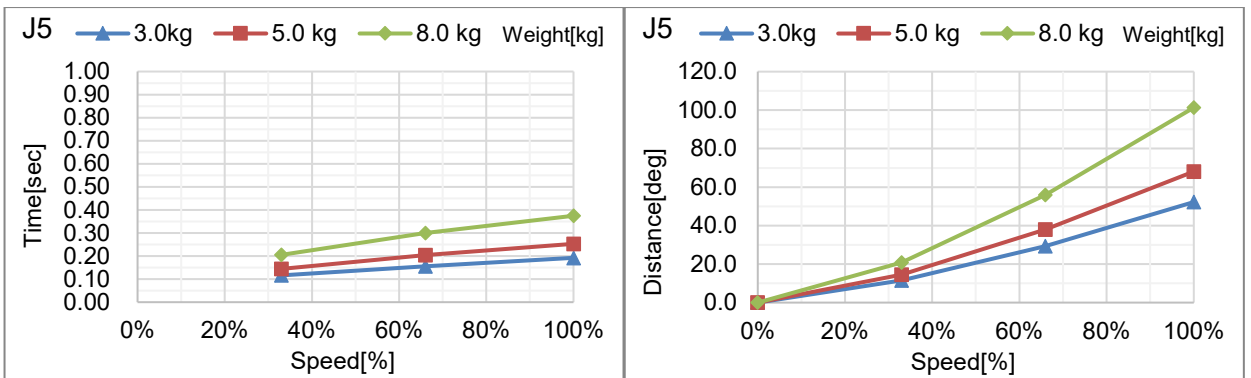

C8-A1401***: J6 (Table Top mounting, Ceiling mounting)

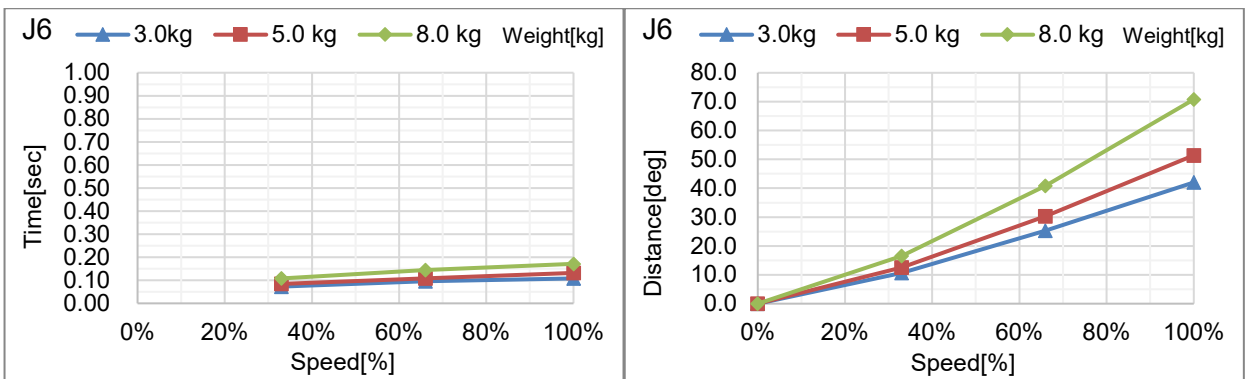

C8-A1401***: J1 (Wall mounting)

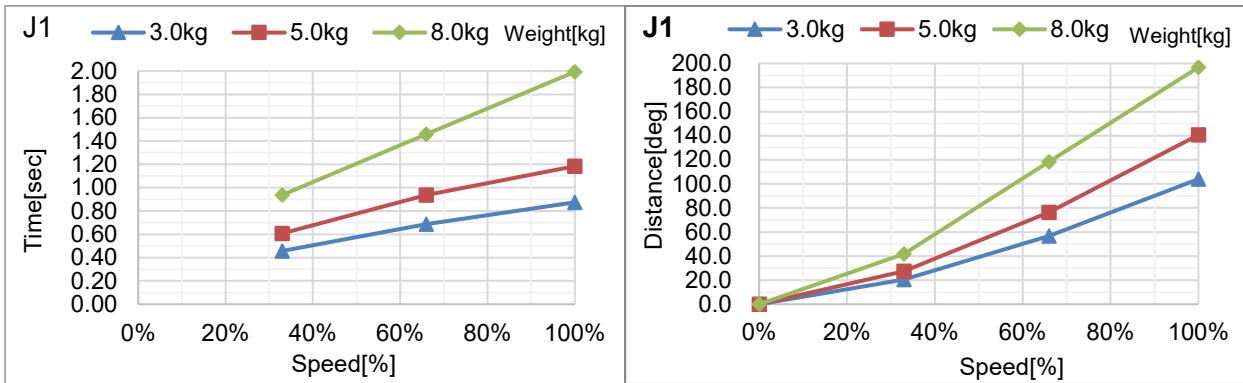

C8-A1401***: J2 (Wall mounting)

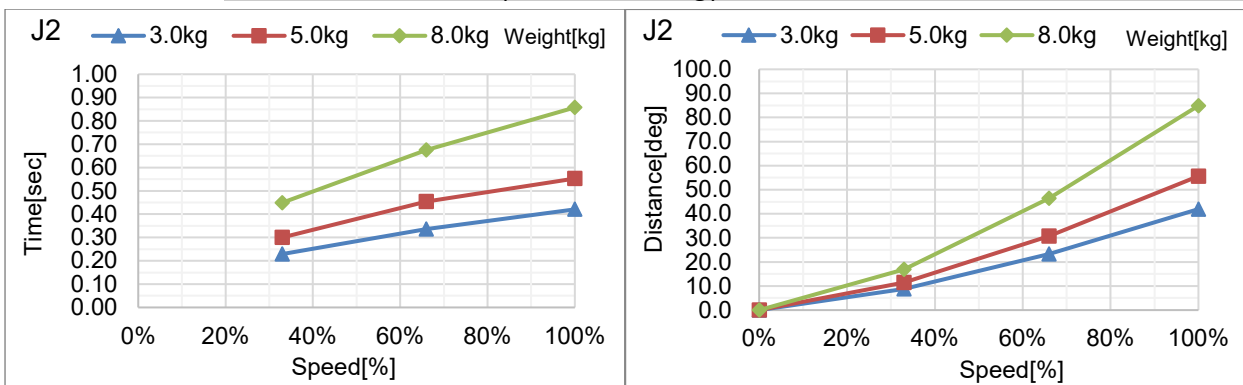

C8-A1401***: J3 (Wall mounting)

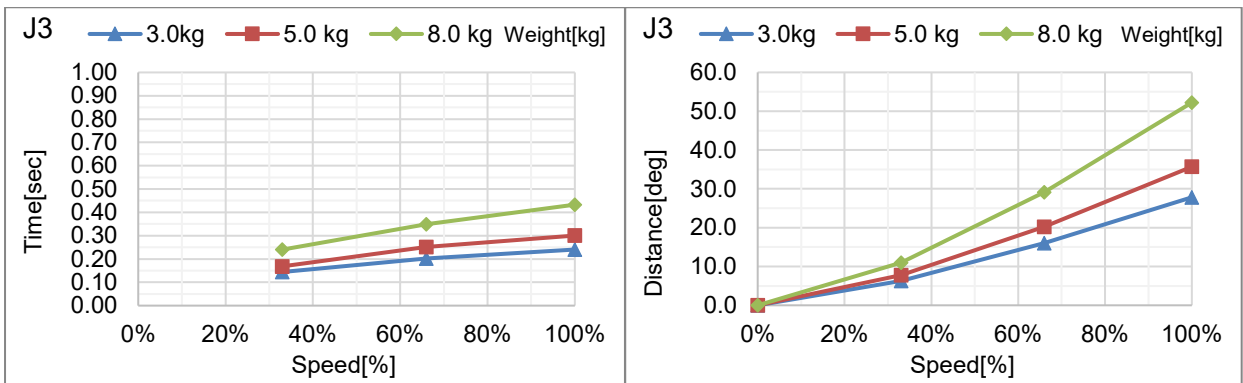

C8-A1401***: J4 (Wall mounting)

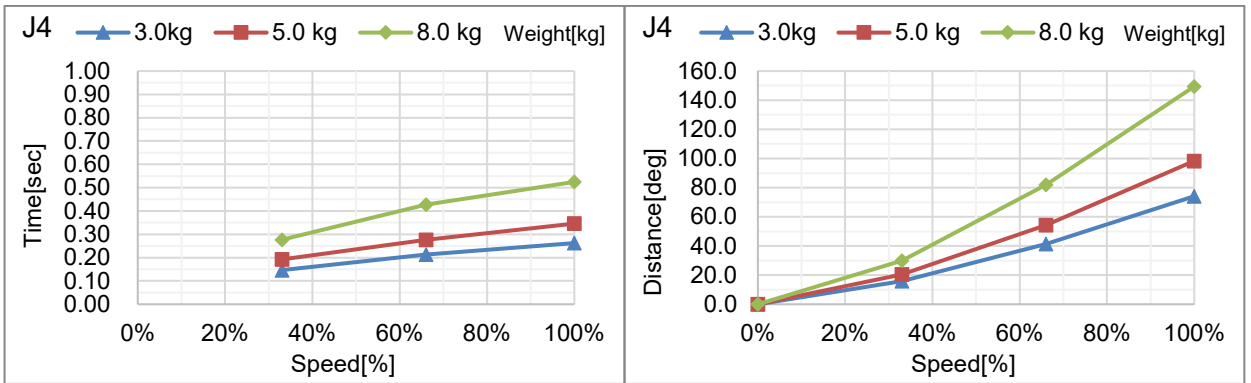

C8-A1401***: J5 (Wall mounting)

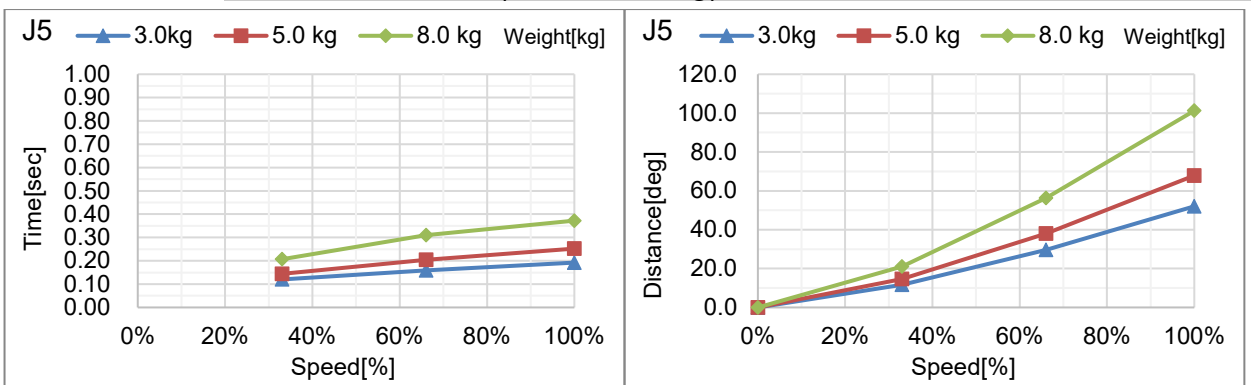

C8-A1401***: J6 (Wall mounting)

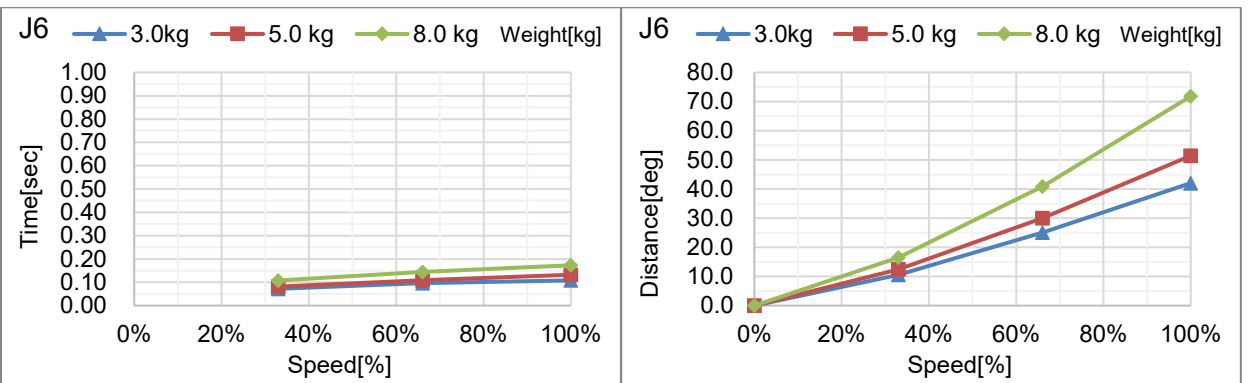

C12 Stopping time and Stopping distance When Safeguard Is Opened

C12-A1401**: J1 (Table Top mounting)

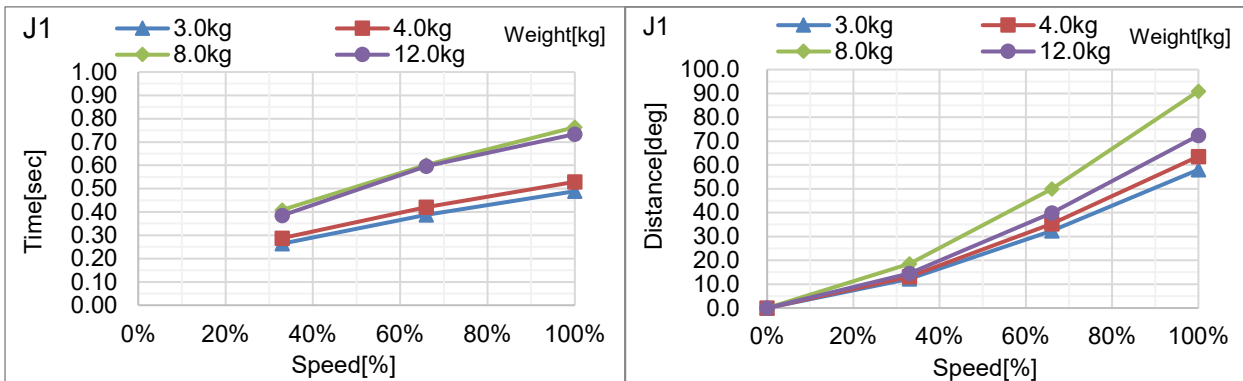

C12-A1401**: J2 (Table Top mounting)

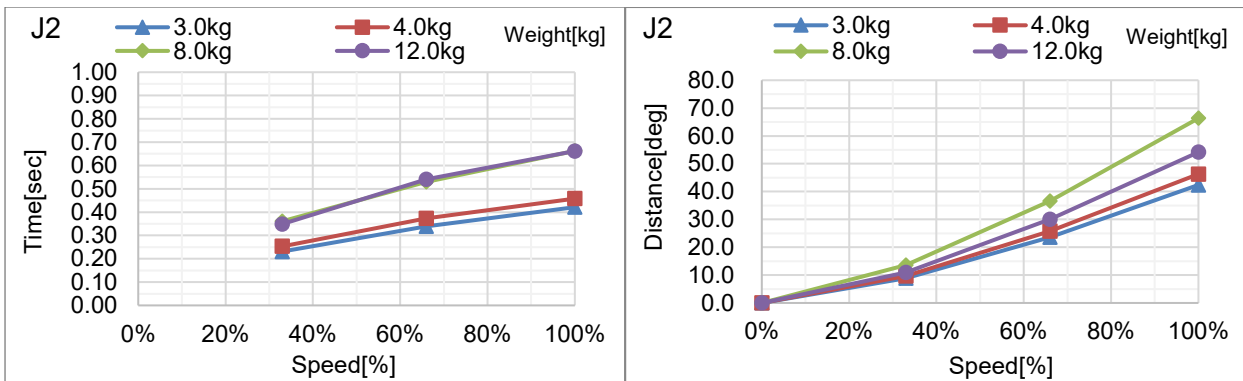

C12-A1401**: J3 (Table Top mounting)

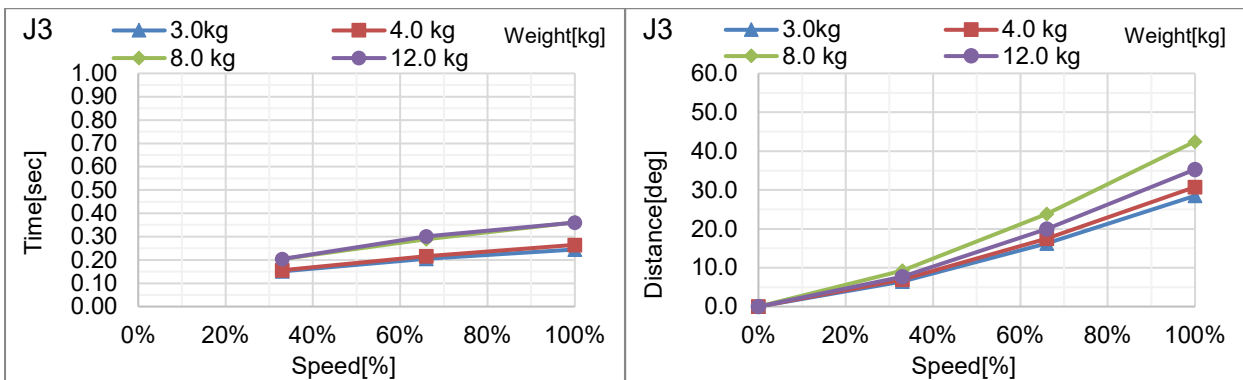

C12-A1401**: J4 (Table Top mounting)

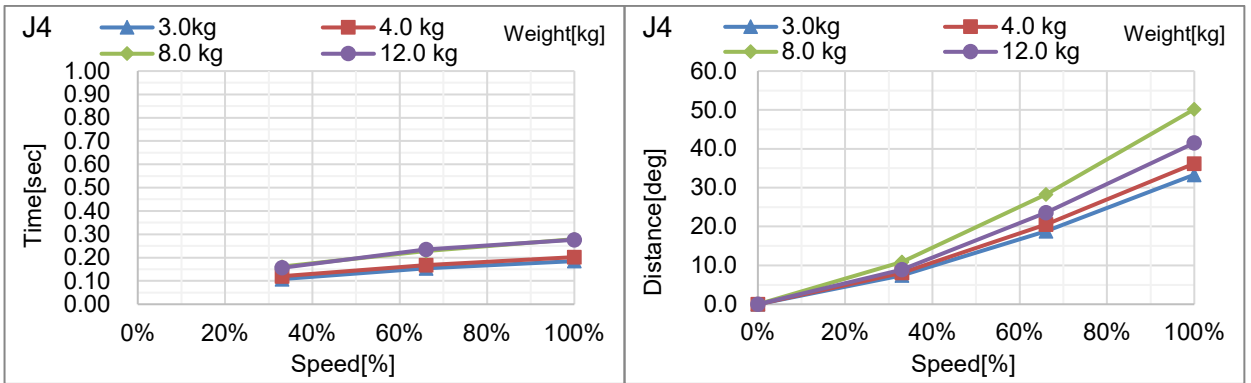

C12-A1401**: J5 (Table Top mounting)

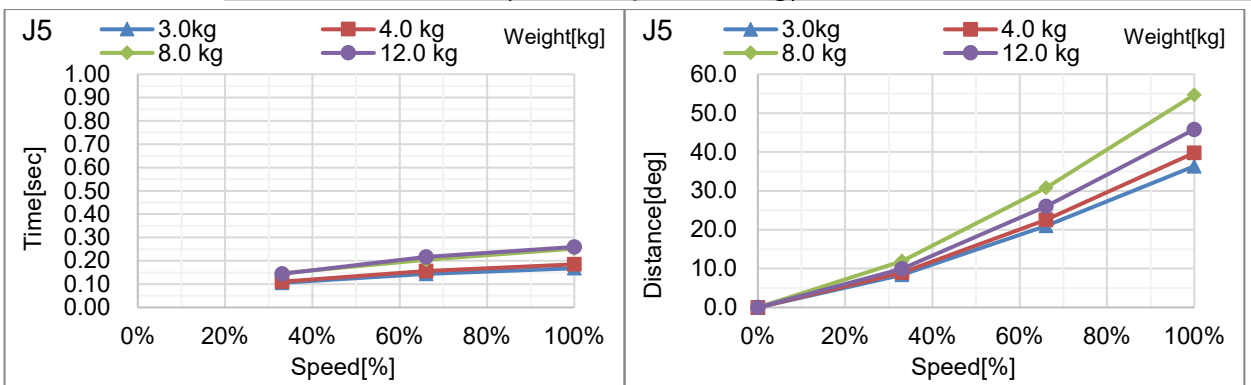

C12-A1401**: J6 (Table Top mounting)

