

EPSON

Robot Controller Option

Fieldbus I/O

Rev.1

ENM247C6607F

Original instructions

Epson RC+ 8.0

Robot Controller Option Fieldbus I/O Rev.1

Robot Controller Option

Fieldbus I/O

Rev.1

©Seiko Epson Corporation 2024

FOREWORD

This manual contains important information necessary to use the Robot Controller Option Fieldbus I/O properly and safely. This manual is intended for personnel who perform any operations using the pendant, such as teaching robot points.

Please thoroughly read this manual and other related manuals before and while using the equipment.

The robot system and its optional parts are shipped to our customers only after being subjected to the strictest quality controls, tests, and inspections to certify its compliance with our high performance standards. Please note that the basic performance of the product will not be exhibited if our robot system is used outside of the usage conditions and product specifications described in the manuals.

This manual describes possible dangers and consequences that we can foresee. Be sure to comply with safety precautions on this manual to use our robot system safely and correctly.

TRADEMARKS

Microsoft, Windows, Windows logo, Visual Basic, and Visual C++ are either registered trademarks or trademarks of Microsoft Corporation in the United States and/or other countries.

Pentium is a trademark of Intel Corporation in the United States.

DeviceNet™ is a registered trademark of ODVA (Open DeviceNet Vendor Association, Inc.).

EtherNet/IP™ is a trademark used under license by ODVA (Open DeviceNet Vendor Association, Inc.).

PROFIBUS and PROFINET are registered trademarks of PROFIBUS International.

CC-Link is a registered trademark of the CC-Link Partner Association.

EtherCAT® is registered trademark and patented technology, licensed by Beckhoff Automation GmbH, Germany.

EtherCAT® 

Other brand and product names are trademarks or registered trademarks of the respective holders.

TRADEMARK NOTATION IN THIS MANUAL

Microsoft® Windows® 10 operating system

Microsoft® Windows® 11 operating system

Throughout this manual, Windows 10 and Windows 11 refer to above respective operating systems. In some cases, Windows refers generically to Windows 10 and Windows 11.

NOTICE

No part of this manual may be copied or reproduced without authorization.

The contents of this manual are subject to change without notice.

Please notify us if you should find any errors in this manual or if you have any comments regarding its contents.

MANUFACTURER

SEIKO EPSON CORPORATION

CONTACT INFORMATION

For detailed contact information, see "SUPPLIER" of the manual below.

"Safety Manual"

Before Reading This Manual

This section describes what you should know before reading this manual.

Safety Precautions



The fieldbus I/O in this manual is a product that is connected to and used with EPSON Controllers used in industrial environments. Installation and transportation of robots and robotic equipment shall be performed by qualified personnel and should conform to all national and local codes.

Please carefully read this manual and other related manuals before installing the robot system or before connecting cables.

Keep this manual handy for easy access at all times. Please read the Safety chapter in User's Guide to understand safety requirements before installing the robot system.

Conventions

Important safety considerations are indicated throughout the manual by the following symbols. Be sure to read the descriptions shown with each symbol.

 WARNING	This symbol indicates that a danger of possible serious injury or death exists if the associated instructions are not followed properly.
 WARNING	This symbol indicates that a danger of possible harm to people caused by electric shock exists if the associated instructions are not followed properly.
 CAUTION	This symbol indicates that a danger of possible harm to people or physical damage to equipment and facilities exists if the associated instructions are not followed properly.

Security support for the network connection

The network connecting function (Ethernet) on our products assumes the use in the local network such as the factory LAN network. Do not connect to the external network such as the Internet.

In addition, please take security measure such as the antivirus software to block the virus from the network connection.

For T series, VT series Manipulator user only

T series and VT series Manipulators are controller integrated manipulators.

Read “Controller” and “Robot Controller” described in this manual as “T series Manipulator”
“VT series Manipulator”.

The Installation Folder for Epson RC+ 8.0

You can change the path for the installation folder for Epson RC+ 8.0 anywhere. This manual assumes that Epson RC+ 8.0 is installed in C:\EpsonRC80.

1. Introduction	1
1.1 Overview of Fieldbus I/O	1
1.2 DeviceNet	3
1.2.1 Overview of DeviceNet.....	3
1.2.2 Features of DeviceNet	3
1.2.3 General Specifications	5
1.3 PROFIBUS DP	6
1.3.1 Overview of PROFIBUS DP.....	6
1.3.2 Features of PROFIBUS DP	6
1.3.3 General Specifications	7
1.4 EtherNet/IP	8
1.4.1 Overview of EtherNet/IP	8
1.4.2 Features of EtherNet/IP	8
1.4.3 General Specifications	9
1.5 CC-Link.....	10
1.5.1 Overview of CC-Link.....	10
1.5.2 Features of CC-Link.....	10
1.5.3 General Specifications	11
1.6 PROFINET.....	12
1.6.1 Overview of PROFINET	12
1.6.2 Features of PROFINET.....	12
1.6.3 PROFINET Communication.....	13
1.7 EtherCAT	14
1.7.1 Overview of EtherCAT	14
1.7.2 Features of EtherCAT	14
1.7.3 General Specifications	15
2. Installation	16
2.1 DeviceNet.....	16
2.1.1 How to Setup a DeviceNet Network	16
2.1.2 DeviceNet Network Construction.....	17
2.1.3 Installing DeviceNet Master Board Manufactured by molex.....	25
2.1.4 Installing DeviceNet Board Manufactured by Hilscher	46
2.1.5 Installing DeviceNet Slave Board	71
2.1.6 Installing DeviceNet Slave Module	78
2.2 PROFIBUS-DP	84
2.2.1 How to Setup a PROFIBUS DP Network.....	84
2.2.2 PROFIBUS DP Network Construction.....	84
2.2.3 Installing PROFIBUS-DP Master Board Manufactured by molex	89

2.2.4	Installing PROFIBUS-DP Slave Board	112
2.2.5	Installing PROFIBUS-DP Slave Module	120
2.3	EtherNet/IP	128
2.3.1	How to Setup a EtherNet/IP Network	128
2.3.2	EtherNet/IP Network Construction.....	129
2.3.3	Installing EtherNet/IP Master Board Manufactured by molex	130
2.3.4	Installing EtherNet/IP Board Manufactured by Hilscher	153
2.3.5	Installing EtherNet/IP Slave Board	182
2.3.6	Installing EtherNet/IP Slave Module	189
2.4	CC-Link.....	197
2.4.1	Installing CC-Link Slave Board	197
2.4.2	Installing CC-Link Slave Module.....	212
2.5	PROFINET	224
2.5.1	Installing PROFINET Slave Board.....	224
2.5.2	Installing PROFINET Slave Module	231
2.6	EtherCAT	239
2.6.1	Installing EtherCAT Slave Board	239
2.6.2	Installing EtherCAT Slave Module.....	247
3.	Operation	257
3.1	SPEL+ Fieldbus I/O Commands	257
3.2	Outputs Off by Emergency Stop and Reset Instruction.....	257
3.3	Using FbusIO_SendMsg	258
3.4	Explicit Message Connection (for DeviceNet, EtherNet/IP).....	259
3.5	Setting Remote Control Input and Output.....	260
	Default Remote Control Input Setting for Fieldbus Master I/O	261
	Default Remote Control Output Setting for Fieldbus Master I/O	262
	Default Remote Control Input Setting for Fieldbus Slave I/O	264
	Default Remote Control Output Setting for Fieldbus Slave I/O	265
4.	Troubleshooting	267
4.1	DeviceNet Troubleshooting.....	267
	Exclusion	267
	Tools.....	267
4.1.1	Examining a Problem.....	268
4.1.2	Problems and Countermeasures.....	270
4.1.3	Procedures for Examining Possible Causes	288
4.2	PROFIBUS DP Troubleshooting.....	301
	Exclusion	301
	Tools.....	301

4.2.1 Examining a Problem	301
4.2.2 Problems and Countermeasures	303
4.2.3 Procedures for Examining Possible Causes	318
4.3 EtherNet/IP Troubleshooting	328
Exclusion	328
4.3.1 Examining a Problem	328
4.3.2 Problems and Countermeasures	330
4.3.3 Tests and Diagnostics	330
4.4 How to Disable Fast Startup in Windows	337
How to Disable Fast Startup	337
4.5 Disabling the PCI Express Native Setting	341
5. Maintenance Parts List	342

1. Introduction

1.1 Overview of Fieldbus I/O

1.1.1 Overview of Fieldbus

Fieldbus is a kind of network system by which signal communications between field devices operating in a factory (sensors, actuators, Robot Controllers, etc.) and Controllers (PLC or Robot Controllers) are carried out using serial communications. Compared to transmissions that use analog signals, a fieldbus has the following characteristics:

Access to signals from multiple devices and multiple data from a single device using one cable.

Precise signal transmission since there is no need for A/D and D/A conversion.

Several dozen (or even a hundred) devices can be connected to one fieldbus, lowering wiring costs while making signal relay boards unnecessary. You can save the cost of relay boards and recover the space where they are installed.

More flexible modification and expansion of a system because multiple devices are simply added to one fieldbus without additional wiring.

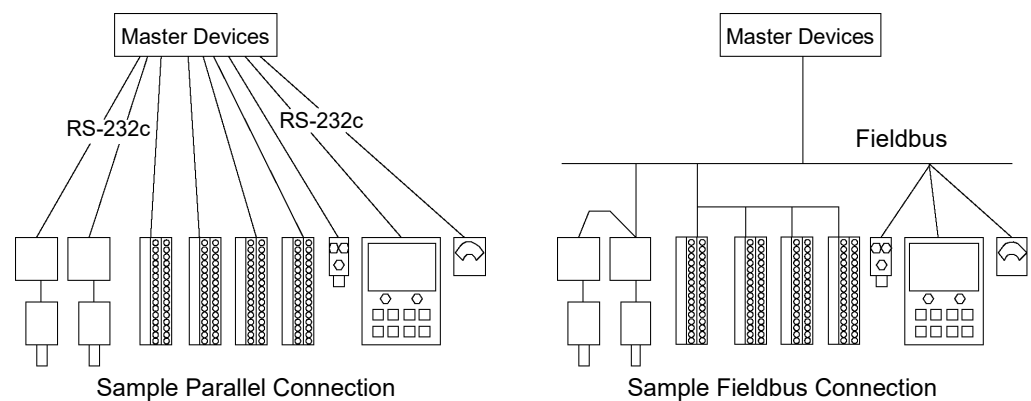

Slave devices can transmit self-diagnostic information.



1.1.2 Available Fieldbus Options

The Fieldbus I/O option supports the following fieldbus slave and fieldbus master functions.

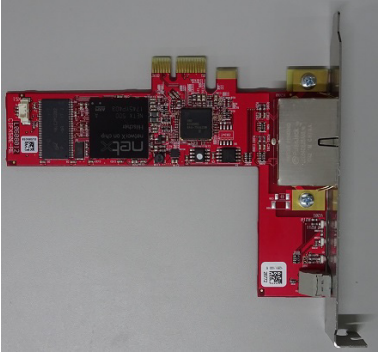
Interface	Slave		Master			
	Module	Board	Hilscher		molex	
Supported Model	RC800, T/VT	RC700, RC90	(RC800, T/VT, RC700, RC90)			
DeviceNet	✓	✓	✓	✓		✓
PROFIBUS-DP	✓	✓				✓
EtherNet/IP	✓	✓	✓	✓		✓
CC-Link	✓	✓				
PROFINET	✓	✓	✓	✓		
EtherCAT	✓	✓				

<p>Example of a fieldbus module</p> 	<p>Example of a master board (PCI-e)</p> 
<p>Example of a fieldbus board</p> 	<p>Example of master board (PCI)</p> 

NOTE Fieldbus master supports following OS:



	molex	Hilscher
Windows 10 Pro	Supported	Supported
Windows 11 Pro	Not supported	Supported

1.1.3 Examples Showing the Use of Fieldbus

When using slave function:

By attaching a fieldbus slave board or fieldbus slave module to a robot controller, you can add fieldbus slave functionality.

One fieldbus slave board can be installed in the controller.

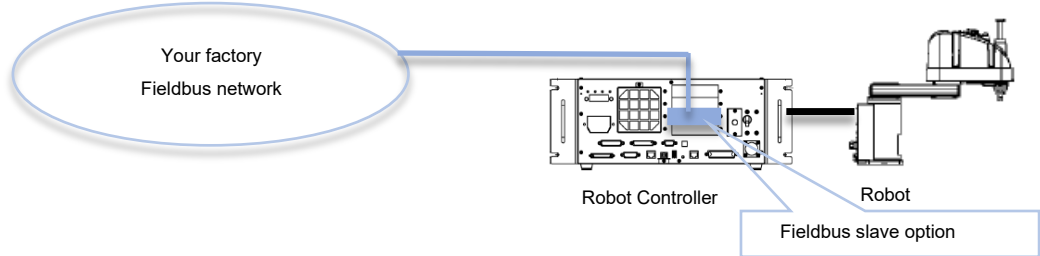

When using master function:

By installing a fieldbus master board in a PC (control PC) on which Epson RC+ 8.0 is installed, you can add fieldbus master functionality.

You can install one fieldbus master board per PC.

The fieldbus master I/O can be controlled from the robot controller.

To use the fieldbus master I/O, the fieldbus master option of the Epson RC+ software options key must be enabled.

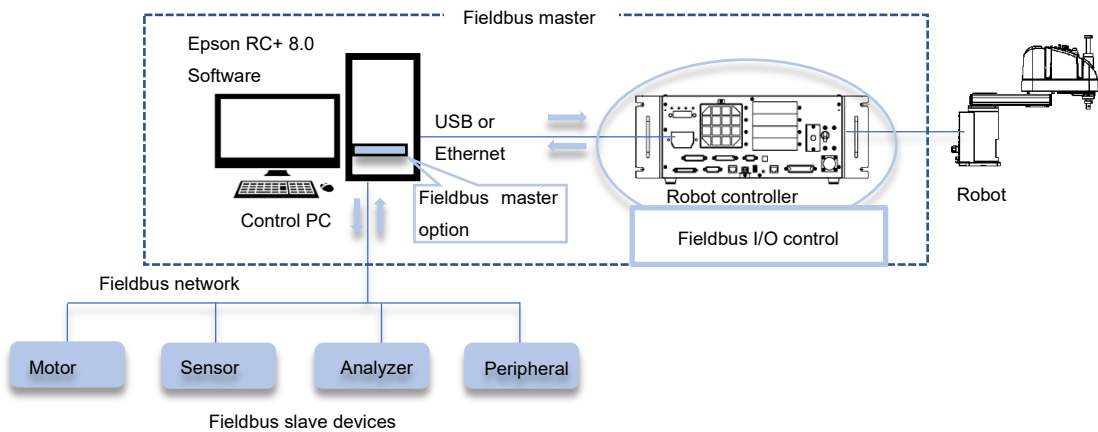

When using slave and master function at the same time:

Fieldbus master boards and fieldbus slave boards or fieldbus slave modules can be used in combination simultaneously regardless of their types.

For example, you can use a fieldbus master with DeviceNet in combination with a fieldbus slave with EtherNet/IP.

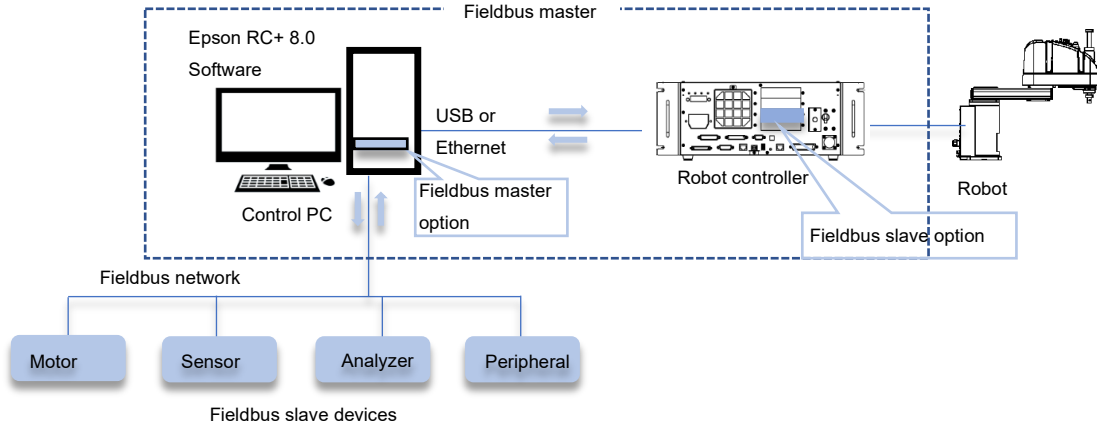

1.2 DeviceNet

1.2.1 Overview of DeviceNet

DeviceNet is a fieldbus network that provides easy interconnection between control devices (PLC, PC, sensor, actuator, etc.).

DeviceNet was developed by Allen-Bradley as an open communication standard to connect various field devices (sensor, actuator, Robot Controller, etc.). Because of the open communication standard, DeviceNet users can easily construct a multi-vendor system with various devices developed around the world.

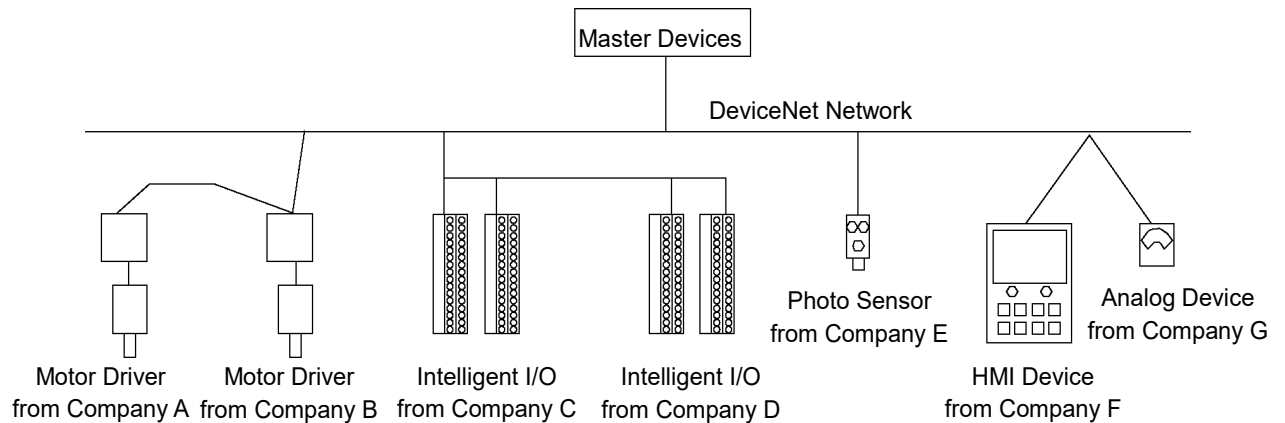

1.2.2 Features of DeviceNet

Reduced Wiring

Compared with parallel wiring, DeviceNet employs a dedicated 5-wire cable (signal wires and power wires) which substantially reduces the number of necessary wires, wiring time and cost.

Detachable communication connectors provide you with simple wiring between nodes and easy network separation or reconstruction.

Specified environment-resistance cables allow you to construct an environment-resistant system at low cost.

Open Standard (Multi-vendor)

Due to an open communication standard, various devices from many manufacturers are available. Standardized communication connectors provide you with easy network reconstruction.

Maintenance spare parts stored on site (factory, etc.) can be reduced because different manufacturers' devices can be used in case of a breakdown. Similar products are available around the world due to a global standard DeviceNet.

Communication Types

There are two types of messaging connections: I/O messaging connection and Explicit messaging connection. I/O messaging connection includes the four methods explained below:

- Polling** : First, a master device sends output data to a slave device and then the slave device responds. Data is normally exchanged in every communication cycle. The communication frequency can be changed by setting. This connection type is the most often used.

Strobe : First, a master device requests slave devices to send data with multicast messages, and then, each slave device responds individually. Data from many sensors on the system can be effectively gathered. When the master does not receive responses from all requested slave devices, a timeout error occurs.

Change Of State: A device sends data whenever it changes. Signals for device diagnosis are sent regularly in the background. This connection type is useful for remedying DeviceNet communication traffic.

Cyclic : A slave device transfers data regularly according to its internal timer. This connection type is typically used for communicating with a temperature controller. The data transfer frequency is defined by master configuration.



For Change of State and Cyclic, the ACK which verifies communication completion can be disabled by setting. However, never disable the ACK since communication errors cannot be detected.

1.2.3 General Specifications

DeviceNet Communication Specifications

Item	Specification			
Supported Connection	- I/O messaging connection (Polling, Strove, Cyclic, Change of State) - Explicit messaging connection All connections are conformed to DeviceNet communication protocol.			
Baud Rates	125 kbps, 250 kbps, 500 kbps			
Transfer Distance	Baud Rates	Max. Network Length	Drop Length	Total Drop Line Length
	500 k (bps)	100 m	6 m or under	39 m or under
	250 k (bps)	250 m *	6 m or under	78 m or under
	125 k (bps)	500 m *	6 m or under	156 m or under
Maximum Nodes	64 (including master unit)			
Data Length / Frame	8 bytes (data can be divided and transferred.)			
Bus Access	CSMA/NBA			
Error Detection	CRC error / Duplicate node address check			
Cable	5-wire cable dedicated to DeviceNet (2 wires for signal, 2 wires for power supply, 1 shield wire)			
Communications Power Supply Voltage	24 V DC (supplied from a connector)			

* When thin cable is used for trunk line, the maximum network length is 100 m.

1.3 PROFIBUS DP

1.3.1 Overview of PROFIBUS DP

PROFIBUS DP is a fieldbus network that provides easy interconnection between control devices (PLC, PC, sensor, actuator, etc.).

PROFIBUS DP was co-developed by Siemens, Bosch, and ABB as an open communication standard to connect various field devices (sensor, actuator, Robot Controller, etc.). Because of the open communication standard, PROFIBUS DP can easily construct multi-vendor system with various devices developed around the world.

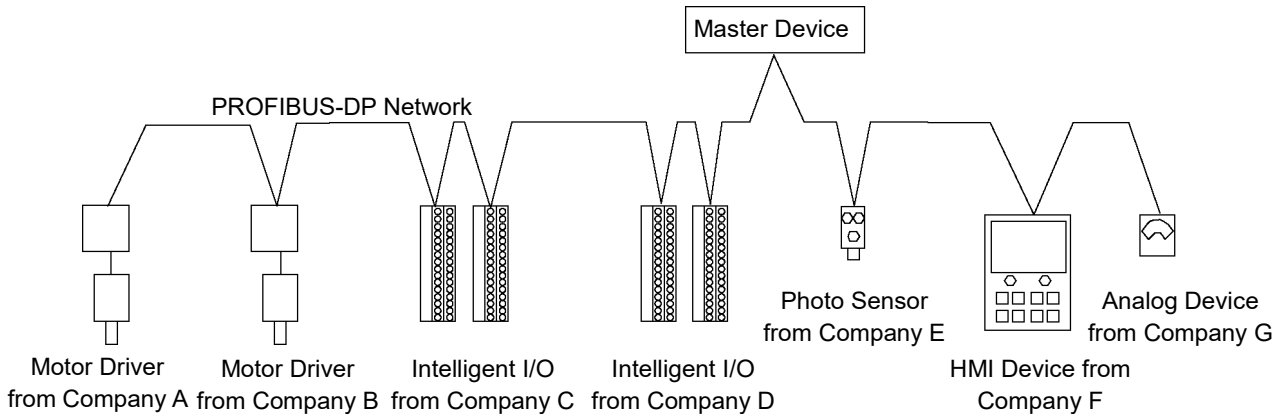

1.3.2 Features of PROFIBUS DP

Reduced Wiring

Compared with a parallel wiring, PROFIBUS DP employing dedicated 2-wire cable substantially reduces the number of necessary wires, wiring time and cost.

Detachable communication connector provides you a simple wiring between devices (stations) and an easy network separation or reconstruction.

Fast Communication

PROFIBUS DP communication speed can be set up to 12Mbps. This is faster than DeviceNet, another communication standard supported by the fieldbus I/O.

Open Standard (Multi-vendor)

Due to an open communication standard, various devices from many manufacturers are available. Standardized communication connectors allow you to reconstruct your network easily.

Maintenance parts stored on site (factory, etc.) can be reduced because different manufacturers' devices can be used in case of a breakdown. Similar products are available around the world due to a global standard PROFIBUS DP.

1.3.3 General Specifications

PROFIBUS DP Communication Specifications

Item	Specification	
Communication Method	Hybrid (token passing procedure and master-slave communication)	
Baud Rates	9.6 kbps, 19.2 kbps, 93.75 kbps, 187.5 kbps, 500 kbps, 1500 kbps, 3 Mbps, 6 Mbps, and 12 Mbps.	
Transfer Distance	Baud Rates	Cable Length
	12 Mbps	100 m
	6 Mbps	100 m
	3 Mbps	100 m
	1500 kbps	200 m
	500 kbps	400 m
	187.5 kbps	1000 m
	93.75 kbps	1200 m
19.2 kbps	1200 m	
9.6 kbps	1200 m	
Maximum Stations	126 (including master unit and repeater)	
Data Length / Frame	244 bytes	
Cable	2-wire cable dedicated to PROFIBUS (2 wires for signal)	

1.4 EtherNet/IP

1.4.1 Overview of EtherNet/IP

EtherNet/IP is a fieldbus network that provides easy interconnection between control devices (PLC, PC, sensor, actuator, etc.).

EtherNet/IP was developed by Allen-Bradley as an open communication standard to connect various field devices (sensor, actuator, Robot Controller, etc.). Because of the open communication standard, EtherNet/IP users can easily construct a multi-vendor system with various devices developed around the world.

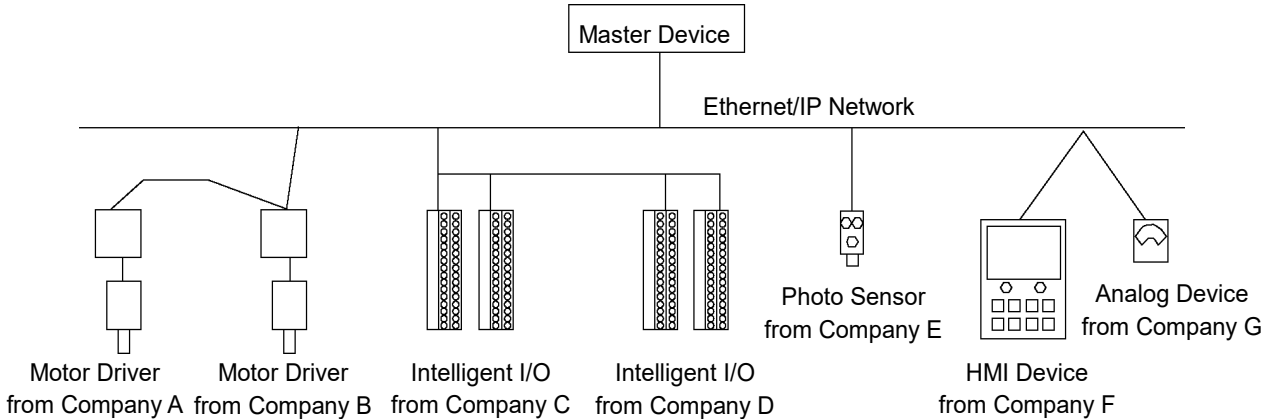

1.4.2 Features of EtherNet/IP

Reduced Wiring

Compared with parallel wiring, EtherNet/IP employs a standard Ethernet cable which substantially reduces the number of necessary wires, wiring time and cost.

Detachable communication connectors provide you with simple wiring between nodes and easy network separation or reconstruction.

Specified environment-resistance cables allow you to construct an environment-resistant system at low cost.

NOTE

You can use the general Ethernet hub or Ethernet switch for EtherNet/IP. However, be sure to use a product complying with the industrial standards or a noise-resistant Ethernet cable (STP cable). If you use an office use product or UTP cable, it may causes communication errors and may not offer the proper performance.

Open Standard (Multi-vendor)

Due to an open communication standard, various devices from many manufacturers are available. Standardized communication connectors provide you with easy network construction.

Maintenance spare parts stored on site (factory, etc.) can be reduced because different manufacturers' devices can be used in case of a breakdown. Similar products are available around the world due to a global standard EtherNet/IP.

Connection Types

There are two types of messaging connections: I/O messaging connection and Explicit messaging connection. I/O messaging connection includes the two methods explained below:

Change Of State: A device sends data whenever it changes. Signals for device diagnosis are sent regularly in the background. This connection type is useful for remedying EtherNet/IP communication traffic.

Cyclic : A slave device transfers data regularly according to its internal timer. This connection type is typically used for communicating with a temperature Controller. The data transfer frequency is defined by master configuration.

NOTE

For Change of State and Cyclic, the ACK which verifies communication completion can be disabled by setting. However, never disable the ACK since communication errors cannot be detected.

1.4.3 General Specifications

EtherNet/IP Communication Specifications

Item	Specification
Supported Connection	- I/O messaging connection (Cyclic, Change of State) - Explicit messaging connection All connections are conformed to EtherNet/IP communication protocol.
Baud Rates	100 Mbps, 10 Mbps
Maximum Nodes	128 (including master unit)
Data Length / Frame	244 bytes
Access Control Type	CSMA/CD
Cable	Universal Ethernet cable

1.5 CC-Link

1.5.1 Overview of CC-Link

CC-Link is a fieldbus network that provides easy interconnection between control devices (PLC, PC, sensor, actuator, etc.).

CC-Link was developed as an open communication standard to connect various field devices (sensor, actuator, Robot Controller, etc.). Because of the open communication standard, CC-Link can easily construct multi-vendor system with various devices developed around the world.

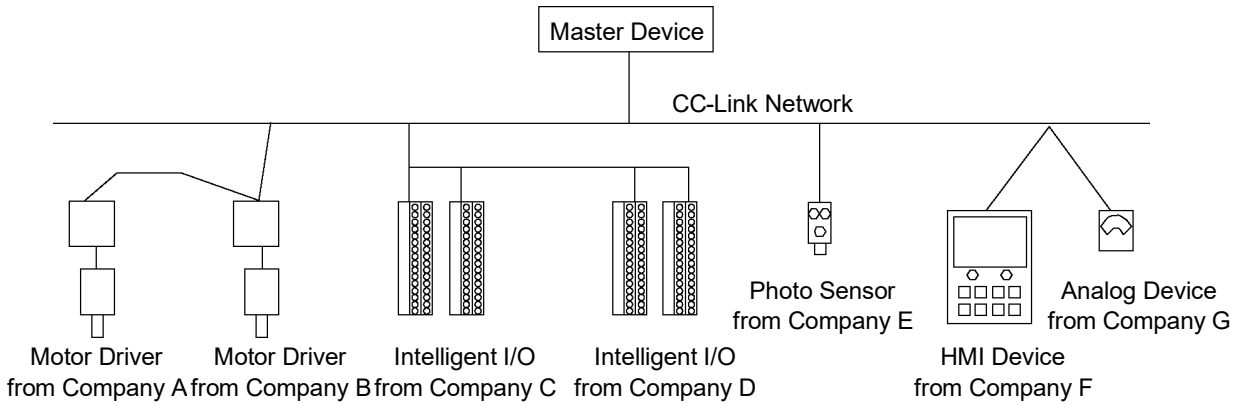

1.5.2 Features of CC-Link

Reduced Wiring

Compared with a parallel wiring, CC-Link employs triplex shielded twisted pair cable which substantially reduces the number of necessary wires, wiring time and cost.

Detachable communication connector provides you a simple wiring between devices (nodes) and an easy network separation or reconstruction.

Fast Communication

From 156k bps to 10M bps is available. The speed of 10M bps is the fastest field network next to PROFIBUS-DP.

Transmission Control

The communication network includes master stations and slave stations. Normally, PLC becomes a master station. Up to 64 slave stations can be connected to a master station. The slave station includes remote device stations (handling the bit data and word data), remote I/O stations (handling the bit data), and others. The master station stores the information such as the type and address of slave stations in the network and controls the whole network.

Open Standard (Multi-vendor)

Due to an open communication standard, various devices from many manufactures are available. Standardized communication connectors allow you to reconstruct your network easily.

Maintenance parts stored on site (such as factory) can be reduced because different manufacturers' devices can be used in case of a breakdown. Similar products are available around the world due to a global standard PROFIBUS DP.

1.5.3 General Specifications

CC-Link Communication Specifications (Ver.1.10 / Ver2.00)

Item	Specification
Baud Rates (bps)	156 k, 625 k, 2.5 M, 5 M, 10 M
Connection Method	Broadcast polling
Synchronization Method	Frame synchronization
Encoding Method	NRZI
Transmission Channel Type	Bus (EIA RS485 compliant)
Transmission Format	HDLC compliant
Maximum Number of Devices	64 units
Slave Station Number	1 to 64
Connection Cable	CC-Link Ver1.10 cable (3 core twist cable with a shield)

1.6 PROFINET

1.6.1 Overview of PROFINET

PROFINET is a fieldbus network that uses industrial Ethernet.

PROFINET was developed as an open communication standard to connect various field devices (sensor, actuator, Robot Controller, etc.). Because of the open communication standard, PROFIBUS DP can easily construct multi-vendor system with various devices developed around the world.

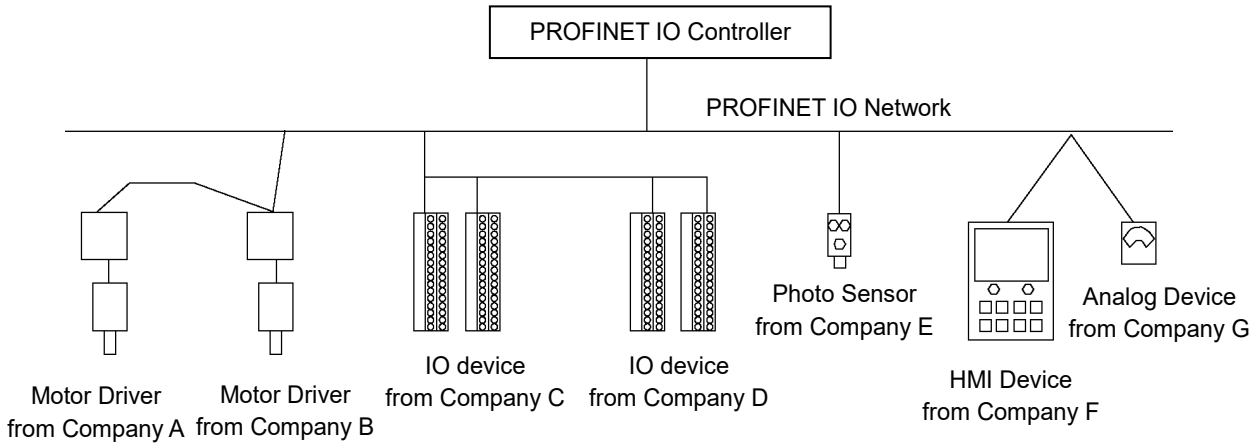

1.6.2 Features of PROFINET

Everything on one cable

With its integrated, Ethernet-based communication, PROFINET satisfies a wide range of requirements, from extremely fast I/O data transmission to parameter monitoring and configurations of equipment.

Flexible network topology

PROFINET is 100% Ethernet compatible according to IEEE standards and adapts to the environment of existing plant due to its flexible line, ring, and star structures.

Standardization

PROFINET is defined by international standards “IEC 61158” and “IEC 61784”.

Concept of PROFINET has been developed based on standard Ethernet of IEEE802 through a joint effort with its users. Functionality has been added to cover the area that standard Ethernet cannot satisfy.

1.6.3 PROFINET Communication

PROFINET is designed to support all applications in a plant versatily with one bus.

Therefore, PROFINET has three different performance levels as described below.

For this option, “2: RT (Real-time)” communication is supported.

1: NRT (Non Real-time)

This communication is based on TCP/IP.

This is used for applications where real-time communication is not required, such as inter-unit communication and parameter communication.

2: RT (Real-time)

By adding a software protocol to the standard Ethernet hardware, this method actualizes real-time communication with approximately 10 ms intervals.

In particular, by defining a priority in VLAN tag (IEEE803.1Q) in Ethernet frame, RT frame is processed with a higher priority to non-real-time data (NRT, TCP/IP, etc.)

RT can offer almost the same performance as the existing fieldbus.

3: IRT (Isochronous Real-time)

Isochronous real-time communication (IRT) guarantees that communication is surely executed within an arbitral communication time (Deterministic) at a higher level than Real-time communication (RT).

This enables a clock rate of < 1 ms and a jitter precision of < 1 μ s.

IRT is used for applications where a strict real-time performance is required, such as motion control. As a communication hardware, switch-function-embedded special ASIC is used. This method guarantees the real-time performance by dividing the communication band on Ethernet.

1.7 EtherCAT

1.7.1 Overview of EtherCAT

EtherCAT (Ethernet for Control Automation Technology) is a fieldbus network that provides easy interconnection between control devices (PLC, PC, sensor, actuator, etc.).

EtherCAT was developed as an open communication standard to connect various field devices (sensor, actuator, Robot Controller, etc.). Because of the open communication standard, EtherCAT can easily construct multi-vendor system with various devices developed around the world.

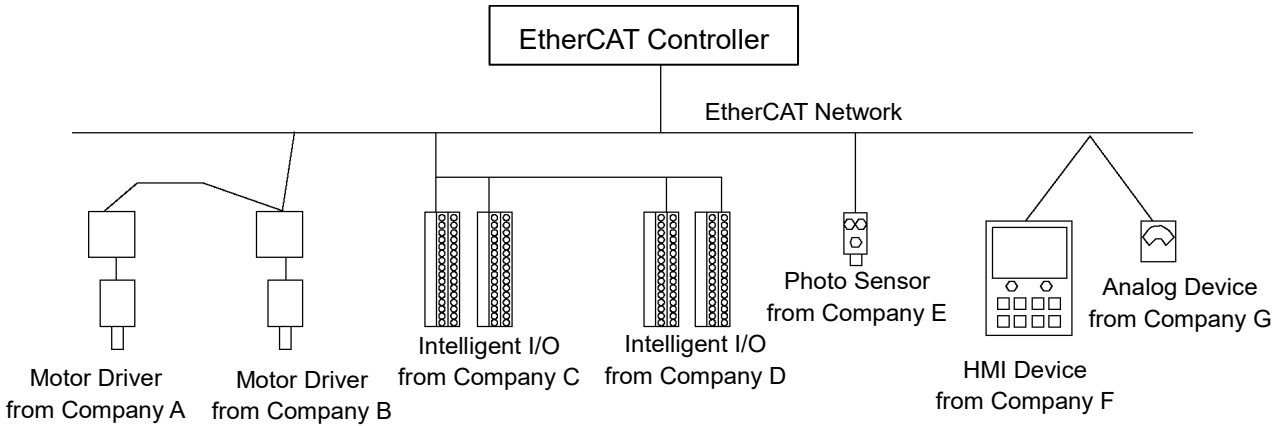

1.7.2 Features of EtherCAT

Protocol

EtherCAT uses only standard frames which comply with IEEE802.3. Therefore, EtherCAT frames are available for transmission from a general Ethernet Controller (master) and are able to use standard tools (such as a monitoring tool).

EtherCAT protocol is optimized for the control data. It is directly stored in the Ethernet frame and transmitted.

Reduced Wiring

Compared with parallel wiring, EtherCAT employs a standard Ethernet cable which substantially reduces the number of necessary wires, wiring time and cost.

Detachable communication connectors provide you with simple wiring between nodes and easy network separation or reconstruction.

Specified environment-resistance cables allow you to construct an environment-resistant system at low cost.

Network topology of EtherCAT is usually line, but other topologies such as star, daisy chain, or ring can also be used.



You can use the general network switch hub for EtherCAT. However, be sure to use a product complying with the industrial standards or a noise-resistant Ethernet cable (STP cable). If you use an office use product or UTP cable, it may causes communication errors and may not offer the proper performance.

Open Standard (Multi-vendor)

Due to an open communication standard, various devices from many manufacturers are available. Standardized communication connectors provide you with easy network construction.

Maintenance spare parts stored on site (factory, etc.) can be reduced because different manufacturers' devices can be used in case of a breakdown. Similar products are available around the world due to a global standard EtherNet/IP.

Network Topology

Network topologies such as line, tree, star, and ring are supported and can be used in combinations.

Line topology, which is most commonly used for fieldbus, especially has no factor which reduces network performance since it does not require a network switch or hub. Therefore, the fastest and most reliable network construction is possible.

1.7.3 General Specifications

EtherCAT Communication Specifications

Item	Specification
Baud Rates (bps)	100 M (Full duplex)
Network Topology	Line, Tree, Star, Ring
Communication Range	Distance between nodes: within 100 m
Maximum Nodes	65535
Cable	STP cable Category 5

2. Installation

This chapter describes procedures for installing the network.

DeviceNet
 PROFIBUS DP
 EtherNet/IP
 CC-Link
 PROFINET
 EtherCAT

Refer to the sections according to the type of network you are installing.

2.1 DeviceNet



- Make sure that the power is turned OFF before installing/removing any boards or modules or connecting/disconnecting any cables. Installing/removing any boards or connecting/disconnecting any cables with the power ON is extremely hazardous and may result in electric shock and/or malfunction of equipment.



- Pay attention to the followings in order to prevent the DeviceNet connector from coming off.
 1. Use the connectors attached to the board.
 2. Insert the connectors all the way seated.
 3. Fix the cables at proper positions in order not to put a load on the connectors.

2.1.1 How to Setup a DeviceNet Network

The following is a basic procedure for setting up a DeviceNet network:

1. Choose node layout and pathway on your network.
 For details, refer to *2.1.2 DeviceNet Network Construction*.
2. Choose power supply method for communication.
 For details, refer to *2.1.2 DeviceNet Network Construction*.
3. Choose baud rate.
 Choose the baud rate based on the network length. Select the fastest baud allowed for the length. Increasing network load due to slow baud rate may cause trouble including communication failure.
4. Lay cables.
 For details, refer to *2.1.2 DeviceNet Network Construction*.
5. Configure the nodes.
 For details, refer to respective manuals of your desired nodes.
6. Turn ON the communications power supply and nodes.
 Turn ON the communications power supply. After that (or simultaneously), turn ON the nodes to supply power. When the power to the nodes is supplied earlier than the power to the communication power supply, communication with the nodes may fail.

7. Install the DeviceNet board manufactured in your Controller.
Refer to the following for the fieldbus type you have.
 - When installing a DeviceNet master board manufactured by molex:
"2.1.3 Installing a DeviceNet Master Board Manufactured by molex"
 - When installing a DeviceNet board manufactured by Hilscher:
"2.1.4 Installing a DeviceNet Board Manufactured by Hilscher"
 - When installing a DeviceNet slave board:
"2.1.5 Installing a DeviceNet Slave Board"
 - When installing a DeviceNet slave module:
"2.1.6 Installing a DeviceNet Slave Module"
8. Operate the DeviceNet network.

2.1.2 DeviceNet Network Construction

Network Configuration

DeviceNet network is configured as shown in the following figure.

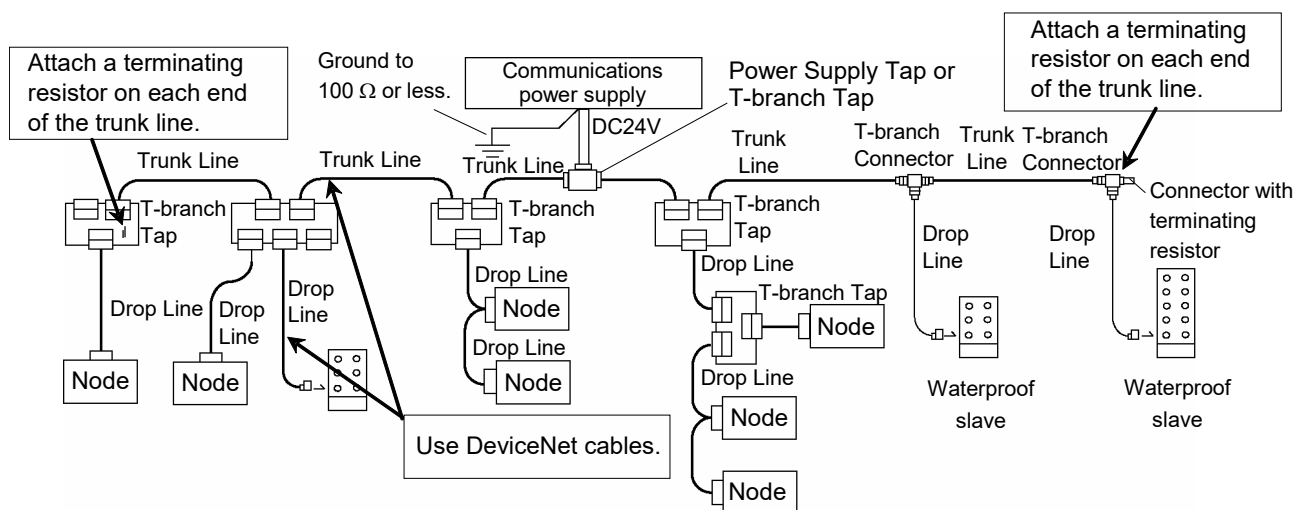

Node

There are two types of nodes: master and slave. The master controls a network and gathers data from its slaves. The slaves, including external I/O and other devices, output data in response to the master's output order and informs the master of its input status.

You can install masters anywhere in the network. You can connect up to 64 nodes (including the server) in the network.

Trunk Line and Drop Line

Trunk line is a backbone cable of DeviceNet network with terminating resistors on the both ends.

Drop line is a branch of the trunk line.

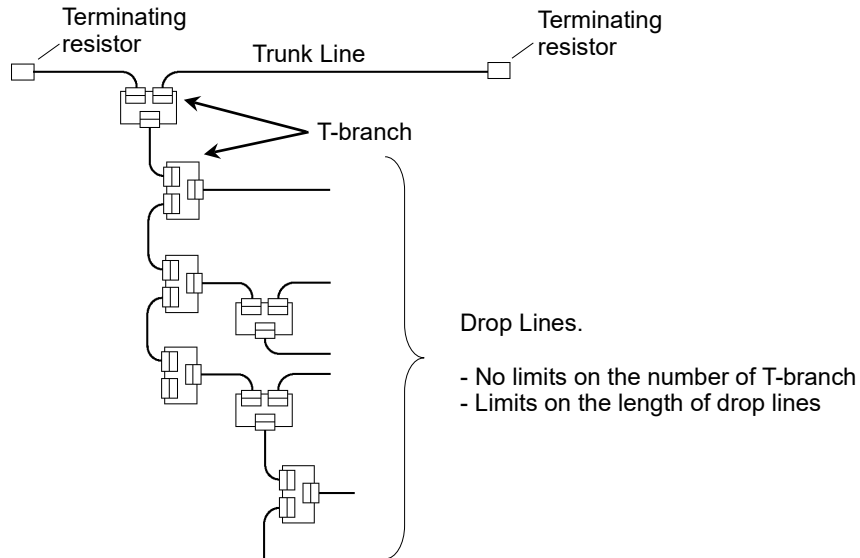

For DeviceNet, 5-wire cables are used for trunk lines and drop lines. Commercially available DeviceNet cables can be used. There are two types of DeviceNet cables: Thick cable and Thin cable. Environment-resistant cable and flexible cable are available. For details of cables, see ODVA's Web site (<https://www.odva.org/>).

Thick Cable

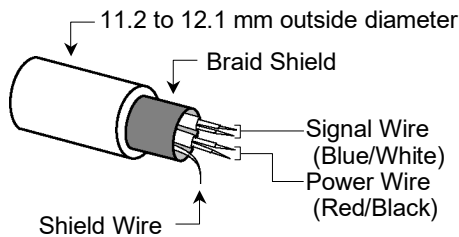

Thin Cable

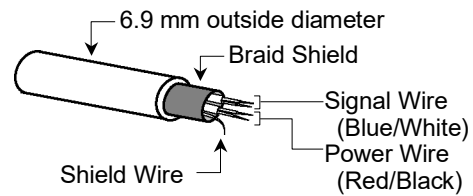

Communications Cable Signal

Wire Type	Color	Details of Signal		Wire Identity
Signal wire	Blue	Signal	Low	CAN L
	White	Signal	High	CAN H
Power wire	Red	Communications Power	Positive	V+
	Black	Communications Power	Negative	V-
Shield wire	-	Shield		S

Terminating Resistor

To reduce reflections of communication signal, terminating resistors should be attached on both ends of the trunk line. For DeviceNet, nodes have no terminating resistor on the ends.

Attach $121\ \Omega \pm 1\%$, 1/4W terminating resistors between the signal wires (CAN-H and CAN-L) of the trunk line cable. Some commercially available T-branch taps and connectors can accept terminating resistors. Molded terminating resistors with connectors are also available to attach to environment-resistant T-branch taps and connectors.

Node Connection

Nodes can be connected to a DeviceNet network by the following topologies: tree, multi-drop, T-branch, daisy chain. For tree topology, there is no limitation of daisy chain layer but drop line length is limited. For details of drop line length, refer to the following section *Drop Line Length*.

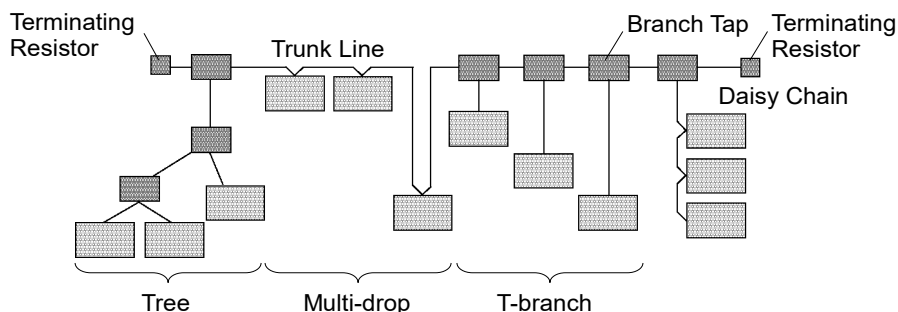

Communications Power Supply

DeviceNet supplies 24V DC communications power to each node via 5-wire cables. You must install the communications power supply at any location in the DeviceNet network. Although the power can be shared to the node internal circuit power supply and I/O power supply, it is recommended to use a dedicated communications power supply.

Shield Ground of Signal Wire

Ground the DeviceNet network at one point with $100\ \Omega$ or less.

As a noise countermeasure, you can leave the network ungrounded.

For details, refer to 4. *Trouble shooting*.

Maximum Network Length (Maximum Trunk Length)

The maximum network length is the longest distance either between terminating resistors or between the two most distant nodes on the network.

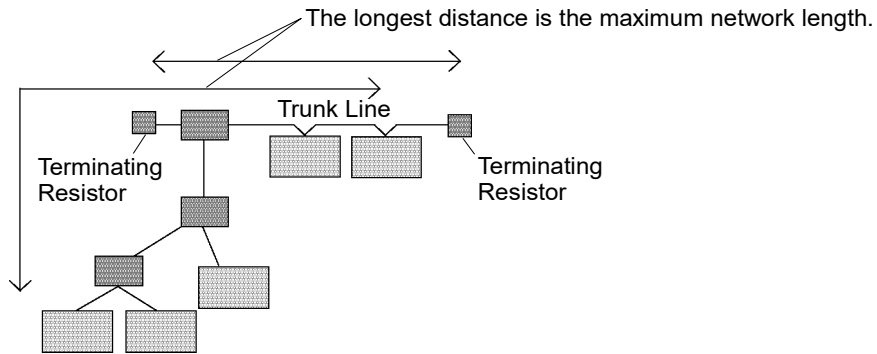

The maximum network length is determined by the type of cable and the baud rate.

Baud Rate	Maximum Network Length	
	Thick Cable	Thin Cable
500 kbps	100 m	100 m
250 kbps	250 m	100 m
125 kbps	500 m	100 m

Both Thick Cable and Thin Cable can be combined and used for trunk lines. In this case, the maximum network length is calculated using the following formulas.

Baud Rate	Maximum Network Length
500 kbps	Thick Cable Length + Thin Cable Length \leq 100m
250 kbps	Thick Cable Length + 2.5 \times Thin Cable Length \leq 250m
125 kbps	Thick Cable Length + 5.0 \times Thin Cable Length \leq 500m

Drop Line Length

Drop line length is the distance from a branch on the trunk line to the end of that branch.

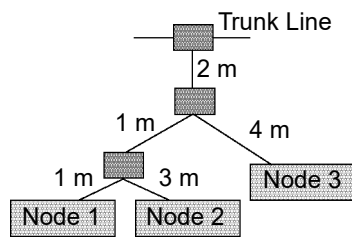

In the figure above, each drop line length is as follows:

Drop Line to Node 1: 4 m

Drop Line to Node 2: 6 m

Drop Line to Node 3: 6 m

One drop line length should be 6 m or less.

Total Drop Line Length

Total drop line length is the total distance of all drop lines in one network.

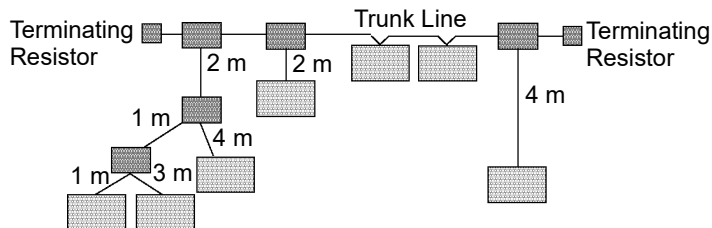

In the figure above, the total drop line length is 17 m.

The maximum total drop line length is restricted by baud rate as shown in the table below.

The cable thickness is not related to the restriction.

Baud Rate	Max. Total Drop Line Length
500 kbps	39 m
250 kbps	78 m
125 kbps	156 m

Cable Current Capacity

Current-carrying capacity of the DeviceNet network cable is restricted as below:

	Trunk Line		Drop Line (Unit: A)
	Thick Cable	Thin Cable	
Current Capacity	8A	3A	$4.57 / \text{Drop Line Length (m)} \leq 3A$

Following figures illustrate examples of power supply configuration.

When an external power supply is installed in the network as shown in the figure below, the current capacity is 11A and it exceeds the permissible current of the cable.

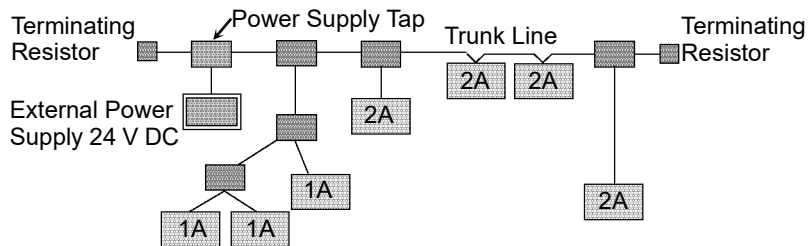

If the location of the external power supply is changed as shown in the figure below, the power supply can be used because the current capacity on the left side of the power supply tap is 5 A and 6 A on the right side.

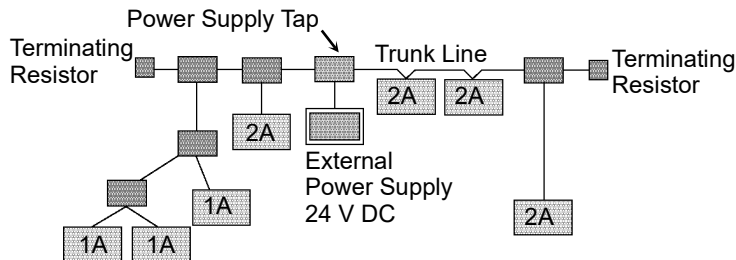

2. Installation

If the current capacity consumed in the network exceeds the restriction of cable current capacity, it is possible to install more than one power supply in the network. If you attempt to install two or more power supplies, take necessary measures (pulling out a fuse on the power supply tap, etc.) to avoid conflicts between power outputs from multiple power supplies.

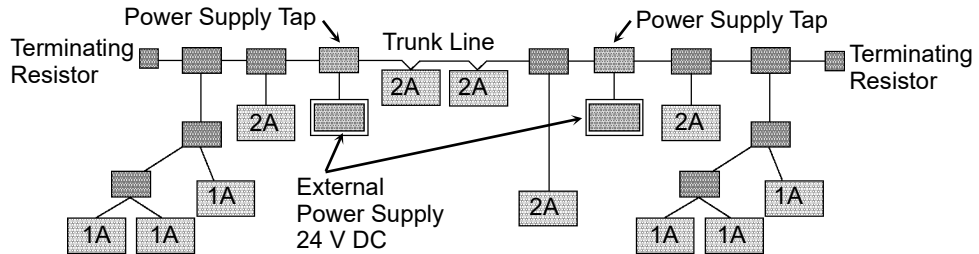

Following figure illustrates a sample wiring. An OMRON power supply tap is used in the example.

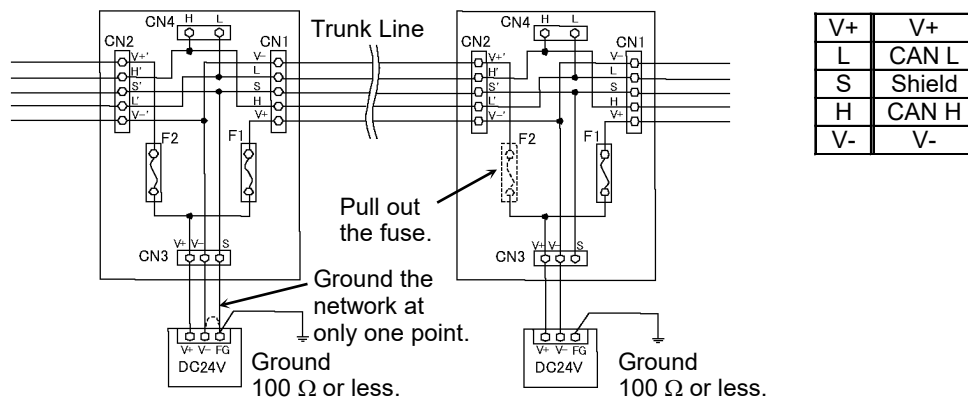

If you cannot ground the network with 100Ω or less, do not connect V- and FG wires.



CAUTION

- Carefully connect the wires. Incorrect wiring may cause node malfunction and severe damage to the entire DeviceNet network.

Modification and Installation of Communication Cables

Follow the steps described below to modify communication cables and connect them to connectors.

 CAUTION	<p>■ Be careful not to injure your hands or fingers on any sharp blades or tools used to modify the cable.</p> <p>Use appropriate blades and/or tools to modify the cable. Using inappropriate blades and/or tools may result in bodily injury and/or equipment damage.</p>
---	---

1. Strip approx. 30 mm of the cable covering with extra care so that you do not scratch on the braided shield underneath. Do not strip the cable covering more than necessary. Excess stripping may cause short-circuit and/or make the cable more sensitive to noise.

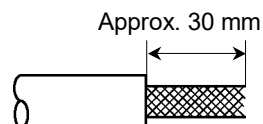

2. Carefully expand the meshes of the braided shield. Under the braided shield, there is one exposed bare twisted shield wire other than the signal wires and power wires that are wrapped with aluminum tape. The shield wire is slightly harder than the mesh.

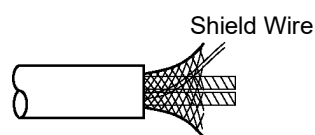

3. Cut off the expanded braided shield and remove the aluminum tape around the signal wires and power wires. Then, strip the insulation from the signal wires and power wires for a length sufficient to connect them to crimp terminals.

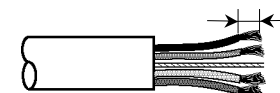

Peel the coverings in enough length to connect the wires to crimping terminals.

Twist each stripped signal wire and power wire.

4. Set the crimping terminal on the stripped part of the wire and crimp it with a crimp tool. The following crimping terminals are recommended products.

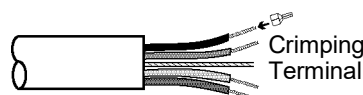

NICHIFU TC series

Model Number	Specifications	Special Tool
TMEV TC-0.5	For Thin Cable	MH-32
TMEV TC-2-11	For Thick Cable (power wire)	
TMEV TC-1.25-11	For Thick Cable (signal wire)	

Phoenix Contact AI series

Model Number	Specifications	Special Tool
AI 0.5-8WH	For Thin Cable (power wire)	CRIMPFOX UD6
AI 0.25-8YE	For Thin Cable (signal wire)	
AI 2.5-8BU	For Thick Cable (signal wire)	
AI 1-8RD	For Thick Cable (signal wire)	

- Wrap or cover the cable with vinyl tape or heat-shrink tubing.

Heat-shrinkable Tube, etc.

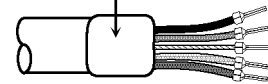

Loosen the screws securing the cables on the connector. If the screws are not loosened, the wires go into different openings on the rear of connector instead of the correct openings and the wires cannot be secured.

- Ensure the correct connector orientation and insert the signal wires and shield wire to their respective holes on the connector.

As shown in the figure, insert the wires (black, blue, shield, white, and red) into the holes in the order named.

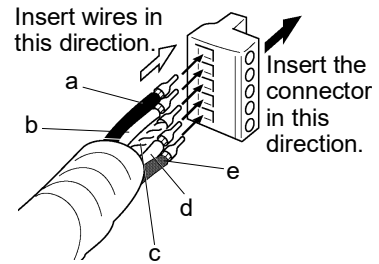

The following table shows the specified colors of the cables.

	Color	Details of Signal	Wire Identity
a	Black	Communications Power Supply (negative)	V-
b	Blue	Signal (Low)	CAN L
c	-	Shield	S
d	White	Signal (High)	CAN H
e	Red	Communications Power Supply (positive)	V+

- Tighten each screw securing the wires on the connector.

Tighten the screw securing the wire at a correct tightening torque (0.25 to 0.3 N·m).

To prevent thick cable from coming out due to cable tension, install the thick cable with enough length to allow for stretch.

Use a small flat blade screwdriver that has the correct width and thickness. If you use a typical screwdriver whose point is narrow, you cannot deeply insert it into the hole on the connector.

Specific screwdrivers for DeviceNet connector screw are:

- OMRON : XW4Z-00C
- Phoenix Contact : SZF-1 0.6×3.5

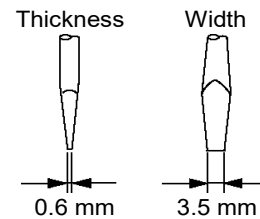

2.1.3 Installing a DeviceNet Master Board Manufactured by molex

Appearance

Part names and functions of the DeviceNet master board manufactured by molex are shown in the following figure.

For details of the status display LEDs (Module/NetWork LED and IO LED), refer to 4. *Troubleshooting* in this manual.

PCU-DVNIO

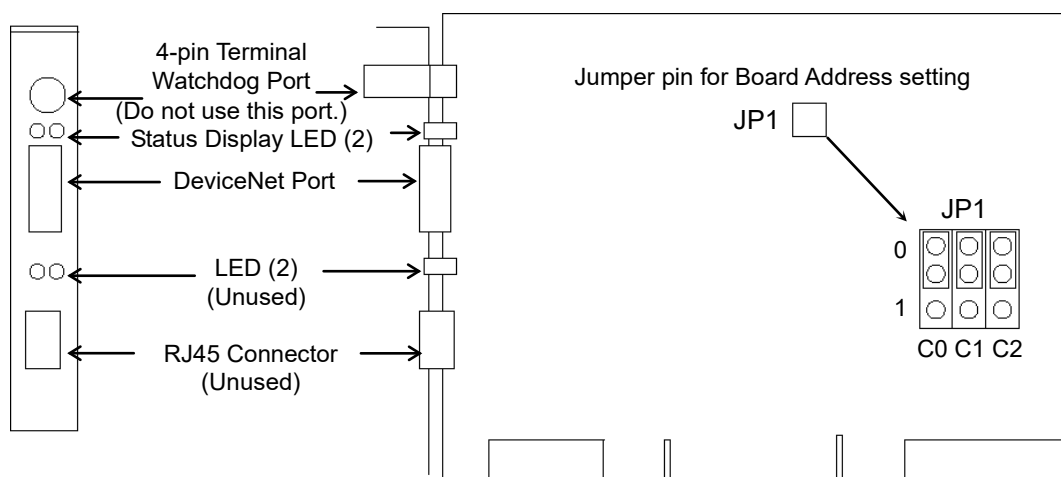

Specifications

Item	Specification
Name	DeviceNet master board manufactured by molex
Modes	Master
Baud rates	125, 250, 500 kbps
Interface	1 DeviceNet port
Supported Devices	Group 2 Only Server and U.C.M.M. capable
Maximum Nodes	63
Connection Types	Strobe, Polling, Cyclic and Change of State
Explicit Messaging Connection	Yes
EDS Support	Yes
Max. Input Data Size	1024 bits (128 bytes)
Max. Output Data Size	1024 bits (128 bytes)
Automatic Detection	Yes. Devices can be detected automatically.

Modes

DeviceNet master board manufactured by molex has the master mode and slave mode as motion modes. However, do not select the slave mode.

Master mode

The master device gathers and controls all nodes on one network.

DeviceNet master can control up to 64 nodes (max. 128 bytes) in one network.

PLC is typically configured as a master and controls all nodes in factory automation system, but Epson RC+ is also capable of being a master.

DeviceNet network configuration is specified by configuration management software. This is normally provided by a master device manufacturer. The configuration management software determines parameters for each slave device via an Electronic Data Sheet (EDS).

Available connection types are Polling, Strove, Cyclic, Change Of State, and Explicit messaging.

Available baud rates are 125 kbps, 250 kbps, and 500 kbps.

For the instruction of configuration, refer to *Master Mode* later in this chapter.

Installing Software

Before adding DeviceNet master boards manufactured by molex to the PC with the Epson RC+ 8.0 installed, you must install the applicomIO Console application and drivers according to the type of the board you are using.

1. Insert the applicomIO Console CD-ROM to the PC with the Epson RC+ 8.0 installed.
2. The dialog box shown below appears. Select “Run setup.exe”.

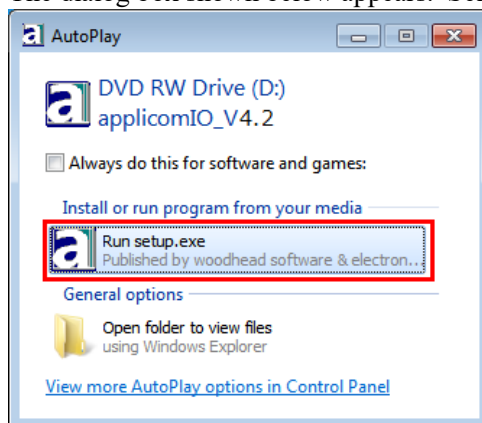

3. The [Summary] dialog box appears. Select “Product Installation”.



4. The [Installation] dialog box appears. Select “applicomIO”.

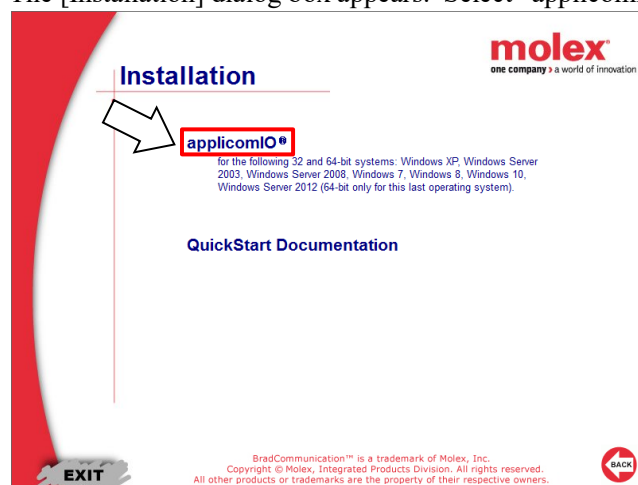

- 5. If the Microsoft.NET Framework 4.0 is not installed, following dialog box appears.

Click [Install].

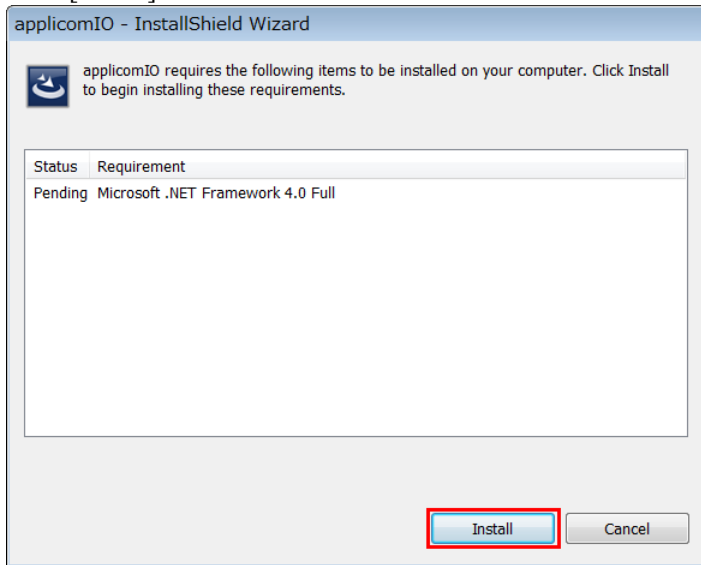

- 6. The applicomIO Console application installer runs and the [Welcome to the InstallShield Wizard for applicomIO] dialog box appears.

Click [Next].

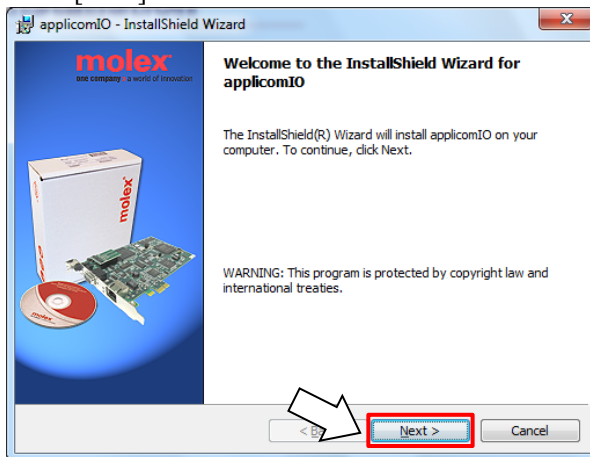

- 7. The [License Agreement] dialog box appears.

Read the software license agreement and click [Next].

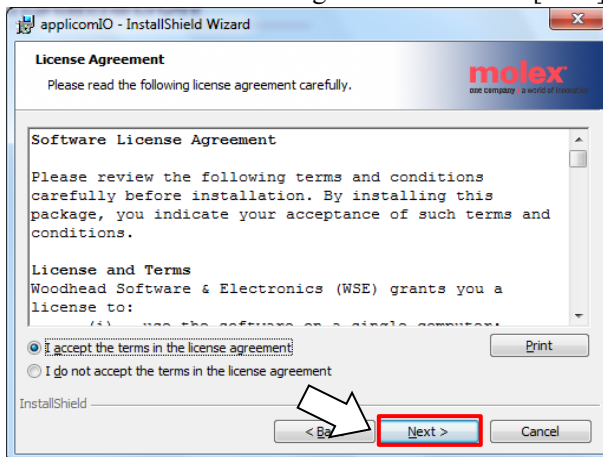

8. The [Customer Information] dialog box appears. Now register the user information. Enter the User Name and Organization.

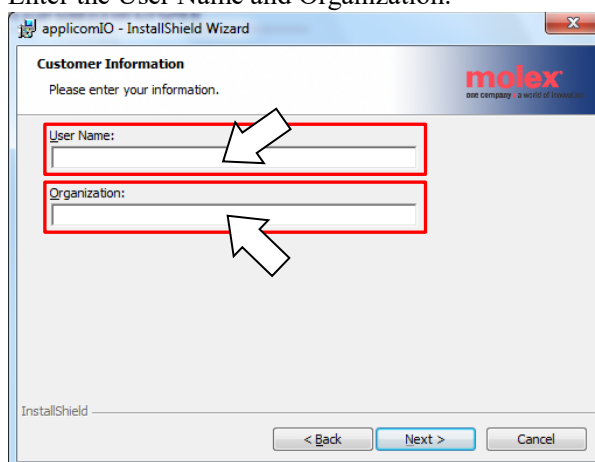

9. The [Destination Folder] dialog box appears. Specify the installation folder for the applicomIO Console application. The default specifies here:
C:\Program Files(x86)\BradCommunications\applicomIO\4.2
If you agree to the default installation folder, click [Next].



10. The [Ready to Install the Program] dialog box appears. Click [Install].

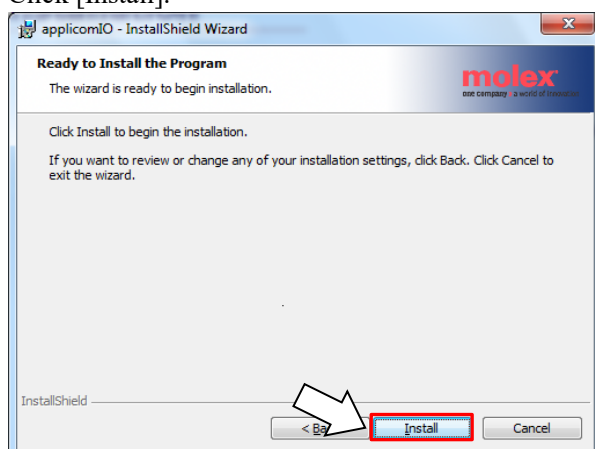

11. Installation of applicomIO Console application starts.
After the installation completes, the [InstallShield Wizard Completed] dialog box appears.

Click [Finish].

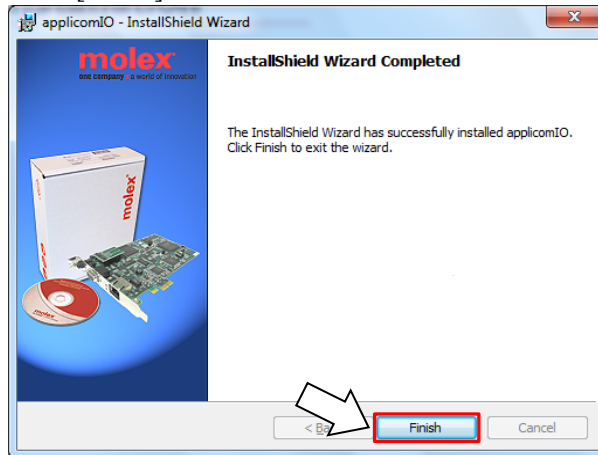

12. The message prompting you to reboot your PC appears.

Select [Yes] and reboot the PC.

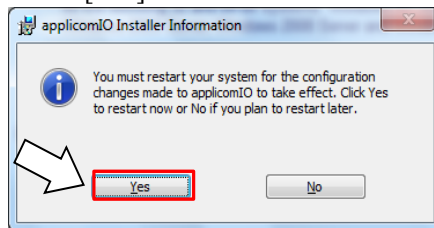

13. Refer to the next section *Installing a Board* to install the DeviceNet master board manufactured by molex.

Installing a Board



- Make sure that the power is turned OFF before installing/removing any boards or connecting/disconnecting any cables. Working with the power ON is extremely hazardous and may result in electrical shock and/or malfunction of equipment.

1. Configure the board address jumper (JP1) on DeviceNet master board manufactured by molex.

You can install one Fieldbus master board to the PC with Epson RC+ 8.0 installed. The board number should be “1”.

Refer to the following table for JP1 configuration.

Board No.	Short Socket	C0	C1	C2
1		0: Short	0: Short	0: Short

2. Install the DeviceNet master board manufactured by molex to the PCI bus of the PC with the Epson RC+ 8.0 installed. Installation methods of the DeviceNet master board manufactured by molex to the PCI bus and how to open the cover differ depending on the type of PC. Refer to the manuals of each PC on how to install the board to the PCI bus.
3. Connect the DeviceNet master board manufactured by molex with the DeviceNet network.
4. Start up the PC.
5. Open the [applicomIO Console] installation folder and start the “applicomIO Console” application.

Following is specified for [applicomIO Console] installation folder as default.

C:\Program Files(x86)\BradCommunications\applicomIO\4.2



consoleio.exe

6. The [applicomIOR console] dialog box appears. Add the DeviceNet master board manufactured by molex.

Click [Add Board].

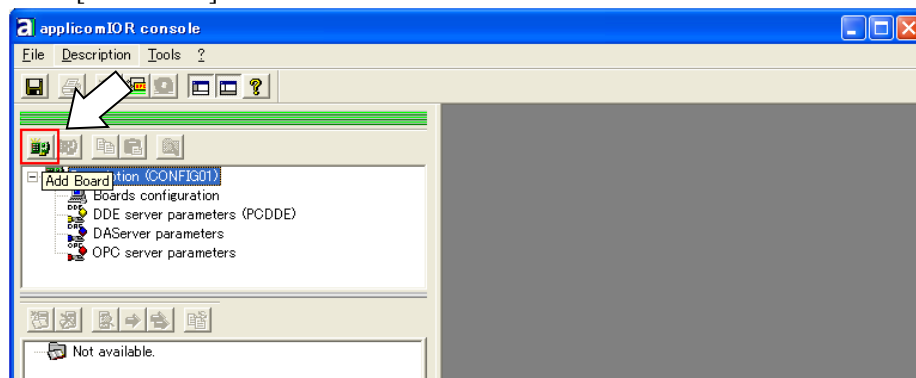

- 7. The [Add New Board] dialog box appears. Confirm that “PCU-DVNIO” is displayed in [Board to Add]-[Board Type] and click [OK].

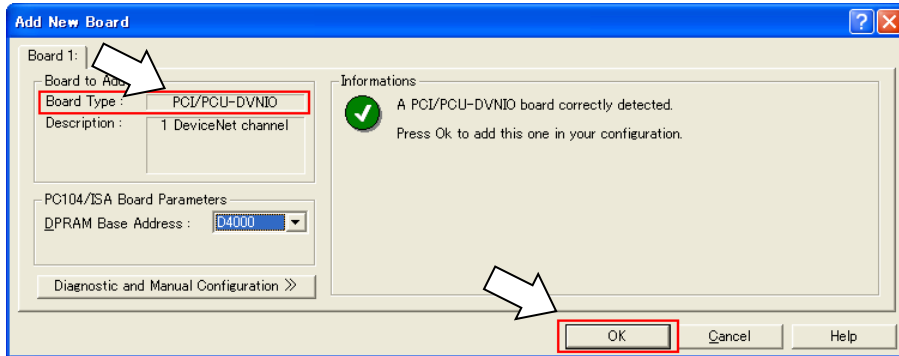

If the board cannot be detected, the following dialog box appears. Make sure that the board is correctly inserted.

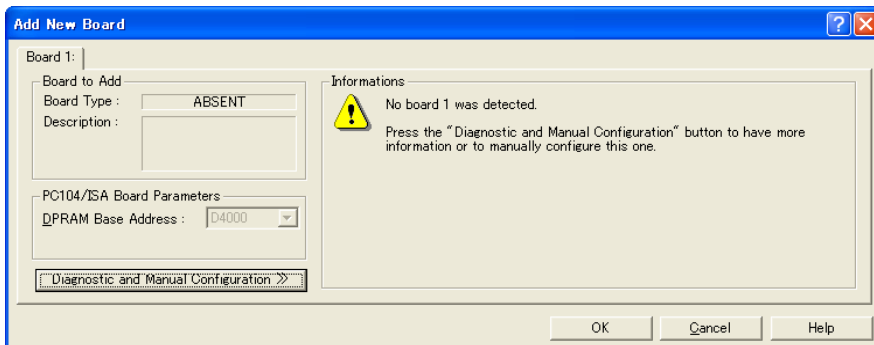

- 8. When you finish adding the DeviceNet master board manufactured by molex to the applicomIO Console application, reboot the PC.

- 8-1 Shutdown the applicomIO Console application.

- When the applicomIO Console application shuts down, the dialog box below appears. Click [Yes].

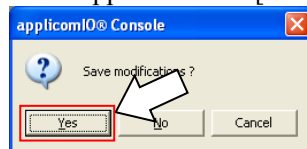

- 8-2 Then, the following dialog box appears. Click [OK].

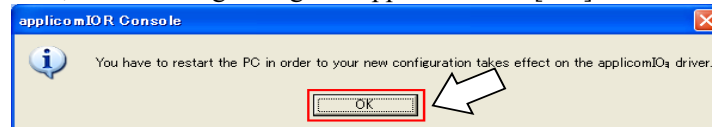

- 8-3 Reboot the Windows.

- 9. After the PC is rebooted, refer to the next section *Master Mode* and continue the step.

Master Mode

1. Check that the DeviceNet master board manufactured by molex is connected to the DeviceNet network.
2. Open the [applicomIO Console] install folder and run the “applicomIO Console” application.
Following is specified for [applicomIO Console] install folder as default.
C:\Program Files(x86)\BradCommunications\applicomIO\4.2



consoleio.exe

3. The [applicomIOR console] dialog box appears. Register the device information (EDS file) that is necessary for the network setup.

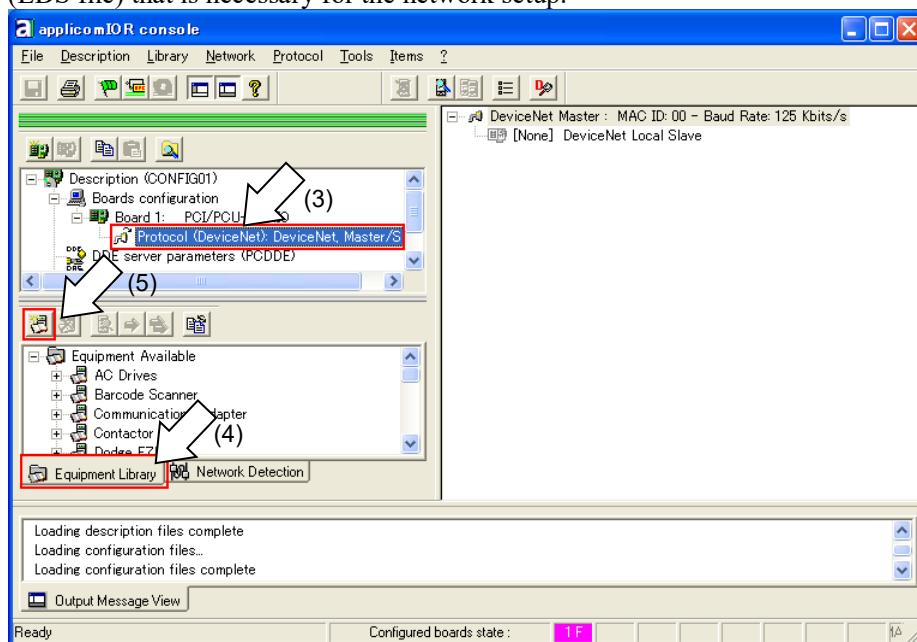

4. Select [Protocol].
5. Select the [Equipment Library] tab.
6. Click [Add].
7. The [Select configuration files] dialog box appears. Specify the EDS file that is supplied by the device manufacturer. Click [Open].

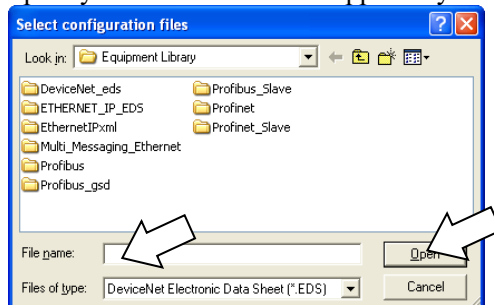

8. Select [Protocol]-[Properties] from the applicomIOR console menu.

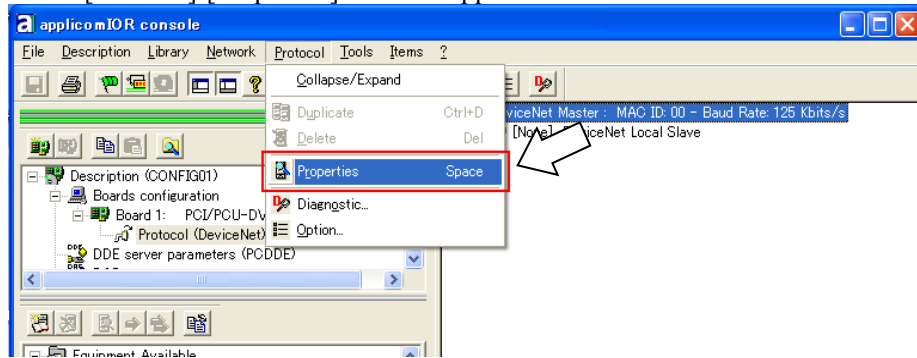

9. The [Device Net Master] dialog box appears. Configure the Baud Rate, MAC ID (master address), and so on for the DeviceNet network. When the master setting is completed, click [OK].

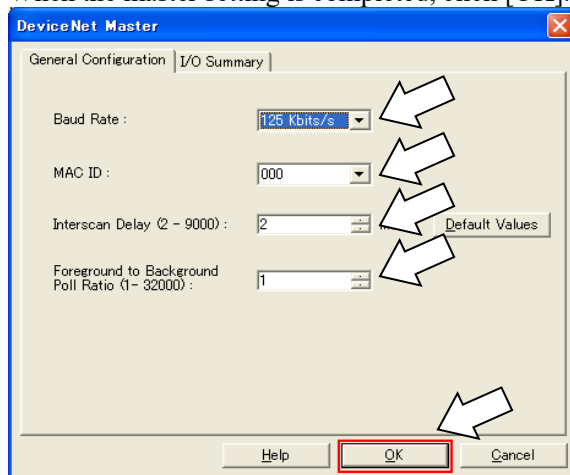

NOTE

Load on a bus can be controlled by the Baud Rate and Interscan Delay settings. When the load exceeds 60%, the DeviceNet network communication will be unstable, for example, more communication errors. Set the configuration to minimize the load.

For verification of the load on the bus using the applicomIO Console application, refer to 4. *Troubleshooting* in this manual.

10. Select [Network Detection].

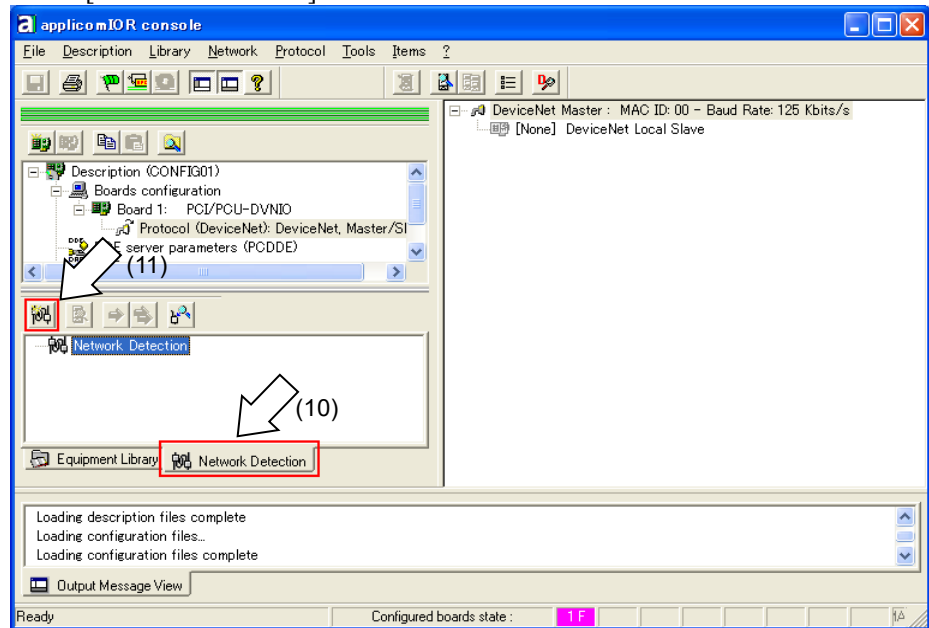

11. Click [Read Network Configuration].
12. The following message appears. Click [Yes].

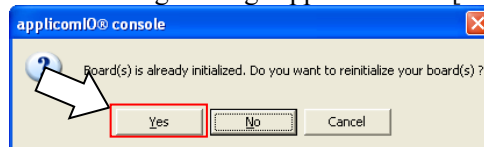

13. The [Network Detection] dialog box appears and the devices on the Fieldbus will be read in.



14. The list of detected devices is displayed in [Network detection] panel.

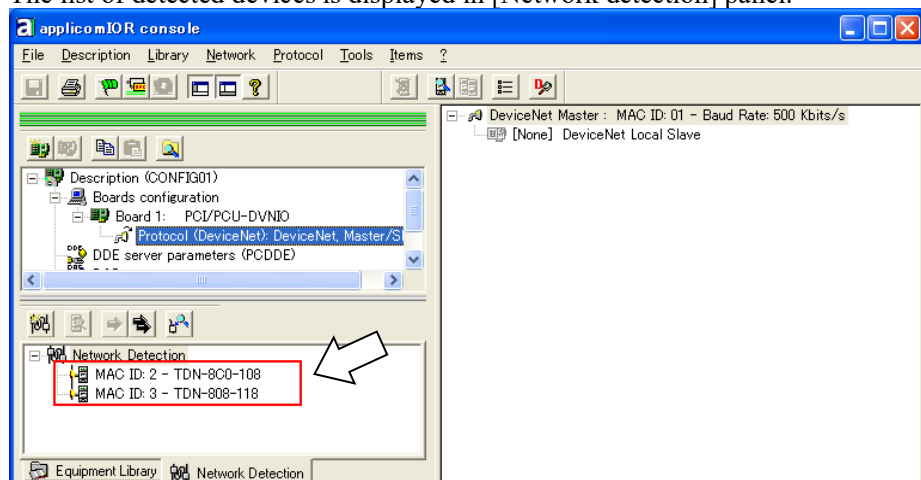

15. Select a device you want to scan.

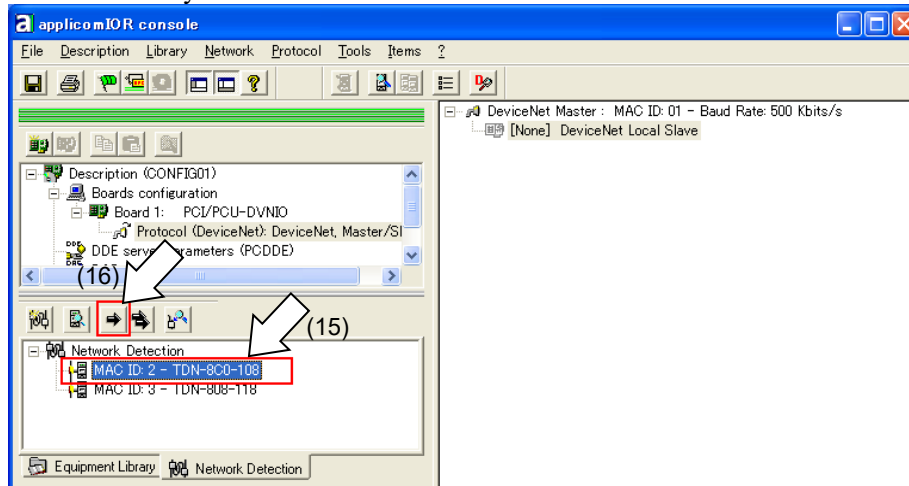

16. Click [Insert in Configuration].
17. The following dialog box appears.

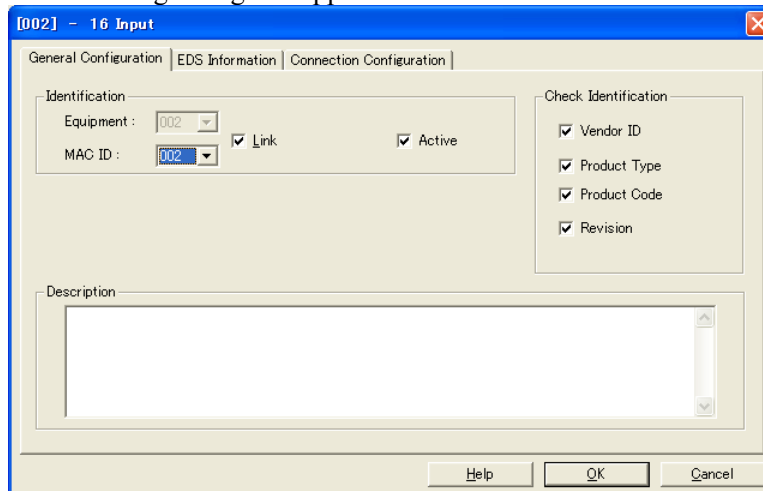

17-a Select [Connection Configuration] tab. Connections Parameters appear to communicate with the slave device.

- Displayed items are different depending on the slave device.
- Displayed Connections Parameters are information that is set on the Fieldbus master board. Confirm that the information matches with that of the slave device.

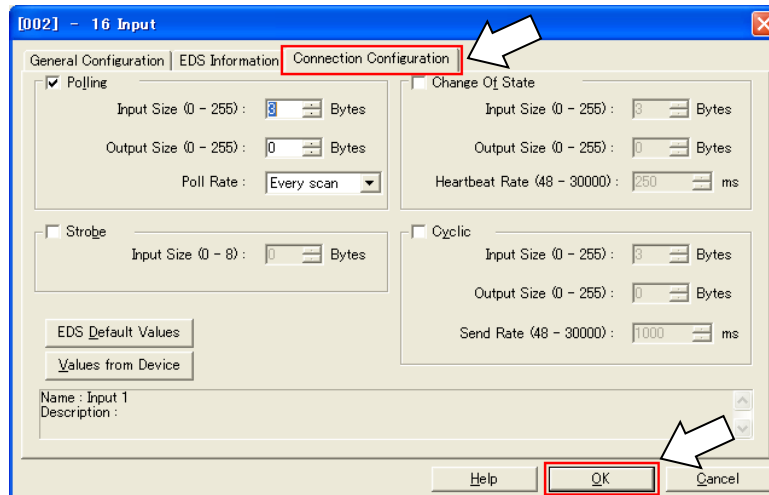

Change parameters as necessary.
After completing setting, click [OK].

NOTE

Connections Parameters that are set for the Fieldbus master board and information of the slave device need to be matched.

Communication with the slave device is not performed if they do not match. Change the information of either Connections Parameters or Fieldbus master board.

Please consult with the slave device manufacturer if the information is unclear.

- 17-b [Expert Mode] will appear when the applicomIO Console application is used in the “Expert Mode”.

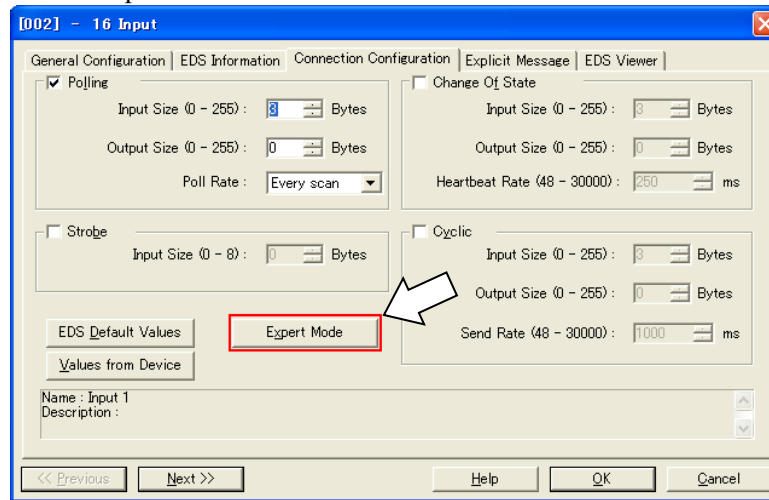

To configure details of “Change Of State” and “Cyclic”, click [Expert Mode] and display the [Expert Mode] dialog box.

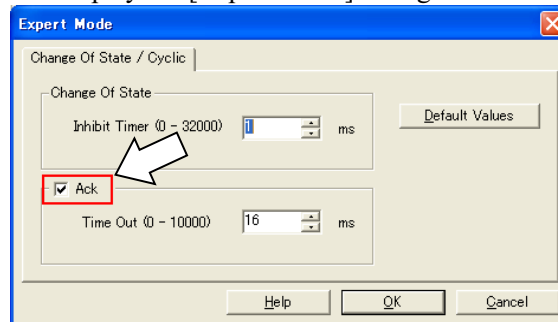

NOTE

Never disable [Ack]. When the [Ack] checkbox is unchecked, a failed connection is not regarded as an error.

- 17-c When the system cannot identify the device you want to use (its EDS file is not registered), the following dialog box will appear.

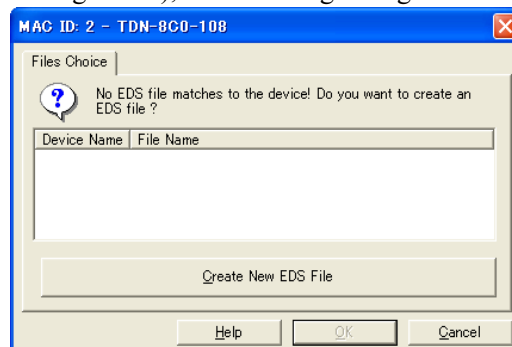

In this case, obtain the EDS file from the device manufacturer and register it by following the step 7. After that, follow the step 10.

18. Check the communication status with each slave devices.
Click [Diagnostic].

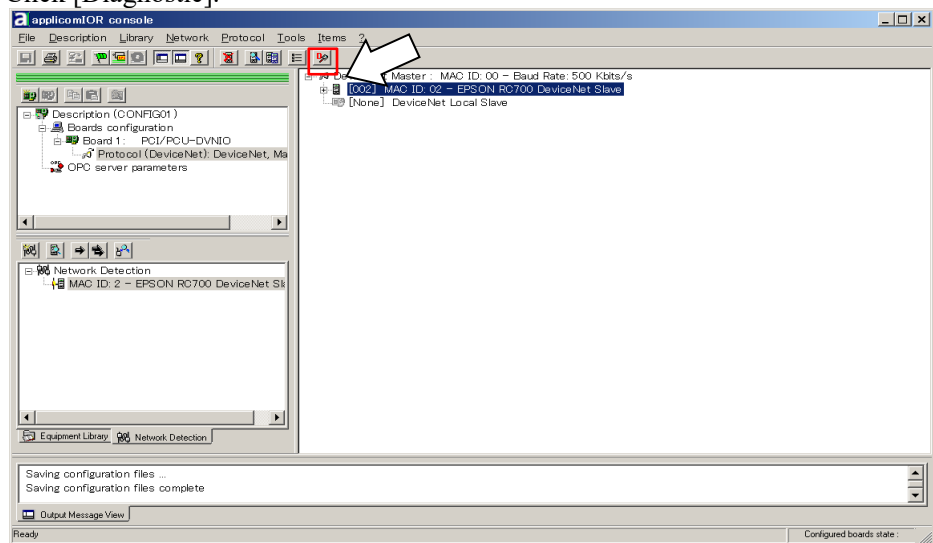

19. The [Diagnostic Board] dialog box appears.

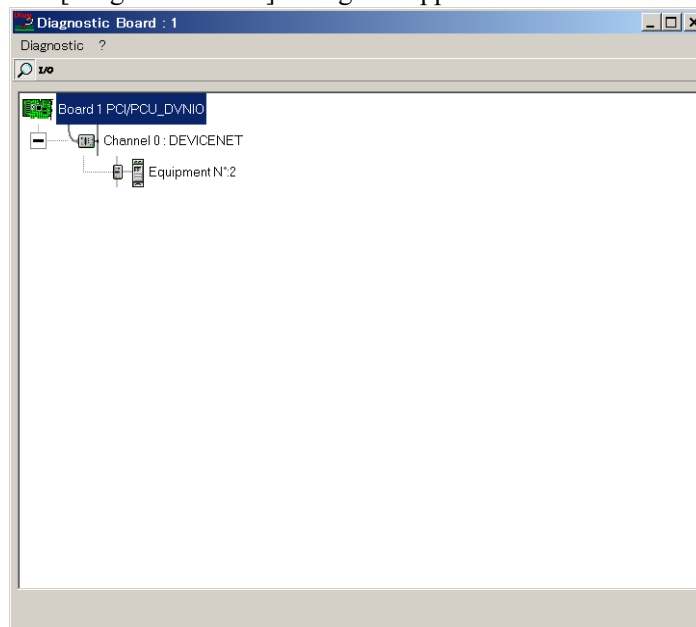

2. Installation

If it cannot communicate with the slave device, the following dialog box appears.

Connections Parameters for the Fieldbus master board and information of the slave device may not be matched.

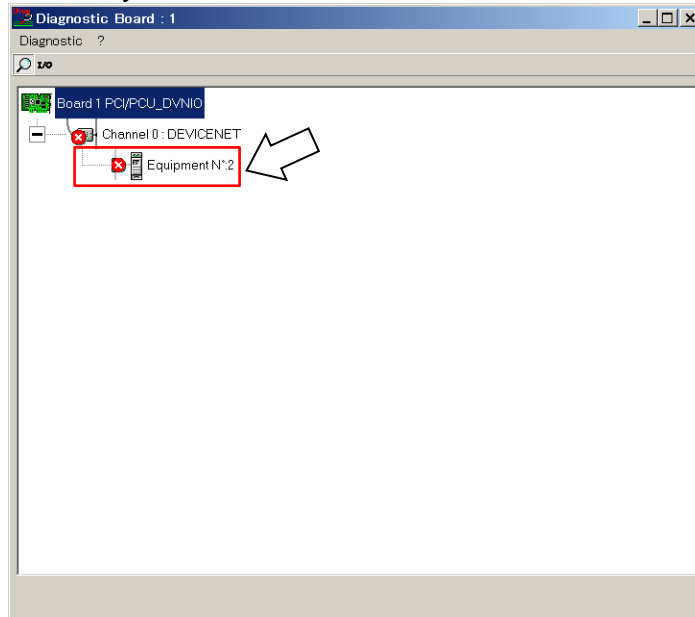

Connections Parameters for the Fieldbus master board can be checked by the following procedure.

First, select the slave device which is registered to the Fieldbus master board.

Then, click the left mouse button and select [Properties].

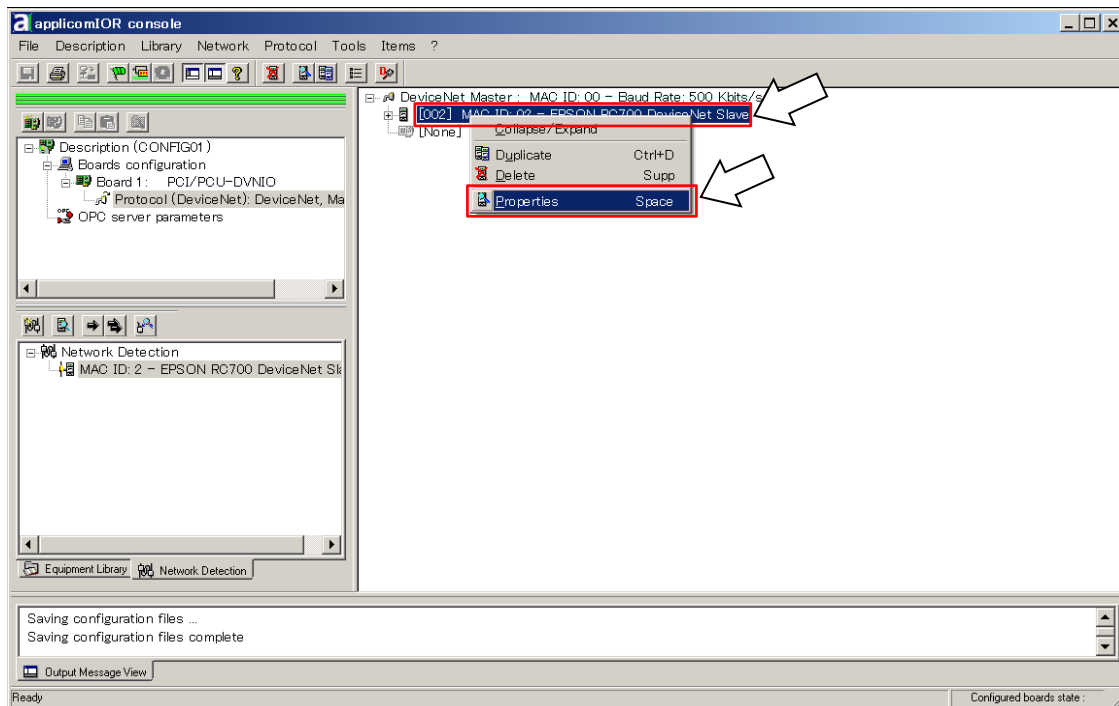

The property information of selected slave device is displayed.

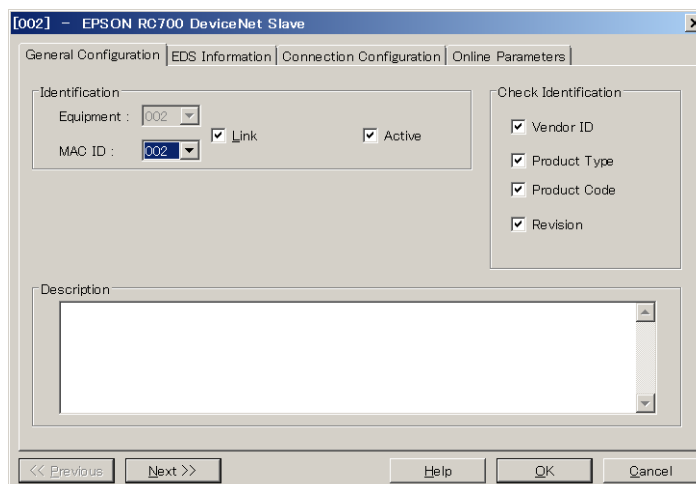

Select the [Connection Configuration] tab.
Connections Parameters appear to communicate with the slave device.

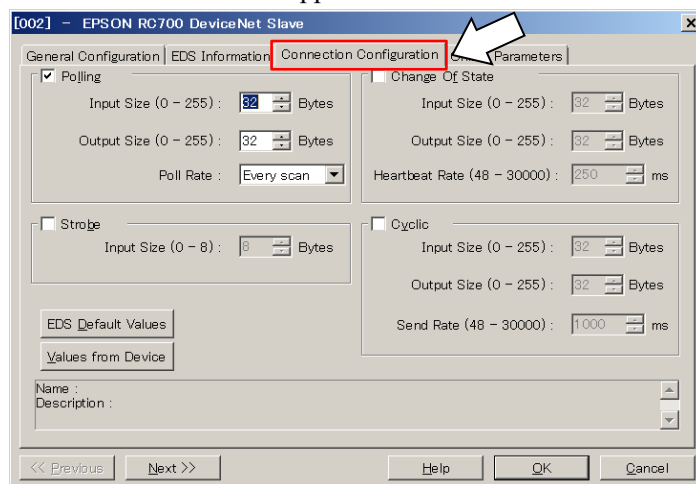

20. Select [File]-[Download in Flash] from the applicomIOR console menu. Register the configuration to the Fieldbus master board.

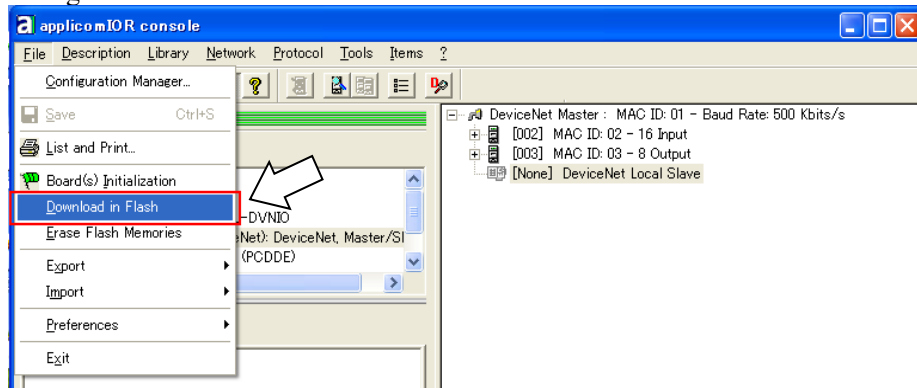

Make sure that the flash memory of Fieldbus master board stores the configuration; otherwise the Fieldbus master board cannot correctly function. Also, you cannot control it from Epson RC+ 8.0.

If you changed the configuration, select [File]-[Download in Flash] from the applicomIOR console menu and register the configuration to the fieldbus master board.

21. After few seconds, the display of “Configured boards state” on the status bar turns to green.

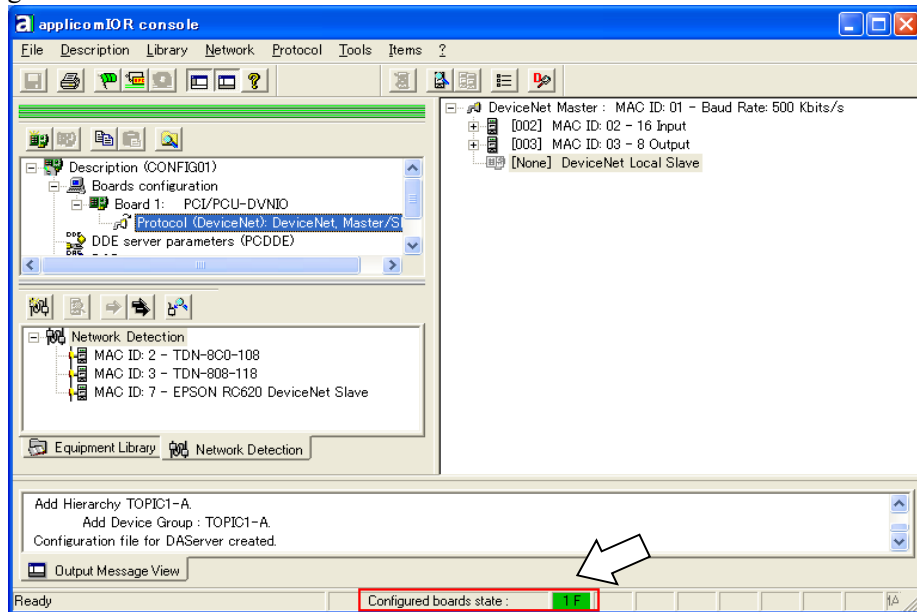

Now, the Fieldbus master board is ready to operate in the master mode.

22. Close the “applicomIO Console” application.
23. Refer to the next section *Epson RC+ 8.0 Configuration* and continue the step.



If there is a problem such as the fieldbus master board is not recognized by Windows, make sure that the combination is described in "Control System Configuration" in the preface of this manual and refer to the following section.

4. Troubleshooting
 - 4.4 How to Disable Fast Startup in Windows

Epson RC+ 8.0 Configuration

To use the Fieldbus master board, the Robot system option setting and Fieldbus master setting should be enabled on Epson RC+ 8.0.

1. Select [Setup]-[License Configuration] and display the [License Configuration] dialog box.
2. Refer to the *Epson RC+ User's Guide: Installing Controller Licenses* and enable the Fieldbus Master option.
3. When the following message displays, click the [OK] button.

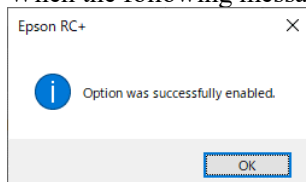

4. Select [Setup]-[System Configuration] and display the [System Configuration] dialog box.
5. Select [Controller]-[Inputs/Outputs]-[Fieldbus Master]-[General].

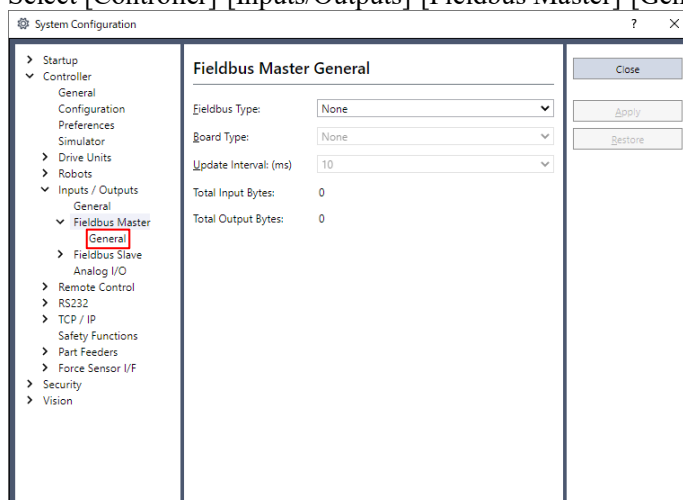

6. Set the following items:
 [Fieldbus Type:] DeviceNet
 [Board Type:] Molex
 [Update Interval:] Update cycle for the DeviceNet master I/O

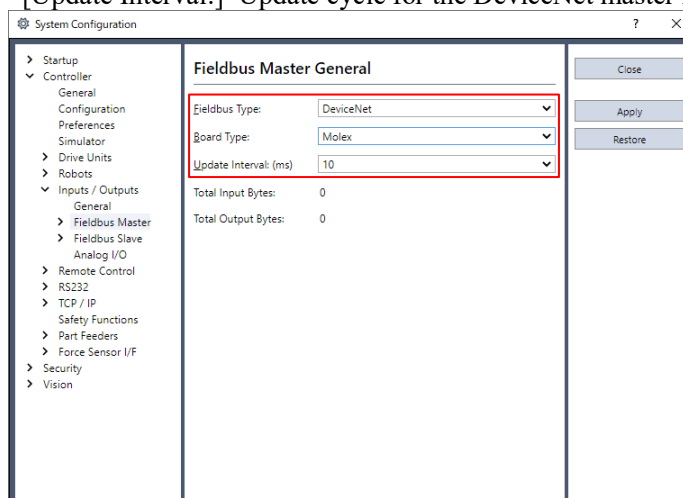

7. Click [Apply].
 Confirm that the following items are displayed.
 Total Input Bytes : Number of inputs the master controls (Bytes)

2. Installation

Total Output Bytes : Number of outputs the master controls (Bytes)

- Click [Close]. The following dialog box appears. The Robot Controller automatically starts rebooting.



- Select [Setup]-[System Configuration] and display the [System Configuration] dialog box.
- Select [Controller]-[Inputs / Outputs].

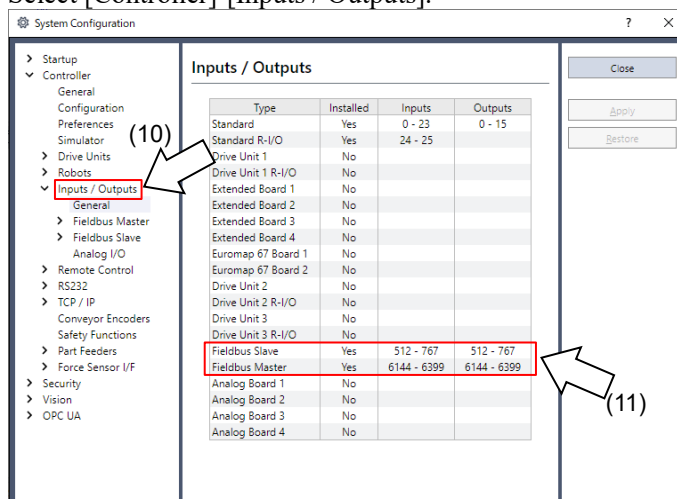

- Confirm that "Fieldbus master" displays the following items:
 Installed : Yes
 Inputs : "6144" – "6144 + Number of inputs the master controls (Bits)"
 Outputs : "6144" – "6144 + Number of outputs the master controls (Bits)"

- Select [Fieldbus Master]-[General].

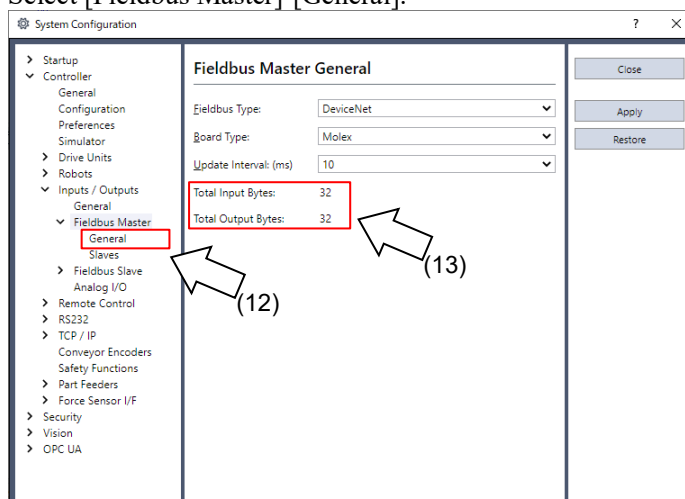

- Confirm that the following items are displayed.
 Total Input Bytes : Number of inputs the master controls (Bytes)
 Total Output Bytes : Number of outputs the master controls (Bytes)

14. Select [Fieldbus Master]-[Slaves].

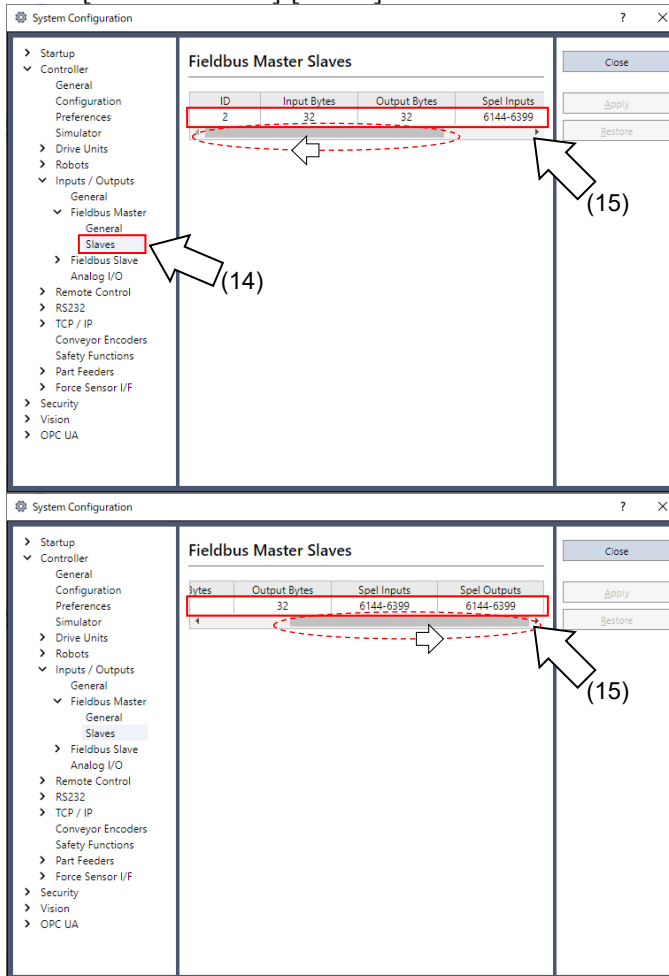

15. Confirm that the following information the master controls is displayed.

- ID : Fieldbus station ID of slave
- Input Bytes : Number of inputs per slave (Bytes)
- Output Bytes : Number of outputs per slave (Bytes)
- Spel Inputs : Number of inputs per slave (Bits)
- Spel Outputs : Number of outputs per slave (Bits)

2.1.4 Installing a DeviceNet Board Manufactured by Hilscher

Appearance

PCI: CIFX 50-DN

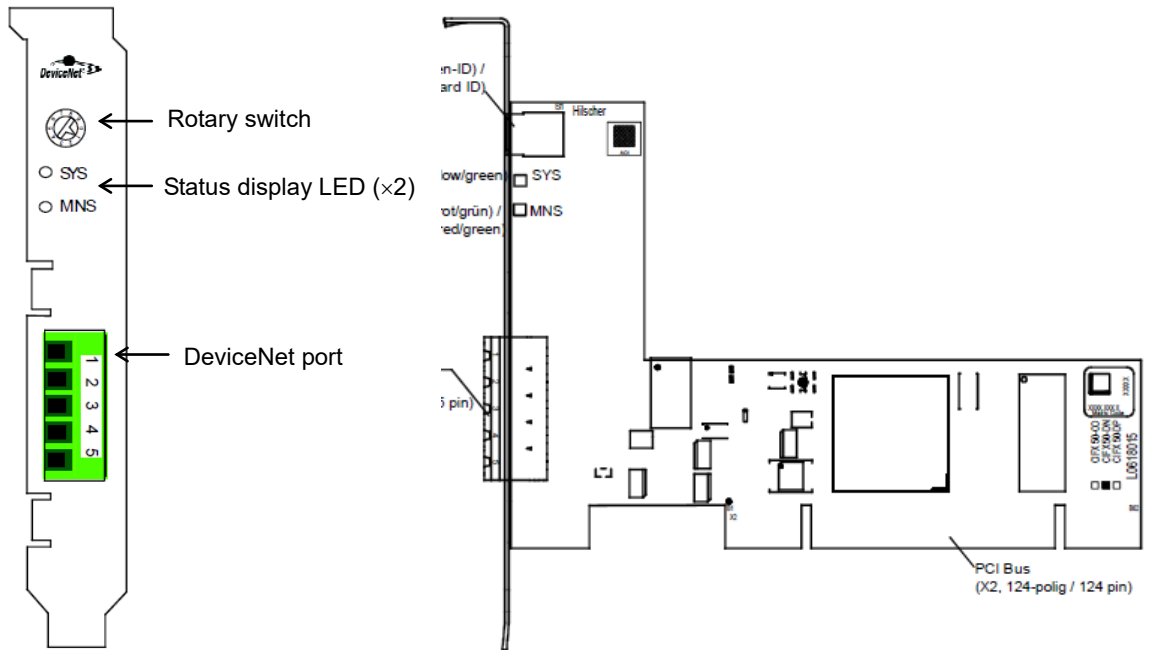

PCI Express: CIFX 50E-DN

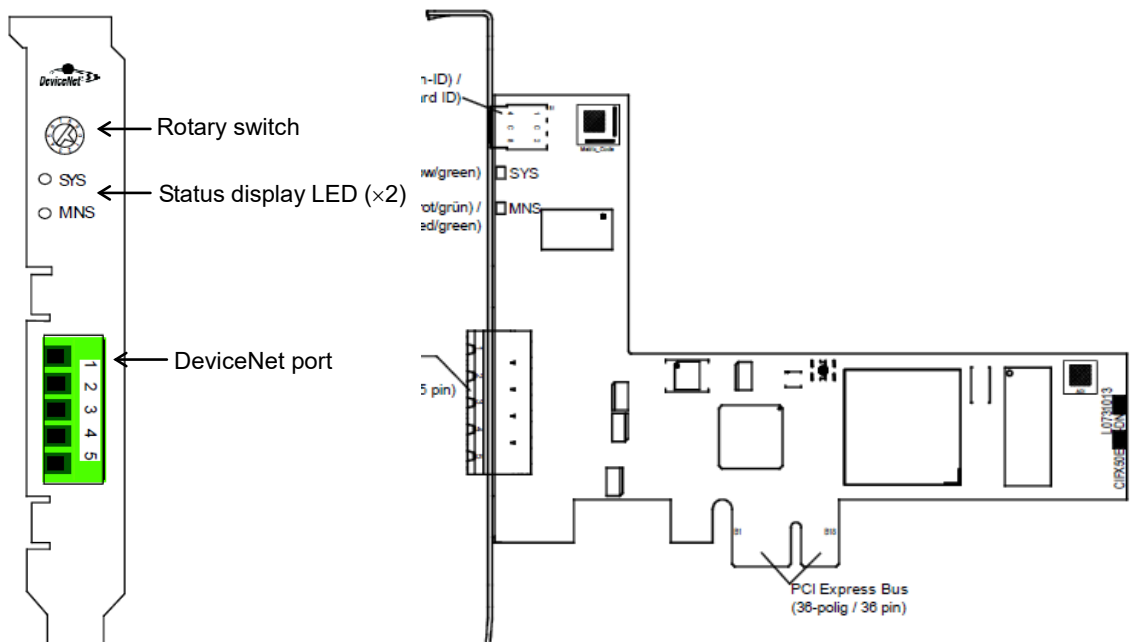

Specifications

Item	Specification
Name	DeviceNet board manufactured by Hilscher
Maximum number of DeviceNet slaves	63
Maximum number of total cyclic input data	3584 bytes
Maximum number of total cyclic output data	3584 bytes
Maximum number of cyclic input data	128 bytes/connection
Maximum number of cyclic output data	128 bytes/connection
Maximum Configuration data	1000 bytes/slave
Acyclic communication	Explicit connection All service codes are supported
Connections	Bit Strobe Change of State Cyclic Poll Explicit Peer-to-Peer Messaging
Function	Quick Connect
Fragmentation	Explicit and I/O
UCMM	Supported
Objects	Identity Object (Class Code 0x01) Message Router Object (Class Code 0x02) DeviceNet Object (Class Code 0x03) Connection Object (Class Code 0x05) Acknowledge Handler Object (Class Code 0x06)
Baud rates	125 kBits/s, 250 kBit/s, 500 kBit/s Auto baud rate detection is not supported
Data transport layer	CAN frames

LED Description







LED state represents the status of the fieldbus board.

SYS: System Status LED

LED state	Description
Green	Operating in normal condition
Flashing Green/Yellow	Waiting for firmware to load
Yellow	Waiting for firmware (netX) to load
OFF	The power supply to the device is missing or hardware may have faults.

MNS: Module Network Status LED

For the DeviceNet Master protocol, the communication status LED MNS can assume the states described below.

LED	Color	State	Description
MNS	Duo LED red/green		
	 (Green)	ON	Device operational and on-line, connected: Device is online Connections with all slaves are established.
	 (Green)	Flashing (1 Hz)	Device operational and on-line: Device is online No connection is established. - Configuration missing, incomplete or incorrect
	 (Green, Red, OFF)	Flashing (2 Hz) Green, Red, OFF	Self test after power ON.
	 (Red)	Flashing (1 Hz)	Minor fault and/or connection time-out: Device is online One or more connections are established. Device has data exchange with at least one of the configured slaves or no data exchange with one of the configured slaves.
	 (Red)	ON	Critical fault or critical link failure: Critical connection failure Device has detected a network error. Duplicate MAC-ID or severe error in CAN network.
	 (OFF)	OFF	Device is not powered - The device may not be powered. Device is not on-line and/or no network power - The device has not yet complete the Dup_MAC_ID test. - The device is powered. The network power is missing.

2. Installation

LED state	Description
Flashing (1 Hz)	The indicator turns ON and OFF with a frequency of approx. 1 Hz. Turn ON for 500 ms, followed turn OFF for 500 ms.
Flashing (2 Hz) Green, Red, OFF	The indicator turns to green on for 250 ms, and red on for 250 ms, then turn OFF.

Setting of Rotary Switch

Use a rotary switch of DeviceNet board manufactured by Hilscher at “0” position.

Modes

DeviceNet board manufactured by Hilscher has the master mode and the slave mode. However, do not use in the slave mode.

Master mode

The master device gathers and controls all nodes on DeviceNet network.

DeviceNet board manufactured by Hilscher can control up to 63 nodes (max. 128 bytes per slave) in one network.

PLC is typically configured as a master and controls all nodes in factory automation system, but Epson RC+ is also capable of being a master.

DeviceNet network configuration is specified by configuration management software. This is normally provided by a master device manufacturer. The configuration management software determines parameters for each slave device via an Electronic Data Sheet (EDS).

Available connection types are Bit Strobe, Change of State, Cyclic, Poll, and Explicit Peer-to-Peer Messaging.

Available baud rates are 125kbps, 250kbps, and 500kbps.

Installing Software

Installing device driver

Before adding DeviceNet board manufactured by Hilscher to the PC with the Epson RC+ 8.0 installed, you must install the Hilscher SYCON.net application and drivers according to the type of the board you are using.

1. Insert Communication-Solutions DVD into the PC with Epson RC+ 8.0 installed.
2. Open the [Communication-Solutions DVD \Driver_ & Toolkit\Device Driver (NXDRV-WIN)\Installation] folder of Communication-Solutions DVD. Execute cifX Device Driver Setup.exe.
3. The [User Account Control] dialog box appears. Click [Yes].

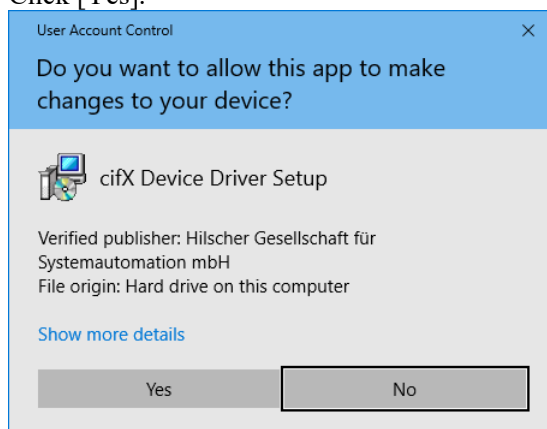

4. The [Device Driver Setup] dialog box appears. Select the [I accept the terms in the License Agreement] check box. Click [Install].

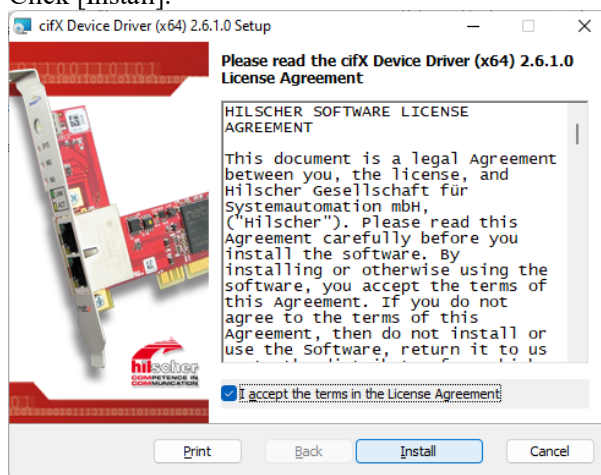

5. The [Windows Security] dialog box appears. Click [Install].
6. When the dialog box switched, click [Install] again.

- The [Completed the cifX Device Driver (x64) 2.6.1.0 Setup Wizard] dialog box appears.
Click [Finish].



Installing master application software

- Open the [Communication-Solutions DVD \ Software_ & _Tools\Configuration_Software\SYCON.net] folder of Communication-Solutions DVD.
Execute SYCONnet netX setup.exe.
- When Windows Security Alert appears, do not click [Cancel] and proceed to the next step.
- The [User Account Control] dialog box appears.
Click [Yes].

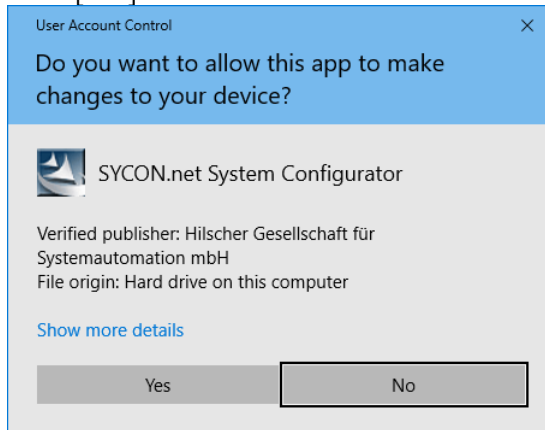

- The [Choose Setup Language] dialog box appears.
Select “English [USA]” and click [OK].

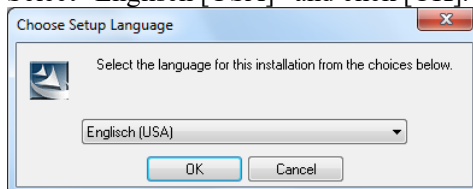

Now, start the installation.

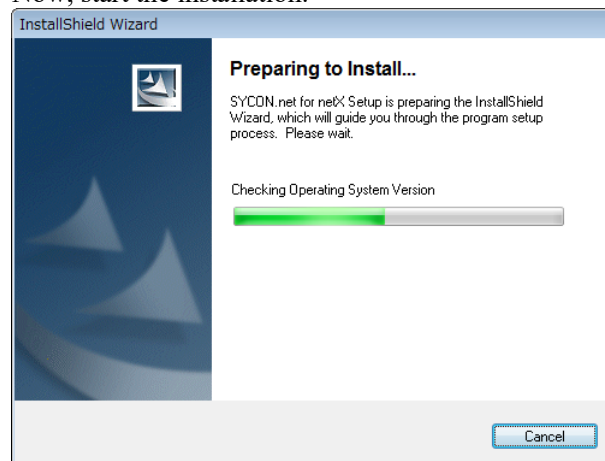

5. The [InstallShield Wizard - Welcome] dialog box appears. Click [Next].

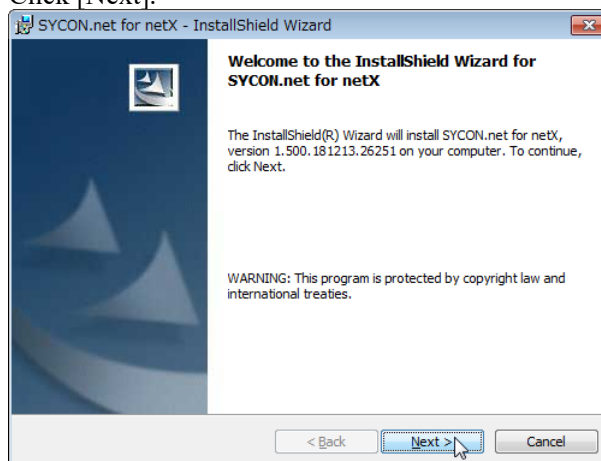

6. [InstallShield Wizard - Important Information] dialog box appears. Select [I read the information]. Click [Next].

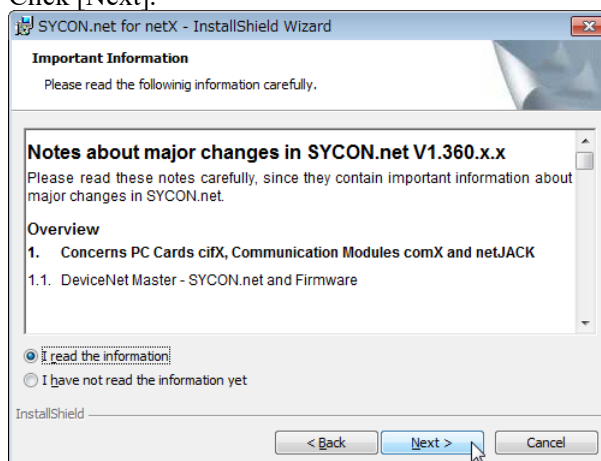

- The [InstallShield Wizard - License Agreement] dialog box appears. Select [I accept the terms in the license agreement]. Click [Next].

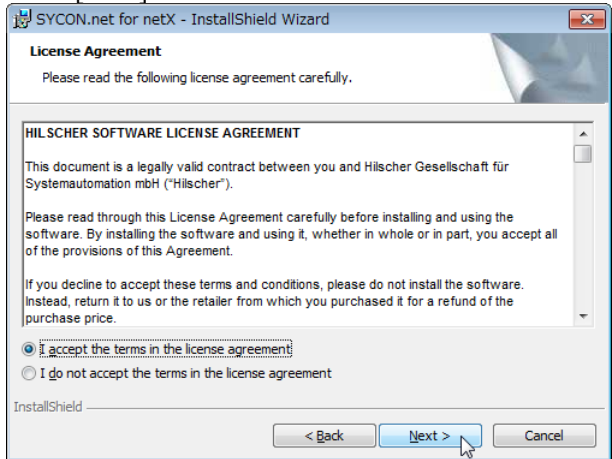

- The [InstallShield Wizard - Customer Information] dialog box appears. Enter the User Name and Organization. Click [Next].

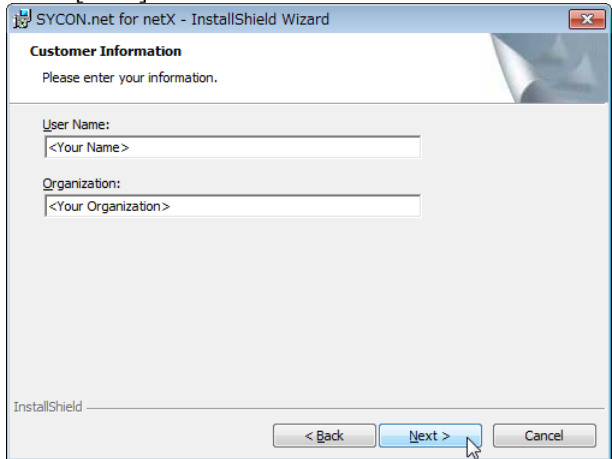

- The [InstallShield Wizard - Ready to Install the Program] dialog box appears. Click [Install].

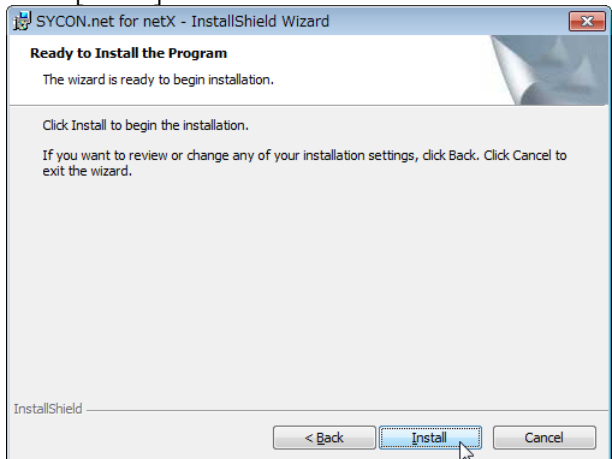

Now, start the installation.

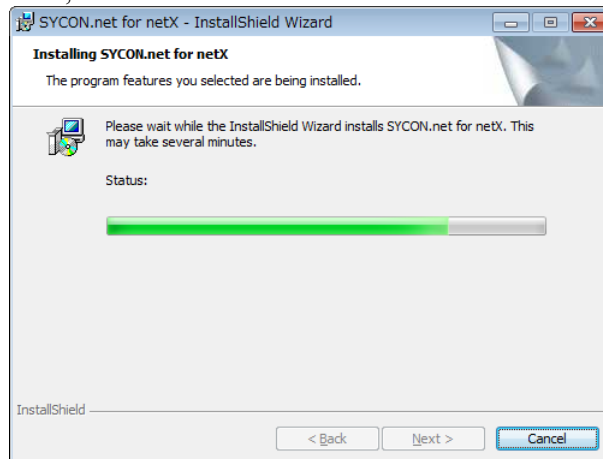

10. The [InstallShield Wizard - InstallShield Wizard Completed] dialog box appears. Click [Finish].

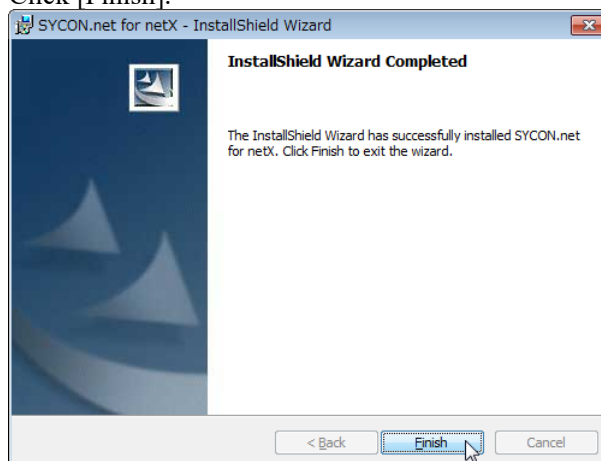

Refer to the next *Installing a Board* and install DeviceNet board manufactured by Hilscher.

Installing a Board

1. Configure the rotary switch of the board address on DeviceNet board manufactured by Hilscher.

You can install one Fieldbus master board to the PC with the Epson RC+ 8.0 installed. The slot number should be “Not in use (0)”. Refer to the following table for configuration.

Slot No.	Rotary switch position
Not in use	0
Slot No. 1	1
Slot No. 9	9

2. Install the DeviceNet board manufactured by Hilscher to the PCI bus or PCI Express bus of the PC with Epson RC+ 8.0 installed.

Installation methods of the DeviceNet board manufactured by Hilscher to the PCI bus/PCI Express bus and how to open the cover differ depending on the type of PC. Refer to the manuals of each PC on how to install the board to the PCI bus/PCI Express board.

3. Connect DeviceNet board manufactured by Hilscher with the DeviceNet network.
4. Describe an example to set the master and the slave as the setting below.

Setting item	Value
Master MACID	0
Slave MACID	1
Baud Rate	500 kbps
Slave Input Bytes	20 bytes
Slave Output Bytes	20 bytes

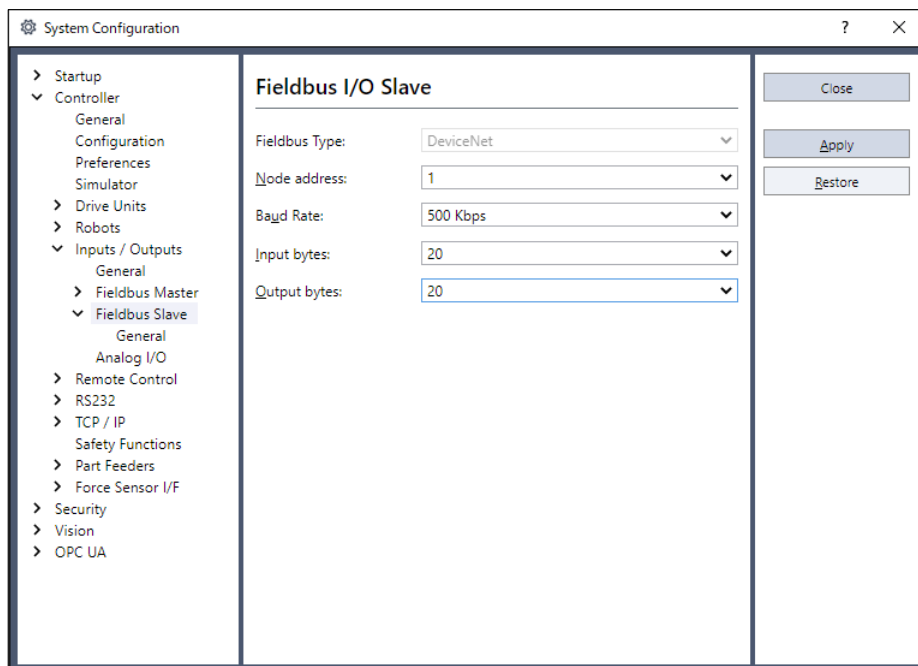

5. Start up the PC.

6. Select the Start menu-[SYCON.net] and execute it.

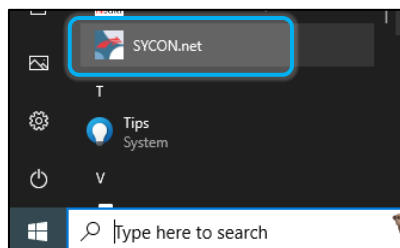

7. Set a Confirm password of SYCON.net.
Click [OK].
Be careful not to forget the Confirm password.

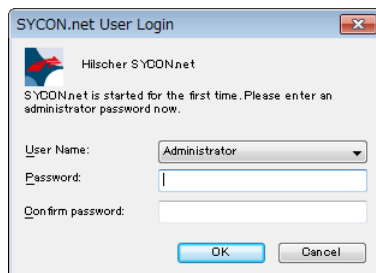

8. SYCON.net starts up.
Click [netDevice]-Device Catalog list on the right side-[CIFX DN/DNM].

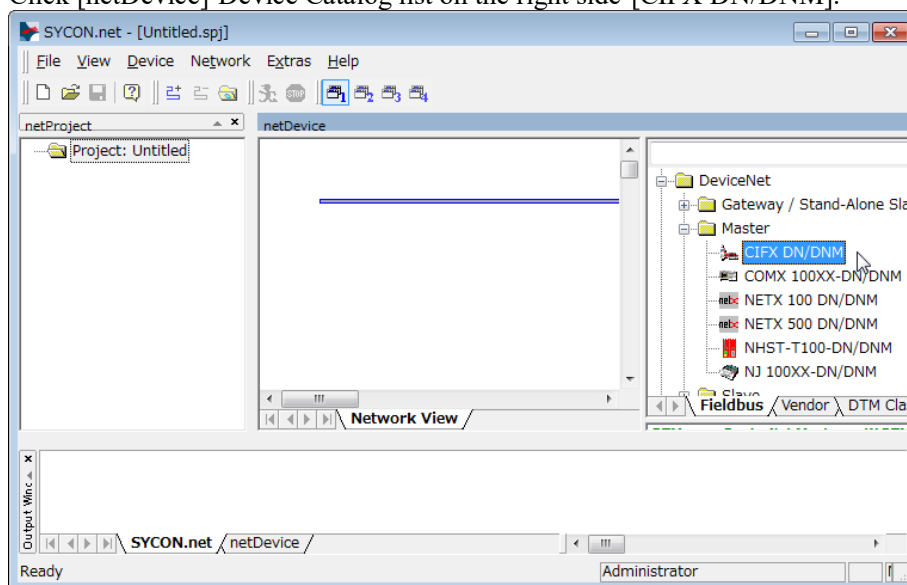

Importing slave EDS files

- 9. Click [Network]-[Import Device Descriptions...].

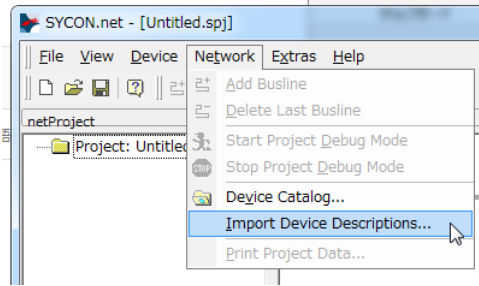

- 10. [Import Device Description] dialog box appears.
From [Files of type], select "DeviceNet EDS."
Select EDS files provided by each device manufacturer and click [Open].

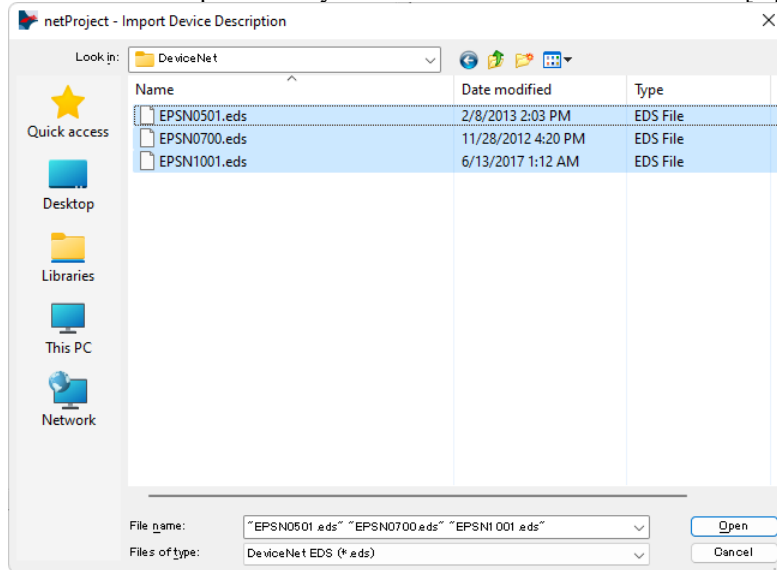

- 11. The following message appears.
Click [Yes]. EDS files are imported.

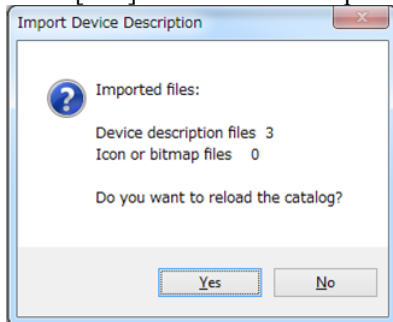

Adding a master icon

12. Click SYCON.net application software-[netDevice]-Device Catalog list on the right side-[DeviceNet]-[Master]-[CIFX DN/DNM].

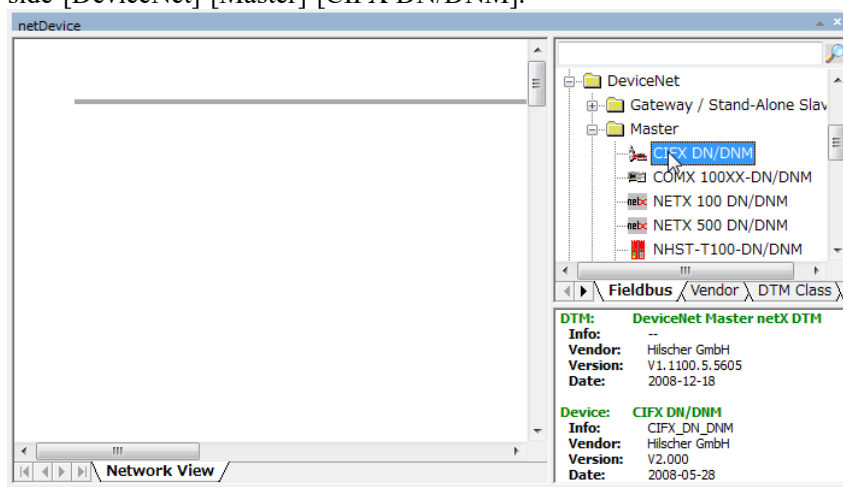

13. Drag & drop [CIFX DN/DNM] on the bold line on the left side of [netDevice].

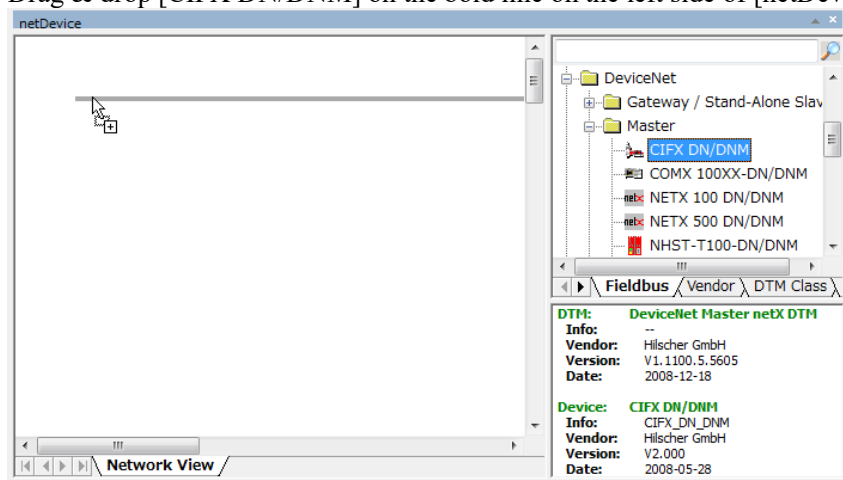

14. "CIFX_DX_DNM" icon indicating DeviceNet board manufactured by Hilscher is connected.

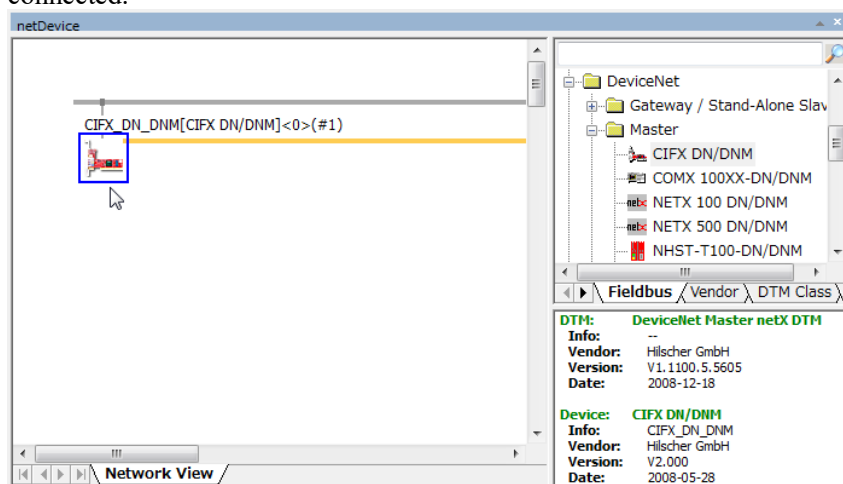

Adding a slave icon

- 15. Click SYCON.net application software-[netDevice]-Device Catalog list on the right side-[DeviceNet]-[Slave]-Slave device.

In case of DeviceNet slave module:

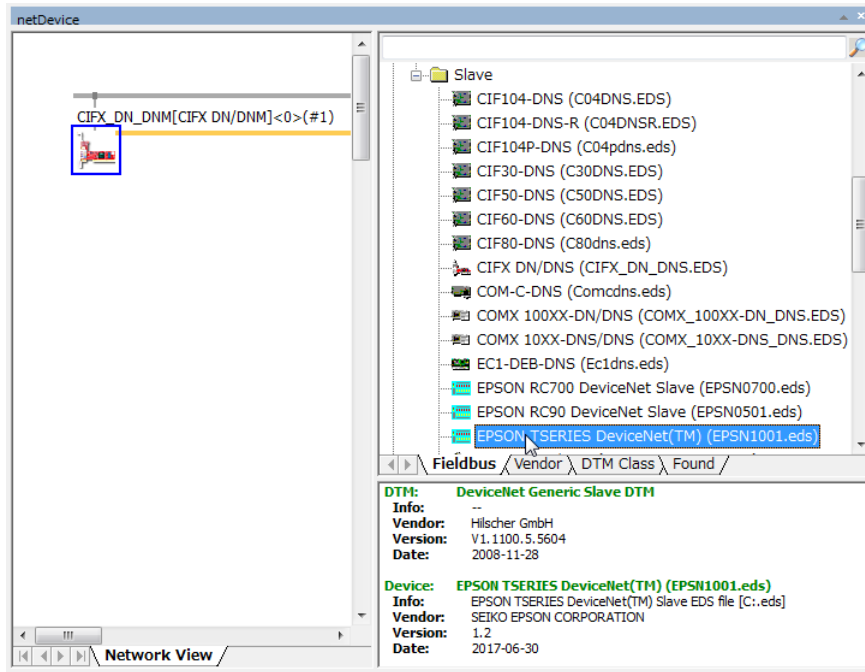

- 16. Drag & drop the selected slave device on the bold line on the left side of [netDevice].

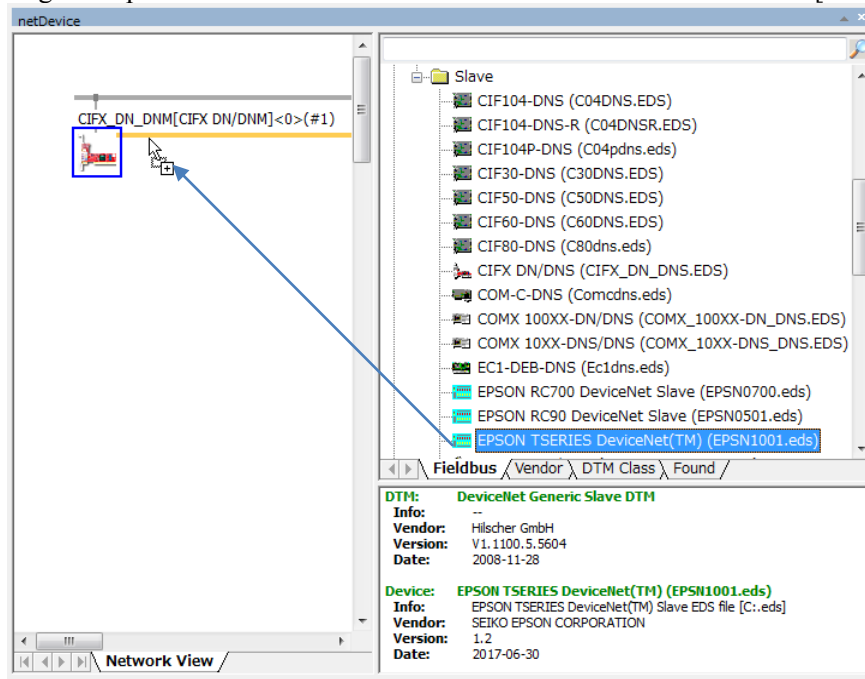

17. DeviceNet Slave is connected and the icon appears.

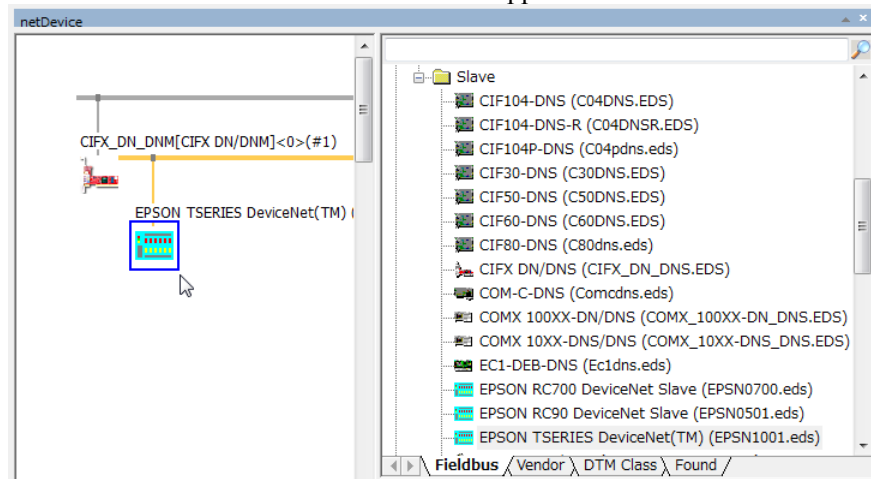

Setting on master side

18. Right-click [netDevice]-[CIFX_DN_DNM] and click [Configuration...].

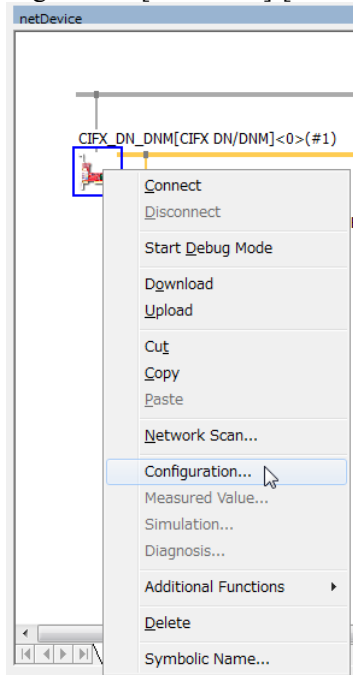

19. The [Configuration] dialog box appears.
Select [Settings]-[Device Assignment] tab.
Select the installed [CIFX 50E-DN] checkbox and click [Apply].

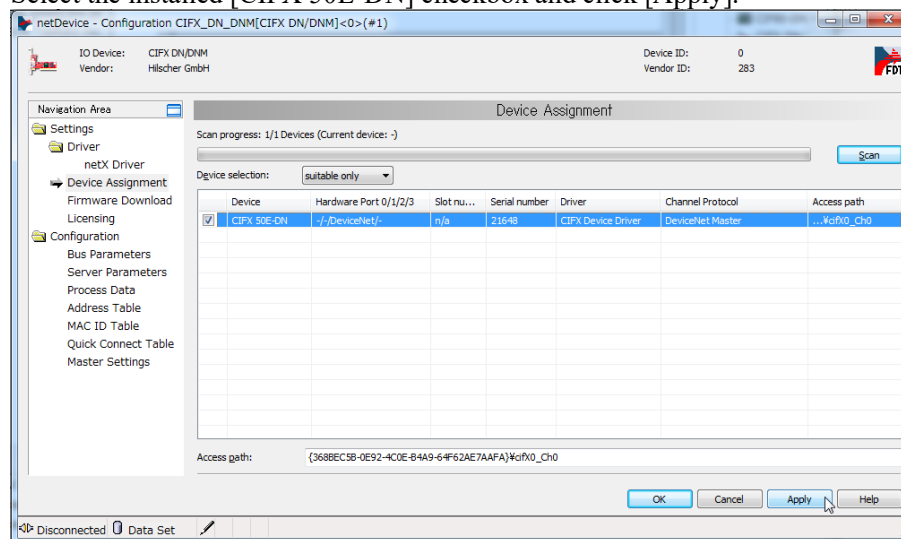

20. Select [Settings]-[Driver]-[Firmware Download].
Click [Browse...].

21. Display the [Firmware,_EDS,_Examples,_Webpages\Firmware_&_EDS\COMSOL-DNM V2.4.0.4\COMSOL-DNM V2.4.0.4\Firmware\cifX] folder of Communication-Solutions DVD.
Select [C0206000.nxf].
Click [Open].

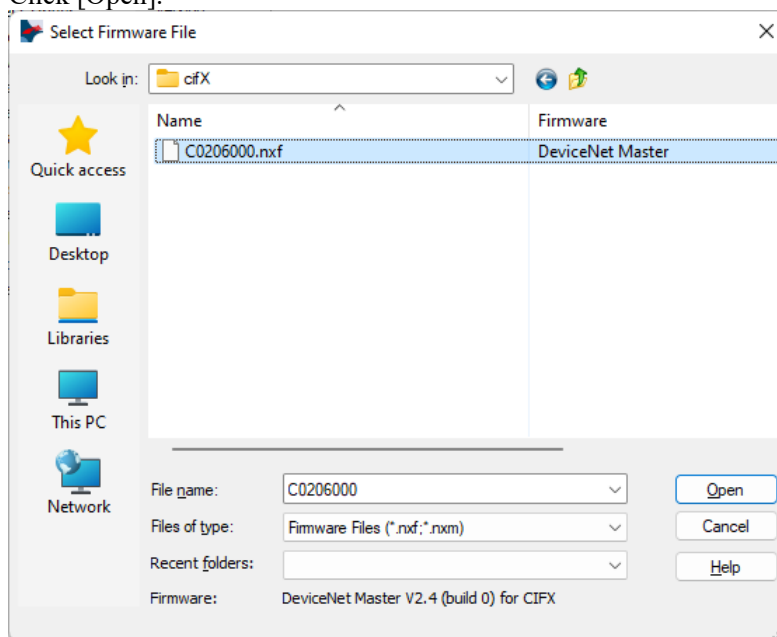

22. Confirm that [Name] is “DeviceNet Master for CIFX”.
Click [Download].

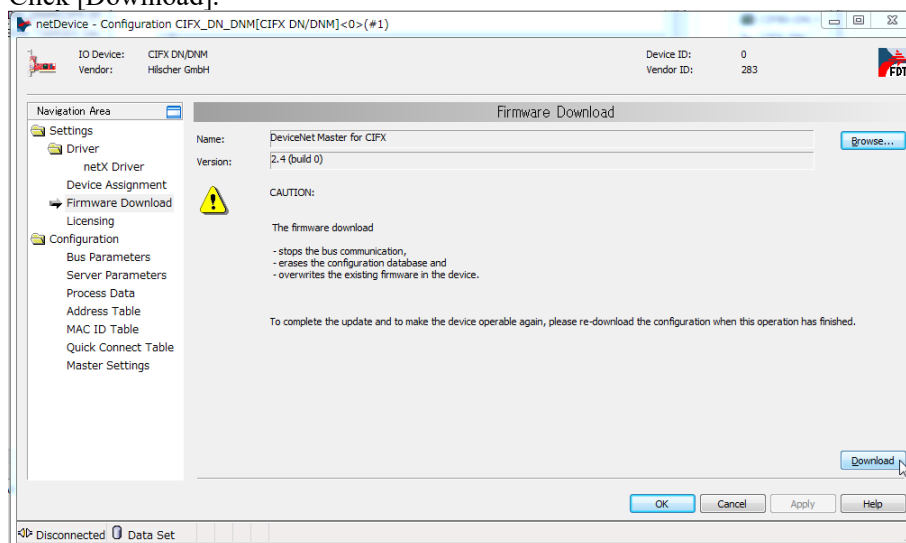

23. Click [Yes].

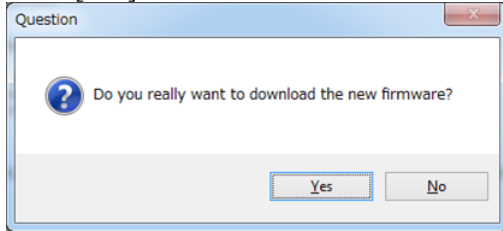

Start the installation of firmware.

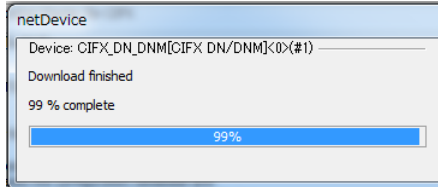

24. Select [Configuration]-[Bus Parameters] tab.
Select [MAC ID] and [Baud Rate] on the master side.
Click [Apply].

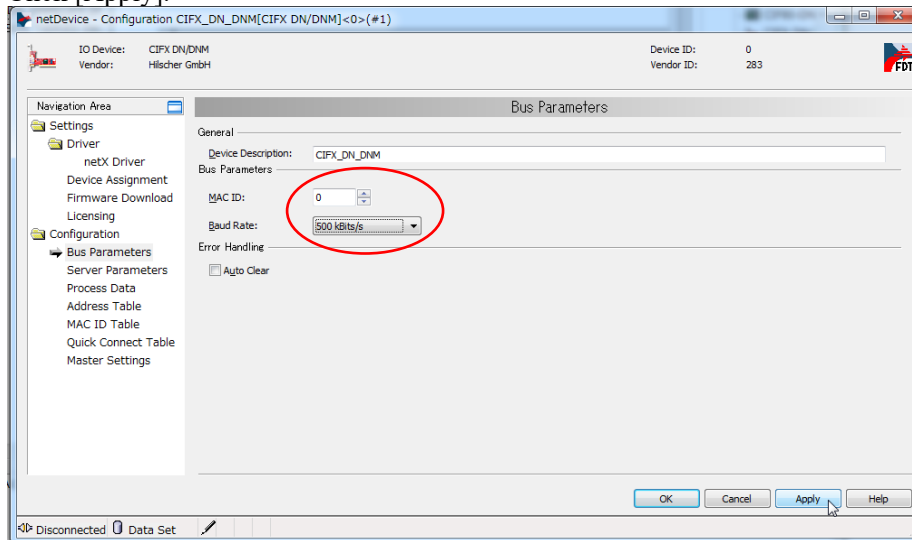

25. Select [Configuration]-[MAC ID Tables] tab.
Enter [MAC ID] on the slave side.
Click [OK].

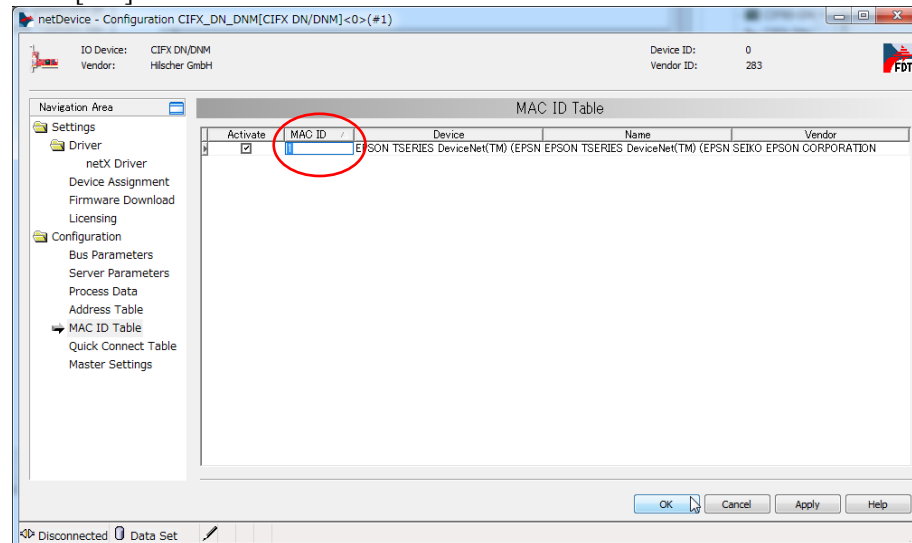

26. Close the [Configuration] dialog box.

Setting on slave side

27. Right-click [netDevice]-[EPSON TSERIES...] icon.
Select [Configuration...].

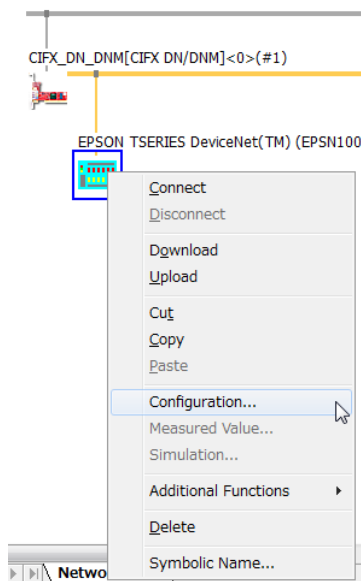

28. The [Configuration] dialog box appears.
29. Select the [Configuration]-[General] tabs.
30. Check the UCMM box and set Group according to the slave device you use.

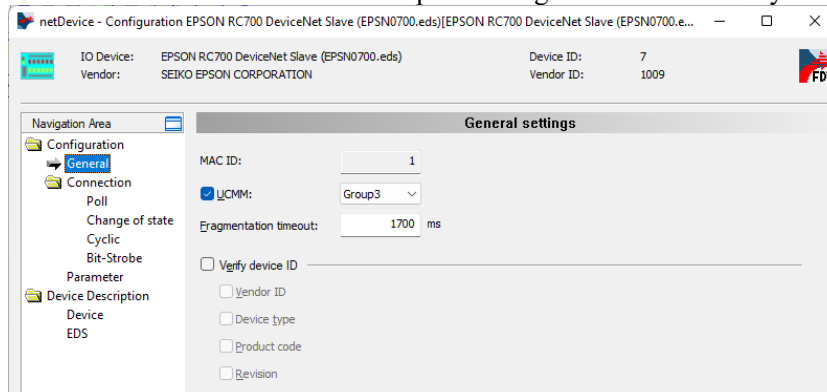

31. Select [Configuration]-[Connection]-[Poll] tab.
32. Enter the settings of the slave side and click [OK].

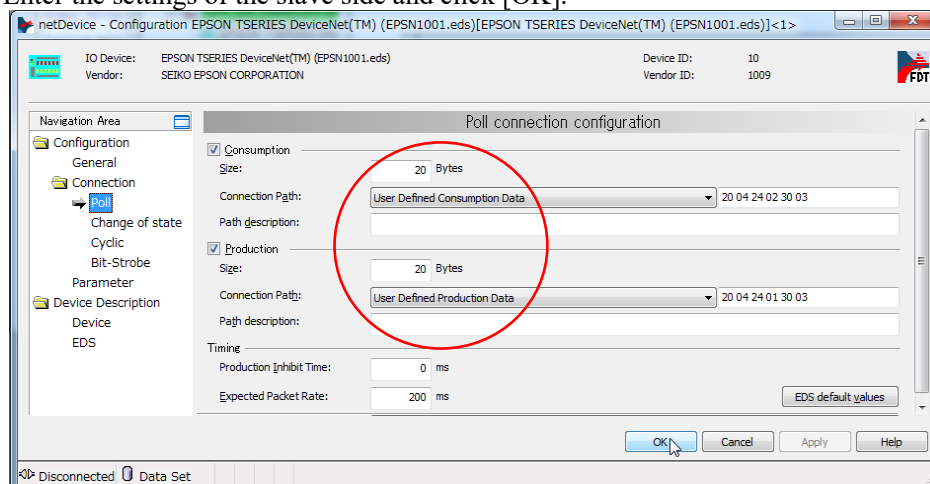

Poll connection configuration

Item	State
Consumption	Checked
Consumption - Size	20
Consumption - Connection Path	User Defined Consumption Data
Production	Checked
Production - Size	20
Production - Connection Path	User Defined Production Data

33. Close the [Configuration] dialog box.

Downloading to master board

34. Right-click [netDevice]-[CIFX_DN_DNM] icon.
Select [Download].

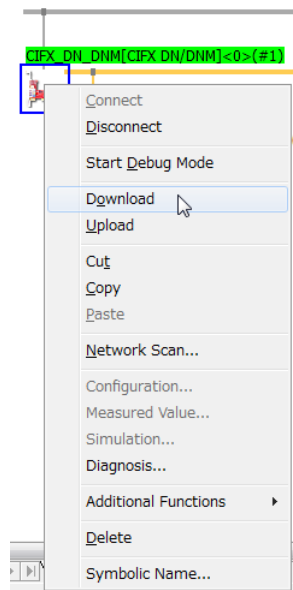

By the above step, “Setting on master side” and “Setting on slave side” are downloaded to the DeviceNet master board.

Diagnosis

35. Right-click [netDevice]-[CIFX_DN_DNM] icon.
Select [Diagnosis...].

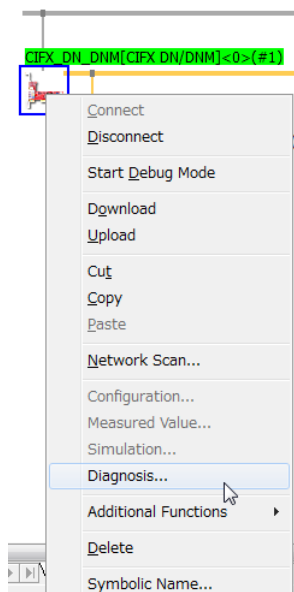

36. The [Diagnosis] dialog box appears.
Select [Diagnosis]-[General Diagnosis].
Confirm that [Device status]-[Communication] turns to green.

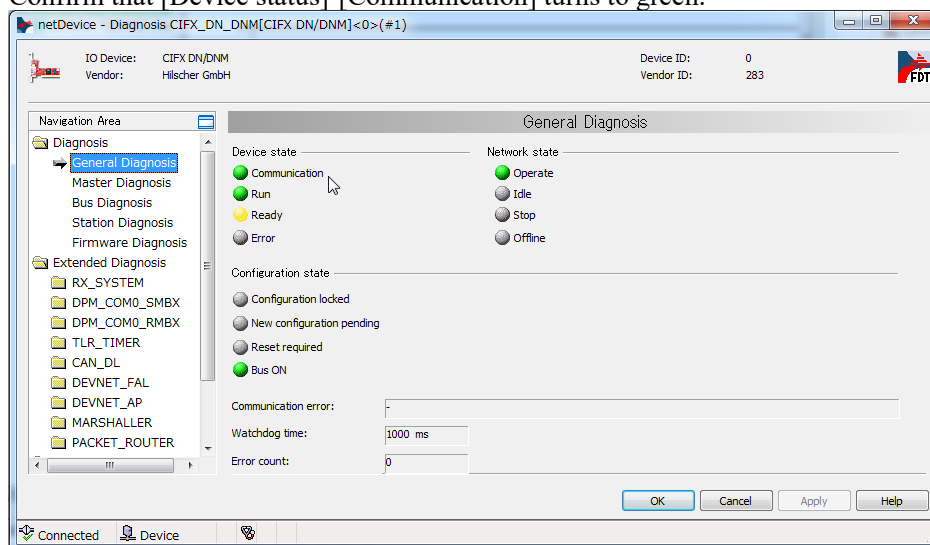

37. Close [Diagnosis] dialog box.

38. Select [File]-[Save].

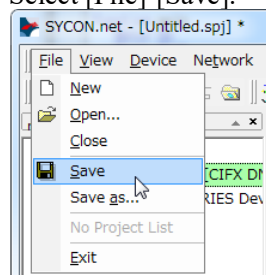

39. The [Save As] dialog box appears.
Enter [File name] and click [Save].
The setting changes are saved.

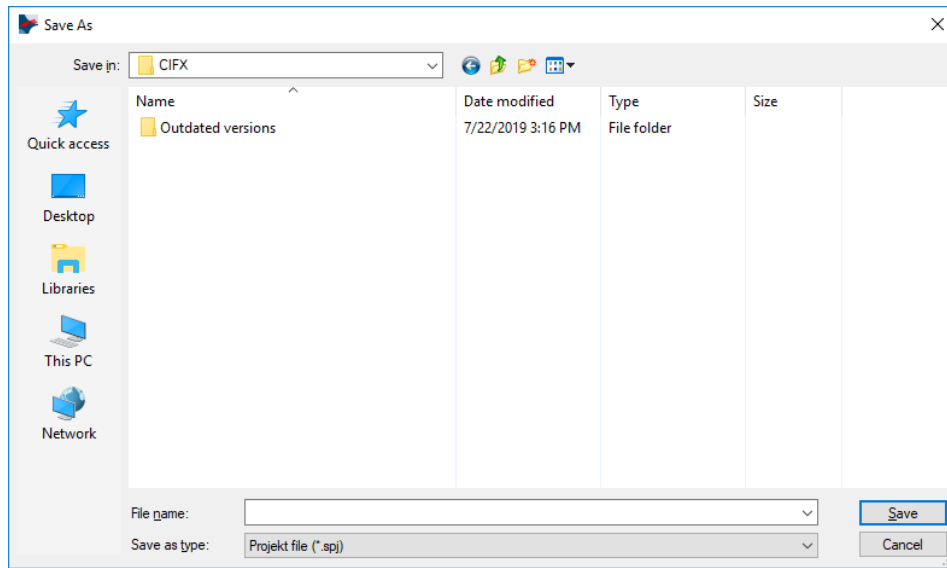

Exporting the configuration file (.csv) for RC+

40. Right-click [netDevice]-[CIFX_DN_DNM] icon.
Click [Additional Functions]-[Export]-[CSV...].

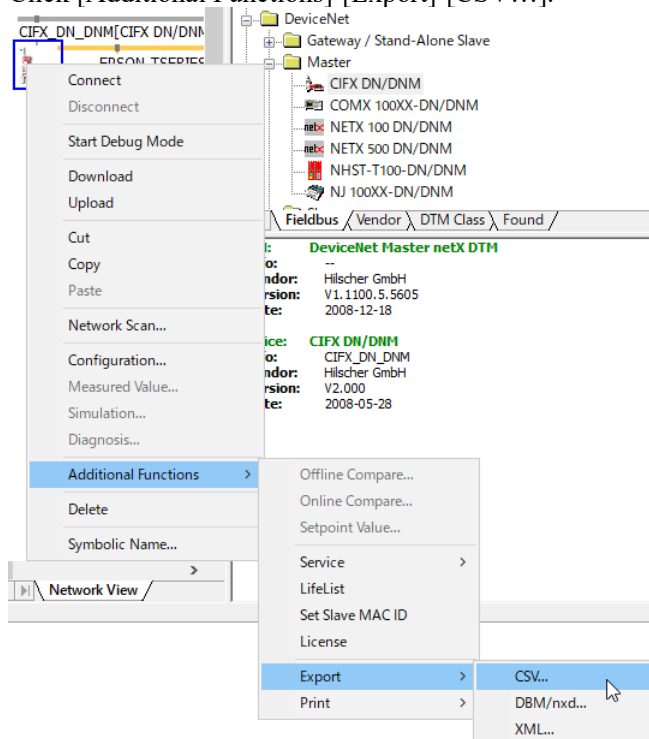

41. Save the CSV file to the file.
Exported CSV file is used in the next *Epson RC+ 8.0 Configuration*.

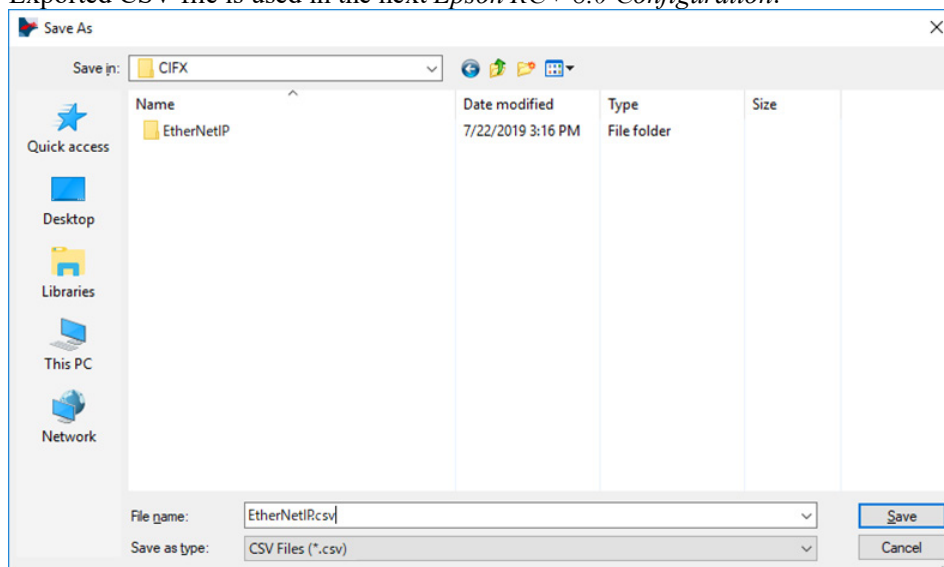

Now, the settings by SYCON.net are complete.
Close SYCON.net.



If there is a problem such as the fieldbus master board is not recognized by Windows, make sure that the combination is described in "Control System Configuration" in the preface of this manual and refer to the following section.

4. Troubleshooting

4.4 How to Disable Fast Startup in Windows

Epson RC+ 8.0 Configuration

To use the Fieldbus master board, the Robot system option setting and Fieldbus master setting should be enabled on the Epson RC+ 8.0.

1. Select [Setup]-[License Configuration] and display the [License Configuration] dialog box.
2. Refer to the *Epson RC+ User's Guide: Installing Controller Licenses* and enable the Fieldbus Master option.
3. When the following message displays, click the [OK] button.

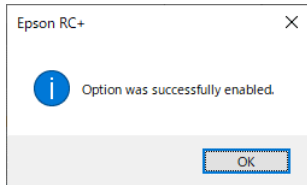

4. Select [Setup]-[System Configuration] and display the [System Configuration] dialog box.
5. Select [Controller]-[Inputs/Outputs]-[Fieldbus Master]-[General].

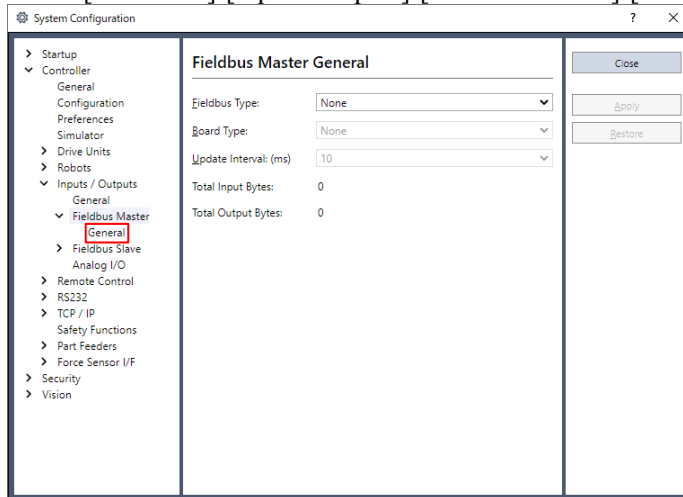

6. Set the following items:
 [Fieldbus Type:] DeviceNet
 [Board Type:] Hilscher
 [Update Interval:] Update cycle for the DeviceNet master I/O

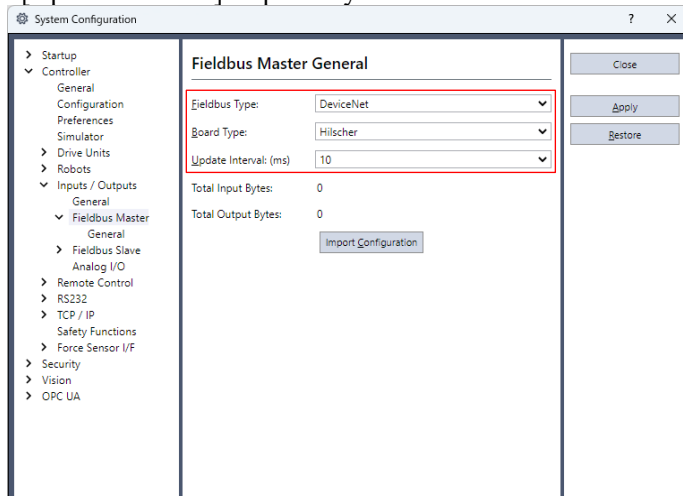

Click [Import Configuration].

7. Select the configuration file (.csv) for RC+.
Click [Open].

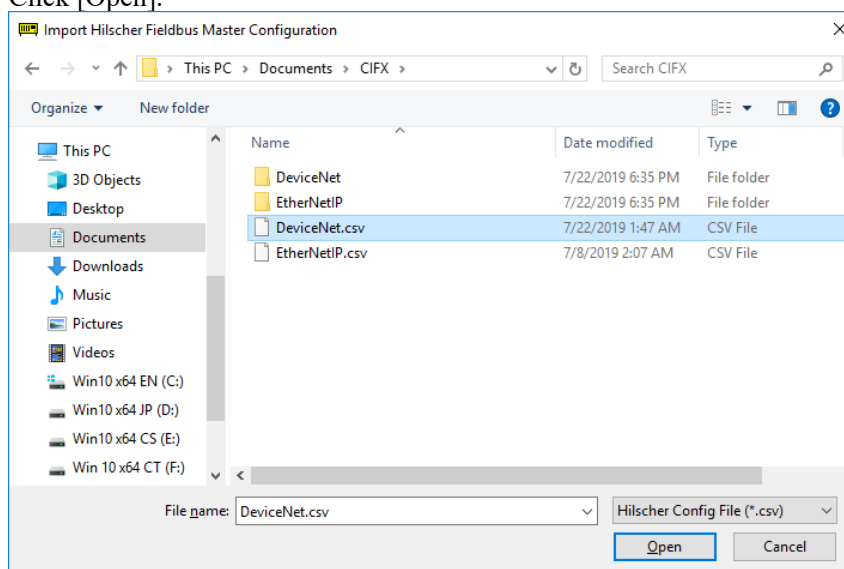

8. Confirm that the configuration file (.csv) for RC+ is imported and click [OK].

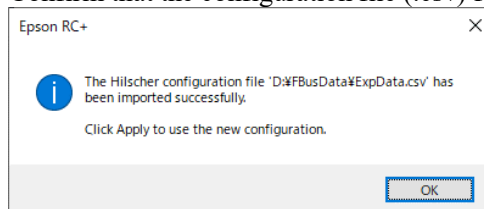

9. Click [Apply]. Confirm that the following items are displayed.

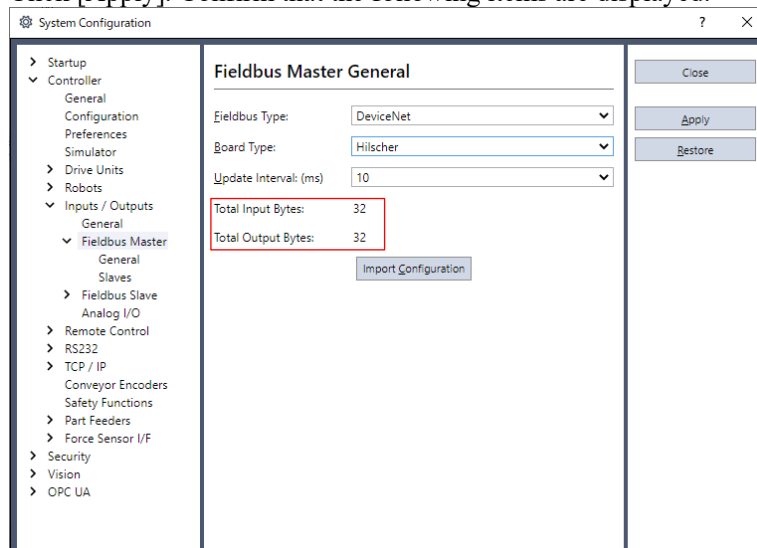

Total Input Bytes : Number of inputs the master controls (Bytes)

Total Output Bytes : Number of outputs the master controls (Bytes)

10. Click [Close].
The following dialog box appears and the Controller automatically starts rebooting.



2.1.5 Installing DeviceNet Slave Board

Appearance

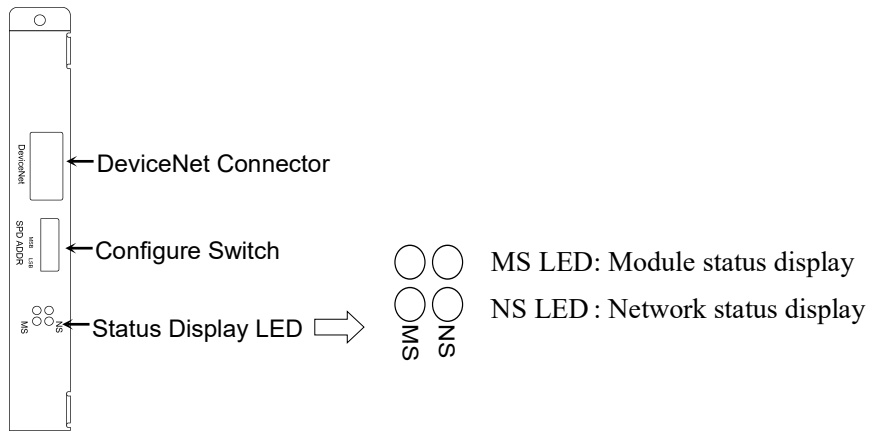

The Fieldbus slave board is configured as follows at shipment.

Board Appearance

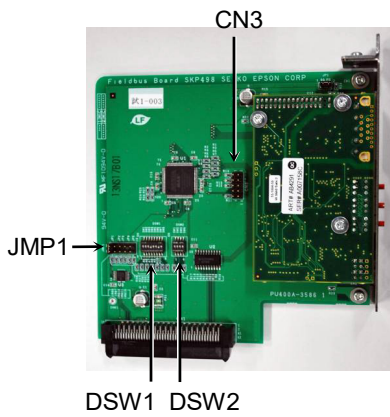

Configuration

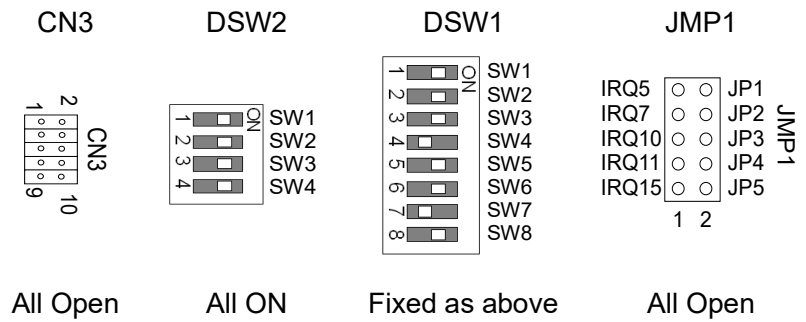

DeviceNet Communication Specifications

Item	Specification			
Name	DeviceNet slave board			
Supported Connection	I/O messaging connection (Polling), UCMM, Explicit message connection, DeviceNet communication protocol			
Baud Rates	125 k / 250 k / 500 k (bps)			
Transfer Distance	Baud Rates	Max. Network Length	Drop Length	Total Drop Line Length
	500 k (bps)	100 m	6 m or under	39 m or under
	250 k (bps)	250 m *	6 m or under	78 m or under
	125 k (bps)	500 m *	6 m or under	156 m or under
Cable	5-wire cable dedicated to DeviceNet (2 wires for signal, 2 wires for power supply, 1 shield wire)			
Communications Power Supply Voltage	24 VDC (supplied from a connector)			
Communication Power Supply Current Consumption	Maximum 30 mA			
Mode	Slave			
Interface	1 DeviceNet port			
Max. Input data size	2048 bits (256 bytes)			
Max. Output data size	2048 bits (256 bytes)			

* When Thin cable is used for trunk line, the maximum network length is 100 m.

LED Description

LED state represents the status of the fieldbus board.

LED state		NS	MS
OFF		Communications power supply OFF Disconnected	Device power supply OFF
GRN	ON	Link OK Online connected	Device operating
	Blinking	Online disconnected	Data size error
RED	ON	Link error	Critical error
	Blinking	Communication time out	Error

Setting Configure Switch



WARNING

- Make sure that the power is turned OFF before installing/removing any boards or connecting/disconnecting any cables. Working with the power ON is extremely hazardous and may result in electrical shock and/or malfunction of equipment.

Set the baud rates between the MAC address of the device and the master by setting the DeviceNet slave board configure switch.

1. Set the MAC address for DeviceNet slave board by setting the configure switch. Make sure that the MAC address is different from the other devices in the network. Refer to the following table for the configuration.

MAC address	Switch					
	sw3 (MSB)	sw4	sw5	sw6	sw7	sw8 (LSB)
0	OFF	OFF	OFF	OFF	OFF	OFF
1	OFF	OFF	OFF	OFF	OFF	ON
2	OFF	OFF	OFF	OFF	ON	OFF
3	OFF	OFF	OFF	OFF	ON	ON
⋮	OFF	OFF	OFF	OFF	OFF	OFF
62	ON	ON	ON	ON	ON	OFF
63 (at shipment)	ON	ON	ON	ON	ON	ON

2. Set the DeviceNet slave baud rate. Check the master configuration and set the same baud rate. Refer to the following table for configuration settings.

Baud Rate	Switch	
	sw1	sw2
125 k	OFF	OFF
250 k	OFF	ON
500 k	ON	OFF
Configuration prohibited	ON	ON

Wiring

DeviceNet connector is a 5-pin open connector. Use the connector attached to the board for wiring.

Terminal name for each pin

Terminal Number	Terminal Name
1	V-
2	CAN L
3	SHELD
4	CAN H
5	V+



NOTE

Prepare the cable for DeviceNet sold in the market as a communication cable. Install terminating resistors at both ends of the network.

Installing a Board



- Make sure that the power is turned OFF before installing/removing any boards or connecting/disconnecting any cables. Working with the power ON is extremely hazardous and may result in electrical shock and/or malfunction of equipment.

Install the board to the dedicated slot on the Robot Controller.

Reference manuals:

RC700 Series Maintenance MANUAL 7.1 Option Board

RC90 Series Maintenance MANUAL 7.1 Option Board

When using RC700-D and RC700-E, please contact the supplier of your region.

Confirmation with Epson RC+ 8.0

When the DeviceNet slave board is installed to the Controller, it is recognized automatically. Confirm whether Epson RC+ 8.0 has recognized the DeviceNet slave board using the following procedure.

1. Select [Setup]-[System Configuration] and display the [System Configuration] dialog box.
2. Select [Controller]-[Inputs / Outputs].

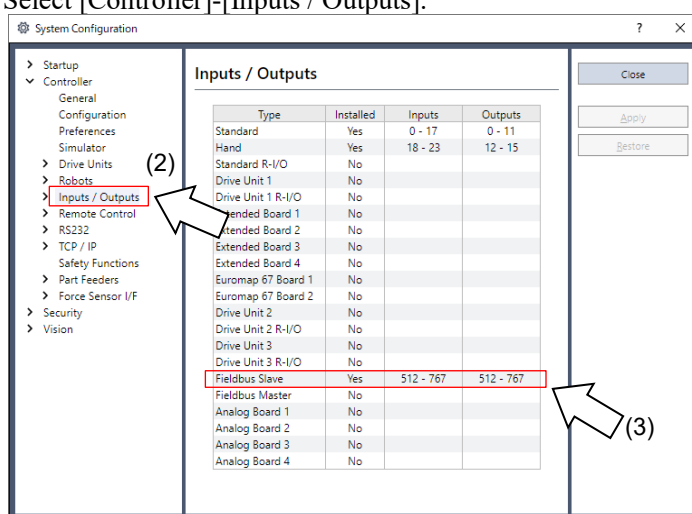

3. Confirm that the following items are displayed in the “Fieldbus Slave”.

Installed : Yes

Inputs : 512-767 (default setting)

Outputs : 512-767 (default setting)

4. Select [Fieldbus Slave]-[General].

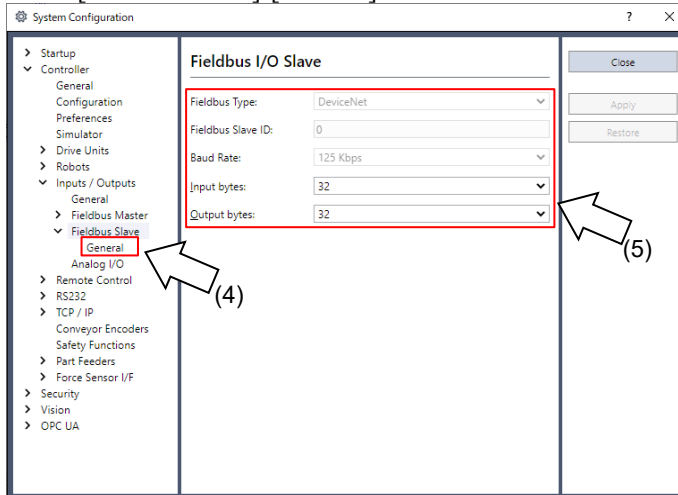

Confirm that the following items are displayed.

- Fieldbus Type : DeviceNet
- Fieldbus Slave ID : (Displays the configure switch MAC address)
- Baud Rate : (Displays the configure switch baud rate)
- Input Bytes : 32 (default setting)
- Output Bytes : 32 (default setting)

5. Click [Close].

Editing of Input / Output Size

You can change the input/output size of DeviceNet slave board if necessary.

1. Select [Setup]-[System Configuration] and display the [System Configuration] dialog box.
2. Select [Controller]-[Inputs / Outputs]-[Fieldbus Slave]-[General].

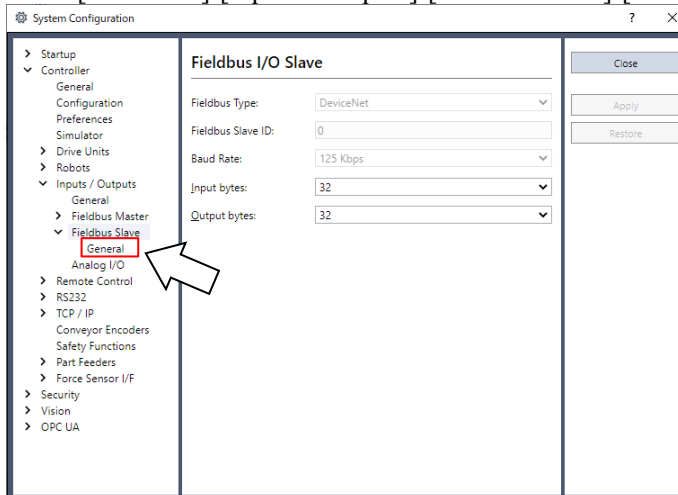

3. Change the settings of [Input Bytes] and [Output Bytes].

In this example, both of them are changed to “20” Bytes.

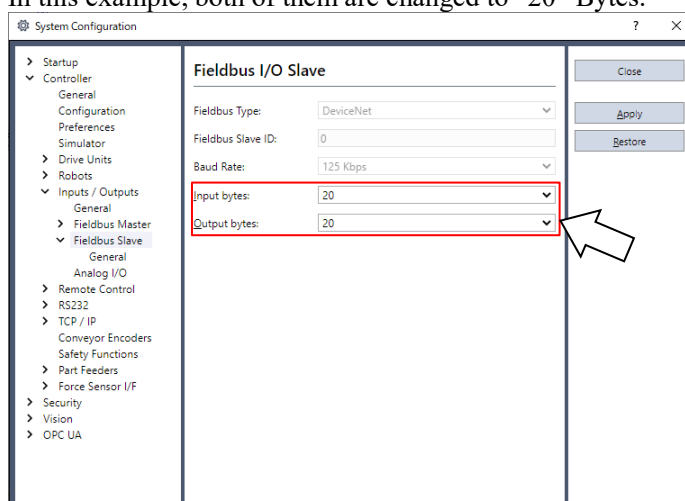

4. Click [Apply].

5. Click [Close].

The following message dialog box appears and the Controller automatically starts rebooting.



6. Select [Setup]-[System Configuration] and display the [System Configuration] dialog box.

7. Select [Controller]-[Inputs / Outputs].

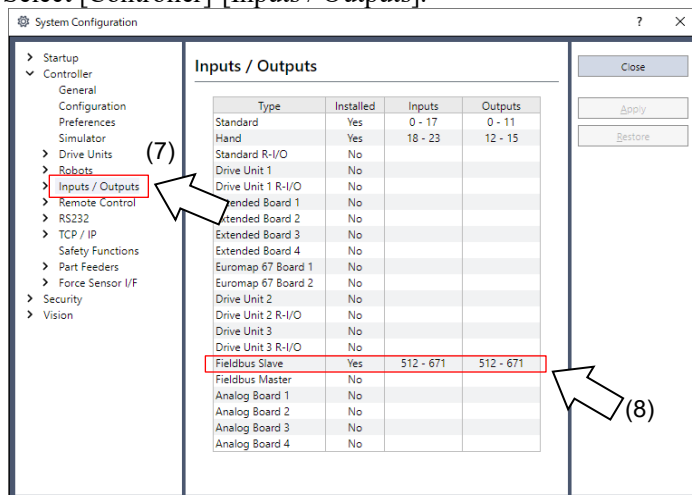

8. Confirm that the following items are displayed in “Fieldbus Slave”.

Inputs : 512 – (512 + Changed number of input (Bits))

Outputs : 512 – (512 + Changed number of output (Bits))

In this example, Input byte is 20 bytes (160 bits) and 512-671 is displayed in Inputs.

Also, Output byte is 20 bytes (160 bits) and 512-671 is displayed in Outputs.

9. Click [Close].

NOTE

When you change the input/output size of DeviceNet slave board, you need to change the input/output size of the slave information registered in the Fieldbus master device.

Use the window below to change the input/output size of the slave information registered in the Fieldbus master device by the applicomIO Console application.

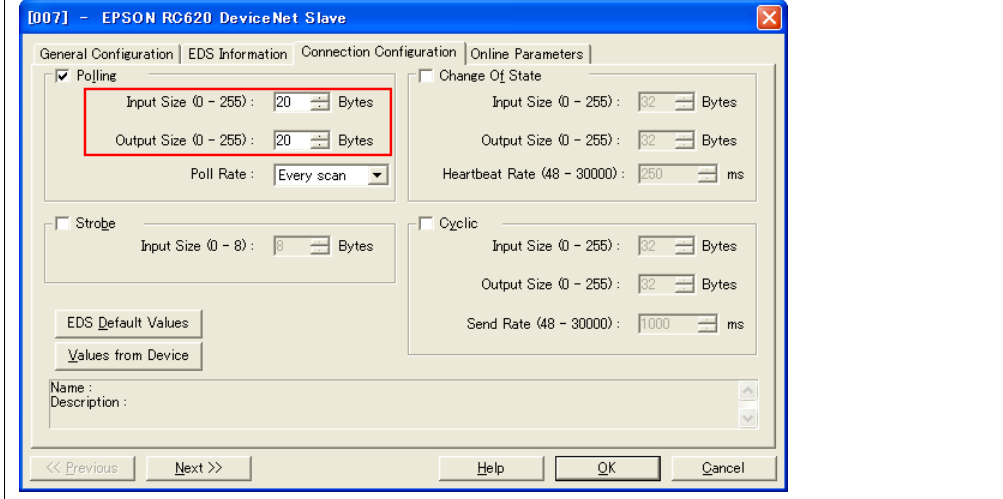

Electronic Information File (EDS file)

An EDS file is supplied for DeviceNet slave board network configuration. The file is located in the following folder where the Epson RC+ 8.0 is installed.

C:\EpsonRC80\Fieldbus\DeviceNet

Compatible list of EDS file

Controller	File name
RC700 series	EPSN0700.eds
RC90 series	EPSN0501.eds

2.1.6 Installing DeviceNet Slave Module



- Make sure that the power is turned OFF before installing/removing any modules or connecting/disconnecting any cables. Working with the power ON is extremely hazardous and may result in electrical shock and/or malfunction of equipment.



- Pay attention to the followings in order to prevent the the DeviceNet connector from coming off.
 1. Use the connectors attached to the module.
 2. Insert the connectors all the way seated.
 3. Fix the cables at proper positions in order not to put a load on the connectors.

Appearance

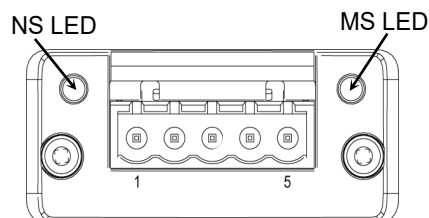

DeviceNet Communication Specifications

Item	Specification			
Name	DeviceNet slave module			
Supported Connection	I/O messaging connection (Polling), UCMM, Explicit message connection, DeviceNet communication protocol			
Baud Rates	125 k / 250 k / 500 k (bps)			
Transfer Distance	Baud Rates	Max. Network Length	Drop Length	Total Drop Line Length
	500 k (bps)	100 m	6 m or under	39 m or under
	250 k (bps)	250 m *	6 m or under	78 m or under
	125 k (bps)	500 m *	6 m or under	156 m or under
Cable	5-wire cable dedicated to DeviceNet (2 wires for signal, 2 wires for power supply, 1 shield wire)			
Communications Power Supply Voltage	24 VDC (supplied from a connector)			
Communication Power Supply Current Consumption	Maximum 30 mA			
Mode	Slave			
Interface	1 DeviceNet port			
Max. Input data size	RC800 series		T/VT series	
	4096 bits (512 bytes)		2048 bits (256 bytes)	
Max. Output data size	RC800 series		T/VT series	
	4096-bit (512 bytes)		2048 bits (256 bytes)	

* When Thin cable is used for trunk line, the maximum network length is 100 m.

LED Description

LED state represents the status of the fieldbus module.

NS: Network Status LED

LED State	Description
Off	Not online / No network power
Green	On-line, one or more connections are established
Flashing Green (1 Hz)	On-line, no connections established
Red	Critical link failure, fatal event
Flashing Red (1 Hz)	One or more connections timed-out
Alternating Red/ Green	Executing self test

MS: Module Status LED

LED State	Description
Off	Not operating
Green	Operating in normal condition
Flashing Green (1 Hz)	Missing, incorrect or incomplete configuration, device needs commissioning.
Red	Unrecoverable Fault(s)
Flashing Red (1 Hz)	Recoverable Fault(s)
Alternating Red/ Green	Executing self test

Setting Configure Switch

The DeviceNet slave module requires no configurations.

All the DeviceNet communication configurations are set by the development software (Epson RC+ 8.0).

Wiring

DeviceNet connector is a 5-pin open connector. Use the connector attached to the module for wiring.

Terminal name for each pin

Terminal Number	Terminal Name	Description
1	V-	Negative bus supply voltage (DeviceNet bus power)
2	CAN L	CAN low bus line
3	SHELD	Cable shield
4	CAN H	CAN high bus line
5	V+	Positive bus supply voltage (DeviceNet bus power)



Prepare the cable for DeviceNet sold in the market as a communication cable. Install terminating resistors at both ends of the network.

Installing Module



- Make sure that the power is turned OFF before installing/removing any modules or connecting/disconnecting any cables. Working with the power ON is extremely hazardous and may result in electrical shock and/or malfunction of equipment.

Install the module to the dedicated slot on the Controller.

Reference: Manipulator manual *Setup & Operation 17. Fieldbus I/O*

Reference manuals:

T series MAINTENANCE MANUAL 14.6 Fieldbus I/O

T-B series MAINTENANCE MANUAL 14.5 Fieldbus I/O

VT series MAINTENANCE MANUAL 18.7 Fieldbus I/O

RC800 series Service Manual 4.1.3 Fieldbus I/O Module

Confirmation with Epson RC+ 8.0

When the DeviceNet slave module is installed to the Controller, it is recognized automatically. Confirm whether Epson RC+ 8.0 has recognized the DeviceNet module using the following procedure.

1. Select [Setup]-[System Configuration] and display the [System Configuration] dialog box.
2. Select [Controller]-[Inputs / Outputs].

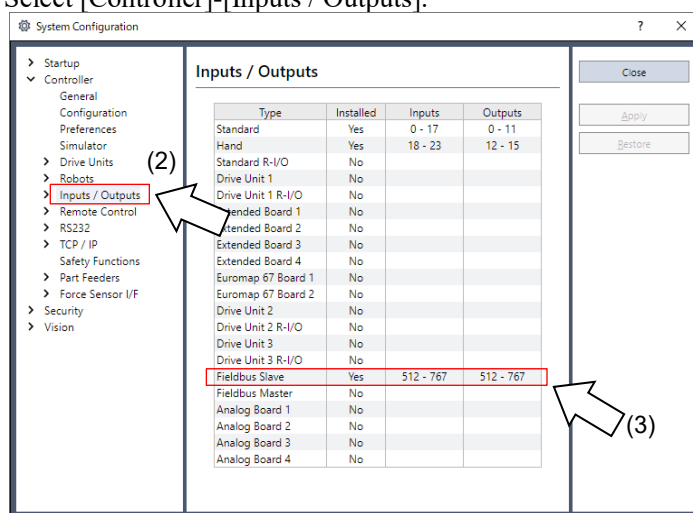

3. Confirm that the following items are displayed in the Fieldbus slave.

Installed : Yes
 Inputs : 512-767 (default setting)
 Outputs : 512-767 (default setting)

4. Select [Fieldbus Slave]-[General].

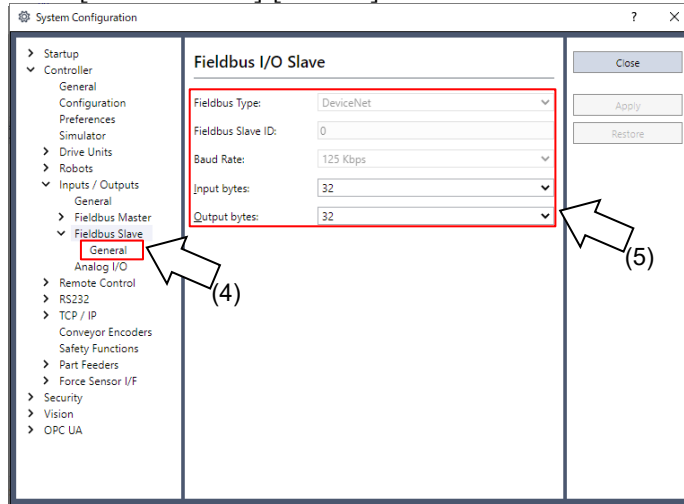

5. Confirm that the following items are displayed.

- Fieldbus Type : DeviceNet
- Node Address : Configure switch Node address
- Baud Rate : Configure switch baud rate
- Input Bytes : 32 (default setting)
- Output Bytes : 32 (default setting)

6. Click [Close].

Editing of Configuration

You can change the configuration of DeviceNet slave module if necessary.

1. Select [Setup]-[System Configuration] and display the [System Configuration] dialog box.
2. Select [Controller]-[Inputs / Outputs]-[Fieldbus Slave]-[General].

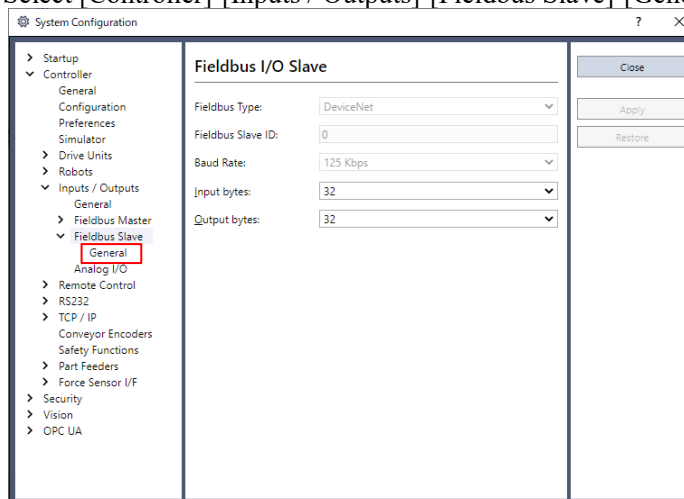

3. Set the Node address.
Confirm that the Node address is different from the other devices in the network.
4. Set the baud rate.
Check the master configuration and set the same baud rate.
5. Change the settings of [Input Bytes] and [Output Bytes].

6. Click [Apply].

7. Click [Close].

The following dialog box appears and the Controller automatically starts rebooting.



8. Select [Setup]-[System Configuration] and display the [System Configuration] dialog box.

9. Select [Controller]-[Inputs / Outputs].

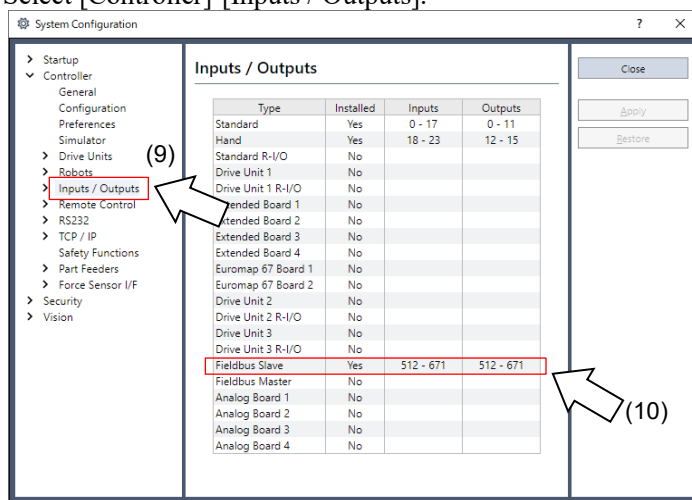

10. Confirm that the following items are displayed in “Fieldbus Slave”.

Inputs :512 – (512 + Changed number of input (Bits))

Outputs :512 – (512 + Changed number of output (Bits))

In this example, Input byte is 20 bytes (160 bits) and 512-671 is displayed in Inputs.

Also, Output byte is 20 bytes (160 bits) and 512-671 is displayed in Outputs.

11. Click [Close].

NOTE

When you change the input/output size of DeviceNet slave module, you need to change the input/output size of the slave information registered in the Fieldbus master device.

Use the window below to change the input/output size of the slave information registered in the Fieldbus master device by the applicomIO Console application.

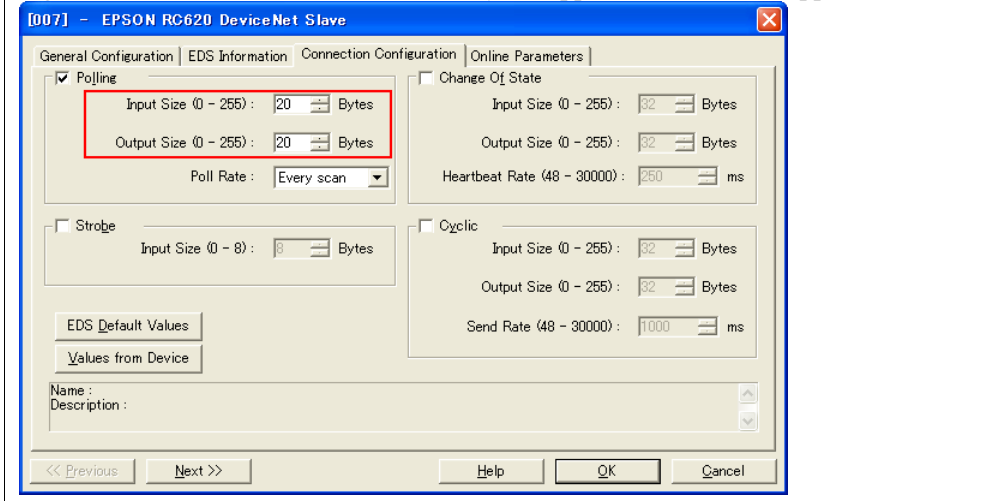

Electronic Information File (EDS file)

An EDS file is supplied for DeviceNet slave module network configuration. The file is located in the following folder where the Epson RC+ 8.0 is installed.

C:\EpsonRC80\Fieldbus\DeviceNet

Compatible list of EDS file

Controller	File name
RC800 series	EPSN1200.eds
T/VT series	EPSN1001.eds

2.2 PROFIBUS-DP



- Make sure that the power is turned OFF before installing/removing any boards or connecting/disconnecting any cables. Installing/removing any boards or connecting/disconnecting any cables with the power ON is extremely hazardous and may result in electric shock and/or malfunction of equipment.

2.2.1 How to Setup a PROFIBUS DP Network

The following is a basic procedure for setting up a PROFIBUS DP network:

1. Choose station layout and pathway in your network.
For details, refer to the following section *2.2.2 PROFIBUS DP Network Construction*.
2. Choose the baud rate.
Choose the baud rate based on the network length. Select the fastest baud rate allowed for the length. Increasing network load due to slow baud rate may cause trouble including communication failure.
3. Lay cables.
For details, refer to the following section *2.2.2 PROFIBUS DP Network Construction*.
4. Configure stations.
For details, refer to respective manuals of your desired stations.
5. Turn ON the stations.
6. Install the PROFIBUS-DP board into the Controller.
Refer to the following for the fieldbus type you have.
 - When installing a PROFIBUS-DP master board:
Refer to *2.2.3 Installing a PROFIBUS-DP Master Board Manufactured by molex*.
 - When installing a PROFIBUS-DP slave board:
Refer to *2.2.4 Installing a PROFIBUS-DP Slave Board*.
 - When installing a PROFIBUS-DP Slave Module:
Refer to *2.2.5 Installing a PROFIBUS-DP Slave Module*
7. Operate the PROFIBUS DP network.

2.2.2 PROFIBUS DP Network Construction

Network Configuration

PROFIBUS DP network is configured as shown in the following figure.

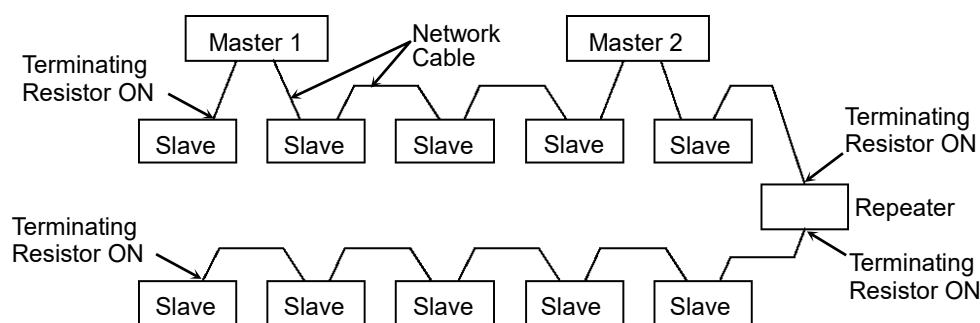

Station

There are four types of stations (devices):

- Master :Controls a network and gathers its slaves.
- Slave :External I/O and other devices/
Slave outputs data as a response to a master’s output order and informs the master of its input status.
- Repeater :Repeater is necessary for a network with more than 32 slaves to separate network segments.
- Configurator :Used only for network installation. It configures a scan list of the slaves on the master device.

You can install masters anywhere in the network. You can connect up to 126 stations including server and repeater in the network. However, it is recommended to keep one device for the engineering device.

Network Cable

The PROFIBUS cable can be used as a network cable. There are four types (A, B, C, and D) of PROFIBUS cables. Normally, cable type A is used for PROFIBUS DP network. The cable type A specifications are shown in the table below.

Item	Specification
Impedance	135 to 165 Ω
Capacity	< 30 pf/m
Loop resistance	110 Ω/km
Wire diameter	0.64 mm
Core cross-section	> 0.34 mm ²

It is recommended to use a 9-pin D-Sub connector for protecting rating IP 20. For IP 65/67, M12 connector (IEC 947-5-2 compliant), Han-Bird connector (DESINA compliant), and Siemens hybrid connector are available.

Pin assignment (9-pin D-Sub)

Pin No.	Signal	Assignment
1	Shield	Shield / Protective ground
2	M24	Ground of output voltage (24 V)
3	RxD/TxD-P	Data line B
4	CNTR-P	Repeater control signal (directional control)
5	DGND	Communications power supply (5 V)
6	VP	Supply voltage to terminating resistor (P5V)
7	P24	Output voltage (24 V)
8	RxD/TxD-N	Data line A
9	CNTR-N	Repeater control signal (directional control)

Use pins 2 and 7 for connecting a maintenance device without any power supply.

The following figure illustrates wiring sample.

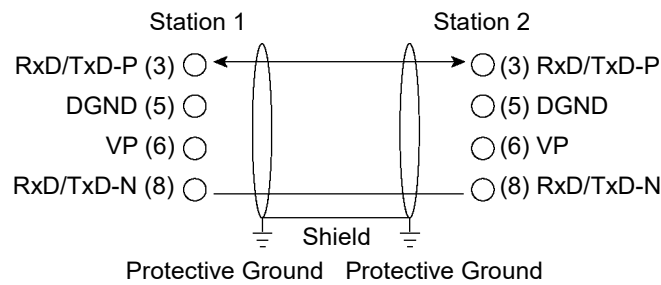

PROFIBUS cables are produced by a variety of manufacturers. For details of the PROFIBUS cables, see PROFIBUS International's website (<https://www.profibus.com/>).

Terminating Resistor

To reduce reflections of communication signal, terminating resistors should be attached on both ends of each segment. Attach the terminating resistor as shown below.

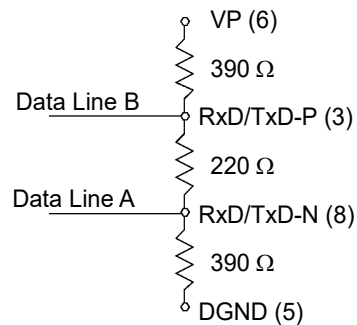

Some commercially available PROFIBUS 9-pin D-Sub connectors have functions of terminating resistor and they can enable/disable the terminating resistors. (Example: Woodhead MA9D00-32)

Molded terminating resistors with connector that can be attached to environment-resistant M12 connector are also available.

Baud Rate and Maximum Cable Length

Available baud rates are 9.6 kbps, 19.2 kbps, 93.75 kbps, 187.5 kbps, 500 kbps, 1500 kbps, 3 Mbps, 6 Mbps, and 12 Mbps.

PROFIBUS DP requires approximately 1ms at 12 Mbps for transmission of 512 bits input data and 512 bits output data distributed over 32 stations. The following figure shows typical PROFIBUS DP transmission times depending on the number of stations and baud rate.

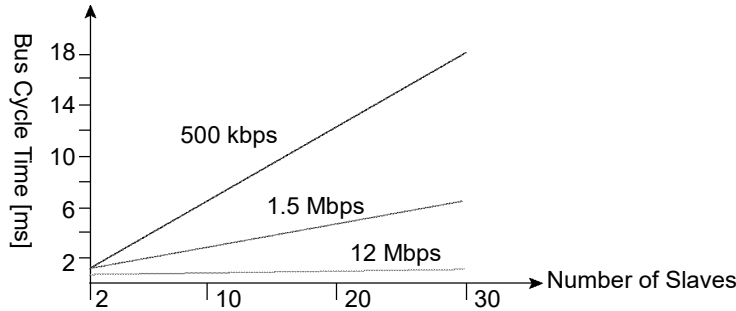

The maximum cable length is restricted by the baud rate.

Baud Rate	Maximum Cable Length
12 Mbps	100 m
6 Mbps	100 m
3 Mbps	100 m
1500 kbps	200 m
500 kbps	400 m
187.5 kbps	1000 m
93.75 kbps	1200 m
19.2 kbps	1200 m
9.6 kbps	1200 m

Multi-Master Configuration

PROFIBUS DP allows you to install multiple masters in a single physical network.

All slave devices in the network can be accessed by different masters. Only one master on the network can be used for device configuration.

The following figure illustrates the communication procedure for a multi-master configuration.

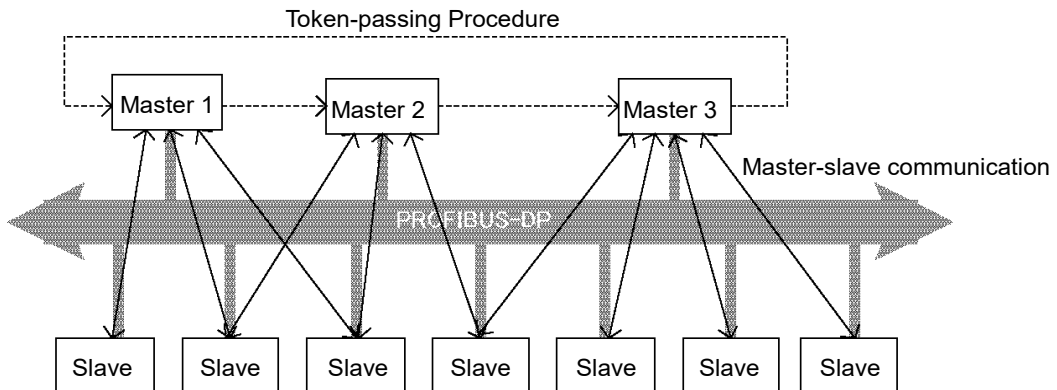

When the master receives the logic token, it inquires data from its slaves. After all communications are completed, the master passes the token to another master. In this way, the master can only communicate with its slaves while it is holding the token. The slaves respond to only the inquiry from the master. No slave can output any messages.

Modification and Installation of Communication Cables

The following procedure explains how to modify and install a Woodhead 9-pin D-Sub connector (MA9D00-32).

Follow the steps described below to modify communication cables and connect them to the connector.

 CAUTION	<p>■ Be careful not to injure your hands or fingers on any sharp blades or tools used to modify the cable.</p> <p>Use appropriate blades and/or other tools to modify the cable. Using inappropriate blades and/or other tools may result in bodily injury and/or equipment damage.</p>
---	---

- Strip approx. 47.5 mm of the cable covering with extra care so that you do not scratch on braided shield underneath.

Do not strip the cable covering more than necessary. Excess stripping may cause short-circuit and/or make the cable more sensitive to noise.

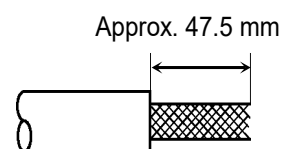

- Carefully expand meshes of the braided shield and fold back the shield over the cable covering. Cut off the shield at approx. 10 mm from the stripped side of the cable covering.

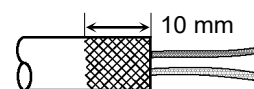

- Strip the covering of the signal wire as shown in the figure.

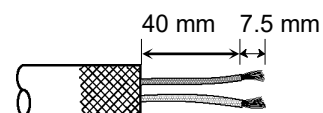

- Insert the signal wires into the terminal block on the connector and secure the signal wires. Carefully connect the same signal wire to the same terminal on both ends. To prevent faulty wiring, make a rule of connection. For instance, connect the green signal wire to the A1/A2 terminal and the red signal wire to the B1/B2 terminal.

2.2.3 Installing PROFIBUS-DP Master Board Manufactured by molex

Appearance

Part names and functions of the PROFIBUS-DP master board manufactured by molex are shown in the following figure. For details on the status display LEDs, refer to 4. *Trouble shooting* in this manual.

PCU-DPIO

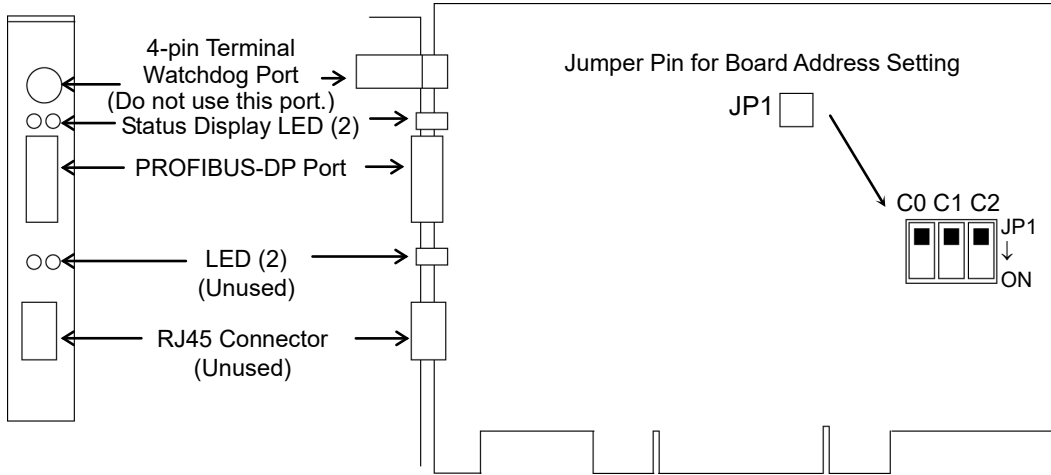

Specifications

Item	Specification
Part Number	PROFIBUS-DP master board manufactured by molex
Modes	Master
Baud Rates	9.6, 19.2, 93.75, 187.5, 500, 1500, 3000, 6000, 12000 kbps
Interface	1 PROFIBUS port (EN 50 170)
Output Current Capacity	Maximum 150mA
Supported Devices	All DP Devices
Maximum Stations	126 (32 per segment)
GDS Support	Yes
PROFIBUS DP Class 1	Yes
PROFIBUS DP Class 2	Yes
Max. Input Data Size	1024 bits (128 bytes)
Max. Output Data Size	1024 bits (128 bytes)
Automatic Detection	Yes. Devices can be detected automatically.

Modes

PROFIBUS-DP master board manufactured by molex has two motion modes; Master mode and Slave mode. However, do not select the Slave mode.

Master Mode

There are two types of PROFIBUS DP master: DPM1 and DPM2. DPM1 (DP Master Class 1) gathers and controls all stations in one PROFIBUS DP network. DPM2 (DP master Class 2) operates network configurations, network maintenance, and diagnosis.

PROFIBUS DP master can control up to 126 stations (max. 128 bytes) in one network.

PLC is typically configured as a master and controls all devices in factory automation system, but Epson RC+ is also capable of being a master.

PROFIBUS DP network configuration is specified by the configuration management software. This software is normally provided by a master device manufacturer. The configuration management software determines parameters for each slave device via an Electronic Data Sheet (GSD).

The connection type is token passing procedure and master-slave communication. The token passing procedure is applied to the PROFIBUS DP network with more than two master devices to transfer network control between masters. The master-slave communication is applied to the communication between the master device with network control and its slave devices.

Available baud rates are 9.6 kbps, 19.2 kbps, 93.75 kbps, 187.5 kbps, 500 kbps, 1500 kbps, 3 Mbps, 6 Mbps, and 12 Mbps.

For the instruction of configuration, refer to the section *Master Mode*.

Installing Software

Before installing the PROFIBUS-DP master board manufactured by molex to the PC with Epson RC+ 8.0 installed, you must install the applicomIO Console application and drivers according to the type of board you are using.

1. Insert the applicomIO Console CD-ROM to the PC with Epson RC+ 8.0 installed.
2. The following dialog box appears. Select “Run setup.exe”.

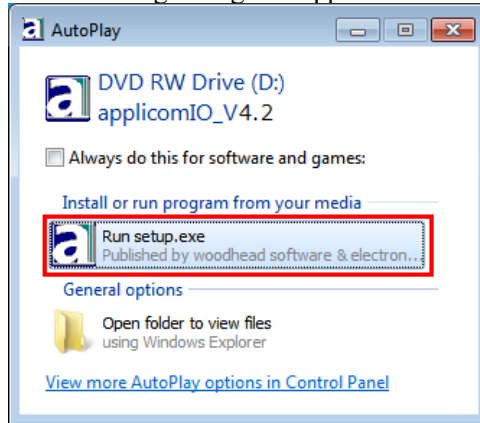

3. The [Summary] dialog box appears. Select “Product Installation”.

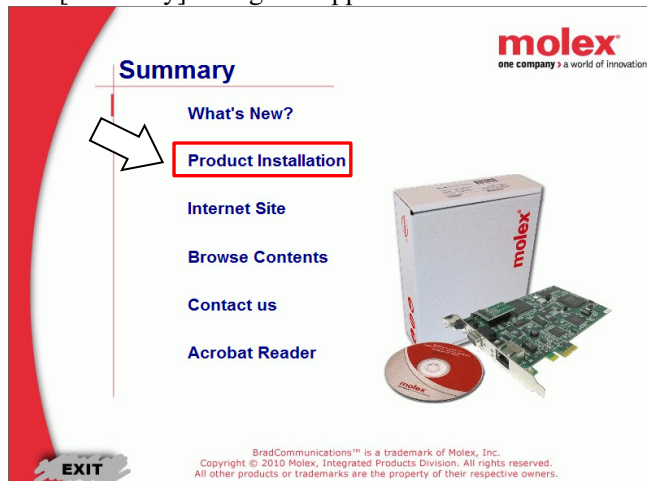

4. The [Installation] dialog box appears. Select “applicomIO”.

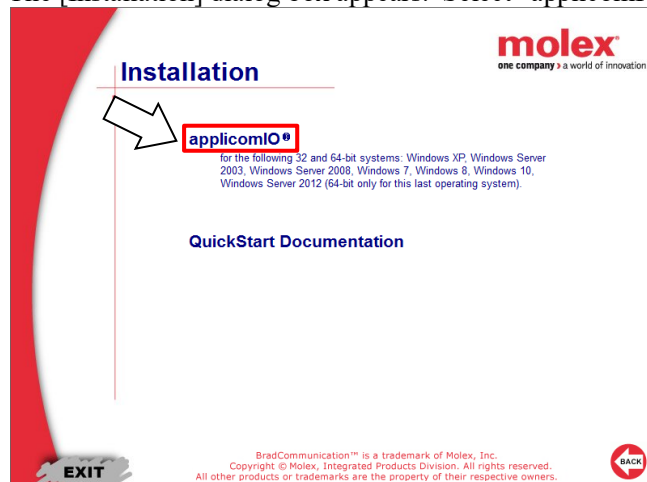

5. If the Microsoft.NET Framework 4.0 is not installed, following dialog box appears. Click [Install].

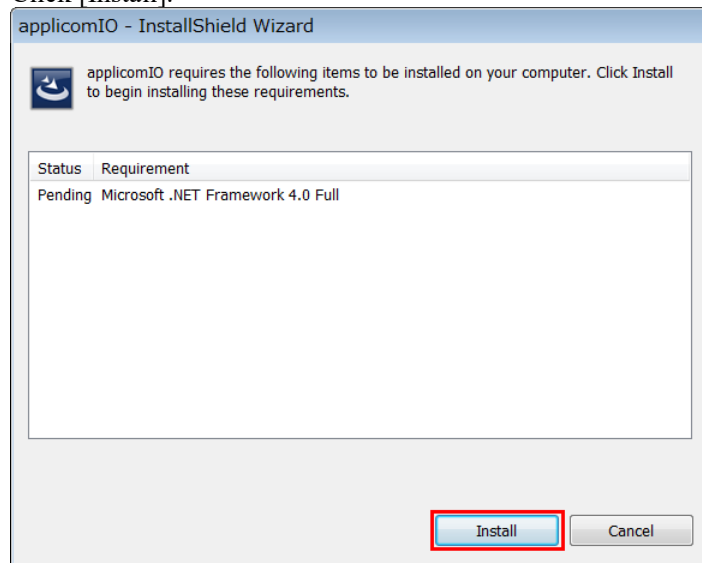

6. The applicomIO Console application installer starts up and the [Welcome to the InstallShield Wizard for applicomIO] dialog box appears. Click [Next].

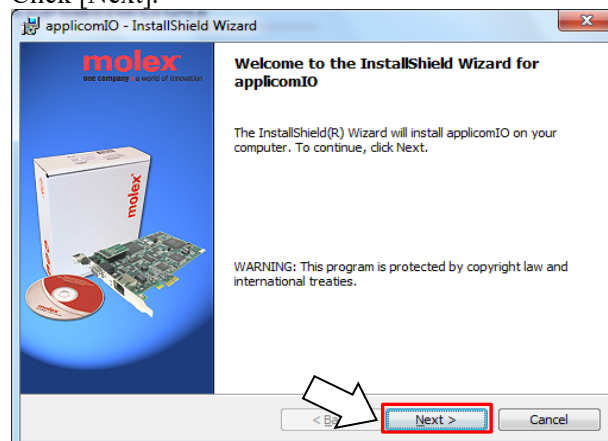

7. The [License Agreement] dialog box appears. Read the software license agreement and click [Next].

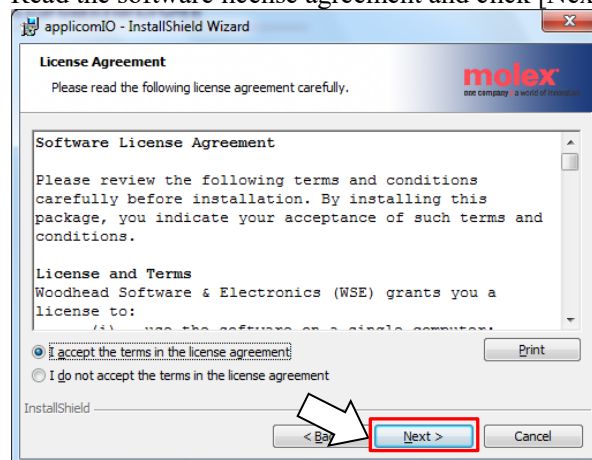

- 8. The [Customer Information] dialog box appears. Register the user information. Enter the User Name and Organization.

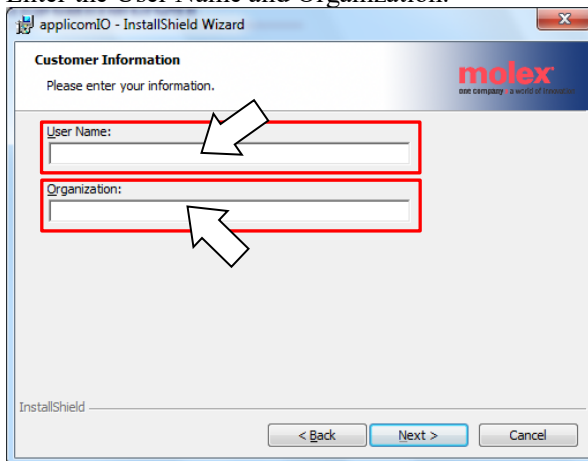

- 9. The [Destination Folder] dialog box appears. Specify the installation folder for the applicomIO console application. The default specifies here:
C:\Program Files(x86)\BradCommunications\applicomIO\4.2
If you agree to the default installation folder, click [Next].

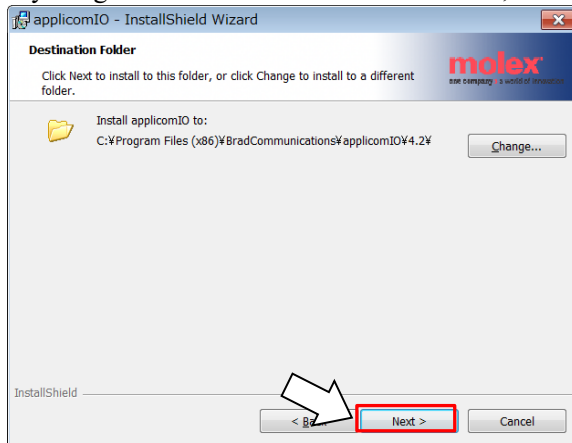

- 10. The [Ready to Install the Program] dialog box appears. Click [Install].

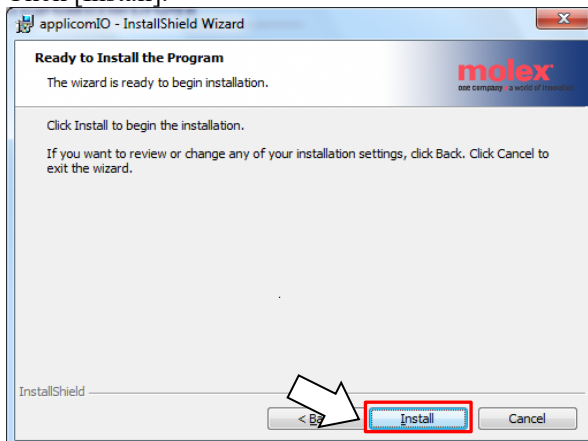

11. Installation of applicomIO Console application starts.
After the installation completes, the [InstallShield Wizard Completed] dialog box appears.
Click [Finish].

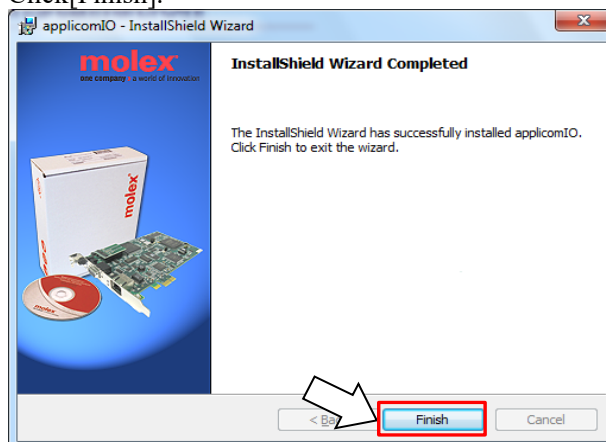

12. The message prompting you to reboot your PC appears.
Select [Yes] and reboot the PC.

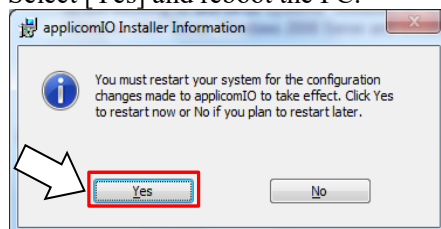

13. Refer to the next section *Installing a Board* and install the PROFIBUS-DP master board manufactured by molex.

Installing a Board



■ Make sure that the power is turned OFF before installing/removing any boards or connecting/disconnecting any cables. Working with the power ON is extremely hazardous and may result in electrical shock and/or malfunction of equipment.

1. Configure the board address dip switch (JP1) on PROFIBUS-DP master board manufactured by molex.
You can install one Fieldbus master board to the PC with Epson RC+ 8.0 installed. The board number should be “1”.

Refer to the following table for JP1 configuration.

Board No. \ Switch	C0	C1	C2
1	OFF	OFF	OFF

2. Install the PROFIBUS-DP master board manufactured by molex to the PCI bus of the PC with Epson RC+ 8.0 installed. Installation methods of the PROFIBUS-DP master board manufactured by molex to the PCI bus and how to open the cover differ depending on the type of PC. Refer to the manuals of each PC on how to install the board to the PCI bus.
3. Connect the PROFIBUS-DP master board manufactured by molex with the PROFIBUS-DP network.
4. Start up the PC.
5. Open the [applicomIO Console] installation folder and start the [applicomIO Console] application.

Following is specified for [applicomIO Console] installation folder as default.

C:\Program Files(x86)\BradCommunications\applicomIO\4.2



consoleio.exe

6. The [Add New Board] dialog box appears. Add the PROFIBUS-DP master board manufactured by molex.
Click [Add Board].

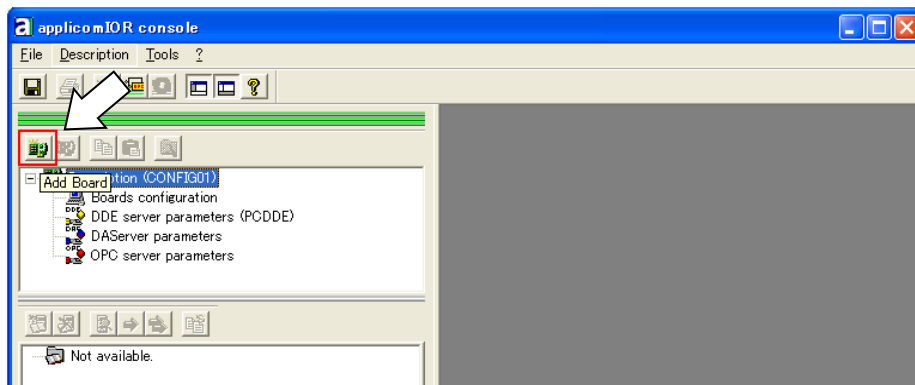

7. The [Add New Board] dialog box appears. Confirm that “PCU-DP2IO” is displayed in [Board to Add]-[Board Type] and click [OK].

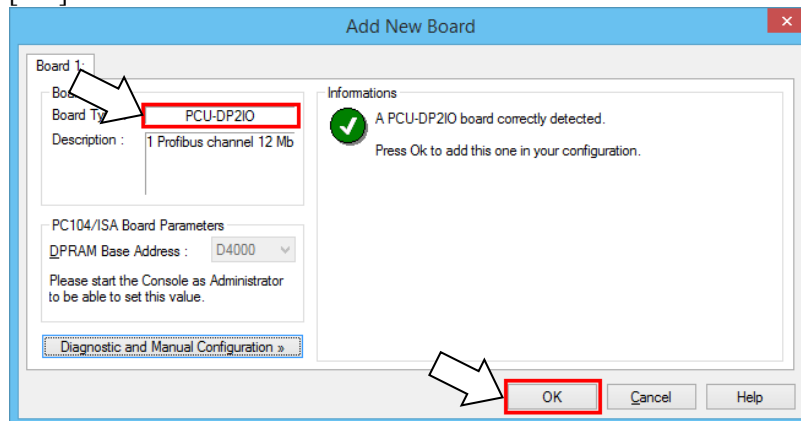

If the board cannot be detected, the following dialog box appears. Make sure that the board is correctly inserted.

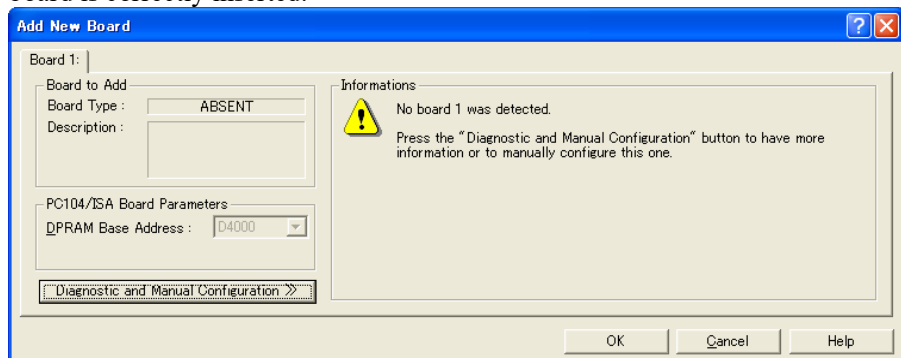

NOTE When a PCI interface board is not detected or a similar problem occurs, refer to the followings to disable the PCI Express Native setting.

4. Troubleshooting

4.6 Disabling the PCI Express Native Setting

8. When you finish adding the PROFIBUS-DP master board manufactured by molex to the applicomIO Console application, reboot the PC.

8-1 Close the applicomIO Console application.

When closing the applicomIO Console application, the following message box appears. Click [Yes].

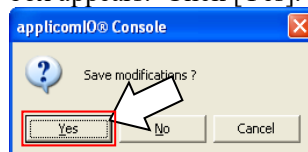

8-2 The following dialog box appears. Click [OK].

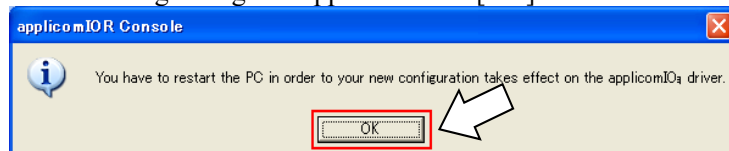

8-3 Reboot the Windows.

9. After the PC is rebooted, refer to the next section *Master Mode* and continue the step.

Master Mode

1. Check that the PROFIBUS-DP master board manufactured by molex is connected to the PROFIBUS-DP network.
2. Start the “applicomIO Console” application.

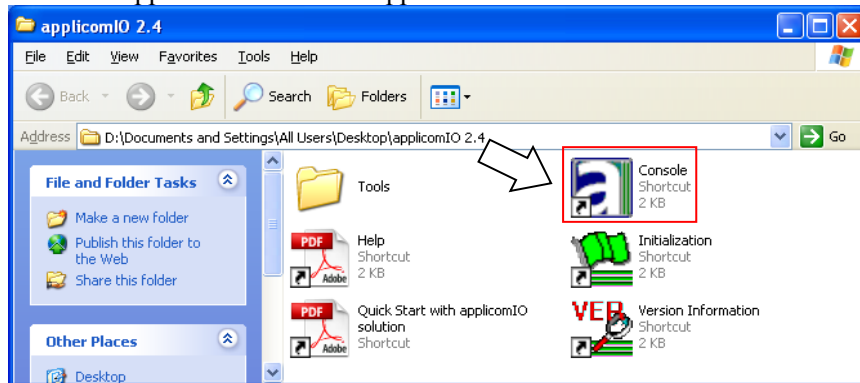

3. The [applicomIOR console] dialog box appears. Register the device information (GSD file) that is necessary for the network setup.

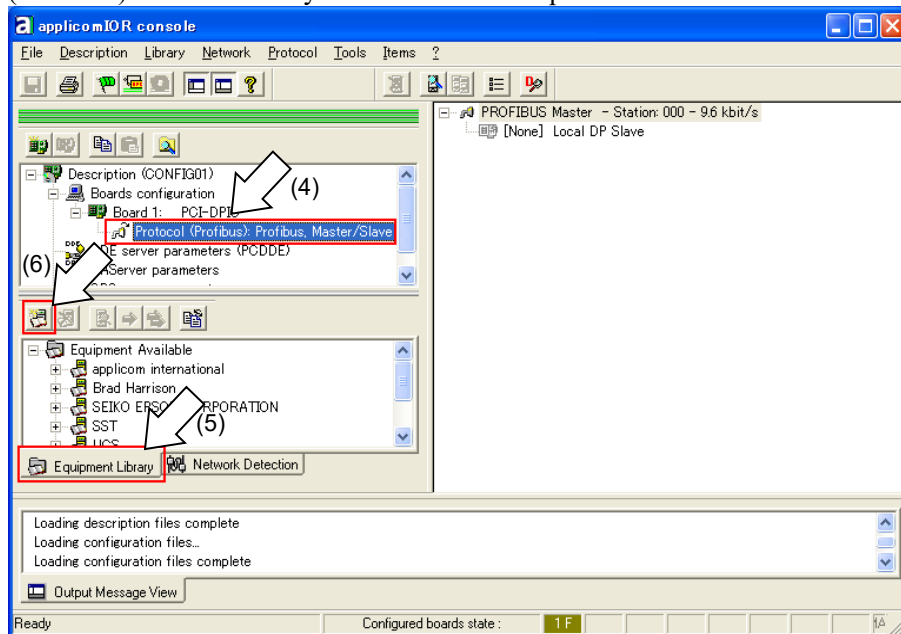

4. Select [Protocol].
5. Select the [Equipment Library] tab.
6. Click [Add].

7. The [GSD Management] dialog box appears. Register the GSD file that is supplied from the device manufacturer in the Robot system.

Click [Next].



8. Following dialog box appears. Specify the folder in which the GSD file is stored. Select [Add all the GSD from the Directory].

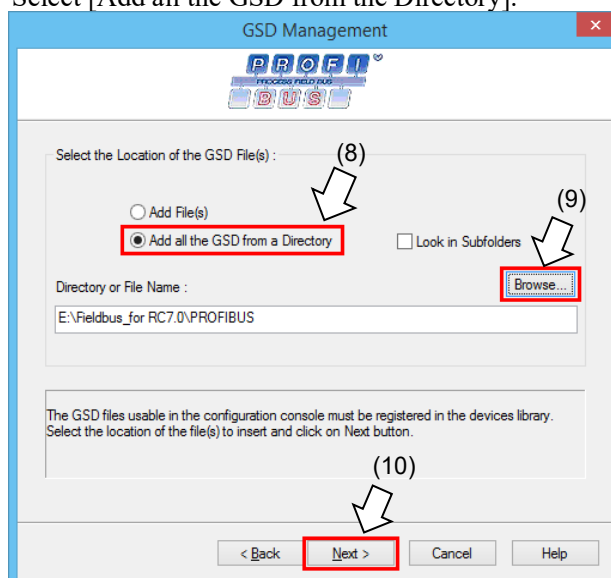

9. Click [Browse].
10. Click [Next].

11. The following dialog box appears. Confirm the retrieved device information.

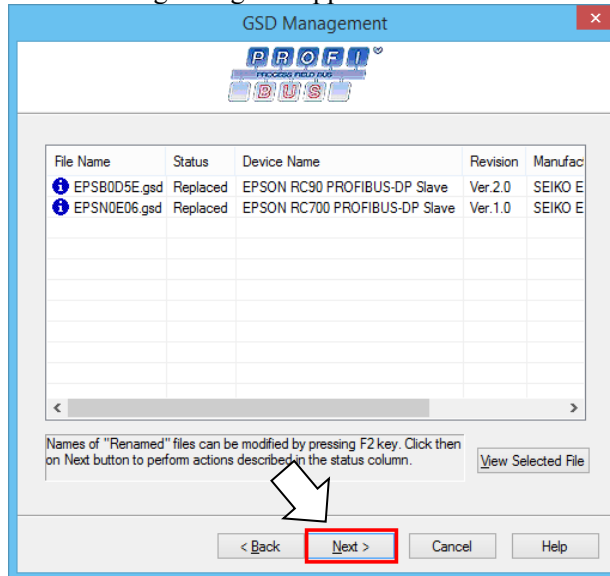

12. Click [Next].
13. The following dialog box appears. Click [Finish] to complete the GSD file registration.



14. Configure the PROFIBUS-DP master.

Select “Protocol” and then select [Description]-[Properties] from the applicomIOR console menu.

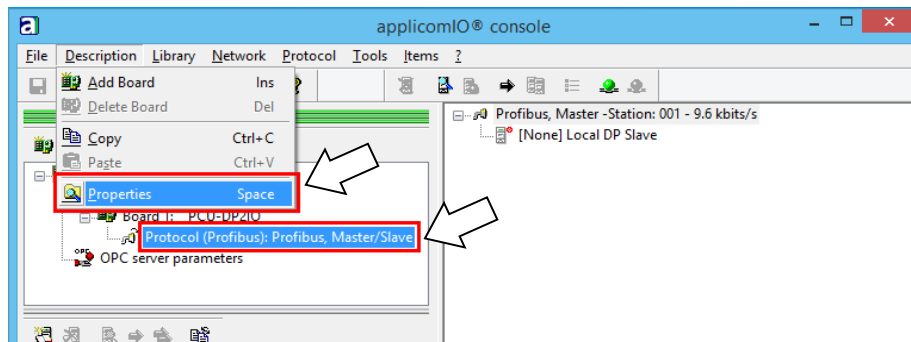

15. The [Channel Properties] dialog box appears.

Select “Profibus, Master/Slave” and click [OK].

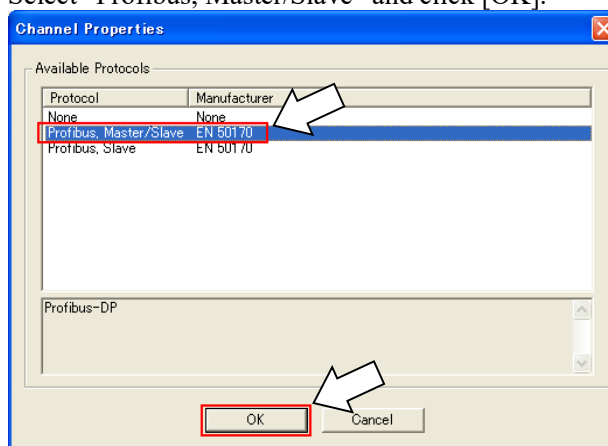

16. Select [Protocol]-[Properties]-[Configuration] from the applicomIOR console menu.

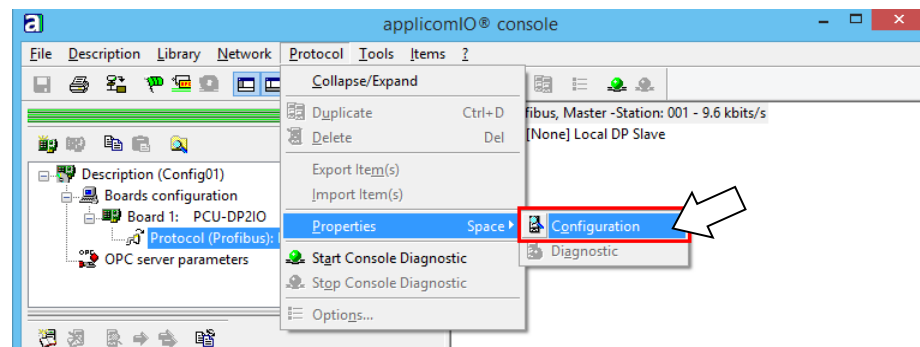

- 17. The [Profibus Master] dialog box appears. Set Baud Rate for the PROFIBUS-DP network, the master address (Profibus Address of this Station), and Highest Station Address in the network.

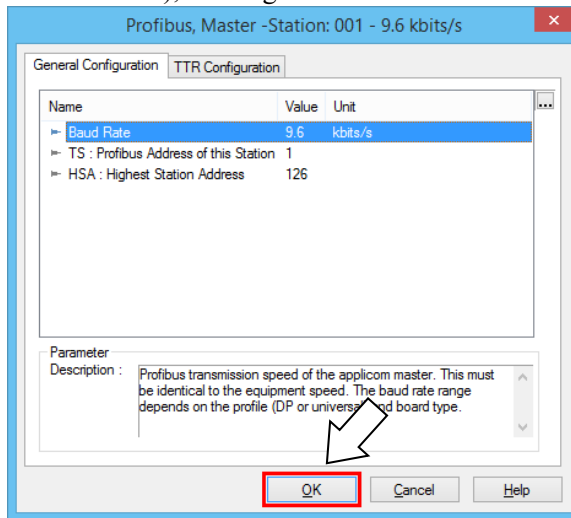

When the PROFIBUS-DP master setting is completed, click [OK].

- 18. Select the [Network Detection] tab.

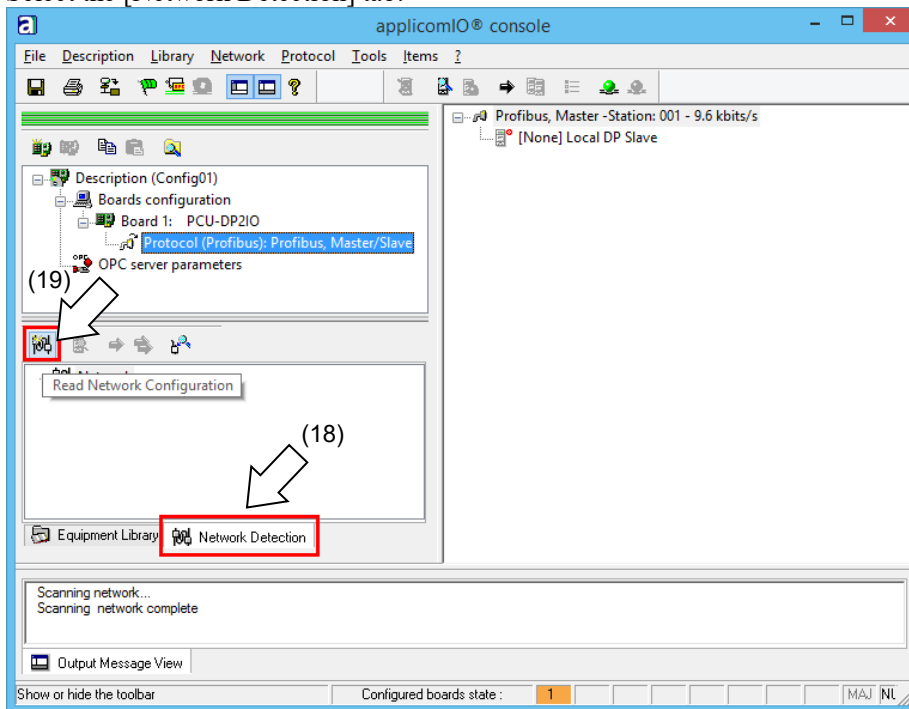

- 19. Click the [Read Network Configuration].
- 20. The following message box appears. Click [Yes].

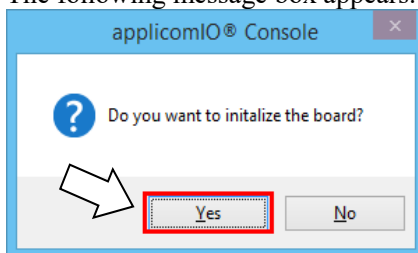

21. The [Profibus Master] dialog box appears.
Set Baud Rate for the PROFIBU-DP network, the master address (Profibus Address of this Station), and Highest Station Address in the network.

Click [OK].

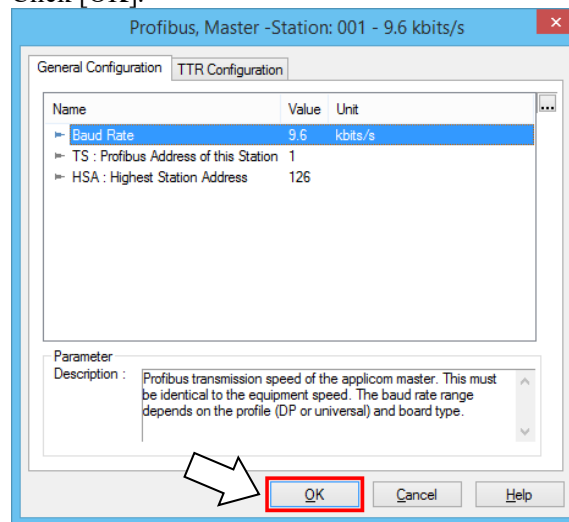

22. The [Network Detection] dialog box appears and starts scanning the device information on the Fieldbus.

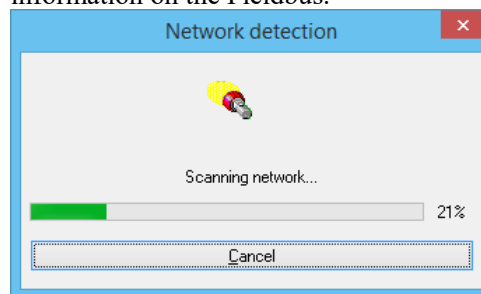

23. The list of detected devices is displayed in the [Network Detection] panel.

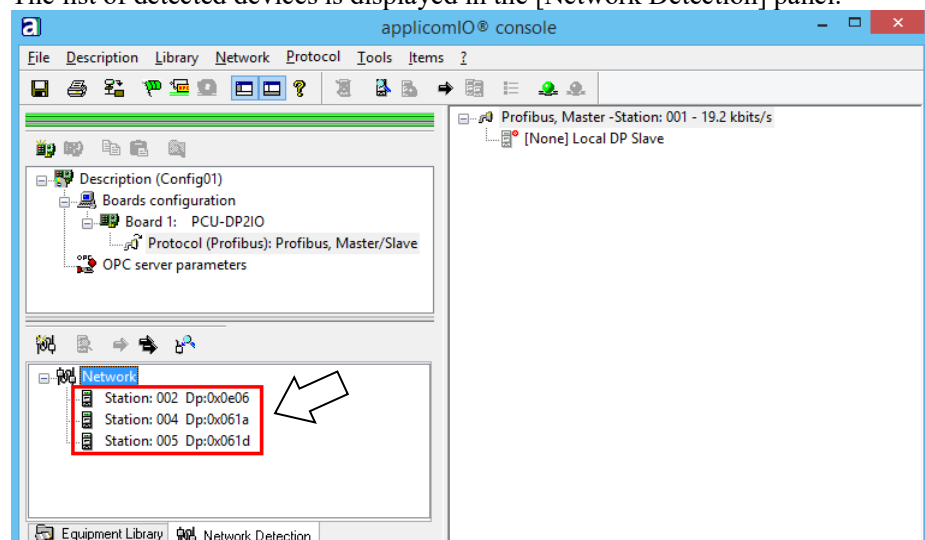

24. Select a device you want to register as slave.

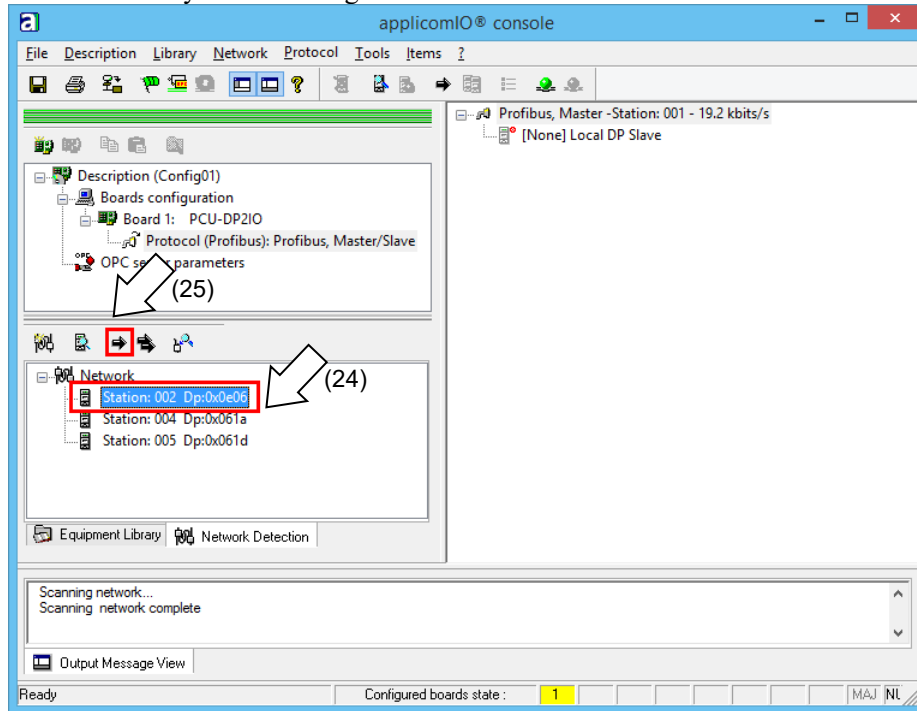

25. Click [Insert in Configuration].

26. The following dialog box appears.
The device name is displayed in the title of the dialog box.

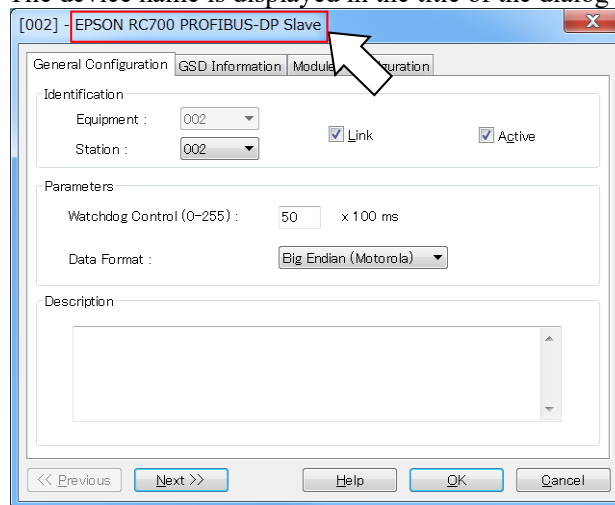

27. Select [Modules Configuration] tab. Connections Parameters appear to communicate with the slave device.

- Displayed items are different depending on the slave device.
- Displayed Connections Parameters are information that is set on the Fieldbus master board.

Make sure that the information matches with that of the slave device.

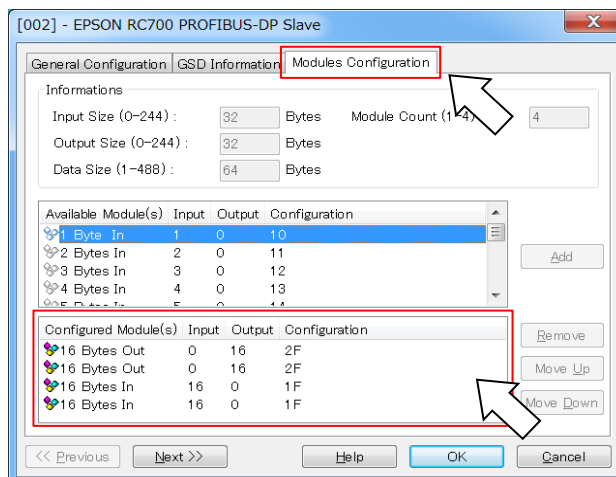

Connections Parameters that are set for the Fieldbus master board and information of the slave device need to be matched.

Communication with the slave device is not performed if they do not match. Change the information of either Connections Parameters or Fieldbus master board.

Please consult with the slave device manufacturer if the information is unclear.

28. Click [OK] to complete the registration.

29. Check the communication status with each slave devices.
Click [Diagnostic].

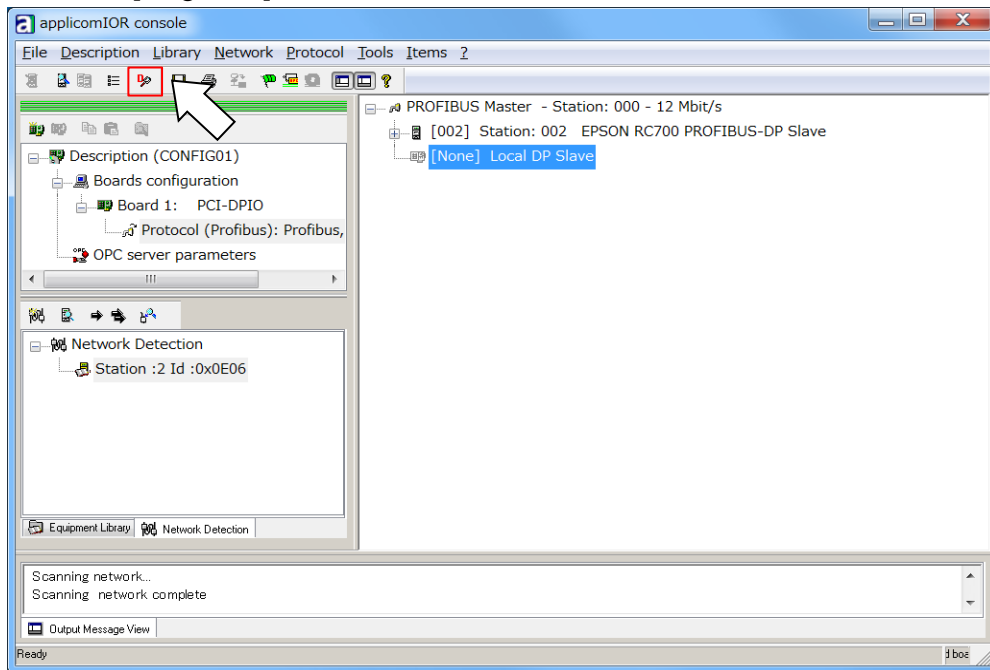

The [Diagnostic Board] dialog box is displayed.

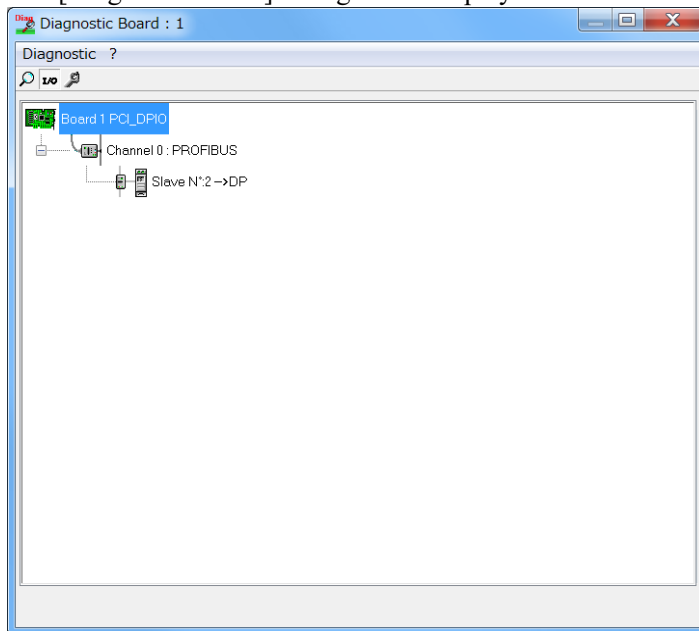

If it cannot communicate with the slave device, the following dialog box appears.

Connections Parameters for the Fieldbus master board and information of the slave device may not be matched.

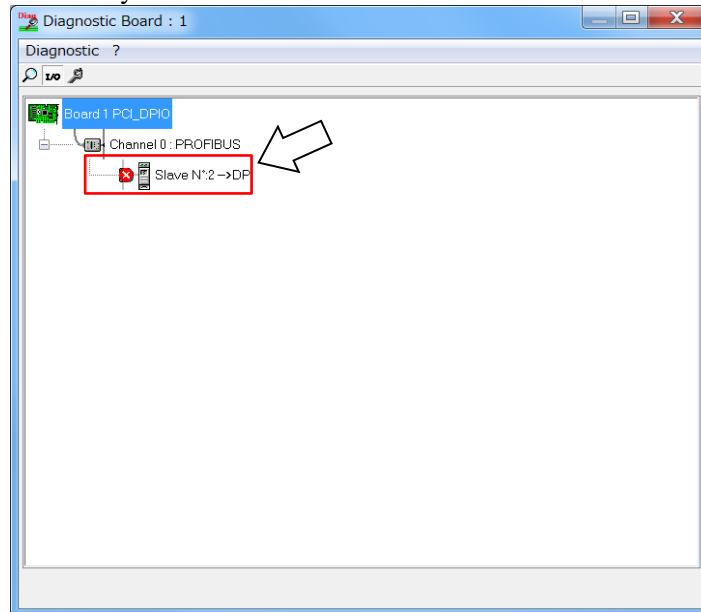

Connections Parameters for the Fieldbus master board can be checked by the following procedure.

First, select the slave device which is registered to the Fieldbus master board.

Then, click the left mouse button and select [Properties].

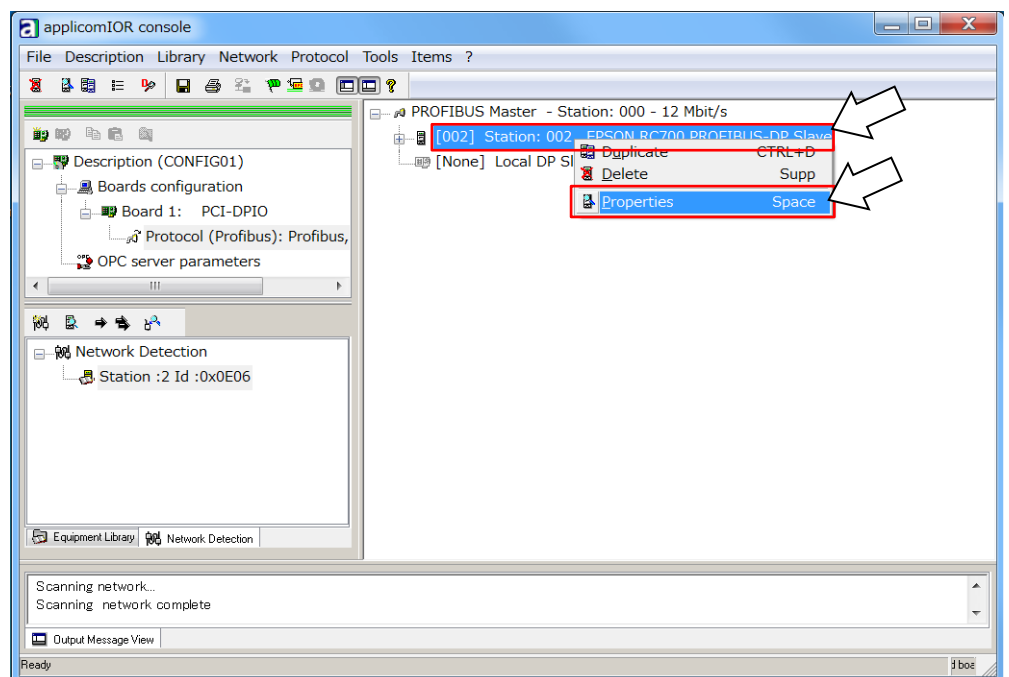

2. Installation

The property information of selected slave device is displayed.

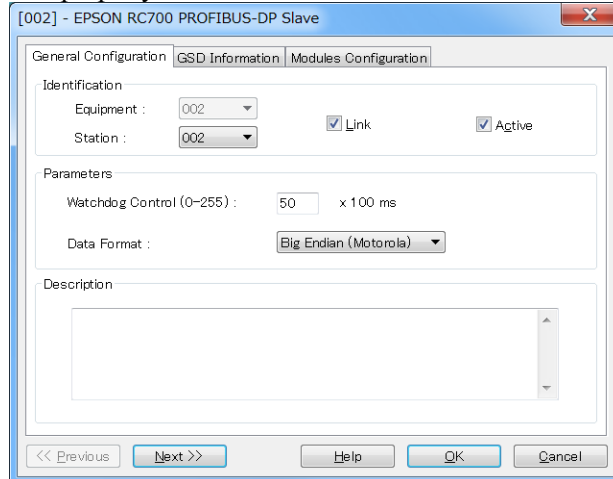

Select the [Connection Configuration] tab.
Connections Parameters appear to communicate with the slave device.

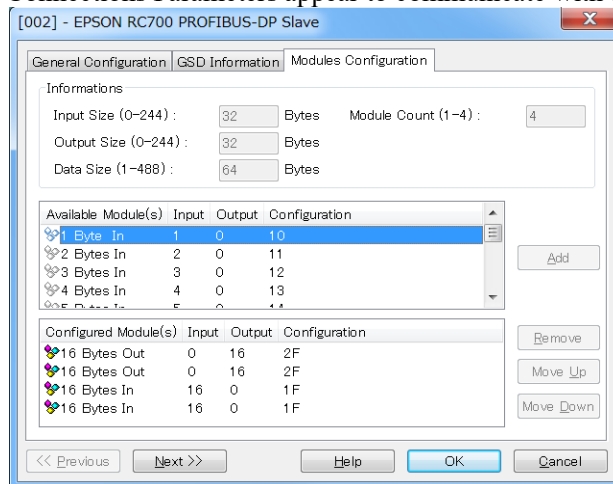

30. Select [File]-[Download in Flash] from the applicomIOR console menu. Register the configuration to the Fieldbus master board.

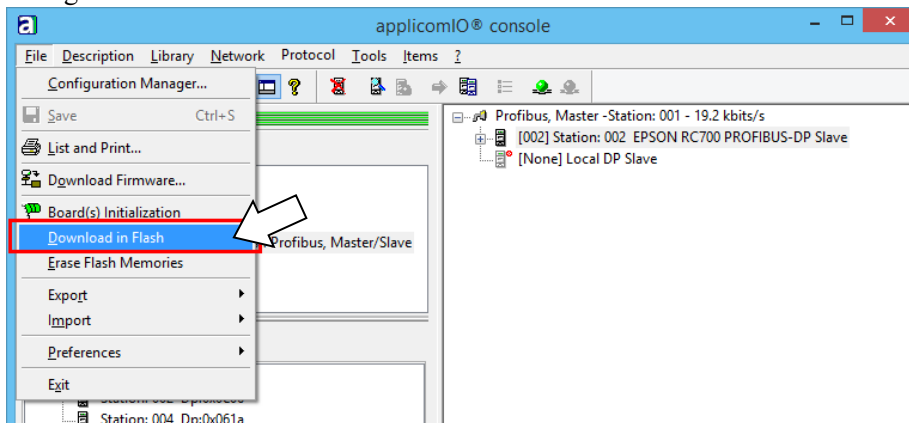

Make sure that the flash memory of the Fieldbus master board stores the configuration; otherwise, the Fieldbus master board cannot correctly function. Also, you cannot control it from Epson RC+ 8.0.

If you changed the configuration, select [File]-[Download in Flash] from the applicomIOR console menu and register the configuration to the Fieldbus master board.

31. After a few seconds, the display of “Configured boards state” on the status bar turns to green.

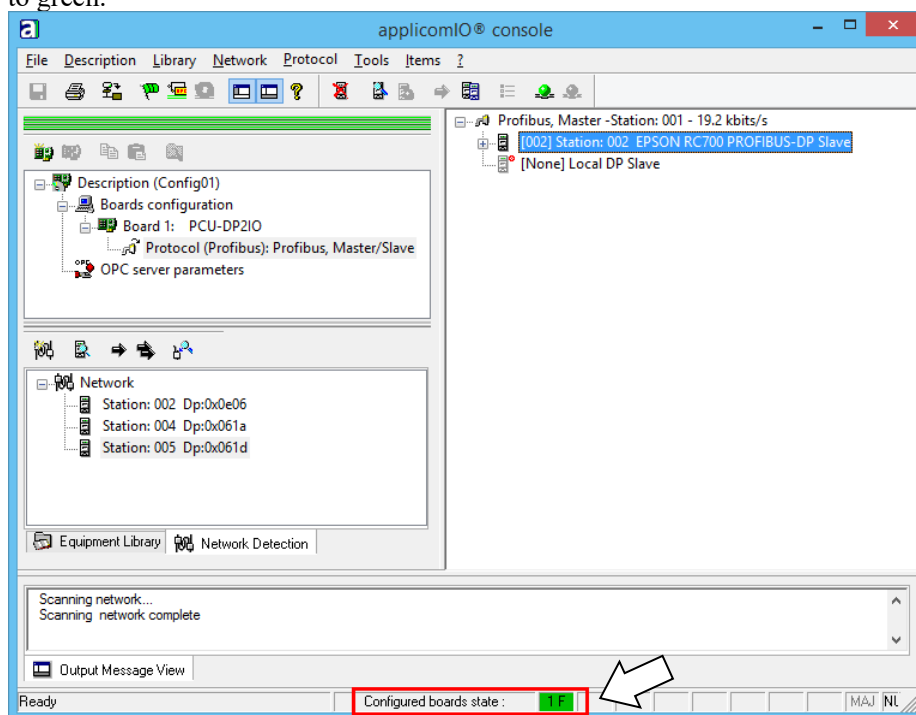

Now, the Fieldbus master board is ready to operate in the master mode.

32. Close the “applicomIO console” application.
33. Refer to the section *Epson RC+ 8.0 Configuration* and continue the step.

NOTE  If there is a problem such as the fieldbus master board is not recognized by Windows, make sure that the combination is described in "Control System Configuration" in the preface of this manual and refer to the following section.

4. Troubleshooting

4.4 How to Disable Fast Startup in Windows

Epson RC+ 8.0 Configuration

To use the Fieldbus master board, the Robot system option setting and Fieldbus master setting should be enabled on Epson RC+ 8.0.

1. Select [Setup]-[License Configuration] and display the [License Configuration] dialog box.
2. Refer to *Epson RC+ User's Guide: Installing Controller Licenses* and enable the Fieldbus Master option.
3. When the following message displays, click the [OK] button.

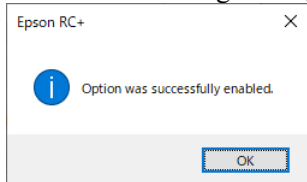

4. Select [Setup]-[System Configuration] and display the [System Configuration] dialog box.
5. Select [Controller]-[Inputs/Outputs]-[Fieldbus Master]-[General].

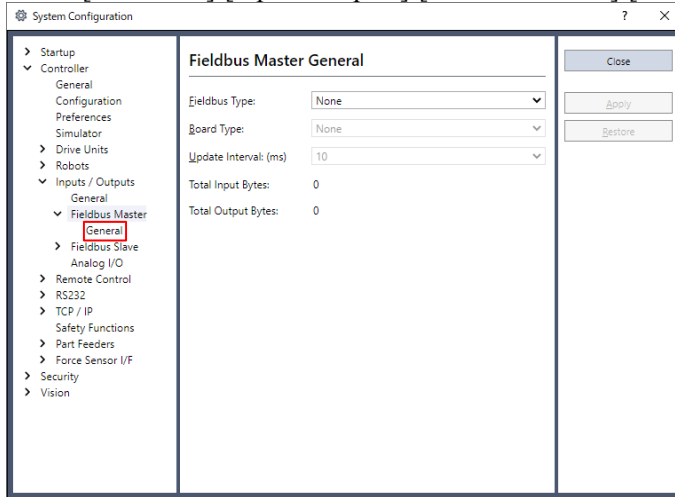

6. Set the following items:
 [Fieldbus Type:] PROFIBUS-DP
 [Board Type:] Molex
 [Update Interval:] Update cycle for the PROFIBUS-DP master I/O

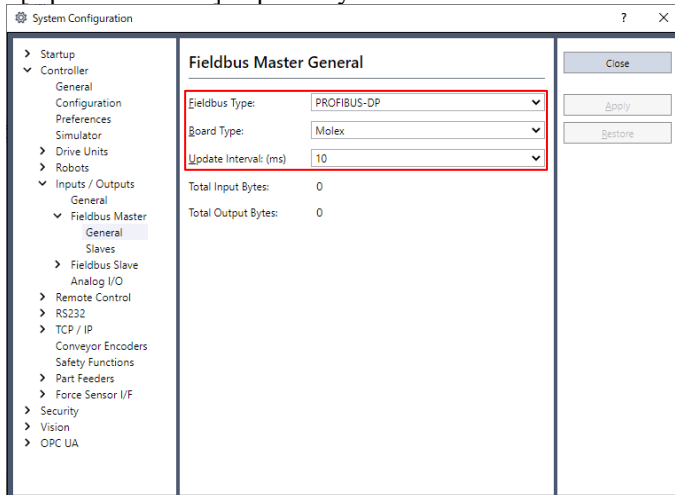

7. Click [Apply].
Confirm that the following is displayed.
 Total Input Bytes : Number of inputs the master controls (Bytes)
 Total Output Bytes : Number of outputs the master controls (Bytes)
8. Click [Close].
The following dialog box appears and the Controller automatically starts rebooting.



9. Select [Setup]-[System Configuration] and display the [System Configuration] dialog box.
10. Select [Controller]-[Inputs / Outputs].

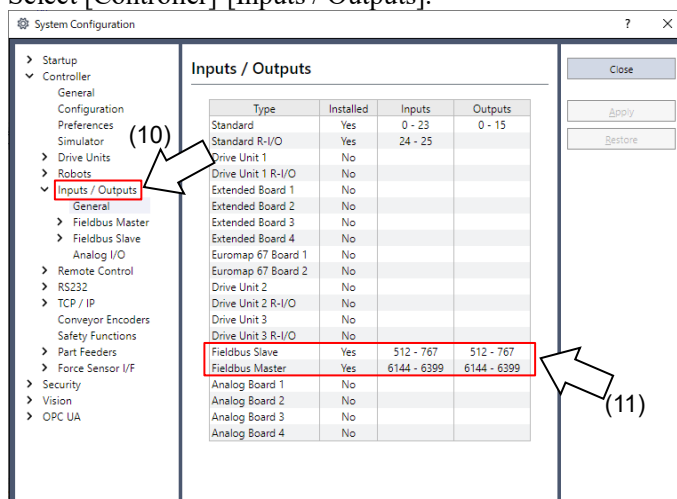

11. Confirm that the following are displayed in "Fieldbus Master".
 Installed : Yes
 Inputs : "6144" – "6144+ Number of inputs the master controls (Bits)"
 Outputs : "6144" – "6144 + Number of outputs the master controls (Bits)"

12. Select [Fieldbus Master]-[General].

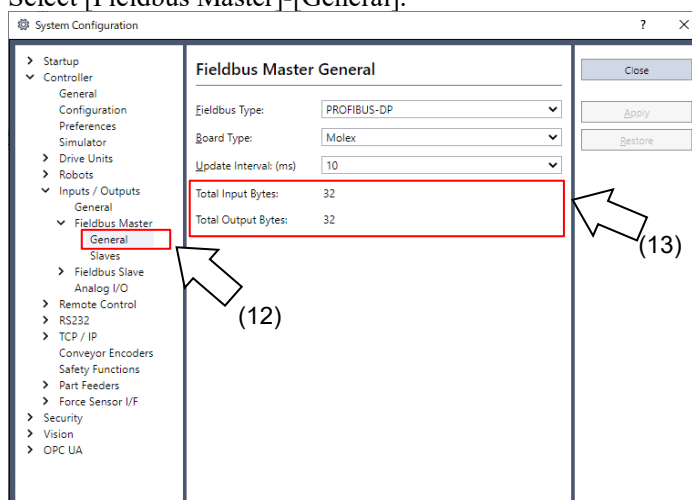

13. Confirm that the following are displayed.
 Total Input Bytes : Number of inputs the master controls (Bytes)
 Total Output Bytes : Number of outputs the master controls (Bytes)

14. Select [Fieldbus Master]-[Slaves].

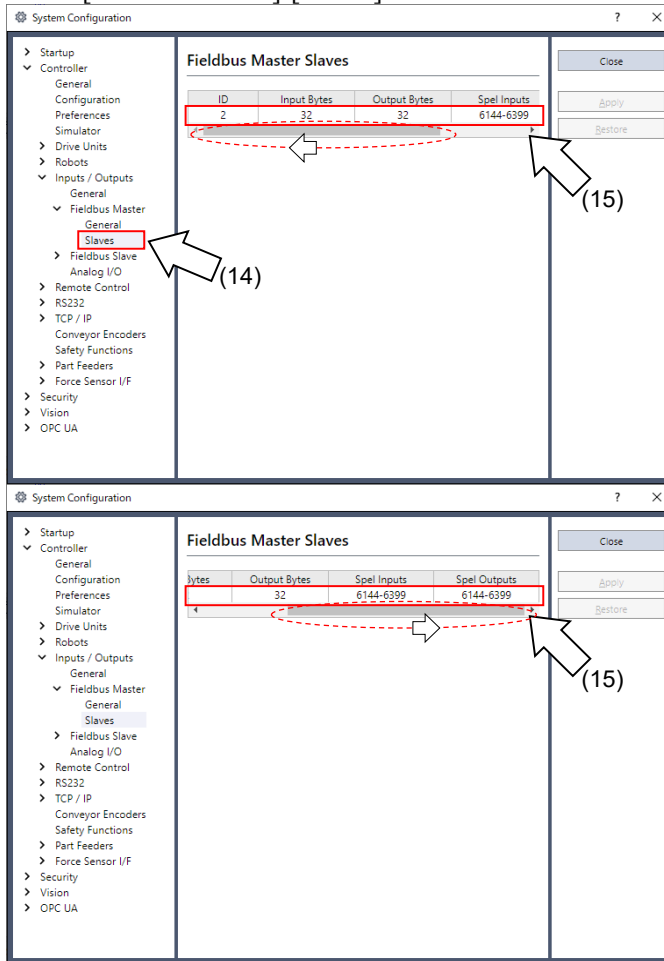

15. Confirm that the following information the master controls is displayed.

- ID : Fieldbus station ID of slave
- Input Bytes : Number of inputs per slave (Bytes)
- Output Bytes : Number of outputs per slave (Bytes)
- Spel Inputs : Number of inputs per slave (Bits)
- Spel Outputs : Number of outputs per slave (Bits)

2.2.4 Installing PROFIBUS-DP Slave Board

Appearance

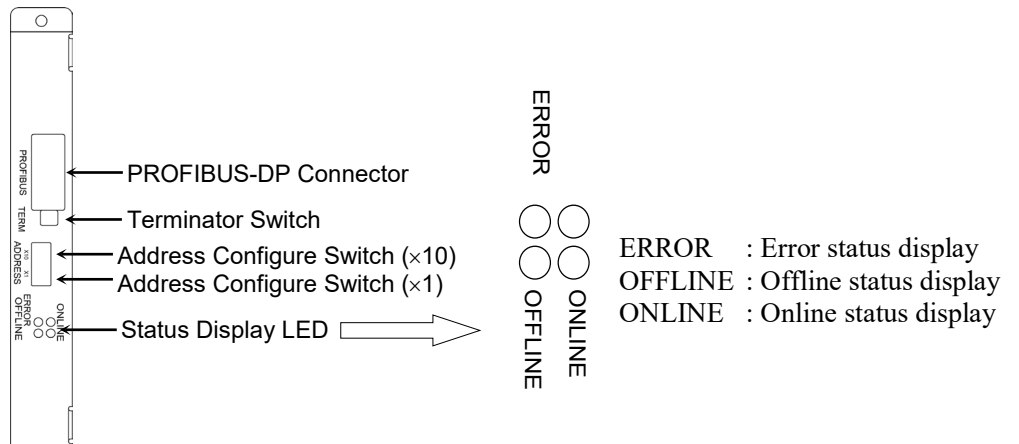

The Fieldbus slave board is configured as follows at shipment.

Board Appearance

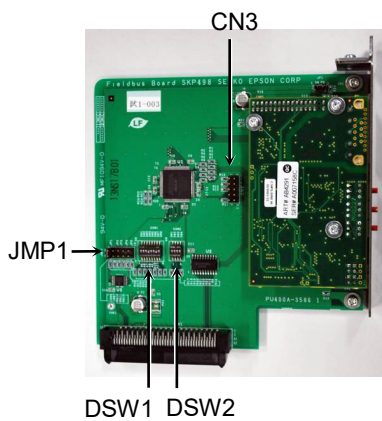

Configuration

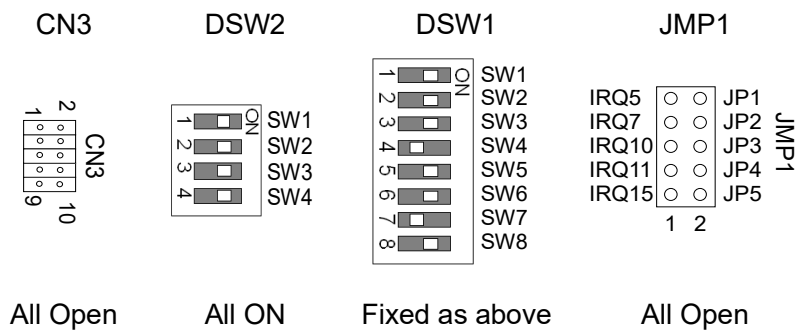

Specifications

Item	Specification	
Name	PROFIBUS-DP slave board	
Connection Method	Hybrid (token passing procedure and master-slave communication)	
Baud Rates (bps)	9.6 k, 19.2 k, 45.45 k, 93.75 k, 187.5 k, 500 k, 1.5 M, 3 M, 6 M, 12 M (bps)	
Transfer Distance	Baud Rates	Cable Length
	12 M (bps)	100 m
	6 M (bps)	100 m
	3 M (bps)	100 m
	1.5 M (bps)	200 m
	500 k (bps)	400 m
	187.5 k (bps)	1000 m
	93.75 k (bps)	1200 m
	45.45 k (bps)	1200 m
19.2 k (bps)	1200 m	
9.6 k (bps)	1200 m	
Maximum Stations	126 (including master unit and repeater)	
Data Length / Frame	244 bytes	
Cable	2-wire cable dedicated to PROFIBUS (2 wires for signal)	
Modes	Slave	
Interface	1 PROFIBUS-DP port (EN 50170)	
Output Current Capacity	Maximum 100 mA	
Max. Input Data Size	1952bits (244bytes) *	
Max. Output Data Size	1952bits (244bytes) *	
DP version	DP-V0	

* The sum of input and output data size is restricted as follows:

For Byte format : 372 bytes

For Word format : 208 words

LED Description

LED state represents the states of the fieldbus board.

LED state	ONLINE GRN	OFFLINE RED	ERROR RED
OFF	Offline	Online	Normal operation
ON	Online Data exchangeable	Offline Data unchangeable	—
1 Hz blinking	—	—	Initialization error (Mismatch with network configuration)
2 Hz blinking	—	—	Initialization error (Mismatch with user parameter)
4 Hz blinking	—	—	Initialization error (Module initialization error)

Setting Configure Switch



- Make sure that the power is turned OFF before installing/removing any boards or connecting/disconnecting any cables. Working with the power ON is extremely hazardous and may result in electrical shock and/or malfunction of equipment.

Set the node address of the device using the address configuration switch of the PROFIBUS-DP slave board. Set network termination ON or OFF with the terminator switch.

1. Set the node address of the PROFIBUS-DP slave board using the address configuration switch. Make sure that the node address is different from the other devices in the network. Switch on the “×10” side is for tenths digit address configuration. Switch on the “×1” side is for units digit address configuration.



NOTE Generally, a node address from 0 to 125 is available for the PROFIBUS-DP device. However, this Robot system supports node addresses from 0 to 99.

Generally, node addresses are recommended to be configured as shown in the table.

Node address	Device Name
0	Service unit such as PG/PC
1	Operation panel such as HMI
2	Master station
3-99 (-125)	DP slave station

2. Turn the network termination ON or OFF using the terminator switch.

Wiring

PROFIBUS-DP connector is standard 9-pins D-sub connector.

Terminal name for each pin

Terminal No	Terminal Name
Case	Shield
1	NC
2	NC
3	B line
4	RTS
5	GND BUS
6	+5V BUS
7	NC
8	A line
9	NC



NOTE Prepare the cable for PROFIBUS-DP sold in the market as a communication cable. Install terminating resistors at both ends of the network. A terminating resistor is installed in the PROFIBUS-DP slave board. Turn the terminating resistor ON or OFF using the terminator switch on the front panel.

Installing a Board



- Make sure that the power is turned OFF before installing/removing any boards or connecting/disconnecting any cables. Working with the power ON is extremely hazardous and may result in electrical shock and/or malfunction of equipment.

Install the board to the dedicated slot on the Robot Controller.

Reference manuals:

RC700 Series Maintenance MANUAL 7.1 Option Board

RC90 Series Maintenance MANUAL 7.1 Option Board

When using RC700-D and RC700-E, please contact the supplier of your region.

Confirmation with Epson RC+ 8.0

When a PROFIBUS-DP slave board is installed to the Controller, it is recognized automatically. Confirm whether Epson RC+ 8.0 has recognized the PROFIBUS-DP board using the following procedure.

1. Select [Setup]-[System Configuration] and display the [System Configuration] dialog box.
2. Select [Controller]-[Inputs / Outputs].

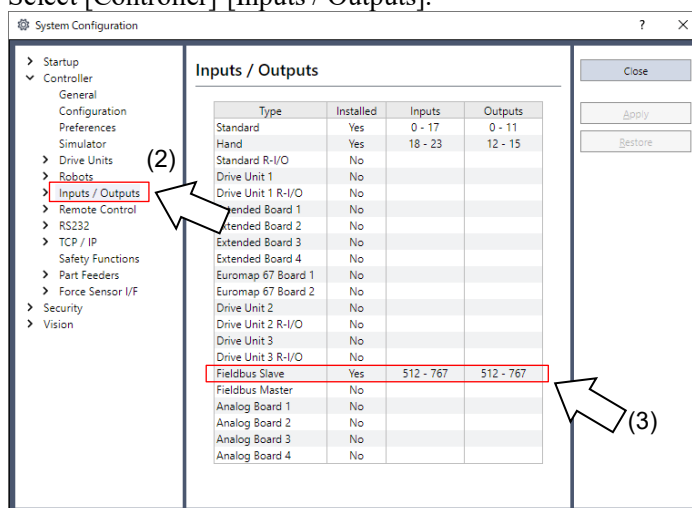

3. Confirm that the following items are displayed in “Fieldbus Slave”.

Installed : Yes
 Inputs : 512-767 (default setting)
 Outputs : 512-767 (default setting)

4. Select [Fieldbus Slave]-[General].

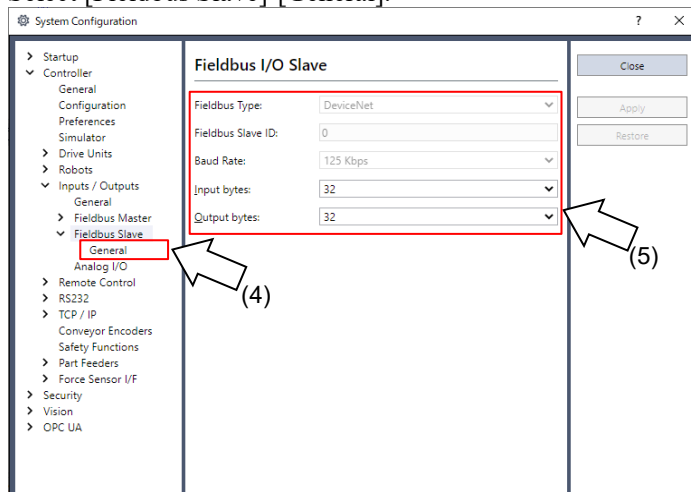

5. Confirm that the following items are displayed.

Fieldbus Type : PROFIBUS-DP
 Fieldbus Slave ID : (Displays the configure switch node address)
 Type : Byte (default setting)
 Input Bytes : 32 (default setting)
 Output Bytes : 32 (default setting)

6. Click [Close].

Editing of Input / Output Size

You can change the input/output size of PROFIBUS-DP slave board if necessary.

1. Select [Setup]-[System Configuration] and display the [System Configuration] dialog box.
2. Select [Controller]-[Inputs / Outputs]-[Fieldbus Slave]-[General].

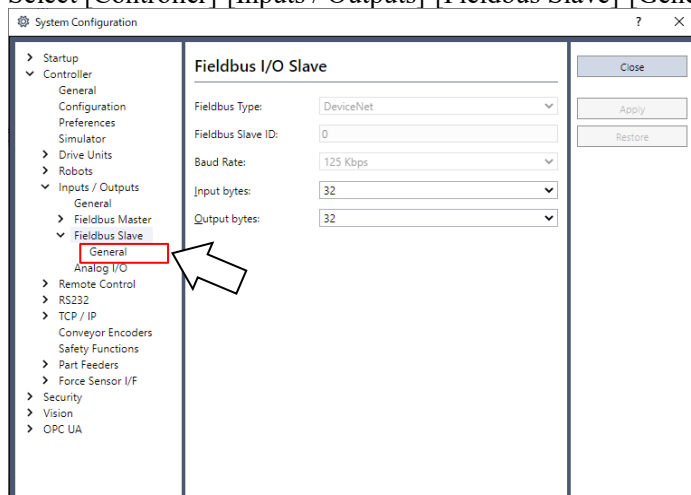

3. Change the settings of [Input Bytes] and [Output Bytes].
In this example, both of them are changed to “20” Bytes.

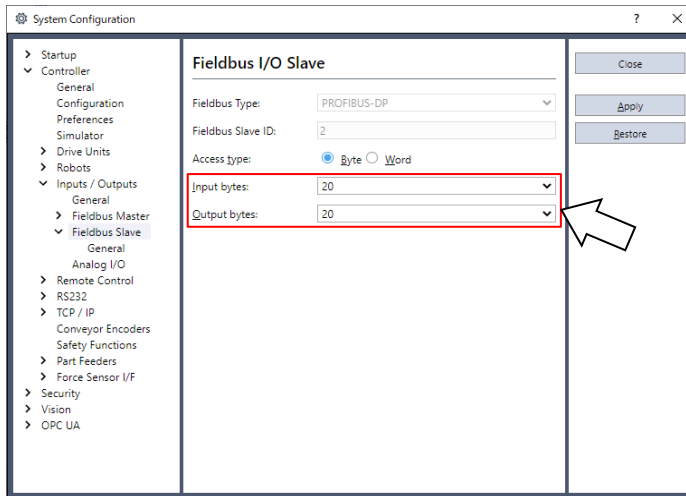

The sum of input and output data sizes is restricted as follows:

- For Byte format : 372 bytes
- For Word format : 208 words

4. Click [Apply].
5. Click [Close].

The following dialog box appears and the Controller automatically starts rebooting.



6. Select [Setup]-[System Configuration] and display the [System Configuration] dialog box.
7. Select [Controller]-[Inputs / Outputs].

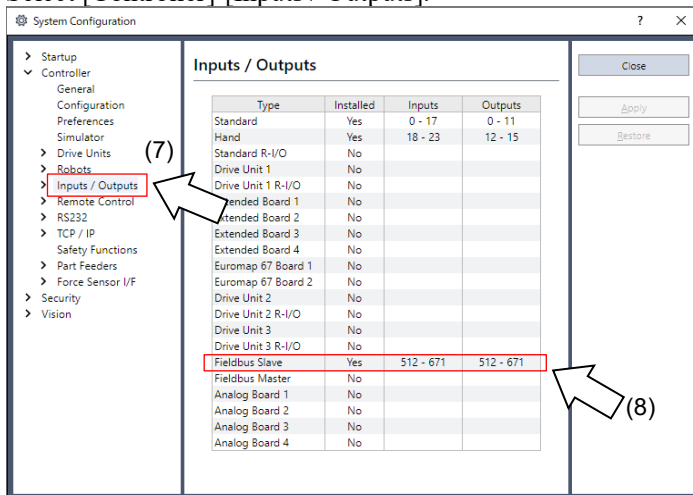

8. Confirm that the following items are displayed in “Fieldbus Slave”.

Inputs : 512 – (512 + Changed number of input (Bits))

Outputs : 512 – (512 + Changed number of output (Bits))

In this example, Input byte is 20 bytes (160 bits) and 512-671 is displayed in Inputs.
Also, Output byte is 20 bytes (160 bits) and 512-671 is displayed in Outputs.

NOTE

When you change the input/output size of PROFIBUS-DP slave board, you need to change the input/output size of the slave information registered in the Fieldbus master device.

Add in order of output module, input module.

Use the window below to change the input/output size of the slave information registered in the Fieldbus master device by the applicomIO console application.

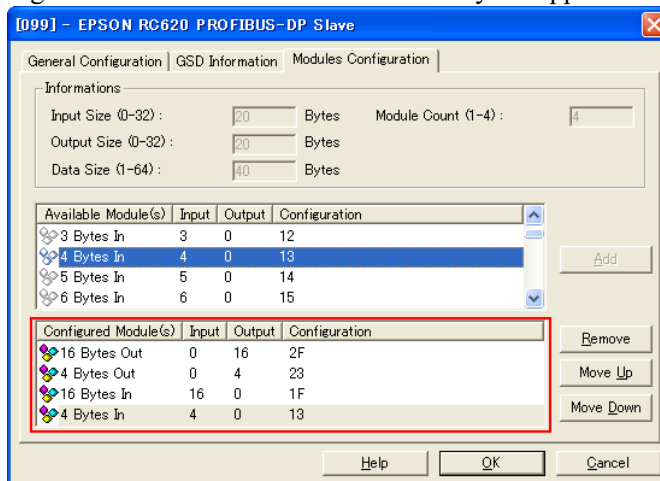

16 Bytes Out	}	Output : 20 Bytes
4 Bytes Out		
16 Bytes In	}	Input : 20 Bytes
4 Bytes In		

Editing of Input / Output Format

You can change the input/output format of PROFIBUS-DP slave board.
Change to the format to “byte” or “word” as necessary.

NOTE

When you change the input/output format of PROFIBUS-DP slave board, you need to change the input/output format of the slave information registered in the Fieldbus master device.

Use the window below to change the input/output format of the slave information registered in the Fieldbus master device by the applicomIO console application.

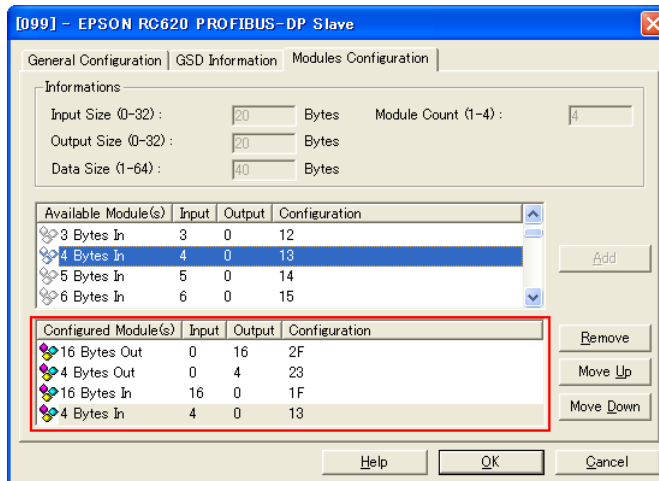

Byte format
 16 Bytes Out } Output: 32Bytes
 16 Bytes Out }
 16 Bytes In } Input: 32Bytes
 16 Bytes In }

Word format
 16 Word Out Output: 32Bytes
 16 Word In Input: 32Bytes

Electronic Information File (GSD file)

A GSD file is supplied for PROFIBUS-DP slave board network configuration. The file is located in the following folder where Epson RC+ 8.0 is installed.

C:\EpsonRC80\Fieldbus\Profibus

Compatible list of GSD file

Controller	File name
RC700 series	EPSN0E06.gsd
RC90 series	EPSB0D5E.gsd

2.2.5 Installing PROFIBUS-DP Slave Module



- Make sure that the power is turned OFF before installing/removing any modules or connecting/disconnecting any cables. Working with the power ON is extremely hazardous and may result in electrical shock and/or malfunction of equipment.



- Pay attention to the followings in order to prevent the the connector from coming off.
 4. Use the connectors attached to the module.
 5. Insert the connectors all the way seated.
 6. Fix the cables at proper positions in order not to put a load on the connectors.

Appearance

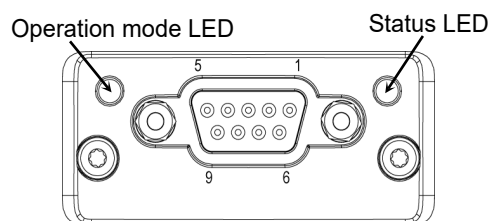

Specifications

Item	Specification	
Name	PROFIBUS-DP slave module	
Connection Method	Hybrid (token passing procedure and master-slave communication)	
Baud Rates (bps)	9.6 k, 19.2 k, 45.45 k, 93.75 k, 187.5 k, 500 k, 1.5 M, 3 M, 6 M, 12 M (bps)	
Transfer Distance	Baud Rates	Cable Length
	12 M (bps)	100 m
	6 M (bps)	100 m
	3 M (bps)	100 m
	1.5 M (bps)	200 m
	500 k (bps)	400 m
	187.5 k (bps)	1000 m
	93.75 k (bps)	1200 m
	45.45 k (bps)	1200 m
	19.2 k (bps)	1200 m
9.6 k (bps)	1200 m	
Maximum Stations	126 (including master unit and repeater)	
Data Length / Frame	244 bytes	
Cable	2-wire cable dedicated to PROFIBUS (2 wires for signal)	
Modes	Slave	
Interface	1 PROFIBUS-DP port (EN 50170)	
Output Current Capacity	Maximum 100 mA	
Max. Input Data Size	1952 bits (244 bytes) *	
Max. Output Data Size	1952 bits (244 bytes) *	

* The sum of input and output data size is restricted as follows:

For Byte format : 372 bytes

For Word format : 208 words

LED Description

LED state represents the states of the fieldbus module.

Operation Mode

LED State	Indication
OFF	Not online / No power
Green	Online, data exchange
Flashing Green	Online, clear
Flashing Red (1 flash)	Parameterization error
Flashing Red (2 flashes)	PROFIBUS Configuration error

Status

LED State	Indication	Comments
OFF	Not initialized	Anybus state = SETUP or NW_INIT
Green	Initialized	Anybus module has left the NW_INIT state
Flashing Green	Initialized, diagnostic event(s) present	Extended diagnostic bit is set
Red	Exception error	Anybus state = EXCEPTION

Setting Configure Switch

The PROFIBUS-DP slave module requires no configurations.

All the PROFIBUS-DP communication configurations are set by the development software (Epson RC+ 8.0).

Wiring

PROFIBUS-DP connector is standard 9-pins D-sub connector.

Terminal name for each pin

Pin	Signal	Description
1	-	-
2	-	-
3	B Line	Positive RxD/TxD, RS485 level
4	RTS	Request to send
5	GND Bus	Ground (isolated)
6	+5 V Bus Output	+5 V termination power (isolated, short-circuit protected)
7	-	-
8	A Line	Negative RxD/TxD, RS485 level
9	-	-
Housing	Cable Shield	Internally connected to the Anybus protective earth via cable shield filters according to the PROFIBUS standard.



Prepare the cable for PROFIBUS-DP sold in the market as a communication cable.

Install terminating resistors at both ends of the network.

A terminating resistor is installed in the PROFIBUS-DP slave module. Turn the terminating resistor ON or OFF using the terminator switch on the front panel.

Installing Module



WARNING

- Make sure that the power is turned OFF before installing/removing any modules or connecting/disconnecting any cables. Working with the power ON is extremely hazardous and may result in electrical shock and/or malfunction of equipment.

Install the module to the dedicated slot on the Controller.

Reference manuals:

T series MAINTENANCE MANUAL 14.6 Fieldbus I/O

T-B series MAINTENANCE MANUAL 14.5 Fieldbus I/O

VT series MAINTENANCE MANUAL 18.7 Fieldbus I/O

RC800 series Service Manual 4.1.3 Fieldbus I/O Module

Confirmation with Epson RC+ 8.0

When a PROFIBUS-DP slave module is installed to the Controller, it is recognized automatically. Confirm whether Epson RC+ 8.0 has recognized the PROFIBUS-DP module using the following procedure.

1. Select [Setup]-[System Configuration] and display the [System Configuration] dialog box.
2. Select [Controller]-[Inputs / Outputs].

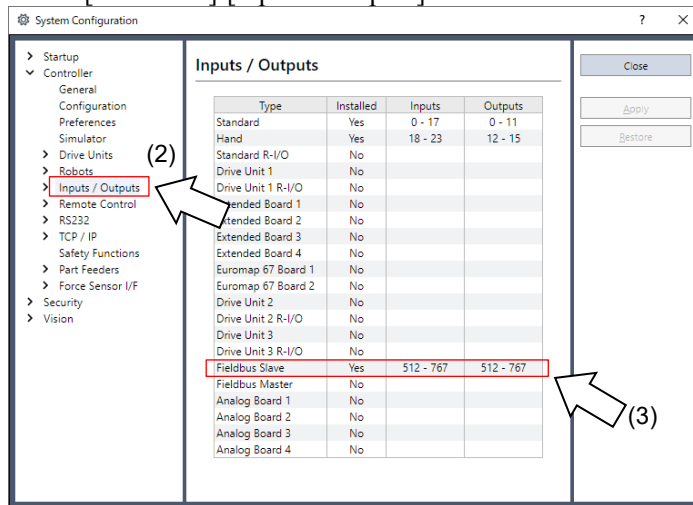

3. Confirm that the following items are displayed in “Fieldbus Slave”.

Installed : Yes
 Inputs : 512-767 (default setting)
 Outputs : 512-767 (default setting)

4. Select [Fieldbus Slave]-[General].

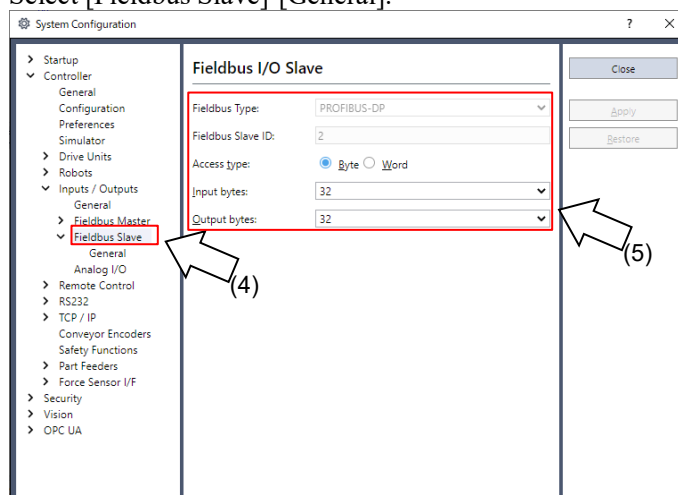

5. Confirm that the following items are displayed.

Fieldbus Type : PROFIBUS-DP
 Node Address : Configure switch node address
 Type : Byte (default setting)
 Input Bytes : 32 (default setting)
 Output Bytes : 32 (default setting)

6. Click [Close].

Editing of Configuration

You can change the configuration of PROFIBUS-DP slave module if necessary.

1. Select [Setup]-[System Configuration] and display the [System Configuration] dialog box.
2. Select [Controller]-[Inputs / Outputs]-[Fieldbus Slave]-[General].

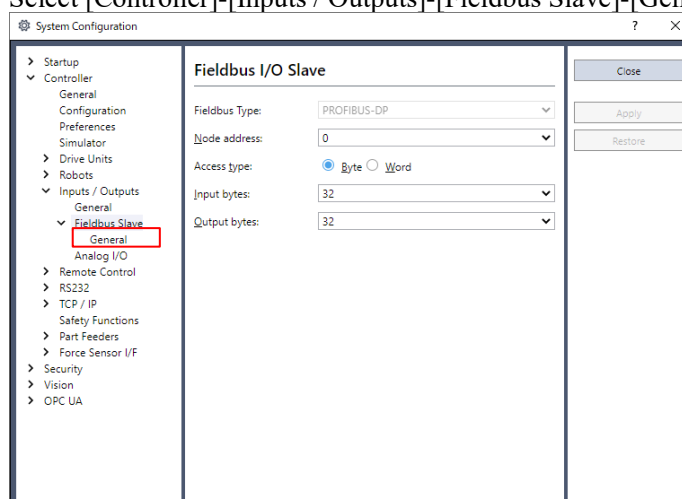

2. Installation

3. Configure a node address.

A node address from 0 to 125 is available for the PROFIBUS-DP device.

Generally, node addresses are recommended to be configured as shown in the table.

Node address	Device Name
0	Service unit such as PG/PC
1	Operation panel such as HMI
2	Master station
3-125	DP slave station

4. Change the settings of [Input Bytes] and [Output Bytes].

The sum of input and output data sizes is restricted as follows:

For Byte format : 372 bytes

For Word format : 208 words

5. Click [Apply].

6. Click [Close].

The following dialog box appears and the Controller automatically starts rebooting.



7. Select [Setup]-[System Configuration] and display the [System Configuration] dialog box.

8. Select [Controller]-[Inputs / Outputs].

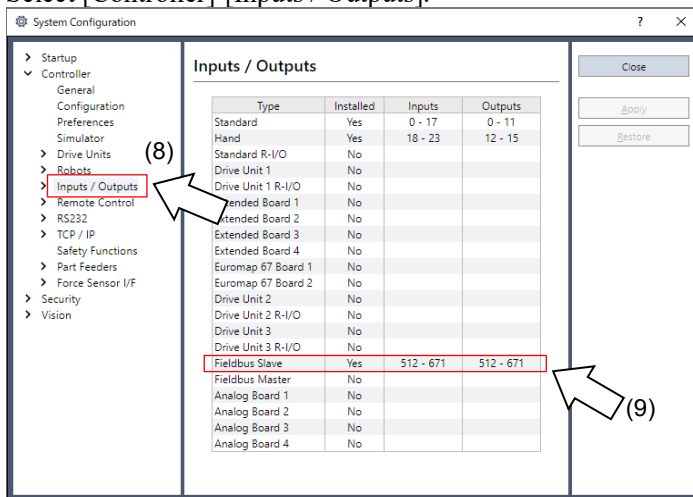

9. Confirm that the following items are displayed in “Fieldbus Slave”.

Inputs : 512 – (512 + Changed number of input (Bits))
 Outputs : 512 – (512 + Changed number of output (Bits))

In this example, Input byte is 20 bytes (160 bits) and 512-671 is displayed in Inputs.

Also, Output byte is 20 bytes (160 bits) and 512-671 is displayed in Outputs.

NOTE

When you change the input/output size of PROFIBUS-DP slave module, you need to change the input/output size of the slave information registered in the Fieldbus master device.

Add in order of output module, input module.

Use the window below to change the input/output size of the slave information registered in the Fieldbus master device by the applicomIO console application.

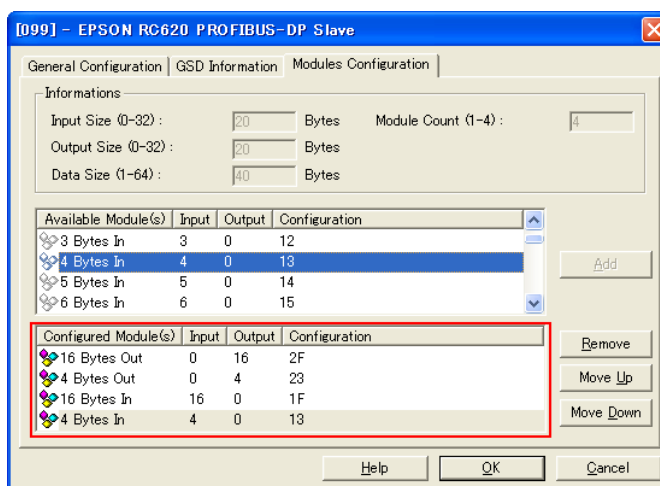

16 Bytes Out } Output : 20 Bytes
 4 Bytes Out }
 16 Bytes In } Input : 20 Bytes
 4 Bytes In }

Editing of Input / Output Format

You can change the input/output format of PROFIBUS-DP slave module.
Change to the format to “byte” or “word” as necessary.

NOTE

When you change the input/output format of PROFIBUS-DP slave module, you need to change the input/output format of the slave information registered in the Fieldbus master device.

Use the window below to change the input/output format of the slave information registered in the Fieldbus master device by the applicomIO console application.

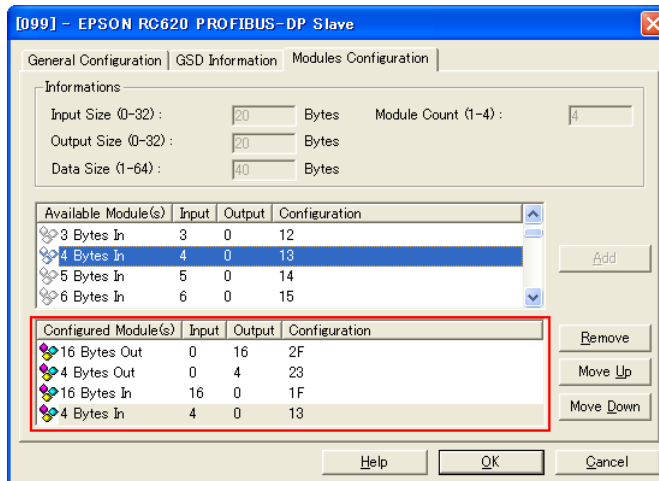

Byte format
 16 Bytes Out } Output: 32Bytes
 16 Bytes Out }
 16 Bytes In } Input: 32Bytes
 16 Bytes In }

Word format
 16 Word Out Output: 32Byte
 16 Word In Input: 32Byte

Electronic Information File (GSD file)

A GSD file is supplied for PROFIBUS-DP slave module network configuration. The file is located in the following folder where Epson RC+ 8.0 is installed.

C:\EpsonRC80\Fieldbus\Profibus

Compatible list of GSD file

Controller	File name
RC800 series	EPSN11E7.gsd
T/VT series	EPSN0FED.gsd

2.3 EtherNet/IP



- Make sure that the power is turned OFF before installing/removing any boards or connecting/disconnecting any cables. Installing/removing any boards or connecting/disconnecting any cables with the power ON is extremely hazardous and may result in electric shock and/or malfunction of equipment.

2.3.1 How to Setup a EtherNet/IP Network

The following is a basic procedure for setting up an EtherNet/IP network:

1. Choose node layout and pathway in your network.
For details, refer to the following section *2.3.2 EtherNet/IP Network Construction*.
2. Lay cables.
For details, refer to the following section *2.3.2 EtherNet/IP Network Construction*.
3. Configure nodes.
For details, refer to respective manuals of your desired nodes.
4. Turn ON the nodes.
5. Install the EtherNet/IP board in your Controller.
Refer to the following for the fieldbus type you have.
 - When installing an EtherNet/IP master board manufactured by molex:
Refer to *2.3.3 Installing an EtherNet/IP Master Board Manufactured by molex*
 - When installing an EtherNet/IP master board manufactured by Hilscher:
Refer to *2.3.4 Installing an EtherNet/IP Board Manufactured by Hilscher*
 - When installing an EtherNet/IP slave board:
Refer to *2.3.5 Installing an EtherNet/IP Slave Board*.
 - When installing an EtherNet/IP slave module:
Refer to *2.3.6 Installing an EtherNet/IP Slave Module*.

When using AOI (Add-On-Instructions) functions by PLC of Rockwell (Allen-Bradley), refer to the following manual.

Epson RC+ 8.0 Option PLC Function Block

Also, when using PLC of Rockwell (Allen-Bradley), please use EPSN0601
EPSNxxxx_Rockwell.eds.

6. Operate the EtherNet/IP network.

2.3.2 EtherNet/IP Network Construction

Network Configuration

EtherNet/IP network is configured as shown in the following figure.

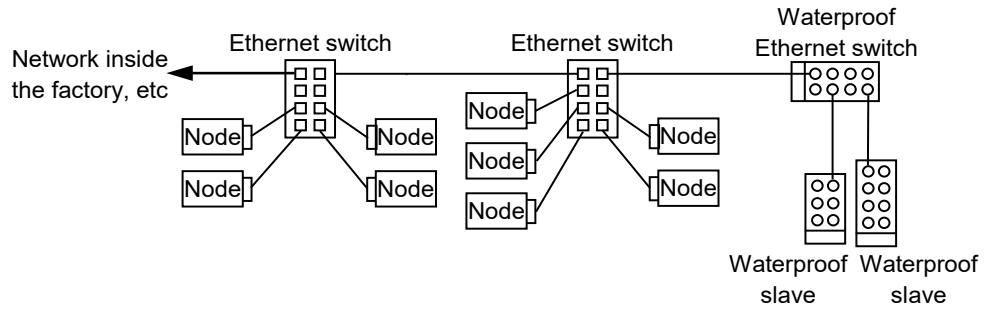

Node

There are two types of node: master and slave. The master controls a network and gathers data from its slaves. The slaves, including external I/O and other devices, output data in response to the master's output order and informs the master of its input status.

You can install the master anywhere in the network. One master node can control up to 127 nodes.

Universal Ethernet cable is used for EtherNet/IP. Use a proper cable such as environmental resistance and refraction resistance that fulfills the environment.

For details, see the website of ODVA. (<https://www.odva.org/>)

Wiring

Wirings should be conformed to EtherNet/IP connection protocol.



You can use the general Ethernet hub or Ethernet switch for the EtherNet/IP. However, be sure to use a product complying with the industrial standards or noise resistant Ethernet cable (STP cable). If you use an office use product or UTP cable, it may cause communication errors and may not offer the proper performance.

2.3.3 Installing EtherNet/IP Master Board Manufactured by molex

Appearance

Part names and functions of the EtherNet/IP Master Board manufactured by molex are shown in the following figure. For details on the status display LEDs, refer to 4.

Troubleshooting in this manual.

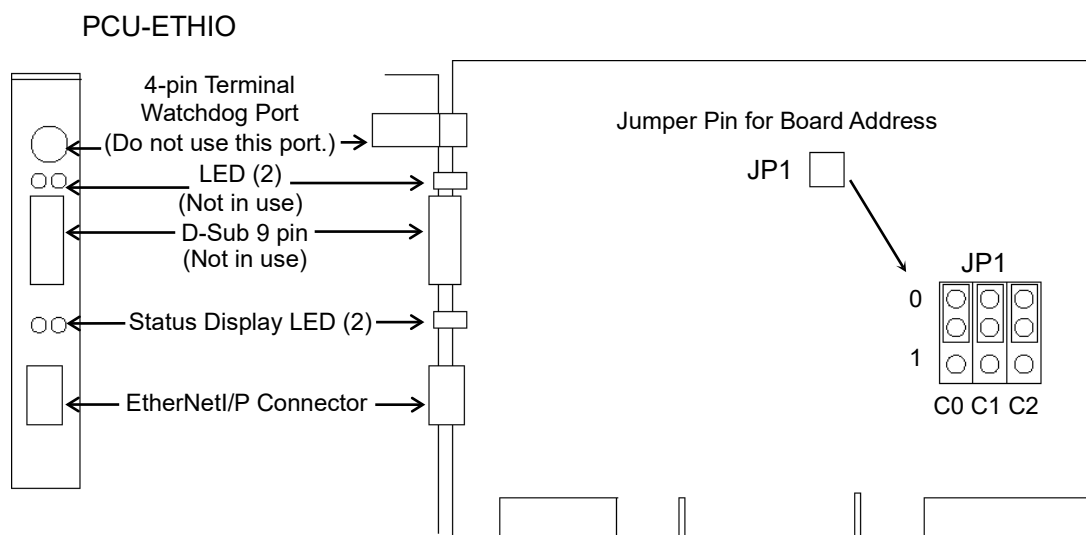

Specifications

Item	Specification
Part Number	EtherNet/IPMaster Board manufactured by molex
Mode	Master
Baud Rates	10, 100 (Mbps)
Interface	EtherNet/IP 1 port
Maximum Node	127
Connection Type	Cyclic, Change of State
Explicit message connection	Yes
EDS support	Yes
Max. Input Data Size	1024 bit (128 bytes)
Max. Output Data Size	1024 bit (128 bytes)
Automatic Detection	Yes. Devices can be detected automatically.

Modes

EtherNet/IP master board manufactured by molex has the Master mode and Slave mode as the motion mode. However, do not select the Slave mode.

Master mode

The Master device gathers and controls all nodes in one network.

EtherNet/IP master can control up to 127 nodes (max. 128 bytes) on one network.

PLC is typically configured as a master and controls all nodes in factory automation system, but Epson RC+ is also capable of being a master.

EtherNet/IP network configuration is specified by configuration management software. This software is normally provided by a master device manufacturer. The configuration management software determines parameters for each slave device via an Electronic Data Sheet (EDS).

Available connection types are Cyclic, Change Of State, and Explicit messaging.

Available baud rates are 100 Mbps and 10 Mbps. (auto-detect)

For the instruction of configuration, refer to the section *Master Mode* later in this chapter.

Installing Software

Before installing the EtherNet/IP master board manufactured by molex to the PC with Epson RC+ 8.0 installed, you must install the applicomIO Console application and drivers according to the type of board you are using.

1. Insert the applicomIO Console CD-ROM to the PC with Epson RC+ 8.0 installed.
2. The dialog box shown below appears. Select “Run setup.exe”.

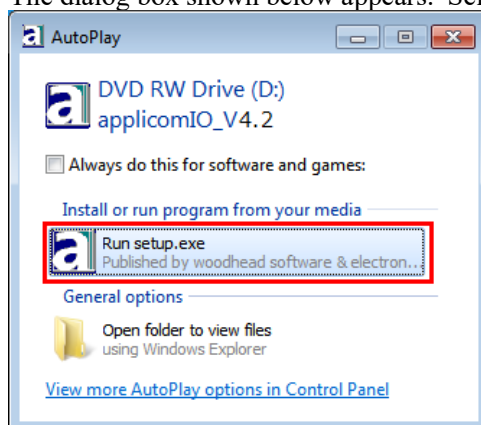

3. The [Summary] dialog box appears. Select “Product Installation”.



4. The [Installation] dialog box appears. Select “applicomIO”.

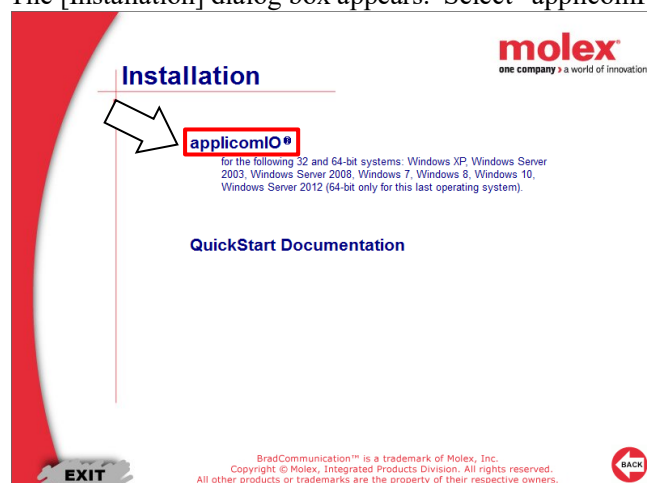

5. If the Microsoft.NET Framework 4.0 is not installed, following dialog box appears. Click [Install].

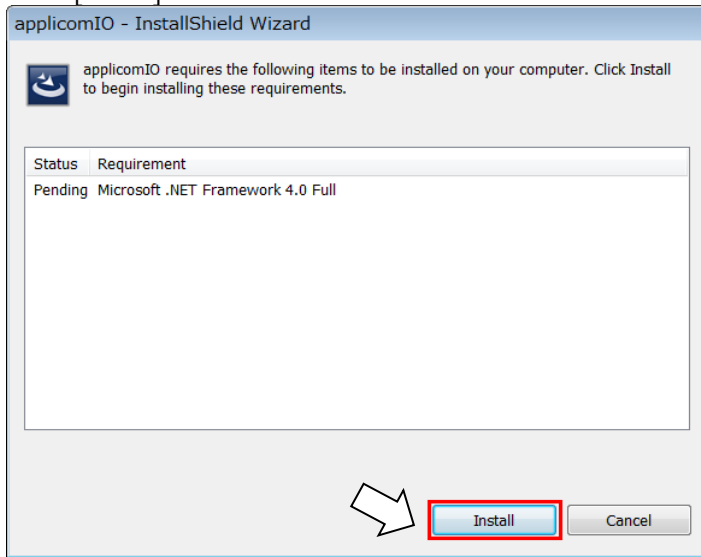

6. The applicomIO Console application installer runs and the [Welcome to the InstallShield Wizard for applicomIO] dialog box appears. Click [Next].

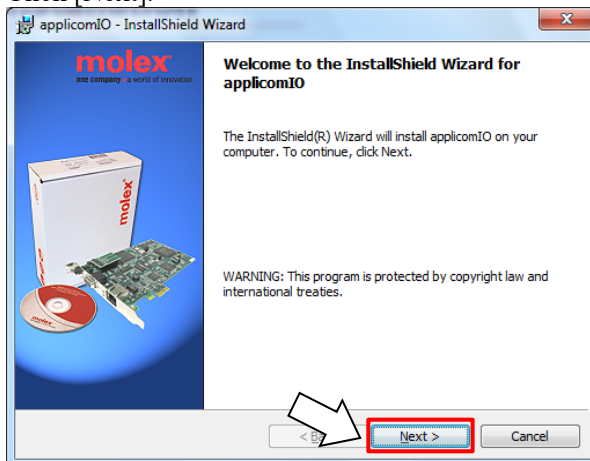

7. The [License Agreement] dialog box appears. Read the software license agreement and click [Next].

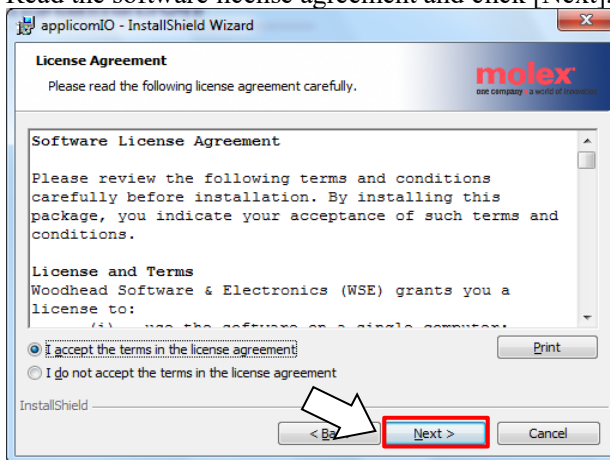

8. The [Customer Information] dialog box appears. Now register the user information. Enter the User Name and Organization.

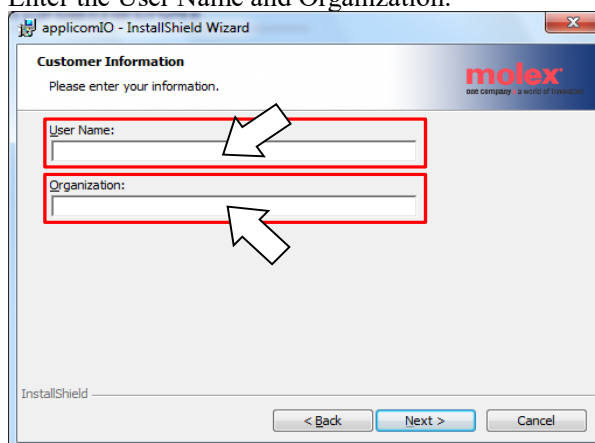

9. The [Destination Folder] dialog box appears. Specify the installation folder for the applicomIO Console application. The default specifies here:
C:\Program Files(x86)\BradCommunications\applicomIOV4.2
If you agree to the default installation folder, click [Next].

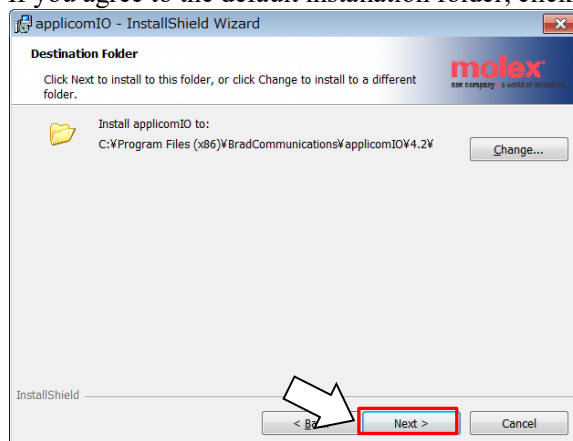

10. The [Ready to Install the Program] dialog box appears. Click [Install].

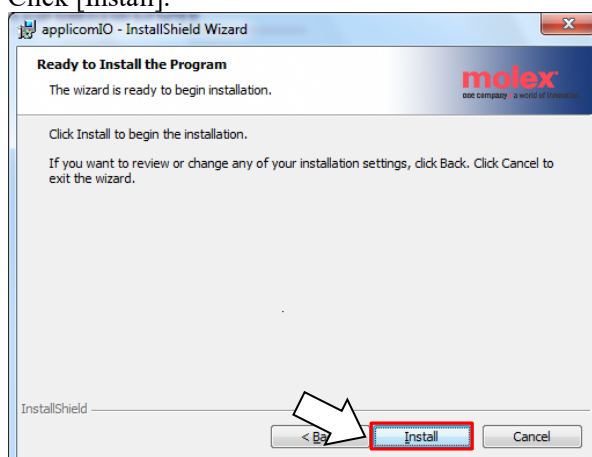

11. Installation of applicomIO Console application starts.
After the installation completes, the [InstallShield Wizard Completed] dialog box appears.
Click [Finish].

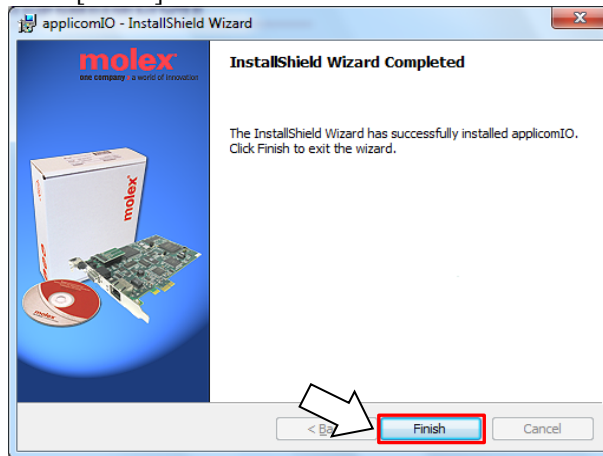

12. The message prompting you to reboot your PC appears.
Select [Yes] and reboot the PC.

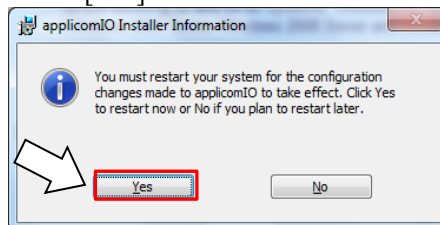

13. Refer to the next section *Installing a Board* to install the EtherNet/IP master board manufactured by molex.

Installing a Board



- Make sure that the power is turned OFF before installing/removing any boards or connecting/disconnecting any cables. Working with the power ON is extremely hazardous and may result in electric shock and/or malfunction of equipment.

1. Configure the board address jumper (JP1) on EtherNet/IP master board manufactured by molex.

You can install one Fieldbus master board to the PC with Epson RC+ 8.0 installed.

The board number should be “1”.

Refer to the following table for JP1 configuration.

Short Socket Board No.	C0	C1	C2
1	0: Short	0: Short	0: Short

2. Install the EtherNet/IP master board manufactured by molex to the PCI bus of the PC with Epson RC+ 8.0 installed. Installation methods of the EtherNet/IP master board manufactured by molex to the PCI bus and how to open the cover differ depending on the type of PC. Refer to the manuals of each PC on how to install the board to the PCI bus.
3. Connect the EtherNet/IP master board manufactured by molex with the EtherNet/IP network.
4. Start up the PC.
5. Open the [applicomIO Console] installation folder and start the “applicomIO Console” application.

Following is specified for [applicomIO Console] installation folder as default.

C:\Program Files(x86)\BradCommunications\applicomIO\4.2



consoleio.exe

6. The [applicomIOR console] dialog box appears. Add the EtherNet/IP master board manufactured by molex. Click [Add Board].

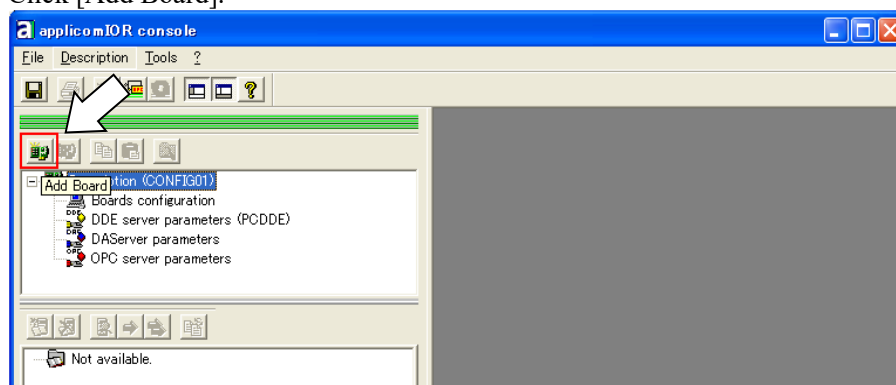

- 7. The [Add New Board] dialog box appears. Confirm that “PCI/PCU-ETHIO” is displayed in [Board to Add]-[Board Type] and click [OK].

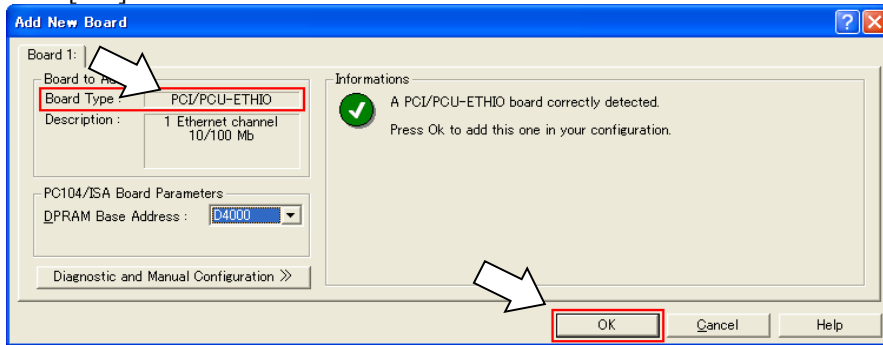

If the board cannot be detected, the following dialog box appears. Make sure that the board is correctly inserted.

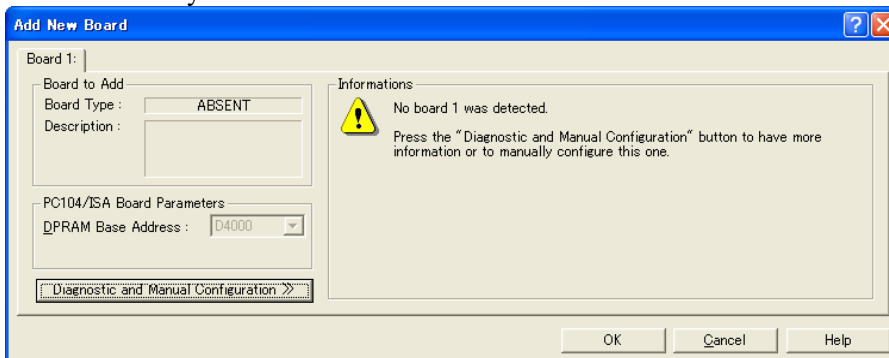

- 8. The [Channel Properties] dialog box appears. Select [Protocol]-[EtherNet/IP] and click [OK].

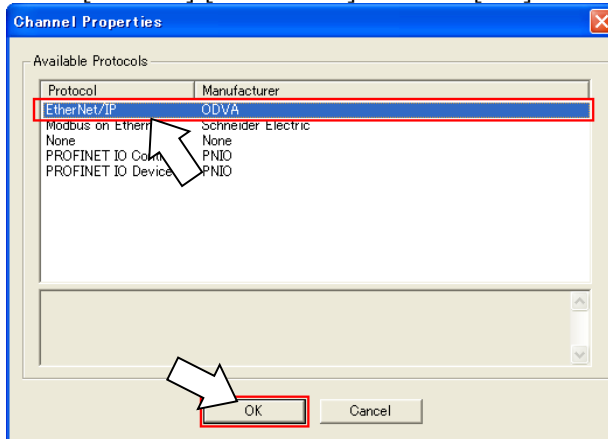

9. The following dialog box appears. Set the IP address for the EtherNet/IP master board manufactured by mollex.

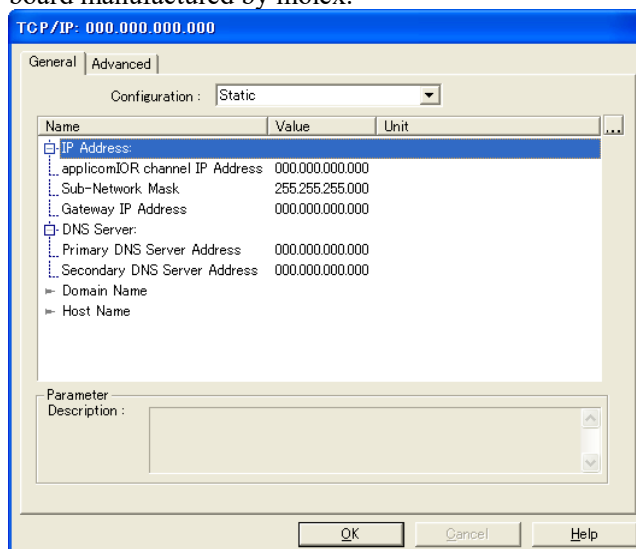

Select the IP address from [Configuration]. There are following three types.
(Do not select “Flash Memory”)

- “Static (assign as fixed IP address)”
- “DHCP (obtain from the DHCP server)”
- “BOOTP (obtain from the BOOTP server)”

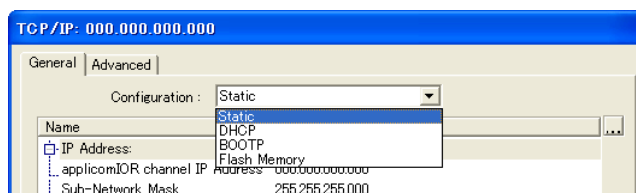

If you select “Static (Fixed IP address)”, enter the values in each item.

10. When you complete adding the EtherNet/IP master board manufactured by mollex to the applicomIO Console application, reboot the PC.

- 10-1 Shutdown the applicomIO Console application.

When the applicomIO Console application shuts down, the following dialog box appears. Click [Yes].

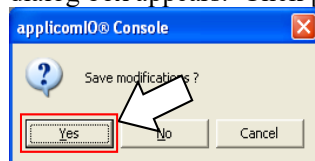

- 10-2 Then, the following dialog box appears. Click [OK].

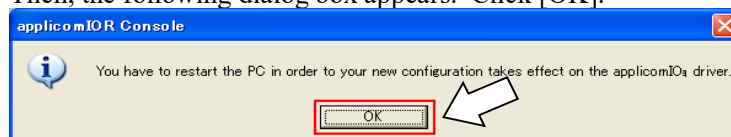

- 10-3 Reboot the Windows.

11. After the PC is rebooted, refer to the next section *Master Mode* and continue the step.

Master Mode

1. Check that the EtherNet/IP master board manufactured by molex is connected to the EtherNet/IP network.
2. Start “applicomIO Console” application.

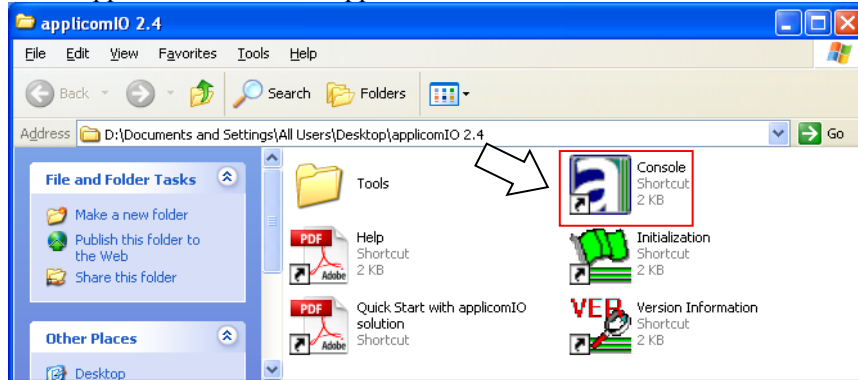

3. The [applicomIOR console] dialog box appears. Register the device information (EDS file) that is necessary for the network setup.

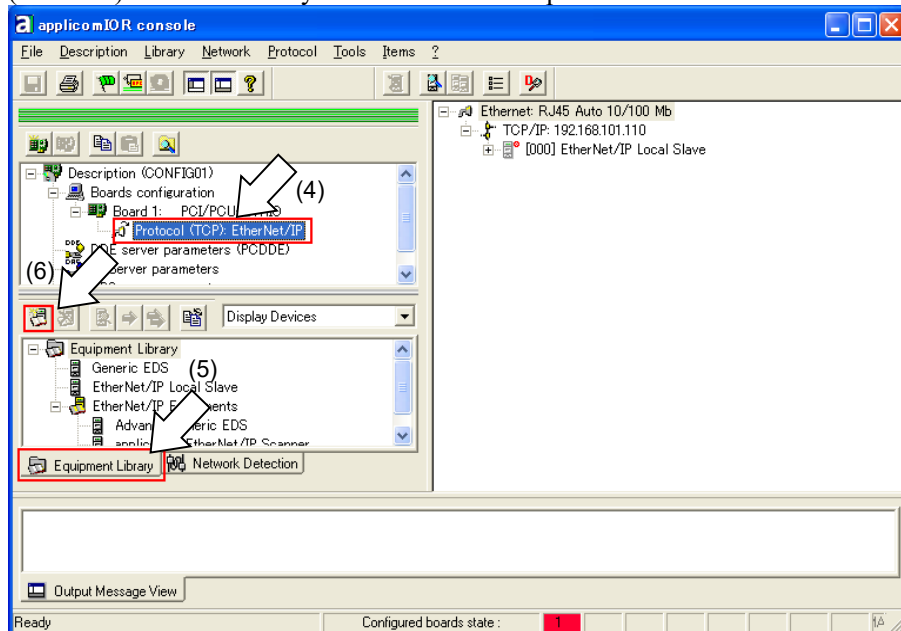

4. Select [Protocol].
5. Select the [Equipment Library] tab.
6. Click [Add].

- The [EDS Management] dialog box appears. Register the EDS file that is supplied from the device manufacturer in the Robot system. Click [Next].

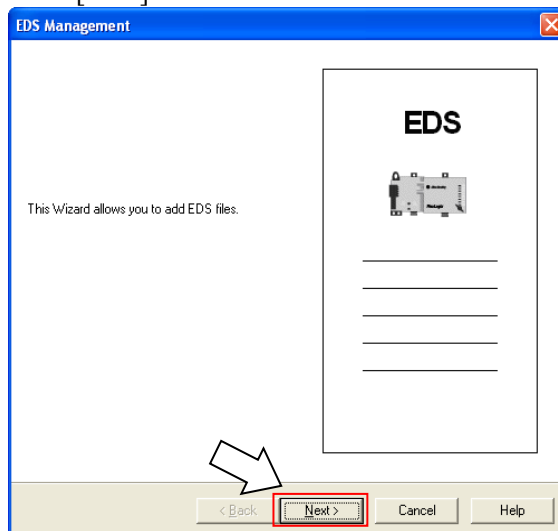

- The following dialog box appears. Specify the folder in which the EDS file is stored. Select [Add all the EDS from the Directory].

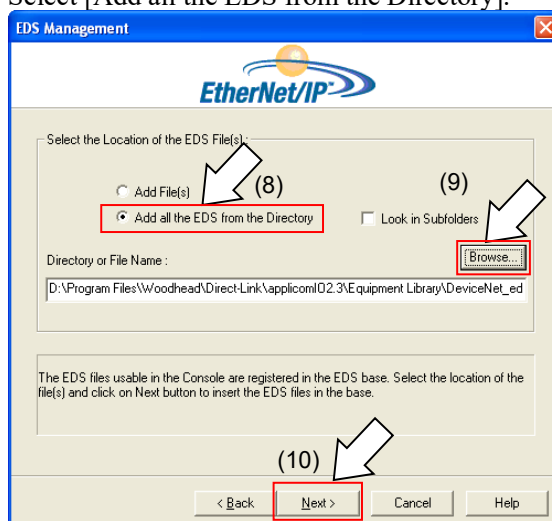

- Click [Browse].
- Click [Next].

11. The following dialog box appears. Confirm the retrieved device information.

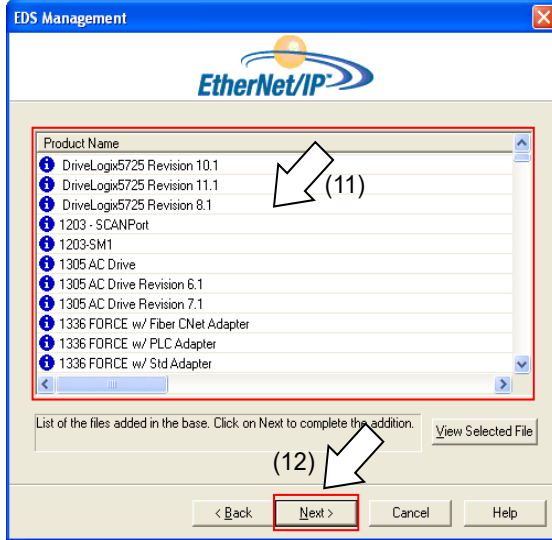

12. Click [Next].
13. The following dialog box appears. Click [Finish] to complete the EDS file registration.

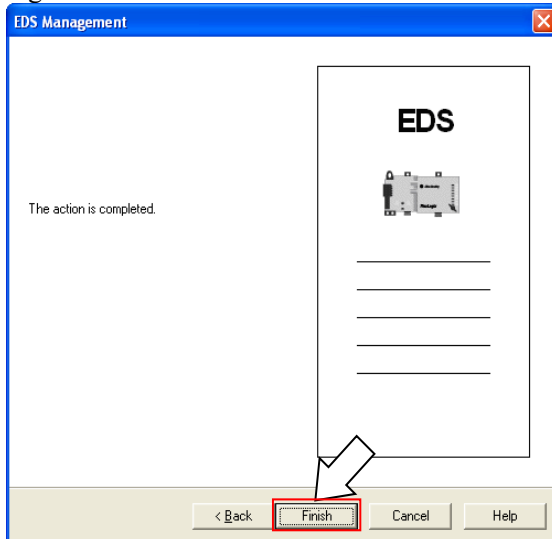

14. Select the [Network Detection] tab.

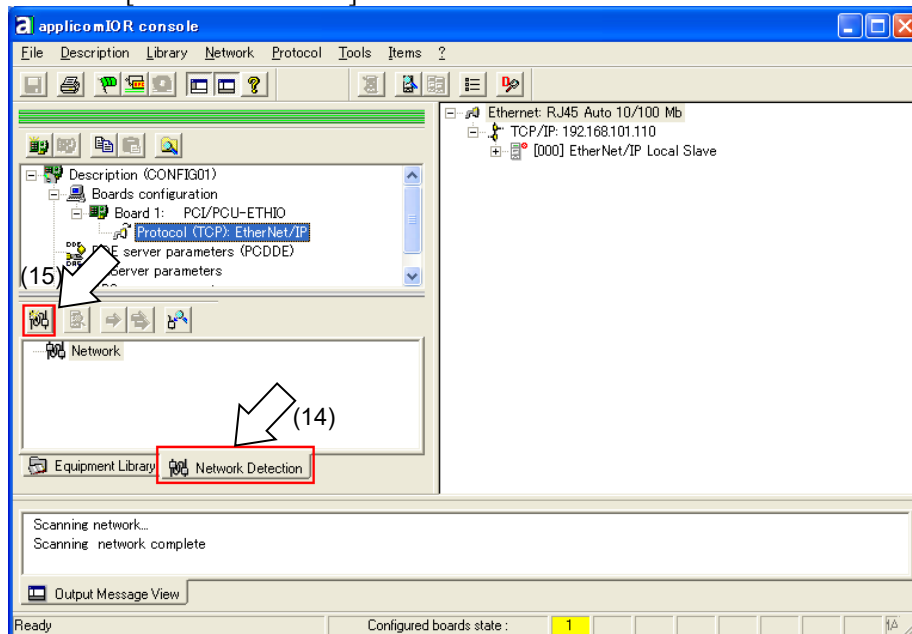

15. Click [Read Network Configuration].
16. The following message appears. Click [Yes].

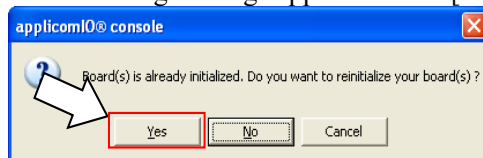

17. Specify the range of detection. If you do not change the range, click [OK].

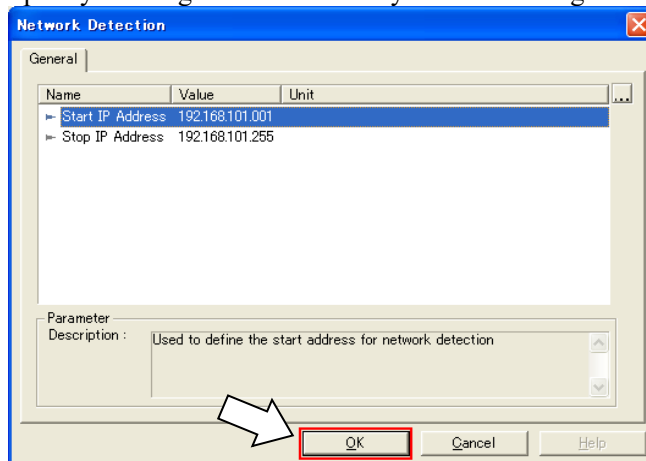

18. The following dialog box appears and read in the devices on the Fieldbus.

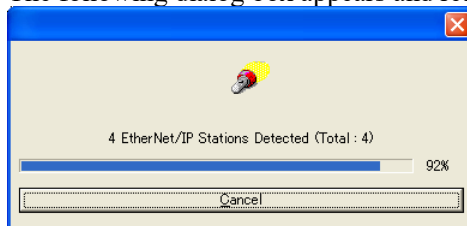

19. The list of detected devices is displayed in the [Network detection] panel.

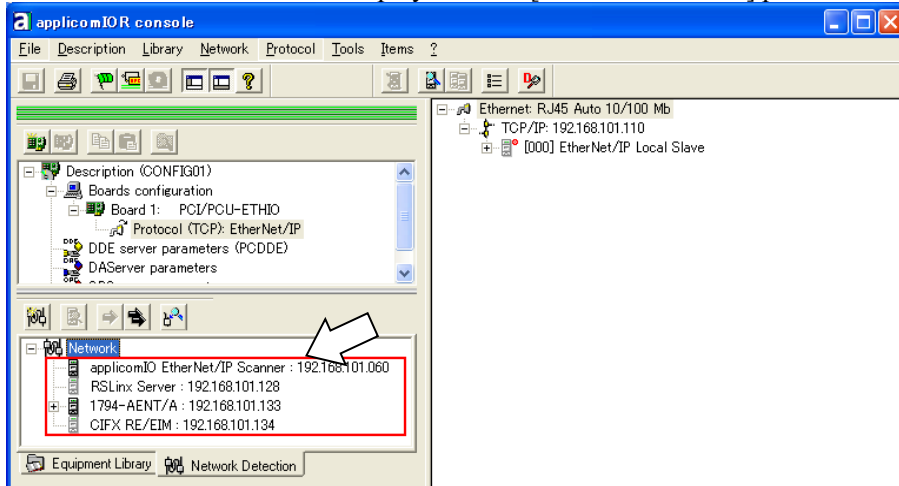

20. Select a device you want to scan.

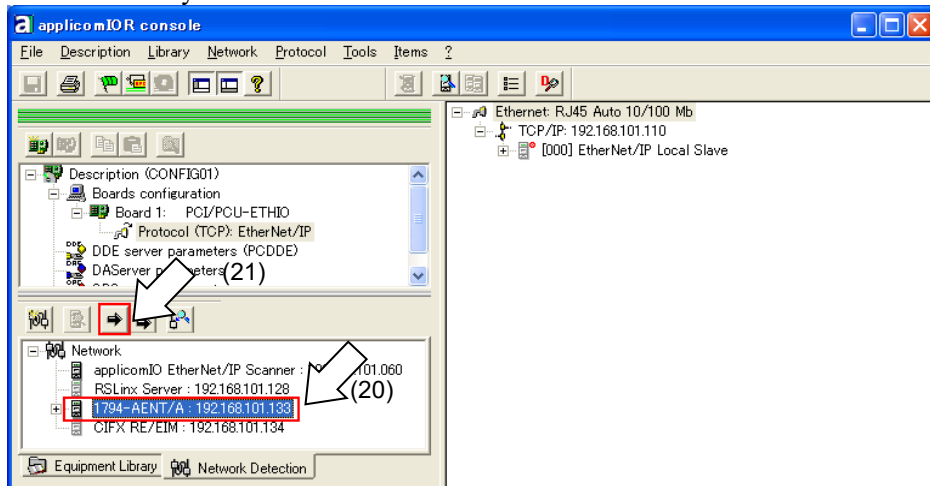

21. Click [Insert in Configuration].
 22. The following dialog box appears. Uncheck the [Link Parameters] checkbox.

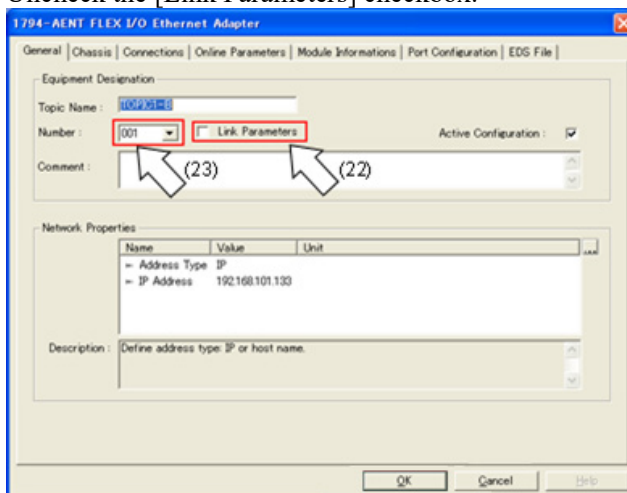

23. Assign a number in the range from 1 to 127 in [Number:]. This number is “Device ID”. It is required when creating a SPEL+ program.

24. Click [General] on [Connections] tab.
Connections Parameters appear to communicate with the slave device.
 - Displayed items are different depending on the slave device.
 - Displayed Connections Parameters are information that is set for the Fieldbus master board.
 Make sure that the information matches with that of the slave device

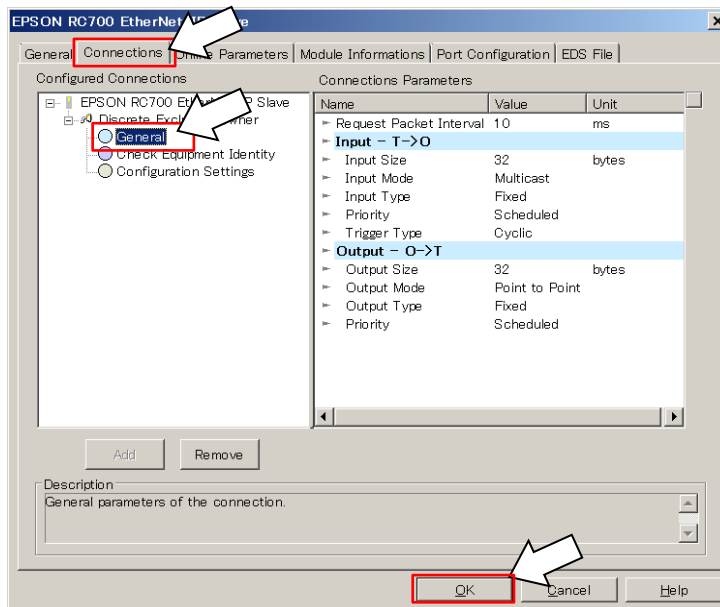

Connections Parameters that are set for the Fieldbus master board and information of the slave device need to be matched.

Communication with the slave device is not performed if they do not match. Change the information of either Connections Parameters or Fieldbus master board. Please consult with the slave device manufacturer if the information is unclear.

- 24-1 Double-click the items to change if necessary.
After changing items, click [OK] button. (The figure below is an example of edit screen of Output Size)

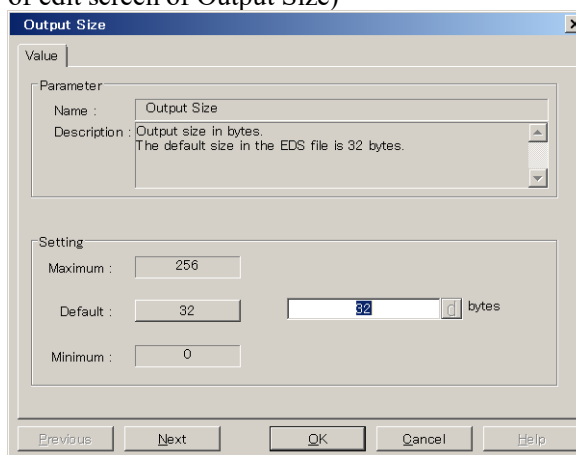

25. Click [OK] to complete the registration.

26. Check the communication status with each slave devices.

Click [Diagnostic].

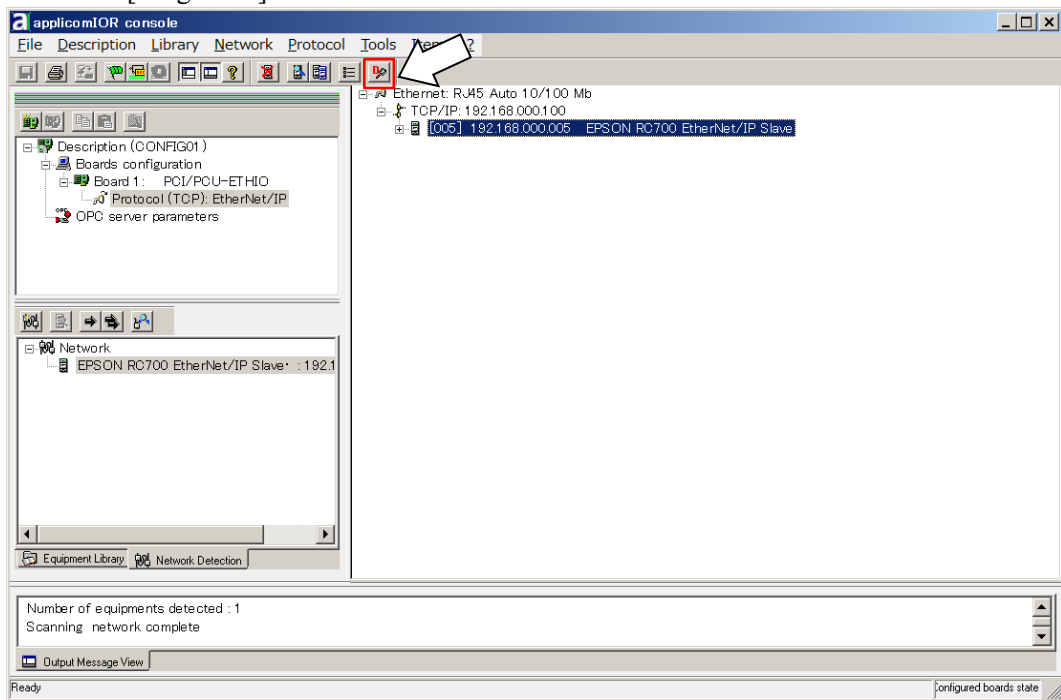

27. The [Diagnostic Board] dialog box is displayed.

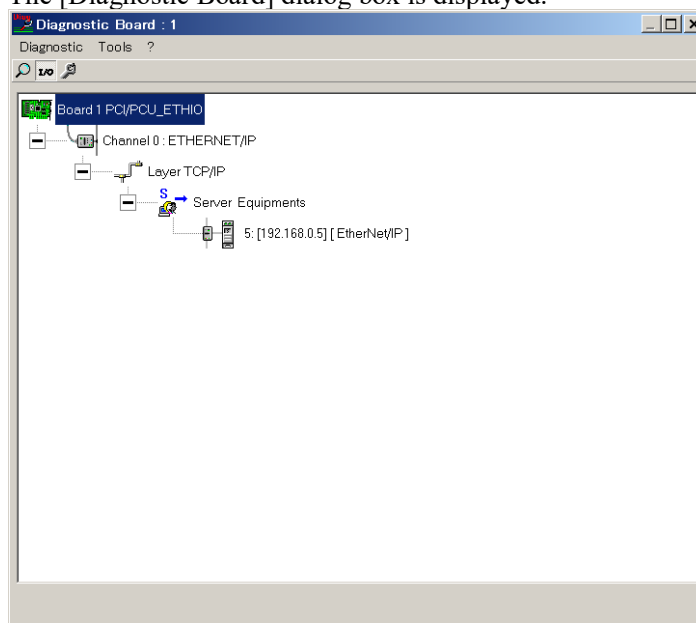

If it cannot communicate with the slave device, the following dialog box appears.

Connections Parameters that are set for the Fieldbus master board and information of the slave device may not be matched.

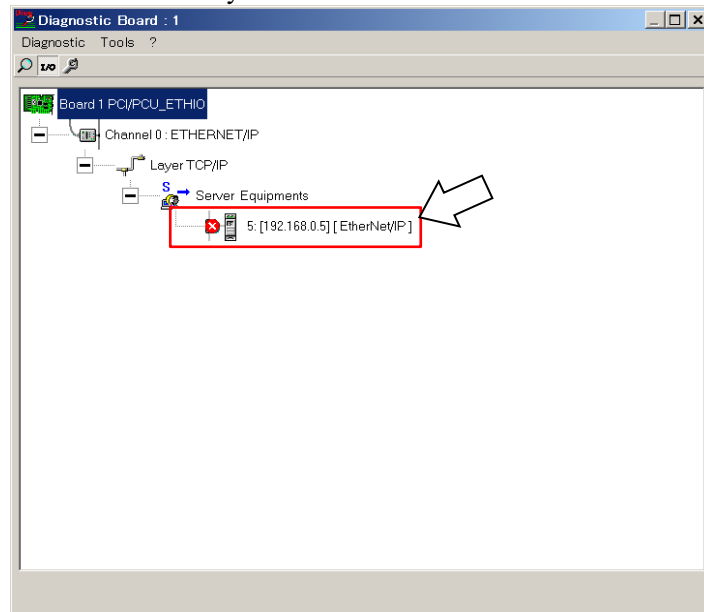

Connections Parameters for the Fieldbus master board can be checked by the following procedure.

First, select the slave device which is registered to the Fieldbus master board.

Then, click the left mouse button and select [Properties].

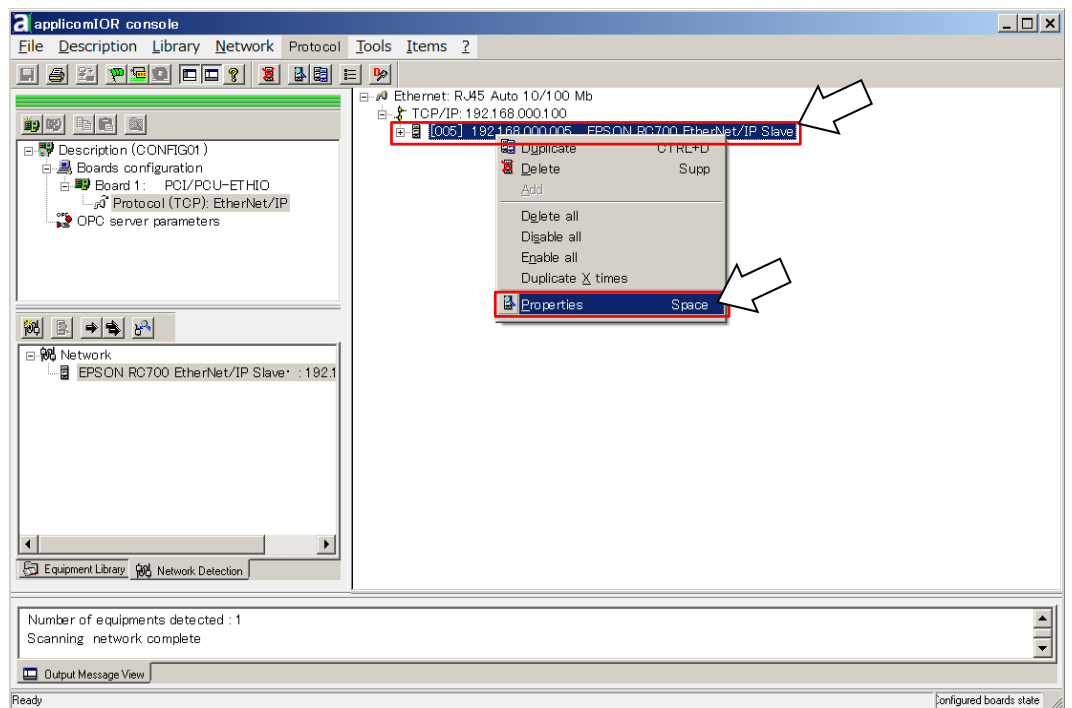

The property information of selected slave device is displayed.

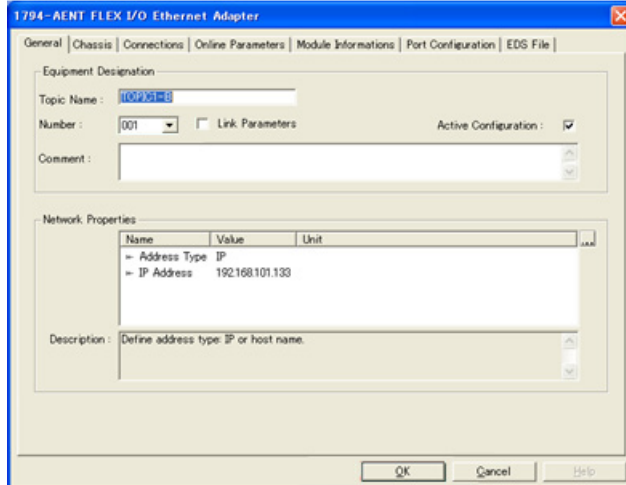

Select [General] on the [Connections] tab.

Connections Parameters appear to communicate with the slave device.

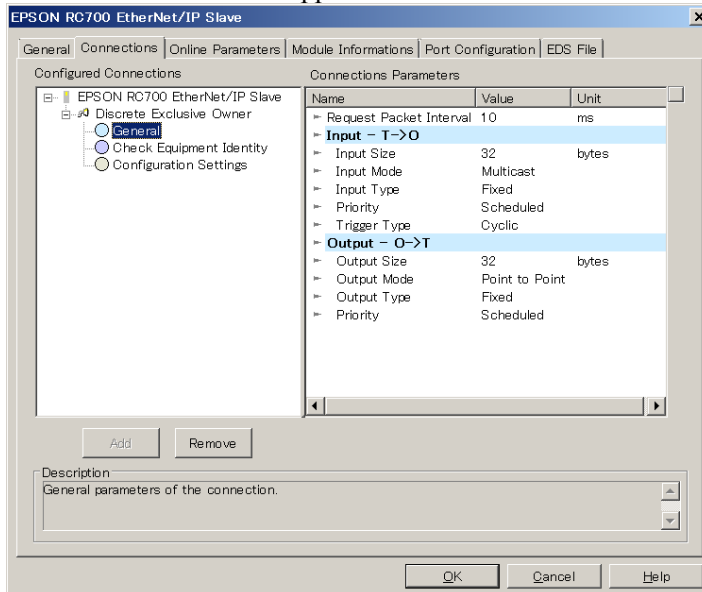

28. Select [File]-[Download in Flash] from the applicomIOR console menu. Register the configuration to the Fieldbus master board.

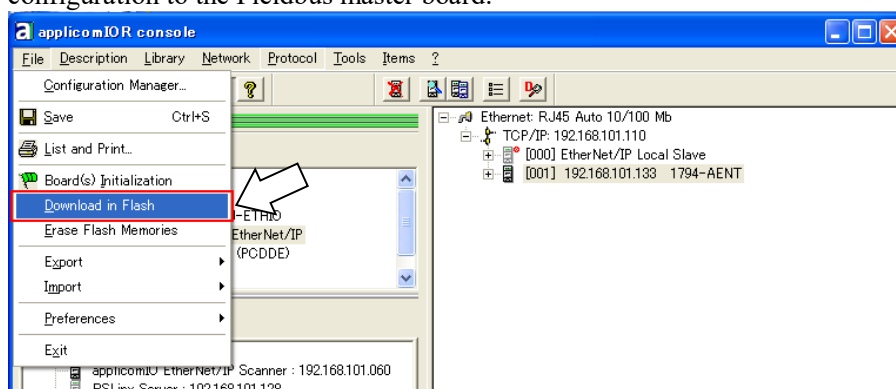

Make sure that the flash memory of Fieldbus master board stores the configuration; otherwise, the Fieldbus master board cannot function correctly. Also, you cannot control it from Epson RC+ 8.0.

If you changed the configuration, select [File]-[Download in Flash] from the applicomIOR console menu and register the configuration to the Fieldbus master board.

29. After a few seconds, the display of “Configured boards state” on the status bar turns to green.

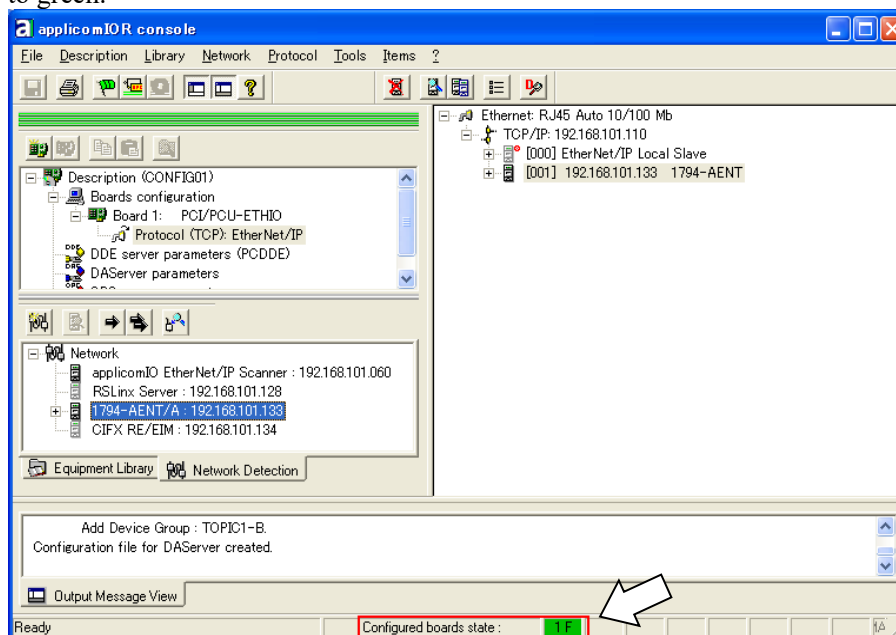

Now, the Fieldbus master board is ready to operate in the master mode.

30. Close the “applicomIO Console” application.
31. Refer to the next section *Epson RC+ 8.0 Configuration* and continue the step.



If there is a problem such as the fieldbus master board is not recognized by Windows, make sure that the combination is described in "Control System Configuration" in the preface of this manual and refer to the following section.

4. Troubleshooting

4.4 How to Disable Fast Startup in Windows

Epson RC+ 8.0 Configuration

To use the Fieldbus master board, the Robot system option setting and Fieldbus master setting should be enabled on Epson RC+ 8.0.

1. Select [Setup]-[License Configuration] and display the [License Configuration] dialog box.
2. Refer to *Epson RC+ User's Guide: Installing Controller Licenses* and enable the Fieldbus Master option.
3. When the following message displays, click the [OK] button.

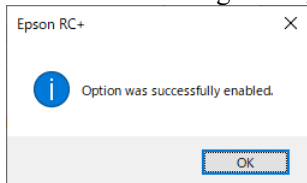

4. Select [Setup]-[System Configuration] and display the [System Configuration] dialog box.
5. Select [Controller]-[Inputs/Outputs]-[Fieldbus Master]-[General].

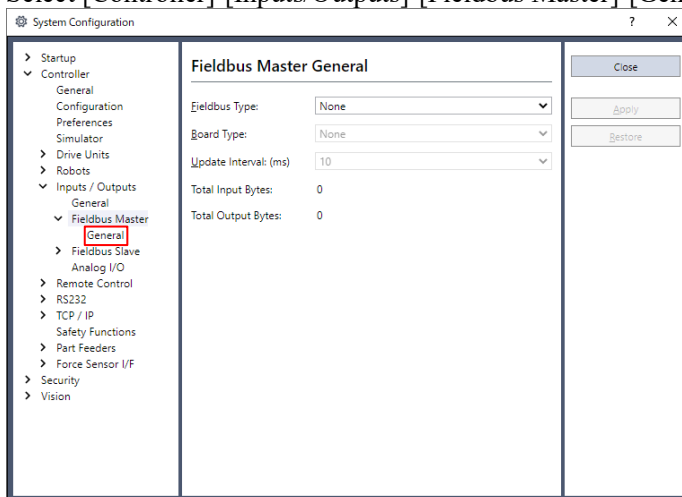

6. Set the following items:
 [Fieldbus Type:] EtherNet/IP
 [Board Type:] Molex
 [Update Interval:] Update cycle for the EtherNet/IP master I/O

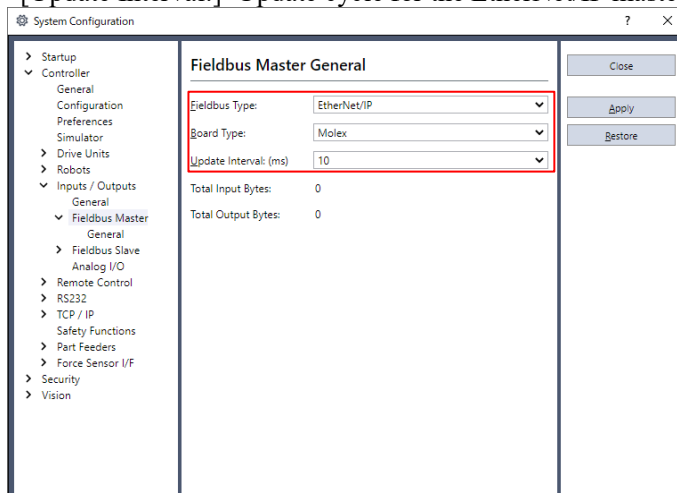

7. Click [Apply].
 Confirm that the following items are displayed.
 Total Input Bytes : Number of inputs the master controls (Bytes)

Total Output Bytes : Number of outputs the master controls (Bytes)

8. Click [Close].
The following dialog box appears and the Controller automatically starts rebooting.

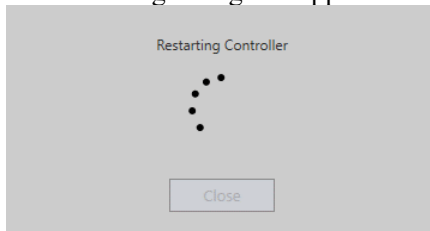

9. Select [Setup]-[System Configuration] and display the [System Configuration] dialog box.
10. Select [Controller]-[Inputs / Outputs].

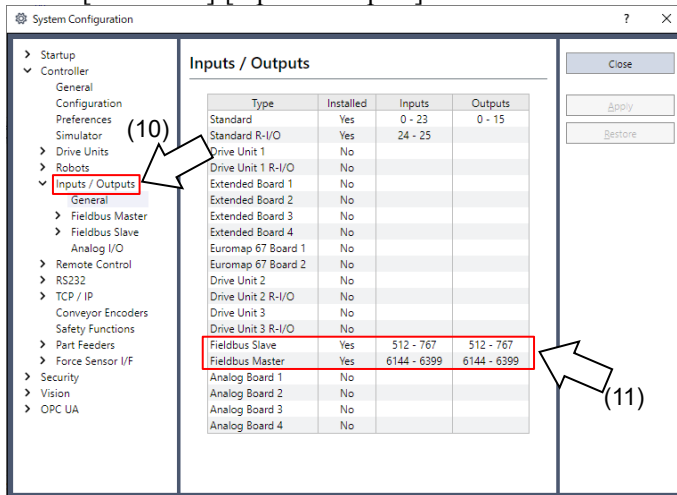

11. Confirm that the following items are displayed in "Fieldbus Master".

Installed : Yes

Inputs : 6144 – (6144 + Number of inputs the master controls (Bits))

Outputs : 6144 – (6144 + Number of outputs the master controls (Bits))

12. Select [Fieldbus Master]-[General].

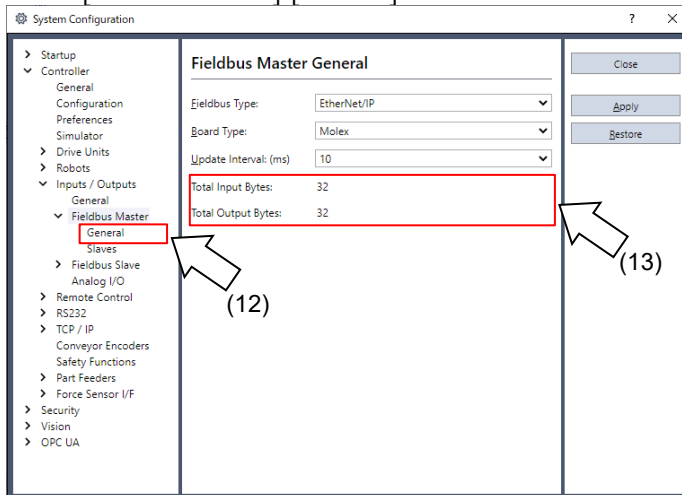

13. Confirm that the following items are displayed.

Total Input Bytes : Number of inputs the master controls (Bytes)

Total Output Bytes : Number of outputs the master controls (Bytes)

14. Select [Fieldbus Master]-[Slaves].

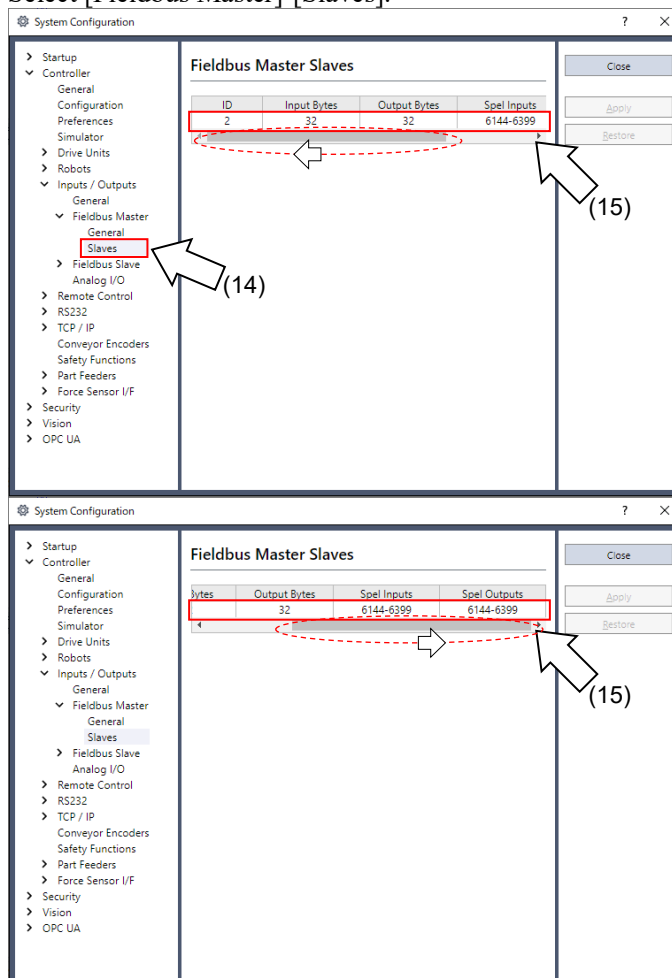

15. Confirm that the following information the master controls are displayed.

- ID : Fieldbus station ID of slave
- Input Bytes : Number of inputs per slave (Bytes)
- Output Bytes : Number of outputs per slave (Bytes)
- Spel Inputs : Number of inputs per slave (Bits)
- Spel Outputs : Number of outputs per slave (Bits)

“Encapsulation Inactivity Timeout”

Fieldbus EtherNet/IP master board manufactured by moxex is not supported “Encapsulation Inactivity Timeout” which is added by EtherNet/IP standard update. If connecting the EtherNet/IP slave device that supports “Encapsulation Inactivity Timeout”, connection will be disconnected due to inconsistency with standard update on the above.

You need to change the set value of “Encapsulation Inactivity Timeout” on the Fieldbus EtherNet/IP master board side.

How to Change the Set Value on the Master Side

Set “0x0000” of UINT below.

TCP/IP Interface Object (F5h) class - Instance #1 - Attribute#13
- Encapsulation Inactivity Timeout

Describe the procedures to set on applicomIO 4.2 Console application.

1. Connect the fieldbus master and the slave.
2. Select [Network]-[Online Action] on the menu of the [applicomIO Console] application.
3. The [Outline Action] dialog box appears. Select the [Explicit Message] tab.

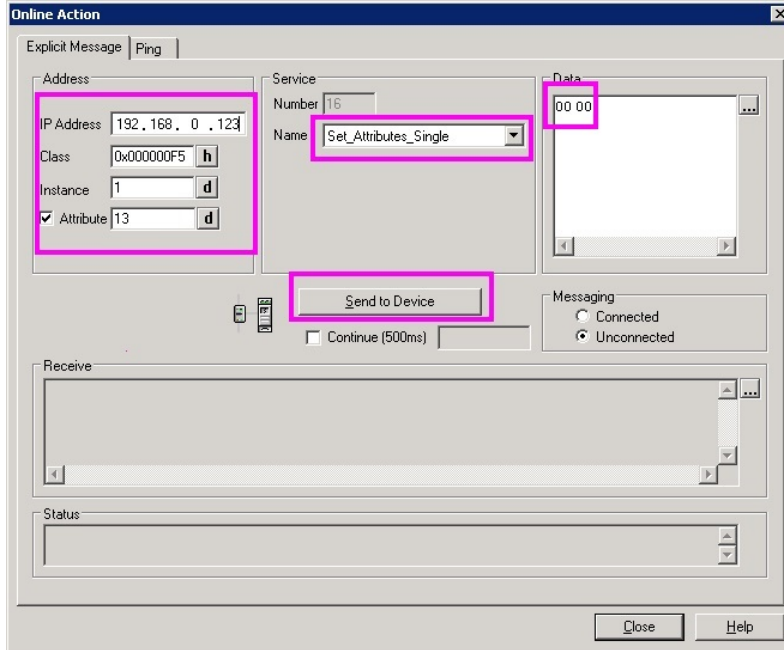

Set as follows:

Address

IP Address : IP address of the fieldbus EtherNet/IP slave
Class : 0x000000F5
Instance : 1
Attribute : 13

Service

Name : Set_Attribute_Single
Data : 0000

4. Click [Send to Device].
5. Confirm that the “CIP Status: 0x0. Success” is displayed on the [Status].

Now, changing the setting is complete.

2.3.4 Installing EtherNet/IP Board Manufactured by Hilscher

Appearance

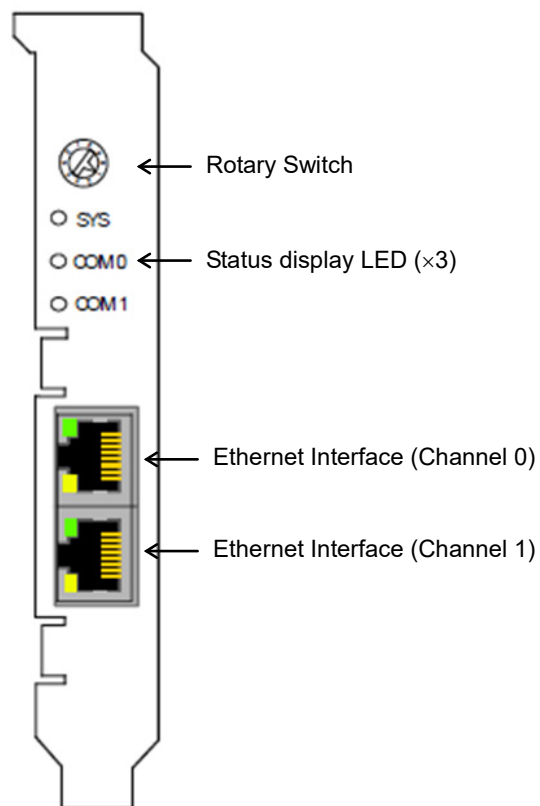

PCI: CIFX 50-RE

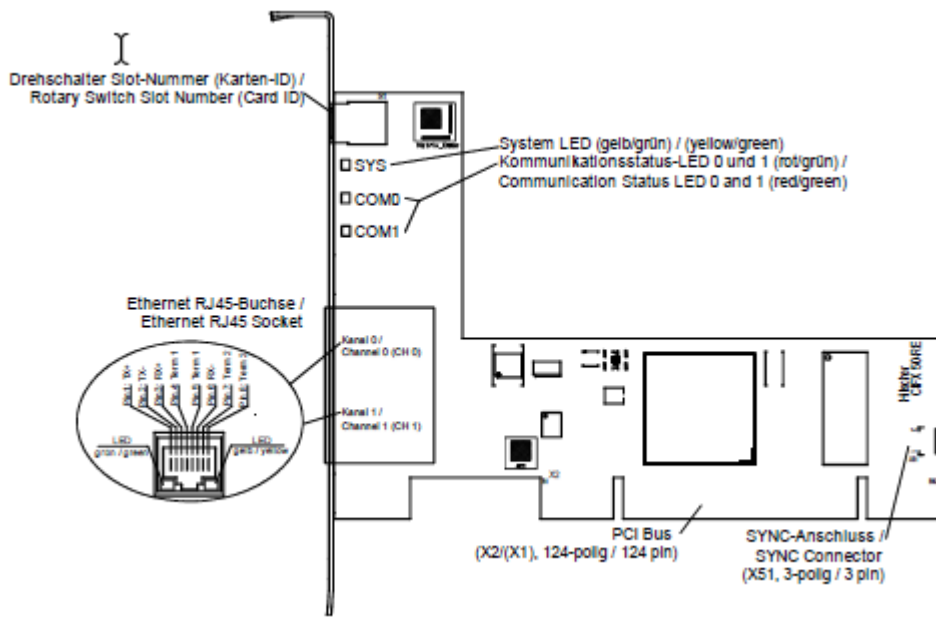

PCI Express: CIFX 50E-RE

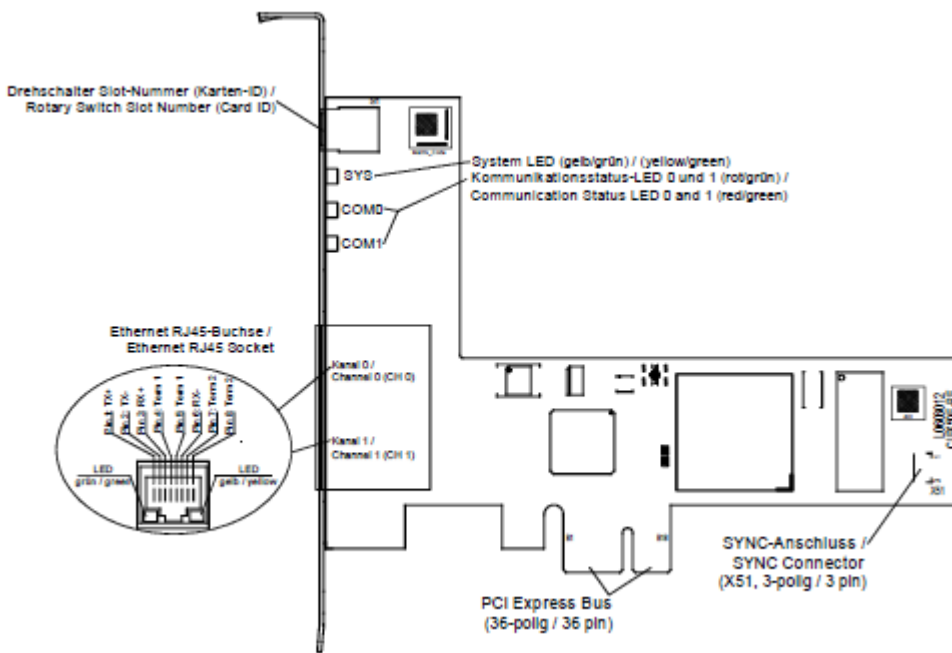













Specifications

EtherNet/IP Scanner

Item	Specification
Name	EtherNet/IP board manufactured by Hilscher
Maximum number of EtherNet/IP connections	64 connections for implicit and explicit
Maximum number of total cyclic input data	5712 bytes
Maximum number of total cyclic output data	5760 bytes
Maximum number of cyclic input data	128 bytes per slave per telegram
Maximum number of cyclic output data	128 bytes per slave per telegram
IO connection type	Cyclic, minimum 1 ms (depending on used number of connections and used number of input and output data)
Maximum number of unscheduled data	1400 bytes per telegram
UCMM, Class 3	Supported
Explicit Messages, Client and Server Services	Get_Attribute_Single/All Set_Attribute_Single/All
Quick connect	Supported
Predefined standard objects	Identity Object Message Route Object Assembly Object Connection Manager Ethernet Link Object TCP/IP Object DLR Object QoS Object
Maximal number of user specific objects	20
Network scan	Supported
Topology	Tree, Line, Ring
DLR (Device Level Ring)	Beacon based "Ring Node"
ACD (Address Conflict Detection)	Supported
DHCP	Supported
BOOTP	Supported
Baud rates (bps)	10M, 100 M
Data transport layer	Ethernet II, IEEE 802.3
Switch function	Integrated
Limitations	CIP Sync Services are not implemented, TAGs are not supported.
Reference to firmware/stack version	V2.9

LED Description

For the EtherNet/IP scanner protocol, the communication LEDs MS and NS as well as the Ethernet LEDs LINK and ACT can assume the state described below.

LED	Color	State	Description
MS (Module Status) General name: COM 0	Duo LED red/green		
	 (green)	ON	Device operational: The device is operating correctly.
	 (green)	Flashing (1 Hz)	Standby: The device has not been configured.
		Flashing (green, red, green)	Self-test: The device is performing its power-up testing.
	 (red)	Blinking (1 Hz)	Major recoverable fault: The device has detected major recoverable fault. E.g. an incorrect or inconsistent configuration can be considered a major recoverable fault.
	 (red)	ON	Major unrecoverable fault: The device has detected a major unrecoverable fault.
	 (OFF)	OFF	No power: The device is powered OFF.
NS (Network status) General name: : COM 1	Duo LED red/green		
	 (green)	ON	Connected: An IP address is configured, at least one CIP connection (any transport class) is established. Exclusive Owner connection has not timed out.
	 (green)	Flashing (1 Hz)	No connections: An IP address is configured, but no CIP connections are established. Exclusive Owner connection has not timed out.
		Flashing (red, green, OFF)	Self-test: The device is performing its power-up testing.
	 (red)	Blinking (1 Hz)	Connection timeout: An IP address is configured, and Exclusive Owner connection for which this device is the target has timed out. The NS indicator returns to steady green only when all timed out Exclusive Owner connections are reestablished.
	 (red)	ON	Duplicate IP: The device has detected that its IP address is already in use.
 (OFF)	OFF	Not powered, no IP address: The device does not have an IP address. (Or is powered OFF).	

LED	Color	State	Description
LINK Ch0 & Ch1	LED green		
	● (green)	ON	The device is linked to the Ethernet.
	● (OFF)	OFF	The device has no link to Ethernet.
ACT Ch0 & Ch1	LED yellow		
	☀ (yellow)	Flickering (load dependent)	The device sends/receives Ethernet frames.
	● (OFF)	OFF	The device does not send/receive Ethernet frame.

LED state	Description
Blinking (1 Hz)	The indicator turns ON and OFF with a frequency of 1 Hz. Turn ON for 500 ms, followed turn OFF for 500 ms.
Flickering (load dependent)	The indicator turns ON and OFF with a frequency of approx. 10Hz to indicate high Ethernet activity. Turn ON for approx. 50 ms, followed turn OFF for 50 ms. The indicator turns ON and OFF in irregular intervals to indicate low Ethernet activity.

Modes

EtherNet/IP board manufactured by Hilscher has the master mode and the slave mode. However, do not use in the slave mode.

Master mode

The master device gathers and controls all nodes on EtherNet/IP network.

EtherNet/IP master can control up to 64 nodes (max. 128 bytes per slave) in one network.

PLC is typically configured as a master and controls all nodes in factory automation system, but Epson RC+ is also capable of being a master.

EtherNet/IP network configuration is specified by configuration management software. This is normally provided by a master device manufacturer.

The configuration management software determines parameters for each slave device via an Electronic Data Sheet (EDS).

Available connection types are Cyclic, Change of State, and Explicit Messaging.

Available baud rates are 100 Mbps and 10 Mbps.

Installing Software

Installing device driver

Before adding EtherNet/IP board manufactured by Hilscher to the PC with the Epson RC+ 8.0 installed, you must install the Hilscher SYCON.net application and drivers according to the type of the board you are using.

1. Insert Communication-Solutions DVD into the PC with Epson RC+ 8.0 installed.
2. Open the [Communication-Solutions DVD \Driver_&_Toolkit\Device Driver (NXDRV-WIN)\Installation] folder of Communication-Solutions DVD. Execute cifX Device Driver Setup.exe.
3. The [User Account Control] dialog box appears. Click [Yes].



4. The [Device Driver Setup] dialog box appears. Select the [I accept the terms in the License Agreement] check box. Click [Install].

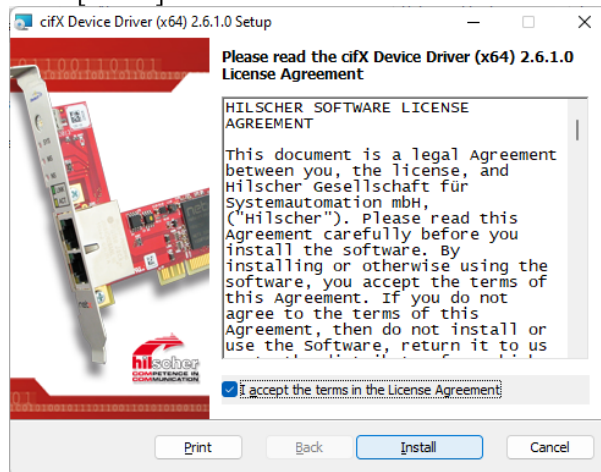

5. The [Windows Security] dialog box appears. Click [Install].
6. When the dialog box switched, click [Install] again.

7. The [Completed the cifX Device Driver (x64) 2.6.1.0 Setup Wizard] dialog box appears.
Click [Finish].



Installing master application software

1. Open the [Communication-Solutions DVD \ Software_ & Tools\ Configuration_ Software\ SYCON.net] folder of Communication-Solutions DVD.
Execute SYCONnet netX setup.exe.
2. When Windows Security Alert appears, do not click [Cancel] and proceed to the next step.
3. The [User Account Control] dialog box appears.
Click [Yes].

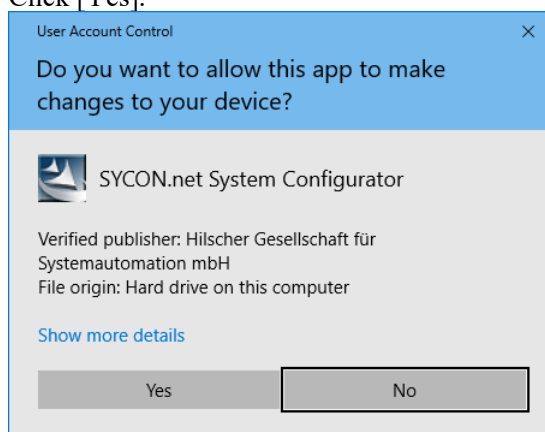

4. The [Choose Setup Language] dialog box appears.
Select “English [USA]” and click [OK].

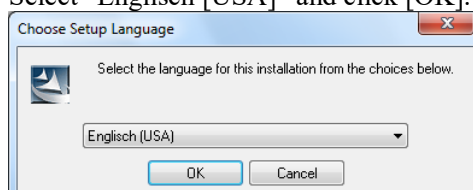

Now, start the installation.

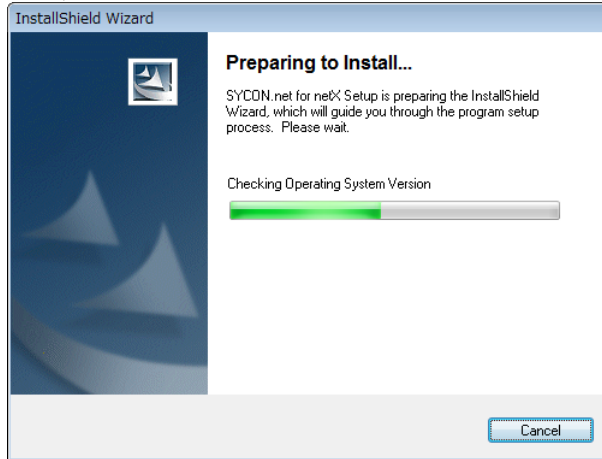

- 5. The [InstallShield Wizard - Welcome] dialog box appears. Click [Next].

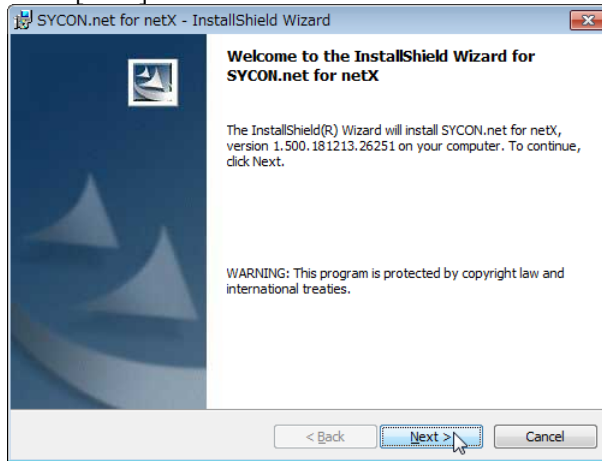

- 6. [InstallShield Wizard - Important Information] dialog box appears. Select [I read the information]. Click [Next].

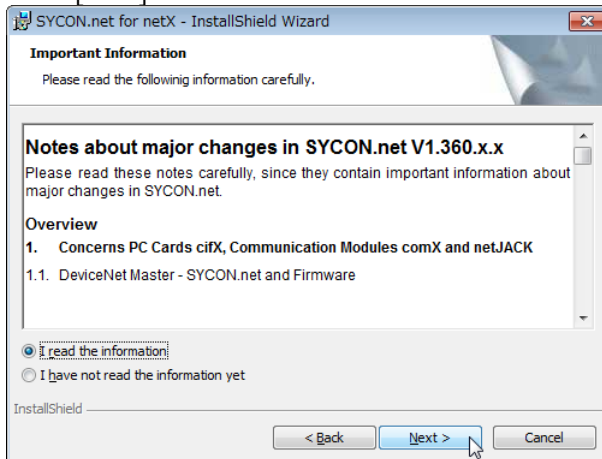

7. The [InstallShield Wizard - License Agreement] dialog box appears. Select [I accept the terms in the license agreement]. Click [Next].

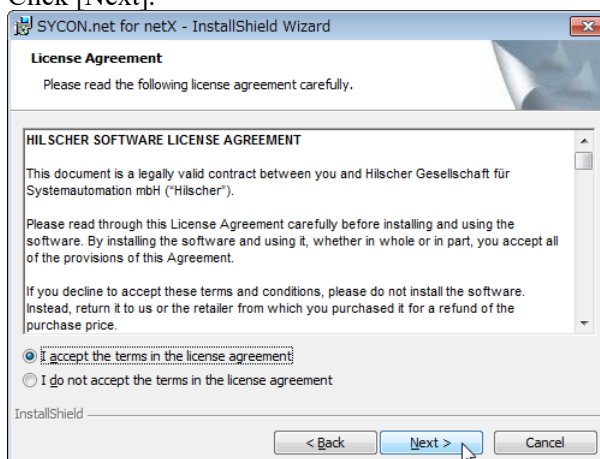

8. The [InstallShield Wizard - Customer Information] dialog box appears. Enter the User Name and Organization. Click [Next].

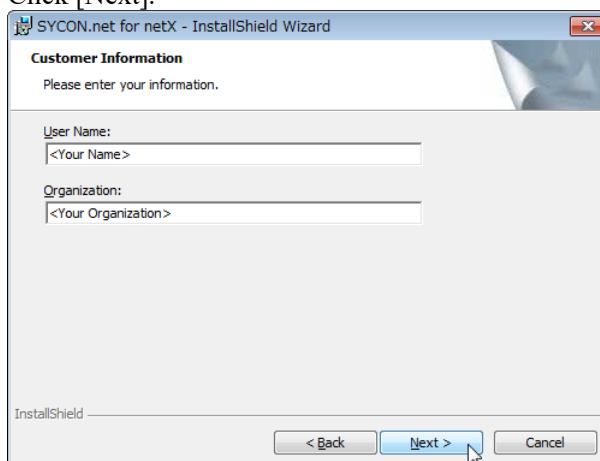

9. The [InstallShield Wizard - Ready to Install the Program] dialog box appears. Click [Install].

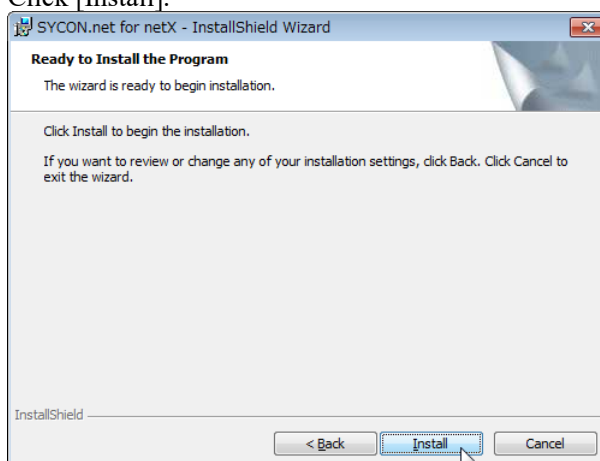

Now, start the installation.

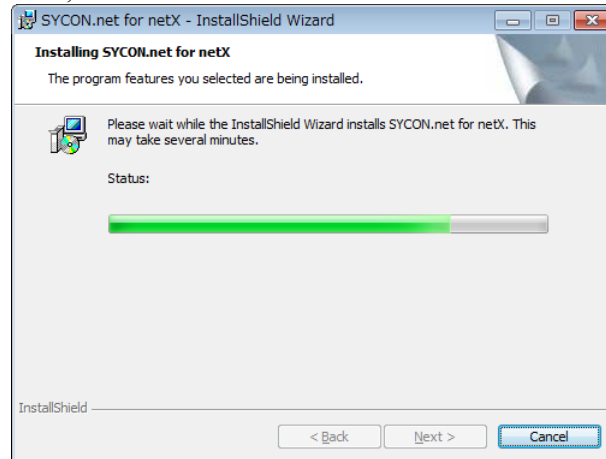

10. The [InstallShield Wizard - InstallShield Wizard Completed] dialog box appears. Click [Finish].

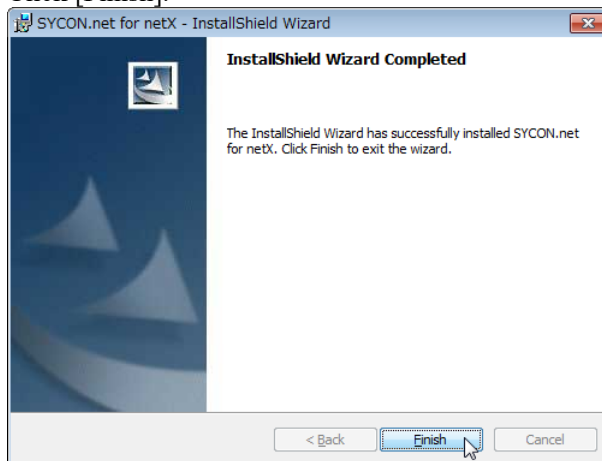

Refer to the next *Installing a Board* to install EtherNet/IP board manufactured by Hilscher.

Installing a Board

1. Configure the rotary switch of the board address on EtherNet/IP board manufactured by Hilscher.
You can install one Fieldbus master board to the PC with Epson RC+ 8.0 installed. The slot number should be “Not in use (0)”. Refer to the following table for configuration.

Slot No.	Rotary switch position
Not in use	0
Slot No. 1	1
Slot No. 9	9

2. Install the EtherNet/IP board manufactured by Hilscher to the PCI bus or PCI Express bus of the PC with Epson RC+ 8.0 installed.
Installation methods of the EtherNet/IP board manufactured by Hilscher to the PCI bus/PCI Express bus and how to open the cover differ depending on the type of PC. Refer to the manuals of each PC on how to install the board to the PCI bus/PCI Express board.
3. Connect EtherNet/IP board manufactured by Hilscher with the EtherNet/IP network.

4. Describe an example to set the master and the slave as the setting below.

Setting item	Value
Address configuration	Fixed address
Master IP address	192.168.0.2
Slave IP address	192.168.0.3
Subnet mask	255.255.255.0
Input Bytes	32
Output Bytes	32

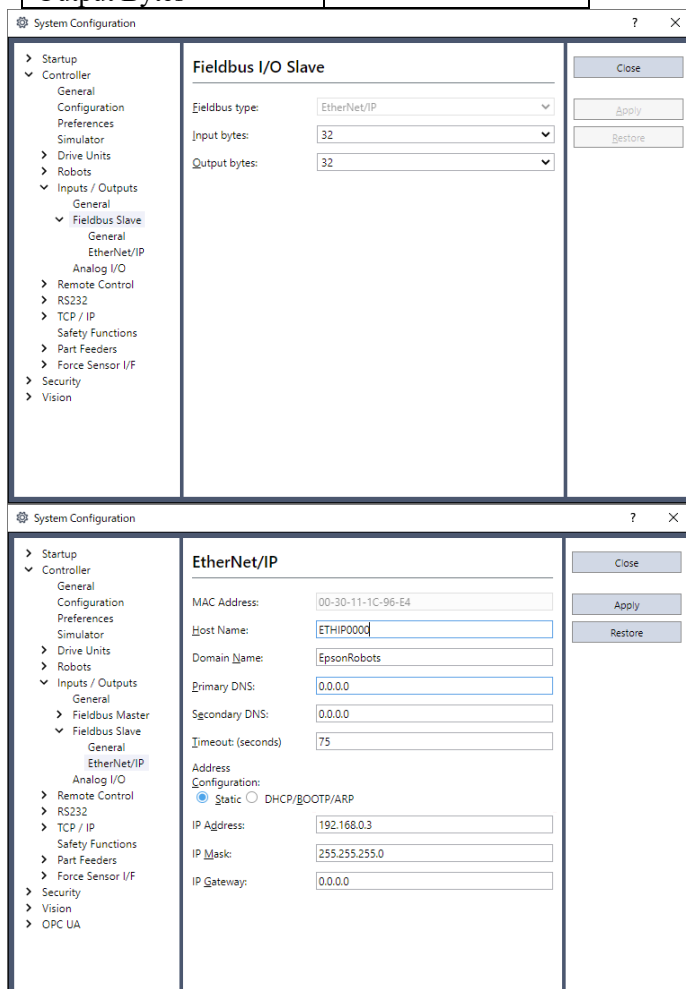

5. Start up the PC.
6. Select the Start menu-[SYCON.net] and execute it.

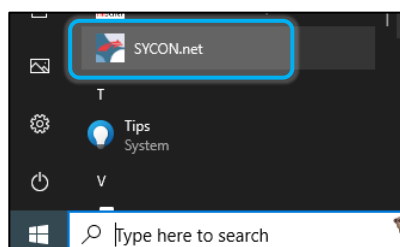

7. Set a Confirm password of SYCON.net.
Click [OK].
Be careful not to forget the Confirm password.

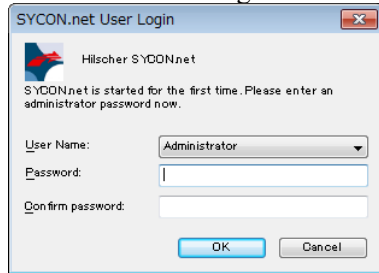

8. SYCON.net starts up.
Click [netDevice]-Device Catalog list on the right side-[CIFX RE/EIM].

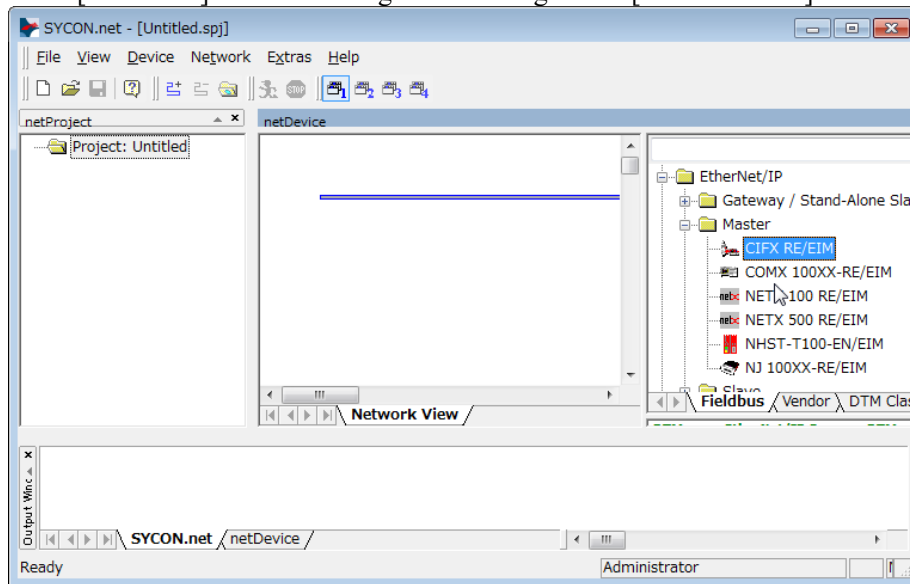

Importing slave EDS files

9. Click [Network]-[Import Device Descriptions...].

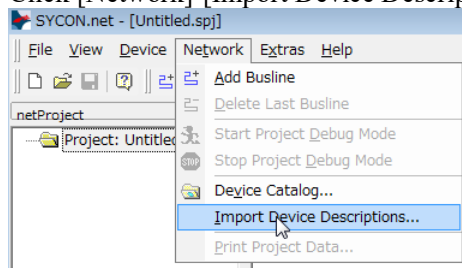

10. [Import Device Description] dialog box appears.
From [Files of type], select "DeviceNet EDS."
Select EDS files provided by each device manufacturer and click [Open].

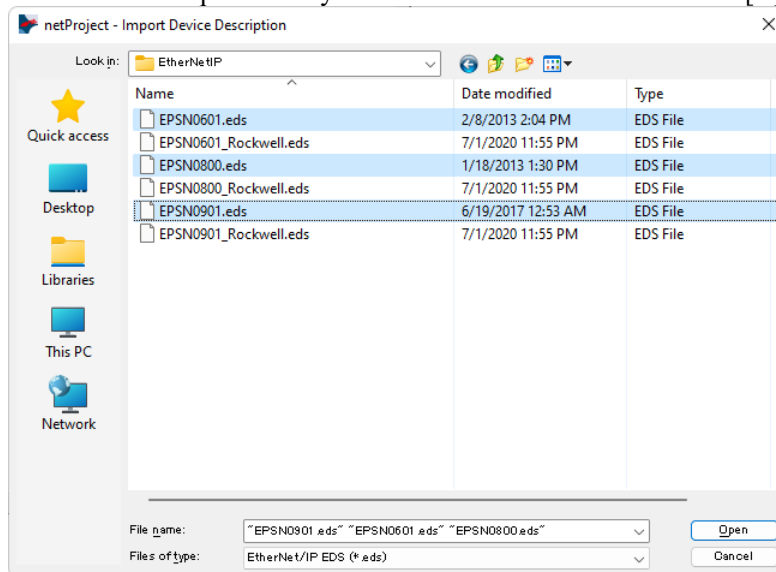

11. The following message appears.
Click [Yes]. EDS files are imported.

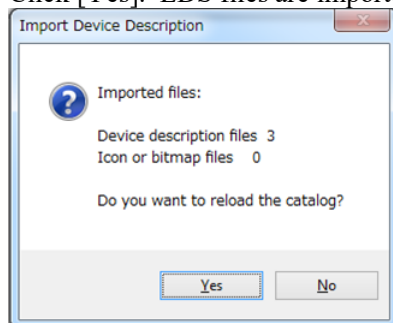

Adding a master icon

- 12. Click SYCON.net application software-[netDevice]-Device Catalog list on the right side-[EtherNet/IP]-[Master]-[CIFX RE/EIM].

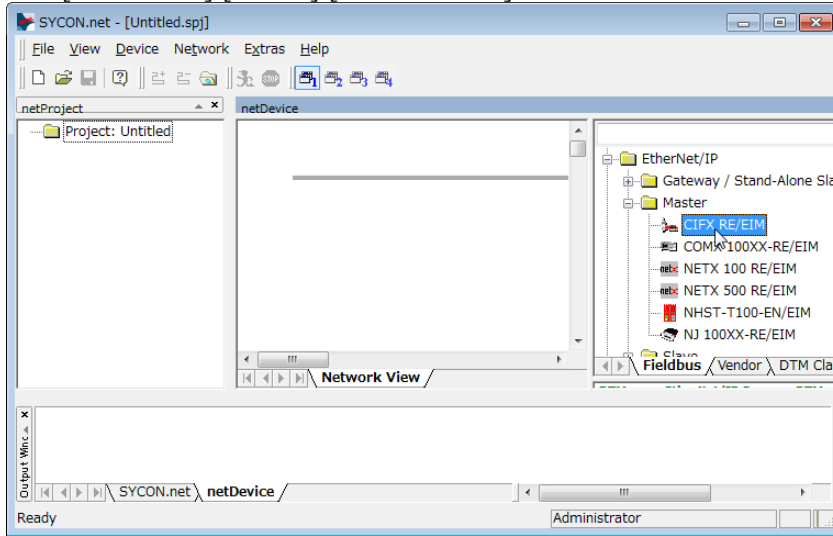

- 13. Drag & drop [CIFX RE/EIM] on the bold line on the left side of [netDevice].

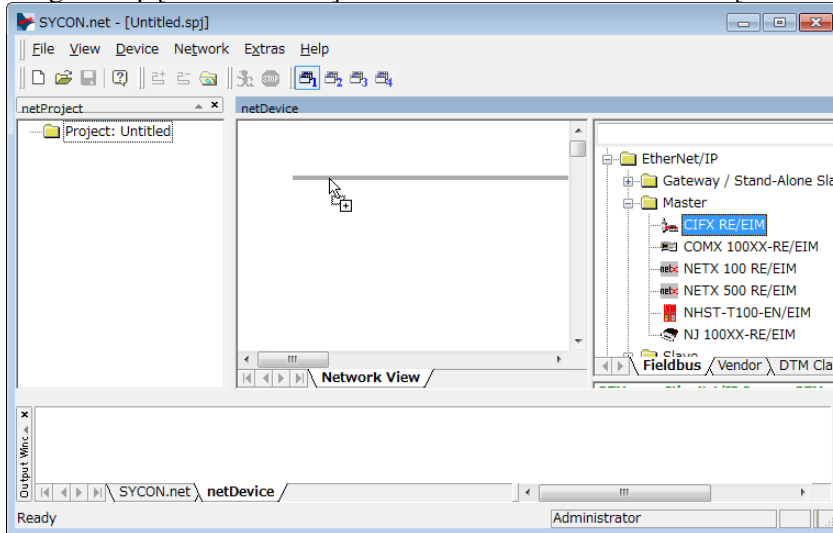

- 14. The “CIFX_RE_EIM” icon indicating EtherNet/IP board manufactured by Hilscher is connected.

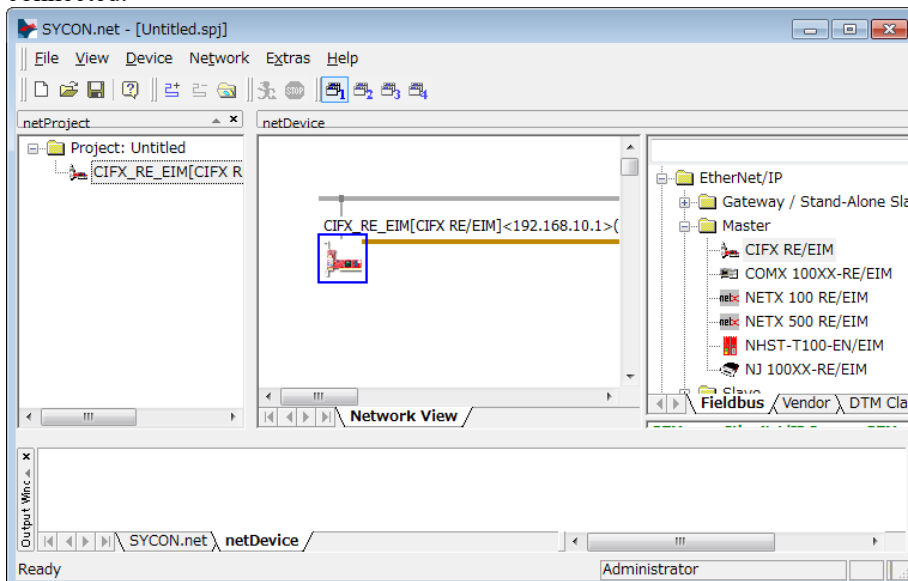

Adding a slave icon

- Click SYCON.net application software-[netDevice]-Device Catalog list on the right side-[EtherNet/IP]-[Slave]-Slave device.

In case of EtherNet/IP slave module:

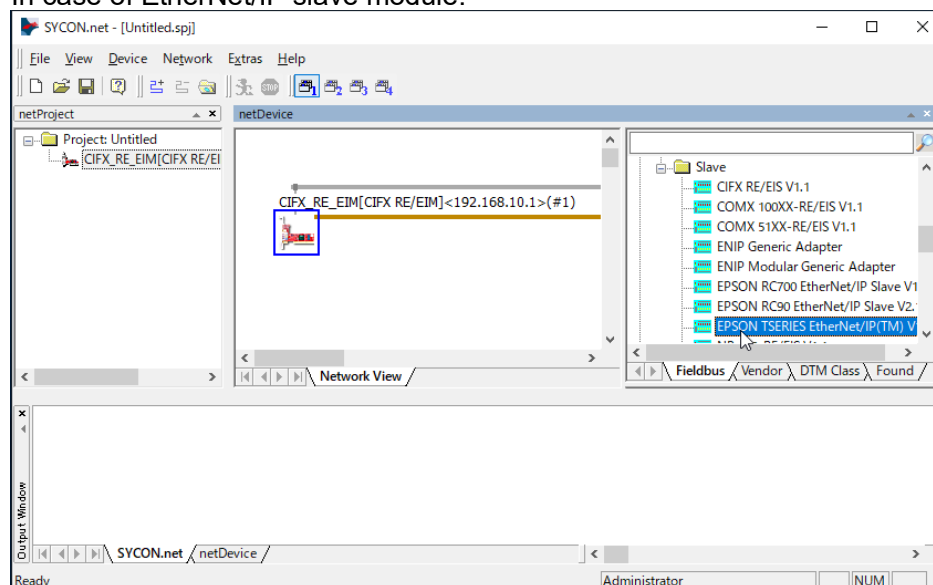

- Drag & drop the selected slave device on the bold line on the left side of [netDevice].

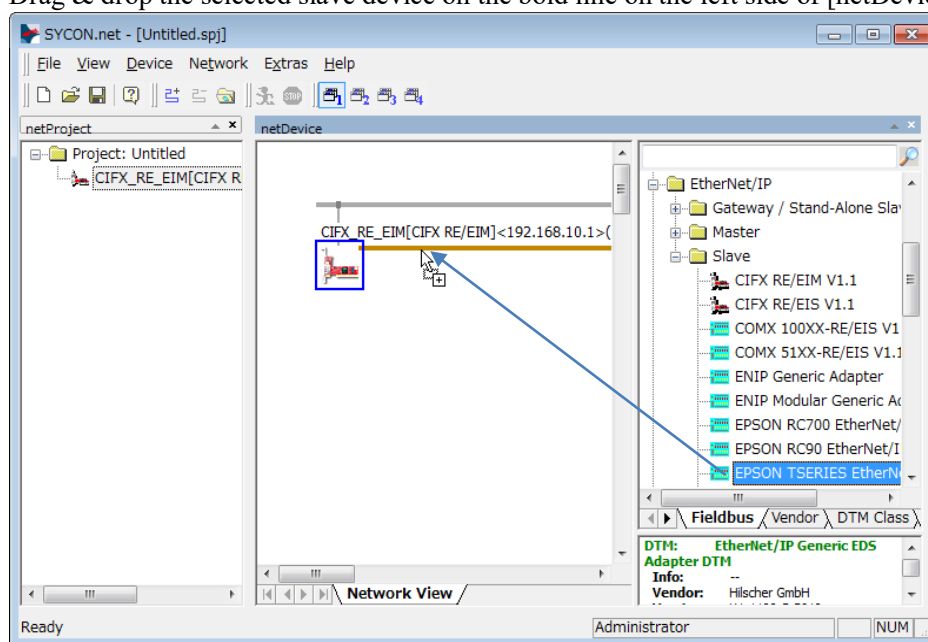

17. EtherNet/IP Slave is connected and the icon appears.

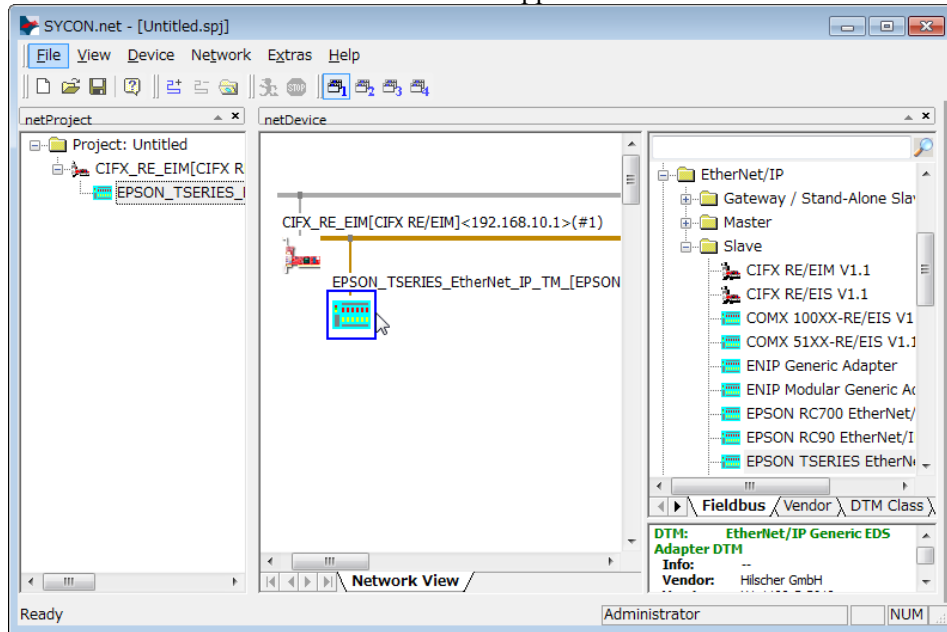

Setting on master side

18. Right-click [netDevice]-[CIFX_RE_EIM] and click [Configuration...].

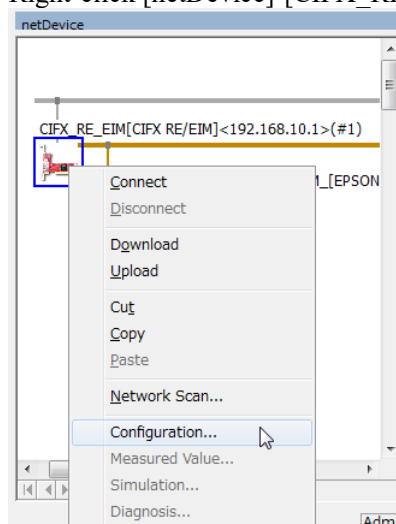

19. The [Configuration] dialog box appears.

Select [Settings]-[Driver] tab.

Select the [CIFX Device Driver] checkbox and click [Apply].

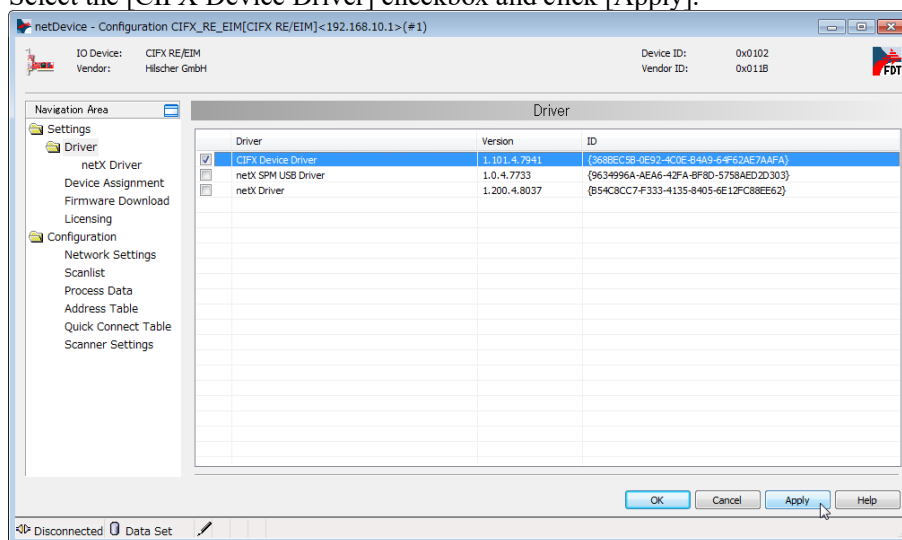

20. Select [Settings]-[Device Assignment].

21. Select the [CIFX 50E-RE] checkbox.
Click [Apply].

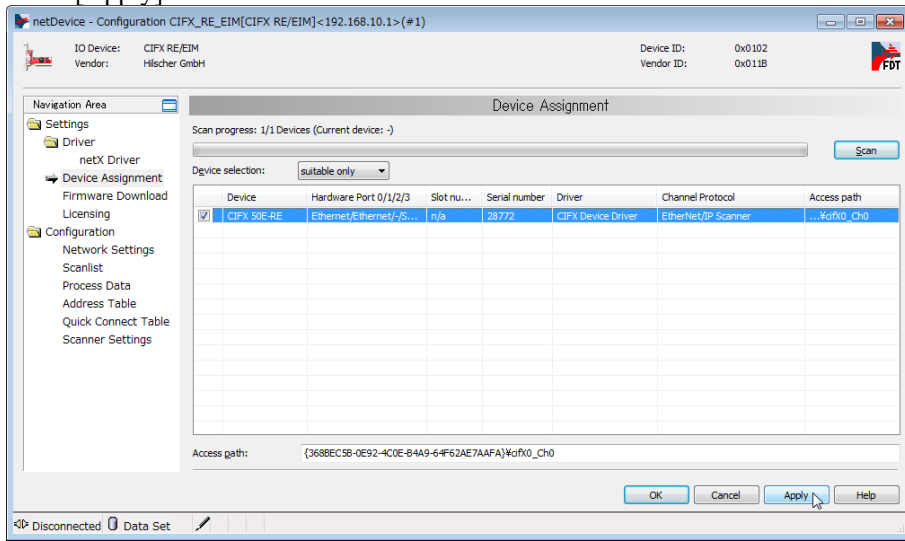

22. Select [Settings]-[Driver]-[Firmware Download] tab.
Click [Browse...].

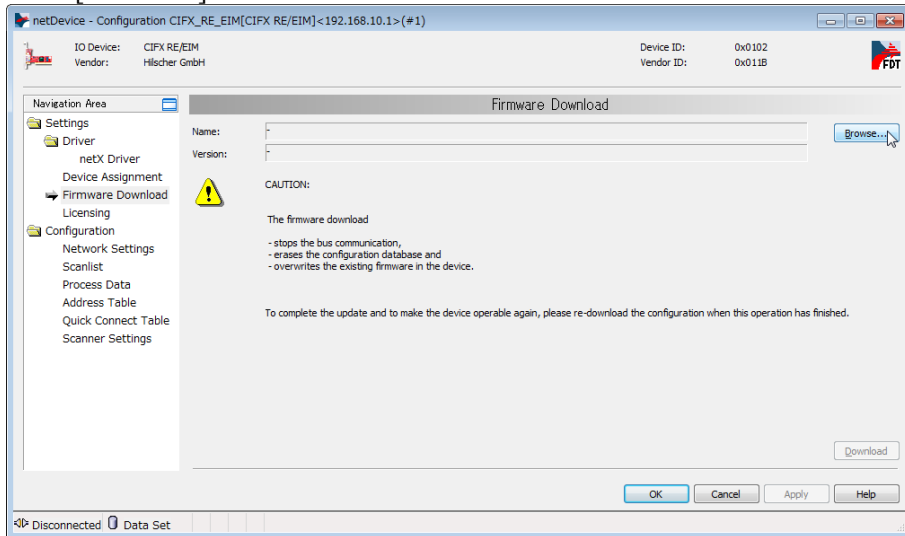

23. Display [Firmware_ EDS_ Examples_ Webpages\Firmware_ & EDS\COMSOL-EIM V2.11.0.3\Firmware\cifX] folder of Communication-Solutions DVD.
Select [cifxeim.nxf].
Click [Open].

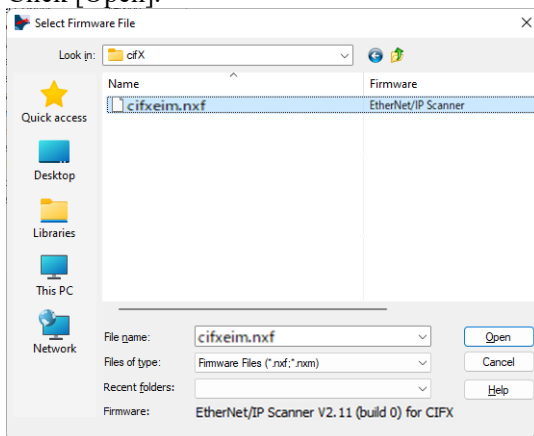

24. Confirm that [Name] is “EtherNet/IP Scanner for CIFX”.
Click [Download].

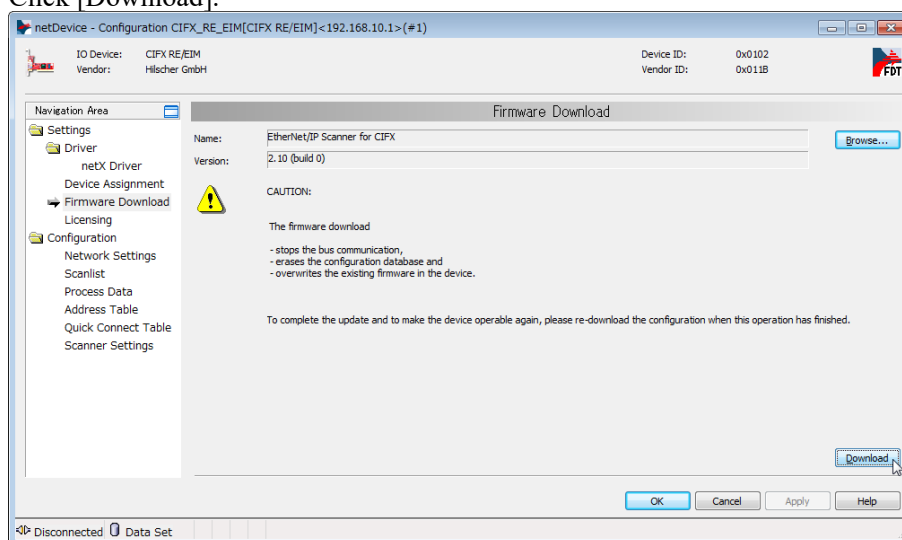

25. Click [Yes].

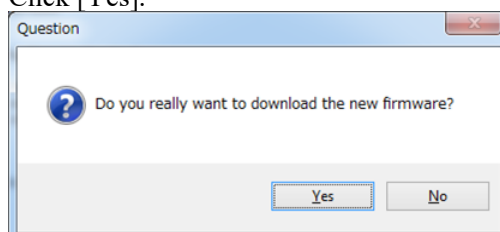

Start the installation of firmware.

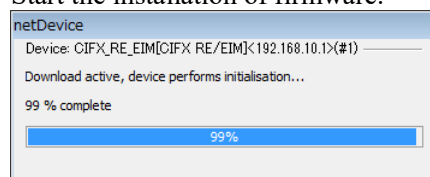

26. Select [Settings]-[Licensing] tab.

27. Confirm that the license of [EtherNet/IP Scanner] is set to “Existing: YES”.

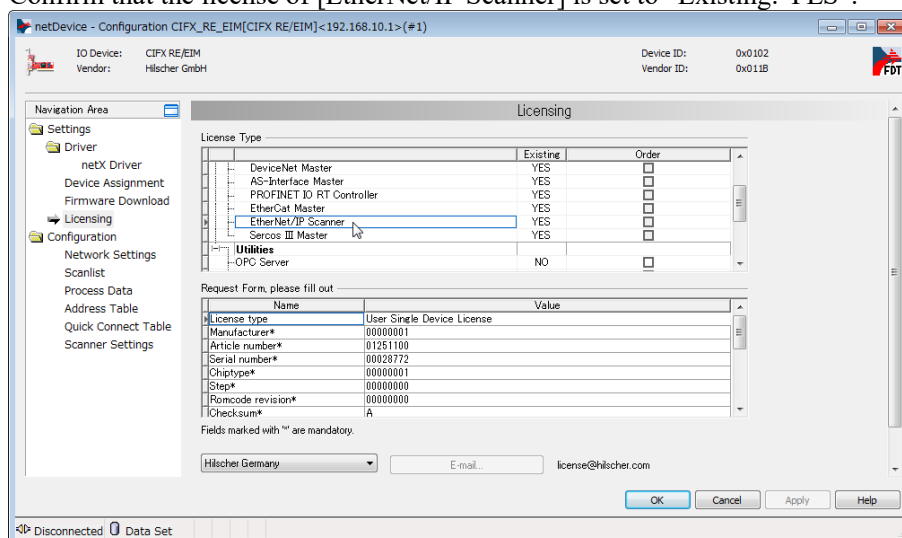

28. Select [Configuration]-[Network Settings] tab.

29. Configure [IP Settings] and click [Apply].
(Ex.) IP Address: 192.168.0.2 (Fixed Addresses)

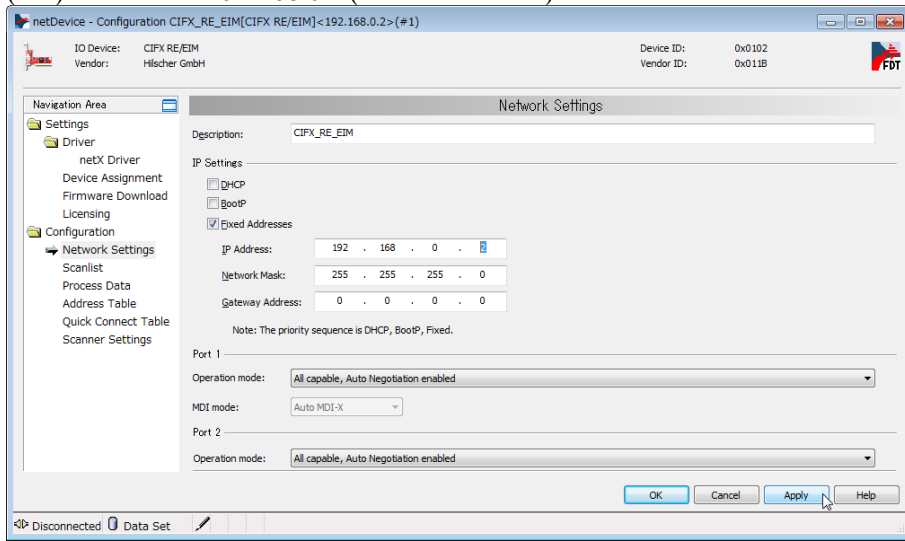

30. Select [Configuration]-[Scanlist].
Select the [Activate] check box of the slave device.

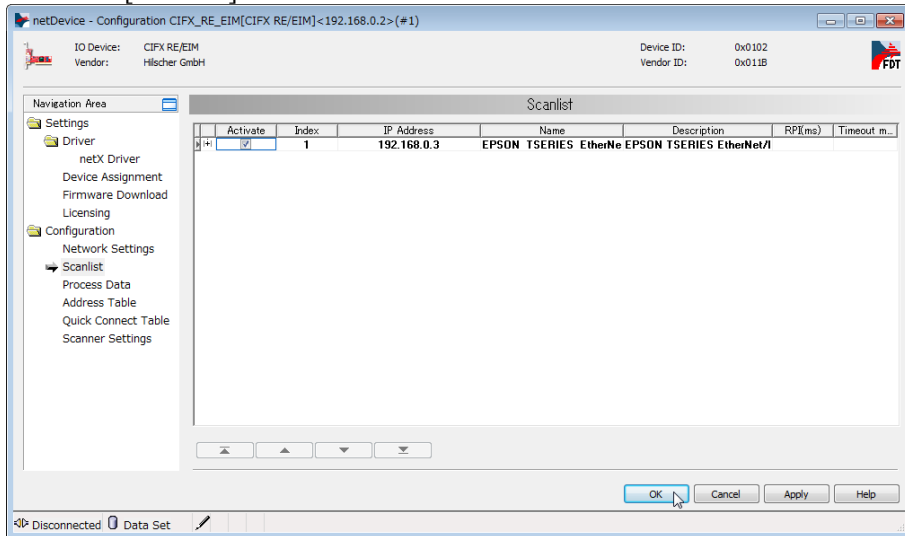

31. Configure [IP Settings] and click [OK].
(Ex.) IP Address: 192.168.0.2 (Fixed Address)
32. Close the [Configuration] dialog box.

Setting on slave side

33. Right-click [netDevice]-[EPSON_TSERIES_EtherNet_IP....] icon.
Select [Configuration...].

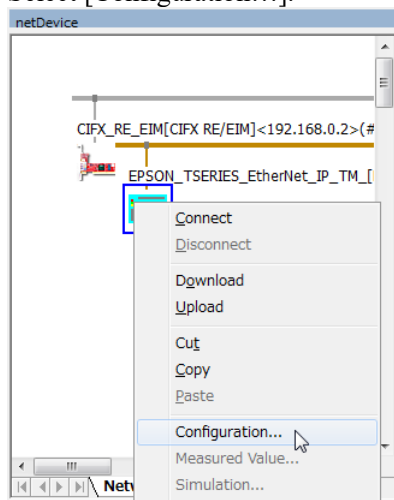

34. The [Configuration] dialog box appears.
35. Select [Configuration]-[Connection].
36. Select [Connection parameters] tab-[Connection1]-[O -> T]-[Size].
Enter "32" to [Parameter] and click [Apply].

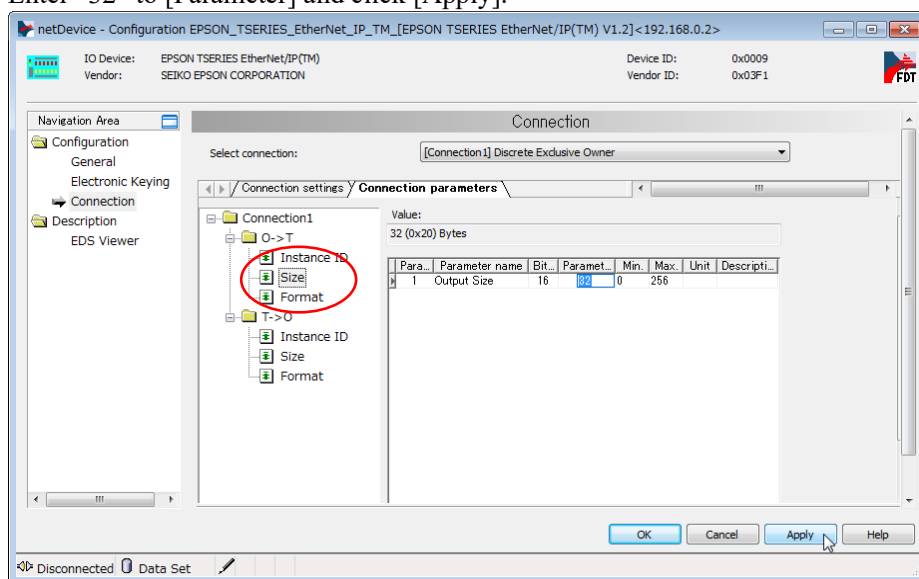

37. Select [Configuration]-[Connection].
38. Select [Connection parameters] tab-[T->O]-[Size].
Enter “32” to [Parameter] and click [OK].

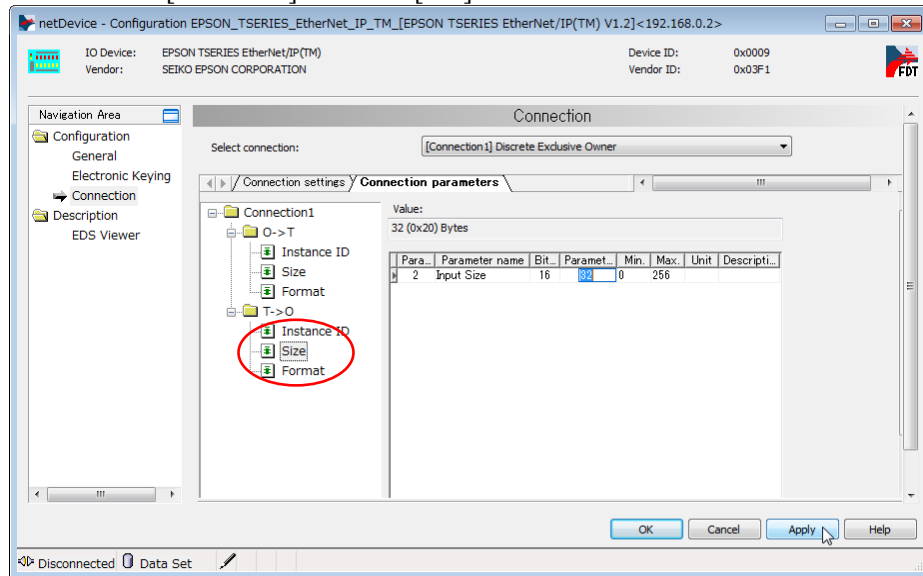

39. Close the [Configuration] dialog box.

Downloading to master board

40. Right-click [netDevice]-[CIFX_RE_EIM] icon again, and click [Configuration...].
The [Configuration] dialog box appears.
41. Click [Configuration]-[Address Table].
42. Check the settings of [Address Table] and click [OK].

“Address Table”-Inputs Length: 0x0020

“Address Table”-Outputs Length: 0x0020

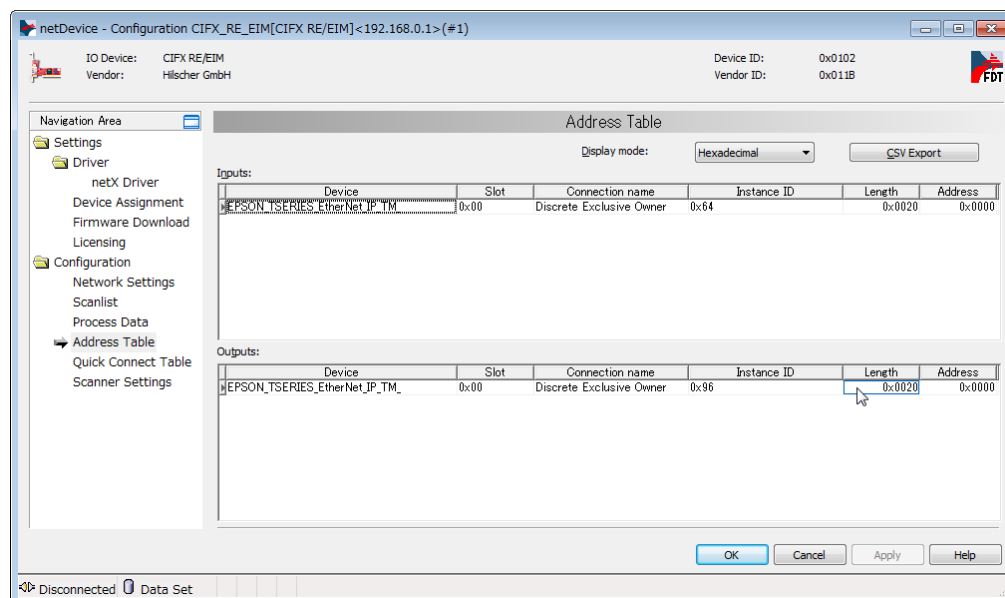

43. Close the [Configuration] dialog box.
44. Right-click [netDevice]-[CIFX_RE_EIM] icon and click [Download].
By the above step, “Setting on master side” and “Setting on slave side” are downloaded to the EtherNet/IP board.

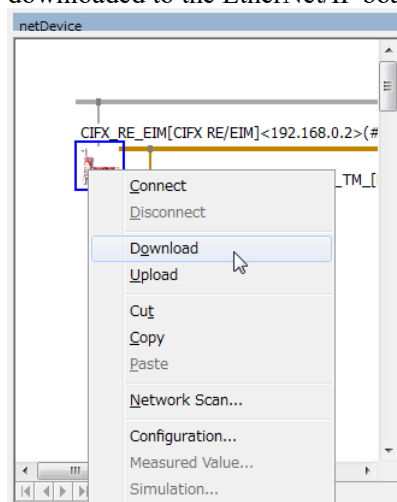

The settings are applied to EtherNet/IP board manufactured by Hilscher.

Diagnosis

- 45. Right-click [netDevice]-[CIFX_RE_EIM] icon.
Select [Diagnosis...].

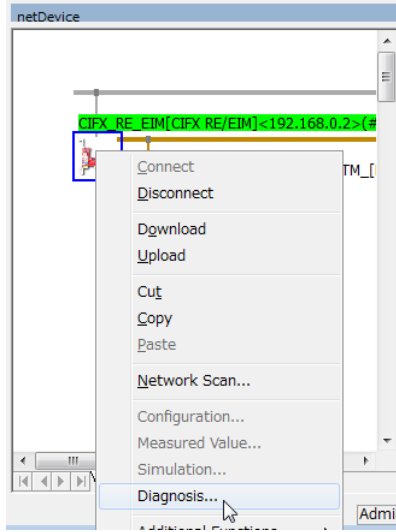

- 46. The [Diagnosis] dialog box appears.
Select [Diagnosis]-[Master Diagnosis].
Right after this, click [Diagnosis]-[General Diagnosis].

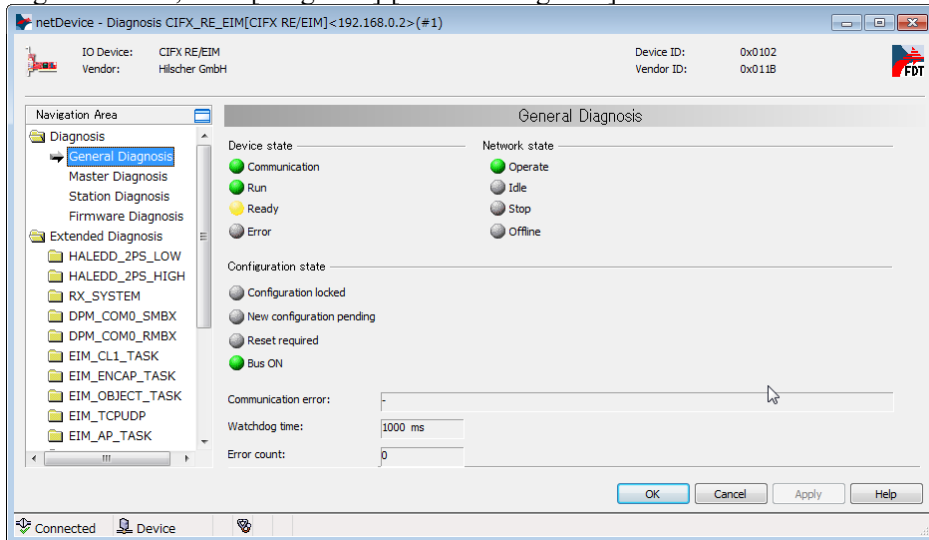

- 47. State is normal when the indicators of Communication, Run, and Bus ON are turned to green and the indicator of Ready is turned ON.

48. Select [Tools]-[IO Monitor] and perform the input/output test.
Click [OK].

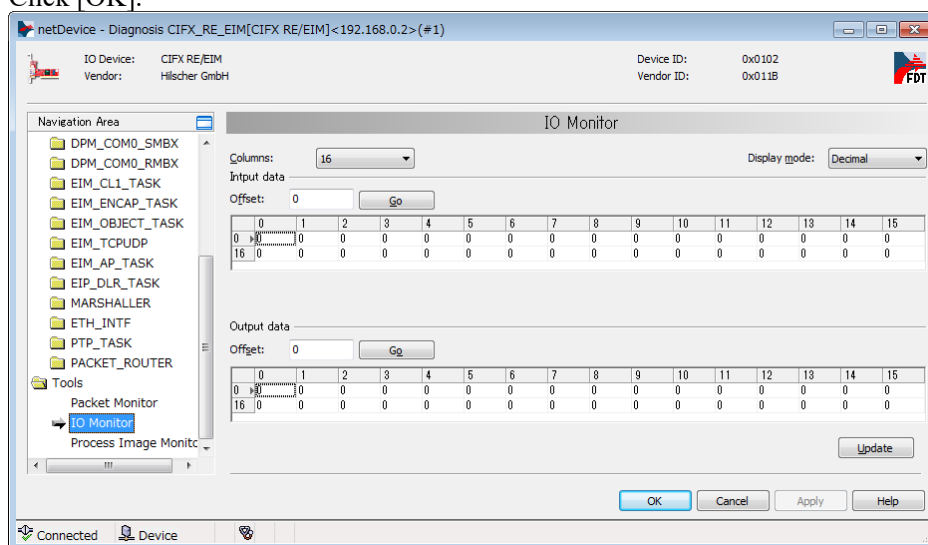

49. Close the [Diagnosis] dialog box.
50. Click [File]-[Save] and save the setting changes to the file.

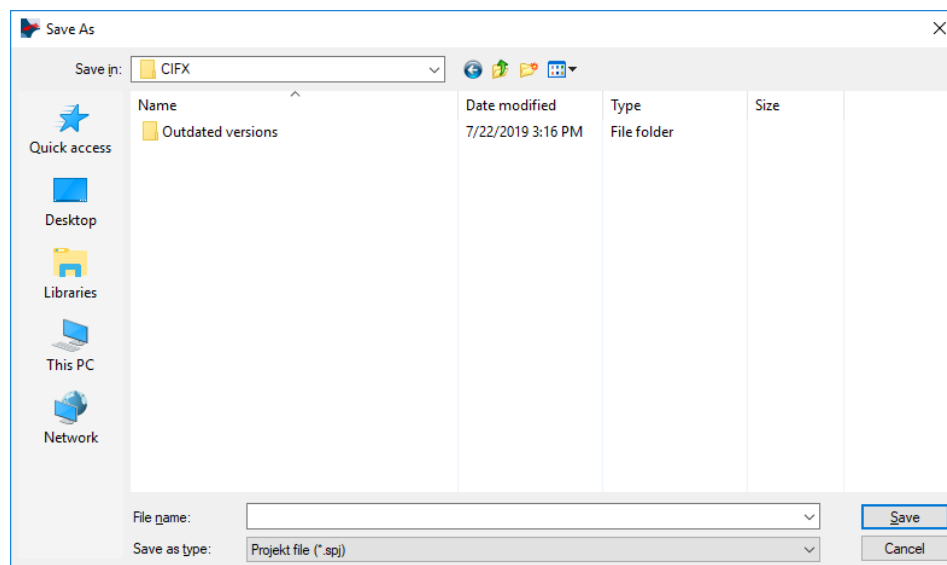
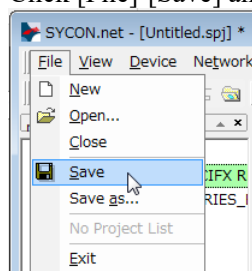

Exporting the Configuration File (.csv) for RC+

51. Right-click [netDevice]-[CIFX_RE_EIM] icon.
Click [Additional Functions]-[Export]-[CSV...].

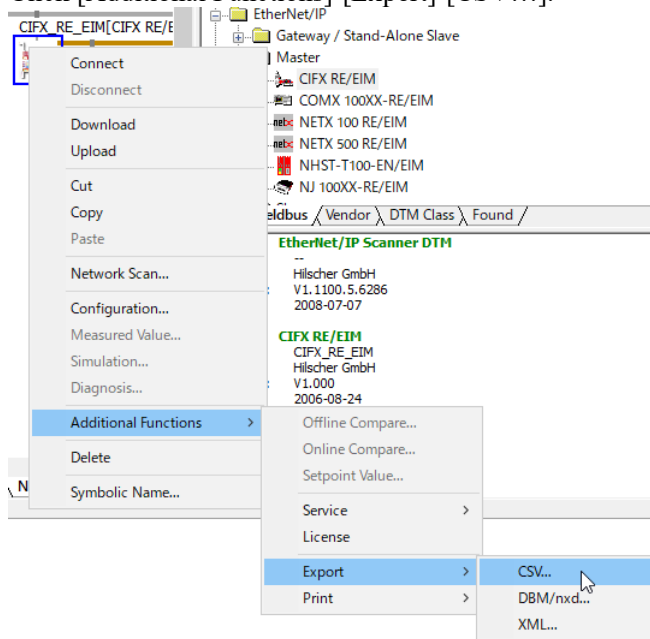

52. Save the CSV file to the file.
Exported CSV file is used in the next *Epson RC+ 8.0 Configuration*.

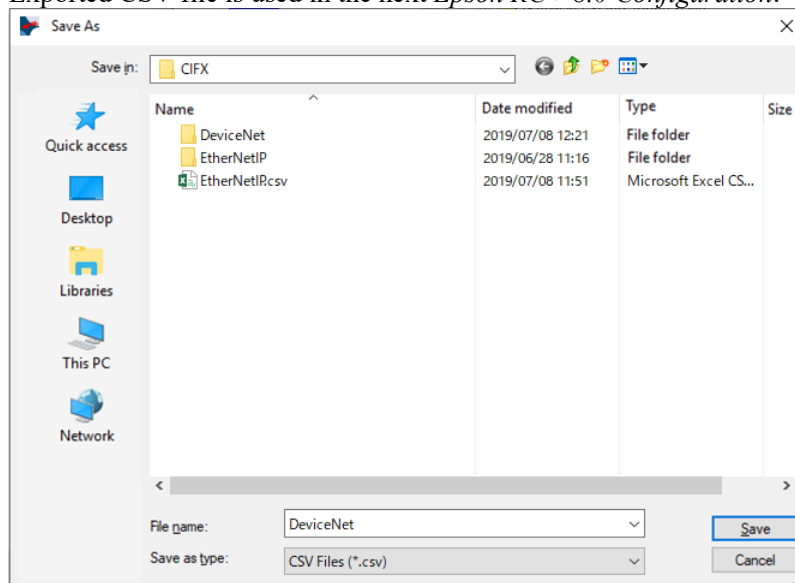

Now, the settings by SYCON.net are complete.
Close SYCON.net.



If there is a problem such as the fieldbus master board is not recognized by Windows, make sure that the combination is described in "Control System Configuration" in the preface of this manual and refer to the following section.

4. Troubleshooting

4.4 How to Disable Fast Startup in Windows

Epson RC+ 8.0 Configuration

To use the Fieldbus master board, the Robot system option setting and Fieldbus master setting should be enabled on Epson RC+ 8.0.

1. Select [Setup]-[License Configuration] and display the [License Configuration] dialog box.
2. Refer to the *Epson RC+ User's Guide: Installing Controller Licenses* and enable the Fieldbus Master option.
3. When the following message displays, click the [OK] button.

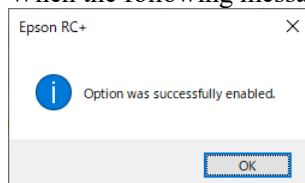

4. Select [Setup]-[System Configuration] and display the [System Configuration] dialog box.
5. Select [Controller]-[Inputs/Outputs]-[Fieldbus Master]-[General].

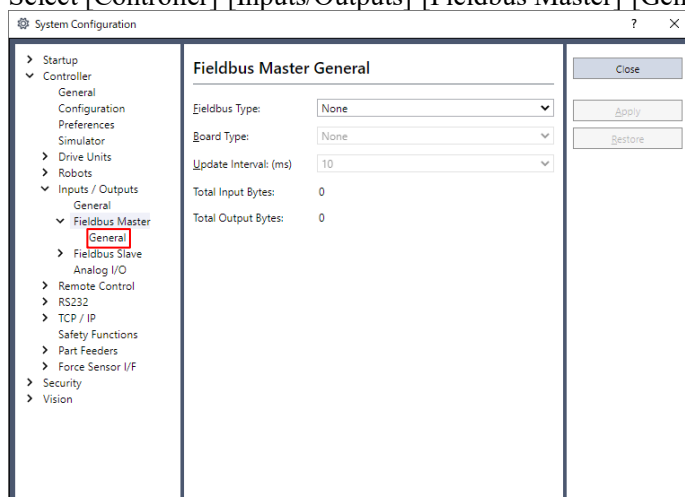

6. Set the following items:
 [Fieldbus Type:] EtherNet/IP
 [Board Type:] Hilscher
 [Update Interval:] Update cycle for the EtherNet/IP master I/O

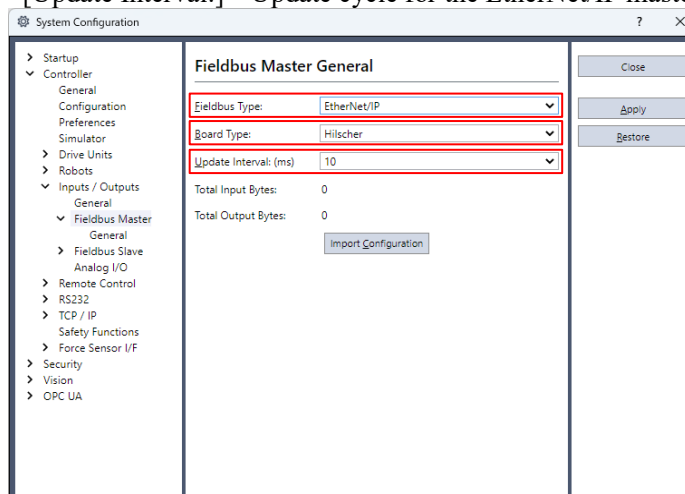

Click [Import Configuration].

7. Select the configuration file (.csv) for RC+. Click [Open].

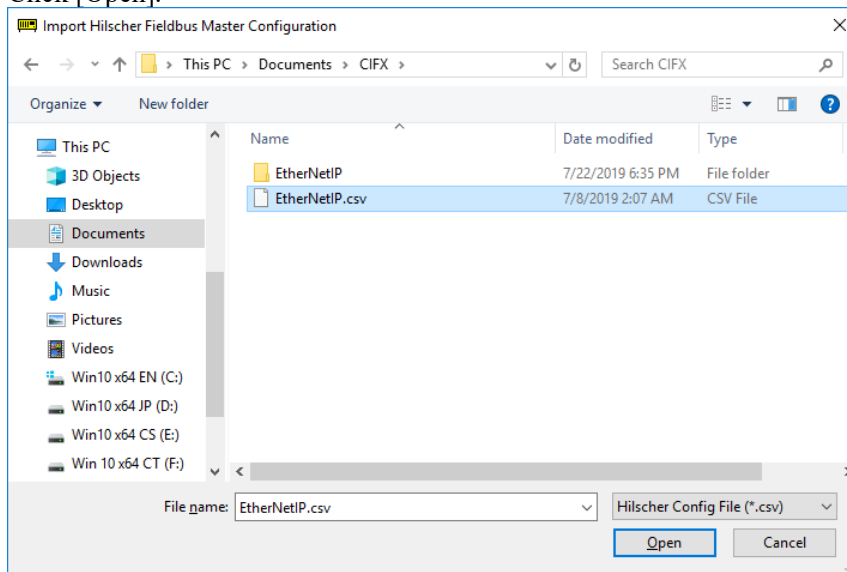

8. Confirm that the configuration file (.csv) for RC+ is imported and click [OK]

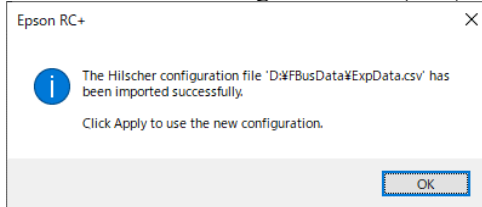

9. Click [Apply]. Confirm that the following items are displayed.

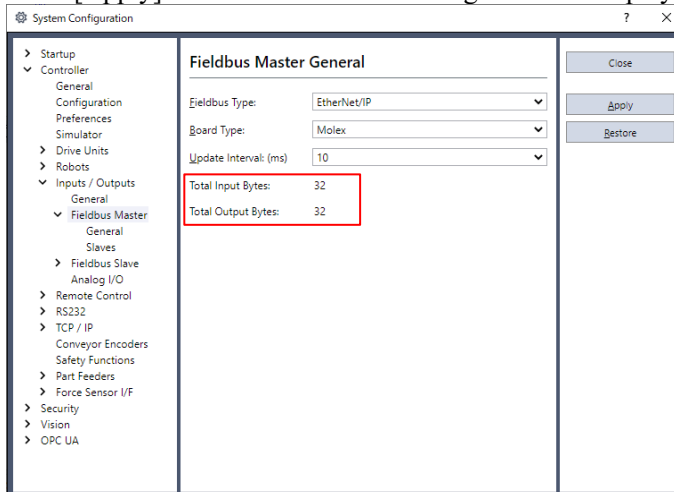

Total Input Bytes : Number of inputs the master controls (Bytes)

Total Output Bytes : Number of outputs the master controls (Bytes)

10. Click [Close]. The following dialog box appears and the Controller automatically starts rebooting.



11. Select [Setup]-[System Configuration] and display the [System Configuration] dialog box.
12. Select [Controller]-[Inputs/Outputs].

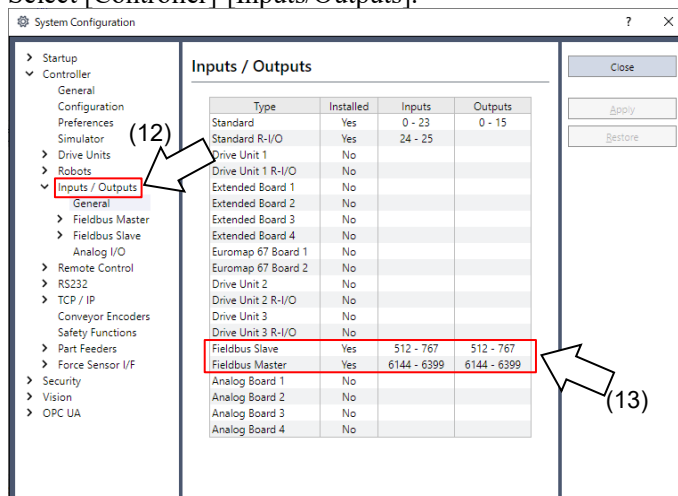

13. Confirm that “Fieldbus Master” displays the following items:

Installed : Yes

Inputs : “6144” – “6144 + Number of inputs the master controls (Bits)”

Outputs : “6144” – “6144 + Number of outputs the master controls (Bits)”

14. Select [Fieldbus Master]-[General].

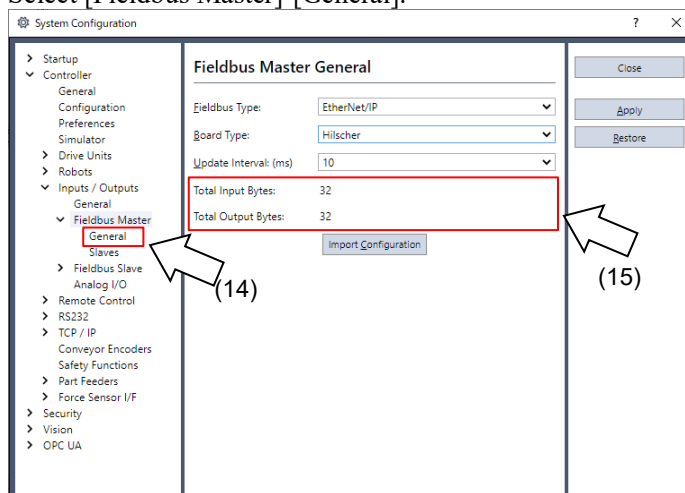

15. Confirm that the following items are displayed.

Total Input Bytes : Number of inputs the master controls (Bytes)

Total Output Bytes : Number of outputs the master controls (Bytes)

16. Select [Fieldbus Master]-[Slaves].

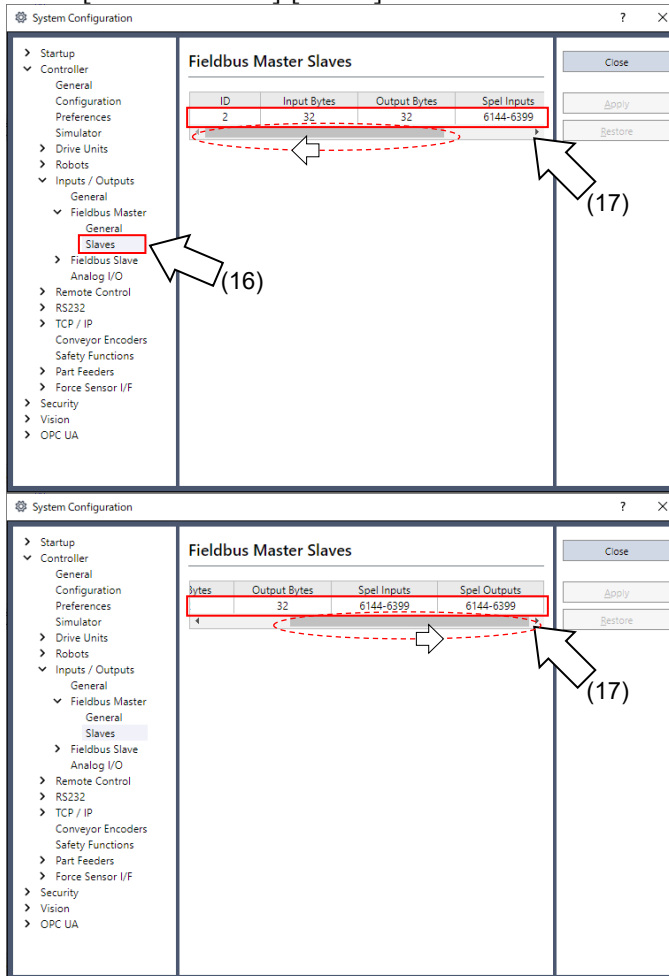

17. Confirm that the following information the master controls is displayed.

- ID : Fieldbus station ID of slave
- Input Bytes : Number of inputs per slave (Bytes)
- Output Bytes : Number of outputs per slave (Bytes)
- Spel Inputs : Number of inputs per slave (Bits)
- Spel Outputs : Number of outputs per slave (Bits)

2.3.5 Installing EtherNet/IP Slave Board

Appearance

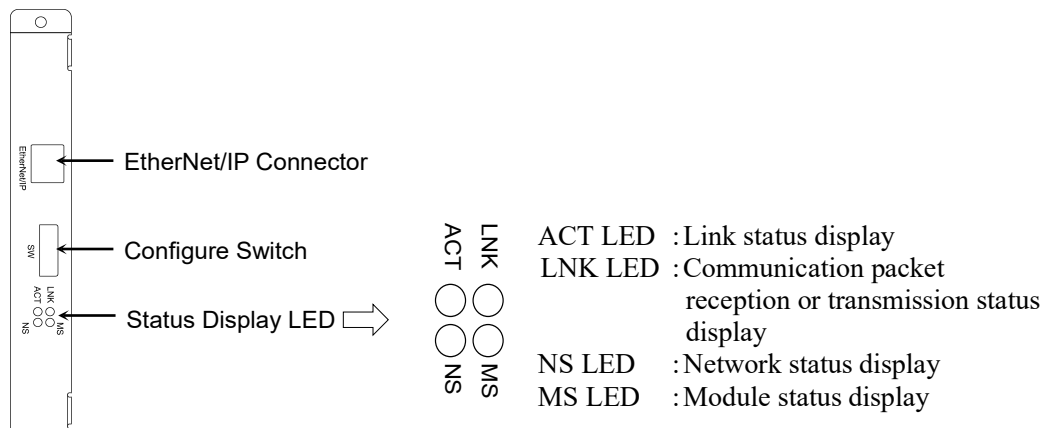

The Fieldbus slave board is configured as follows at shipment.

Board Appearance

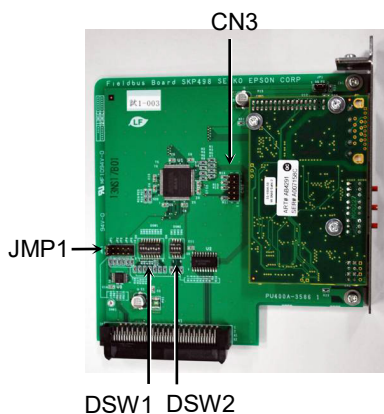

Configuration

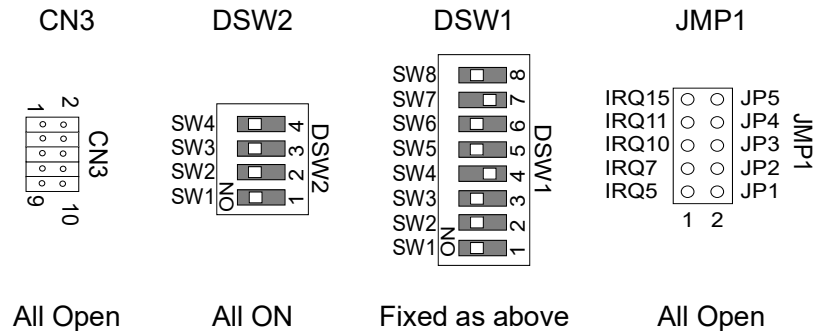

Specifications

Item	Specification
Name	EtherNet/IP slave board
Supported Connection	I/O messaging connection (Cyclic), Explicit messaging connection EtherNet/IP communication protocol
Baud Rates	10 M, 100 M (bps)
Transfer Distance	Standard Ethernet protocol
Cable	Standard Ethernet protocol
Mode	Slave
Interface	1 EtherNet/IP port
Max. Input data size	2048 bits (256 bytes)
Max. Output data size	2048 bits (256 bytes)
Assembly Instance	Input: 100 (64h) size: Depending on I/O settings Output: 150 (96h) size: Depending on I/O settings Configuration: 1 size: 0

LED Description

LED state	MS	NS
OFF	Power supply OFF	Power supply OFF or IP address not configured
GRN	ON	Master connected (executing)
	Blinking	Master connected (idling)
RED	ON	Non-recoverable error
	Blinking	Recoverable error
GRN/RED alternate	Self-diagnosing	Self-diagnosing

LED state	LNK	ACT
OFF	No link	No communication packet reception or transmission
ON	Linking	Communication packet reception or transmission

Setting Configure Switch

 WARNING	<ul style="list-style-type: none"> ■ Make sure that the power is turned OFF before installing/removing any boards or connecting/disconnecting any cables. Working with the power ON is extremely hazardous and may result in electrical shock and/or malfunction of equipment.
---	---

Set all EtherNet/IP board configure switches OFF. Otherwise, the initialization error occurs.

All the EtherNet/IP communication configurations are set by the development software (Epson RC+ 8.0).

Wiring

Use a standard Ethernet connector for wiring to the board.

 CAUTION	<ul style="list-style-type: none"> ■ You can use the general Ethernet hub or Ethernet switch for the EtherNet/IP. However, be sure to use a product complying with the industrial standards or noise resistant Ethernet cable (STP cable). If you use an office use product or UTP cable, it may cause communication errors and may not offer the proper performance.
---	--

Installing a Board

 WARNING	<ul style="list-style-type: none"> ■ Make sure that the power is turned OFF before installing/removing any boards or connecting/disconnecting any cables. Working with the power ON is extremely hazardous and may result in electric shock and/or malfunction of equipment.
---	---

Install the board to the dedicated slot on the Robot Controller.

Reference manuals:

RC700 Series Maintenance MANUAL 7.1 Option Board

RC90 Series Maintenance MANUAL 7.1 Option Board

When using RC700-D and RC700-E, please contact the supplier of your region.

Confirmation and Configuration of Epson RC+ 8.0

When the EtherNet/IP slave board is installed to the Controller, it is recognized automatically. Confirm whether Epson RC+ 8.0 has recognized the EtherNet/IP slave board using the following procedure.

1. Select [Setup]-[System Configuration] and display the [System Configuration] dialog box.
2. Select [Controller]-[Inputs / Outputs].

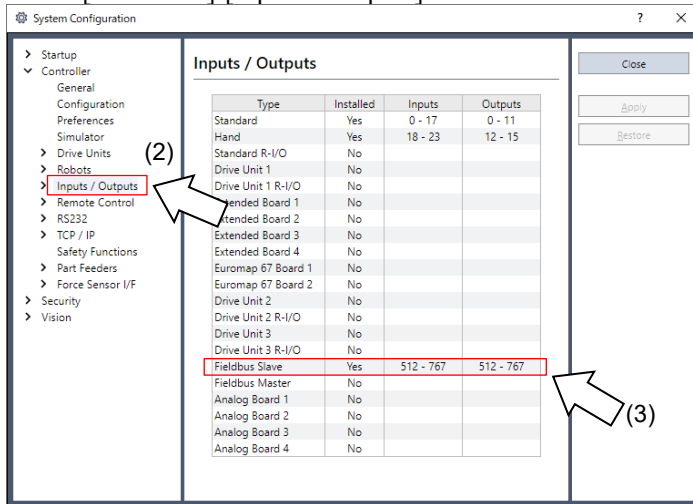

3. Confirm that the following items are displayed in “Fieldbus Slave”.
 - Installed : Yes
 - Inputs : 512-767 (default setting)
 - Outputs : 512-767 (default setting)
4. Select [Fieldbus Slave]-[General].

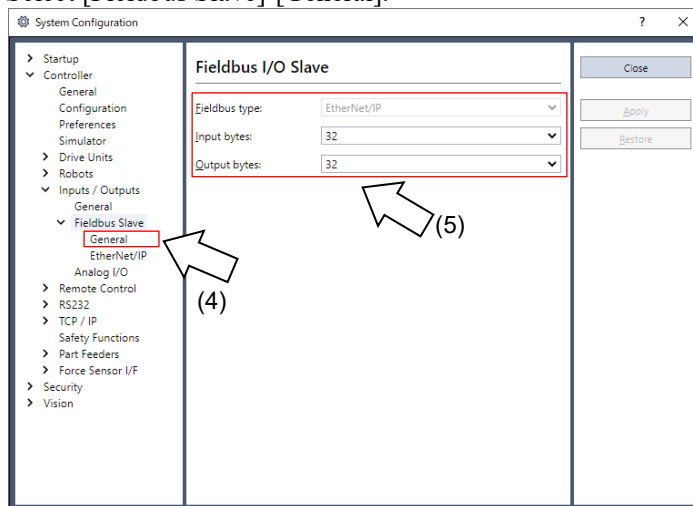

5. Confirm that the following items are displayed.
 - Fieldbus Type : EtherNet/IP
 - Input Bytes : 32 (default setting)
 - Output Bytes : 32 (default setting)
6. Click [Close].

7. Select [Fieldbus Slave]-[EtherNet/IP].

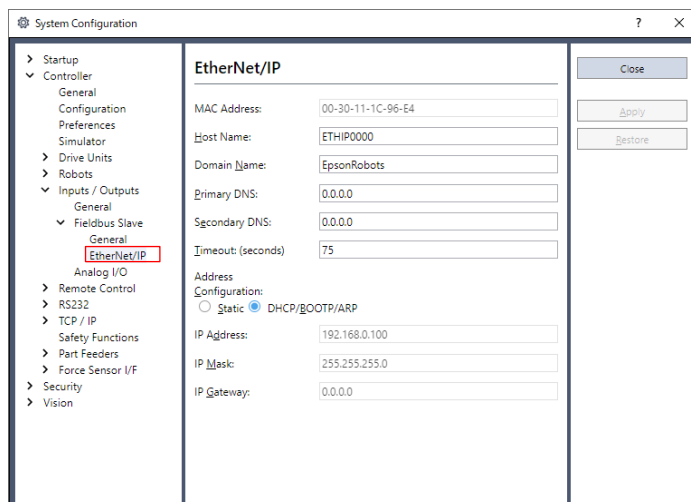

8. Set each item to the specific value to connect the Ethernet network. For information about the setting values, contact your network administrator. Address Configuration is set to “DHCP/BOOTP/ARP” at shipment.
9. When the configuration is completed, click [Apply] to apply the setting.
10. Click [Close].



When Address Configuration is set to “DHCP/BOOTP/ARP”, the Controller waits for DHCP/BOOTP/ARP server response for 30 seconds at Controller startup. When DHCP/BOOTP/ARP does not respond within the time, the Controller stops the request to the DHCP/BOOTP/ARP server and waits ARP.

Editing of Input / Output Size

You can change the input/output size of the EtherNet/IP slave board if necessary.

1. Select [Setup]-[System Configuration] and display the [System Configuration] dialog box.
2. Select [Controller]-[Inputs / Outputs]-[Fieldbus Slave]-[General].

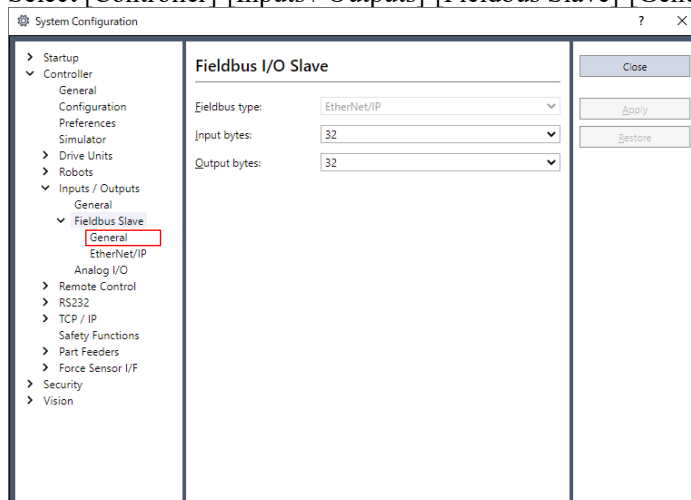

- Change the settings of [Input Bytes] and [Output Bytes].
In this example, both of them are changed to 20 Bytes.

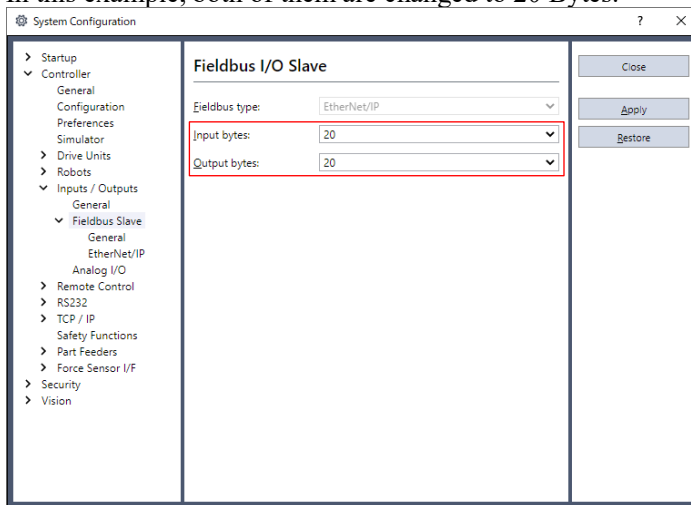

- Click [Apply].
 - Click [Close].
- The following dialog box appears and the Controller automatically starts rebooting.



- Select [Setup]-[System Configuration] and display the [System Configuration] dialog box.
- Select [Controller]-[Inputs / Outputs].

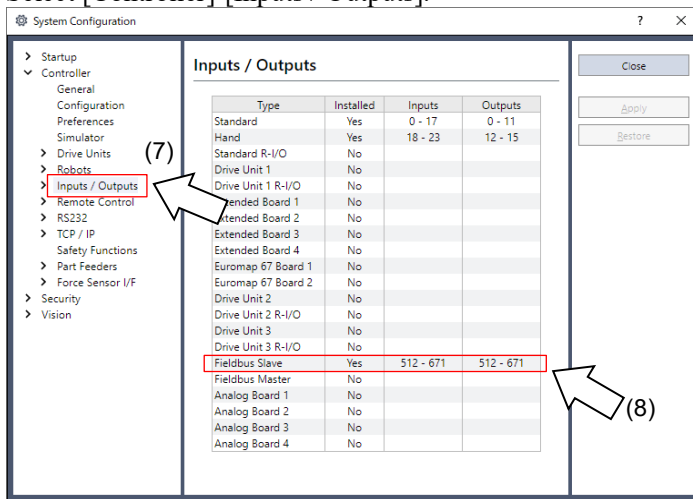

- Confirm that the following items are displayed in “Fieldbus Slave”.
Inputs : 512 – (512 + Changed number of input (Bits))
Outputs : 512 – (512 + Changed number of output (Bits))

In this example, Input byte is 20 bytes (160 bits) and 512-671 is displayed in Inputs. Also, Output byte is 20 bytes (160 bits) and 512-671 is displayed in Outputs.

9. Click [Close].



When you change the input/output size of EtherNet/IP slave board, you need to change the input/output size of the slave information registered in the Fieldbus master device.

Use the window below to change the input/output size of the slave information registered in the Fieldbus master device by the applicomIO Console application.

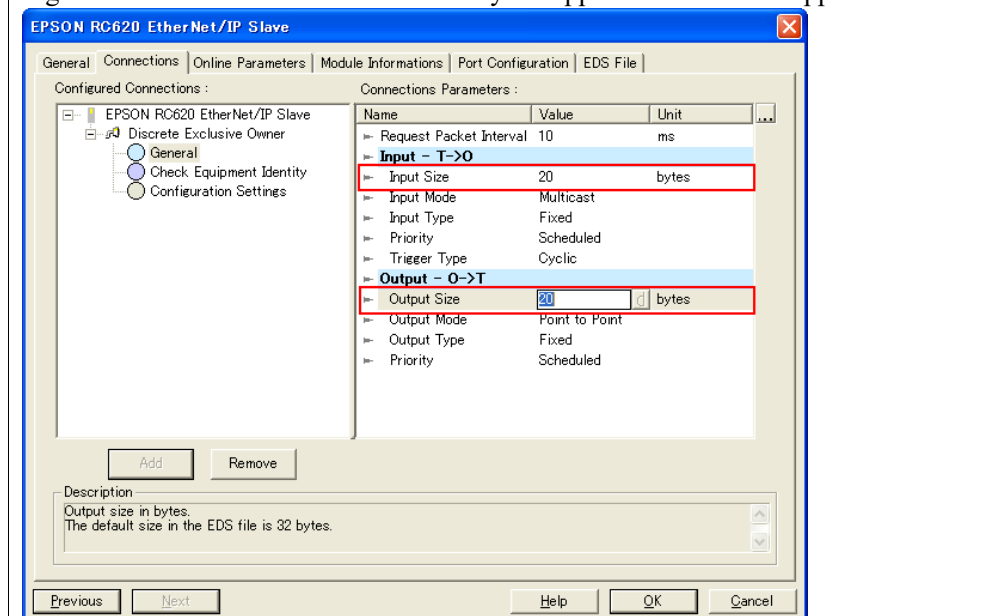

Electronic Information File (EDS file)

An EDS file is supplied for EtherNet/IP slave Board network configuration. The file is located in the following folder where Epson RC+ 8.0 is installed.

C:\EpsonRC80\Fieldbus\EtherNet/IP

Compatible list of EDS file

Fieldbus	Controller	File name
Ethernet/IP	RC700 series	EPSN0800.eds
	RC90 series	EPSN0601.eds
Ethernet/IP for Rockwell	RC700 series	EPSN0800_Rockwell.eds
	RC90 series	EPSN0601_Rockwell.eds

2.3.6 Installing EtherNet/IP Slave Module

 WARNING	<ul style="list-style-type: none"> Make sure that the power is turned OFF before installing/removing any modules or connecting/disconnecting any cables. Working with the power ON is extremely hazardous and may result in electrical shock and/or malfunction of equipment.
--	--

 CAUTION	<ul style="list-style-type: none"> Pay attention to the followings in order to prevent the the connecter from coming off. <ol style="list-style-type: none"> Use the connectors attached to the module. Insert the connectors all the way seated. Fix the cables at proper positions in order not to put a load on the connectors.
--	---

 CAUTION	<ul style="list-style-type: none"> Use the Controller firmware and the EtherNet/IP module in the following combinations. It does not guarantee the correct motions if you use any combination other than those listed below. <table border="1" style="width: 100%; border-collapse: collapse;"> <thead> <tr> <th>Controller</th> <th>Controller Firmware Version</th> <th>Ethernet/IP Module Version</th> </tr> </thead> <tbody> <tr> <td rowspan="3" style="text-align: center;">T/VT Series</td> <td style="text-align: center;">Before 7.5.54.14</td> <td style="text-align: center;">V.1.34</td> </tr> <tr> <td rowspan="2" style="text-align: center;">7.5.54.14 or later</td> <td style="text-align: center;">V.1.34</td> </tr> <tr> <td style="text-align: center;">V.1.58</td> </tr> <tr> <td style="text-align: center;">RC800 Series</td> <td style="text-align: center;">In all versions</td> <td style="text-align: center;">V.1.58</td> </tr> </tbody> </table>	Controller	Controller Firmware Version	Ethernet/IP Module Version	T/VT Series	Before 7.5.54.14	V.1.34	7.5.54.14 or later	V.1.34	V.1.58	RC800 Series	In all versions	V.1.58
Controller	Controller Firmware Version	Ethernet/IP Module Version											
T/VT Series	Before 7.5.54.14	V.1.34											
	7.5.54.14 or later	V.1.34											
		V.1.58											
RC800 Series	In all versions	V.1.58											

NOTE  Refer to *Epson RC+ 8.0 User's Guide "[System Configuration] Command (Setup Menu)" [Setup]-[System Configuration]-[Controller]-[Preferences]* to check the firmware version.

NOTE  The module version of EtherNet/IP is indicated on the label on the back of the module.



Appearance

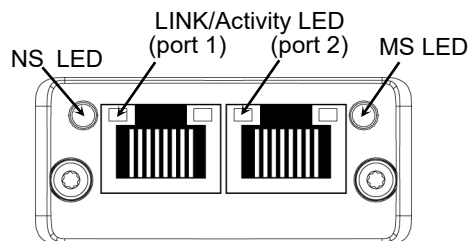

Specifications

Item	Specification	
Name	EtherNet/IP slave module	
Supported Connection	I/O messaging connection (Cyclic), Explicit messaging connection EtherNet/IP communication protocol	
Baud Rates	10 M, 100 M (bps)	
Transfer Distance	Standard Ethernet protocol	
Cable	Standard Ethernet protocol	
Mode	Slave	
Interface	1 EtherNet/IP port	
Max. Input data size	RC800 series	T/VT series
	4096 bits (512 bytes)	2048 bits (256 bytes)
Max. Output data size	RC800 series	T/VT series
	4096 bits (512 bytes)	2048 bits (256 bytes)

LED Description

LED state represents the states of the fieldbus module.

NS: Network Status LED

LED State	Description
Off	No power or no IP address
Green	Online, one or more connections established (CIP Class 1 or 3)
Green, flashing	Online, no connections established
Red	Duplicate IP address, FATAL error
Red, flashing	One or more connections timed out (CIP Class 1 or 3)

MS: Module Status LED

LED State	Description
Off	No power
Green	Controlled by a Scanner in Run state
Green, flashing	Not configured, or Scanner in Idle state
Red	Major fault (EXCEPTION-state, FATAL error etc.)
Red, flashing	Recoverable fault(s). Module is configured, but stored parameters differ from currently used parameters.

LINK/Activity LED

LED State	Description
Off	No link, no activity
Green	Link (100 Mbit/s) established
Green, flickering	Activity (100 Mbit/s)
Yellow	Link (10 Mbit/s) established
Yellow, flickering	Activity (10 Mbit/s)

Setting Configure Switch



WARNING

- Make sure that the power is turned OFF before installing/removing any modules or connecting/disconnecting any cables. Working with the power ON is extremely hazardous and may result in electrical shock and/or malfunction of equipment.

Set all EtherNet/IP modules configure switches OFF. Otherwise, the initialization error occurs.

All the EtherNet/IP communication configurations are set by the development software (Epson RC+ 8.0).

Wiring

Use a standard Ethernet connector for wiring to the module.

 CAUTION	<p>■ You can use the general Ethernet hub or Ethernet switch for the EtherNet/IP. However, be sure to use a product complying with the industrial standards or noise resistant Ethernet cable (STP cable). If you use an office use product or UTP cable, it may cause communication errors and may not offer the proper performance.</p>
--	---

Installing Module

 WARNING	<p>■ Make sure that the power is turned OFF before installing/removing any modules or connecting/disconnecting any cables. Working with the power ON is extremely hazardous and may result in electric shock and/or malfunction of equipment.</p>
--	---

Install the module to the dedicated slot on the Controller.

Reference manuals:

T series MAINTENANCE MANUAL 14.6 Fieldbus I/O

T-B series MAINTENANCE MANUAL 14.5 Fieldbus I/O

VT series MAINTENANCE MANUAL 18.7 Fieldbus I/O

RC800 series Service Manual 4.1.3 Fieldbus I/O Module

Confirmation and Configuration of Epson RC+ 8.0

When the EtherNet/IP slave module is installed to the Controller, it is recognized automatically. Confirm whether Epson RC+ 8.0 has recognized the EtherNet/IP slave module using the following procedure.

1. Select [Setup]-[System Configuration] and display the [System Configuration] dialog box.

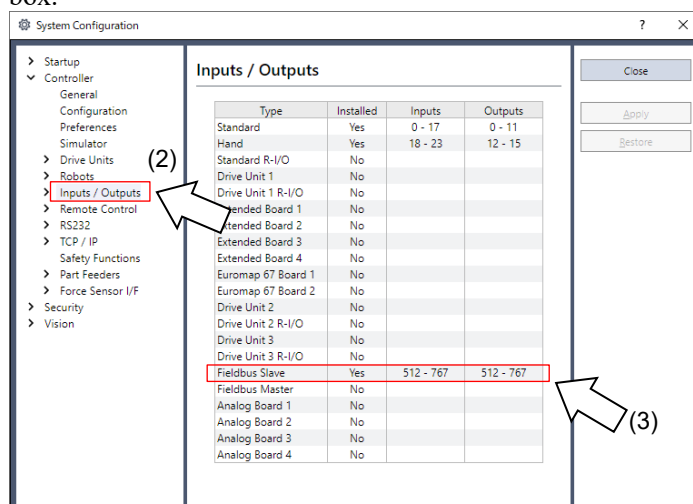

2. Select [Controller]-[Inputs / Outputs].
3. Confirm that the following items are displayed in “Fieldbus Slave”.
 - Installed : Yes
 - Inputs : 512-767 (default setting)
 - Outputs : 512-767 (default setting)

4. Select [Fieldbus Slave]-[General].

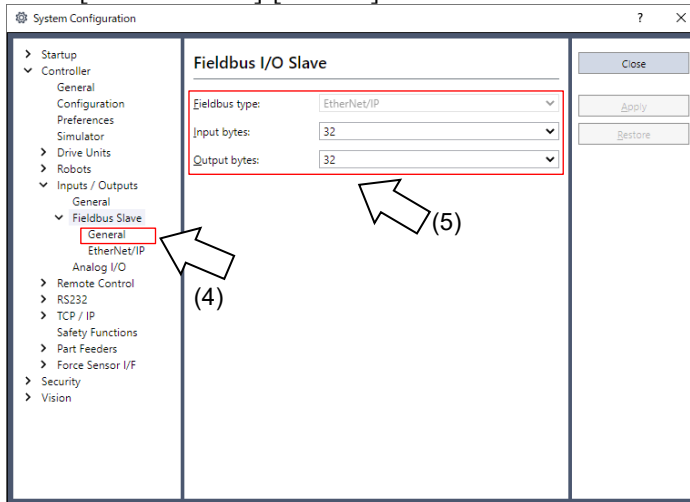

5. Confirm that the following items are displayed.

Fieldbus Type : EtherNet/IP
 Input Bytes : 32 (default setting)
 Output Bytes : 32 (default setting)

6. Click [Close].

7. Select [Fieldbus Slave]-[EtherNet/IP].

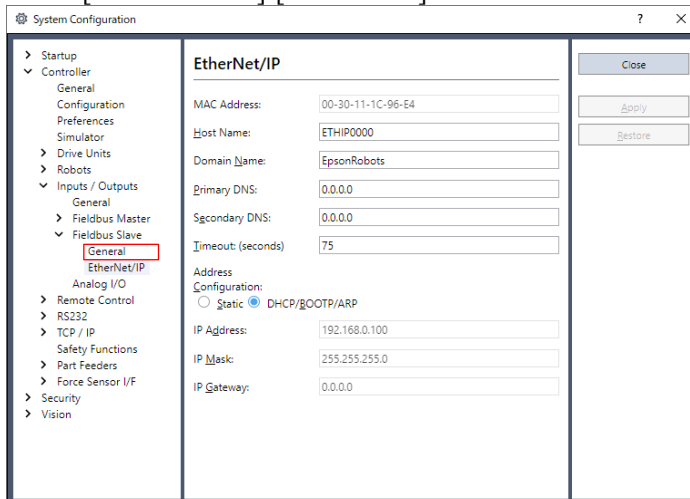

8. Set each item to the specific value to connect the Ethernet network.
 For information about the setting values, contact your network administrator.
 Address Configuration is set to “DHCP/BOOTP/ARP” at shipment.

9. When the configuration is completed, click [Apply] to apply the setting.

10. Click [Close].



When Address Configuration is set to “DHCP/BOOTP/ARP”, the Controller waits for DHCP/BOOTP/ARP server response for 30 seconds at Controller startup. When DHCP/BOOTP/ARP does not respond within the time, the Controller stops the request to the DHCP/BOOTP/ARP server and waits ARP.

Editing of Input / Output Size

You can change the input/output size of the EtherNet/IP slave module if necessary.

1. Select [Setup]-[System Configuration] and display the [System Configuration] dialog box.
2. Select [Controller]-[Inputs / Outputs]-[Fieldbus Slave]-[General].

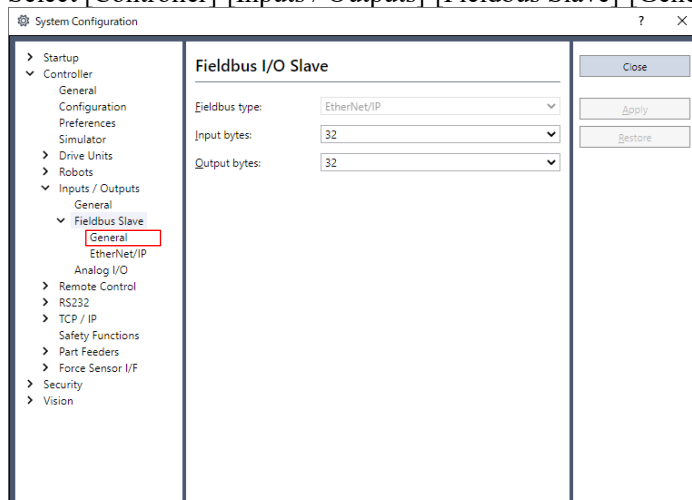

3. Change the settings of [Input Bytes] and [Output Bytes].
In this example, both of them are changed to 20 Bytes.

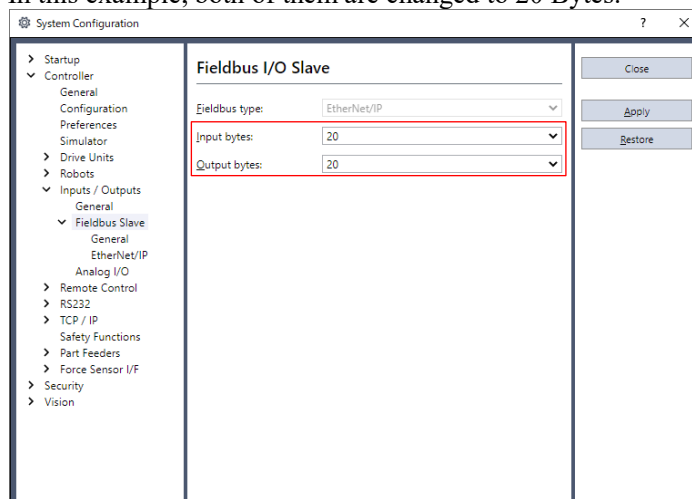

4. Click [Apply].
5. Click [Close].
The following dialog box appears and the Controller automatically starts rebooting.



6. Select [Setup]-[System Configuration] and display the [System Configuration] dialog box.
7. Select [Controller]-[Inputs / Outputs].

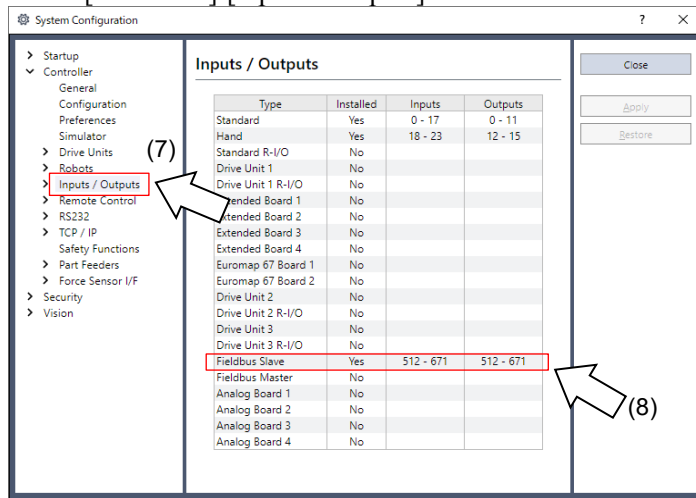

8. Confirm that the following items are displayed in “Fieldbus slave”.
 - Inputs : 512 – (512 + Changed number of input (Bits))
 - Outputs : 512 – (512 + Changed number of output (Bits))

In this example, Input byte is 20 bytes (160 bits) and 512-671 is displayed in Inputs.
 Also, Output byte is 20 bytes (160 bits) and 512-671 is displayed in Outputs.

9. Click [Close].



When you change the input/output size of EtherNet/IP slave module, you need to change the input/output size of the slave information registered in the Fieldbus master device.

Use the window below to change the input/output size of the slave information registered in the Fieldbus master device by the applicomIO Console application.

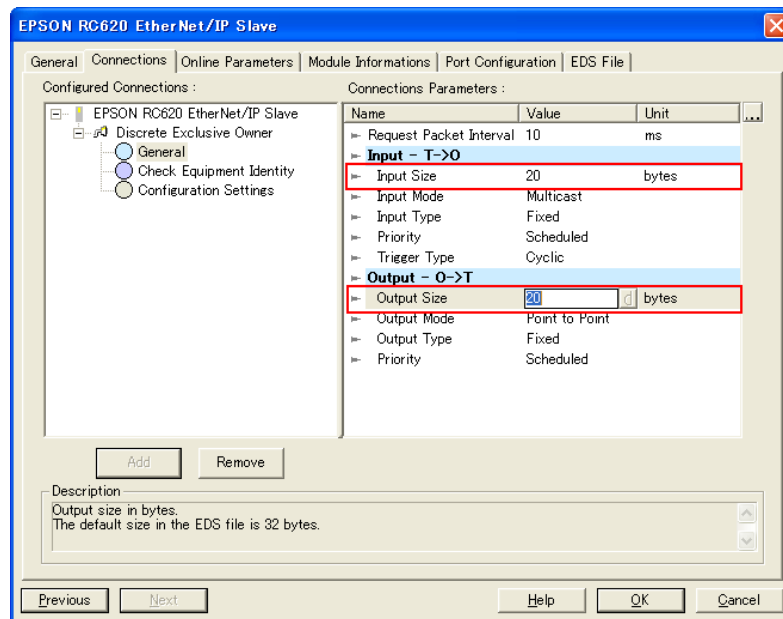

“Encapsulation Inactivity Timeout”

Fieldbus EtherNet/IP slave module supports “Encapsulation Inactivity Timeout” which is added by EtherNet/IP standard update.

If the EtherNet/IP master device is not supported for the standard on the above, connection will be disconnected.

You need to change the “Encapsulation Inactivity Timeout” set value of the slave on the EtherNet/IP master device side.

For more details, refer to 2.3.3 *Installing EtherNet/IP Master Board Manufactured by molex How to Change the Set Value on the Master Side.*

Electronic Information File (EDS file)

An EDS file is supplied for EtherNet/IP slave module network configuration. The file is located in the following folder where Epson RC+ 8.0 is installed.

C:\EpsonRC80\Fieldbus\EtherNetIP

Use in the following combinations.

Compatible list of EDS file

Controller	Controller Firmware Version	EtherNet/IP Module Version	File Name
T/VT Series	Before 7.5.54.14	V.1.34	EPSN0901.eds
			EPSN0901_Rockwell.eds
	7.5.54.14 or later	V.1.34	EPSN0901.eds
			EPSN0901_Rockwell.eds
		V.1.58	EPSN0902.eds
RC800 Series	All versions	V.1.58	EPSN1100.eds

2.4 CC-Link

2.4.1 Installing CC-Link Slave Board

 WARNING	<p>■ Make sure that the power is turned OFF before installing/removing any boards or connecting/disconnecting any cables. Installing/removing any boards or connecting/disconnecting any cables with the power ON is extremely hazardous and may result in electric shock and/or malfunction of equipment.</p>
---	--

 CAUTION	<p>■ Pay attention to the followings in order to prevent the the connector from coming off.</p> <ol style="list-style-type: none"> 4. Use the connectors attached to the board. 5. Insert the connectors all the way seated. 6. Fix the cables at proper positions in order not to put a load on the connectors.
---	---

Appearance

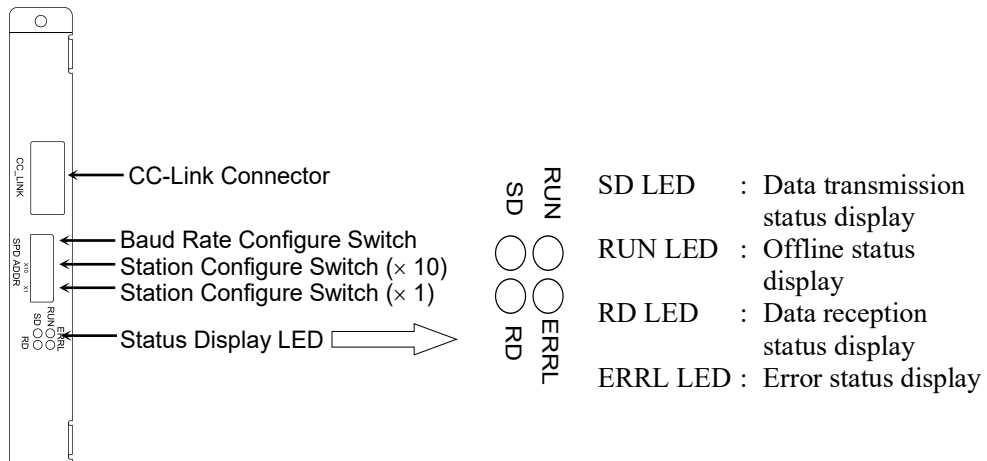

The Fieldbus slave board is configured as follows at shipment.

Board Appearance

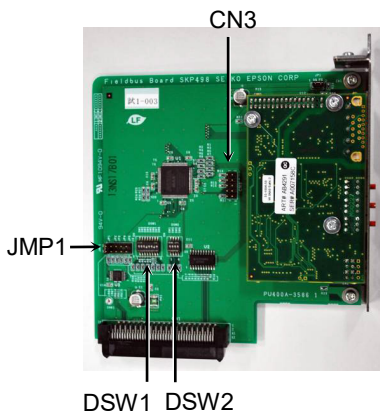

Configuration



Specifications

Item	Specification	
Name	CC-Link Slave Board	
Connection Method	Broadcast polling	
Baud Rates (bps)	156 k, 625 k, 2.5 M, 5 M, 10 M (bps)	
Transfer Distance	Baud Rates	Cable Length
	10 M (bps)	100 m
	5 M (bps)	160 m
	2.5 M (bps)	400 m
	625 k (bps)	900 m
156 k (bps)	1200 m	
Maximum Device Number	64 units	
Cable	Dedicated cable supporting CC-Link Ver.1.10	
Mode	Slave	
Interface	CC-Link Ver1.10 / Ver2.00 1 port	
Occupied Stations	1 to 4 station(s) (Remote device station)	
Master Station's Handshake		
Max. Input Data Size (Ver1.10)	384 bits (48 bytes)	
Max. Input Data Size (Ver2.00)	1472 bits (184 bytes)	
Max. Output Data Size (Ver1.10)	384 bits (48 bytes)	
Max. Output Data Size (Ver2.00)	1472 bits (184 bytes)	

LED Description

LED state represents the states of the fieldbus I/O board.

LED state	ERRL RED	RUN GRN	RD GRN	SD GRN
OFF	Normal operation Device power supply OFF	Offline Device power supply OFF	No data reception Device power supply OFF	No data transmission Device power supply OFF
ON	CRC error: station Address error Baud rate configuration error	Normal operation	Data reception	Data transmission
Blinking	–	–	–	–

Setting Configure Switch



WARNING

- Make sure that the power is turned OFF before installing/removing any boards or connecting/disconnecting any cables. Working with the power ON is extremely hazardous and may result in electrical shock and/or malfunction of equipment.

Configuration of the device station is available with the station configure switch on the CC-Link slave board.

Baud rate configuration is available with baud rate configure switch on the CC-Link board.

1. Set the station of the CC-Link slave board with the station configuration switch. Make sure that the station does not duplicate with the other devices inside the network at configuration.
Switches on the $\times 10$ side are for tenths digit address value configuration. Switches on the $\times 1$ side are for units digit address value configuration. Stations from 1 to 64 are available.
2. Set the CC-Link baud rate. Check the master configuration and set the same baud rate. Refer to the following table for configuration.

Baud Rate	Switch
156 k	0
625 k	1
2.5 M	2
5 M	3
10 M	4
Configuration prohibited	5-9

Wiring

The CC-Link connector is a 5-pin open connector. Use the connector attached to the board for wiring.

Terminal name for each pin

Terminal No	Terminal Name
1	DA
2	DB
3	DG
4	SLD
5	FG

Connect the CC-Link master module and the CC-Link slave board as follows.

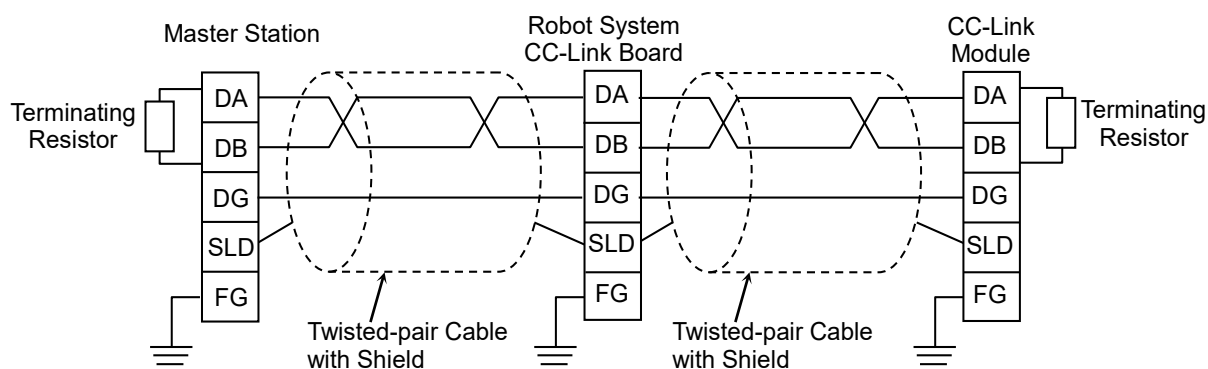

NOTE Prepare the cable for CC-Link Ver.1.10 sold in the market as a communication cable.
 Install terminating resistors at both ends of the network.
 Use the terminating resistors attached to the CC-Link master station.

Make sure to disconnect the connectors only after turning OFF the power supply of the specific station.

Connect the shield wire for CC-Link to the “SLD” of each unit and ground the both ends via “FG”.

Installing a Board



WARNING

- Make sure that the power is turned OFF before installing/removing any boards or connecting/disconnecting any cables. Working with the power ON is extremely hazardous and may result in electrical shock and/or malfunction of equipment.

Install the board to the dedicated slot on the Robot Controller.

Reference manuals:

RC700 Series Maintenance MANUAL 7.1 Option Board

RC90 Series Maintenance MANUAL 7.1 Option Board

When using RC700-D and RC700-E, please contact the supplier of your region.

Compliance with the EMC regulations

Our robot controllers and optional CC-Link boards are built into mechanical devices.

EMC compliance with your end product (entire mechanical device which builds our products into the device) varies depending on configuration, wiring, placement, and so on. Therefore, please judge the EMC compliance of your final product by yourself.

An example of EMC countermeasures is described below.

- Mount a ferrite core to the CC-Link cable to reduce radiation noise.
- Use the exclusive cable for CC-Link.
- Place the ferrite core as close as possible to the controller.
- Change the number of the cable turns to the ferrite core depending on the radiation noise condition.
- Use the ferrite core listed in the table below or equivalent.

Manufacturer	Part number
Kitagawa Industries Co., LTD.	GTFC-41-27-16

Example: Robot Controller RC700 series

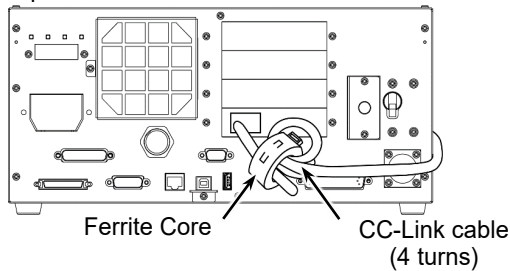

Example: Robot Controller RC90 series

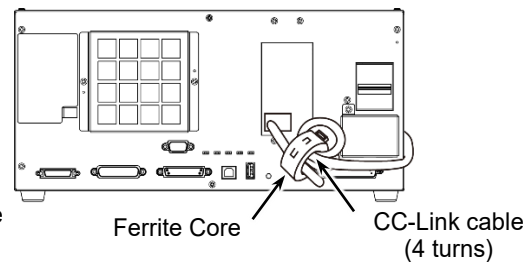

- This example is an idea of the EMC countermeasures in our installation and wiring conditions. The test result may vary in your testing environment.

Confirmation of Epson RC+ 8.0

When the CC-Link slave board is installed to the Controller, it is recognized automatically. Confirm whether Epson RC+ 8.0 has recognized the CC-Link board using the following procedure.

1. Select [Setup]-[System Configuration] and display the [System Configuration] dialog box.
2. Select [Controller]-[Inputs / Outputs].

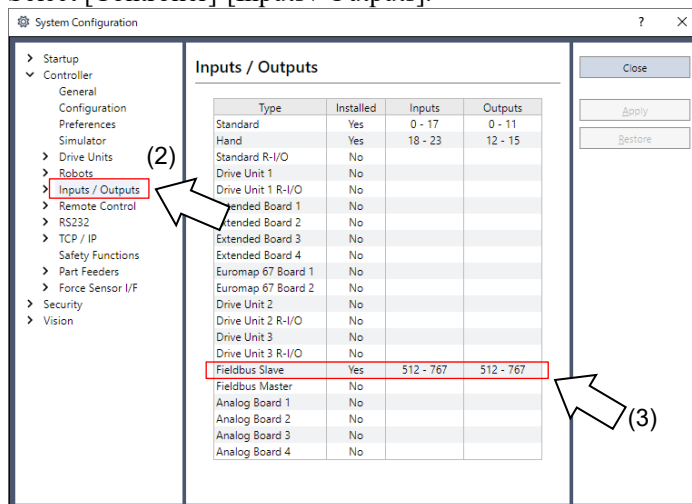

3. Confirm that the following items are displayed in “Fieldbus slave”.

Installed : Yes
 Inputs : 512-767 (default setting)
 Outputs : 512-767 (default setting)

4. Select [Fieldbus Slave]-[General].

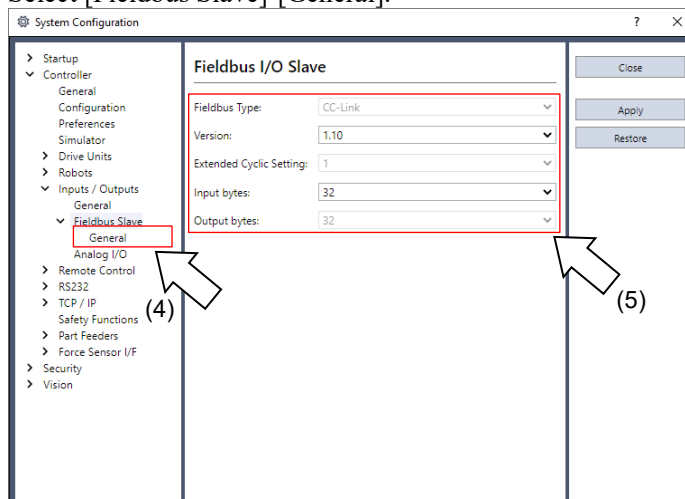

5. Confirm that the following items are displayed.

Fieldbus Type : CC-Link
 Version : 1.10 (default setting)
 Extended Cyclic Setting : (gray out) (default setting)
 Input Bytes : 32 (default setting)
 Output Bytes : 32 (default setting)

6. Click [Close].



These is no Extended Cyclic Setting on CC-Link Ver1.10.
 If you change Version to 2.00, you can configure Extended Cyclic Setting.

Editing of Input / Output Size

You can change the input/output size of the CC-Link slave board if necessary.

1. Select [Setup]-[System Configuration] and display the [System Configuration] dialog box.
2. Select [Controller]-[Inputs / Outputs]-[Fieldbus Slave]-[General].

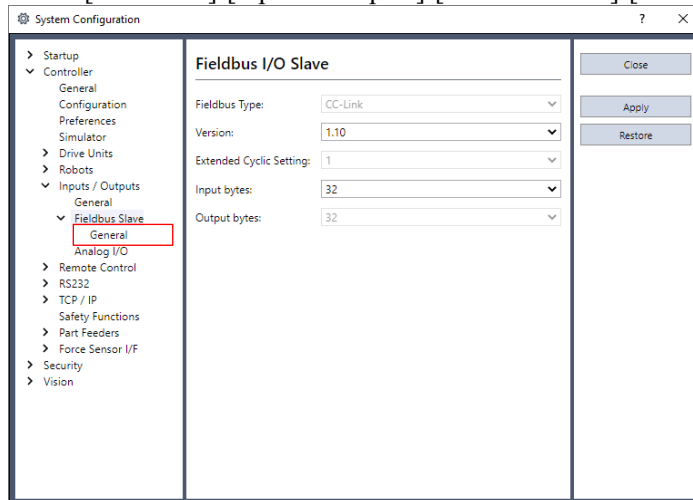

3. Change the settings of [Version] of CC-Link.

In this example, Version is changed to “2.00”.

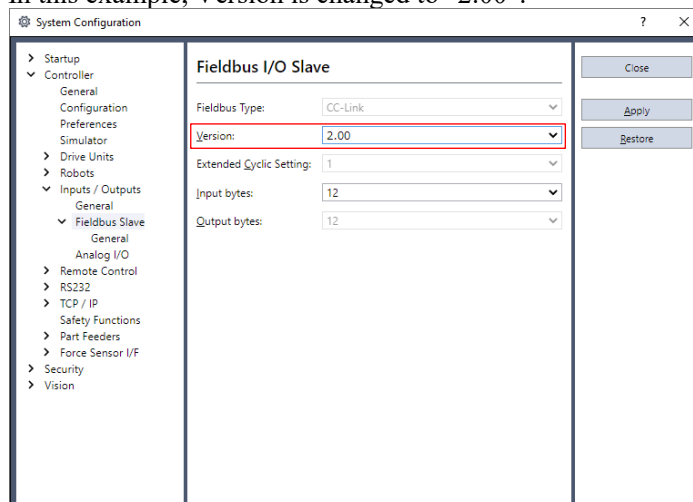

- Change the settings of [Extended Cyclic Setting].

In this example, Extended Cyclic Setting is changed to “2”.

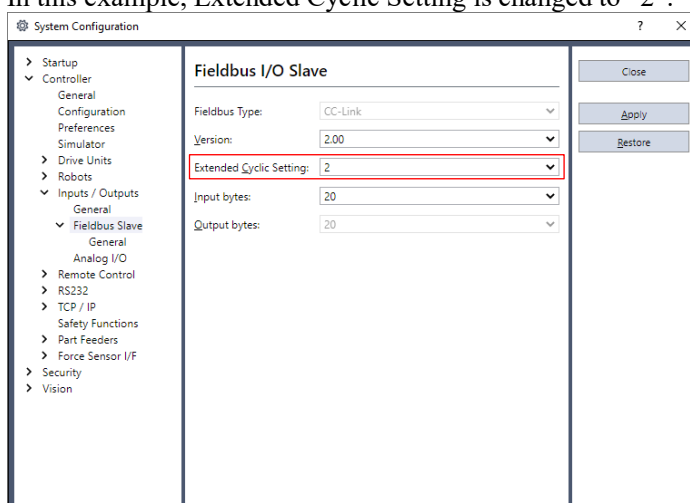

- Change the settings of [Input Bytes] and [Output Bytes].

In this example, both of them are changed to “92” Bytes.

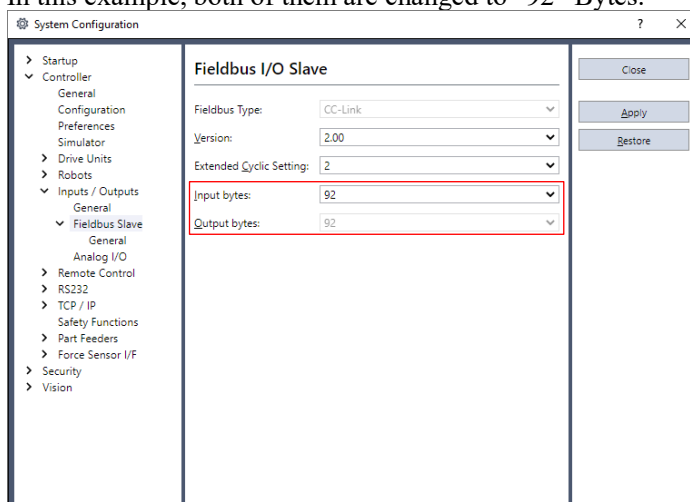

- Click [Apply].

- Click [Close].

The following dialog box appears and the Controller automatically starts rebooting.



- Select [Setup]-[System Configuration] and display the [System Configuration] dialog box.

9. Select [Controller]-[Inputs / Outputs].

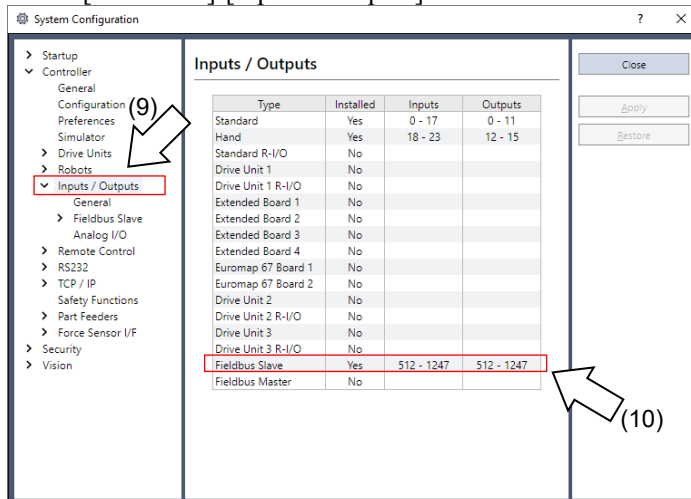

10. Confirm that the following items are displayed in “Fieldbus Slave”.

Inputs : 512 – 1247

Outputs : 512 – 1247

In this example, Input byte is 92 bytes (736 bits) and 512-1247 is displayed in Inputs.

Also, Output byte is 92 bytes (736 bits) and 512-1247 is displayed in Outputs.

11. Click [Close].

Operation

When the CC-Link is installed, some operation differs from the other Fieldbus I/O options. This section describes about these differences.

Remote Input and Output

Remote input (RX) and remote output (RY) indicates ON/OFF information. Remote data is bit data and the FROM/TO command is executed per 16 bits (1 word).

“n” in the following tables is address configured as a master station with the station configure.

Remote Input List (Output from RC+ / Input for PLC)

(Version: ver2.00 / Extended Cyclic Setting: 2 / Input and Output Bytes: 92 (4 stations occupied)) *1

Signal direction: Remote device station (CC-Link board) → Master station (PLC)

Bits indicated as “NA” are left for user. Use these free for SPEL+ program.

Address	Signal Name		Controller Output Bit No.
RXn0	Ready	*1	512
RXn1	Start	*1	513
RXn2	Paused	*1	514
RXn3	Error	*1	515
RXn4	NA		516
RXn5	SafeguardOn	*1	517
RXn6	SError	*1	518
RXn7	Warning	*1	519
RXn8	MotorsOn	*1	520
RXn9	AtHome	*1	521
RXnA	CurrProg1	*1	522
RXnB	CurrProg2	*1	523
RXnC	CurrProg4	*1	524
RXnD	AutoMode	*1	525
RXnE	TeachMode	*1	526
RXnF	ErrorCode1	*1	527
RX(n+1)0	ErrorCode2	*1	528
RX(n+1)1	ErrorCode4	*1	529
RX(n+1)2	ErrorCode8	*1	530
RX(n+1)3	ErrorCode16	*1	531
RX(n+1)4	ErrorCode32	*1	532
RX(n+1)5	ErrorCode64	*1	533
RX(n+1)6	ErrorCode128	*1	534
RX(n+1)7	ErrorCode256	*1	535
RX(n+1)8	ErrorCode512	*1	536
RX(n+1)9	ErrorCode1024	*1	537
RX(n+1)A	ErrorCode2048	*1	538
RX(n+1)B	ErrorCode4096	*1	539
RX(n+1)C	ErrorCode8192	*1	540
RX(n+1)D	CmdRunning	*1	541
RX(n+1)E	CmdError	*1	542
RX(n+1)F	EStopOff	*1	543
RX(n+2)0	NA		544
:	:		

Address	Signal Name		Controller Output Bit No.
RX(n+D)8	NA		728
RX(n+D)9	NA		729
RX(n+D)A	NA		730
RX(n+D)B	Remote Ready	*2	731
RX(n+D)C	NA		732
RX(n+D)D	NA		733
RX(n+D)E	NA		734
RX(n+D)F	NA		735

*1: Remote control inputs and outputs are not allocated to fieldbus slave I/O by default. To allot remote control input and output to fieldbus slave I/O, refer to *3.5 Setting Remote Control Input and Output* later in this manual.

*2 When initialization of the CC-Link board is completed at the Controller turn-on, Remote Ready flag (in this example, [RX(n+D)B]) turns ON.
I/O assignment of Remote Ready cannot be changed or disabled (NA).

CC-Link Version	Number of Extended Cyclics	Number of Bytes Occupied Stations	Remote Ready Bit No.
1.10	/	1 to 12 (Occupied Stations 1)	539
		13 to 24 (Occupied Stations 2)	571
		25 to 36 (Occupied Stations 3)	603
		37 to 48 (Occupied Stations 4)	635
2.00	1×	12 (Occupied Stations 1)	539
		24 (Occupied Stations 2)	571
		36 (Occupied Stations 3)	603
		48 (Occupied Stations 4)	635
	2×	20 (Occupied Stations 1)	539
		44 (Occupied Stations 2)	603
		68 (Occupied Stations 3)	667
		92 (Occupied Stations 4)	731
	4×	40 (Occupied Stations 1)	571
		88 (Occupied Stations 2)	699
		136 (Occupied Stations 3)	827
		184 (Occupied Stations 4)	955
8×	80 (Occupied Stations 1)	635	
	176 (Occupied Stations 2)	891	

Remote Output List (Input for RC+ / Output from PLC) *1

(Version: ver2.00 / Extended Cyclic Setting: 2 / Input and Output Bytes: 92 (4 stations occupied)) *1

Signal direction: Master station (PLC) → Remote device station (CC-Link board)

Bits indicated as “NA” are left for user. Use these free for SPEL+ program.

Address	Signal Name		Controller Bit No
RYn0	Start	*1	512
RYn1	SelProg1	*1	513
RYn2	SelProg2	*1	514
RYn3	SelProg4	*1	515
RYn4	Stop	*1	516
RYn5	Pause	*1	517
RYn6	Continue	*1	518
RYn7	Reset	*1	519
RYn8	SetMotorsOn	*1	520
RYn9	SetMotorsOff	*1	521
RYnA	Home	*1	522
RYnB	Shutdown	*1	523
RYnC	NA		524
RYnD	NA		525
RYnE	NA		526
RYnF	NA		527
RY(n+1)0	NA		528
:	:		
RY(n+C)F	NA		719
RY(n+D)0	NA		720
RY(n+D)1	NA		721
RY(n+D)2	NA		722
RY(n+D)3	NA		723
RY(n+D)4	NA		724
RY(n+D)5	NA		725
RY(n+D)6	NA		726
RY(n+D)7	NA		727
RY(n+D)8	NA		728
RY(n+D)9	NA		729
RY(n+D)A	NA		730
RY(n+D)B	NA		731
RY(n+D)C	NA		732
RY(n+D)D	NA		733
RY(n+D)E	NA		734
RY(n+D)F	NA		735

*1: Remote control inputs and outputs are not allocated to fieldbus slave I/O by default. To allot remote control input and output to fieldbus slave I/O, refer to *3.5 Setting Remote Control Input and Output* later in this manual.

Remote Register

Remote register (RW_r, RW_w) is numeric value

“m” indicated in the following tables are master station address configured with station configure.

Remote Register List

(Version: ver2.00 / Extended Cyclic Setting: 2 / Input and Output Bytes: 92 (4 stations occupied)) *1

Signal direction: Remote device station (CC-Link board) → Master station (PLC)

Bits indicated as “NA” are left for user. Use these free for SPEL+ program.

Address	Signal Name	Controller Word No	Controller Bit No
RW _{rm} +0	NA	46	736~751
RW _{rm} +1	NA	47	752~767
:	:		
RW _{rm} +1D	NA	75	1200 to 1215
RW _{rm} +1E	NA	76	1216 to 1231
RW _{rm} +1F	NA	77	1232 to 1247

Signal direction: Master station (PLC) → Remote device station (CC-Link board)

Bits indicated as “NA” are left for user. Use these free for SPEL+ program.

Address	Signal Name	Controller Word No	Controller Bit No
RW _{wm} +0	NA	46	736~751
RW _{wm} +1	NA	47	752~767
:	:		
RW _{wm} +1D	NA	75	1200 to 1215
RW _{wm} +1E	NA	76	1216 to 1231
RW _{wm} +1F	NA	77	1232 to 1247

The number of stations, remote I/O range, and remote register range depend on the input / output size.

CC-Link Ver1.10

Input / Output Byte Configuration (RC+)	Occupied Stations	Remote I/O (Bytes)	Remote Register (Bytes)
$0 < x = < 4$	1	S	0
$4 < x = < 12$		4	$x - 4$
$12 < x = < 24$	2	8	$x - 8$
$24 < x = < 36$	3	12	$x - 12$
$36 < x = < 48$	4	16	$x - 16$

NOTE

When the input and output size of RC+ is set to 32 bytes (default value), number of occupied station will be 3, Remote I/O will be 12 bytes, Remote Register will be 20 bytes (10 words), and system reserved area will be 4 bytes.

When the input and output size is set to 36 bytes, number of occupied station will be 3, Remote I/O will be 12 bytes, Remote Register will be 24 bytes (12 words), and system reserved area will be 0 bytes.

In Version 2.00, there is no system reserved area.

CC-Link Ver2.00

Occupied Stations	Extended Cyclics							
	1x		2x		4x		8x	
1	12 bytes		20 bytes		40 bytes		80 bytes	
	32 bits	4 words	32 bits	8 words	64 bits	16 words	128 bits	32 words
2	24 bytes		44 bytes		88 bytes		176 bytes	
	64 bits	8 words	96 bits	16 words	192 bits	32 words	384 bits	64 words
3	36 bytes		68 bytes		136 bytes			
	96 bits	12 words	160 bits	24 words	320 bits	48 words		
4	48 bytes		92 bytes		184 bytes			
	128 bits	16 words	224 bits	32 words	448 bits	64 words		

The number of occupied stations is the ones on the CC-Link network. Set this number to the master station.

Remote I/O is the information of ON/OFF.

Remote I/O data is in bit data and the FROM/TO command are executed in units of 16 bits. Remote register is in numeric data.

Electronic Information File (CSP File, CSP+ File)

A CSP+ file is supplied for the CC-Link slave board network configuration.
The file is located in the following folder in where Epson RC+ 8.0 is installed.

C:\EpsonRC80\Fieldbus\CCLink

According to the Controller F/W version or input/output size, the CSP+ file you use differs.
See the table below and select the CSP+ file.

Firmware version	RC700 series	RC90 series
Ver.7.5.4.x or later	0x0353_EPSON RC700 CC-Link Slave_3_en.CSPP.zip	0x0353_EPSON RC90 CC-Link Slave_4_en.CSPP.zip

Compatibility

There is no change of the CC-Link slave board for supporting CC-Link Ver2.00. To use CC-Link Ver2.00, be sure to use RC+ with RC+ 7.5.4.x or later or Controller with firmware version 7.5.0.0 or later.



If the version of RC+ and Controller does not support CC-Link Ver2.00, available functions are limited to CC-Link Ver1.10.

Backup file compatibility

Backed up firmware version	Restored firmware version	Compatibility
7.5.0 or later (CC-Link Ver1.10 setting)	Before 7.5.4.x	Yes
7.5.4.x or later (CC-Link Ver2.00 setting)	Before 7.5.4.x	No (Set to 32 bytes which is default value of Ver1.10)

2.4.2 Installing CC-Link Slave Module



- Make sure that the power is turned OFF before installing/removing any modules or connecting/disconnecting any cables. Installing/removing any modules or connecting/disconnecting any cables with the power ON is extremely hazardous and may result in electric shock and/or malfunction of equipment.



- Pay attention to the followings in order to prevent the connector from coming off.
 1. Use the connectors attached to the module.
 2. Insert the connectors all the way seated.
 3. Fix the cables at proper positions in order not to put a load on the connectors.

Appearance

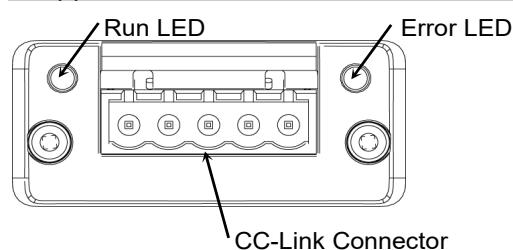

Specifications

Items	Specification	
Name	CC-Link Slave Module	
Connection Method	Broadcast polling	
Baud Rates (bps)	156 k, 625 k, 2.5 M, 5 M, 10 M (bps)	
Transfer Distance	Baud Rates	Cable Length
	10 M (bps)	100 m
	5 M (bps)	160 m
	2.5 M (bps)	400 m
	625 k (bps)	900 m
156 k (bps)	1200 m	
Maximum Device Number	64 units	
Cable	Dedicated cable supporting CC-Link Ver.1.10	
Mode	Slave	
Interface	1 CC-Link Ver1.10 / Ver2.00 port 1	
Occupied Stations	1 to 4 station(s) (Remote device station)	
Master Station's Handshake		
Max. Input Data Size (Ver1.10)	384 bits (48 bytes)	
Max. Input Data Size (Ver2.00)	RC800 series	T/VT series
	2944 bits (368 bytes)	1472 bits (184 bytes)
Max. Output Data Size (Ver1.10)	384 bits (48 bytes)	
Max. Output Data Size (Ver2.00)	RC800 series	T/VT series
	2944 bits (368 bytes)	1472 bits (184 bytes)

LED Description

LED state represents the states of the fieldbus I/O module.

LED	State	
Run LED	OFF	No network participation, timeout state (no power)
	Green	Participating, normal operation
	Red	Major fault (FATAL error)
Error LED	OFF	No error detected (no power)
	Red	Major fault (Exception or FATAL event)
	Red, blinking	CRC error (temporary flickering)
	Red, ON	Station Number or Baud rate has changed since startup (flashing)

Wiring

The CC-Link connector is a 5-pin open connector. Use the connector attached to the module for wiring.

Terminal name for each pin

Terminal No	Terminal Name
1	DA
2	DB
3	DG
4	SLD
5	FG

Connect the CC-Link master module and the CC-Link slave module as follows.

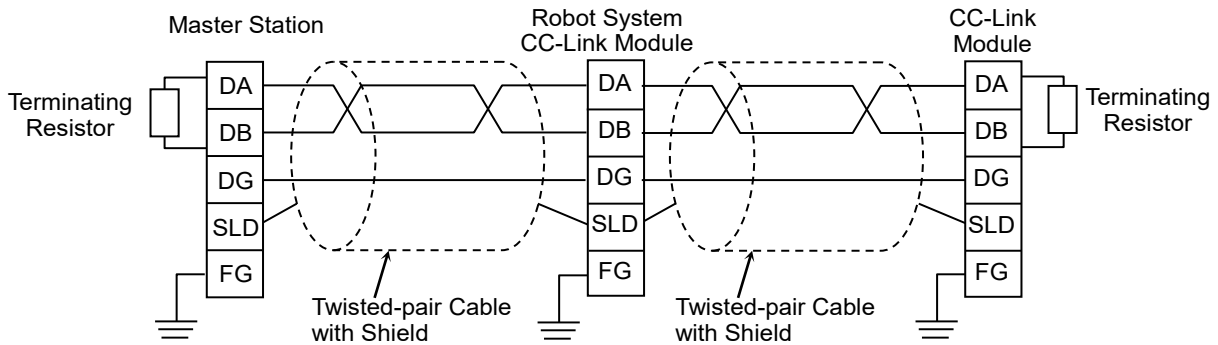

Prepare the cable for CC-Link Ver.1.10 sold in the market as a communication cable. Install terminating resistors at both ends of the network. Use the terminating resistors attached to the CC-Link master station.

Make sure to disconnect the connectors only after turning OFF the power supply of the specific station.

Connect the shield wire for CC-Link to the “SLD” of each unit and ground the both ends via “FG”.

Installing Module



- Make sure that the power is turned OFF before installing/removing any modules or connecting/disconnecting any cables. Working with the power ON is extremely hazardous and may result in electrical shock and/or malfunction of equipment.

Install the module to the dedicated slot on the Controller.

Reference manuals:

T series MAINTENANCE MANUAL 14.6 Fieldbus I/O

T-B series MAINTENANCE MANUAL 14.5 Fieldbus I/O

VT series MAINTENANCE MANUAL 18.7 Fieldbus I/O

RC800 series Service Manual 4.1.3 Fieldbus I/O Module

Compliance with the EMC regulations

Our robot controllers and optional CC-Link boards are built into mechanical devices.

EMC compliance with your end product (entire mechanical device which builds our products into the device) varies depending on configuration, wiring, placement, and so on. Therefore, please judge the EMC compliance of your final product by yourself.

An example of EMC countermeasures is described below.

- Mount a ferrite core to the CC-Link cable to reduce radiation noise.
- Use the exclusive cable for CC-Link.
- Place the ferrite core as close as possible to the controller.
- Change the number of the cable turns to the ferrite core depending on the radiation noise condition.
- Use the ferrite core listed in the table below or equivalent.

Manufacturer	Part number
Kitagawa Industries Co., LTD.	GTFC-41-27-16



- This example is an idea of the EMC countermeasures in our installation and wiring conditions. The test result may vary in your testing environment.

Confirmation of Epson RC+ 8.0

When the CC-Link slave module is installed to the Controller, it is recognized automatically. Confirm whether Epson RC+ 8.0 has recognized the CC-Link module using the following procedure.

2. Installation

1. Select [Setup]-[System Configuration] and display the [System Configuration] dialog box.
2. Select [Controller]-[Inputs / Outputs].

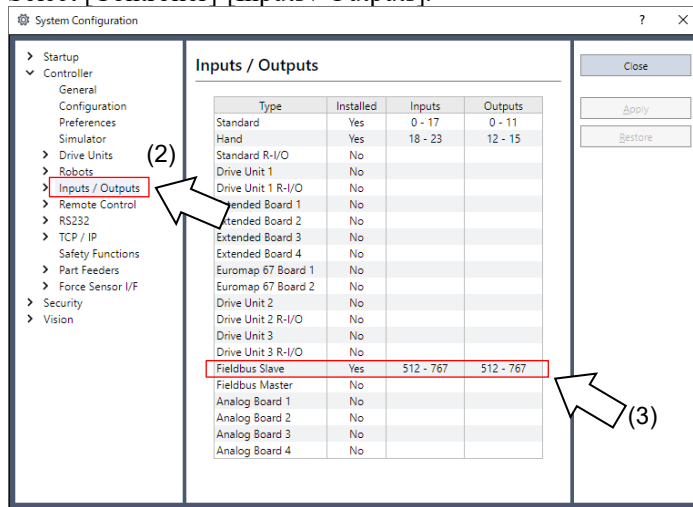

3. Confirm that the following items are displayed in “Fieldbus Slave”.

Installed : Yes
 Inputs : 512-767 (default setting)
 Outputs : 512-767 (default setting)

4. Select [Fieldbus Slave]-[General].

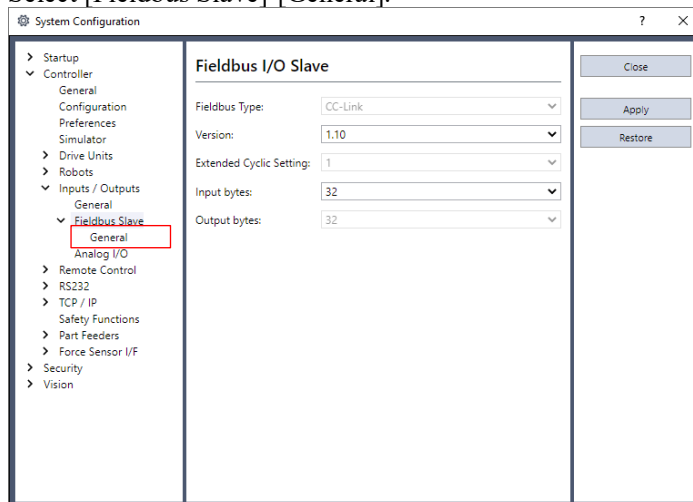

5. Set each item to the specific value to connect the CC-Link network.
For information about the setting values, contact your network administrator.
6. Click [Close].



These is no Extended Cyclic Setting on CC-Link Ver1.10.
 If you change Version to 2.00, you can configure Extended Cyclic Setting.

Editing of Input / Output Size

You can change the input/output size of the CC-Link slave module if necessary.

- 1 Select [Setup]-[System Configuration] and display the [System Configuration] dialog box.
- 2 Select [Controller]-[Inputs / Outputs]-[Fieldbus Slave]-[General].

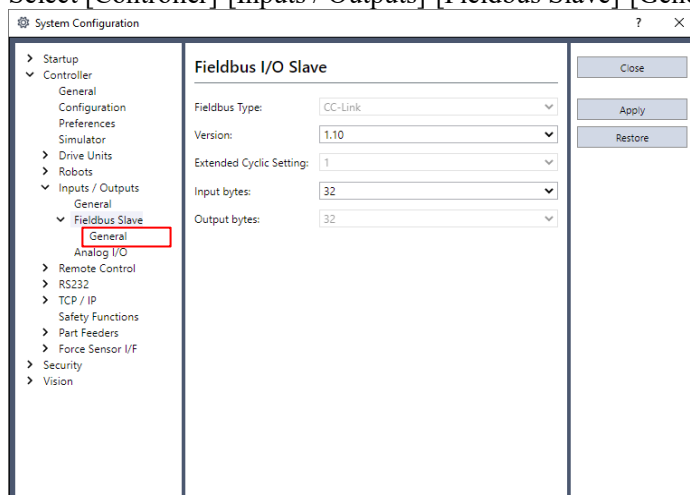

- 3 Change the settings of [Version] of CC-Link.
In this example, Version is changed to “2.00”.

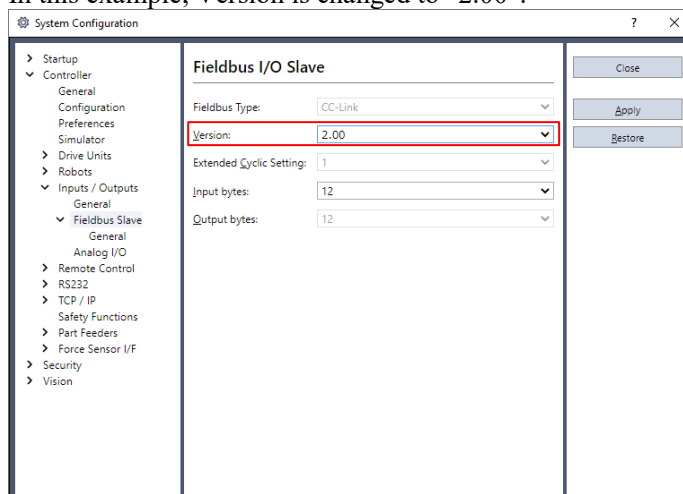

- 4 Change the settings of [Extended Cyclic Setting].
In this example, Extended Cyclic Setting is changed to “2”.

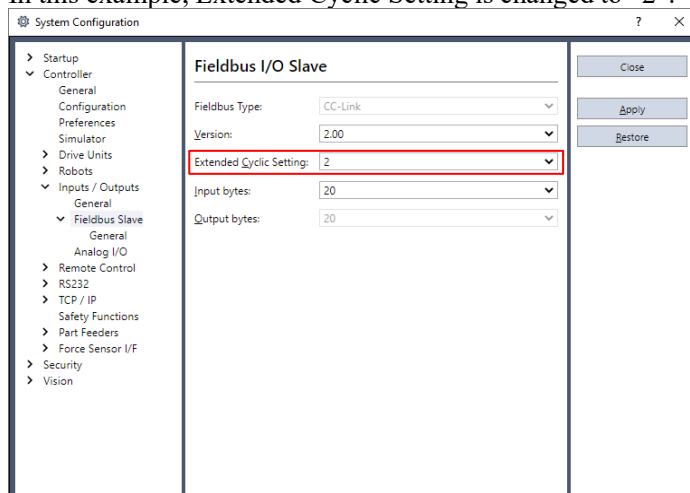

- Change the settings of [Input Bytes] and [Output Bytes].
In this example, both of them are changed to “92” Bytes.

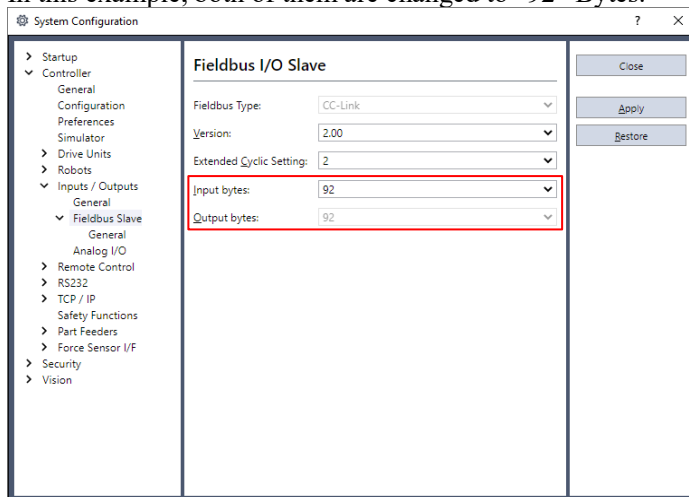

- Click [Apply].
- Click [Close].
The following dialog box appears and the Controller automatically starts rebooting.



- Select [Setup]-[System Configuration] and display the [System Configuration] dialog box.
- Select [Controller]-[Inputs / Outputs].

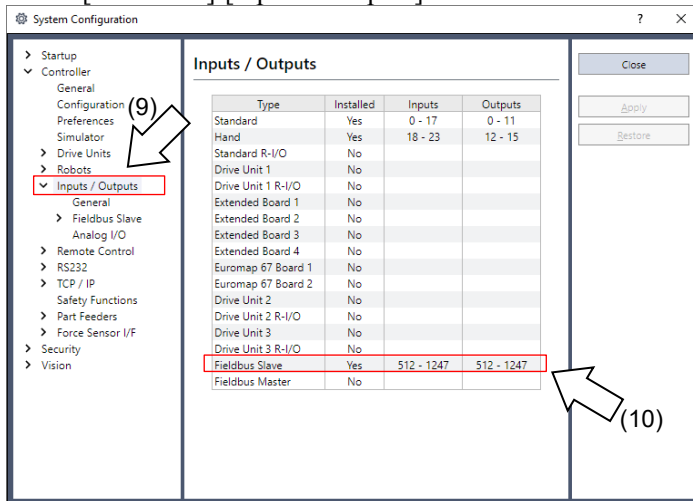

- Confirm that the following items are displayed in “Fieldbus Slave”.

Inputs : 512 – 1247

Outputs : 512 – 1247

In this example, Input byte is 92 bytes (736 bits) and 512-1247 is displayed in Inputs.

Also, Output byte is 92 bytes (736 bits) and 512-1247 is displayed in Outputs.

- Click [Close].

Operation

When the CC-Link is installed, some operation differs from the other Fieldbus I/O options. This section describes about these differences.

Remote Input / Output

Remote input (RX) and remote output (RY) indicates ON/OFF information. Remote data is bit data and the FROM/TO command is executed per 16 bits (1 word).

“n” in the following tables is address configured as a master station with the station configure.

Remote Input List (Output from RC+ / Input for PLC) *1

(Version: ver2.00 / Extended Cyclic Setting: 2 / Input and Output Bytes: 92 (4 stations occupied)) *1

Signal direction: Remote device station (CC-Link module) → Master station (PLC)

Bits indicated as “NA” are left for user. Use these free for SPEL+ program.

Address	Signal Name		Robot System Output Bit No.
RXn0	Ready	*1	512
RXn1	Running	*1	513
RXn2	Paused	*1	514
RXn3	Error	*1	515
RXn4	NA		516
RXn5	SafeguardOn	*1	517
RXn6	SError	*1	518
RXn7	Warning	*1	519
RXn8	MotorsOn	*1	520
RXn9	AtHome	*1	521
RXnA	CurrProg1	*1	522
RXnB	CurrProg2	*1	523
RXnC	CurrProg4	*1	524
RXnD	AutoMode	*1	525
RXnE	TeachMode	*1	526
RXnF	ErrorCode1	*1	527
RX(n+1)0	ErrorCode2	*1	528
RX(n+1)1	ErrorCode4	*1	529
RX(n+1)2	ErrorCode8	*1	530
RX(n+1)3	ErrorCode16	*1	531
RX(n+1)4	ErrorCode32	*1	532
RX(n+1)5	ErrorCode64	*1	533
RX(n+1)6	ErrorCode128	*1	534
RX(n+1)7	ErrorCode256	*1	535
RX(n+1)8	ErrorCode512	*1	536
RX(n+1)9	ErrorCode1024	*1	537
RX(n+1)A	ErrorCode2048	*1	538
RX(n+1)B	ErrorCode4096	*1	539
RX(n+1)C	ErrorCode8192	*1	540
RX(n+1)D	CmdRunning	*1	541
RX(n+1)E	CmdError	*1	542
RX(n+1)F	EStopOff	*1	543
RX(n+2)0	NA		544
:	:		

Address	Signal Name		Robot System Output Bit No.
RX(n+D)8	NA		728
RX(n+D)9	NA		729
RX(n+D)A	NA		730
RX(n+D)B	Remote Ready	*2	731
RX(n+D)C	NA		732
RX(n+D)D	NA		733
RX(n+D)E	NA		734
RX(n+D)F	NA		735

*1: Remote control inputs and outputs are not allocated to fieldbus slave I/O by default. To allot remote control input and output to fieldbus slave I/O, refer to *3.5 Setting Remote Control Input and Output* later in this manual.

*2: When initialization of the CC-Link module is completed at the Robot system turn-on, Remote Ready flag (In this example [RX(n+F)B] turns ON.
I/O assignment of Remote Ready cannot be changed or disabled (NA).

CC-Link Version	Number of Extended Cyclics	Number of Bytes (Occupied Stations)	Remote Ready Bit No.
1.10	/	1 to 12 (Occupied Stations 1)	539
		13 to 24 (Occupied Stations 2)	571
		25 to 36 (Occupied Stations 3)	603
		37 to 48 (Occupied Stations 4)	635
2.00	1×	12 (Occupied Stations 1)	539
		24 (Occupied Stations 2)	571
		36 (Occupied Stations 3)	603
		48 (Occupied Stations 4)	635
	2×	20 (Occupied Stations 1)	539
		44 (Occupied Stations 2)	603
		68 (Occupied Stations 3)	667
		92 (Occupied Stations 4)	731
	4×	40 (Occupied Stations 1)	571
		88 (Occupied Stations 2)	699
		136 (Occupied Stations 3)	827
		184 (Occupied Stations 4)	955
	8×	80 (Occupied Stations 1)	635
		176 (Occupied Stations 2)	891
		272 (Occupied Stations 3)	1147
		368 (Occupied Stations 4)	1403

Remote Output List (Input for RC+ / Output from PLC) *1

(Version: ver2.00 / Extended Cyclic Setting: 2 / Input and Output Bytes: 92
(4 stations occupied)) *1

Signal direction: Master station (PLC) → Remote device station (CC-Link module)

Bits indicated as “NA” are left for user. Use these free for SPEL+ program.

Address	Signal Name		Robot System Bit No.
RYn0	Start	*1	512
RYn1	SelProg1	*1	513
RYn2	SelProg2	*1	514
RYn3	SelProg4	*1	515
RYn4	Stop	*1	516
RYn5	Pause	*1	517
RYn6	Continue	*1	518
RYn7	Reset	*1	519
RYn8	SetMotorsOn	*1	520
RYn9	SetMotorsOff	*1	521
RYnA	Home	*1	522
RYnB	Shutdown	*1	523
RYnC	NA		524
RYnD	NA		525
RYnE	NA		526
RYnF	NA		527
RY(n+1)0	NA		528
:	:		
RY(n+C)F	NA		719
RY(n+D)0	NA		720
RY(n+D)1	NA		721
RY(n+D)2	NA		722
RY(n+D)3	NA		723
RY(n+D)4	NA		724
RY(n+D)5	NA		725
RY(n+D)6	NA		726
RY(n+D)7	NA		727
RY(n+D)8	NA		728
RY(n+D)9	NA		729
RY(n+D)A	NA		730
RY(n+D)B	NA		731
RY(n+D)C	NA		732
RY(n+D)D	NA		733
RY(n+D)E	NA		734
RY(n+D)F	NA		735

*1: Remote control inputs and outputs are not allocated to fieldbus slave I/O by default. To allot remote control input and output to fieldbus slave I/O, refer to 3.5 *Setting Remote Control Input and Output* later in this manual.

Remote Register

Remote register (RW_r, RW_w) is numeric value

“m” indicated in the following tables are master station address configured with station configure.

Remote Register List

(Version: ver2.00 / Extended Cyclic Setting: 2 / Input and Output Bytes: 92

(4stations occupied)) *1

Signal direction: Remote device station (CC-Link module) → Master station (PLC)

Bits indicated as “NA” are left for user. Use these free for SPEL+ program.

Address	Signal Name	Robot System Word No	Robot System Bit No
RW _{rm} +0	NA	46	736~751
RW _{rm} +1	NA	47	752~767
:	:		
RW _{rm} +1D	NA	75	1200 to 1215
RW _{rm} +1E	NA	76	1216 to 1231
RW _{rm} +1F	NA	77	1232 to 1247

Signal direction: Master station (PLC) → Remote device station (CC-Link module)

Bits indicated as “NA” are left for user. Use these free for SPEL+ program.

Address	Signal Name	Robot System Word No	Robot System Bit No
RW _{wm} +0	NA	46	736~751
RW _{wm} +1	NA	47	752~767
:	:		
RW _{wm} +1D	NA	75	1200 to 1215
RW _{wm} +1E	NA	76	1216 to 1231
RW _{wm} +1F	NA	77	1232 to 1247

The number of stations, remote I/O range, and remote register range depend on the input / output size.

CC-Link Ver1.10

Input / Output Byte Configuration (RC+)	Occupied Stations	Remote I/O (Bytes)	Remote Register (Bytes)
$0 < x = < 4$	1	S	0
$4 < x = < 12$		4	$x - 4$
$12 < x = < 24$	2	8	$x - 8$
$24 < x = < 36$	3	12	$x - 12$
$36 < x = < 48$	4	16	$x - 16$



When the input and output size of RC+ is set to 32 bytes (default value), number of occupied station will be 3, Remote I/O will be 12 bytes, Remote Register will be 20 bytes (10 words), and system reserved area will be 4 bytes.

When the input and output size is set to 36 bytes, number of occupied station will be 3, Remote I/O will be 12 bytes, Remote Register will be 24 bytes (12 words), and system reserved area will be 0 bytes.

In Version 2.00, there is no system reserved area.

CC-Link Ver2.00

Occupied Stations	Extended Cyclics							
	1x		2x		4x		8x	
1	12 bytes		20 bytes		40 bytes		80 bytes	
	32 bits	4 words	32 bits	8 words	64 bits	16 words	128 bits	32 words
2	24 bytes		44 bytes		88 bytes		176 bytes	
	64 bits	8 words	96 bits	16 words	192 bits	32 words	384 bits	64 words
3	36 bytes		68 bytes		136 bytes		272 bytes	
	96 bits	12 words	160 bits	24 words	320 bits	48 words	640 bits	96 words
4	48 bytes		92 bytes		184 bytes		368 bytes	
	128 bits	16 words	224 bits	32 words	448 bits	64 words	896 bits	128 words

The number of occupied stations is the ones on the CC-Link network. Set this number to the master station.

Remote I/O is the information of ON/OFF.

Remote I/O data is in bit data and the FROM/TO command are executed in units of 16 bits. Remote register is in numeric data.

Electronic Information File (CSP+ File)

A CSP+ file is supplied for the CC-Link slave module network configuration. The file is located in the following folder in where Epson RC+ 8.0 is installed.

C:\EpsonRC80\Fieldbus\CCLink

According to the Controller F/W version, the CSP+ file you use differs.
See the table below and select the CSP+ file.

CSP+ File Table

Controller	File name
RC800 series	0x0353_EPSON RC800_1_en.CSPP.zip
T/VT series	0x0353_EPSON T series_3_en.CSPP.zip

Compatibility

There is no change of the CC-Link slave module for supporting CC-Link Ver2.00. To use CC-Link Ver2.00, be sure to use RC+ with RC+ 7.5.0 or later or Controller with firmware version 7.5.0.0 or later.



If the version of RC+ and Controller does not support CC-Link Ver2.00, available functions are limited to CC-Link Ver1.10.

Backup file compatibility

Backed up firmware version	Restored firmware version	Compatibility
7.5.54.x or later (CC-Link Ver1.10 setting)	Before 7.5.0	Yes
7.5.54.x or later (CC-Link Ver2.00 setting)	Before 7.5.0	No (Set to 32 bytes which is default value of Ver1.10)

2.5 PROFINET



- Make sure that the power is turned OFF before installing/removing any boards or connecting/disconnecting any cables. Installing/removing any boards or connecting/disconnecting any cables with the power ON is extremely hazardous and may result in electric shock and/or malfunction of equipment.

2.5.1 Installing a PROFINET Board Manufactured by Hilscher

Appearance

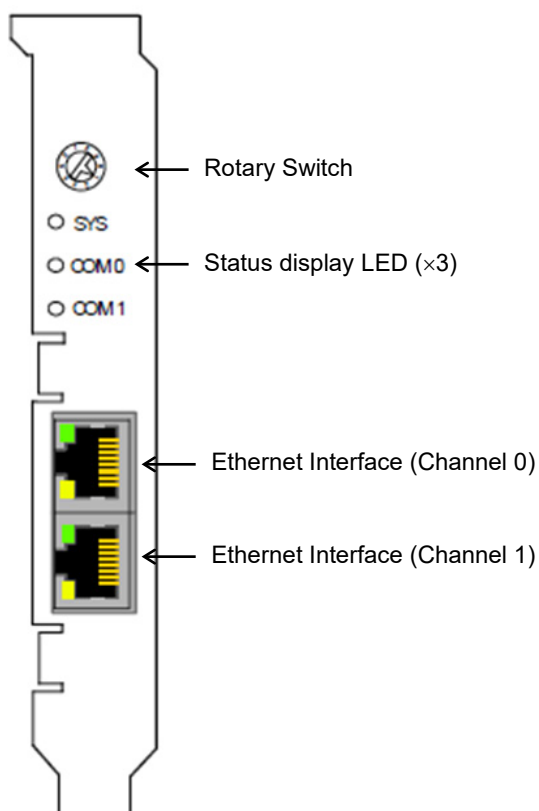

PCI: CIFX 50-RE

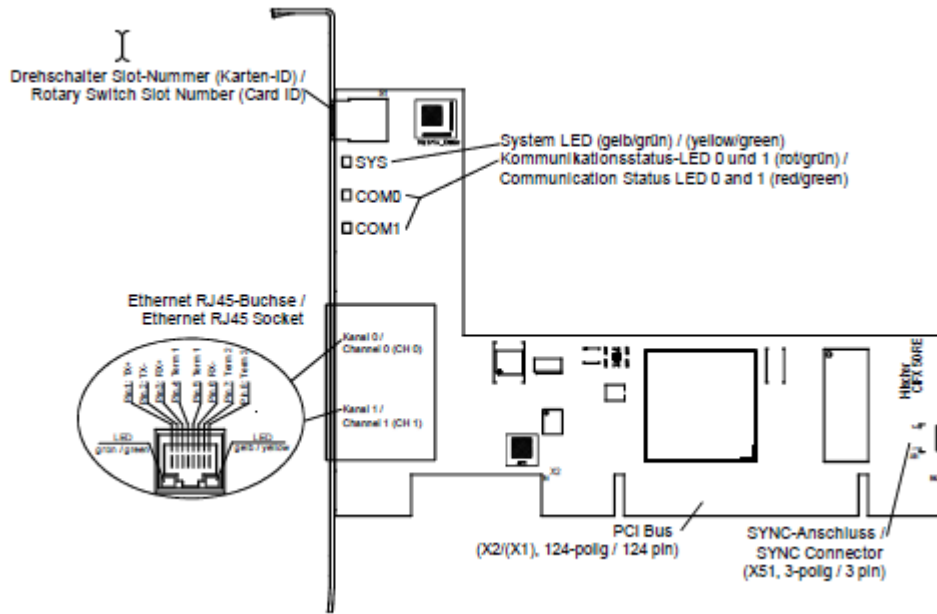

PCI Express: CIFX 50E-RE

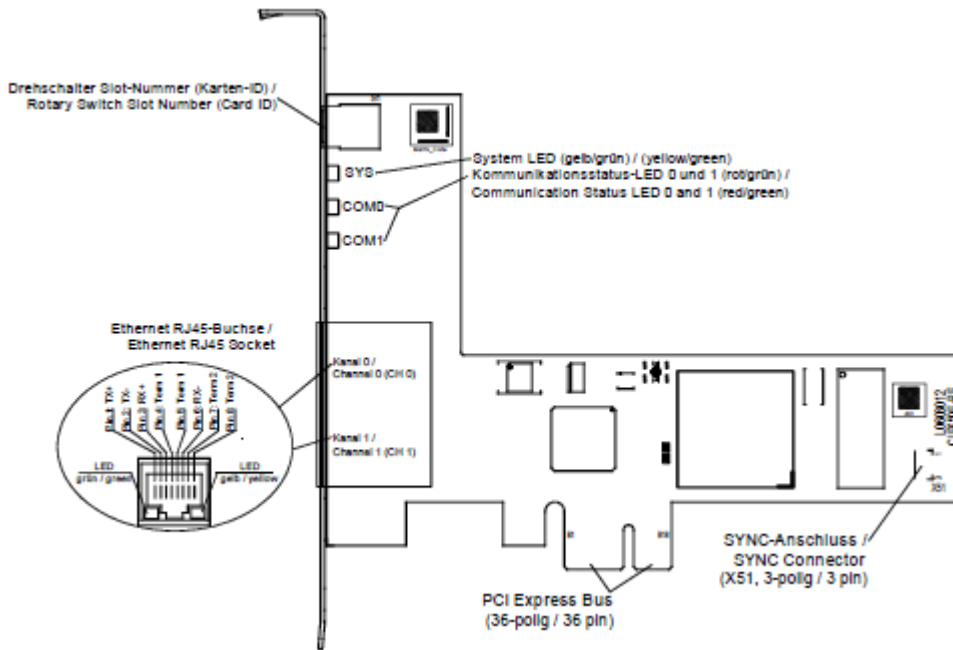

Specifications







PROFINET IO-Controller (V3)

Item	Specification
Name	PROFINET Board Manufactured by Hilscher
Maximum number of ARs (Application Relations)	128 for RT communication 64 for IRT communication
Maximum amount of cyclic input data (all nodes)	5652 bytes, including provider and consumer status
Maximum amount of cyclic input data (all nodes)	5700 bytes, including provider and consumer status
Send clock	1ms, 2ms, 4ms for RT mode 250 μ s, 500 μ s, 1 ms, 2 ms, 4 ms for IRT mode
Performance limits of ARs	Max. 8 ARs, if a send clock < 500 μ s Max. 16 ARs, if a send clock < 1 ms Max. 64 ARs, if a send clock < 2 ms
Maximum number of submodule	2048
Maximum amount of data per IOCR	1440 bytes
Number of IOCRs per AR	1 Input IOCR 1 Output IOCR
Maximum amount of data for acyclic read/write record access	65536 bytes
Maximum amount of record data per AR	16384 bytes
Alarm processing (configurable)	Stack processes alarms automatically Application processes alarms
Maximum number of ARVendorBlock	256
Maximum size of ARVendorBlockData	512 bytes
Device Access AR CMI Timeout	20 s
Functions	Automatic Name Assignment Media Redundancy Client Media Redundancy Manager (requires license)
DCP function API	Name Assignment IO-Devices (DCP SET NameOfStation) Set IO-Devices IP (DCP SET IP) Signal IO-Device (DCP SET SIGNAL) Reset IO-Device to factory settings (DCP Reset FactorySettings) Bus scan (DCP IDENTIFY ALL) DCP GET





PROFINET specification	<p>Implemented according to V2.3 ED2 MU3</p> <p>Legacy Startup supported according to PROFINET specification V2.2</p>
Limitations	<p>The size of the bus configuration file is limited by the size of the RAM Disk (1 Mbyte)</p> <p>The usable (minimum) cycle time depends on the number of IO Devices used, and the amount of input and output data used.</p> <p>RT over UDP is not supported</p> <p>Multicast communication is not supported</p> <p>DHCP is not supported (neither for PROFIT IO Controller nor for IO-Devices)</p> <p>Only one IOCR per IO-Device per direction.</p> <p>Only one instance of Device Access AR can be used at a time.</p> <p>MRPD is not supported.</p> <p>Planning of IRT is not done by the PROFINET IO Controller protocol stack</p> <p>Sync Slave is not supported</p> <p>Only one fragmented acyclic service can be used at a time.</p> <p>Multiple MRP Managers are not supported</p> <p>One DCP Service can be used in parallel only</p> <p>Multiple Sync Masters are not supported</p>
Reference to firmware / stack version	V3.3

LED Description

For the PROFINET IO Controller protocol, the system status LED SYS, communication LED SF (System Failure), BF (Bus Failure), ethernet LED Link or RX/TX can assume the states described below.

SYS	SF	BF	Meaning
System status Yellow/green	System Failure COM0 red/green	Bus Failure COM1 red/green	LED name General LED name Colors of the SYS and SF LEDs, or of BF
Firmware and Configuration			
● Off	● Off	● Off	Power supply for the device is missing, or there is a hardware defect.
● On, yellow	● Off	● Off	No second stage bootloader found in Flash memory.
 Flashing, green/yellow, cyclic	● Off	● Off	No firmware file found in Flash file system.
● On, green	● On, red	● Off	PROFINET IO Controller is not configured
● On, green	● Off	● On, red	No Ethernet port has a link. E.g., no cable connected to any of the Ethernet ports.
● On, green	● Off	 Flashing, red, 2Hz	PROFINET IO Controller is not online (the bus is turned OFF).
PROFINET communication			
● On, green	● Off or ● On, red	 Flashing, red, 1 Hz	Not all configured devices are in data exchange.
● On, green	● On, red	-	One IO Device connected to the PROFINET IO Controller reports a problem.
● On, green	● Off	● Off	All devices are in data exchange and no problem has been reported by any device.
PROFINET IO Controller operation			
● On, green	 Flashing, red, 1 Hz, 3s	● Off	PROFINET DCP Set Signal has been received.
● On, green	 Flashing, red 2 Hz,	 Flashing, red, 2 Hz,	The PROFINET IO Controller has detected an address conflict. Another device in the network is using the same Station name or IP address as the PROFINET IO Controller. This could also be a Watchdog error
● On, green	● On, red	● On, red	No valid Master license

2. Installation

LED	Color	State	Meaning
LINK Ch0 & Ch1	LED green		
	 green	On	The device is linked to the Ethernet
	 off	Off	The device has no link to the Ethernet
RX/TX Ch0 & Ch1	LED yellow		
	 yellow	Flickering (load dependent)	The device sends/receives Ethernet frames.
	 off	Off	The device does not send/receive Ethernet frames.

LED state	Definition
Flashing (1 Hz, 3 s)	The indicator turns on and off for 3 seconds with a frequency of 1 Hz: "on" for 500 ms, followed by "off" for 500 ms.
Flashing (1 Hz)	The indicator turns on and off with a frequency of 1 Hz: "on" for 500 ms, followed by "off" for 500 ms.
Flashing (2 Hz)	The indicator turns on and off with a frequency of 2 Hz: "on" for 250 ms, followed by "off" for 250 ms.
Flickering (load dependent)	The indicator turns on and off with a frequency of approximately 10 Hz to indicate high Ethernet activity: on for approximately 50 ms, followed by off for 50 ms. The indicator turns on and off at irregular intervals to indicate low Ethernet activity.

Modes

The Hilscher PROFINET board has two operating modes: master mode and slave mode, but do not set it to slave mode.

Master mode

It brings together and manages each node connected to the PROFINET network.

A PROFINET master can manage 128 devices for RT communication and 64 devices for IRT communication (up to 128 bytes of data).

Usually, the PLC acts as the master and manages each node, but the EPSON RC+ can also act as the master.

Set up the PROFINET network configuration in the configurator (Hilscher SYCON.net).

Setting parameters for each slave device

This is managed in an electronic information file (GSDML file) and is recognized by the configurator via this file.

The communication speed (bps) is 100 Mbps.

Installing Software

Installing device driver

Before adding PROFINET board manufactured by Hilscher to the PC with Epson RC+ 8.0 installed, you must install the Hilscher SYCON.net application and drivers according to the type of the board you are using.

- (1) Insert the Communication-Solutions DVD into the PC with Epson RC+ 8.0 installed.
- (2) Open the [Communication-Solutions DVD \Driver_&_Toolkit\Device Driver (NXDRV-WIN)\Installation] folder of the Communication-Solutions DVD. Click cifX Device Driver Setup.exe.
- (3) The [User Account Control] dialog box appears. Click [Yes].

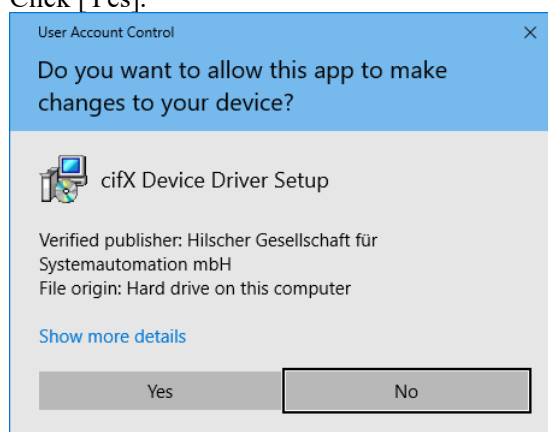

- (4) The [Device Driver Setup] dialog box appears. Select the [I accept the terms in the License Agreement] check box. Click [Install].

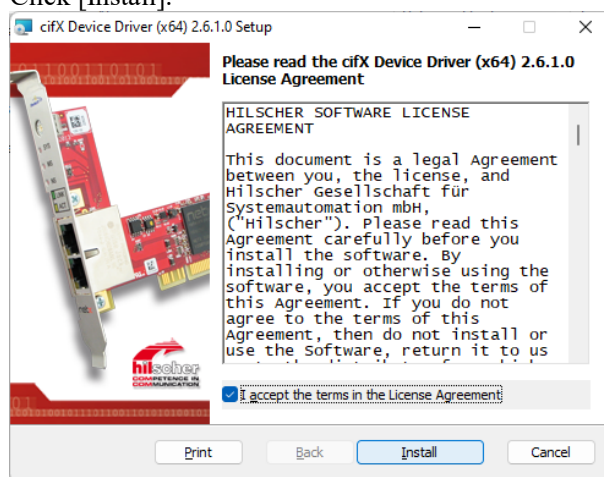

- (5) The [Windows Security] dialog box appears. Click [Install].
- (6) When the dialog box changes, click [Install] again.

- (7) The [Completed the cifX Device Driver (x64) 2.6.1.0 Setup Wizard] dialog box appears.
Click [Finish].



Installing master application software

- (1) Open the [Communication-Solutions DVD\Software_&_Tools\Configuration_Software\SYCON.net] folder of the Communication-Solutions DVD.
Execute SYCONnet netX setup.exe.
- (2) When Windows Security Alert appears, do not click [Cancel] and proceed to the next step.
- (3) The [User Account Control] dialog box appears.
Click [Yes].

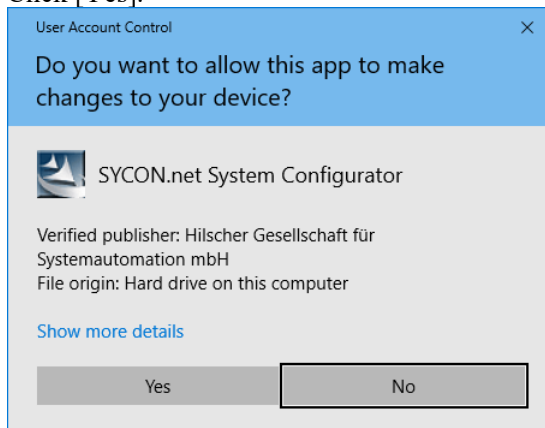

- (4) [Choose Setup Language] dialog box appears.
Select "English [USA]" and click [OK].

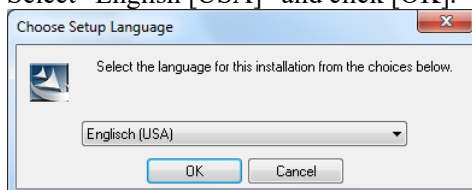

Now, the installation will begin.

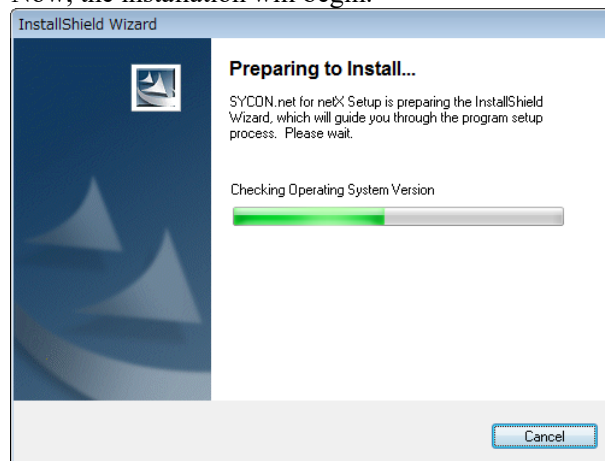

- (5) The [InstallShield Wizard - Welcome] dialog box appears. Click [Next].

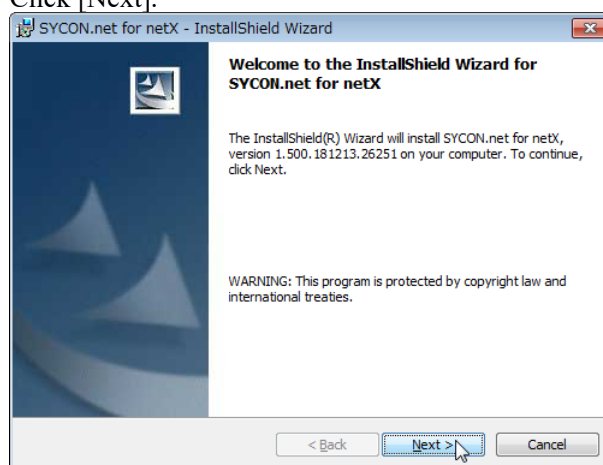

- (6) The [InstallShield Wizard - Important Information] dialog box appears. Select [I read the information]. Click [Next].

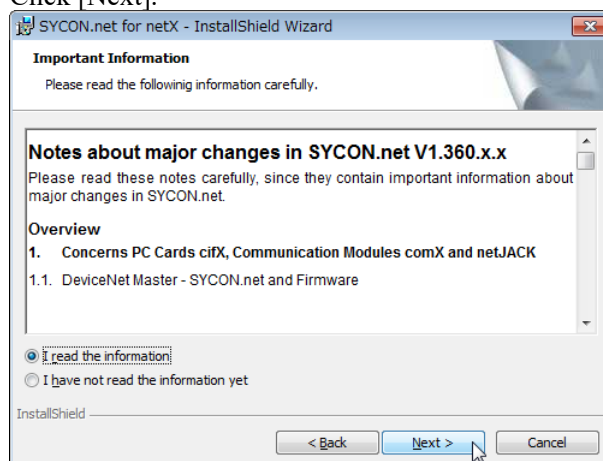

2. Installation

- (7) The [InstallShield Wizard - License Agreement] dialog box appears. Select [I accept the terms in the license agreement]. Click [Next].

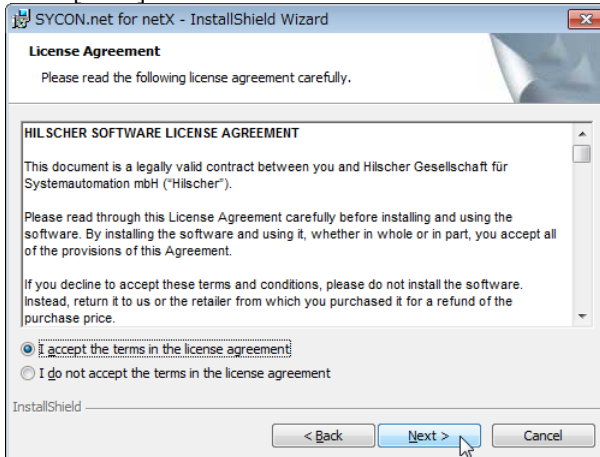

- (8) The [InstallShield Wizard - Customer Information] dialog box appears. Enter the User Name and Organization. Click [Next].

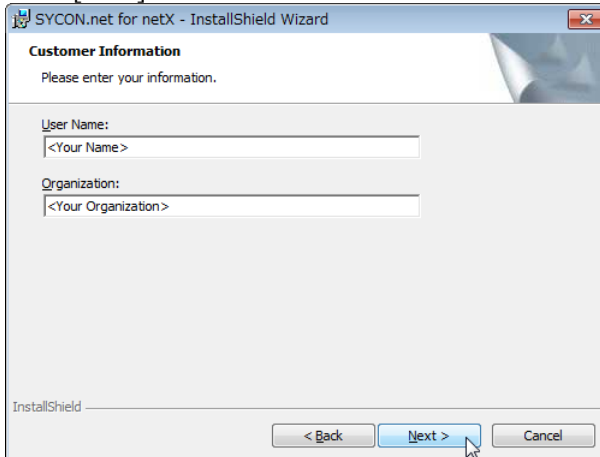

- (9) The [InstallShield Wizard - Ready to Install the Program] dialog box appears. Click [Install].

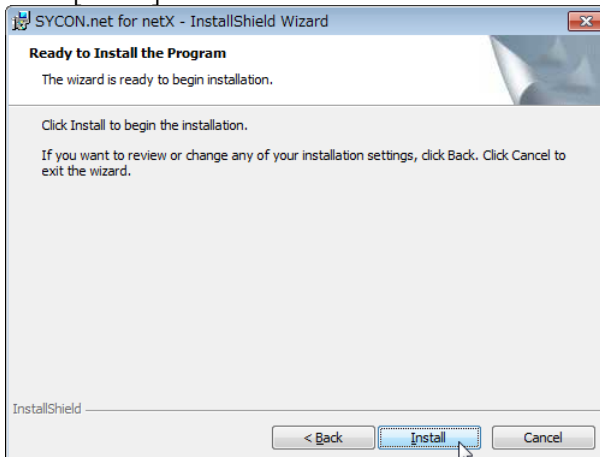

Now, the installation begins.

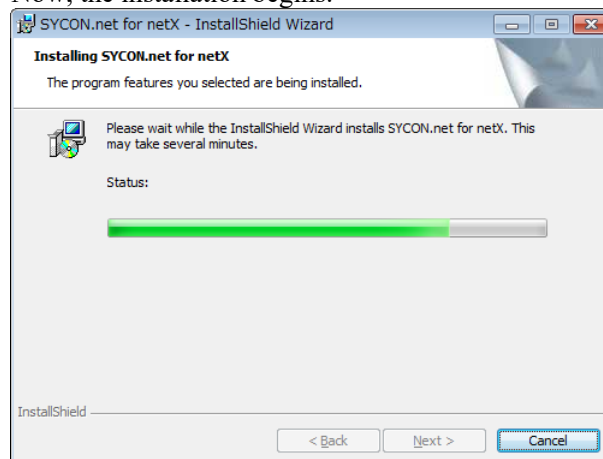

- (10) The [InstallShield Wizard - InstallShield Wizard Completed] dialog box appears. Click [Finish].

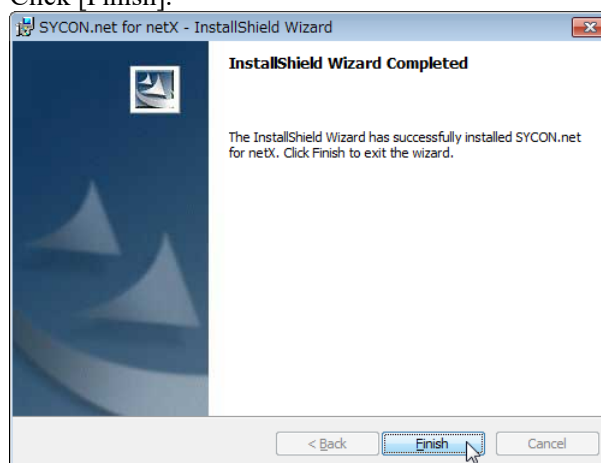

Refer to the next section, “Installing a Board,” and install the PROFINET board manufactured by Hilscher.

Installing a Board

- (1) Configure the rotary switch of the board address on the PROFINET board manufactured by Hilscher. You can install one fieldbus master board to the PC with Epson RC+ 8.0 installed. The slot number should be “Not in use (0)”. Refer to the following table for configuration.

Slot No.	Rotary switch position
Not in use	0
Slot No. 1	1
Slot No. 9	9

- (2) Install the PROFINET board manufactured by Hilscher to the PCI bus or PCI Express bus of the PC with Epson RC+ 8.0 installed.
Depending on the type of PC, the way to install the Hilscher PROFINET board to the PCI bus/PCI Express bus and how to open the cover will differ. Refer to the manuals of each PC for information on how to install the board to the PCI bus/PCI Express board.
- (3) Connect the PROFINET board manufactured by Hilscher to the PROFINET network.

2. Installation

- (4) Start up the PC.
- (5) Select the Start menu-[SYCON.net] and execute it.

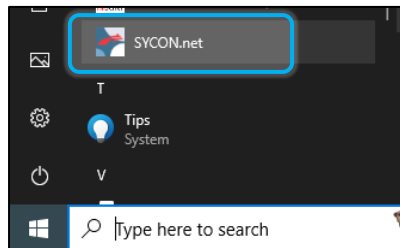

- (6) Set an Administrator password for SYCON.net.
Click [OK].
Be careful not to forget the Administrator password.

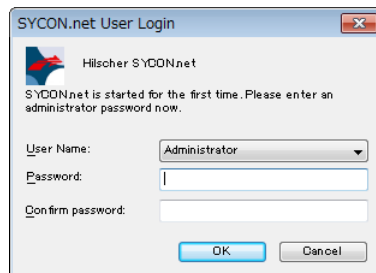

- (7) SYCON.net starts up.
Click the Device Catalog list to the right of [netDevice].

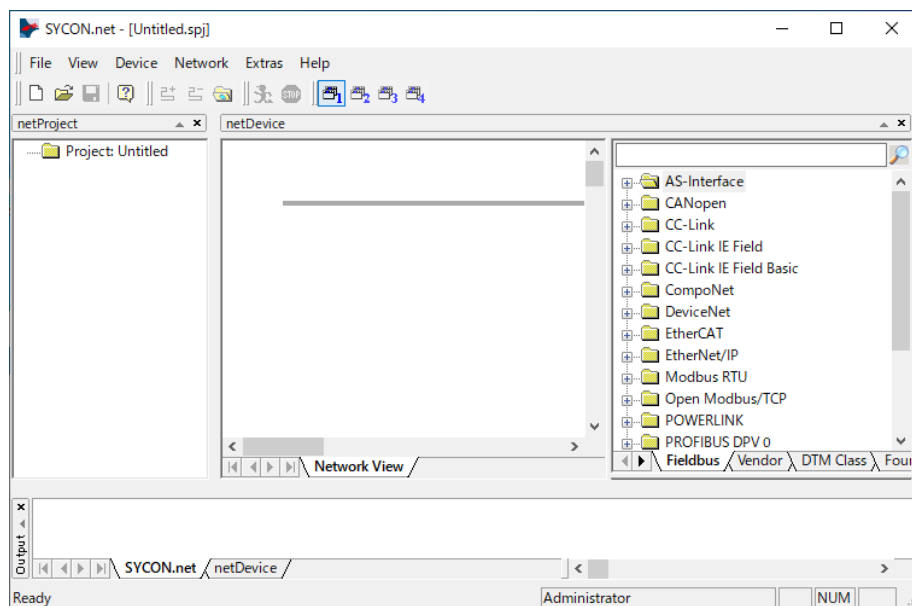

Importing slave GSDML (*.xml) files

- (8) Click [Network]-[Import Device Descriptions...].

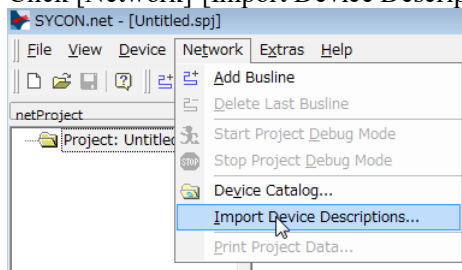

The [Import Device Description] dialog box appears.

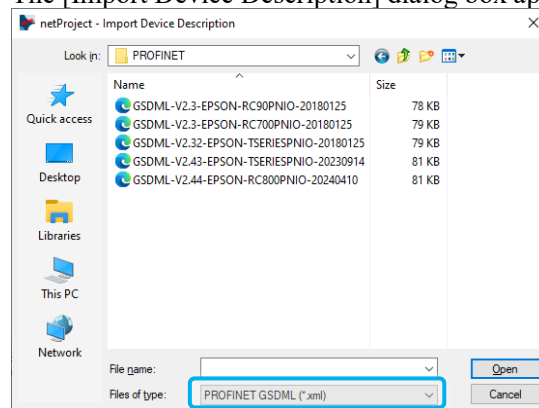

From [Files of type], select PROFINET GSDML (*.xml)

- (9) Select the GSDML (*.xml) files provided by each device manufacturer and click [Open].

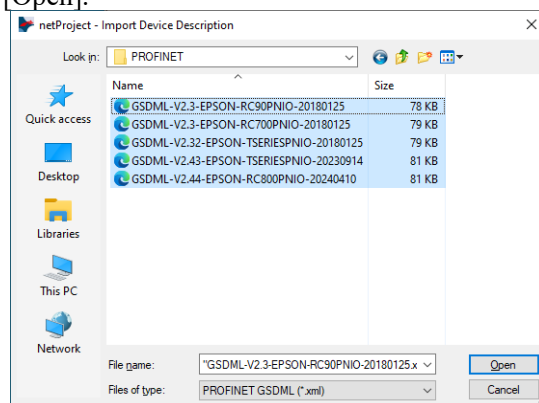

2. Installation

- (10) The following message appears.
Click [Yes]. The GSDML (*.xml) files are imported.

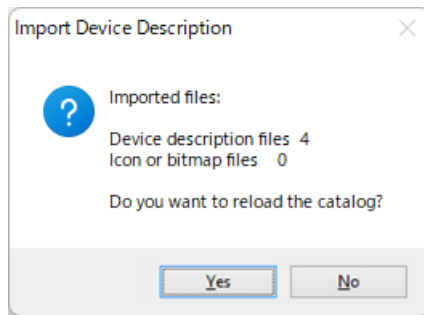

Adding a master icon

- (11) In the SYCON.net application software, go to the Device Catalog list on the right side of the-[NetDevice] window, and select -[PROFINET-IO]-[Master]-[CIFX RE/PNM V3].

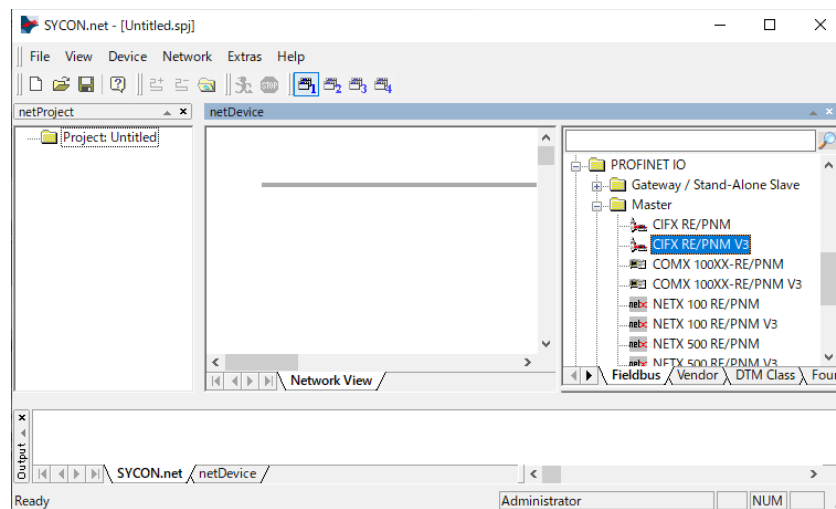

- (12) Drag & drop [CIFX RE/PNM V3] onto the bold line underneath [netDevice].

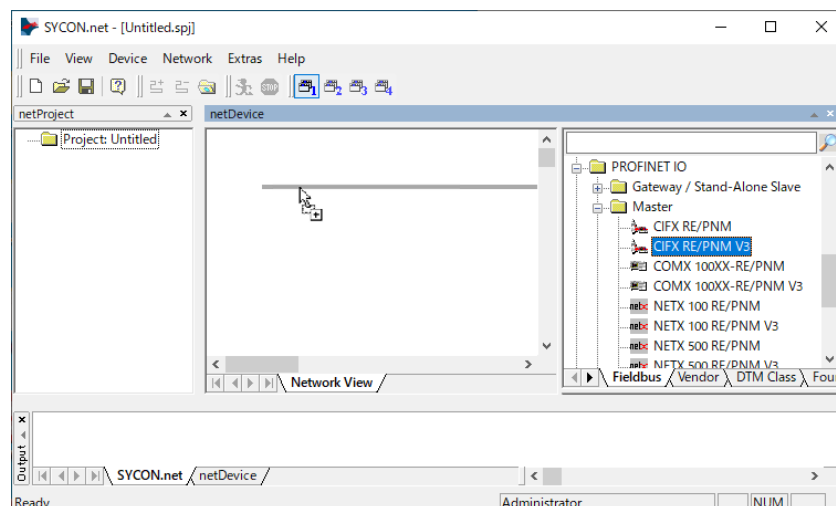

- (13) A "CIFX RE/PNM V3" icon indicating the PROFINET-IO board manufactured by Hilscher is connected.

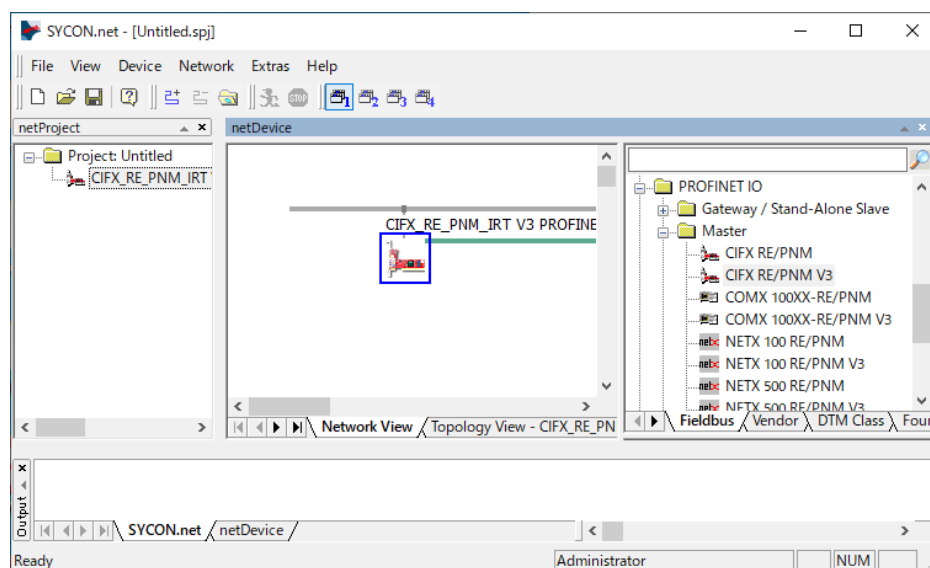

Adding a slave icon

- (14) In the SYCON.net application software, go to the Device Catalog list on the right side of the [NetDevice] window, and select -[PROFINET-IO]-[Slave]-and the name of the Slave device.

In the case of a PROFINET-IO slave module:

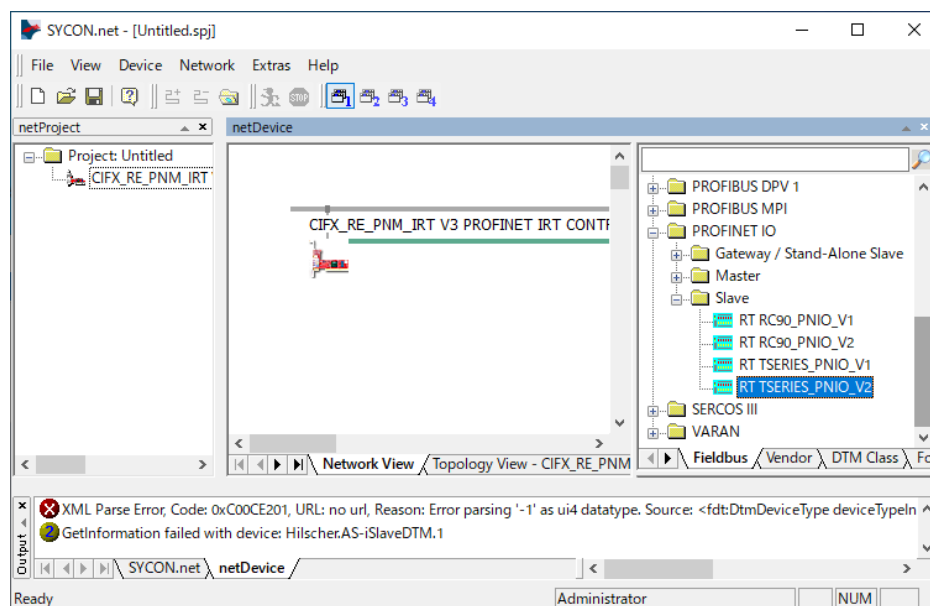

2. Installation

(15) Drag & drop the selected slave device on the bold line under [netDevice].

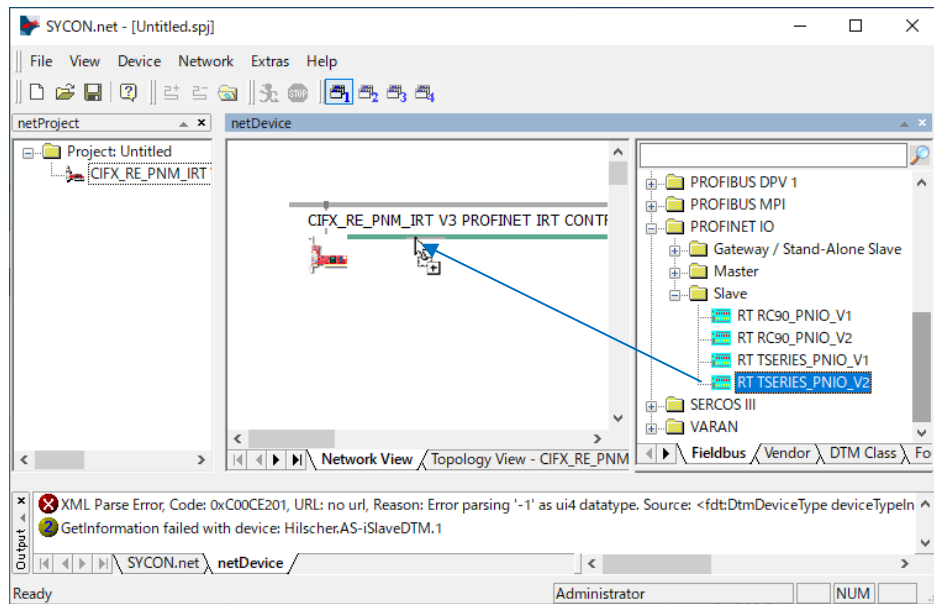

(16) The PROFINET-IO slave device is connected and its icon appears.

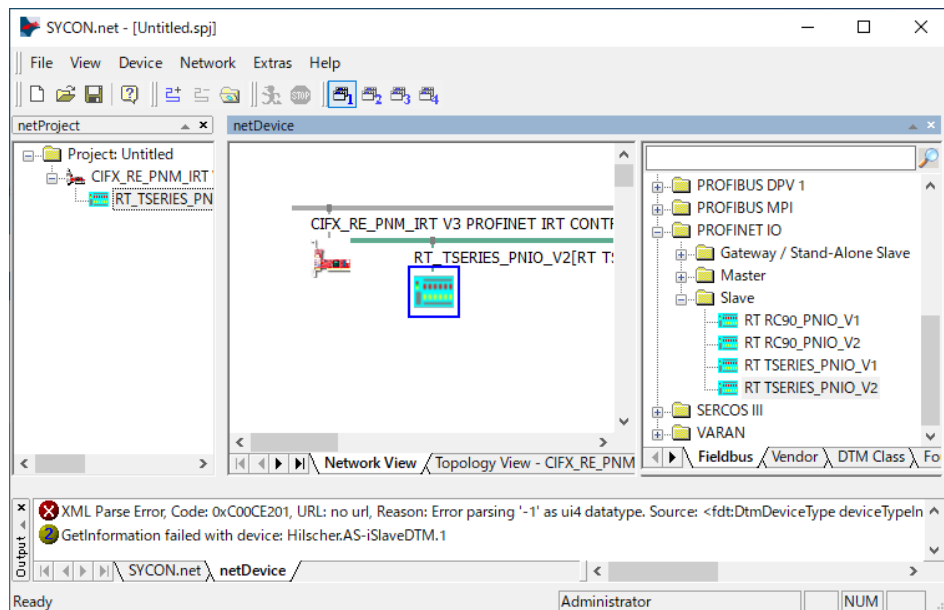

Settings on the master side

(17) Right-click [netDevice]-[CIFX_RE_PNM V3] and click [Configuration...].

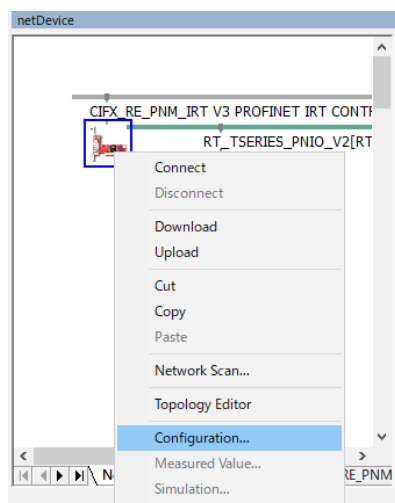

(18) The [Configuration] dialog box appears.

Select [Settings]-[Driver] tab.

Put a check in the [CIFX Device Driver] checkbox and click [Apply].

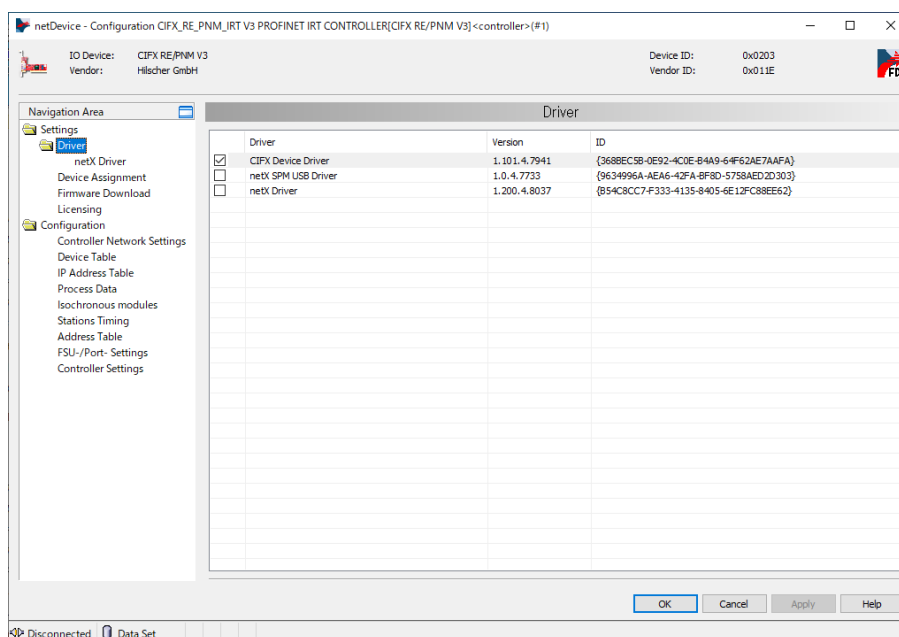

(19) Select [Settings]-[Device Assignment].

(20) Put a check in the [CIFX 50E-RE] checkbox.

Click [Apply].

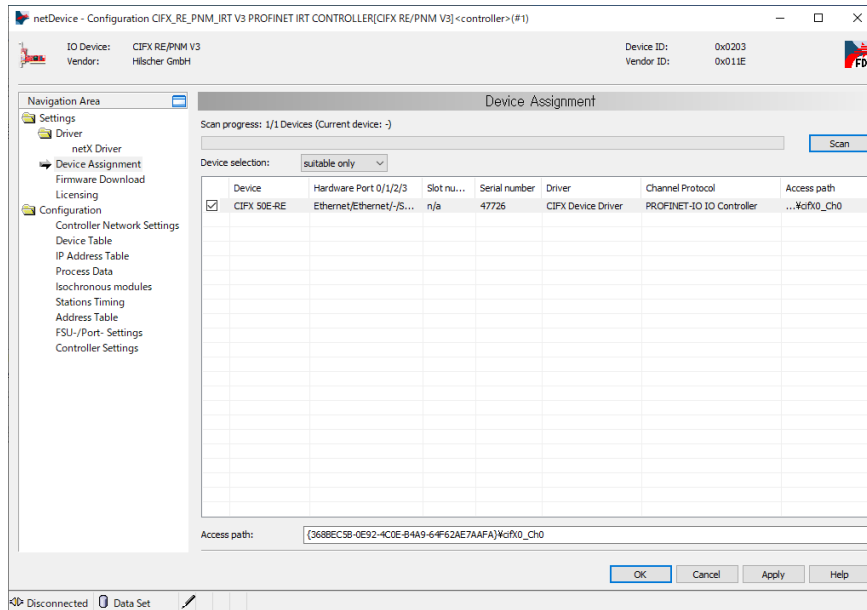

(21) Select the [Settings]-[Driver]-[Firmware Download] tab.

Click [Browse...].

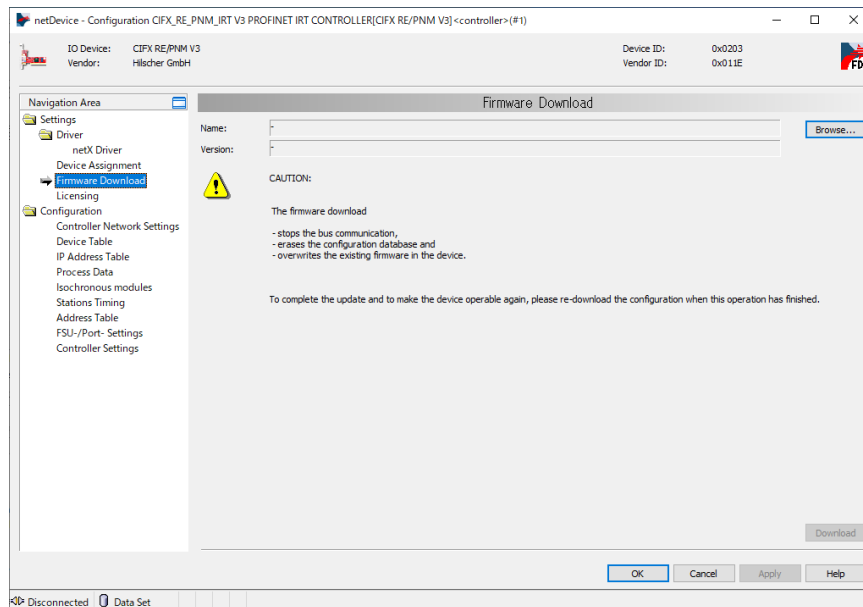

- (22) Open the [Firmware,_EDS,_Examples,_Webpages\Firmware_&_EDS\COMSOL-PNM V3.4.0.7\COMSOL-PNM V3.4.0.7\Firmware\cifX] folder on the Communication-Solutions DVD.
Select [C010C000.nxf].
Click [Open].

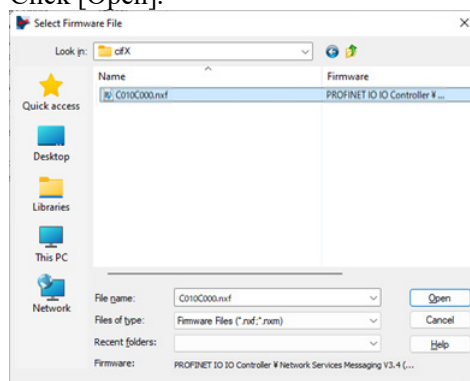

- (23) Confirm that [Name] is “PROFINET-IO IO Controller”.
Click [Download].

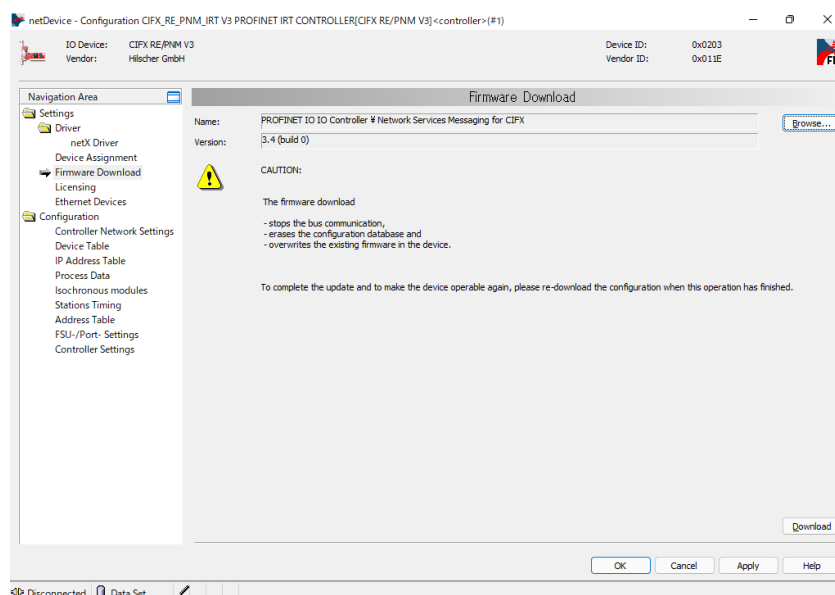

2. Installation

(24) Click [Yes].

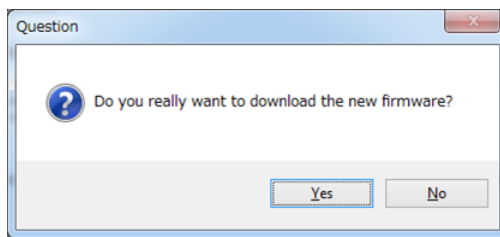

Start the installation of firmware.

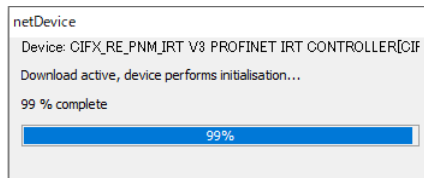

(25) Select the [Settings]-[Licensing] tab.

(26) Confirm that the license for [PROFINET IO RT Controller] shows “Existing: YES”.

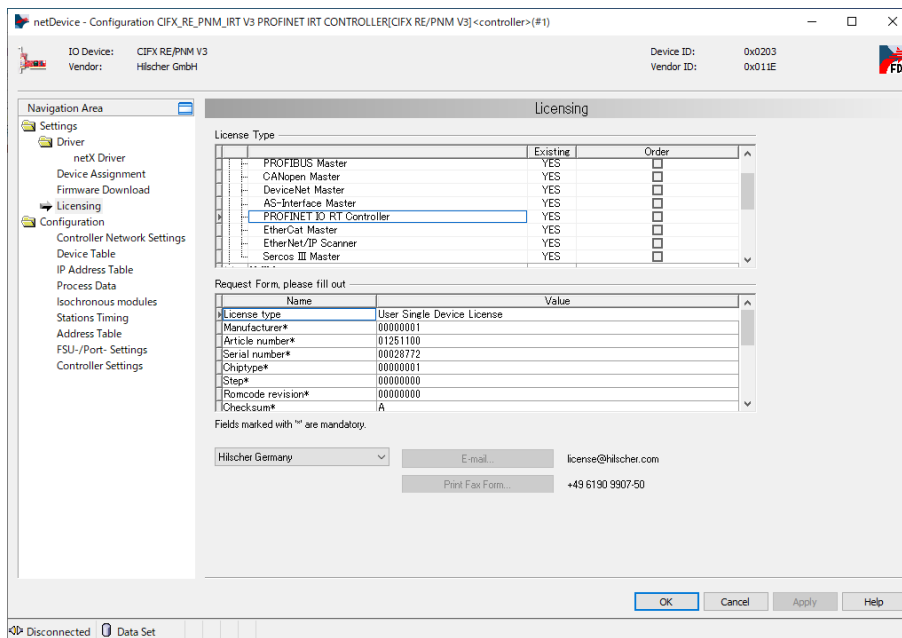

Configuring slave devices

Configure the slave devices (Station name, IP address, Network mask, Gateway address).

(27) Select [Settings]-[Ethernet Device] tab.

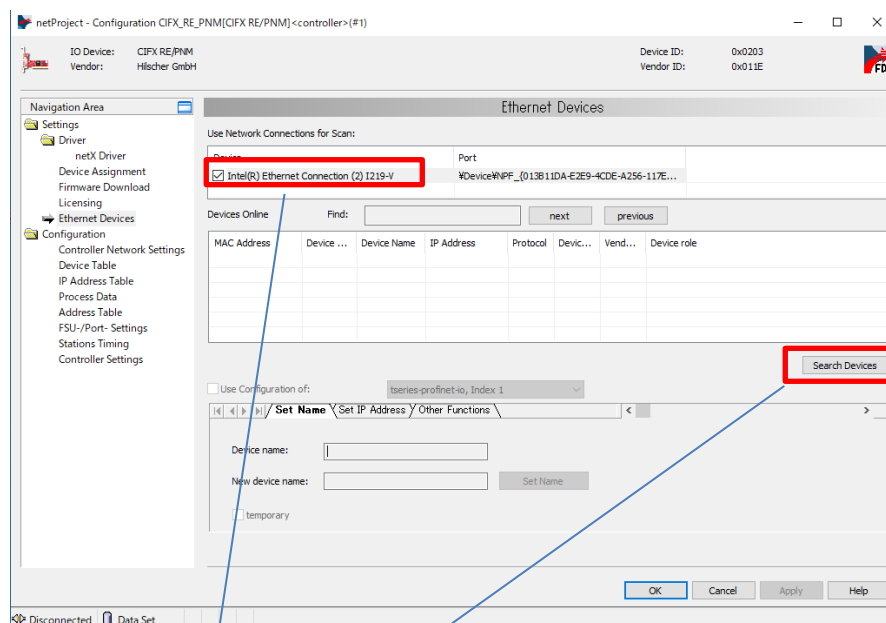

(28) Connect the **Ethernet port of the PC** to the PROFINET Slave device with an Ethernet cable.

(29) Click [Search Device] and search the PROFINET Slave devices on the network.

(30) The PROFINET Slave devices found on the network will be displayed on the screen.

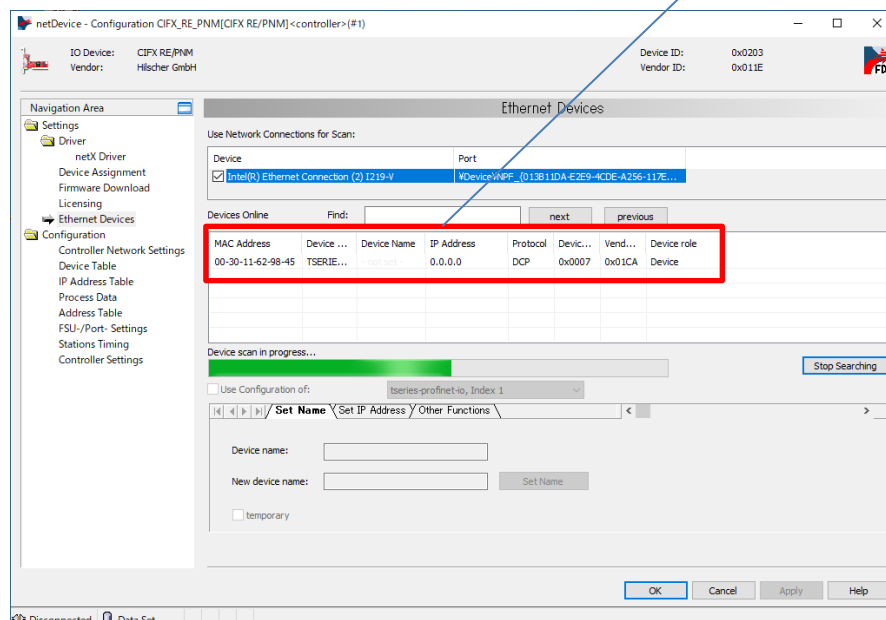

2. Installation

- (31) On the [Set Name] tab, set the station name of the PROFINET Slave device. Click [Set Name].

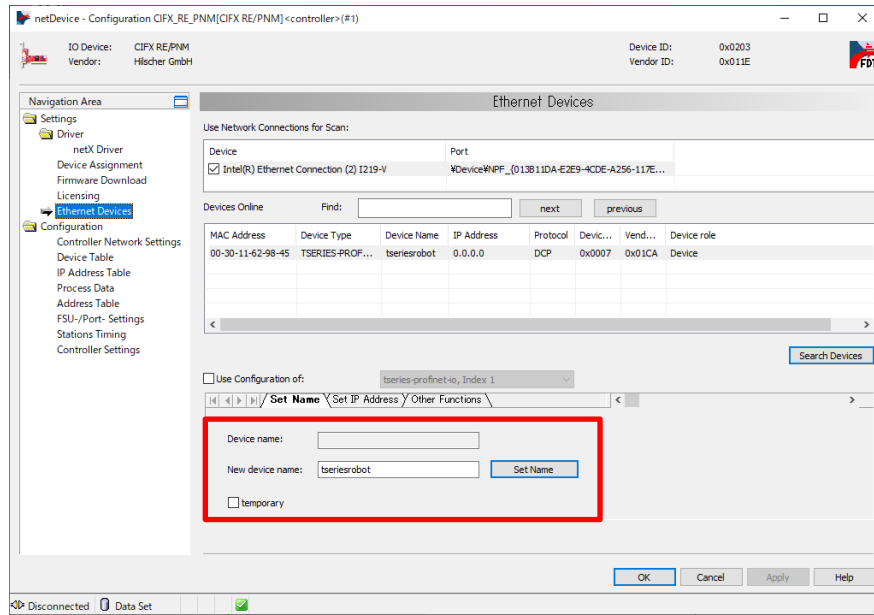

- (32) On the [Set IP Address] tab, set the IP address, Network mask, and gateway address of the PROFINET Slave device. Click [Set Address].

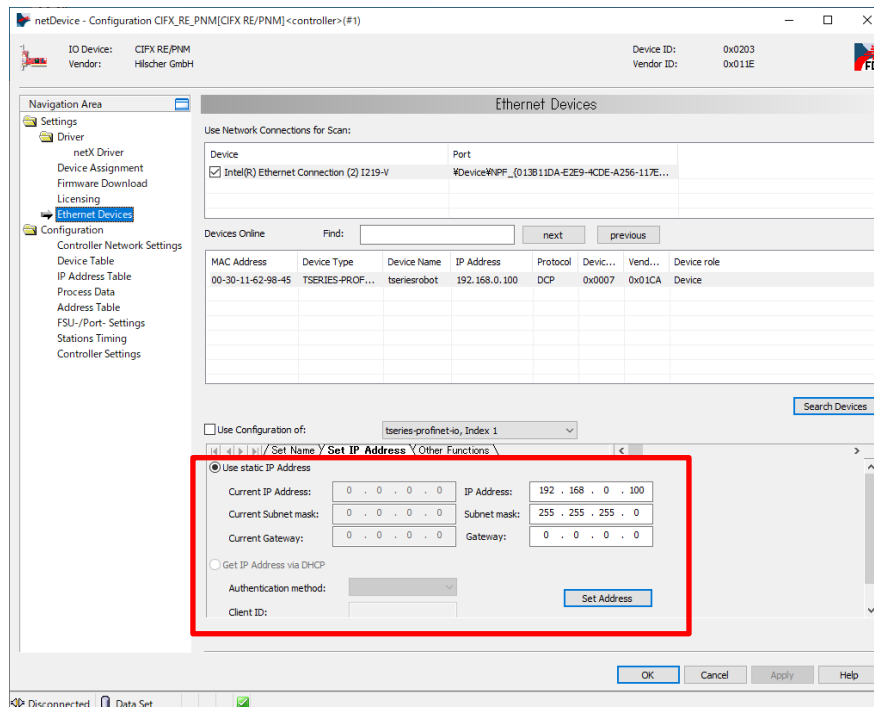

- (33) Connect the Ethernet port on the Hilscher PROFINET board to the PROFINET Slave device with an Ethernet cable.

(34) Select [Configuration]-[Controller Network Settings].

Configure [IP Settings] and click [Apply].

(Example:) IP Address: 192.168.0.1 (Fixed Addresses)

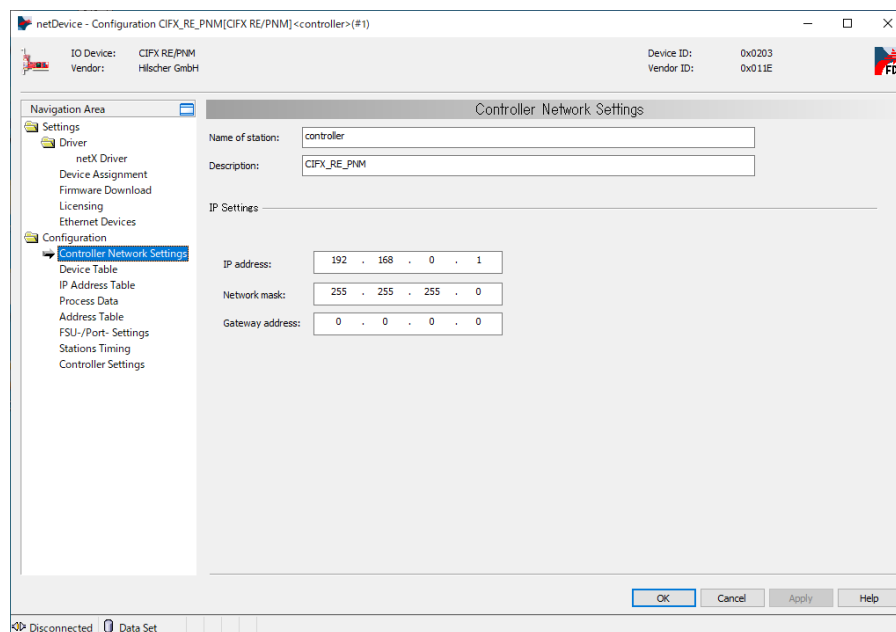

(35) Select [Configuration]-[Device Table].

Check the [Activate] checkbox for the slave device.

Enter the station name set in (31) in [Name of station] and click [Apply].

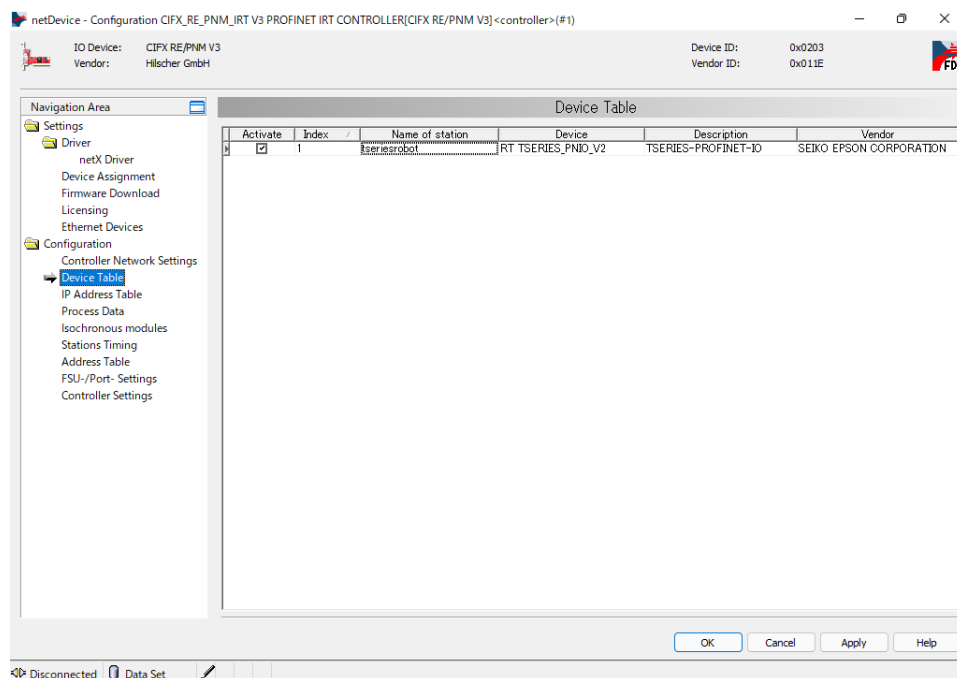

- (36) Select [Configuration]-[IP Address Table].
In [IP Address], enter the IP address set in (32) and click [OK].

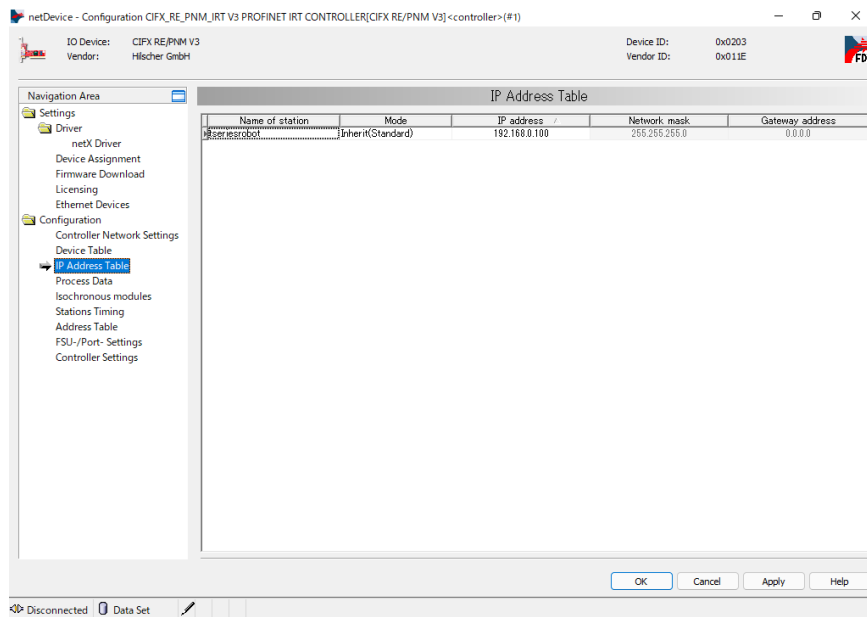

- (37) Close the [Configuration] dialog.

Configuring the slave side

- (38) Right-click the [netDevice] icon.
Click [Configuration...].

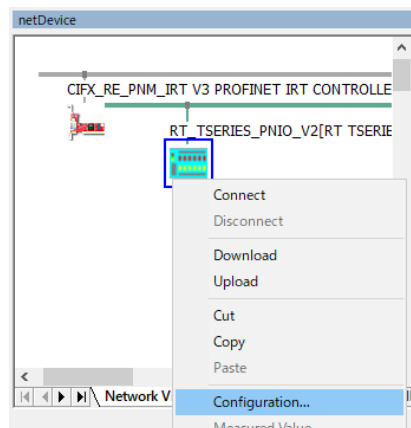

- (39) The [Configuration] dialog box appears.

(40) Select [Configuration]-[Modules].

Click [Add Module] and set the new module to Output 32 byte. (For a 32-byte setting)

Click [Add Module] again and set this new module to Input32 byte. (For a 32-byte setting)

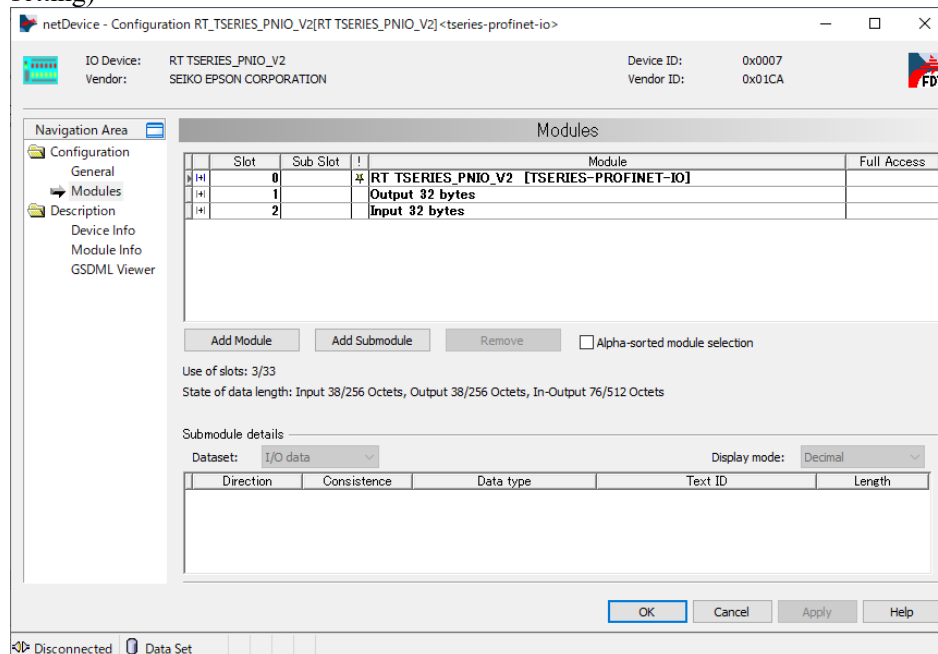

(41) Click [Apply].

(42) Close the [Configuration] dialog.

Downloading to the master board

(43) Right-click on the [netDevice]-[CIFX_RE_PNM V3] icon again, and click [Configuration...].

The [Configuration] dialog box appears.

(44) Click [Configuration]-[Address Table].

2. Installation

(45) Check the settings of [Address Table] and click [OK].

“Address Table”-Inputs Length: 32 (For 32-byte setting)

“Address Table”-Outputs Length: 32 (For 32-byte setting)

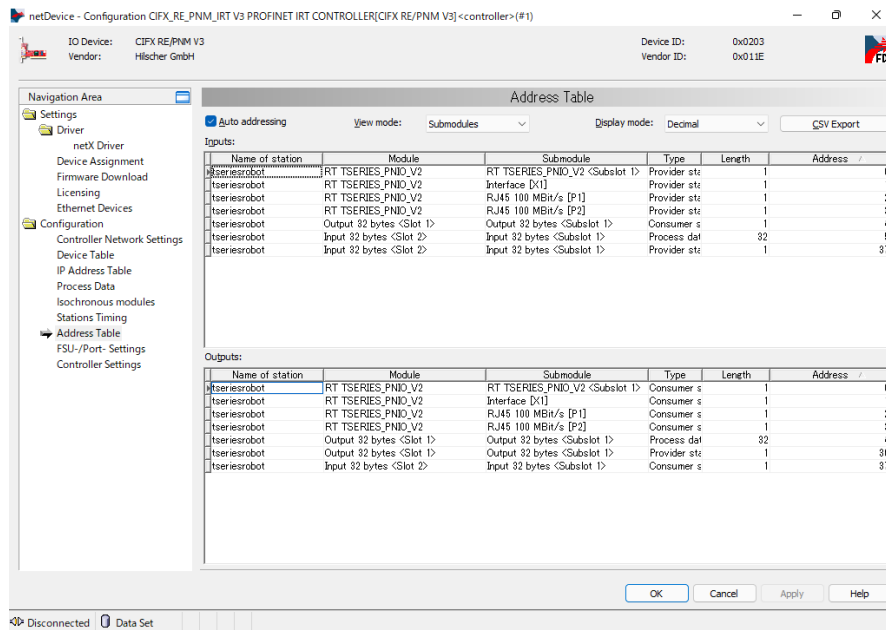

(46) Close [Configuration] dialog.

(47) Right-click [netDevice]-"CIFS_RE_PNM V3" icon and click [Download].

(48) Right-click [netDevice] slave icon and click [Download].

By performing the above step, “Setting on master side” and “Setting on slave side” are downloaded to the PROFINET board.

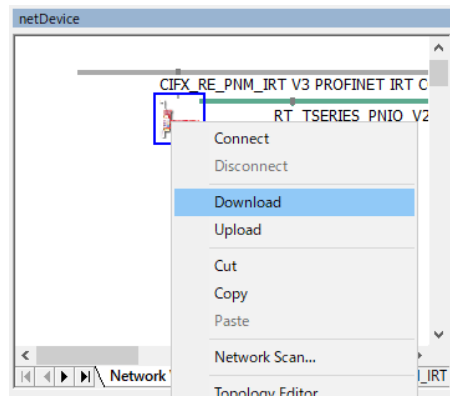

The settings are applied to PROFINET board manufactured by Hilscher.

Connection Diagnosis

- (49) Right-click the [netDevice]-"CIFX_RE_PNM V3" icon.
Select [Diagnosis...].

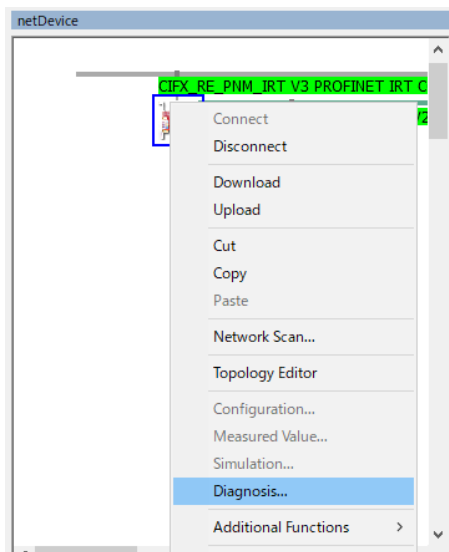

- (50) The [Diagnosis] dialog box appears.
Select [Diagnosis]-[General Diagnosis].

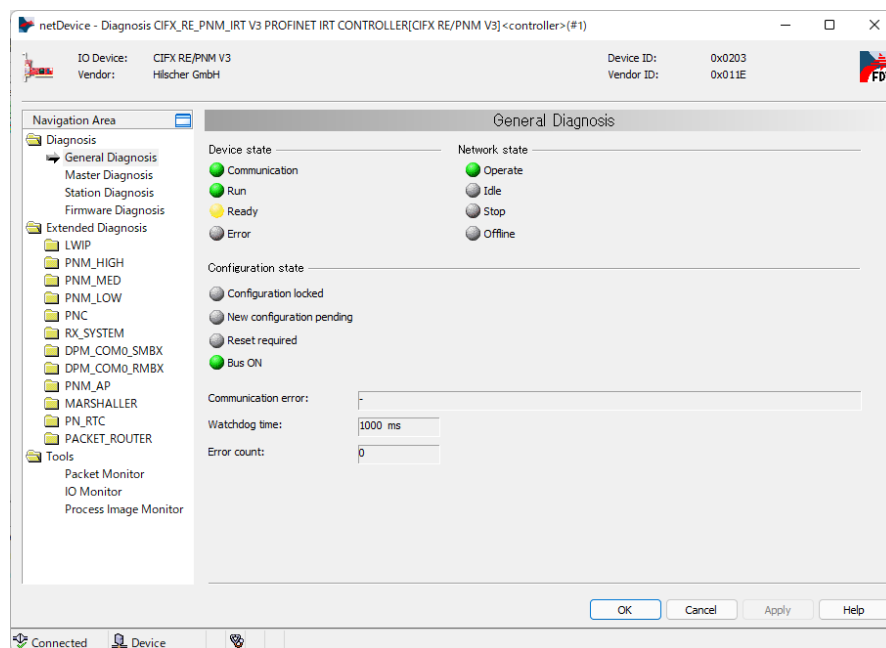

- (51) The state is normal when the Communication, Run, and Bus ON indicators are lit green and the Ready indicator is lit.

- (52) Select [Tools]-[IO Monitor] and perform the input/output test.

(53) Set IOPS in [Output data].

Communication can be started by entering "128" into the address of a module other than [Process data], which is displayed in the lower part of [Outputs:]-[Type] in (44). In this tutorial, we're going to set Output data: 0, 1, 2, 3, 36, 37 to "128".

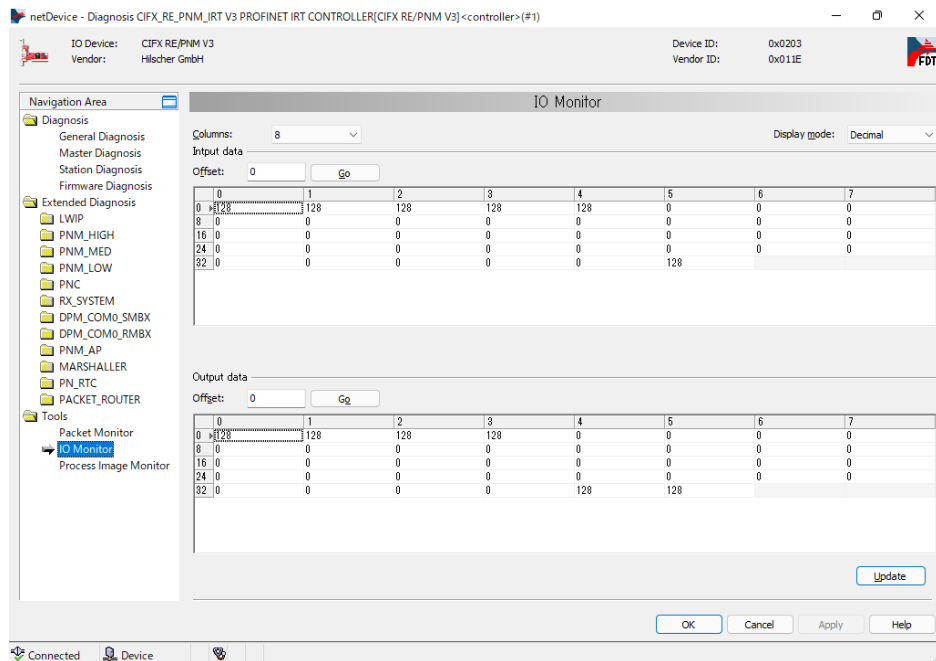

(54) Close the [Diagnosis] dialog.

(55) Click [File]-[Save] and save the settings changes to a file.

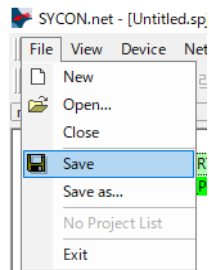

Exporting the Configuration File (.csv) for RC+

- (56) Right-click the [netDevice]-"CIFX_RE_PNM V3" icon.
Click [Additional Functions]-[Export]-[CSV...].

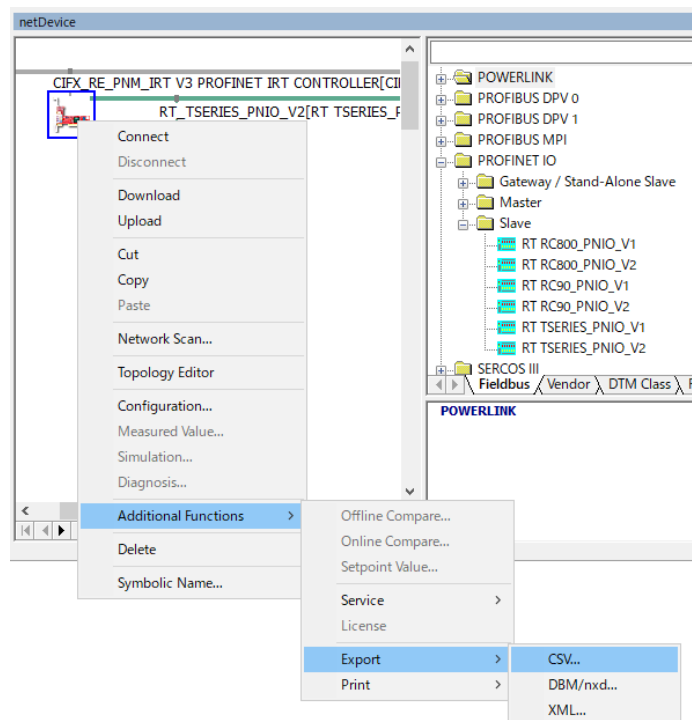

- (57) Save the CSV file to the file.

The exported CSV file will be used in the next section: *Epson RC+ 8.0 Configuration*.

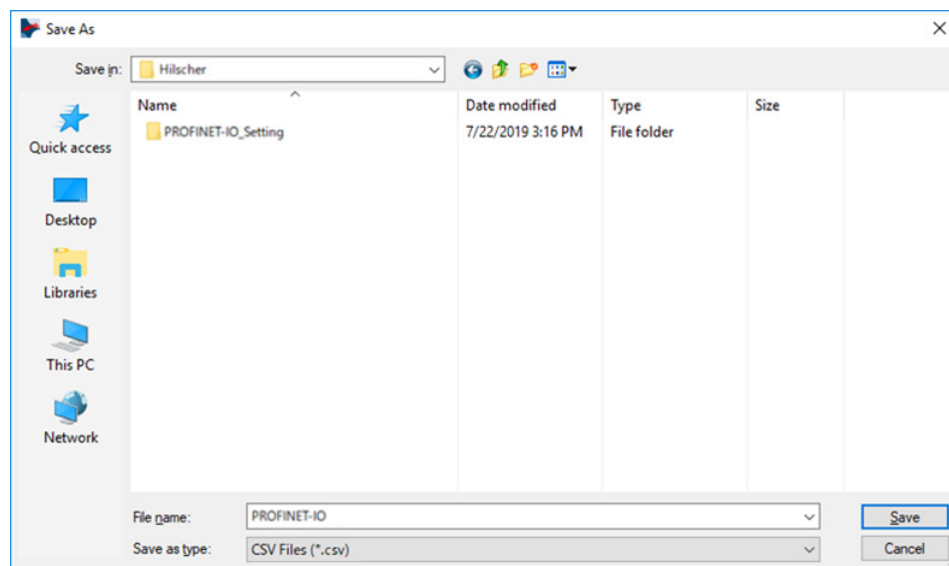

Now, the settings by SYCON.net are complete.
Close SYCON.net.



If there is a problem such as the fieldbus master board not being recognized by Windows, make sure that the combination is described in "Control System Configuration" in the preface of this manual and refer to the following section

4. Troubleshooting

4.4 How to Disable Fast Startup in Windows

Epson RC+ 8.0 Configuration

To use the fieldbus master board, the Robot system option setting and fieldbus master setting should be enabled in Epson RC+ 8.0.

- (1) Select [Setup]-[License Configuration] and open [License Configuration] dialog.
- (2) Refer to the *Epson RC+ User's Guide: Installing Controller Licenses* and enable the Fieldbus Master option.
- (3) Select [Setup]-[System Configuration] and display the [System Configuration] dialog box.
- (4) Select [Controller]-[Inputs/Outputs]-[Fieldbus Master]-[General].

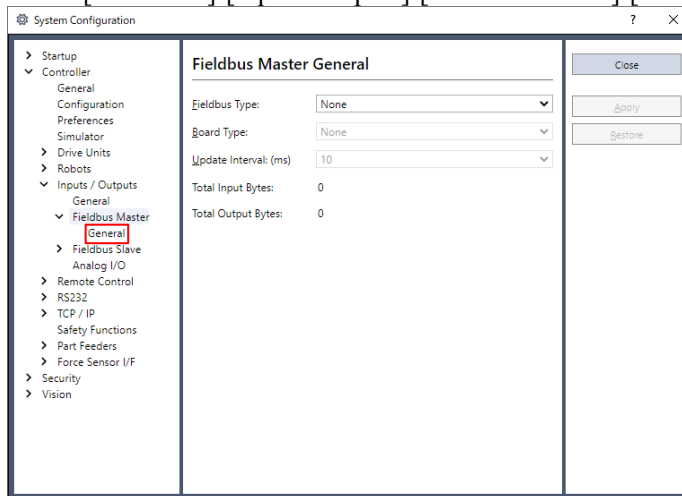

- (5) Set the following items:
 - [Fieldbus Type:] PROFINET
 - [Board Type:] Hilscher
 - [Update Interval:] Update cycle for the PROFINET master I/O

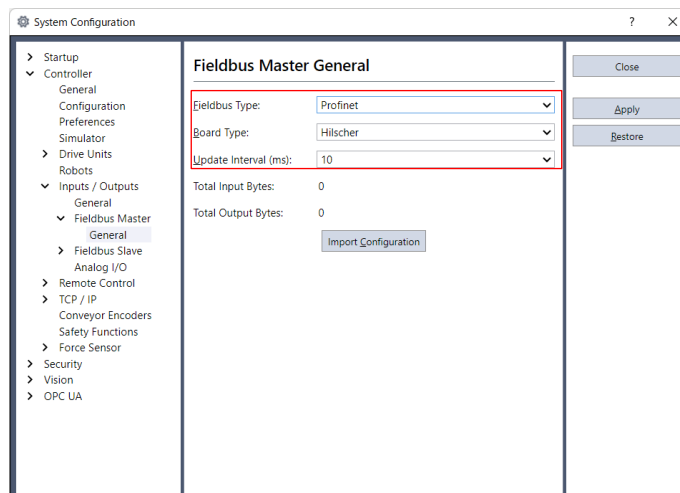

Click [Import Configuration].

- (6) Select the configuration file (.csv) for RC+.
Click [Open].

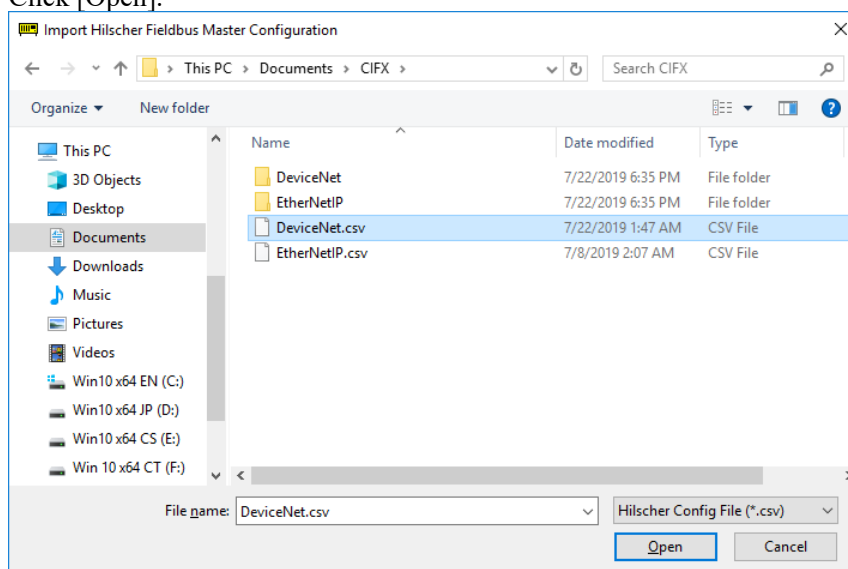

- (7) Confirm that the configuration file (.csv) for RC+ is imported and click [OK].

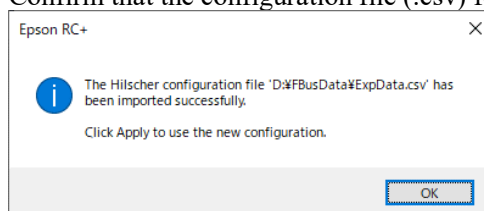

- (8) Click [Apply]. Confirm that the following items are displayed.

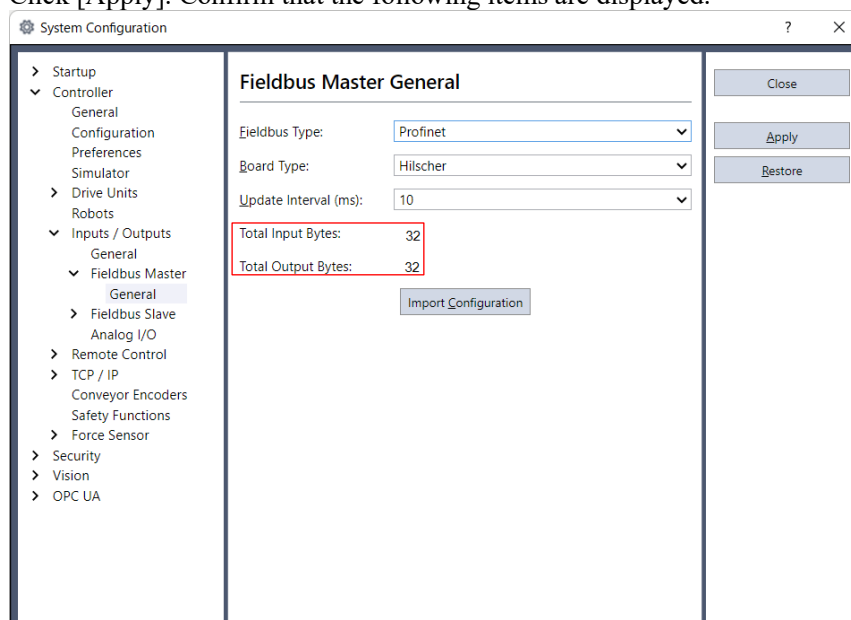

Total Input Bytes : Number of inputs the master controls (Bytes)

Total Output Bytes : Number of outputs the master controls (Bytes)

2. Installation

- (9) Click [Close].
The following dialog box appears and the Robot Controller automatically starts rebooting.



2.5.2 Installing PROFINET Slave Board

Appearance

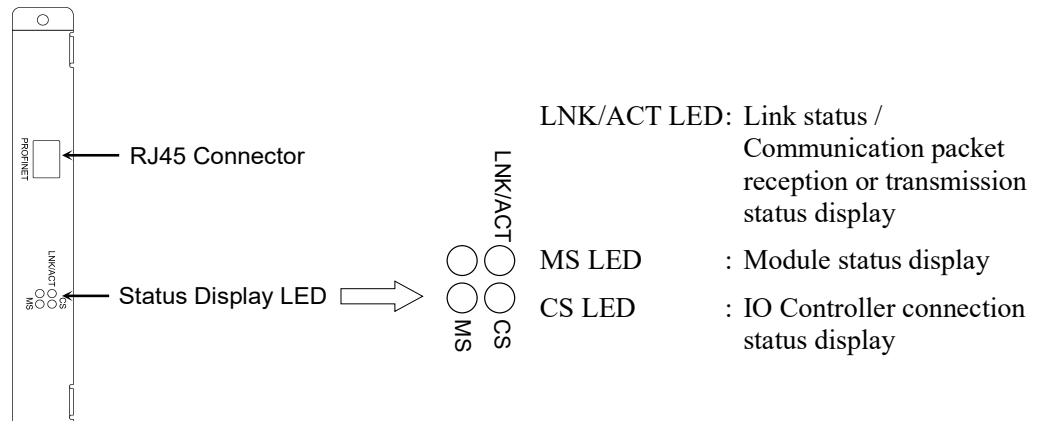

The Fieldbus slave board is configured as follows at shipment.

Board Appearance

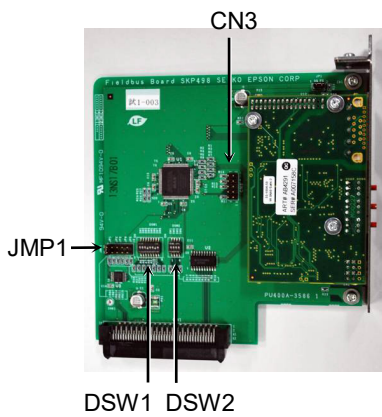

Configuration

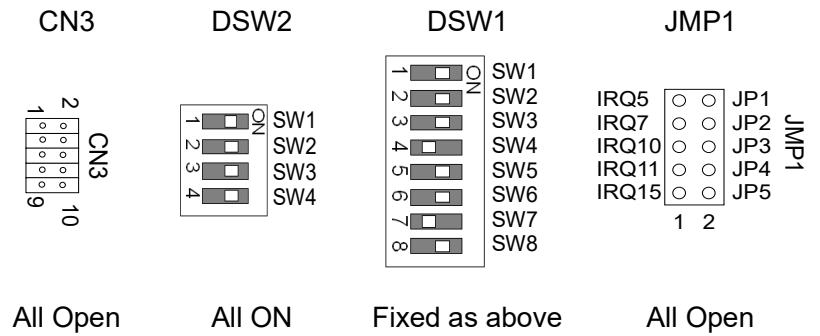

Specifications

Item	Specification
Name	PROFINET board
Connection Method	RT (Real-Time)
Protocol	PROFINET IO
Device type	IO device
Baud Rates (bps)	100 M bps, full duplex
Maximum segment length	100 m
Cable	RJ45 with connector 100BASE-TX (Cat5)
Cycle time	2 msec
Interface	RJ45 port × 1
Input Data Size	Max. 2048 bits (256 bytes)
Output Data Size	Max. 2048 bits (256 bytes)

LED Description

LED state represents the states of the fieldbus board.

LED state		MS	CS	LNK/ACT
OFF		Power OFF or Device is being initialized	Offline	No link or Power OFF
GRN	ON	Normal operation	Offline IO Controller is in RUN	Linking
	Blinking	-	-	Receiving/transmitting communication packet
	Blinking once	Evaluating	Offline / IO Controller is in STOP	-
RED	Blinking	Blinking once	-	-
		Blinking 3 times	-	-
		Blinking 4 times	-	-

Setting Configure Switch

The PROFINET board requires no configurations.

All the PROFINET communication configurations are set by the development software (Epson RC+ 8.0).

Wiring

PROFINET connector is RJ45 connector. Use 100BASE-TX (STP type) cable.



CAUTION

- Be sure to use cables and connectors complying with the industrial standards or noise resistant Ethernet cable (STP cable). If you use an office use product or UTP cable, it may cause communication errors and may not offer the proper performance.

Installing a Board



WARNING

- Make sure that the power is turned OFF before installing/removing any boards or connecting/disconnecting any cables. Working with the power ON is extremely hazardous and may result in electrical shock and/or malfunction of equipment.

Install the board to the dedicated slot on the Robot Controller.

Reference manuals:

RC700 Series Maintenance MANUAL 7.1 Option Board

RC90 Series Maintenance MANUAL 7.1 Option Board

When using RC700-D and RC700-E, please contact the supplier of your region.

Confirmation with Epson RC+ 8.0

When PROFINET slave board is installed in the Controller, it is recognized automatically. Confirm that Epson RC+ 8.0 has recognized the board in the following procedure.

1. Select [Setup]-[System Configuration] and display the [System Configuration] dialog box.
2. Select [Controller]-[Inputs / Outputs].

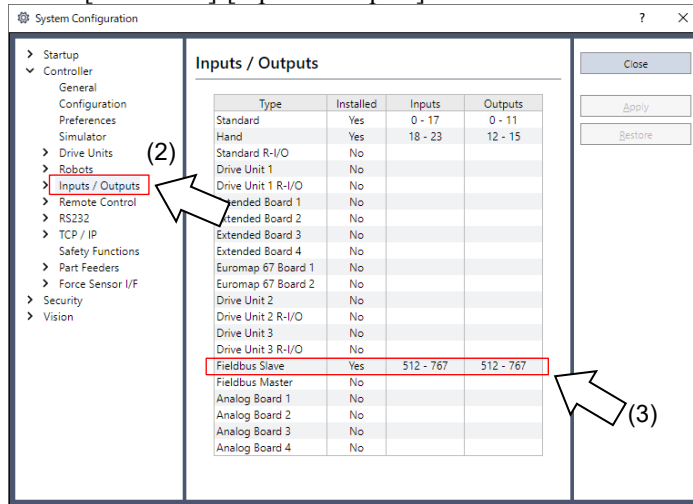

3. Confirm that following items are displayed in “Fieldbus Slave”.
 - Installed : Yes
 - Inputs : 512-767 (default setting)
 - Outputs : 512-767 (default setting)
4. Click [Fieldbus Slave]-[General].

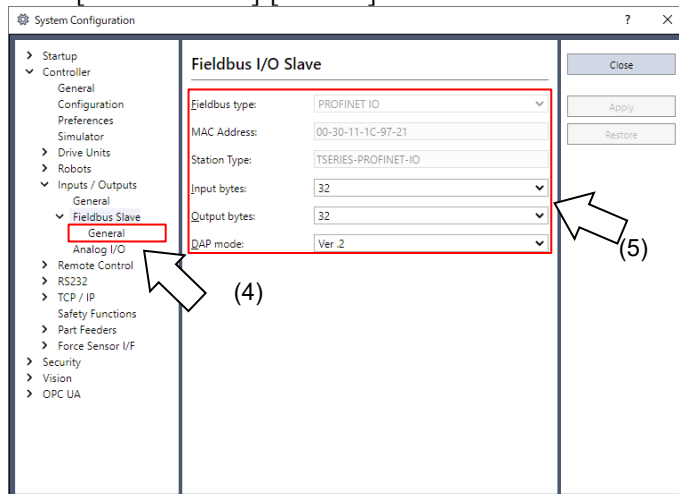

5. Confirm that following items are displayed.
 - Fieldbus Type : PROFINET IO
 - Input Byte : 32 (default setting)
 - Output Byte : 32 (default setting)
6. Click [Close].

Editing of Input / Output Size and DAP Mode

You can change the input/output size of the PROFINET slave board if necessary.

1. Select [Setup]-[System Configuration] and display the [System Configuration] dialog box.
2. Select [Controller]-[Inputs / Outputs]-[Fieldbus Slave]-[General].

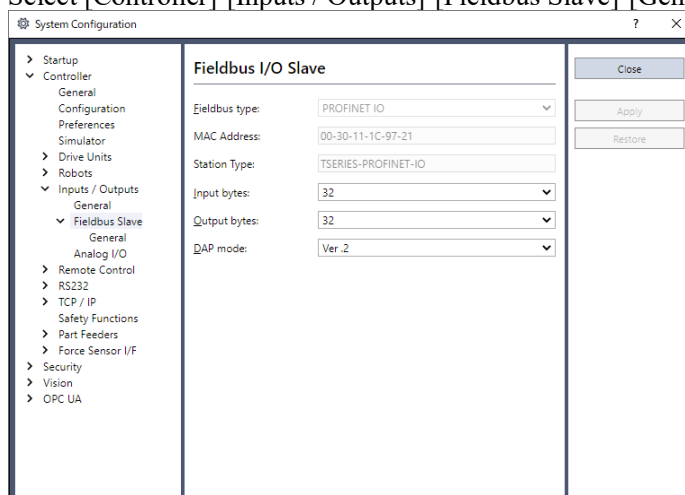

3. Change the settings of [Input Byte] and [Output Byte].
In this example, both of them are changed to 20 Bytes.

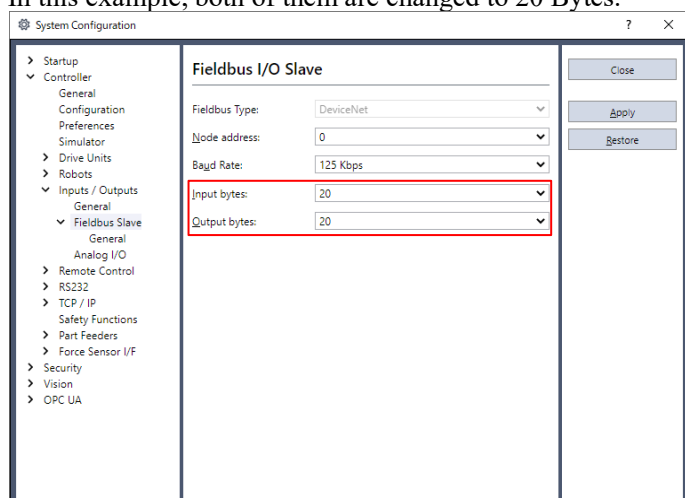

4. Change the setting of [DAP mode] if necessary.
5. Set [DAP mode] according to the PROFINET IO Controller that you want to use. Usually, select DAP Ver.2. DAP Ver.1 is available for the obsolete PROFINET IO Controller.



The PROFINET option does not have the alert function that is an optional function in DAP Ver.2.

6. Click [Apply].

- Click [Close].

The following dialog box appears and the Robot Controller automatically starts rebooting.



- Select [Setup]-[System Configuration] and display the [System Configuration] dialog box.
- Select [Controller]-[Inputs / Outputs].

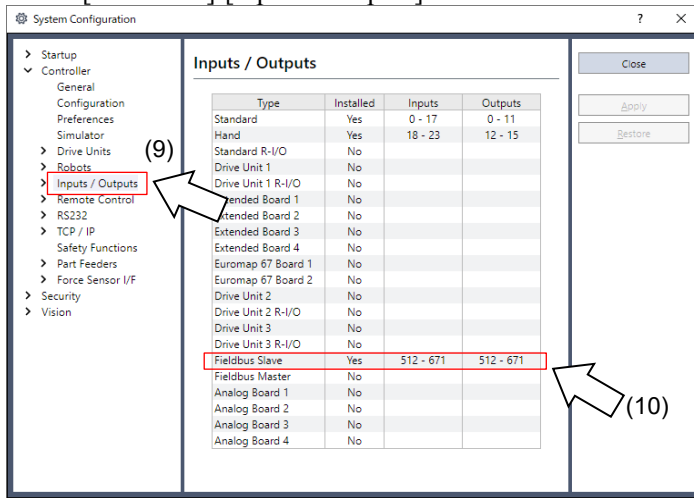

- Confirm that the following items are displayed in “Fieldbus slave”.

Inputs : 512 – (512 + Changed number of input (Bits))
 Outputs : 512 – (512 + Changed number of output (Bits))

In this example, Input byte is 20 bytes (160 bits) and 512-671 is displayed in Inputs.
 Also, Output byte is 20 bytes (160 bits) and 512-671 is displayed in Outputs.

- Click [Close].



When setting this option to the PROFINET IO Controller (Master), configure as below.

The Robot Controller includes 16 pseudo I/O slots. In these slots, add 1 to 32 bytes input modules, output modules.

Make sure to add the output modules first, and then, add the input modules.

Example Input: 40 bytes / Output: 48bytes (set in the RC+ window)

- Slot 1 : 32 bytes output module
- Slot 2 : 16 bytes output module
(Set 48 bytes in total for the Output.)
- Slot 3 :32 bytes input module
- Slot 4 : 8 bytes input module
(Set 40 bytes in total for the Input.)

Electronic Information File (GSDML file)

A GSDML file is provided for the PROFINET slave board network configuration. The file is located in the following folder where Epson RC+ 8.0 is installed.

C:\EpsonRC80\Fieldbus\PROFINET

Compatible list of GSDML file

Controller	File name
RC700 series	GSDML-V2.3-EPSON-RC700PNIO-20180125.xml
RC90 series	GSDML-V2.3-EPSON-RC90PNIO-20180125.xml

2.5.3 Installing PROFINET Slave Module

 WARNING	<ul style="list-style-type: none"> Make sure that the power is turned OFF before installing/removing any modules or connecting/disconnecting any cables. Working with the power ON is extremely hazardous and may result in electrical shock and/or malfunction of equipment.
--	--

 CAUTION	<ul style="list-style-type: none"> Pay attention to the followings in order to prevent the the connecter from coming off. <ol style="list-style-type: none"> Use the connectors attached to the module. Insert the connectors all the way seated. Fix the cables at proper positions in order not to put a load on the connectors.
--	---

 CAUTION	<ul style="list-style-type: none"> Use the Controller firmware and the PROFINET module in the following combinations. It does not guarantee the correct motions if you use any combination other than those listed below. <table border="1" style="margin-left: auto; margin-right: auto;"> <thead> <tr> <th>Controller</th> <th>Controller Firmware Version</th> <th>PROFINET Module Version</th> </tr> </thead> <tbody> <tr> <td rowspan="3" style="text-align: center;">T/VT Series</td> <td style="text-align: center;">Before 7.5.54.14</td> <td style="text-align: center;">V.1.33</td> </tr> <tr> <td rowspan="2" style="text-align: center;">7.5.54.14 or later</td> <td style="text-align: center;">V.1.33</td> </tr> <tr> <td style="text-align: center;">V.2.05</td> </tr> <tr> <td style="text-align: center;">RC800 Series</td> <td style="text-align: center;">In all versions</td> <td style="text-align: center;">V.2.08</td> </tr> </tbody> </table>	Controller	Controller Firmware Version	PROFINET Module Version	T/VT Series	Before 7.5.54.14	V.1.33	7.5.54.14 or later	V.1.33	V.2.05	RC800 Series	In all versions	V.2.08
Controller	Controller Firmware Version	PROFINET Module Version											
T/VT Series	Before 7.5.54.14	V.1.33											
	7.5.54.14 or later	V.1.33											
		V.2.05											
RC800 Series	In all versions	V.2.08											

NOTE  Refer to *Epson RC+ 8.0 User's Guide "[System Configuration] Command (Setup Menu)" [Setup]-[System Configuration]-[Controller]-[Preferences]* to check the firmware version.

NOTE  The module version of PROFINET is indicated on the label on the back of the module.



Appearance

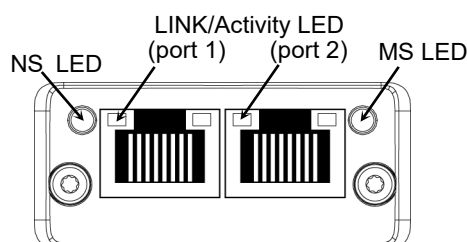

Specifications

Item	Specification	
Name	PROFINET Slave Module	
Connection Method	RT (Real-Time)	
Protocol	PROFINET IO	
Device type	IO device	
Baud Rates (bps)	100 M bps, full duplex	
Maximum segment length	100 m	
Cable	RJ45 with connector 100BASE-TX (Cat5)	
Cycle time	2 ms	
Interface	RJ45 port × 1	
Max. Input Data Size	RC800 series	T/VT series
	4096 bits (512 bytes)	2048 bits (256 bytes)
Max. Output Data Size	RC800 series	T/VT series
	4096 bits (512 bytes)	2048 bits (256 bytes)

LED Description

LED state represents the states of the fieldbus module.

NS: Network Status LED

LED State	Description	Comments
OFF	Offline	No power No connection with IO Controller
Green	Online (RUN)	Connection with IO Controller established IO Controller in RUN state
Green, 1 flash	Online (STOP)	Connection with IO Controller established IO Controller in STOP state or IO data bad IRT synchronization not finished
Green, blinking	Blink	Used by engineering tools to identify the node on the network
Red	Fatal event	Major internal error (this indication is combined with a red module status LED)
Red, 1 flash	Station Name error	Station Name not set
Red, 2 flashes	IP address error	IP address not set
Red, 3 flashes	Configuration error	Expected Identification differs from Real Identification

MS: Module Status LED

LED State	Description	Comments
OFF	Not Initialized	No power OR Module in SETUP or NW_INIT state.
Green	Normal Operation	Module has shifted from the NW_INIT state.
Green, 1 flash	Diagnostic Event(s)	Diagnostic event(s) present
Red	Exception error	Device in state EXCEPTION.
	Fatal event	Major internal error (this indication is combined with a red net- work status LED)
Alternating Red/ Green	Firmware update	Do NOT power off the module. Turning the module off during this phase could cause permanent damage.

LINK/Activity LED

LED State	Description	Comments
OFF	No Link	No link, no communication present
Green	Link	Ethernet link established, no communication present
Green, flickering	Activity	Ethernet link established, communication present

Setting Configure Switch

The PROFINET module requires no configurations.

All the PROFINET communication configurations are set by the development software (Epson RC+ 8.0).

Wiring

PROFINET connector is RJ45 connector. Use 100BASE-TX (STP type) cable.



CAUTION

- Be sure to use cables and connectors complying with the industrial standards or noise resistant Ethernet cable (STP cable). If you use an office use product or UTP cable, it may cause communication errors and may not offer the proper performance.

Installing Module



WARNING

- Make sure that the power is turned OFF before installing/removing any modules or connecting/disconnecting any cables. Working with the power ON is extremely hazardous and may result in electrical shock and/or malfunction of equipment.

Install the module to the Controller's dedicated slot.

Reference manuals:

T series MAINTENANCE MANUAL 14.6 Fieldbus I/O

T-B series MAINTENANCE MANUAL 14.5 Fieldbus I/O

VT series MAINTENANCE MANUAL 18.7 Fieldbus I/O

RC800 series Service Manual 4.1.3 Fieldbus I/O Module

Confirmation with Epson RC+ 8.0

When PROFINET slave module is installed in the Controller, it is recognized automatically.

Confirm that Epson RC+ 8.0 has recognized the module in the following procedure.

1. Select [Setup]-[System Configuration] and display the [System Configuration] dialog box.
2. Select [Controller]-[Inputs / Outputs].

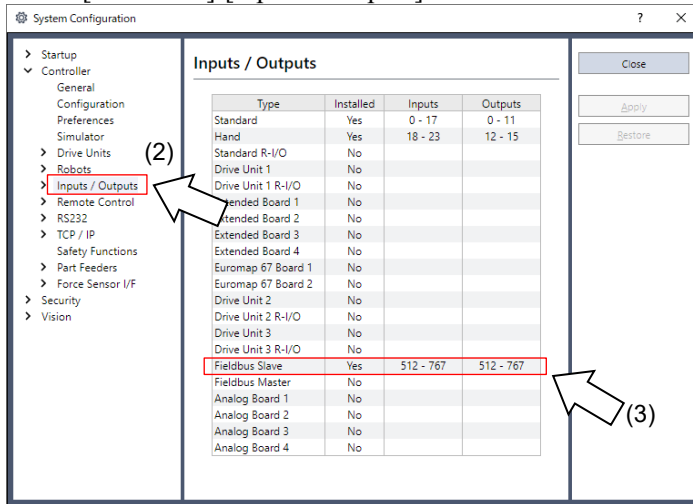

3. Confirm that following items are displayed in “Fieldbus Slave”.
 Installed : Yes
 Inputs : 512-767 (default setting)
 Outputs : 512-767 (default setting)
4. Click [Fieldbus Slave].

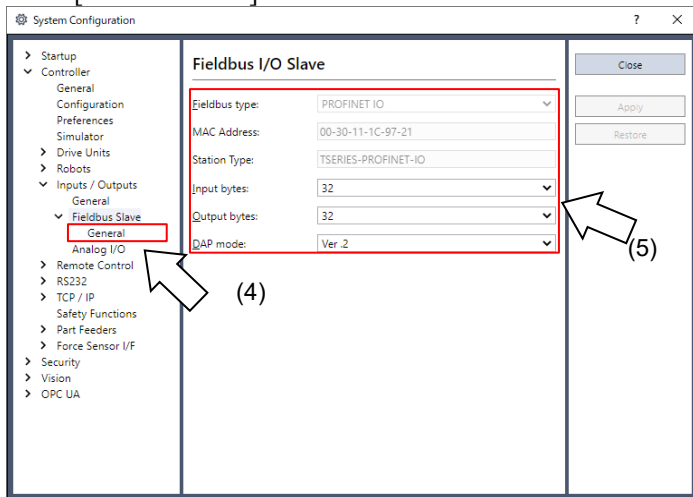

5. Confirm that following items are displayed.
 Fieldbus Type : PROFINET IO
 Input Byte : 32 (default setting)
 Output Byte : 32 (default setting)
6. Click [Close].

Editing of Input / Output Size and DAP Mode

You can change the input/output size of the PROFINET slave module if necessary.

1. Select [Setup]-[System Configuration] and display the [System Configuration] dialog box.
2. Select [Controller]-[Inputs / Outputs]-[Fieldbus Slave].

The screenshot shows the 'System Configuration' dialog box with the 'Fieldbus I/O Slave' tab selected. The left sidebar shows a tree view with 'Inputs / Outputs' > 'Fieldbus Slave' selected. The main area contains the following settings:

Fieldbus type:	PROFINET IO
MAC Address:	00-30-11-1C-97-21
Station Type:	TSERIES-PROFINET-IO
Input bytes:	32
Output bytes:	32
DAP mode:	Ver.2

Buttons on the right include 'Close', 'Apply', and 'Restore'.

3. Change the settings of [Input Byte] and [Output Byte].

This screenshot is identical to the previous one, but the 'Input bytes' and 'Output bytes' fields are highlighted with a red rectangular box, indicating they have been changed to 20.

Fieldbus type:	PROFINET IO
MAC Address:	00-30-11-1C-97-21
Station Type:	TSERIES-PROFINET-IO
Input bytes:	20
Output bytes:	20
DAP mode:	Ver.2

4. Change the setting of [DAP mode] if necessary.
5. Set [DAP mode] according to the PROFINET IO Controller that you want to use. Usually, select DAP Ver.2. DAP Ver.1 is available for the obsolete PROFINET IO Controller.



The PROFINET option does not have the alert function that is an optional function in DAP Ver.2.

6. Click [Apply].

- Click [Close].

The following dialog box appears and the Controller automatically starts rebooting.



- Select [Setup]-[System Configuration] and display the [System Configuration] dialog box.
- Select [Controller]-[Inputs / Outputs].

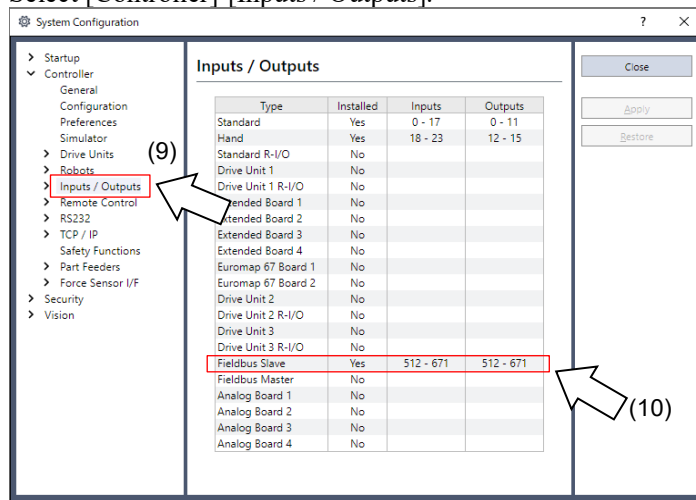

- Confirm that the following items are displayed in “Fieldbus slave”.

Inputs : 512 – (512 + Changed number of input (Bits))
 Outputs : 512 – (512 + Changed number of output (Bits))

In this example, Input byte is 20 bytes (160 bits) and 512-671 is displayed in Inputs. Also, Output byte is 20 bytes (160 bits) and 512-671 is displayed in Outputs.

- Click [Close].



When setting this option to the PROFINET IO Controller (Master), configure as below.

The Robot Controller includes 16 pseudo I/O slots. In these slots, add 1 to 32 bytes input modules, output modules.

Make sure to add the output modules first, and then, add the input modules.

Example Input: 40 bytes / Output: 48bytes (set in the RC+ window)

Slot 1 : 32 bytes output module
 Slot 2 : 16 bytes output module
 (Set 48 bytes in total for the Output.)
 Slot 3 :32 bytes input module
 Slot 4 : 8 bytes input module
 (Set 40 bytes in total for the Input.)

Electronic Information File (GSDML file)

A GSDML file is provided for the PROFINET slave module network configuration. The file is located in the following folder where Epson RC+ 8.0 is installed.

C:\EpsonRC80\Fieldbus\PROFINET

Use in the following combinations.

Compatible list of GSDML file

Controller	Controller Firmware Version	PROFINET Module Version	File Name
T/VT Series	Before 7.5.54.14	V.1.33	GSDML-V2.32-EPSON-TSERIESPNIO-20180125.xml
	7.5.54.14 or later	V.1.33	GSDML-V2.32-EPSON-TSERIESPNIO-20180125.xml
		V.2.05	GSDML-V2.43-EPSON-TSERIESPNIO-20230914.xml
RC800 Series	In all Versions	V.2.08	GSDML-V2.44-EPSON-RC800PNIO-20240410.xml

2.6 EtherCAT

2.6.1 Installing EtherCAT Slave Board

Appearance

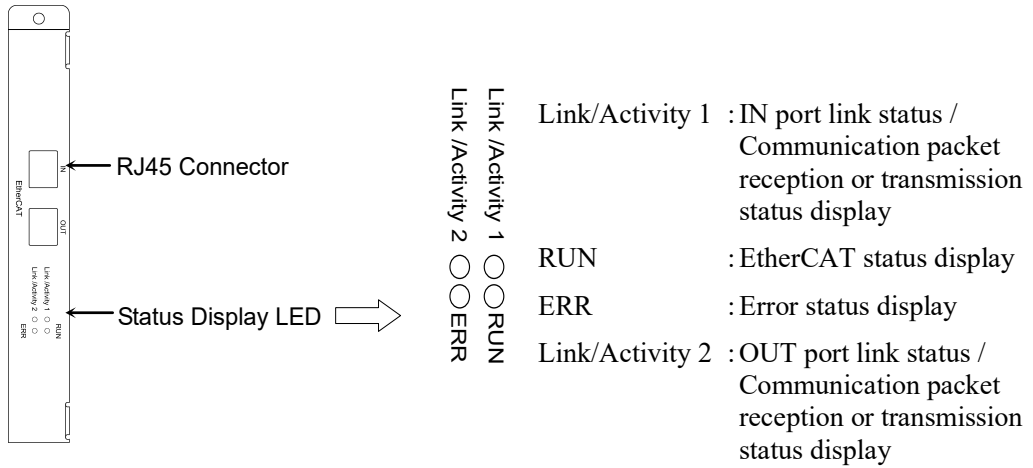

The Fieldbus slave board is configured as follows at shipment

Board Appearance

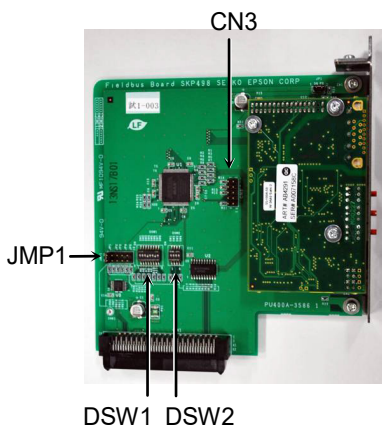

Configuration

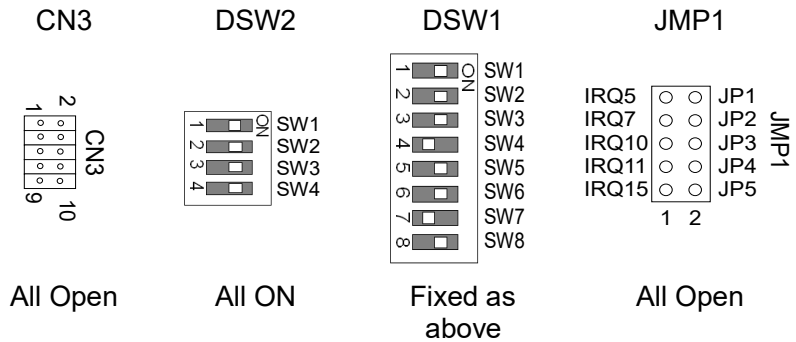

Specifications

Item	Specification
Name	EtherCAT board
Protocol	EtherCAT
Transmission Type	100BASE-TX
Baud Rate	100 M bps, full duplex
Maximum Segment Length	100m
Maximum Number of Nodes	65535
Cable	100BASE-TX(Cat5) with RJ45 connector
Interface	Two RJ45 ports IN: EtherCAT input / OUT: EtherCAT Output
Input Data Size	Max. 2048 bits (256 bytes)
Output Data Size	Max. 2048 bits (256 bytes)
Device Profile	CANopen over EtherCAT (CoE) PDO (Process Data Object) SDO (Service Data Object)

LED Description

LED state represents the states of the fieldbus board.

LED state	Link/Activity 1	RUN	ERR	Link/Activity 2
OFF	No IN port link	Initialized status	No error	No OUT port link
GRN	ON	IN port linking	Operational status	OUT port linking
	Blinking (Flickering)	IN port communication packet transmission and receiving	–	OUT port communication packet transmission and receiving
	Blinking (Blinking)	–	Preoperational status	–
	Blinking (Single flash)	–	Safe operational status	–
RED	ON	–	–	Critical error
	Blinking (Blinking)	–	–	EtherCAT communication configuration error
	Blinking (Single flash)	–	–	Communication synchronization
	Blinking (Double flash)	–	–	Watchdog error

LED's blinking patterns are as follows:

- Flickering : Repeats lighting on and off every 50 ms.
- Blinking : Repeats lighting on and off every 200 ms.
- Single flash : Repeats 200 ms of lighting on and 1000 ms c of lighting off.
- Double flash : Repeats a cycle of 200 ms of lighting on, 200 ms of lighting off, 200 ms of lighting on and 1000 ms of lighting off.

Setting Configure Switch

Configuration of an EtherCAT board is not necessary. All settings such as communication configuration for EtherCAT are done by Epson RC+ 8.0.

Wiring

Wiring of an EtherCAT slave board uses RJ45 connectors. Make sure to use STP-type 100BASE-TX cables.



CAUTION

- For cables and connectors, be sure to use a product complying with the industrial standards or a noise-resistant Ethernet cable (STP cable). If you use office use products or UTP cables, it may cause communication errors and may not offer the proper performance.

Installing a Board



WARNING

- Make sure that the power is turned OFF before installing/removing any boards or connecting/disconnecting any cables. Working with the power ON is extremely hazardous and may result in electrical shock and/or malfunction of equipment.

Install the board to the dedicated slot on the Robot Controller.

Reference manuals:

RC700 Series Maintenance MANUAL 7.1 Option Board

RC90 Series Maintenance MANUAL 7.1 Option Board

When using RC700-D and RC700-E, please contact the supplier of your region.

Confirmation with Epson RC+ 8.0

When an EtherCAT slave board is installed to the Controller, it is recognized automatically. Confirm whether Epson RC+ 8.0 has recognized the EtherCAT board using the following procedure.

1. Select [Setup]-[System Configuration] and display the [System Configuration] dialog box.
2. Select [Controller]-[Inputs / Outputs].

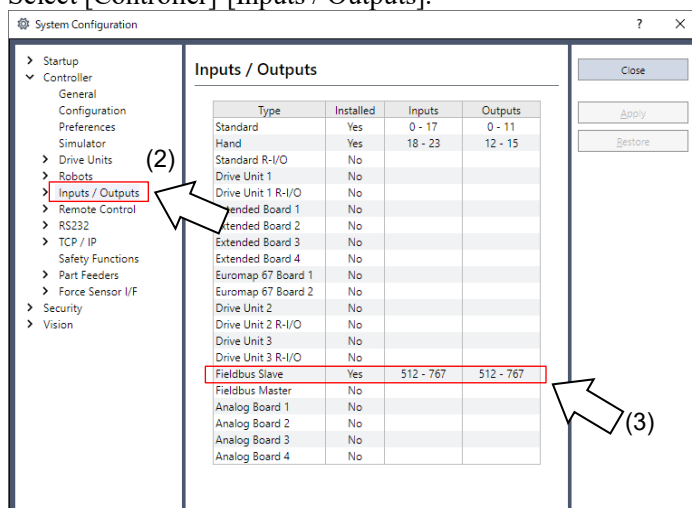

3. Confirm that the following items are displayed in “Fieldbus Slave”.

Installed : Yes
 Inputs : 512-767 (default setting)
 Outputs : 512-767 (default setting)

4. Select [Fieldbus Slave]-[General]

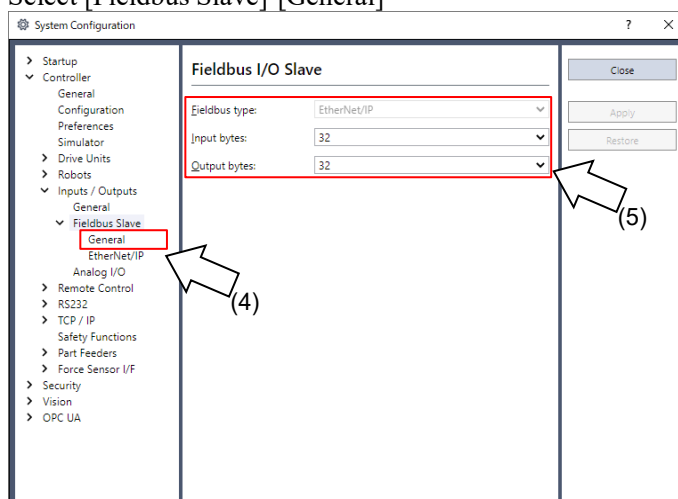

5. Confirm that the following items are displayed.

Fieldbus Type : EtherCAT
 Input Bytes : 32 (default setting)
 Output Bytes : 32 (default setting)

6. Click [Close].

Editing of Input / Output Size

You can change the input/output size of the EtherCAT slave board if necessary.

1. Select [Setup]-[System Configuration] and display the [System Configuration] dialog box.
2. Select [Controller]-[Inputs / Outputs]-[Fieldbus Slave]-[General].

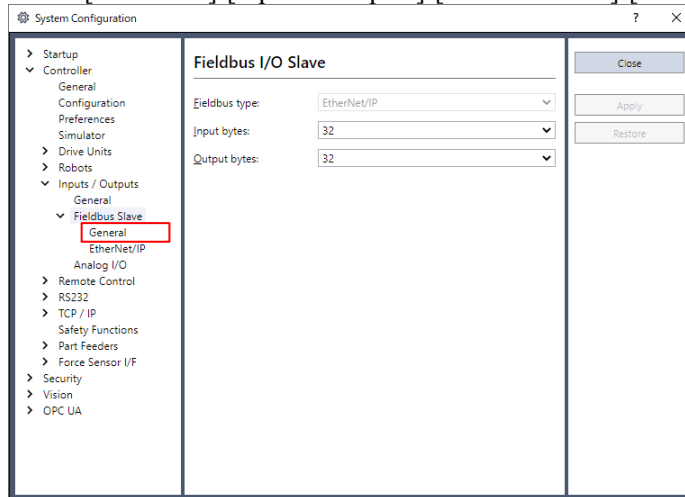

3. Change the settings of [Input Bytes] and [Output Bytes].
In this example, both of them are changed to 20 Bytes.

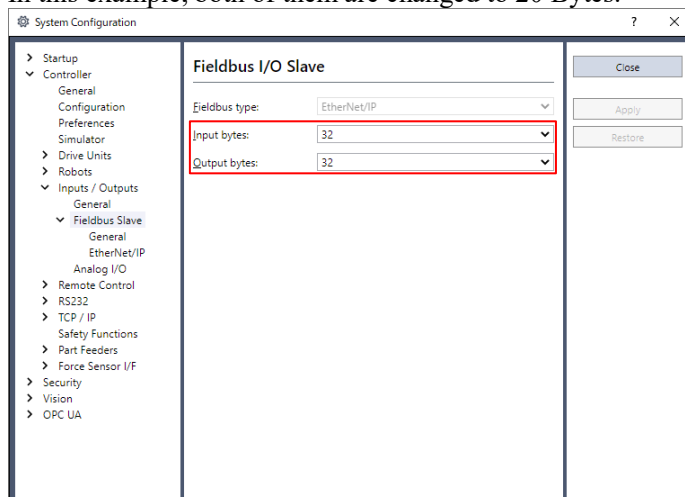

NOTE Cautions when connecting OMRON PLC and this option:

The input/output size has limitations.

Select any of 32 bytes, 64 bytes, 128 bytes, or 256 bytes for both [Input Bytes] and [Output Bytes].

[Input Bytes] and [Output Bytes] may have a different size.

4. Click [Apply].
5. Click [Close].

The following dialog box appears and the Controller automatically starts rebooting.



6. Select [Setup]-[System Configuration] and display the [System Configuration] dialog box.

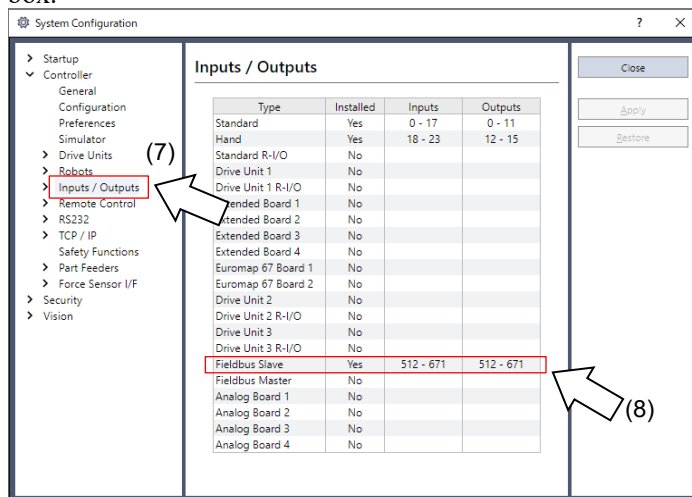

7. Select [Controller]-[Inputs / Outputs].
8. Confirm that the following items are displayed in "Fieldbus Slave".

Inputs : 512 – 512 + Changed number of input (Bits)
 Outputs : 512 – 512 + Changed number of output (Bits)

In this example, Input byte is 20 bytes (160 bits) and "512-671" is displayed in "Inputs".

Also, Output byte is 20 bytes (160 bits) and "512-671" is displayed in "Outputs".

9. Click [Close].

Communication State Transition

The EtherCAT slave board goes into initialized state after the power is turned ON. Subsequent state transition is controlled by the EtherCAT master.

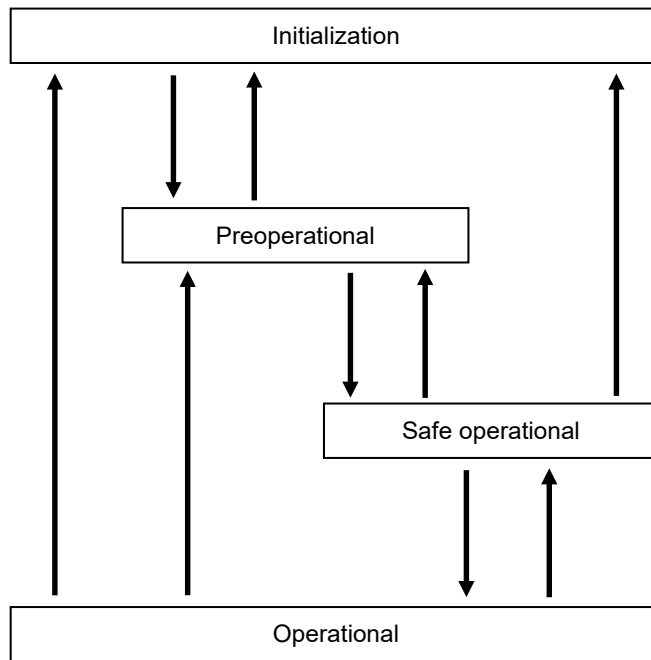

State	Description
Initialization	Status after turning ON the power. Initialization state is continued by the EtherCAT until preoperational state.
Preoperational	Set by the EtherCAT master. SDO (Service Data Object) communication is only available in this state.
Safe operational	Set by the EtherCAT master. PDO (Process Data Object) transmission, along with SDO (Service Data Object) communication is available in this state.
Operational	Set by the EtherCAT master. All communications are available in this state. Control of I/O data with the EtherCAT master is possible.

Electronic Information File (ESI file)

An ESI (EtherCAT Slave Information) file is supplied for EtherCAT slave board network configuration. The file is located in the following folder where Epson RC+ 8.0 is installed.

C:\EpsonRC80\Fieldbus\EtherCAT

Compatible list of ESI file

Controller	File name
RC700 series	Epson RC700_ECT rev1.00.xml
	EPSN RC700 ECT V2.3 for OMRON rev2.xml
RC90 series	Epson RC90_ECT rev1.00.xml
	EPSN RC90 ECT V2.3 for OMRON rev2.xml



When connecting the OMRON's PLC and this option:

Use the following ESI files specialized for the OMRON's PLC.

C:\EpsonRC80\Fieldbus\EtherCAT

EPSN_RC90_ECT_V2.3_for_OMRON_rev2.xml

EPSN_RC700_ECT_V2.3_for_OMRON_rev2.xml

On the OMRON's setting tool (Sysmac Studio), set as follows according to the input/output size set for this option and the data type (USINT/REAL).

USINT : Unsigned integer (1 byte)

REAL : Floating point (4 bytes)

When "32" bytes is set for [Input Bytes],

select "RxPDO(USINT32byte)" or "RxPDO(REAL32byte)"

When "64" bytes is set for [Input Bytes],

select "RxPDO(USINT64byte)" or "RxPDO(REAL64byte)"

When "128" bytes is set for [Input Bytes],

select "RxPDO(USINT128byte)" or "RxPDO(REAL128byte)"

When "256" bytes is set for [Input Bytes],

select two of "RxPDO(USINT128byte/256byte)" or "RxPDO(REAL256byte)"

When "32" bytes is set for [Output Bytes],

select "TxPDO(USINT32byte)" or "TxPDO(REAL32byte)"

When "64" bytes is set for [Output Bytes],

select "TxPDO(USINT64byte)" or "TxPDO(REAL64byte)"

When "128" bytes is set for [Output Bytes],

select "TxPDO(USINT128byte)" or "TxPDO(REAL128byte)"

When "256" bytes is set for [Output Bytes],

select two of "TxPDO(USINT128byte/256byte)" or "TxPDO(REAL256byte)"

Example:

When [Input] is "256" bytes and [Output] is "256" bytes on this option, settings on the OMRON's setting tool (Sysmac Studio) are as follows:

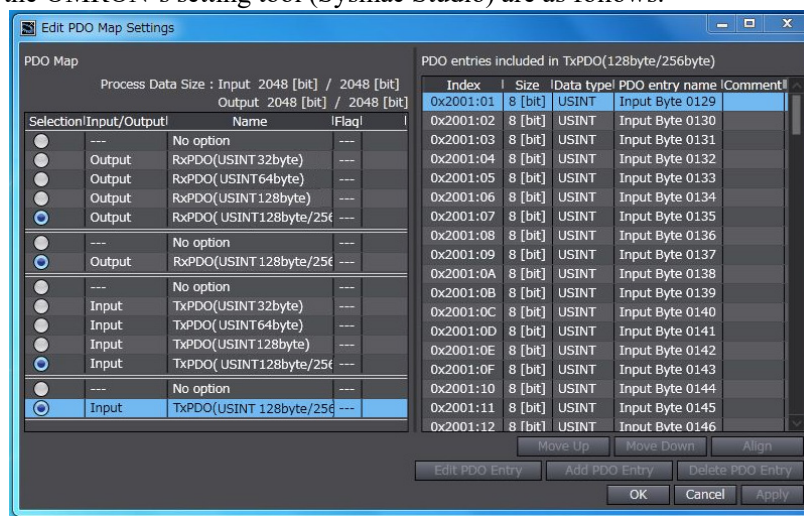



2.6.2 Installing EtherCAT Slave Module

 WARNING	<ul style="list-style-type: none"> Make sure that the power is turned OFF before installing/removing any modules or connecting/disconnecting any cables. Working with the power ON is extremely hazardous and may result in electrical shock and/or malfunction of equipment.
--	--

 CAUTION	<ul style="list-style-type: none"> Pay attention to the followings in order to prevent the the connecter from coming off. <ol style="list-style-type: none"> Use the connectors attached to the module. Insert the connectors all the way seated. Fix the cables at proper positions in order not to put a load on the connectors.
--	---

 CAUTION	<ul style="list-style-type: none"> Use the Controller firmware and the EtherCAT module in the following combinations. It does not guarantee the correct motions if you use any combination other than those listed below. <table border="1" style="margin-left: auto; margin-right: auto;"> <thead> <tr> <th>Controller</th> <th>Controller Firmware Version</th> <th>EtherCAT Module Version</th> </tr> </thead> <tbody> <tr> <td rowspan="3" style="text-align: center;">T/VT Series</td> <td style="text-align: center;">Before 7.5.54.14</td> <td style="text-align: center;">V.2.01</td> </tr> <tr> <td rowspan="2" style="text-align: center;">7.5.54.14 or later</td> <td style="text-align: center;">V.2.01</td> </tr> <tr> <td style="text-align: center;">V.2.24</td> </tr> </tbody> </table>	Controller	Controller Firmware Version	EtherCAT Module Version	T/VT Series	Before 7.5.54.14	V.2.01	7.5.54.14 or later	V.2.01	V.2.24
Controller	Controller Firmware Version	EtherCAT Module Version								
T/VT Series	Before 7.5.54.14	V.2.01								
	7.5.54.14 or later	V.2.01								
		V.2.24								

NOTE  Refer to *Epson RC+ 8.0 User's Guide "[System Configuration] Command (Setup Menu)" [Setup]-[System Configuration]-[Controller]-[Preferences]* to check the firmware version.

NOTE  The module version of EtherCAT is indicated on the label on the back of the module.



Appearance

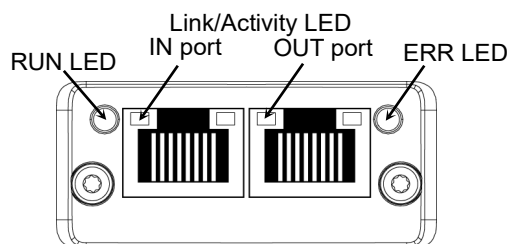

Specifications

Item	Specification	
Name	EtherCAT module	
Protocol	EtherCAT	
Transmission Type	100BASE-TX	
Baud Rate	100 M bps, full duplex	
Maximum Segment Length	100m	
Maximum Number of Nodes	65535	
Cable	100BASE-TX(Cat5) with RJ45 connector	
Interface	Two RJ45 ports IN: EtherCAT input / OUT: EtherCAT Output	
Max. Input Data Size	RC800 series	T/VT series
	4096 bits (512 bytes)	2048 bits (256 bytes)
Max. Output Data Size	RC800 series	T/VT series
	4096 bits (512 bytes)	2048 bits (256 bytes)
Device Profile	CANopen over EtherCAT (CoE) PDO (Process Data Object) SDO (Service Data Object)	

NOTE If a slave module receives NOP commands, it is possible to be not connected to a master device properly.
 Set the master to not send NOP commands.

LED Description

LED state represents the states of the fieldbus Module.

RUN LED

LED State	Indication	Description
OFF	INIT	EtherCAT device in 'INIT'-state (or no power)
Green	OPERATIONAL	EtherCAT device in 'OPERATIONAL'-state
Green, blinking	PRE-OPERATIONAL	EtherCAT device in 'PRE-OPERATIONAL'-state
Green, single flash	SAFE-OPERATIONAL	EtherCAT device in 'SAFE-OPERATIONAL'-state
Flickering	BOOT	The EtherCAT device is in 'BOOT' state
Red	(Fatal Event)	If RUN and ERR turn red, this indicates a fatal event, forcing the bus interface to a physically passive state.

ERR LED

LED State	Indication	Description
OFF	No error	No error (or no power)
Red, blinking	Invalid configuration	State change received from master is not possible due to invalid register or object settings.
Red, single flash	Unsolicited state change	Slave device application has changed the EtherCAT state autonomously.
Red, double flash	Application watchdog timeout	Sync manager watchdog timeout.
Red	Application Controller failure	Anybus module in EXCEPTION. If RUN and ERR turn red, this indicates a fatal event, forcing the bus interface to a physically passive state.
Flickering	Booting error detected	E.g. due to firmware download failure.

Link/Activity

LED State	Indication	Description
OFF	No link	Link not sensed (or no power)
Green	Link sensed, no activity	Link sensed, no traffic detected
Green, flickering	Link sensed, activity	Link sensed, traffic detected

Setting Configure Switch

Configuration of an EtherCAT module is not necessary. All settings such as communication configuration for EtherCAT are done by Epson RC+ 8.0.

Wiring

Wiring of an EtherCAT slave board uses RJ45 connectors. Make sure to use STP-type 100BASE-TX cables.



CAUTION

- For cables and connectors, be sure to use a product complying with the industrial standards or a noise-resistant Ethernet cable (STP cable). If you use office use products or UTP cables, it may cause communication errors and may not offer the proper performance.

Installing Module



WARNING

- Make sure that the power is turned OFF before installing/removing any modules or connecting/disconnecting any cables. Working with the power ON is extremely hazardous and may result in electrical shock and/or malfunction of equipment.

Install the module to the dedicated slot on the Controller.

Reference manuals:

T series MAINTENANCE MANUAL 14.6 Fieldbus I/O

T-B series MAINTENANCE MANUAL 14.5 Fieldbus I/O

VT series MAINTENANCE MANUAL 18.7 Fieldbus I/O

RC800 series Service Manual 4.1.3 Fieldbus I/O Module

Confirmation with Epson RC+ 8.0

When an EtherCAT slave module is installed to the Controller, it is recognized automatically. Confirm whether Epson RC+ 8.0 has recognized the EtherCAT module using the following procedure.

1. Select [Setup]-[System Configuration] and display the [System Configuration] dialog box.
2. Select [Controller]-[Inputs / Outputs].

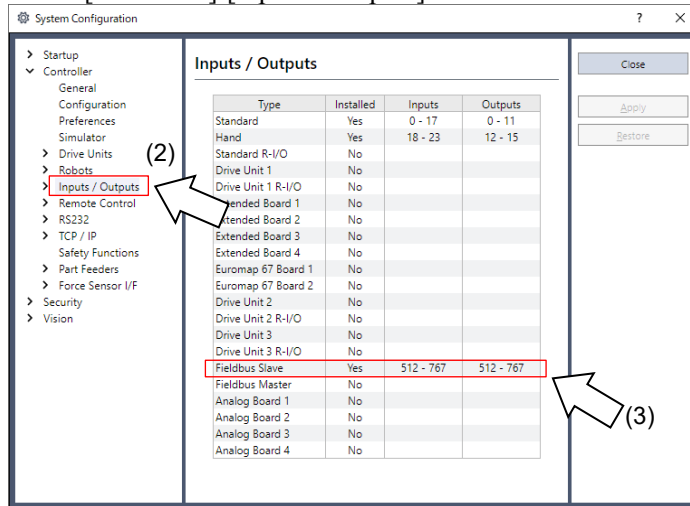

3. Confirm that the following items are displayed in “Fieldbus Slave”.

Installed : Yes
 Inputs : 512-767 (default setting)
 Outputs : 512-767 (default setting)

4. Select [Fieldbus Slave]-[General]

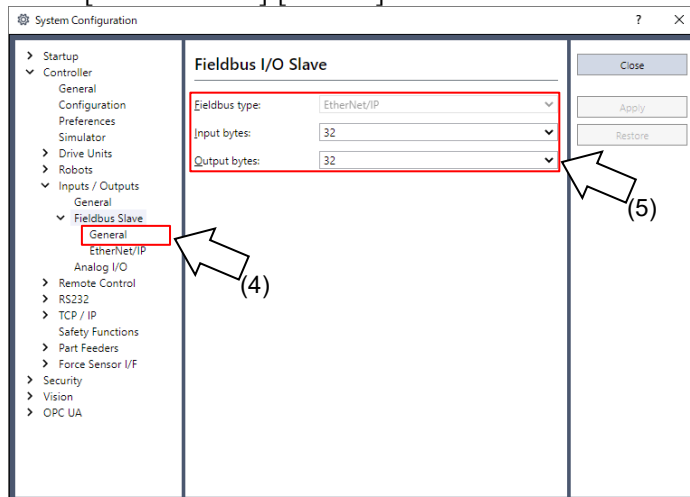

5. Confirm that the following items are displayed.

Fieldbus Type : EtherCAT
 Input Bytes : 32 (default setting)
 Output Bytes : 32 (default setting)

6. Click [Close].

Editing of Input / Output Size

You can change the input/output size of the EtherCAT slave module if necessary.

1. Select [Setup]-[System Configuration] and display the [System Configuration] dialog box.
2. Select [Controller]-[Inputs / Outputs]-[Fieldbus Slave]-[General].

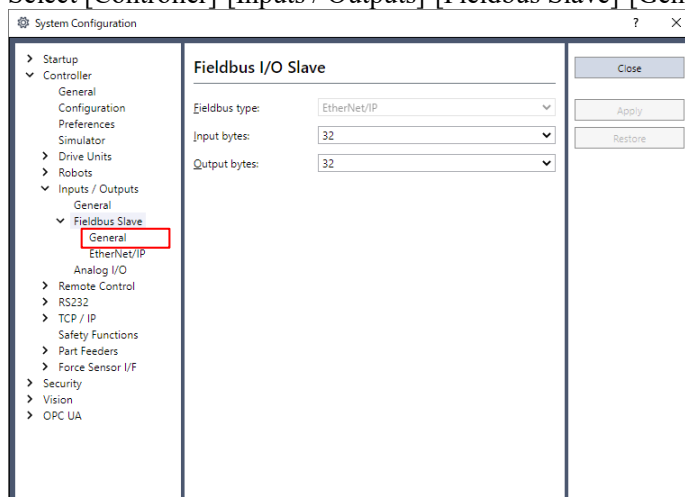

3. Change the settings of [Input Bytes] and [Output Bytes]. In this example, both of them are changed to "20" Bytes.

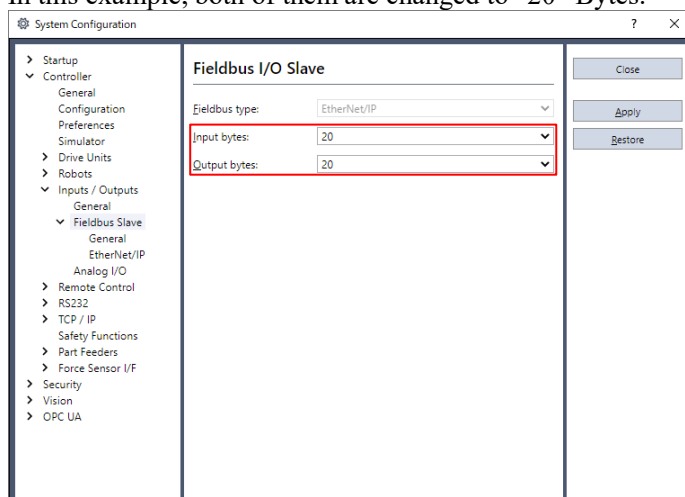

NOTE Cautions when connecting OMRON PLC and this option:

The input/output size has limitations.

Select any of 32 bytes, 64 bytes, 128 bytes, or 256 bytes for both [Input Bytes] and [Output Bytes].

[Input Bytes] and [Output Bytes] may have a different size.

4. Click [Apply].
5. Click [Close]
The following dialog box appears and the Controller automatically starts rebooting.



6. Select [Setup]-[System Configuration] and display the [System Configuration] dialog box.
7. Select [Controller]-[Inputs / Outputs].

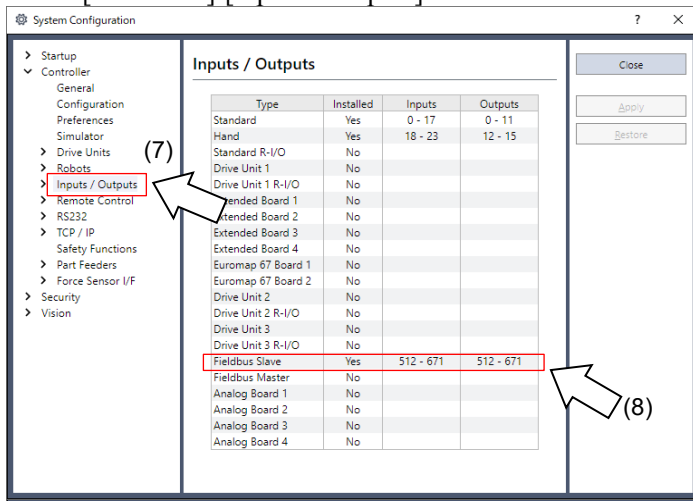

8. Confirm that the following items are displayed in “Fieldbus Slave”.

Inputs : 512 – 512 + Changed number of input (Bits)
 Outputs : 512 – 512 + Changed number of output (Bits)

In this example, Input byte is 20 bytes (160 bits) and “512-671” is displayed in “Inputs”.

Also, Output byte is 20 bytes (160 bits) and “512-671” is displayed in “Outputs”.

9. Click [Close].

Communication State Transition

The EtherCAT slave module goes into initialized state after the power is turned ON. Subsequent state transition is controlled by the EtherCAT master.

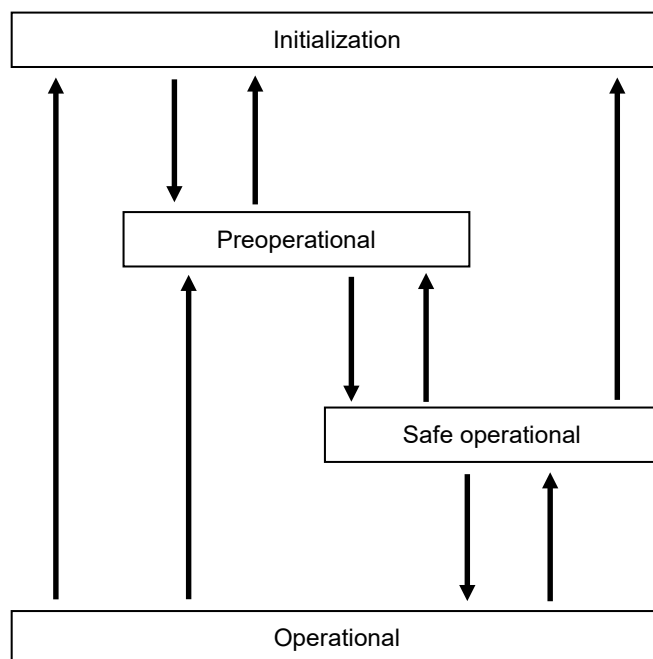

State	Description
Initialization	Status after turning ON the power. Initialization state is continued by the EtherCAT until preoperational state.
Preoperational	Set by the EtherCAT master. SDO (Service Data Object) communication is only available in this state.
Safe operational	Set by the EtherCAT master. PDO (Process Data Object) transmission, along with SDO (Service Data Object) communication is available in this state.
Operational	Set by the EtherCAT master. All communications are available in this state. Control of I/O data with the EtherCAT master is possible.

Electronic Information File (ESI file)

An ESI (EtherCAT Slave Information) file is supplied for EtherCAT slave module network configuration. The file is located in the following folder where Epson RC+ 8.0 is installed.

C:\EpsonRC80\Fieldbus\EtherCAT

Use in the following combinations.

Compatible list of ESI file

Controller	Controller Firmware Version	EtherCAT Module Version	File Name
T/VT Series	Before 7.5.54.14	V.2.01	Epson TSERIES_ECT rev1.00.xml
			EPSN_TSERIES_ECT_V2.3_for_OMRON_rev2.xml
	7.5.54.14 or later	V.2.01	Epson TSERIES_ECT rev1.00.xml
			EPSN_TSERIES_ECT_V2.3_for_OMRON_rev2.xml
		V.2.24	Epson TSERIES_ECT rev1.10.xml
RC800 Series	In all versions	V.2.24	Epson RC800_ECT rev1.00.xml
			Epson RC800_ECT Manual_Setting rev1.00.xml



When connecting the OMRON's PLC and this option:

Use the following ESI files specialized for the OMRON's PLC.

C:\EpsonRC80\Fieldbus\EtherCAT

EPSN_TSERIES_ECT_V2.3_for_OMRON_rev2.xml

Epson RC800_ECT Manual_Setting rev1.00.xml

On the OMRON's setting tool (Sysmac Studio), set as follows according to the input/output size set for this option and the data type (USINT/REAL).

USINT : Unsigned integer (1 byte)

REAL : floating point (4 bytes)

When "32" bytes is set for [Input Bytes],

select "RxPDO(USINT32byte)" or "RxPDO(REAL32byte)"

When "64" bytes is set for [Input Bytes],

select "RxPDO(USINT64byte)" or "RxPDO(REAL64byte)"

When "128" bytes is set for [Input Bytes],

select "RxPDO(USINT128byte)" or "RxPDO(REAL128byte)"

When "256" bytes is set for [Input Bytes],

select two of "RxPDO(128byte/256byte)" or "RxPDO(REAL256byte)"

When "512" bytes is set for [Input Bytes],

select four of "RxPDO(128byte/512byte)" or "RxPDO(REAL512byte)"

When "32" bytes is set for [Output Bytes],

select "TxPDO(USINT32byte)" or "TxPDO(REAL32byte)"

When "64" bytes is set for [Output Bytes],

select "TxPDO(USINT64byte)" or "TxPDO(REAL64byte)"

When "128" bytes is set for [Output Bytes],

select "TxPDO(USINT128byte)" or "TxPDO(REAL128byte)"

When "256" bytes is set for [Output Bytes],

select two of "TxPDO(USINT128byte/256byte)" or "TxPDO(REAL256byte)"

When "512" bytes is set for [Output Bytes],

select four of "TxPDO(USINT128byte/512byte)" or "TxPDO(REAL512byte)"

Example:

When [Input] is “256” bytes and [Output] is “256” bytes on this option, settings on the OMRON’s setting tool (Sysmac Studio) are as follows:

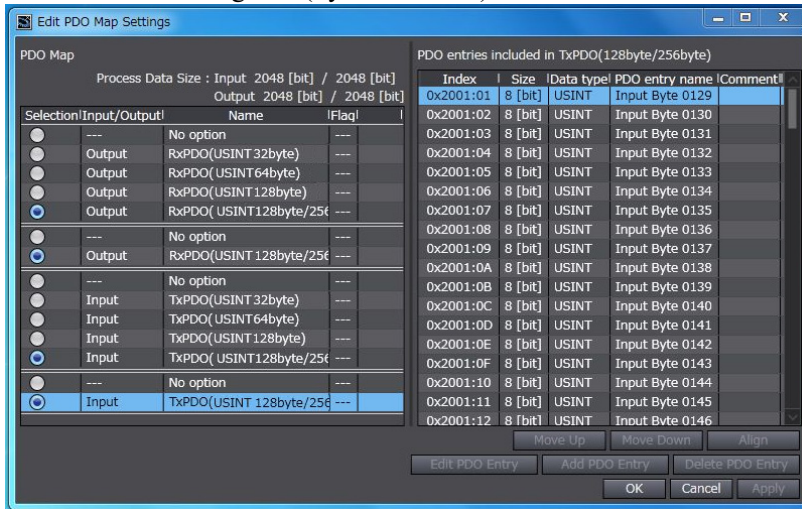

3. Operation

This chapter describes how to use the Fieldbus I/O option after installing it.

3.1 SPEL⁺ Fieldbus I/O Commands

Here are the main commands for Fieldbus I/O. Input/output command and function for fieldbus I/O are same as these for the normal I/O. For details, refer to the *Online Help* or *SPEL⁺ Language Reference manual*.

FbusIO GetBusStatus	Returns the status of the specified fieldbus.
FbusIO GetDeviceStatus	Returns the status of the specified fieldbus device.
FbusIO SendMsg	Sends an explicit message to a device and returns the reply.
In	Returns the status of an 8-bit input port.
InW	Returns the status of a 16-bit input port.
IONumber	Returns the I/O port number of the specified Fieldbus I/O label.
Off	Turns an output OFF.
On	Turns an output ON.
Out	Simultaneously sets eight output bits.
OutW	Simultaneously sets 16 output bits.
Sw	Returns the status of one input bit.



Response times for Fieldbus I/O varies and depends on several factors, including baud rate, scan rate, number of tasks, communication error, etc. Epson RC+ does not guarantee the real-time response for the fieldbus I/O and message inputs. When the fastest and most consistent response times are required, please use Epson Standard digital I/O, which incorporates interrupt driven inputs and outputs.

3.2 Outputs Off by Emergency Stop and Reset Instruction

You can configure the system so that all outputs including the fieldbus outputs will be turned OFF when the emergency stop occurs and when a Reset instruction is executed.

For details of the configuration, refer to the *Epson RC+ User's Guide*.



A command that was issued just before an emergency stop can be executed after the emergency stop condition is cleared. If the outputs from the fieldbus involve risk, the “Outputs off during Emergency Stop” option should be enabled to remove all power to output devices when an emergency stop occurs.

3.3 Using FbusIO_SendMsg

To use FbusIO_SendMsg, install the Fieldbus master board.

FbusIO_SendMsg is used to send an explicit message to a device and return a reply. This command operates according to the protocol.

The syntax is as follows:

```
FbusIO_SendMsg bus, device, msgParam, sendBytes(), recvBytes()
```

Description of parameter

There are two arrays passed to the parameter. The sendData array contains the data that is sent to the device in bytes. This array must be dimensioned to the correct number of bytes to send. If there are no bytes to send, you must use "0" for the parameter. The recvData array returns the response in bytes. This array is automatically re-dimensioned to the number of bytes received.

For DeviceNet, you need to initialize the sendData array with the command, class, instance, and attribute, as shown in the example below. Consult the documentation that came with the device for the values that can be used. The msgParam parameter value is always "0" for DeviceNet messages.

Here is an example for DeviceNet and EtherNet/IP:

The following example acquires the information of a device MacID = 1.

```
' Send explicit message to the device
Byte sendData(5)
Byte recvData(10)
Integer i
sendData(0) = 14 ' Command (GetAttributeSingle)
sendData(1) = 1 ' Class
sendData(3) = 1 ' Instance
sendData(5) = 7 ' Attribute
FbusIO_SendMsg 16, 1, 0, sendData(), recvData()
For i = 0 To UBound(recvData)
    Print recvData(i)
Next i
```

For PROFIBUS DP, you need to specify the service number in the msgParam parameter. Consult the documentation that came with the device for the services that are supported. Some services require "0" send bytes. In this case, use "0" for the sendBytes parameter.

Here is an example for PROFIBUS DP:

```
' Send message to Profibus device
Byte recvData(10)
Integer i
' Service 56 - read all inputs
' sendBytes = 0
FbusIO_SendMsg 1, 1, 56, 0, recvData()
For i = 0 To UBound(recvData)
    Print recvData(i)
Next i
```

3.4 Explicit Message Connection (for DeviceNet, EtherNet/IP)

Issuing an Explicit message from the DeviceNet/EtherNet/IP master unit to the Robot System acquires and configures the DeviceNet and EtherNet/IP I/O area.

Supported function and Class ID configurations are as follows:

When using Assembly Object Class (Class ID = 4)

Function	Class ID	Instance	Service Code
Input acquisition	4 (04h)	100 (64h)	14 (0Eh)
Output configuration	4 (04h)	150 (96h)	16 (10h)
Output acquisition	4 (04h)	150 (96h)	14 (0Eh)

When using I/O Data Mapping Object Class (Class ID = 160, 161)

Function	Class ID	Instance	Service Code
Input acquisition	160 (A0h)	01 (01h)	14 (0Eh)
Output configuration	161 (A1h)	01 (01h)	16 (10h)
Output acquisition	161 (A1h)	01 (01h)	14 (0Eh)

Command response

It can acquire up to 32 bytes* input/output data.

* It depends on the input/output size setting.

3.5 Setting Remote Control Input and Output

Remote control inputs and outputs are not allocated to fieldbus I/O by default.

To allot remote control inputs and outputs to fieldbus I/O, follow the steps below.

1. Select Epson RC+ 8.0 menu-[Setup]-[System Configuration] and display the [System Configuration] dialog box. Select-[Controller]-[Remote Control]-[Inputs] or [Outputs].

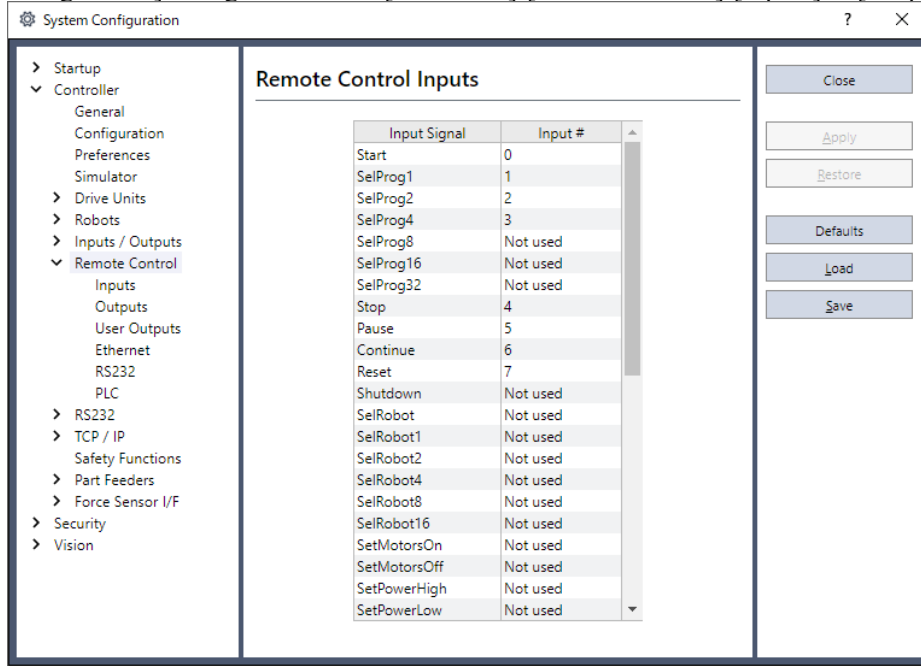

2. Click [Defaults] to display the [Default Remote Type] dialog box.

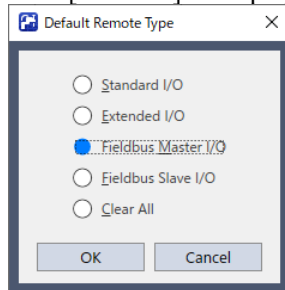

3. Select [Fieldbus Master I/O] or [Fieldbus Slave I/O] and click [OK].
4. Fieldbus I/O will be allotted default remote control input and output setting. Select bit numbers by clicking the input or output numbers corresponding to the signals to be used for remote control.
5. Click [Apply] to save the settings. Then, click [Close].

To enable the remote control, refer to *Epson RC+ 8.0 User's Guide Remote Control*.

Default Remote Control Input Setting for Fieldbus Master I/O

Default remote control input settings for fieldbus master I/O are as follows:

Input Signal	Robot System Input Bit No
Start	6144
SelProg1	6145
SelProg2	6146
SelProg4	6147
SelProg8	Not used
SelProg16	Not used
SelProg32	Not used
Stop	6148
Pause	6149
Continue	6150
Reset	6151
Shutdown	6155
SelRobot1	Not used
SelRobot2	Not used
SelRobot4	Not used
SelRobot8	Not used
SelRobot16	Not used
SetMotorsOn	6152
SetMotorsOff	6153
SetPowerHigh	Not used
SetPowerLow	Not used
ForcePowerLow	Not used
Home	6154
MCal	Not used
Recover	Not used
ExtCmdSet	Not used
ExtRespGet	Not used
ExtCmdReset	Not used
ExtCmd_0-15	Not used
ExtCmd_16-31	Not used
ExtCmd_32-47	Not used
ExtCmd_48-63	Not used
ExtCmd_64-79	Not used
ExtCmd_80-95	Not used
ExtCmd_96-111	Not used
ExtCmd_112-127	Not used

Default Remote Control Output Setting for Fieldbus Master I/O

Default remote control output settings for fieldbus master I/O are as follows:

Output Signal	Robot System Output Bit No
Ready	6144
Running	6145
Paused	6146
Error	6147
EStopOn	Not used
EStopOff	6175
SafeguardOn	6149
SError	6150
Warning	6151
MotorsOn	6152
AtHome	6153
PowerHigh	Not used
MCalReqd	Not used
RecoverReqd	Not used
RecoverInCycle	Not used
WaitingRC	Not used
CmdRunning	6173
CmdError	6174
CurrProg1	6154
CurrProg2	6155
CurrProg4	6156
CurrProg8	Not used
CurrProg16	Not used
CurrProg32	Not used
AutoMode	6157
TeachMode	6158
TestMode	Not used
EnableOn	Not used
ErrorCode1	6159
ErrorCode2	6160
ErrorCode4	6161
ErrorCode8	6162
ErrorCode16	6163
ErrorCode32	6164
ErrorCode64	6165
ErrorCode128	6166
ErrorCode256	6167
ErrorCode512	6168
ErrorCode1024	6169
ErrorCode2048	6170
ErrorCode4096	6171
ErrorCode8192	6172
InsideBox1	Not used

Output Signal	Robot System Output Bit No
InsideBox2	Not used
InsideBox3	Not used
InsideBox4	Not used
InsideBox5	Not used
InsideBox6	Not used
InsideBox7	Not used
InsideBox8	Not used
InsideBox9	Not used
InsideBox10	Not used
InsideBox11	Not used
InsideBox12	Not used
InsideBox13	Not used
InsideBox14	Not used
InsideBox15	Not used
InsidePlane1	Not used
InsidePlane2	Not used
InsidePlane3	Not used
InsidePlane4	Not used
InsidePlane5	Not used
InsidePlane6	Not used
InsidePlane7	Not used
InsidePlane8	Not used
InsidePlane9	Not used
InsidePlane10	Not used
InsidePlane11	Not used
InsidePlane12	Not used
InsidePlane13	Not used
InsidePlane14	Not used
InsidePlane15	Not used
ExtCmdGet	Not used
ExtRespSet	Not used
ExtCmdResult	Not used
ExtError	Not used
ExtResp_0-15	Not used
ExtResp_16-31	Not used
ExtResp_32-47	Not used
ExtResp_48-63	Not used
ExtResp_64-79	Not used
ExtResp_80-95	Not used
ExtResp_96-111	Not used
ExtResp_112-127	Not used

Default Remote Control Input Setting for Fieldbus Slave I/O

Default remote control input settings for fieldbus slave I/O are as follows:

Input Signal	Robot System Input Bit No
Start	512
SelProg1	513
SelProg2	514
SelProg4	515
SelProg8	Not used
SelProg16	Not used
SelProg32	Not used
Stop	516
Pause	517
Continue	518
Reset	519
Shutdown	523
SelRobot1	Not used
SelRobot2	Not used
SelRobot4	Not used
SelRobot8	Not used
SelRobot16	Not used
SetMotorsOn	520
SetMotorsOff	521
SetPowerHigh	Not used
SetPowerLow	Not used
ForcePowerLow	Not used
Home	522
MCal	Not used
Recover	Not used
ExtCmdSet	Not used
ExtRespGet	Not used
ExtCmdReset	Not used
ExtCmd_0-15	Not used
ExtCmd_16-31	Not used
ExtCmd_32-47	Not used
ExtCmd_48-63	Not used
ExtCmd_64-79	Not used
ExtCmd_80-95	Not used
ExtCmd_96-111	Not used
ExtCmd_112-127	Not used

Default Remote Control Output Setting for Fieldbus Slave I/O

Default remote control output settings for fieldbus slave I/O are as follows:

Output Signal	Robot System Output Bit No
Ready	512
Running	513
Paused	514
Error	515
EStopOn	Not used
EStopOff	543
SafeguardOn	517
SError	518
Warning	519
MotorsOn	520
AtHome	521
PowerHigh	Not used
MCalReqd	Not used
RecoverReqd	Not used
RecoverInCycle	Not used
WaitingRC	Not used
CmdRunning	541
CmdError	542
CurrProg1	522
CurrProg2	523
CurrProg4	524
CurrProg8	Not used
CurrProg16	Not used
CurrProg32	Not used
AutoMode	525
TeachMode	526
EnableOn	Not used
ErrorCode1	527
ErrorCode2	528
ErrorCode4	529
ErrorCode8	530
ErrorCode16	531
ErrorCode32	532
ErrorCode64	533
ErrorCode128	534
ErrorCode256	535
ErrorCode512	536
ErrorCode1024	537
ErrorCode2048	538
ErrorCode4096	539
ErrorCode8192	540
InsideBox1	Not used
InsideBox2	Not used

Output Signal	Robot System Output Bit No
InsideBox3	Not used
InsideBox4	Not used
InsideBox5	Not used
InsideBox6	Not used
InsideBox7	Not used
InsideBox8	Not used
InsideBox9	Not used
InsideBox10	Not used
InsideBox11	Not used
InsideBox12	Not used
InsideBox13	Not used
InsideBox14	Not used
InsideBox15	Not used
InsidePlane1	Not used
InsidePlane2	Not used
InsidePlane3	Not used
InsidePlane4	Not used
InsidePlane5	Not used
InsidePlane6	Not used
InsidePlane7	Not used
InsidePlane8	Not used
InsidePlane9	Not used
InsidePlane10	Not used
InsidePlane11	Not used
InsidePlane12	Not used
InsidePlane13	Not used
InsidePlane14	Not used
InsidePlane15	Not used
ExtCmdGet	Not used
ExtRespSet	Not used
ExtCmdResult	Not used
ExtError	Not used
ExtResp_0-15	Not used
ExtResp_16-31	Not used
ExtResp_32-47	Not used
ExtResp_48-63	Not used
ExtResp_64-79	Not used
ExtResp_80-95	Not used
ExtResp_96-111	Not used
ExtResp_112-127	Not used

4. Troubleshooting

4.1 DeviceNet Troubleshooting

Exclusion

Every system has its special environment, conditions, specifications, and usages. This guide is provided as a general reference for troubleshooting a DeviceNet network. Every effort has been made to ensure the information is accurate. However, we do not guarantee the complete accuracy of the information and thus we decline any liability for damages or costs incurred by the use of this troubleshooting.

Before examining a problem on the network, please ensure that your established DeviceNet system satisfies network specifications. (Refer to this troubleshooting and the section *2.1.2 DeviceNet Network Construction*.)

Tools

Prepare the following tools for troubleshooting.

- Philips screwdriver
- Flat-blade screwdriver
- Tester

4.1.1 Examining a Problem

4.1.1.1 Scanner Board Diagnostic LEDs

The DeviceNet master board used with Epson RC+ has two status display LEDs. The layout of the LEDs is shown in the following figure.

PCU-DVNIO

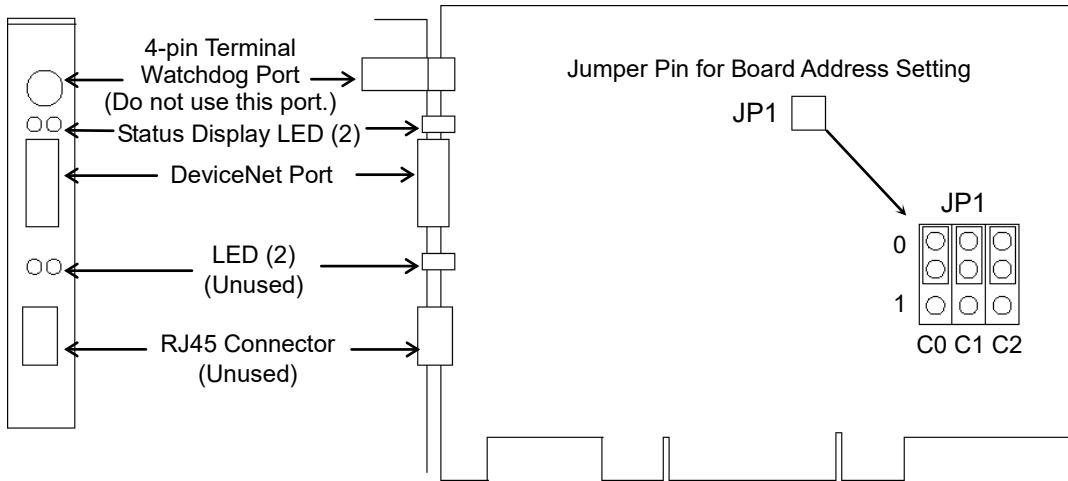

The Module/NetWork LED is on the left side and the IO LED is on the right side seen from the rear panel. These LED names are used in applicomIO Console application and this manual. Only in this troubleshooting section, general names of the status display of the DeviceNet device are used.

The Module/NetWork LED is referred to as the Network Status (NS) in this section.

The IO LED is referred to as the Module Status LED (MS) in this section.

4.1.1.2 Checking Network Status

1. Master Status: MS/NS LEDs

LED	Color	Light Condition
MS (Module Status)	<input type="checkbox"/> Green <input type="checkbox"/> Red	<input type="checkbox"/> ON <input type="checkbox"/> Blinking <input type="checkbox"/> OFF
NS (Network Status)	<input type="checkbox"/> Green <input type="checkbox"/> Red	<input type="checkbox"/> ON <input type="checkbox"/> Blinking <input type="checkbox"/> OFF

2. Node Number of Absent Slaves

Absent slaves are disconnected from or not added to the network.

2-1 See the status flag regarding to the removal and addition if the master has status information.

2-2 See the MS/NE LEDs of all slaves if the master has no status information.

3. Absent Slave Status: MS/NS LEDs

LED	Color	Light Condition
MS (Module Status)	<input type="checkbox"/> Green <input type="checkbox"/> Red	<input type="checkbox"/> ON <input type="checkbox"/> Blinking <input type="checkbox"/> OFF
NS (Network Status)	<input type="checkbox"/> Green <input type="checkbox"/> Red	<input type="checkbox"/> ON <input type="checkbox"/> Blinking <input type="checkbox"/> OFF

4. Physical Node Location of Absent Slave

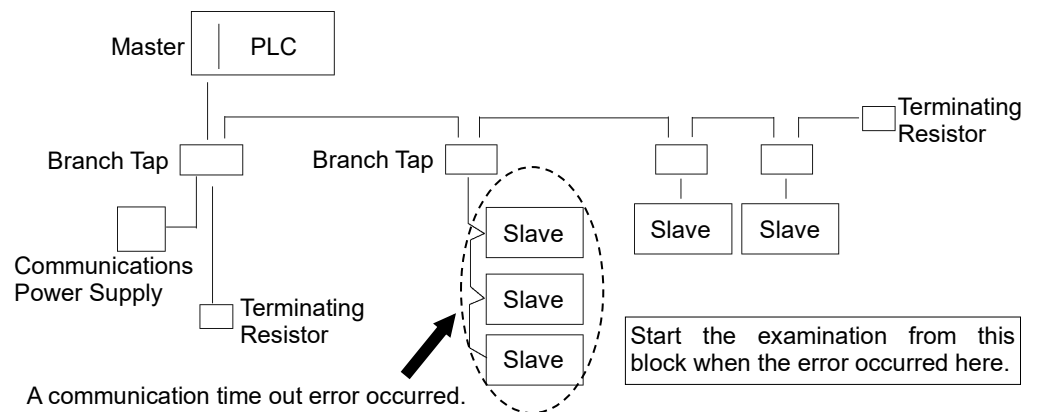

5. Error Occurrence Condition

- Immediate occurrence (high reproducibility)
- Rare occurrence (low reproducibility)

4.1.2 Problems and Countermeasures

Master Unit LED		Error	Description [Reference]
MS	NS		
Green Light ON	Green Light ON	Normal communication	- Normal condition
Green Light ON	Green Light Blinking	During connection establishment	- Processing connection establishment (The NS LED will be ON in green in a few seconds.) - Master function in stop state (When communication does not start, master analysis with NetMeter is required.)
Green Light ON	Red Light Blinking	Communication error	[Refer to the section 4.1.2.1 Master: Communication Error.] - Slave disconnected from the network (Remote I/O communication error) - Slave not added to the network (Scan list collation error) - Communications power supply OFF (Error detection after the communication establishment)
Green Light ON	Red Light ON	Busoff detection Duplicate MAC ID	[Refer to the section 4.1.2.2 Master: Busoff Detection.] - Busoff detection: Communication stopped due to critical error. - Duplicate MAC ID: The MAC ID configuration was duplicated. (This error occurs only during unit start-up)
Green Light ON	Light OFF	Unestablished communication	[Refer to the section 4.1.2.3 Master: Unestablished Communication.] - No slave (Error detection before communication establishment) - Communications power supply OFF (Error detection before the communication establishment) - Duplicate MAC ID: The MAC ID configuration was duplicated.
Red Light Blinking	No Matter	Configuration error	- Master unit configuration error Refer to the respective device manuals. When Epson RC+ was configured as a master: [Refer to the section 4.1.2.4 Master: Configuration Error.] - Slave disconnected from the network (Remote I/O communication error) - Slave not added to the network (Scan list collation error) - Duplicate MAC ID: The MAC ID configuration was duplicated.
Red Light ON	No Matter	Module error	- Broken master unit → Unit Replacement
Light OFF	Green Light Blinking	Absent slave	[Refer to the section 4.1.2.5 Absent Slave.] - No slave (Error detection before communication establishment) - Communications power supply OFF
Light OFF	Light OFF	Uninitialized network Absent slave	[Refer to the section 4.1.2.6 Uninitialized Network.] - Master unit start-up error - No slave (Error detection before communication establishment) - Communications power supply OFF

◆ Process Flowchart

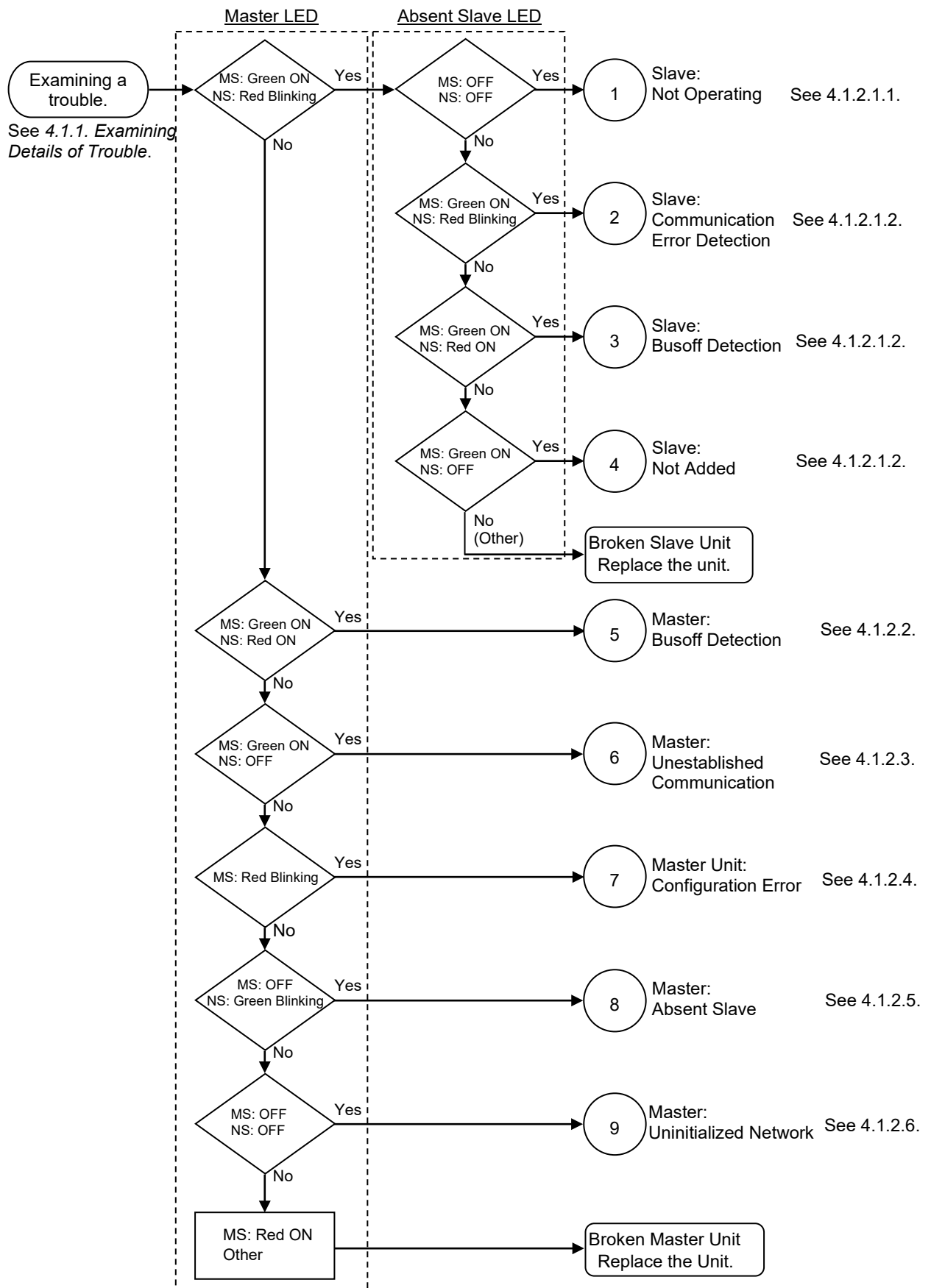

4.1.2.1 Master: Communication Error

Master Unit LED		Error	Description
MS	NS		
Green Light ON	Red Light Blinking	Communication error	- Slave disconnected from the network (Remote I/O communication error) - Slave not added to the network (Scan list collation error) - Communications power supply OFF (Error detection after the communication establishment)

Slave: Not Operating

	MS	NS
Master LED Condition	Green Light ON	Red Light Blinking
Absent Slave LED Condition	Light OFF	Light OFF

◆ Process Flowchart

Check

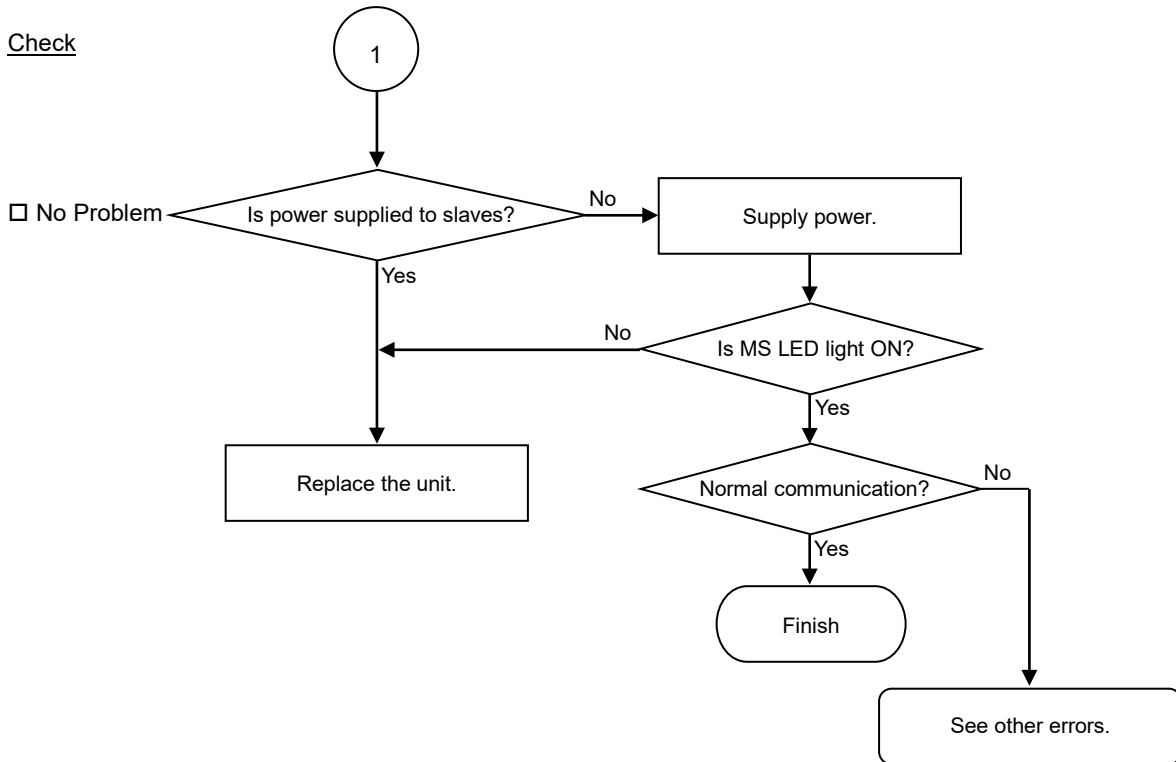

◆ Causes of Error

Possible Cause	Examination Method	Countermeasure
○ Slave power OFF	Measure the power voltage of the slaves. (It should be within the range of sufficient voltage for the slave operation.) NOTE: For slaves operating with communications power supply, measure voltage at the DeviceNet connector.	Supply power to the slave.
○ Broken unit	Slave unit replacement	Replace the broken slave unit with a new one.

Slave: Communication Error Detection / Busoff Detection / Not-added

	MS	NS
Master LED Condition	Green Light ON	Red Light Blinking
(1) Absent Slave LED Condition (Communication error detection)	Green Light ON	Red Light Blinking
(2) Absent Slave LED Condition (Busoff detection)	Green Light ON	Red Light ON
(3) Absent Slave LED Condition (Slave not added to the network)	Green Light ON	Light OFF

4. Troubleshooting (DeviceNet)

◆ Process Flowchart

Check

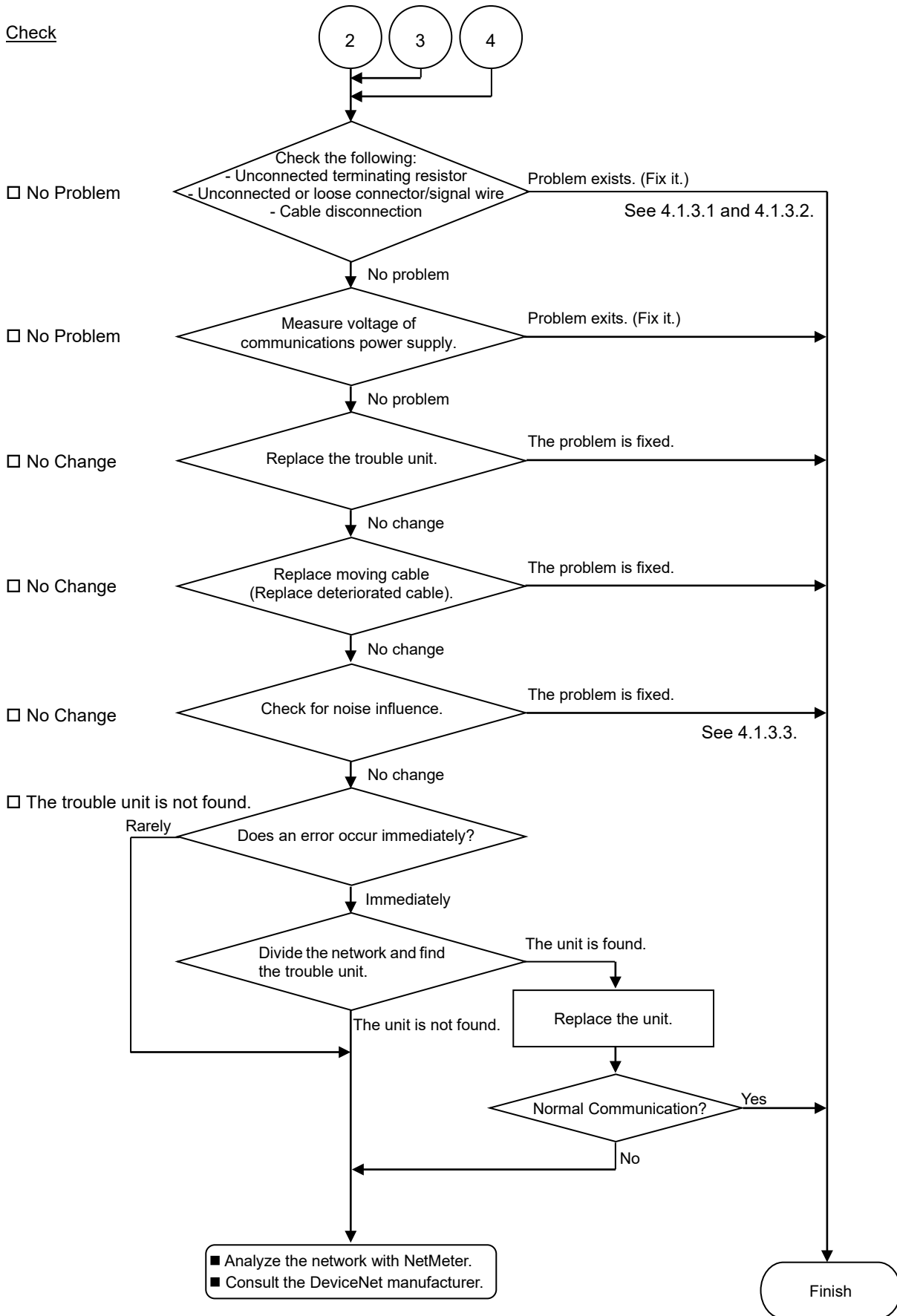

◆ Causes of Error

Possible Cause	Examination Method	Countermeasure
<ul style="list-style-type: none"> ○ Disconnected terminating resistors ○ Cable disconnection ○ Disconnected connector ○ Disconnected signal wire 	<p>(1) Check that terminating resistors are connected to both ends of the network.</p> <p>(2) Measure resistance between signal wires with communications power supply OFF. → Normal: 50 to 70 Ω</p> <ul style="list-style-type: none"> ● Measuring point: Connection of the trouble unit ● For details, refer to the section 4.1.3.1 <i>Connection Problem</i>. 	<p>Fix the problem.</p> <p>How to find the trouble point: Remove the terminating resistor on one end of the network. The trouble point is where resistance changes from 120 Ω.</p>
<ul style="list-style-type: none"> ○ Loose connector ○ Loose signal wire 	<p>Check for the connection of connectors and signal wires. → The connectors and signal wires should be firmly connected.</p> <ul style="list-style-type: none"> ● Checkpoint: all nodes and all branch taps ● For details, refer to the section 4.1.3.2 <i>Loose Connector and Signal Wire</i>. 	<p>Connect the connectors and signal wires again.</p>
<ul style="list-style-type: none"> ○ Voltage drop of communications power supply 	<p>Measure voltage of communications power supply at the unit with a trouble. → Normal: 11V or more between V+ and V-</p> <ul style="list-style-type: none"> ● If the voltage is 11 to 14 V, the unit is a possible cause. Fix the problem on the unit. 	<p>Check the voltage of the power supply. Calculate the current capacity of the cable and add more communications power supplies.</p>
<ul style="list-style-type: none"> ○ Noise (external cause) 	<p>Check the noise intrusion via the following paths (1) to (3).</p> <ol style="list-style-type: none"> (1) Noise via DRAIN (FG) (2) Induced noise via communication cable (3) Communications power supply <p>→ For details, refer to the section 4.1.3.3 <i>Noise Intrusion</i>.</p>	<p>Take countermeasures against noise.</p>
<ul style="list-style-type: none"> ○ Broken unit 	<p>Replace the broken unit with a new one. → Verify whether the problem is fixed.</p>	<p>Replace the unit with a new one.</p>
<ul style="list-style-type: none"> ● No cause is identified. 	<p>Identify the trouble point by dividing the network. → For details, refer to the section 4.1.3.4 <i>Broken Unit Examination</i>.</p>	

4. Troubleshooting (DeviceNet)

4.1.2.2 Master: Busoff Detection

Master Unit LED		Error	Description
MS	NS		
Green Light ON	Red Light ON	Busoff detection	Communication stopped due to critical error.
		Duplicate MAC ID	The MAC ID configuration was duplicated. (This error occurs only during unit start-up)

◆ Process Flowchart

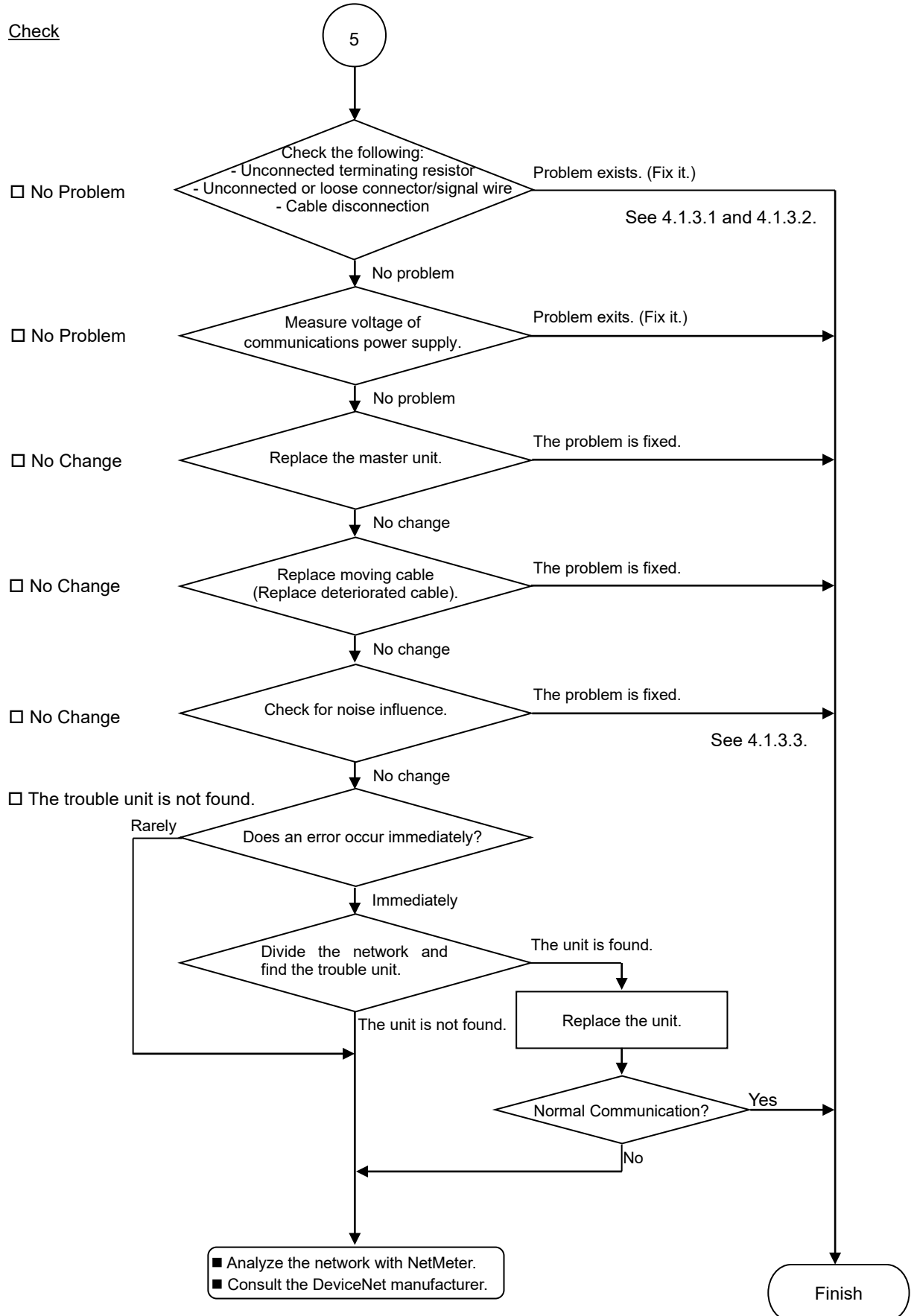

◆ Causes of Error

Possible Cause	Examination Method	Countermeasure
<ul style="list-style-type: none"> ○ Disconnected terminating resistors ○ Cable disconnection ○ Disconnected connector ○ Disconnected signal wire 	<p>(1) Check that terminating resistors are connected to both ends of the network.</p> <p>(2) Measure resistance between signal wires with communications power supply OFF.</p> <p>→ Normal: 50 to 70 Ω</p> <ul style="list-style-type: none"> ● Measuring point: Connection of the problem unit ● For details, refer to the section <i>4.1.3.1 Connection Problem.</i> 	<p>Fix the problem.</p> <p>How to find the trouble point: Remove the terminating resistor on one end of the network. The trouble point is where resistance changes from 120 Ω.</p>
<ul style="list-style-type: none"> ○ Loose connector ○ Loose signal wire 	<p>Check for the connection of connectors and signal wires.</p> <p>→ The connectors and signal wires should be firmly connected.</p> <ul style="list-style-type: none"> ● Checkpoint: all nodes and all branch taps ● For details, refer to the section <i>4.1.3.2 Loose Connector and Signal Wire.</i> 	<p>Connect the connectors and signal wires again.</p>
<ul style="list-style-type: none"> ○ Voltage drop of communications power supply 	<p>Measure voltage of communications power supply at the trouble unit.</p> <p>→ Normal: 11V or more between V+ and V-</p> <ul style="list-style-type: none"> ● If the voltage is 11 to 14 V, the unit is a possible cause. Fix the problem on the unit. 	<p>Check the voltage of the power supply. Calculate the current capacity of the cable and add more communications power supplies.</p>
<ul style="list-style-type: none"> ○ Noise (external cause) 	<p>Check the noise intrusion via the following paths (1) to (3).</p> <p>(1) Noise via DRAIN (FG)</p> <p>(2) Induced noise via communication cable</p> <p>(3) Communications power supply</p> <p>→ For details, refer to the section <i>4.1.3.3 Noise Intrusion.</i></p>	<p>Take countermeasures against noise.</p>
<ul style="list-style-type: none"> ○ Broken unit 	<p>Replace the broken unit with a new one.</p> <p>→ Verify whether the problem is fixed.</p>	<p>Replace the unit with a new one.</p>
<ul style="list-style-type: none"> ● No cause is identified. 	<p>Identify the trouble point by dividing the network.</p> <p>→ For details, refer to the section <i>4.1.3.4 Broken Unit Examination.</i></p>	

4.1.2.3 Master: Unestablished Communication

Master Unit LED		Error	Description
MS	NS		
Green Light ON	Light OFF	Master Unestablished communication	Communications power supply OFF No slave

◆ Process Flowchart

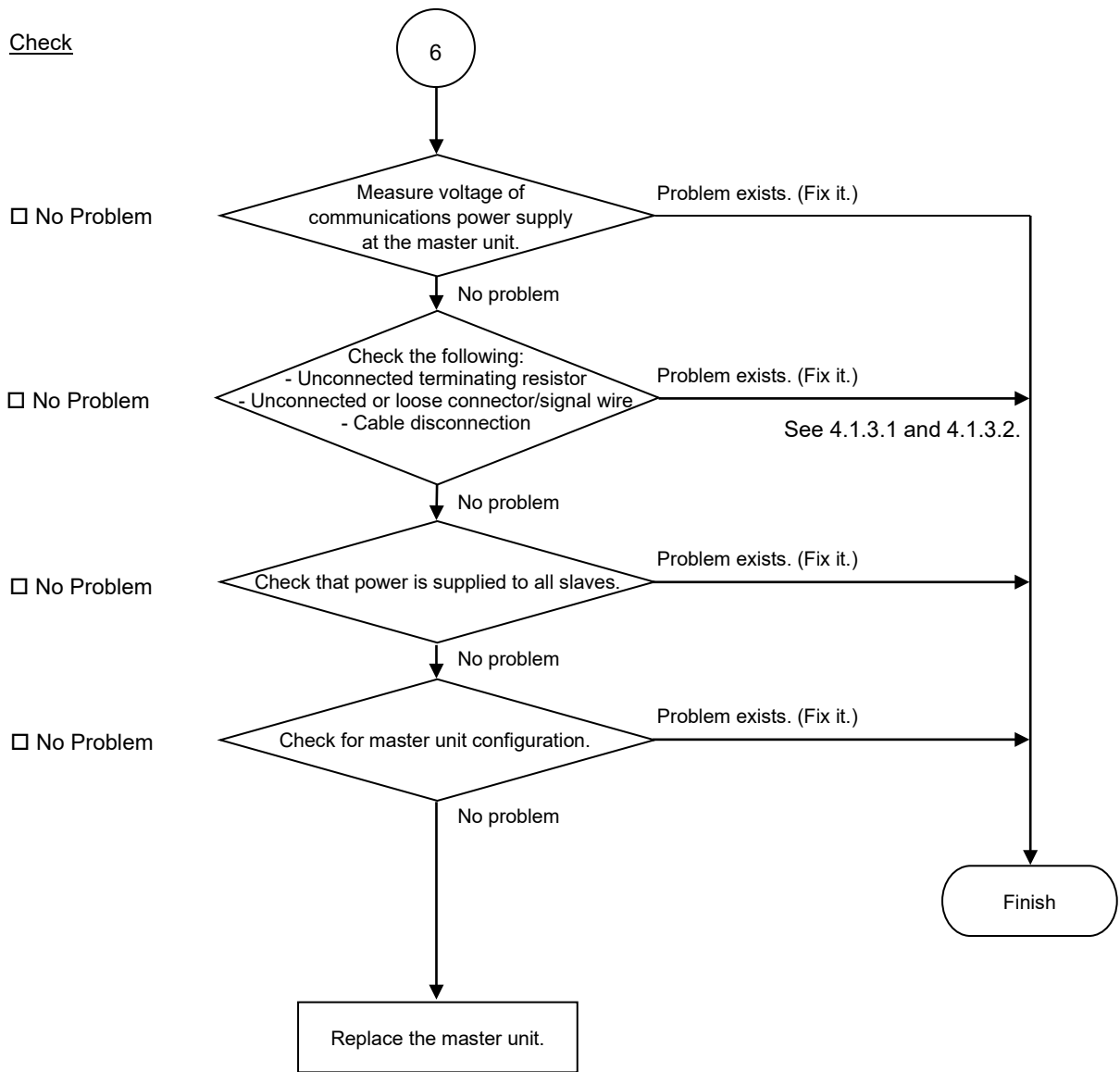

◆ Causes of Error

Possible Cause	Examination Method	Countermeasure
○ Voltage drop of communications power supply	Measure voltage of communications power supply at the master unit. → Normal: 11V or more between V+ and V- ● If the voltage is 11 to 14 V, the master unit is a possible cause. Fix the problem on it.	Check voltage of the power supply.
○ Disconnected terminating resistors ○ Cable disconnection ○ Disconnected connector ○ Disconnected signal wire	(1) Check that terminating resistors are connected to both ends of the network. (2) Measure resistance between signal wires with communications power supply OFF. → Normal: 50 to 70Ω ● Measuring point: Connection of the master ● For details, refer to the section <i>4.1.3.1 Connection Problem.</i>	Fix the problem. How to find the trouble point: Remove the terminating resistor on one end of the network. The trouble point is where resistance changes from 120 Ω.
○ Loose connector ○ Loose signal wire	Check for the connection of connectors and signal wires. → The connectors and signal wires should be firmly connected. ● Checkpoint: Between the master and its slaves ● For details, refer to the section <i>4.1.3.2 Loose Connector and Signal Wire.</i>	Connect the connectors and signal wires again.
○ All slaves power OFF	Measure the power voltage of the slaves. (It should be within the range of sufficient voltage for slave operation.)	Supply power to the slaves.
○ Master unit configuration	(1) Start applicomIO Console application and check that the configuration has no difference with the network condition. (2) Check that the configuration data were written in flash. ● For details, refer to the section <i>4.1.3.6 Epson RC+ Master Configuration.</i>	Change the configuration.

4.1.2.4 Master: Configuration Error

Master Unit LED		Error	Description
MS	NS		
Red Light Blinking	No Matter	Configuration error Slave error detection	<ul style="list-style-type: none">- Slave disconnected from the network (Remote I/O communication error)- Slave not added to the network (Scan list collation error)- Duplicate MAC ID: The MAC ID configuration was duplicated.

4. Troubleshooting (DeviceNet)

◆ Process Flowchart

Check

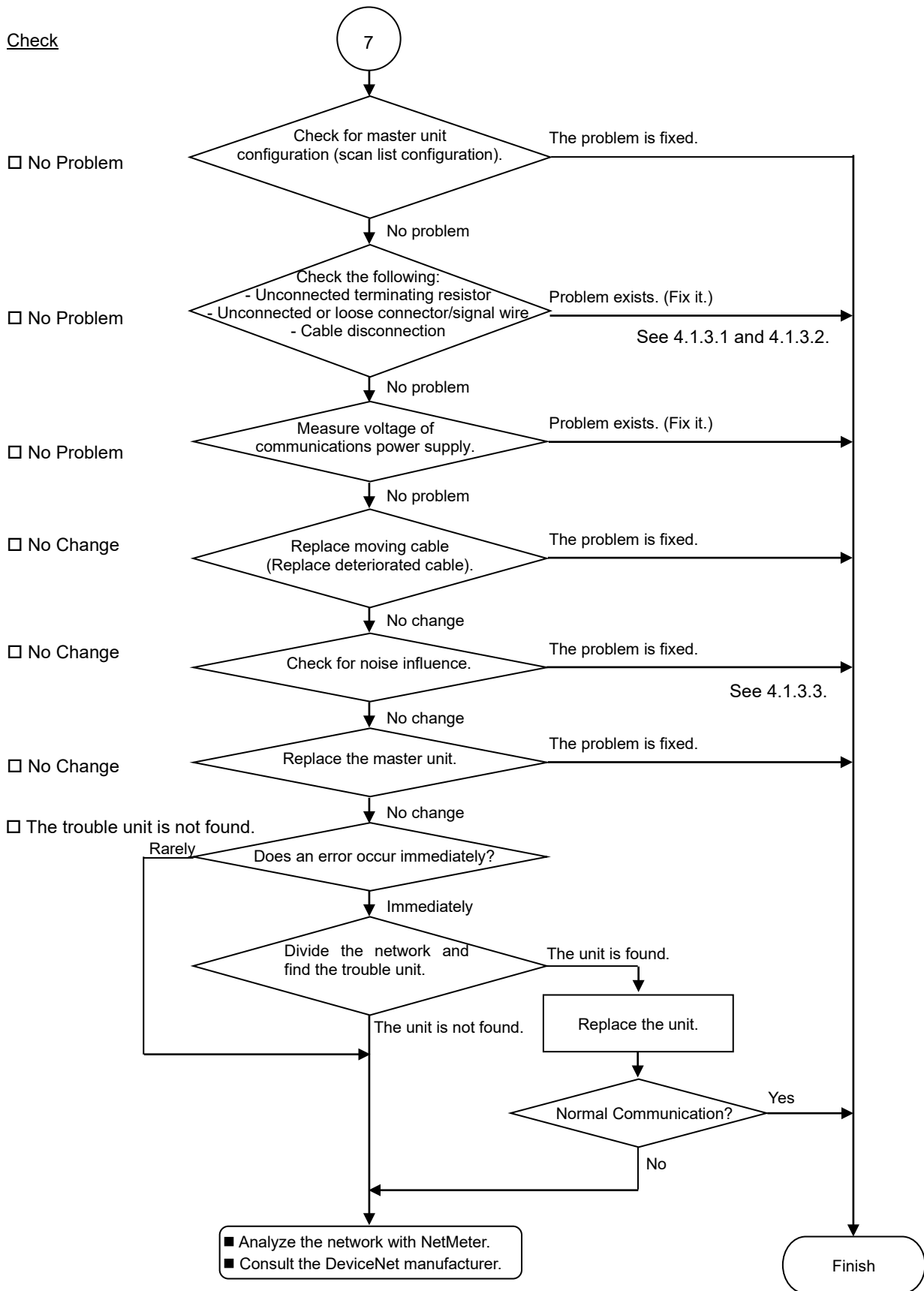

◆ Causes of Error

Possible Cause	Examination Method	Countermeasure
○ Master unit configuration	(1) Start applicomIO Console application and check that the configuration has no difference with the network condition. (2) Check that the configuration data were written in flash. (3) Check that the network load is within allowable range. ● For details, refer to the section <i>4.1.3.6 Epson RC+ Master Configuration</i> .	Change the configuration.
○ Disconnected terminating resistors ○ Cable disconnection ○ Disconnected connector ○ Disconnected signal wire	(1) Check that terminating resistors are connected to both ends of the network. (2) Measure resistance between signal wires with communications power supply OFF. → Normal: 50 to 70Ω ● Measuring point: Connection of the trouble unit ● For details, refer to the section <i>4.1.3.1 Connection Problem</i> .	Fix the problem. How to find the trouble point: Remove the terminating resistor on one end of the network. The trouble point is where resistance changes from 120 Ω.
○ Loose connector ○ Loose signal wire	Check for the connection of connectors and signal wires. → The connectors and signal wires should be firmly connected. ● Checkpoint: all nodes and all branch taps ● For details, refer to the section <i>4.1.3.2 Loose Connector and Signal Wire</i> .	Connect the connectors and signal wires again.
○ Voltage drop of communications power supply	Measure voltage of communications power supply at the unit with a trouble. → Normal: 11V or more between V+ and V- ● If the voltage is 11 to 14 V, the unit is a possible cause. Fix the problem on the unit.	Check the voltage of the power supply. Calculate the current capacity of the cable and add more communications power supplies.
○ Noise (external cause)	Check the noise intrusion via the following paths (1) to (3). (1) Noise via DRAIN (FG) (2) Induced noise via communication cable (3) Communications power supply → For details, refer to the section <i>4.1.3.3 Noise Intrusion</i> .	Take countermeasures against noise.
○ Broken unit	Replace the broken unit with a new one. → Verify whether the problem is fixed.	Replace the unit with a new one.
● No cause is identified.	Identify the trouble point by dividing the network. → For details, refer to the section <i>4.1.3.4 Broken Unit Examination</i> .	

4.1.2.5 Absent Slave

Master Unit LED		Error	Description
MS	NS		
Light OFF	Green Light Blinking	Absent slave	- No slave (Error detection before communication establishment) - Communications power supply OFF

◆ Process Flowchart

Check

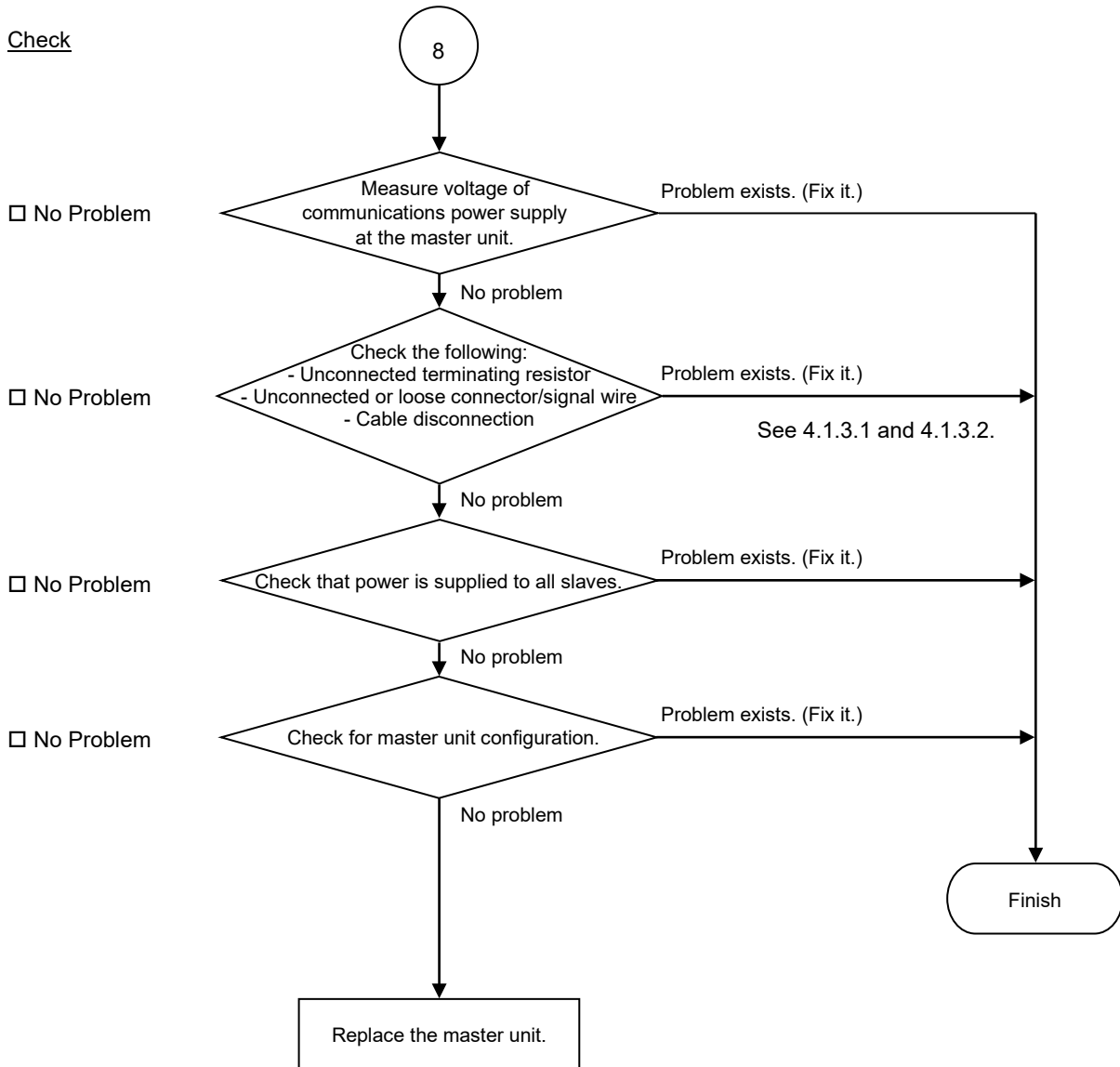

◆ Causes of Error

Possible Cause	Examination Method	Countermeasure
○ Voltage drop of communications power supply	Measure voltage of communications power supply at the master unit. → Normal: 11V or more between V+ and V- ● If the voltage is 11 to 14 V, the unit is a possible cause. Fix the problem on the unit.	Check voltage of the power supply.
○ Disconnected terminating resistors ○ Cable disconnection ○ Disconnected connector ○ Disconnected signal wire	(1) Check that terminating resistors are connected to both ends of the network. (2) Measure resistance between signal wires with communications power supply OFF. → Normal: 50 to 70 Ω ● Measuring point: Connection of the master ● For details, refer to the section <i>4.1.3.1 Connection Problem</i> .	Fix the problem. How to find the trouble point: Remove the terminating resistor on one end of the network. The trouble point is where resistance changes from 120 Ω.
○ Loose connector ○ Loose signal wire	Check for the connection of connectors and signal wires. → The connectors and signal wires should be firmly connected. ● Checkpoint: Between the master and its slaves ● For details, refer to the section <i>4.1.3.2 Loose Connector and Signal Wire</i> .	Connect the connectors and signal wires again.
○ All slaves power OFF	Measure the power voltage of the slaves. (It should be within the range of sufficient voltage for the slave operation.)	Supply power to the slaves.
○ Master unit configuration	(1) Start applicomIO Console application and check that the configuration has no difference with the network condition. (2) Check that the configuration data were written in flash. ● For details, refer to the section <i>4.1.3.6 Epson RC+ Master Configuration</i> .	Change the configuration.

4.1.2.6 Uninitialized Network

Master Unit LED		Error	Description
MS	NS		
Light OFF	Light OFF	Uninitialized network Absent slave	- Master unit start-up error - No slave (Error detection before communication establishment) - Communications power supply OFF

◆ Process Flowchart

Check

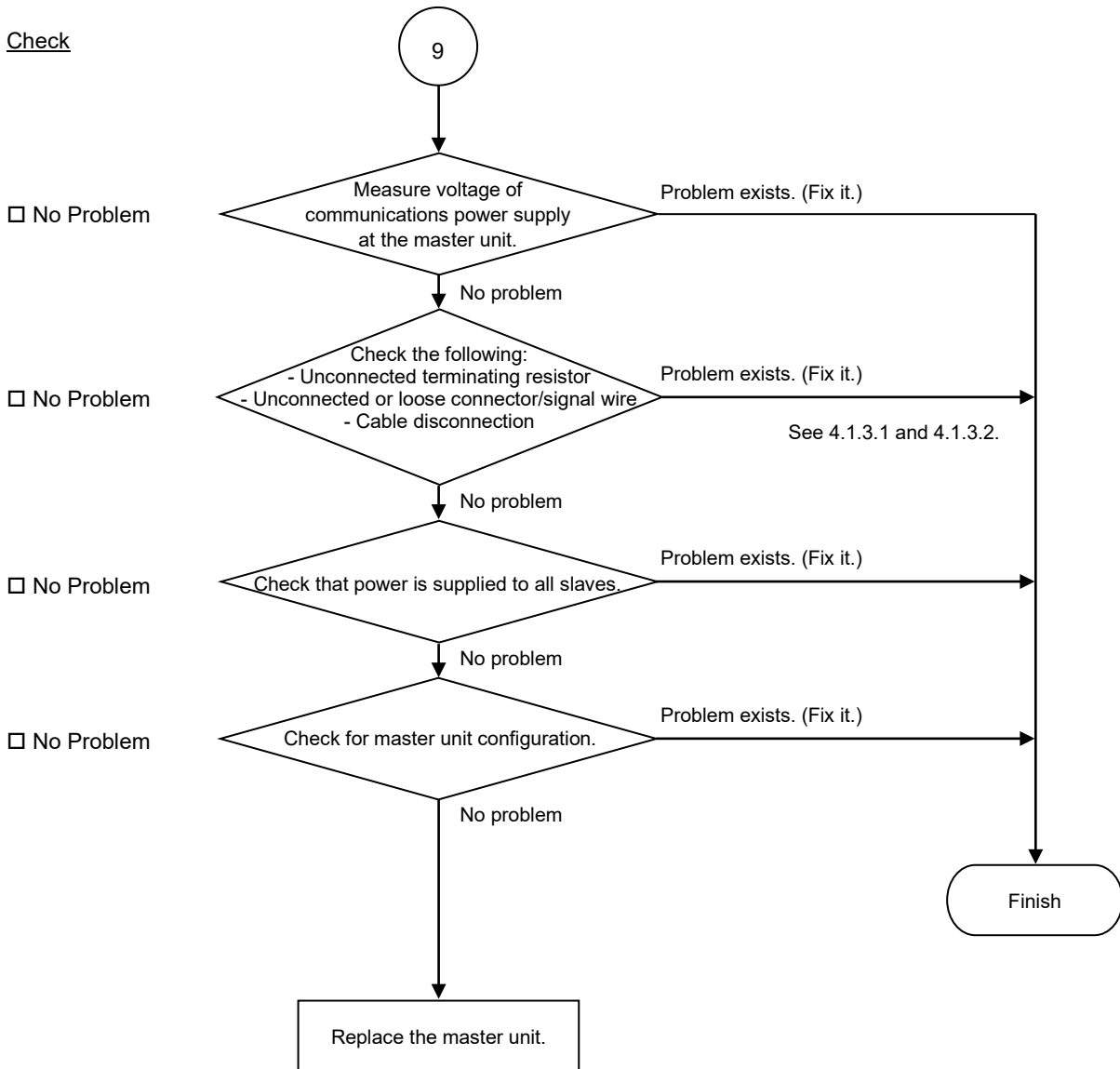

◆ Causes of Error

Possible Cause	Examination Method	Countermeasure
○ Voltage drop of communications power supply	Measure voltage of communications power supply at the master unit. → Normal: 11V or more between V+ and V- ● If the voltage is 11 to 14 V, the master unit is a possible cause. Fix the problem on it.	Check voltage of the power supply.
○ Disconnected terminating resistors ○ Cable disconnection ○ Disconnected connector ○ Disconnected signal wire	(1) Check that terminating resistors are connected to both ends of the network. (2) Measure resistance between signal wires with communications power supply OFF. → Normal: 50 to 70 Ω ● Measuring point: Connection of the master ● For details, refer to the section <i>4.1.3.1 Connection Problem</i> .	Fix the problem. How to find the trouble point: Remove the terminating resistor on one end of the network. The trouble point is where resistance changes from 120 Ω.
○ Loose connector ○ Loose signal wire	Check for the connection of connectors and signal wires. → The connectors and signal wires should be firmly connected. ● Checkpoint: Between the master and its slaves ● For details, refer to the section <i>4.1.3.2 Loose Connector and Signal Wire</i> .	Connect the connectors and signal wires again.
○ All slaves power OFF	Measure the power voltage of the slaves. (It should be within the range of sufficient voltage for slave operation.)	Supply power to the slaves.
○ Master unit configuration	(1) Start applicomIO Console application and check that the configuration has no difference with the network condition. (2) Check that the configuration data were written in flash. ● For details, refer to the section <i>4.1.3.6 Epson RC+ Master Configuration</i> .	Change the configuration.

4.1.3 Procedures for Examining Possible Causes

4.1.3.1 Connection Problem (Disconnected Terminating Resistors, Cable Disconnection, Disconnected Connector, and Disconnected Signal Wire)

1. Ensure that two terminating resistors are connected to both ends of the network.
2. Turn OFF the communications power supply.
3. Measure resistance between CAN_H and CAN_L wires of the absent slave using the tester.

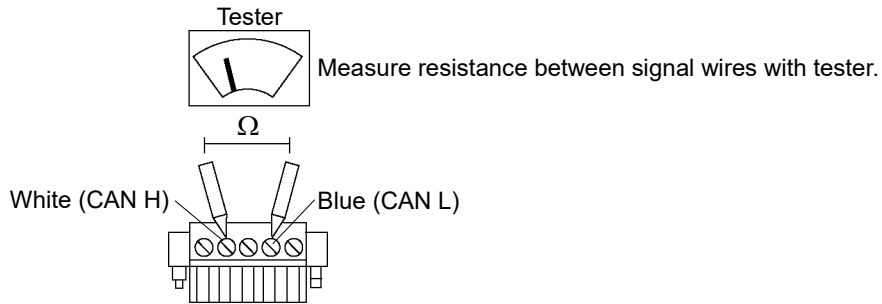

Resistance	Determination
0 Ω	Short circuit
Under 50 Ω	Three or more terminating resistors on one network
50 to 70 Ω	Normal
70 to 120 Ω	Error (cable disconnection or disconnected signal wire on the trunk line)
Over 120 Ω	Error (cable disconnection or disconnected signal wire on drop line or trunk line → Both CAN_H and CAN_L)

4. How to find the trouble point:
 - Remove the terminating resistor on one end of the network.
(The resistance at the point where the terminating resistor is connected is 120 Ω .)
 - Measure resistance at branch taps of all units.
 - The trouble point is where resistance changes from 120 Ω .
 - After finding the trouble point, verify the connector and cable conditions.

◆ Process Flowchart

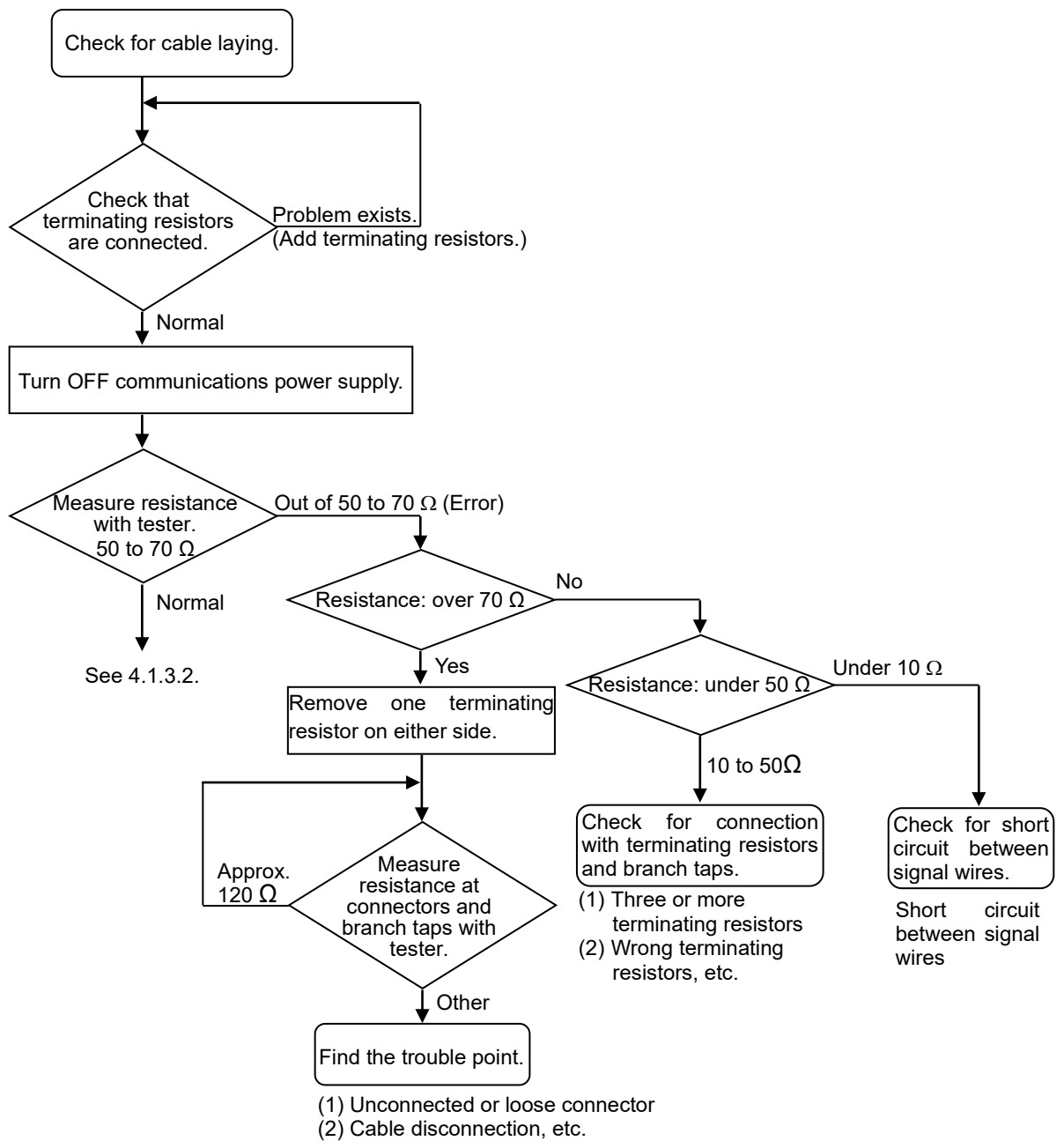

4.1.3.2 Loose Connector and Signal Wire

Check for the connections of the following parts on the connector and cable.

1. Crimping Terminal

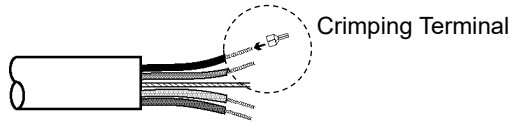

2. Connection of the connector and the signal wire

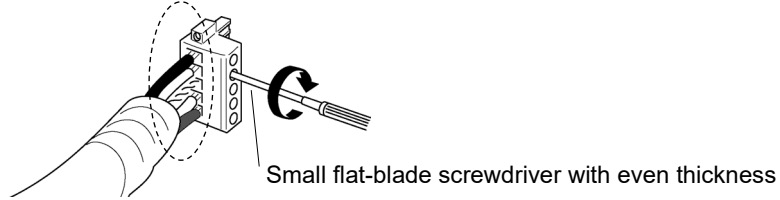

3. Connection of the connector and the unit (T-branch tap)

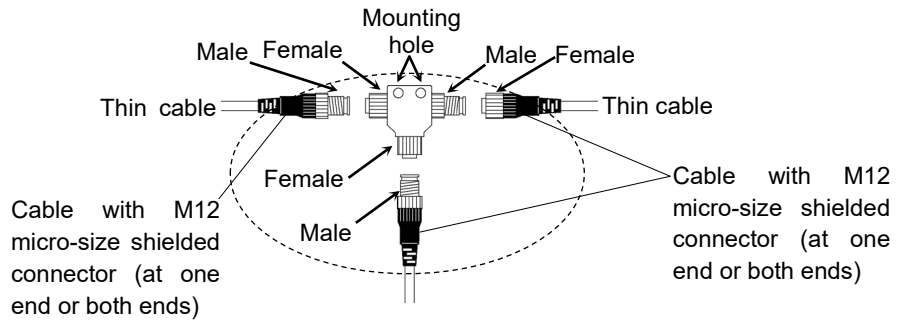
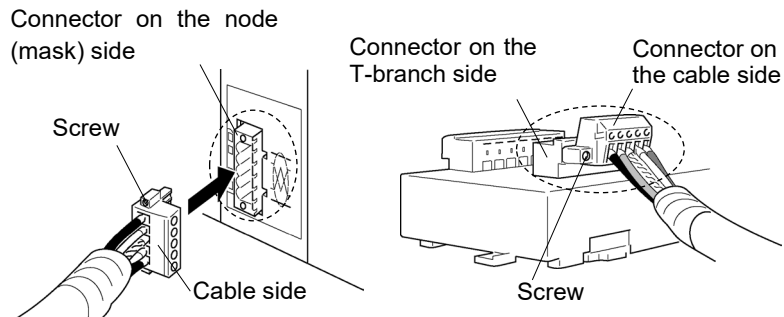

4.1.3.3 Noise Intrusion

Verify how an error occurrence condition changes while taking the following countermeasures.

◆ Ground of FG (DRAIN) wire

Normal Grounding: Ground the DeviceNet network at only one point.

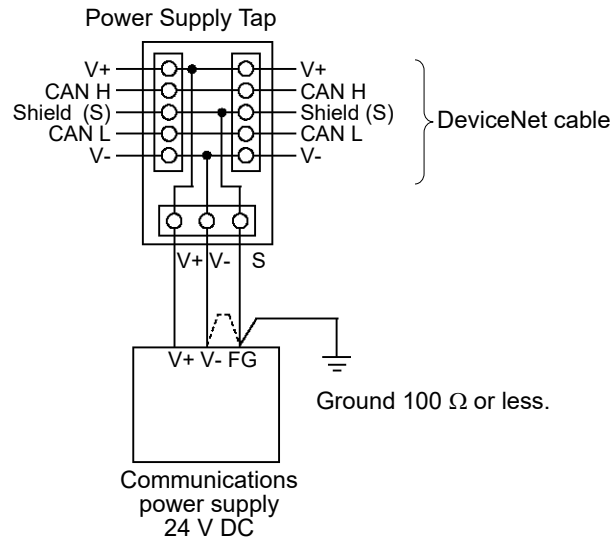

Countermeasure 1: Disconnect the wire between V- and FG.

Disconnect the wire between V- and FG when you cannot ground the FG wire.

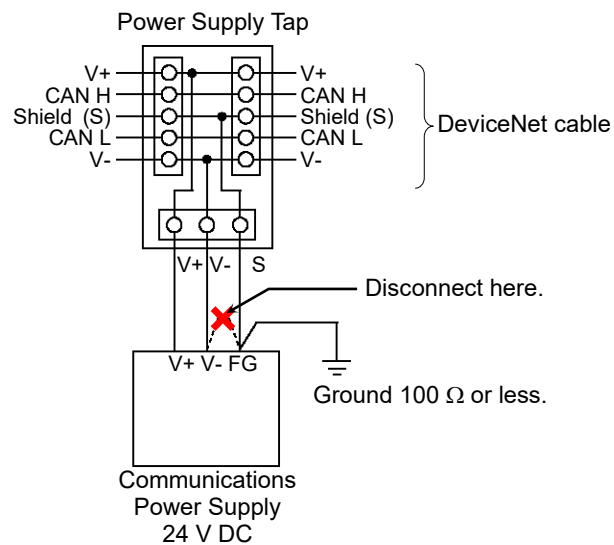

Countermeasure 2: Disconnect the shield wire to isolate it from the ground.

When noise intrudes the ground line due to a noise source such as an inverter installed near the communications power supply, disconnect the shield wire of the communication cable and isolate it from the ground to restrain noise intrusion.

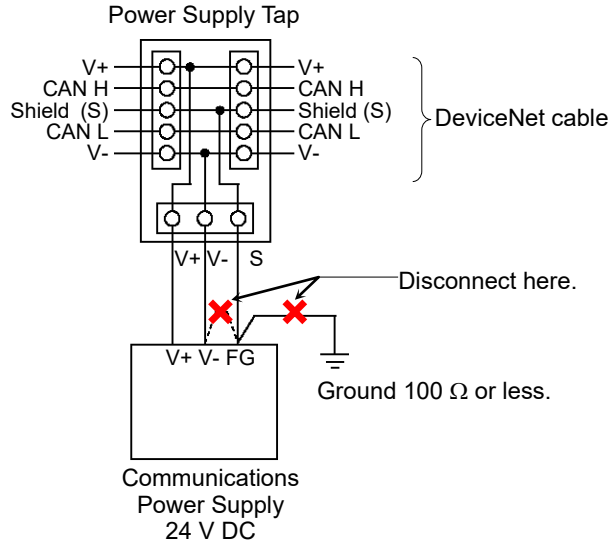

◆ Induced noise via communication cable

Separate the DeviceNet signal wire from the other wires (especially power wires).

* Separate the signal wire from the power wires 300 mm or more.

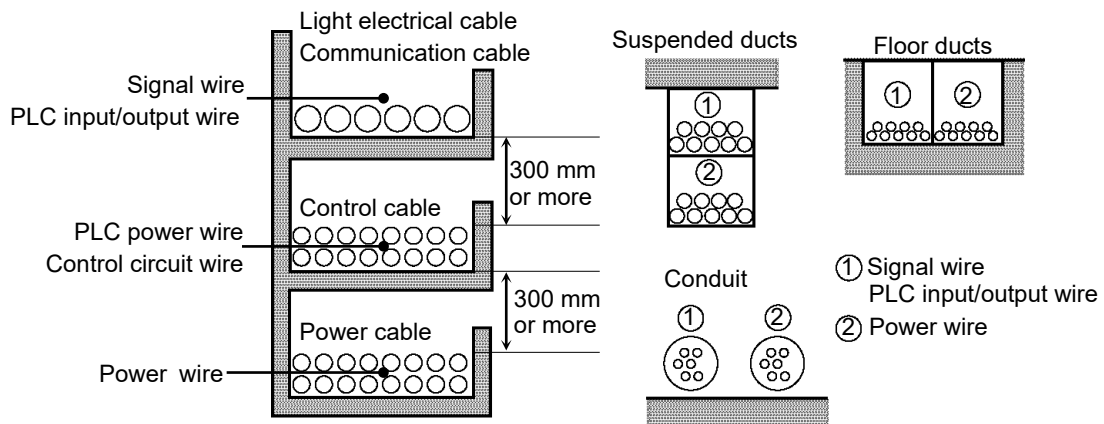

During site inspection, bypass the wire that is possibly affected by induced noise with other cables and then lay the cables. Establish the communication under no induced noise condition and verify whether an error occurs.

◆ Communications Power Supply

When sharing the communications power supply with I/O devices, provide power sources separately.

Separating power source prevents noise caused by I/O device operations from affecting communication.

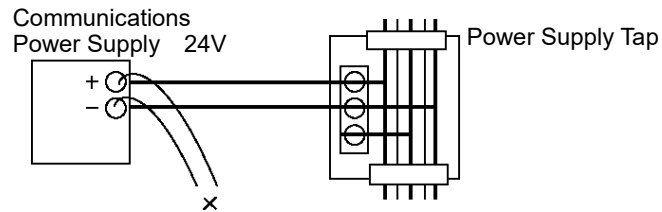

Disconnect I/O devices from the communications power supply.

4.1.3.4 Broken Unit Examination (Dividing Network Examination)

When you cannot quickly find the trouble point due to a broken unit, connection failure including loose connector, or cable partial disconnection, divide the network to find the trouble point. Verify how error occurrence conditions change while taking the following countermeasures.

How to Examine

Divide the network to find which node is the cause of the problem.

Verify that a master can establish communications with the slaves even though one slave is separated from the network.

After finding the problem node, check the cables connected to it and replace the unit.

How to Divide

To divide the network, follow either procedure described below depending on the cable layout.

1. Separating each block from the network

Divide the network by block and check each block.

1. Ensure that the master has no problem by connecting it to its slaves one by one.
(MS/NS: green light ON)
2. Divide the network in the middle of it and check for the communication condition. (MS/NS: green light ON)

Normal: The trouble point is on the other half of the network.

Error: The trouble point is on the current half of the network.

(Continue dividing the network further to distinguish error part from normal part.)

3. Check for communication on the block to specify the trouble point.

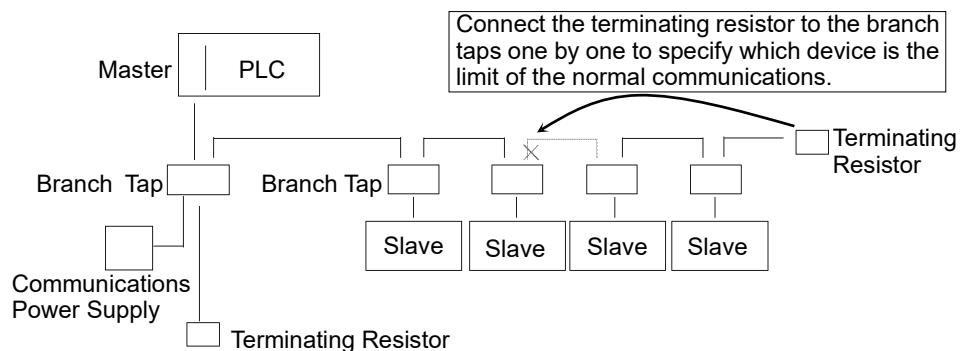

2. Separate each slave from the network
 Check for each slave. The trouble point is where error condition changes into normal condition.

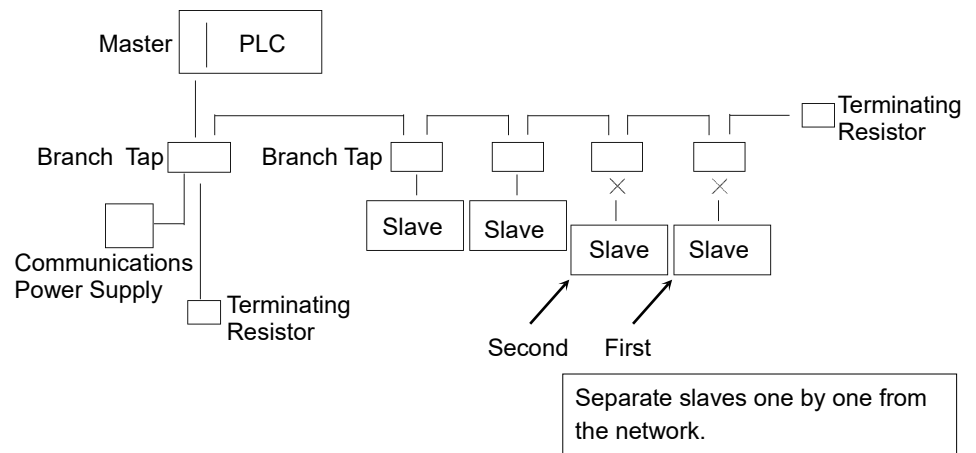

4.1.3.5 Network Configuration and Specifications

1. Maximum Network Length and Drop Line Length
 Check that the cables used on the network meet the following specifications.

Type	Baud Rate	Max. Network Length	Drop Line Length	Total Drop Line Length
Thick Cable	500 kbps	100 m	6 m	39 m
	250 kbps	250 m		78 m
	125 kbps	500 m		156 m
Thin Cable	500 kbps	100 m		39 m
	250 kbps	100 m		78 m
	125 kbps	100 m		156 m

2. Terminating Resistor
 Ensure that two terminating resistors are connected to both ends of the network (trunk line). The terminating resistor should be 121 Ω 1/4 W.
3. Cable and Branch Tap
 The cables and branch taps should meet the DeviceNet specifications.
4. Communications Power Supply

The communications power supply should be dedicated to DeviceNet. Do not share the communications power supply with I/O devices. *

* Noise due to load on/off may affect DeviceNet communications via the communications power supply.
 (The noise causes remote I/O communication error, Busoff detection, and broken unit.)

4.1.3.6 Epson RC+ Master Configuration

For details of Epson RC+ master configuration, refer to the section 2.1.3 *Installing DeviceNet Master Board manufactured by molex.*

The following section describes the procedure for verifying the scanner board condition with applicomIO Console application.

Verifying applicomIO Console application condition

The status bar at the bottom of the window shows the applicomIO Console application status. The status bar varies as shown below:

Character : The address number of the scanner board is indicated with characters. When the character “F” appears, the flash memory on the board initialized the scanner board.

Background color : The background color indicates the scanner board status. For details, refer to the table below.

Background	Character	Status
Gray	Black	Access to scanner board was failed. After that, the status bar will not be renewed automatically. To renew the status bar, right-click the status bar and select Refresh.
Magenta	Black	The scanner board was initialized with an earlier version applicomIO Console application. It is recommended that the scanner board be written into the flash memory (reinitializing the scanner board) again with the current version applicomIO Console application.
Red	Black	The scanner board was not initialized. Initialize the scanner board to use it.
Yellow	Black	The scanner board was partially initialized. This status happens only during network detection and on-line actions.
Dark green	White	Although the scanner board was initialized, it is different than the currently opened configuration. (Different version, etc.) It is recommended that the scanner board be written into the flash memory (reinitializing the scanner board) again with the current version applicomIO Console application. This status happens only during network detection, on-line actions, and diagnostic.
Green	Black	The scanner board was initialized properly and it is no different with the currently opened configuration. This status happens only during network detection, on-line actions, and diagnostics.

Verifying the DeviceNet network condition

The applicomIO Console application has a network diagnostic function (Diagnostic). The procedure for using the Diagnostic is described below.

1. Open the Diagnostic window, click the magnifying glass icon, and select the “Channel” on the device tree in the left side of the window.

The window changes as shown below.

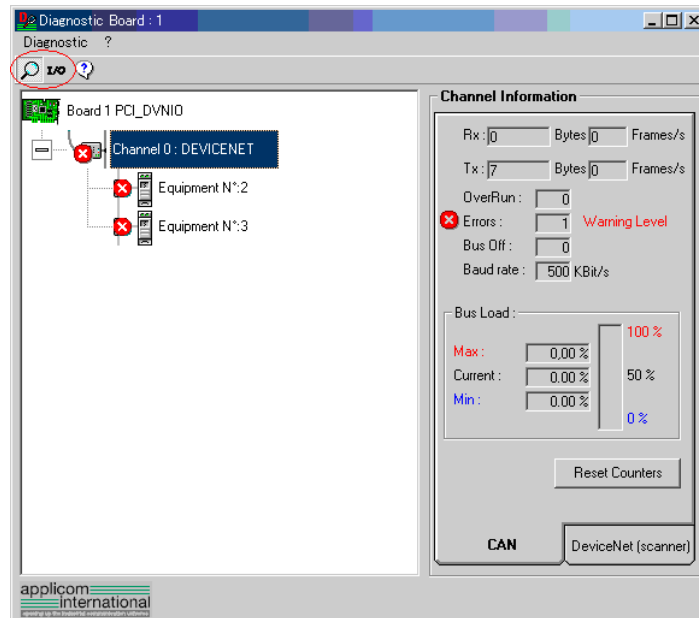

The [CAN] and [DeviceNet (scanner)] tabs appear on the data display in the right side of the window.

The [CAN] Controller status of the scanner board is displayed on the CAN Controller.

Rx : Number of receive data bytes and frames

Tx : Number of send data bytes and frames

OverRun : Number of communication overrun errors detected by CAN Controller

Errors : Number of communication errors detected by CAN Controller

Bus Off : Number of Busoff detections

Baud Rate : Baud rate

Bus Load : Load on the bus (maximum, minimum, current)

NOTE



Use DeviceNet so that the load on a bus is under 60% of the maximum load. When the load exceeds 60%, the DeviceNet network communication will be unstable. (For example, more communication errors)

For the procedure for master configuration, refer to respective master device manuals. For Epson RC+ master configuration, refer to the section 2.1.3 *Installing DeviceNet Master Board manufactured by molex.*

4. Troubleshooting (DeviceNet)

- Select the [DeviceNet (scanner)] tab. The window changes as shown below.

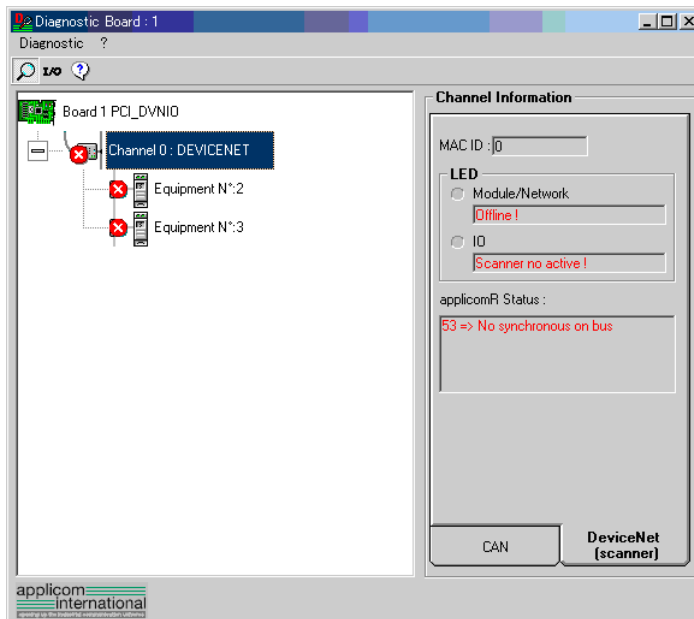

MAC ID : MAC ID specified for the scanner board
 Module/NetWork LED : Network Status (NS) LED status
 IO LED : Module Status (MS) LED status
 applicomR Status : Scanner board status

The scanner board status is shown in the “Code No. => Comment” form. The table below shows the code numbers.

Status Code		Descriptions
General	Protocol	
0		No fault detected. The function was performed correctly.
	4	Inaccessible data. Additional information: The remote device is in error. Check its status.
32		The parameters passed to the functions are not correct (eg: Number of requested variables too large)
	33	Response time-out error. Additional information: The device does not respond. Check the device status and the wiring. The DeviceNet master has no device to be scanned in the configuration.
	34	Physical defect on the line. Additional information: No +24V power supply was detected. The CAN component of the applicomIO® interface is "Bus Off". Check the network wiring and Baud Rate.
36		Device not configured. Define the device configuration with the applicomIO® Console and re-initiate the initialization of the applicomIO® product by running the PCInitIO

Status Code		Descriptions
General	Protocol	
45		Non-resident dialogue software. Additional information: Initialize the applicomIO® interface before use by running the PCInitIO
47		Targeted applicomIO® card invalid or incorrectly initialized by the function IO_Init
	53	Synchronization problem on the line. Additional information: The DeviceNet master is “off line” (power supply not detected or the CAN component of the applicomIO® is “Bus Off”) Check the network wiring and Baud Rate.
	55	Response time-out exceeded. Additional information: The device accepted the connection but did not respond the request. Check the device status.
	65	Connection denied. Additional information: Connection to the DeviceNet master is in progress or refused by the device.
	70	Connection finished. Additional information: Duplication of MAC ID detected on the DeviceNet network. Modify the MAC ID of the DeviceNet master.
	79	Profile incompatible. Additional information: The device does not match the configuration. Check the device identity and the connection sizes.
63		Indicates that a communication error has been encountered on serial Port.
66		Not enough applicomIO® interface memory.
93		Driver cannot be accessed.
99		Indicates that applicomIO® solution is already running.
255		Indicates that the local input buffer was not updated beforehand by the function IO_RefreshInput.

4. Troubleshooting (DeviceNet)

- When you click [I/O] icon on the upper left of the window, the window changes as shown below.

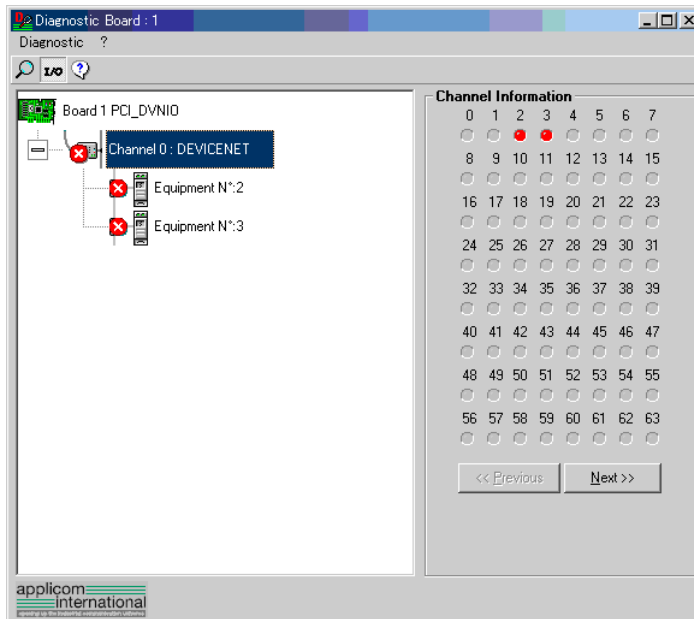

Each slave device status is shown in the right side of the window.

A green circle indicates that the communication of the corresponding device is normal, and a red circle indicates that there is a communication error.

A gray circle indicates that the corresponding device does not exist.

- When you select [Equipment] on the device tree in the left side of the window, the window changes as shown below.

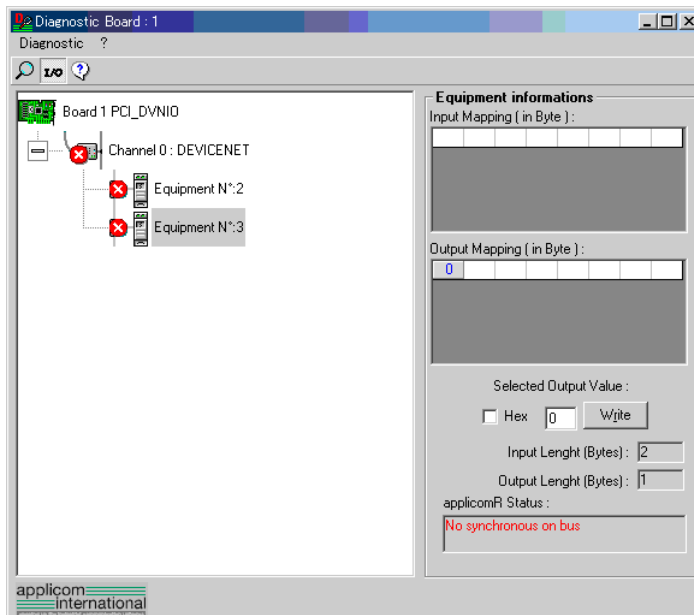

The input and output statuses of the selected device are shown in the right side of the window.

If you want to change output data, click the byte number you want to change in [Output Mapping]. Then, enter a value in [Selected Output Value:]-[Write] and click the [Write] button.

4.2 PROFIBUS DP Troubleshooting

Exclusion

Every system has its special environment, conditions, specifications, and usages. This guide is provided as a general reference for troubleshooting a PROFIBUS DP network. Every effort has been made to ensure the information is accurate. However, we do not guarantee the complete accuracy of the information and thus we decline any liability for damages or costs incurred by the use of this troubleshooting.

Before examining a problem on the network, please ensure that your established PROFIBUS DP system satisfies network specifications. (Refer to this troubleshooting and the section 2.2.2 *PROFIBUS DP Network Construction*.)

Tools

Prepare the following tools for troubleshooting.

- Philips screwdriver
- Flat-blade screwdriver
- Tester

4.2.1 Examining a Problem

4.2.1.1 Scanner Board Diagnostic LEDs

The PROFIBUS DP board used with Epson RC+ has two status display LEDs. The layout of the LEDs is shown in the following figure.

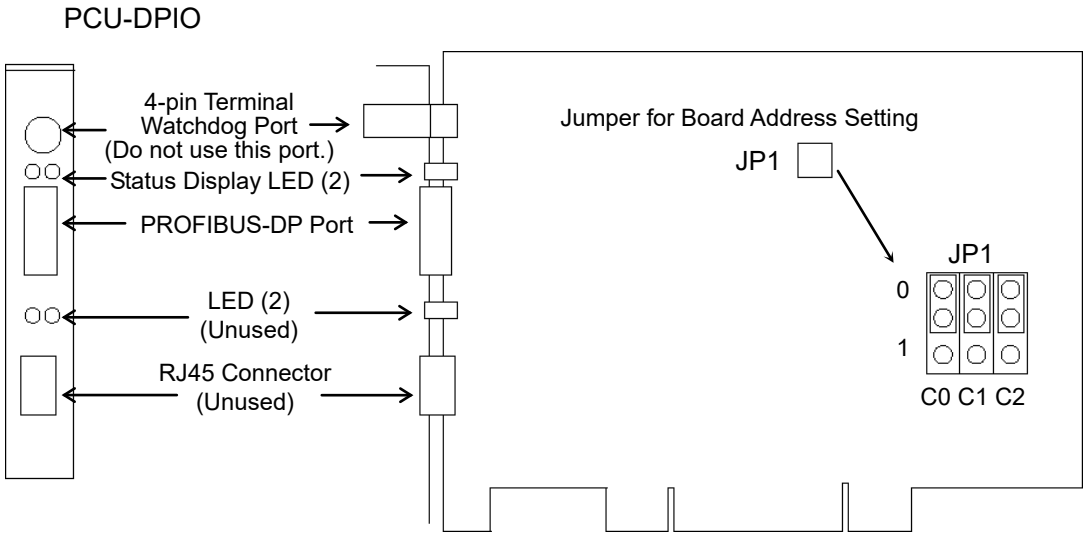

The Communication Status LED is on the left and the Physical Error LED is on the right seen from the rear panel.

The Communication Status LED is referred to as the ST LED (ST) in this section.

The Physical Error LED is referred to as the BF LED (BF) in this section.

4.2.1.2 Check Network Status

As a first step, check the current condition of the network. There are different specifications of status display LED on a device in the PROFIBUS DP standard. This section explains how to check the network status assuming that Epson RC+ is configured as a master or slave.

1. Master Status: BF/ST LEDs

LED	Color	Light Condition
BF (Physical error)	<input type="checkbox"/> Green <input type="checkbox"/> Red	<input type="checkbox"/> ON <input type="checkbox"/> Blinking <input type="checkbox"/> OFF
ST (Communication Status)	<input type="checkbox"/> Green <input type="checkbox"/> Red	<input type="checkbox"/> ON <input type="checkbox"/> Blinking <input type="checkbox"/> OFF

2. Station Number of Absent Slaves

Absent slaves are disconnected from or not added to the network.

1. See the status flag regarding to the removal and addition if the master has status information.
2. See the BF/ST LEDs of all slaves if the master has no status information.

3. Absent Slave Status: BF/ST LEDs

LED	Color	Light Condition
BF (Physical error)	<input type="checkbox"/> Green <input type="checkbox"/> Red	<input type="checkbox"/> ON <input type="checkbox"/> Blinking <input type="checkbox"/> OFF
ST (Communication Status)	<input type="checkbox"/> Green <input type="checkbox"/> Red	<input type="checkbox"/> ON <input type="checkbox"/> Blinking <input type="checkbox"/> OFF

4. Physical Node Location of Absent Slave

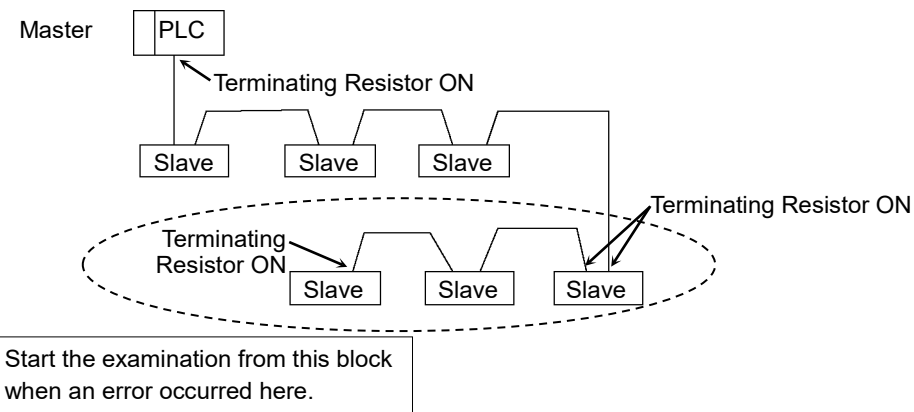

5. Error Occurrence Condition

- Immediate occurrence (high reproducibility)
- Rare occurrence (low reproducibility)

4.2.2 Problems and Countermeasures

Master Unit LED		Error	Description [Reference]
BF	ST		
Light OFF	Green Light Blinking	Normal communication	- Normal condition
Light OFF	Green Light ON	Ready for communication	- Normal condition
Light OFF	Red Light Blinking	Communication error	[Refer to the section 4.2.2.1 <i>Master Communication Error.</i>] - Slave disconnected from the network (Remote I/O communication error) - Slave not added to the network (Scan list collation error) - Nonstandard wiring - No or too many terminating resistors - Noise intrusion
Light OFF	Red Light ON	Data link layer error	[Refer to the section 4.2.2.2 <i>Master: Data Link Layer Error.</i>] - Nonstandard wiring - Noise intrusion
Light OFF	Light OFF	Uninitialized network	[Refer to the section 4.2.2.3 <i>Master: Uninitialized Network.</i>] - Master unit power error - Master unit configuration error
Red Light ON	No Matter	Physical error	[Refer to the section 4.2.2.4 <i>Master: Configuration Error.</i>] - Nonstandard wiring - Signal wire connection failure - Signal wire short circuit

4. Troubleshooting (PROFIBUS DP)

◆ Process Flowchart

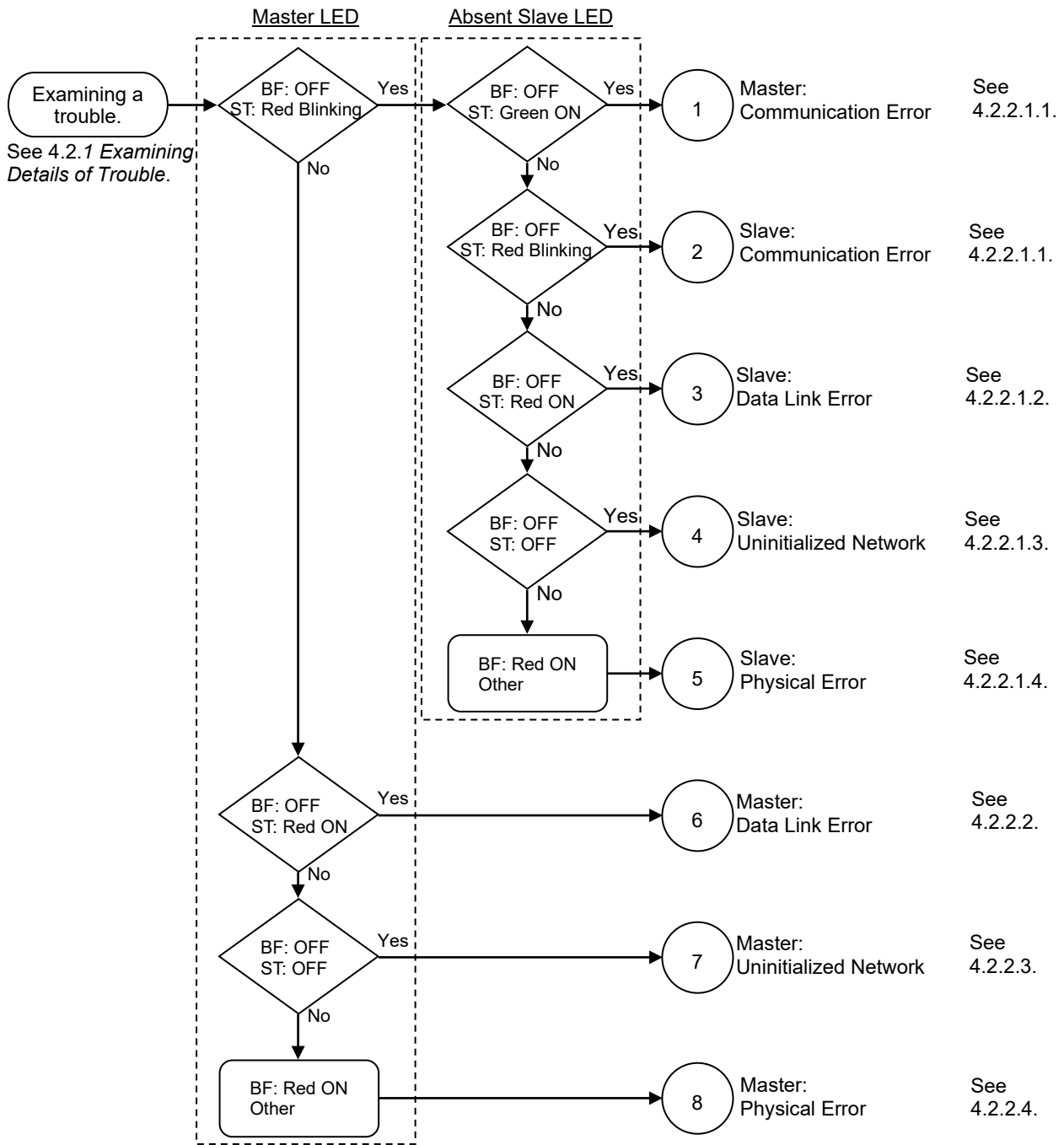

4.2.2.1 Master: Communication Error

Master Unit LED		Error	Description
BF	ST		
Light OFF	Red Light Blinking	Communication error	<ul style="list-style-type: none"> - Slave disconnected from the network (Remote I/O communication error) - Slave not added to the network (Scan list collation error) - Nonstandard wiring - No or too many terminating resistors - Noise intrusion

Master/Slave: Communication Error

	BF	ST
Master LED Condition	Light OFF	Red Light Blinking
Absent Slave LED Condition (Communication error)	Light OFF	Green Light Blinking
	Light OFF	Red Light Blinking

4. Troubleshooting (PROFIBUS DP)

◆ Process Flowchart

Check

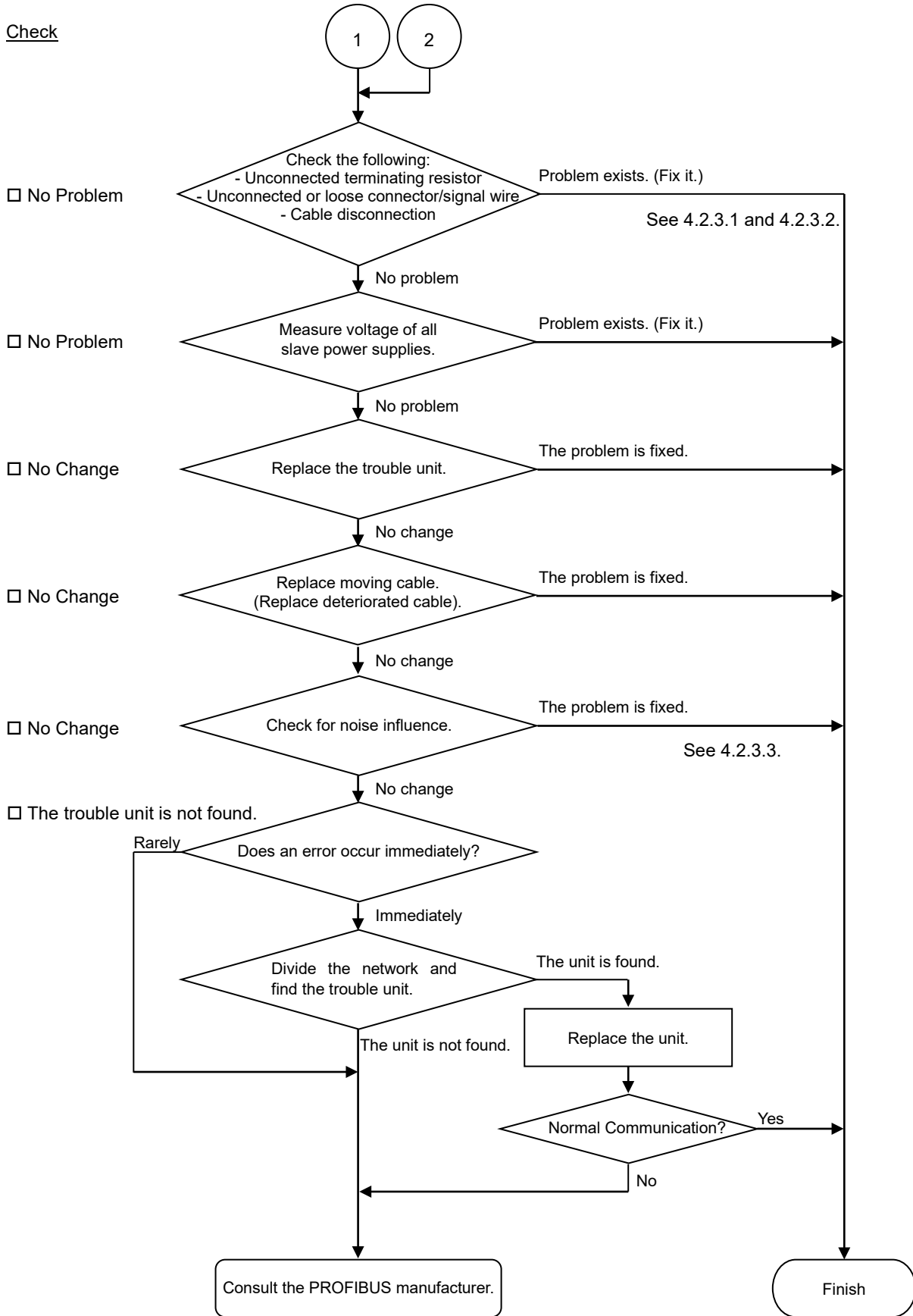

◆ Causes of Error

Possible Cause	Examination Method	Countermeasure
<ul style="list-style-type: none"> ○ Disconnected terminating resistors ○ Cable disconnection ○ Disconnected connector ○ Disconnected signal wire 	<p>(1) Check that terminating resistors are connected to both ends of the network.</p> <p>(2) Measure resistance between signal wires with device power supply OFF.</p> <p>→ Normal: 100 to 120 Ω</p> <ul style="list-style-type: none"> ● Measuring point: Connection of the trouble unit ● For details, refer to the section <i>4.2.3.1 Connection Problem</i>. 	<p>Fix the problem.</p> <p>How to find the trouble point: Remove the terminating resistor on one end of the network. The trouble point is where resistance changes from 220 Ω.</p>
<ul style="list-style-type: none"> ○ Loose connector ○ Loose signal wire 	<p>Check for the connection of connectors and signal wires.</p> <p>→ The connectors and signal wires should be firmly connected.</p> <ul style="list-style-type: none"> ● Checkpoint: all stations and all branch taps ● For details, refer to the section <i>4.2.3.2 Loose Connector and Signal Wire</i>. 	<p>Connect the connectors and signal wires again.</p>
<ul style="list-style-type: none"> ○ Electrical surges of device power supply 	<p>Measure voltage of the device power supply at the trouble unit.</p> <p>→ It should be within the range of sufficient voltage for device operation.</p>	<p>Check voltage of the device power supply.</p>
<ul style="list-style-type: none"> ○ Noise (external cause) 	<p>Check the noise intrusion via the following paths (1) to (3).</p> <p>(1) Noise via shield</p> <p>(2) Induced noise via communication cable</p> <p>(3) Device power supply</p> <p>→ For details, refer to the section <i>4.2.3.3 Noise Intrusion</i>.</p>	<p>Take countermeasures against noise.</p>
<ul style="list-style-type: none"> ○ Broken unit 	<p>Replace the trouble unit with a new one.</p> <p>→ Verify whether the problem is fixed.</p>	<p>Replace the unit with a new one.</p>
<ul style="list-style-type: none"> ● No cause is identified. 	<p>Identify the trouble point by dividing the network.</p> <p>→ For details, refer to the section <i>4.2.3.4 Broken Unit Examination</i>.</p>	

4. Troubleshooting (PROFIBUS DP)

Slave: Data Link Error

	MS	NS
Master LED Condition	Light OFF	Red Light Blinking
Absent Slave LED Condition (Data link error)	Light OFF	Red Light ON

◆ Process Flowchart

Check

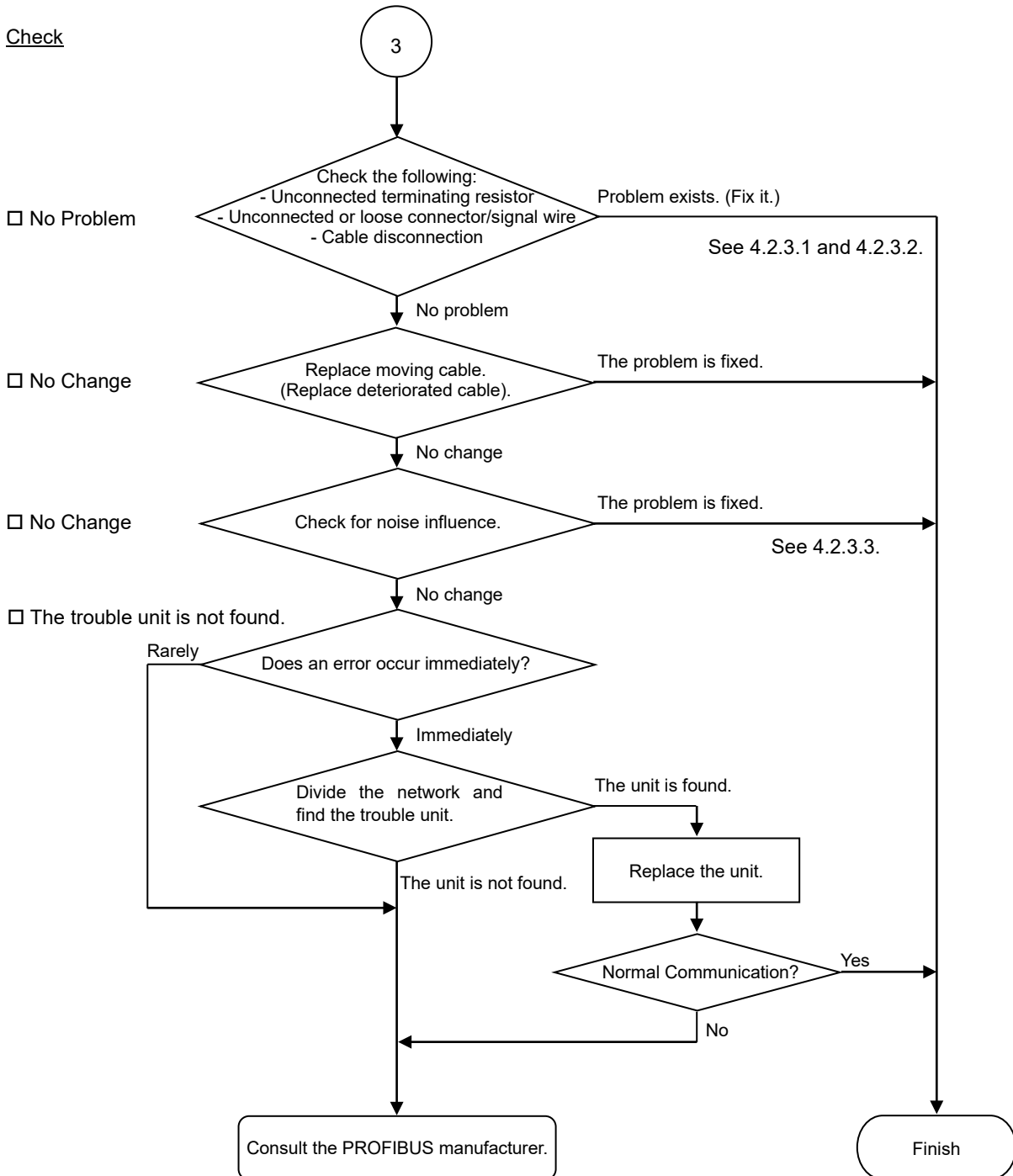

◆ Causes of Error

Possible Cause	Examination Method	Countermeasure
<ul style="list-style-type: none"> ○ Disconnected terminating resistors ○ Cable disconnection ○ Disconnected connector ○ Disconnected signal wire 	<p>(1) Check that terminating resistors are connected to both ends of the network.</p> <p>(2) Measure resistance between signal wires with device power supply OFF.</p> <p>→ Normal: 100 to 120 Ω</p> <ul style="list-style-type: none"> ● Measuring point: Connection of the trouble unit ● For details, refer to the section <i>4.2.3.1 Connection Problem.</i> 	<p>Fix the problem.</p> <p>How to find the trouble point: Remove the terminating resistor on one end of the network. The trouble point is where resistance changes from 220 Ω.</p>
<ul style="list-style-type: none"> ○ Loose connector ○ Loose signal wire 	<p>Check for the connection of connectors and signal wires.</p> <p>→ The connectors and signal wires should be firmly connected.</p> <ul style="list-style-type: none"> ● Checkpoint: all stations and all branch taps ● For details, refer to the section <i>4.2.3.2 Loose Connector and Signal Wire.</i> 	<p>Connect the connectors and signal wires again.</p>
<ul style="list-style-type: none"> ○ Noise (external cause) 	<p>Check the noise intrusion via the following paths (1) to (3).</p> <p>(1) Noise via shield</p> <p>(2) Induced noise via communication cable</p> <p>(3) Device power supply</p> <p>→ For details, refer to the section <i>4.2.3.3 Noise Intrusion.</i></p>	<p>Take countermeasures against noise.</p>
<ul style="list-style-type: none"> ○ Broken unit 	<p>Replace the trouble unit with a new one.</p> <p>→ Verify whether the problem is fixed.</p>	<p>Replace the unit with a new one.</p>
<ul style="list-style-type: none"> ● No cause is identified. 	<p>Identify the trouble point by dividing the network.</p> <p>→ For details, refer to the section <i>4.2.3.4 Broken Unit Examination.</i></p>	

Slave: Uninitialized Network

	BF	ST
Master LED Condition	Light OFF	Red Light Blinking
Absent Slave LED Condition (Uninitialized Network)	Light OFF	Light OFF

◆ Process Flowchart

Check

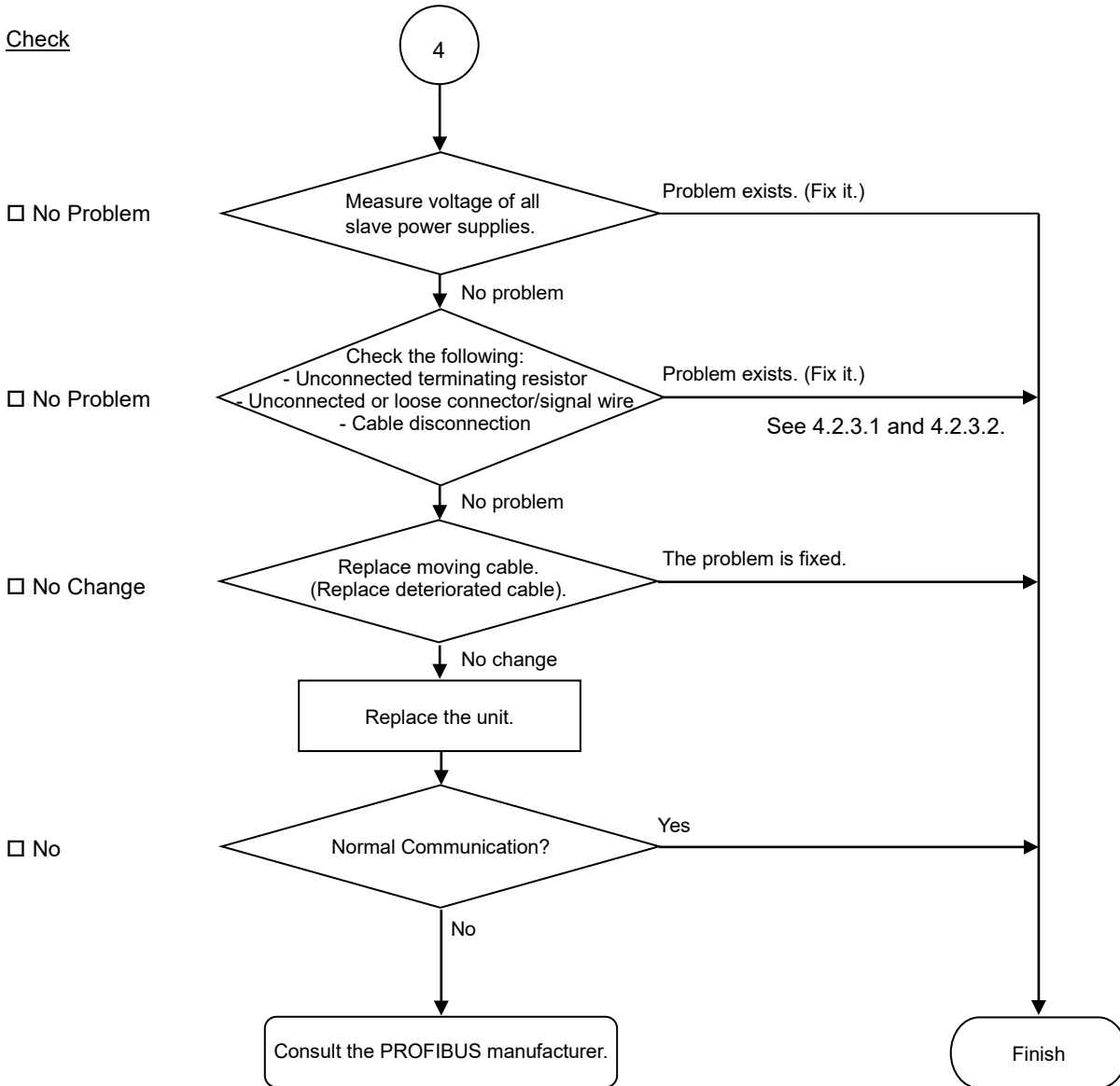

◆ Causes of Error

Possible Cause	Examination Method	Countermeasure
○ Electrical surges of device power supply	Measure voltage of the device power supply at the trouble unit. → It should be within the range of sufficient voltage for device operation.	Check voltage of the device power supply.
○ Disconnected terminating resistors ○ Cable disconnection ○ Disconnected connector ○ Disconnected signal wire	(1) Check that terminating resistors are connected to both ends of the network. (2) Measure resistance between signal wires with device power supply OFF. → Normal: 100 to 120 Ω ● Measuring point: Connection of the trouble unit ● For details, refer to the section <i>4.2.3.1 Connection Problem</i> .	Fix the problem. How to find the trouble point: Remove the terminating resistor on one end of the network. The trouble point is where resistance changes from 220 Ω.
○ Loose connector ○ Loose signal wire	Check for the connection of connectors and signal wires. → The connectors and signal wires should be firmly connected. ● Checkpoint: all stations and all branch taps ● For details, refer to the section <i>4.2.3.2 Loose Connector and Signal Wire</i> .	Connect the connectors and signal wires again.
○ Broken unit	Replace the trouble unit with a new one. → Verify whether the problem is fixed.	Replace the unit with a new one.

4. Troubleshooting (PROFIBUS DP)

Physical Error

	BF	ST
Master LED Condition	Light OFF	Red Light Blinking
Absent Slave LED Condition (Physical error)	Red Light ON	No Matter

◆ Process Flowchart

Check

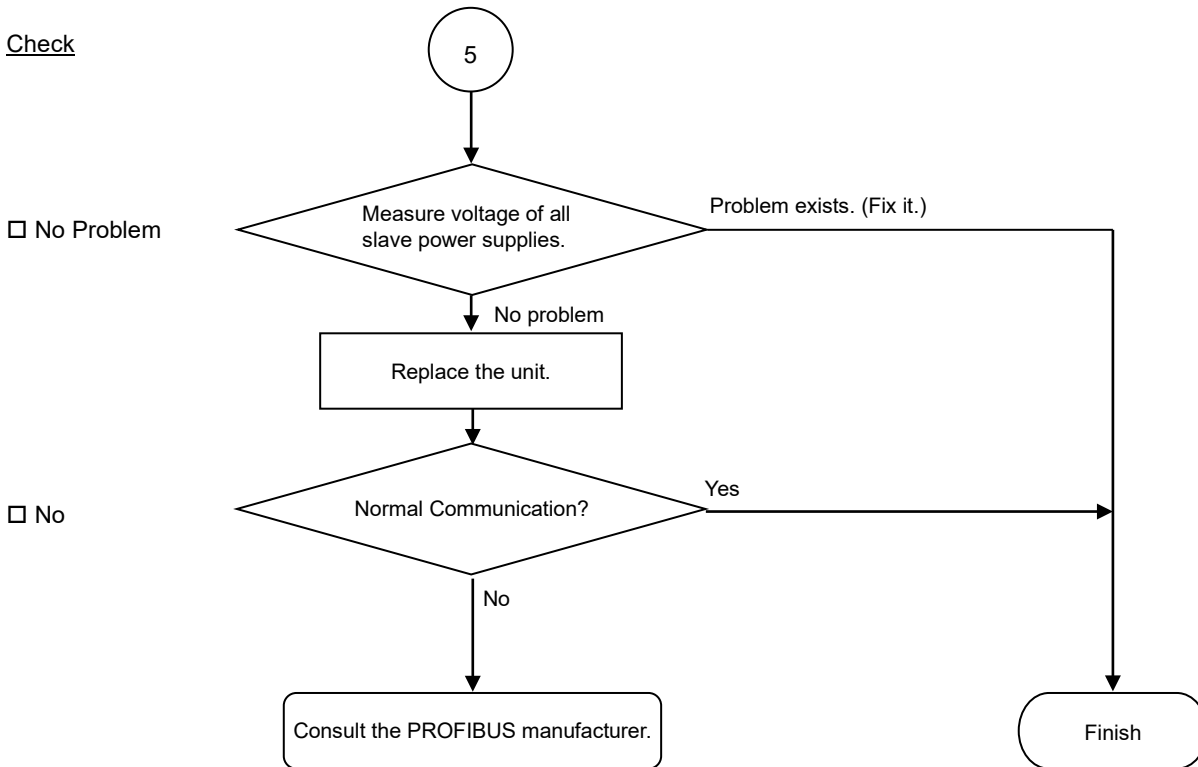

◆ Causes of Error

Possible Cause	Examination Method	Countermeasure
○ Electrical surges of device power supply	Measure voltage of the device power supply at the trouble unit. →It should be within the range of sufficient voltage for device operation.	Check voltage of the device power supply.
○ Broken unit	Replace the trouble unit with a new one. →Verify whether the problem is fixed.	Replace the unit with a new one.

4.2.2.2 Master: Data Link Layer Error

Master Unit LED		Error	Description
BF	ST		
Light OFF	Red Light ON	Data link layer error	- Nonstandard wiring - Noise intrusion

◆ Process Flowchart

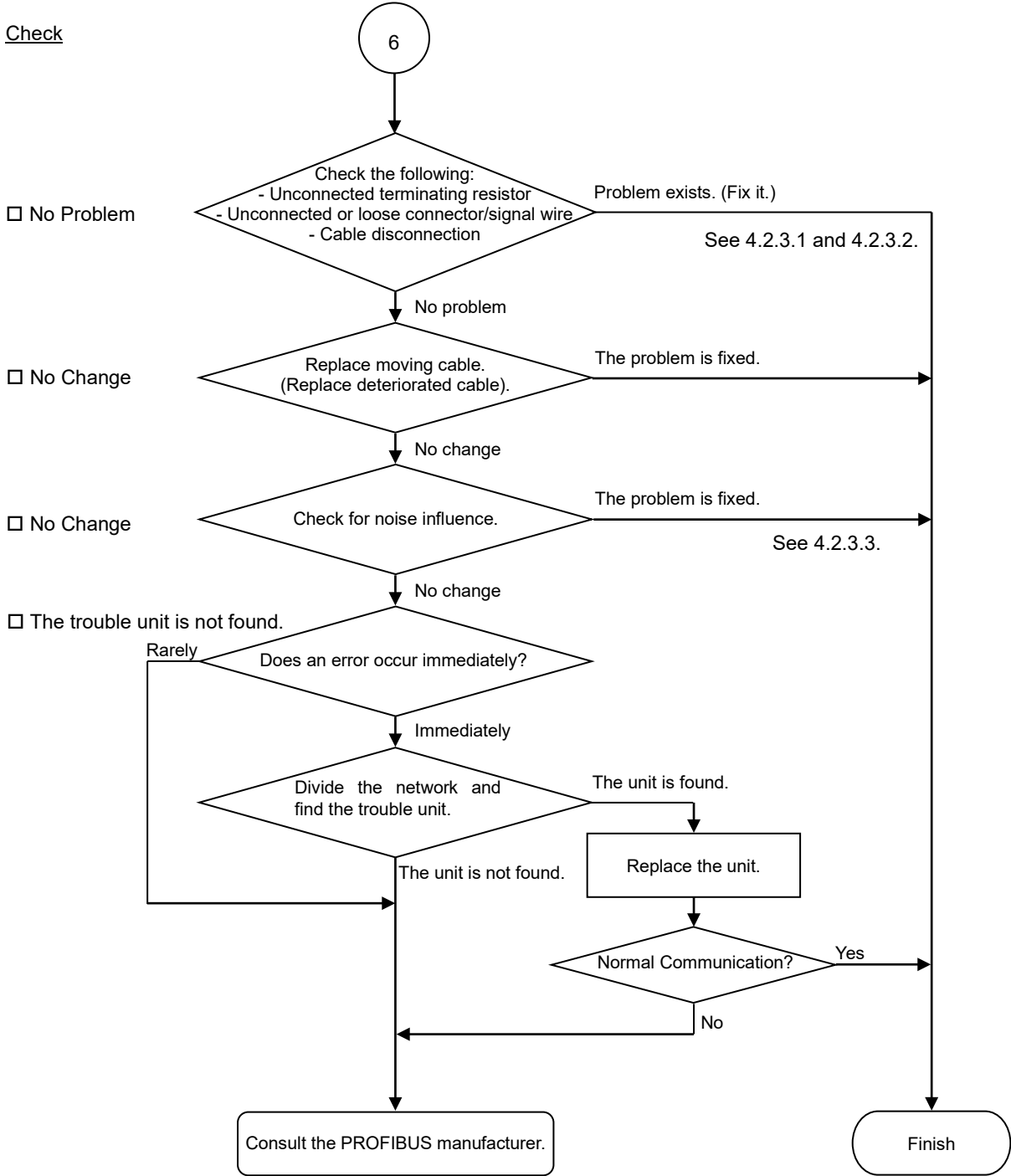

◆ Causes of Error

Possible Cause	Examination Method	Countermeasure
<ul style="list-style-type: none"> ○ Disconnected terminating resistors ○ Cable disconnection ○ Disconnected connector ○ Disconnected signal wire 	<p>(1) Check that terminating resistors are connected to both ends of the network.</p> <p>(2) Measure resistance between signal wires with device power supply OFF.</p> <p>→ Normal: 100 to 120 Ω</p> <ul style="list-style-type: none"> ● Measuring point: Connection of the trouble unit ● For details, refer to the section <i>4.2.3.1 Connection Problem.</i> 	<p>Fix the problem.</p> <p>How to find the trouble point: Remove the terminating resistor on one end of the network. The trouble point is where resistance changes from 220 Ω.</p>
<ul style="list-style-type: none"> ○ Loose connector ○ Loose signal wire 	<p>Check for the connection of connectors and signal wires.</p> <p>→The connectors and signal wires should be firmly connected.</p> <ul style="list-style-type: none"> ● Checkpoint: all stations and all branch taps ● For details, refer to the section <i>4.2.3.2 Loose Connector and Signal Wire.</i> 	<p>Connect the connectors and signal wires again.</p>
<ul style="list-style-type: none"> ○ Noise (external cause) 	<p>Check the noise intrusion via the following paths (1) to (3).</p> <p>(1) Noise via shield</p> <p>(2) Induced noise via communication cable</p> <p>(3) Device power supply</p> <p>→For details, refer to the section <i>4.2.3.3 Noise Intrusion.</i></p>	<p>Take countermeasures against noise.</p>
<ul style="list-style-type: none"> ○ Broken unit 	<p>Replace the trouble unit with a new one.</p> <p>→Verify whether the problem is fixed.</p>	<p>Replace the unit with a new one.</p>
<ul style="list-style-type: none"> ● No cause is identified. 	<p>Identify the trouble point by dividing the network.</p> <p>→For details, refer to the section <i>4.2.3.4 Broken Unit Examination.</i></p>	

4.2.2.3 Master: Uninitialized Network

Master Unit LED		Error	Description
BF	ST		
Light OFF	Light OFF	Uninitialized network	- Master unit power error - Master unit configuration error

◆ Process Flowchart

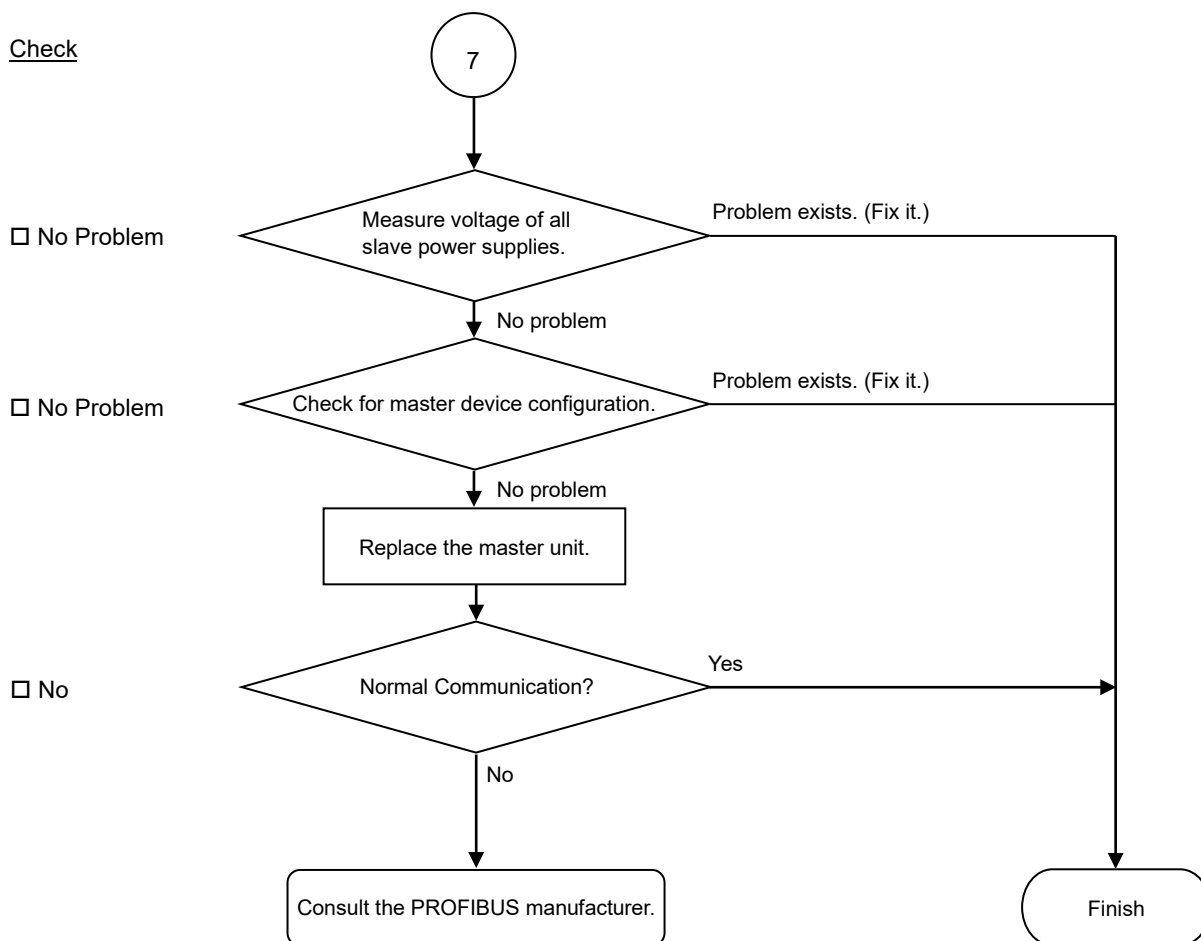

◆ Causes of Error

Possible Cause	Examination Method	Countermeasure
○ Electrical surges of master device power supply	Measure voltage of the device power supply at the master unit. →It should be within the range of sufficient voltage for device operation.	Check voltage of the device power supply.
○ Master device configuration error	Check that the master device was configured properly. →After changing the configuration, verify whether the problem is fixed.	Check the master unit configuration.
○ Broken master unit	Replace the broken master unit with a new one. →Verify whether the problem is fixed.	Replace the master unit with a new one.

4.2.2.4 Master: Configuration Error

Master Unit LED		Error	Description
BF	ST		
Red Light ON	No Matter	Physical error	- Nonstandard wiring - Signal wire connection failure - Signal wire short circuit

◆ Process Flowchart

Check

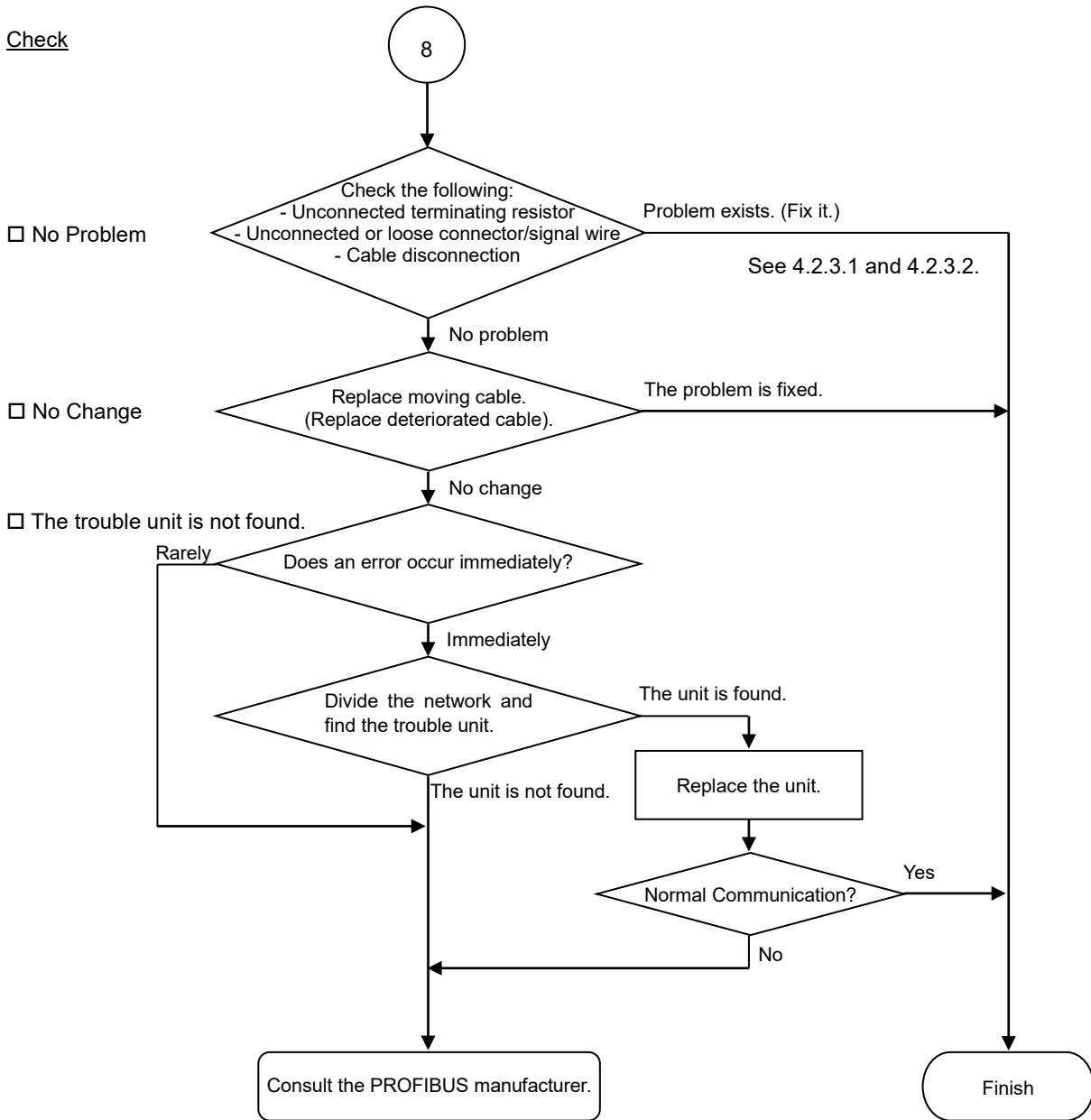

◆ Causes of Error

Possible Cause	Examination Method	Countermeasure
<ul style="list-style-type: none"> ○ Disconnected terminating resistors ○ Cable disconnection ○ Disconnected connector ○ Disconnected signal wire 	<p>(1) Check that terminating resistors are connected to both ends of the network.</p> <p>(2) Measure resistance between signal wires with device power supply OFF.</p> <p>→ Normal: 100 to 120 Ω</p> <ul style="list-style-type: none"> ● Measuring point: Connection of the trouble unit ● For details, refer to the section <i>4.2.3.1 Connection Problem</i>. 	<p>Fix the problem.</p> <p>How to find the trouble point: Remove the terminating resistor on one end of the network. The trouble point is where resistance changes from 220 Ω.</p>
<ul style="list-style-type: none"> ○ Loose connector ○ Loose signal wire 	<p>Check for the connection of connectors and signal wires.</p> <p>→The connectors and signal wires should be firmly connected.</p> <ul style="list-style-type: none"> ● Checkpoint: all stations and all branch taps ● For details, refer to the section <i>4.2.3.2 Loose Connector and Signal Wire</i>. 	<p>Connect the connectors and signal wires again.</p>
<ul style="list-style-type: none"> ○ Broken unit 	<p>Replace the trouble unit with a new one.</p> <p>→Verify whether the problem is fixed.</p>	<p>Replace the unit with a new one.</p>
<ul style="list-style-type: none"> ● No cause is identified. 	<p>Identify the trouble point by dividing the network.</p> <p>→ For details, refer to the section <i>4.2.3.4 Broken Unit Examination</i>.</p>	

4.2.3 Procedures for Examining Possible Causes

4.2.3.1 Connection Problem (Disconnected Terminating Resistors, Cable Disconnection, Disconnected Connector, and Disconnected Signal Wire)

1. Ensure that two terminating resistors are connected to both ends of the network.
2. Turn OFF all device power supplies.
3. Measure resistance between A1 and B1 wires of the absent slave using the tester.

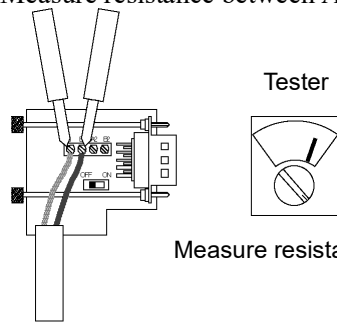

Measure resistance between signal wires with tester.

Resistance	Determination
0 Ω	Short circuit
Under 100 Ω	Three or more terminating resistors on one network
100 to 120 Ω	Normal
Over 120 Ω	Error (cable disconnection, disconnected signal wire, one or zero terminating resistor)

4. How to find the trouble point:
 - Remove the terminating resistor on one end of the network.
(The resistance at the point where the terminating resistor is connected is 220 Ω.)
 - Measure resistance at branch taps of all units.
 - The trouble point is where resistance changes from 220 Ω.
 - After finding the trouble point, verify the connector and cable conditions.

◆ Process Flowchart

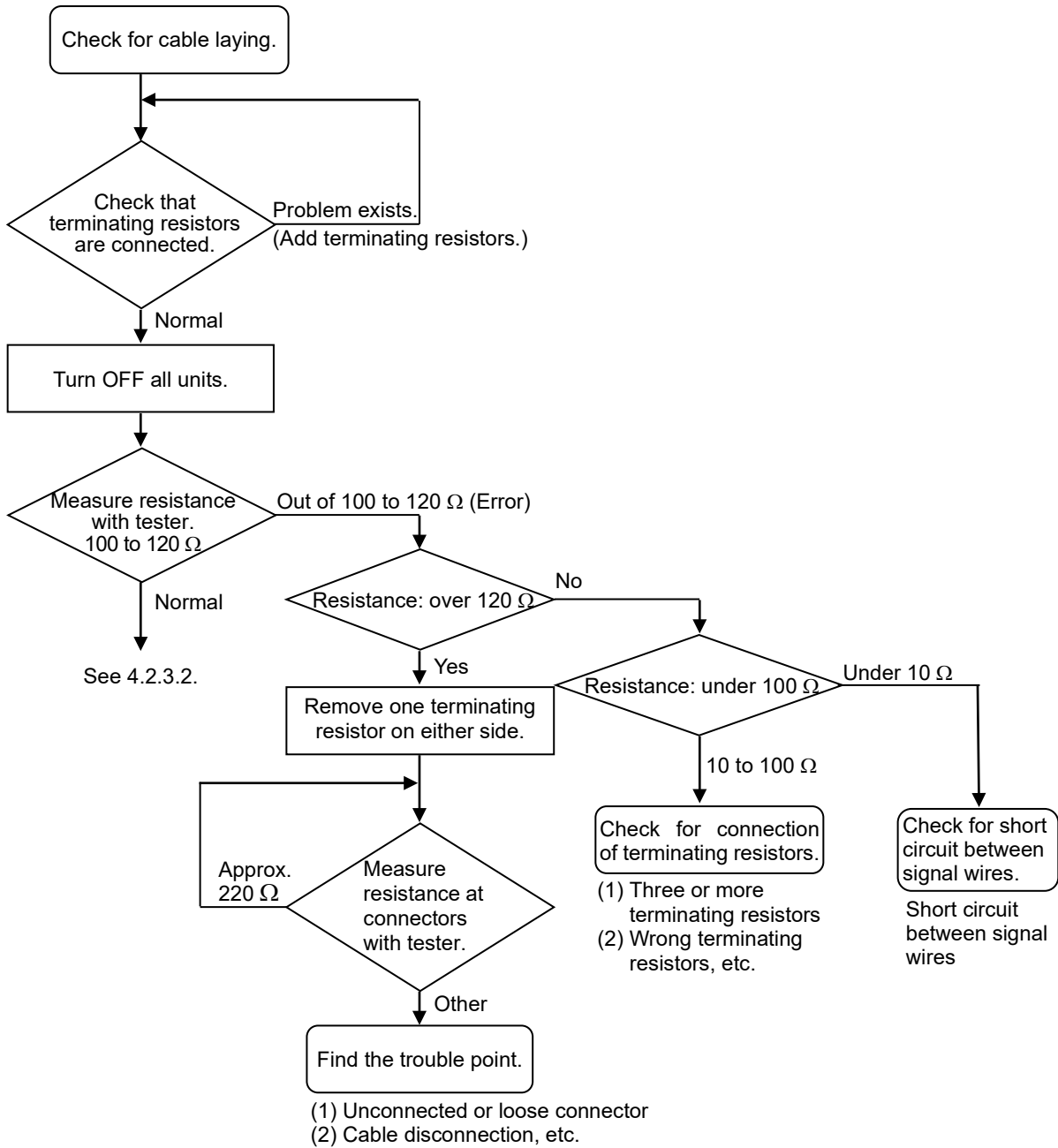

4.2.3.2 Loose Connector and Signal Wire

Check for the connections of the following parts on the connector and cable.

- 1. Connection of connector and signal wire

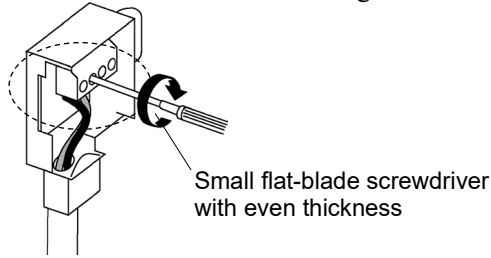

- 2. Connection of connector and unit

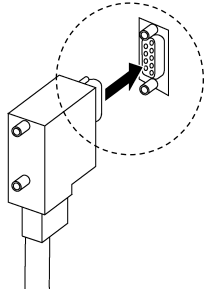

4.2.3.3 Noise Intrusion

Verify how error occurrence condition changes while taking the following countermeasures.

- ◆ Ground of FG wire

Normal Grounding: Peel the cable covering and ground the FG wire.

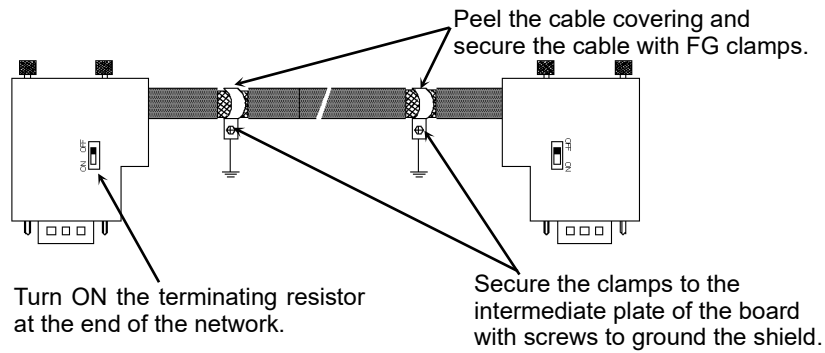

Countermeasure 1: Improve FG.

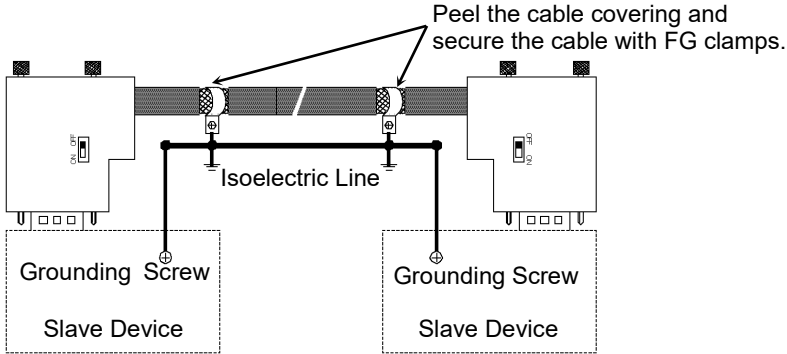

Countermeasure 2: Disconnect the FG wire to isolate it from the ground.

When noise intrudes the ground line due to a noise source such as an inverter installed near the grounding point, disconnect the shield wire of the signal cable and isolate it from the ground to restrain noise intrusion.

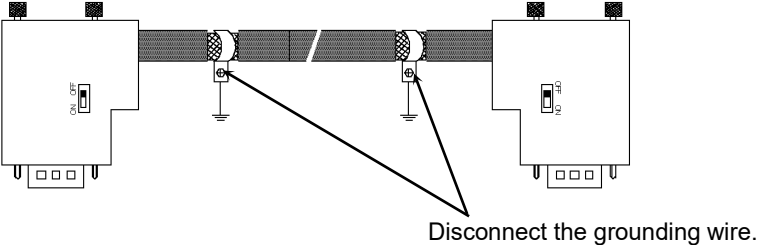

◆ Induced noise via communication cable

Separate the PROFIBUS DP signal wire from the other wires (especially power wires).

* Separate the signal wire from the power wires 300 mm or more.

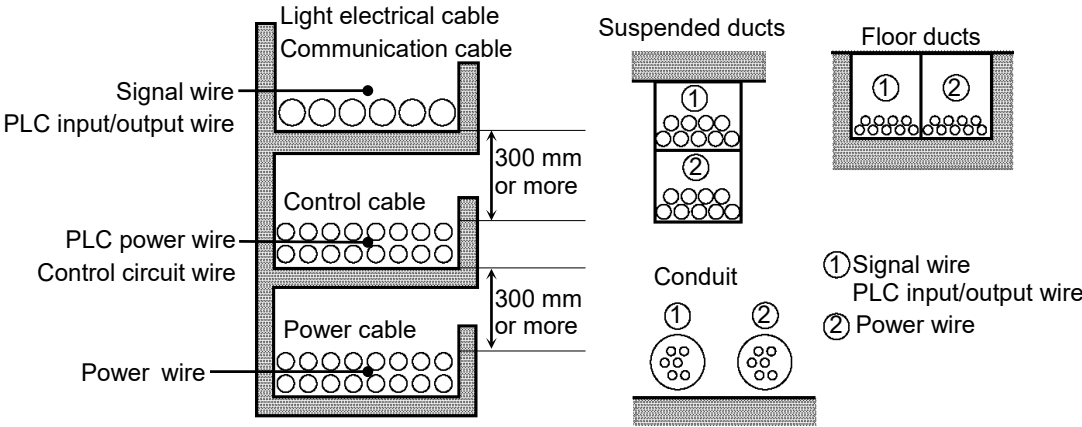

During site inspection, bypass the wire that is possibly affected by induced noise with other cables and then lay the cables. Establish the communication under no induced noise condition and verify whether an error occurs.

4.2.3.4 Broken Unit Examination (Dividing Network Examination)

When you cannot quickly find the trouble point due to broken unit, connection failure including loose connector, or cable partial disconnection, divide the network to find the trouble point. Verify how error occurrence conditions change while taking the following countermeasures.

How to Examine

Divide the network to find which station is a cause of a trouble.

Verify that a master can establish communications with the slaves even though one slave is separated from the network.

After finding the trouble station, check the cables connected to it and replace the unit.

How to Divide

Divide the network by block and check each block.

1. Ensure that the master has no problem by connecting it to its slaves one by one.
(BF/ST: light OFF/green light ON or blinking)
2. Divide the network in the middle of it and check for the communication condition.
(BF/ST: light OFF/green light ON or blinking)
Normal: The trouble point is on the other half of the network.
Error: The trouble point is on the current half of the network.
(Continue dividing the half of the network further to distinguish error part from normal part.)
3. Check for communication on the block to specify the trouble point.

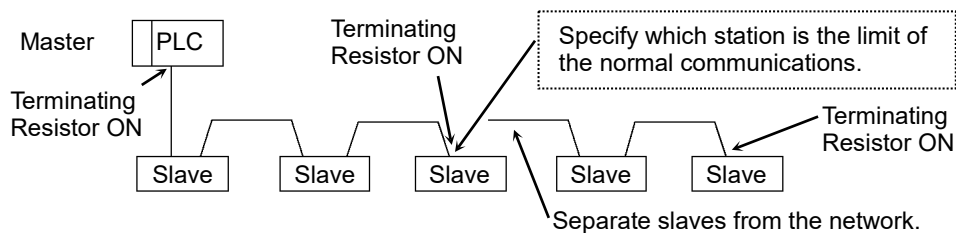

4.2.3.5 Network Configuration and Specifications

1. Maximum Cable Length

Check that the cables used on the network meet the following specifications.

Baud Rates	Max. Cable Length
12 Mbps	100 m
6 Mbps	100 m
3 Mbps	100 m
1500 kbps	200 m
500 kbps	400 m
187.5 kbps	1000 m
93.75 kbps	1200 m
19.2 kbps	1200 m
9.6 kbps	1200 m

2. Terminating Resistor

Ensure that two terminating resistors are connected to both ends of the network. The terminating resistor should be connected as shown below.

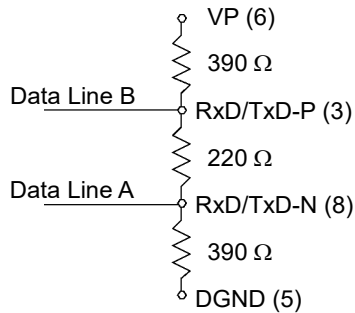

3. Cable

The cables should meet the PROFIBUS specifications.

Item	Property
Impedance	135 to 165 Ω
Capacity	< 30 pf/m
Loop resistance	110 Ω/km
Wire diameter	0.64 mm
Core cross-section	> 0.34mm ²

4.2.3.6 Epson RC+ Master Configuration

For details of Epson RC+ master configuration, refer to the section 2.2.3 *Installing PROFIBUS-DP Master Board Manufactured by molex.*

The following section describes the procedure for verifying the scanner board condition with the applicomIO Console application.

Verifying applicomIO Console application condition

The status bar at the bottom of the window shows the applicomIO Console application status. The status bar varies as shown below:

Character : The address number of the scanner board is indicated with characters. When the character “F” appears, the flash memory on the board initialized the scanner board.

Background color : The background color indicates the scanner board status. For details, refer to the table below.

Background	Character	Status
Gray	Black	Access to scanner board was failed. After that, the status bar will not be renewed automatically. To renew the status bar, right-click the status bar and select [Refresh].
Magenta	Black	The scanner board was initialized with the earlier version applicomIO Console application. It is recommended that the scanner board be written into the flash memory (reinitializing the scanner board) again with the current version applicomIO Console application.
Red	Black	The scanner board was not initialized. Initialize the scanner board to use it.
Yellow	Black	The scanner board was partially initialized. This status happens only during network detection and on-line actions.
Deep green	White	Although the scanner board was initialized, it is different with the currently opened configuration. (Different version, etc.) It is recommended that the scanner board be written into the flash memory (reinitializing the scanner board) again with the current version applicomIO Console application. This status happens only during network detection, on-line actions, and diagnostic.
Green	Black	The scanner board was initialized properly and it is no different with the currently opened configuration. This status happens only during network detection, on-line actions, and diagnostic.

Verifying the PROFIBUS DP network condition

The applicomIO Console application has the following functions:

- Network Monitor function : Monitoring error condition detected on the network
- Diagnostic function : Network diagnosis

1. Select the [Network Detection] tab in the left center of the applicomIO Console application.

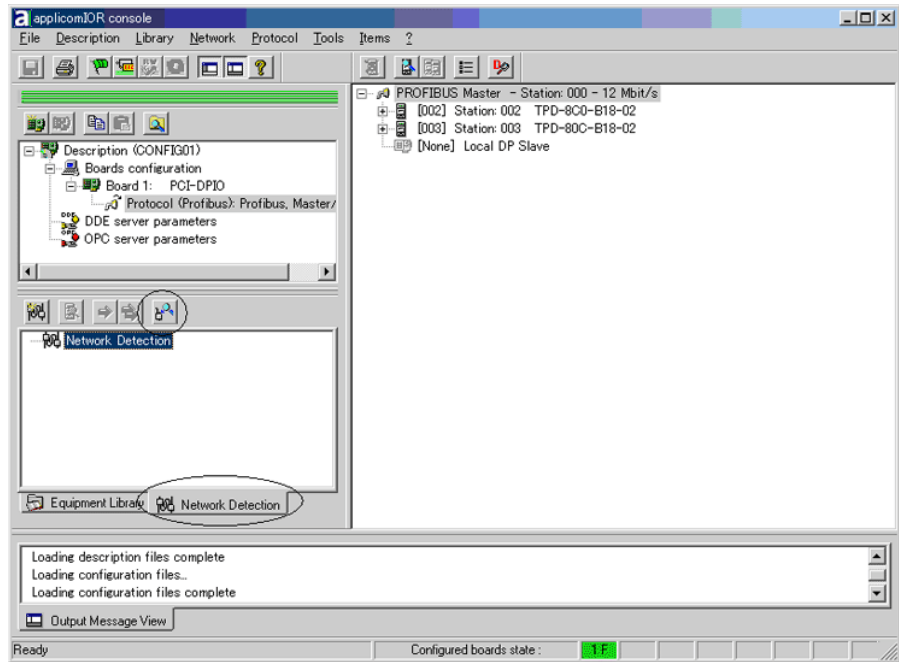

2. Click the [Online Action] icon. The [Network Monitor] dialog box appears.

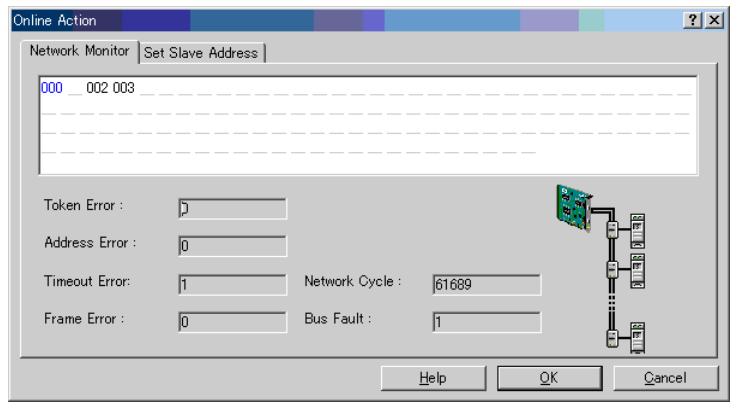

You can check the conditions of the following errors on this dialog box.

- Token Error Address Error Timeout Error
- Frame Error Network Cycle Bus Fault

When an error occurs on the network, it is added to the corresponding error counter.

4. Troubleshooting (PROFIBUS DP)

3. Select [Protocol]-[Diagnostic] from the applicomIO Console application menu. Click the magnifying glass icon on the [Diagnostic] dialog box. Then, select the slave you want from the device tree in the left side of the window. The window changes as shown below.

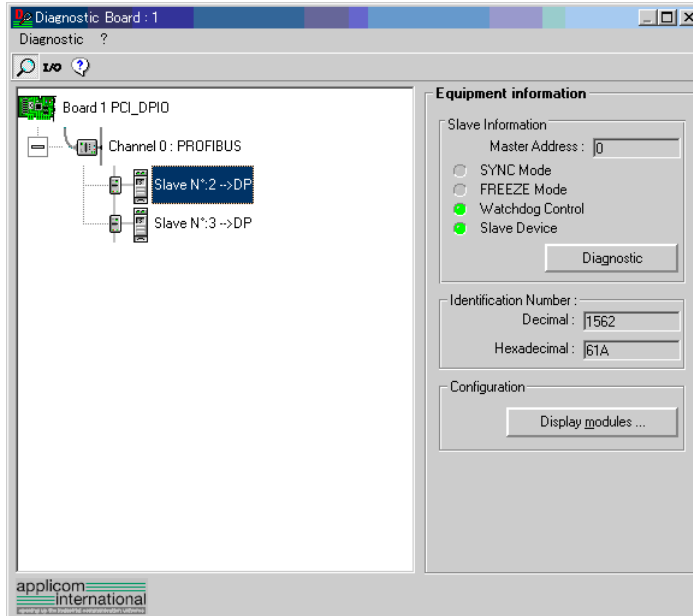

To check the device condition in detail, click [Diagnostic] in [Equipment information] in the right side of the window. If an error occurs, the information is displayed in red.

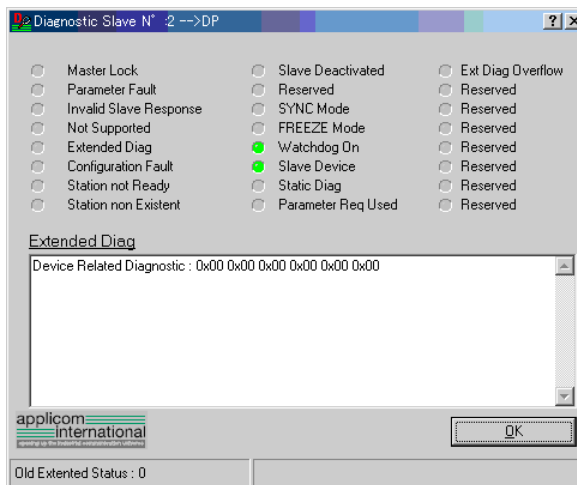

4. When you click the [I/O] icon, the window changes as shown below.

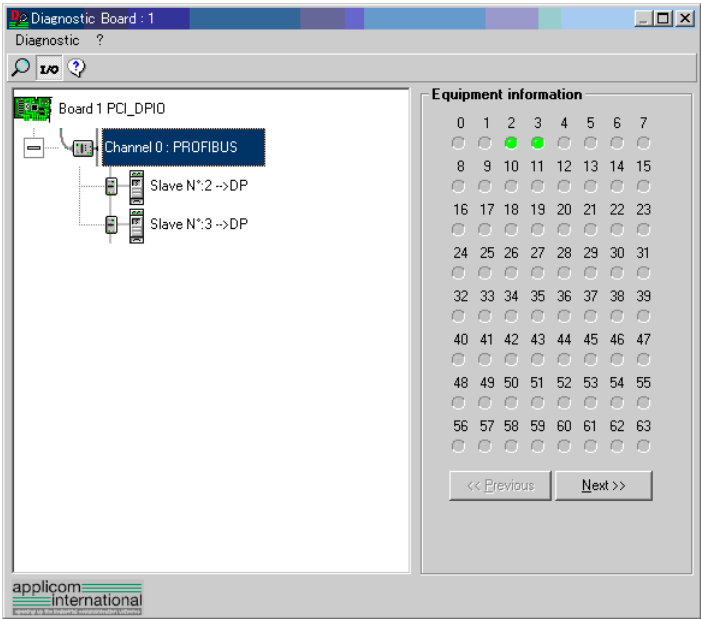

The status of each slave device is shown in the right side of the window. A green circle indicates that the communication of the corresponding device is normal, and a red circle indicates that there is a communication error. A gray circle indicates that the corresponding device does not exist.

5. When you select the slave from the device tree in the left side of the window, the window changes as shown below.

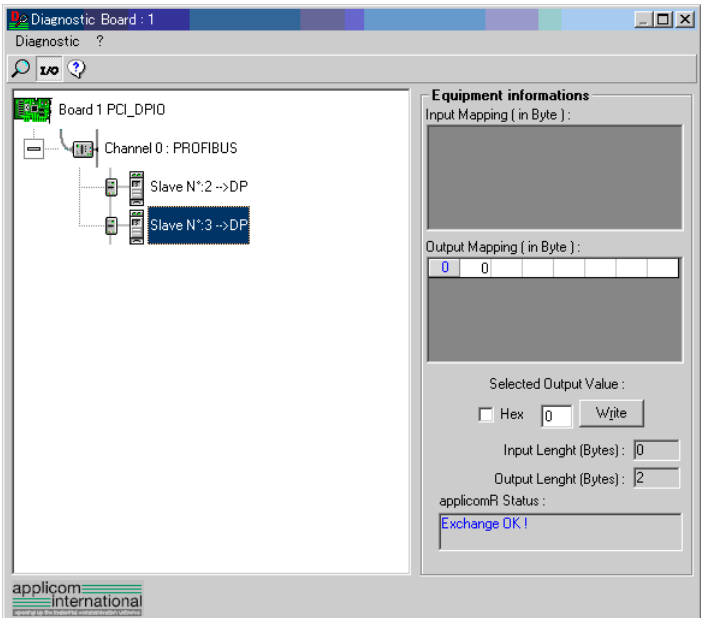

The input and output statuses of the selected device are shown in the right side of the window.

If you want to change output data, click the bite number you want to change in [Output Mapping]. Then, enter a value in [Write] in the “Selected Output Value” and click [Write].

4.3 EtherNet/IP Troubleshooting

Exclusion

Every system has its special environment, conditions, specifications, and usages. This guide is provided as a general reference for troubleshooting a EtherNet/IP network. Every effort has been made to ensure the information is accurate. However, we do not guarantee the complete accuracy of the information and thus we decline any liability for damages or costs incurred by the use of this troubleshooting.

Before examining a problem on the network, please ensure that your established DeviceNet system satisfies network specifications. (Refer to this troubleshooting and the section 2.3.2 *EtherNet/IP Network Construction*.)

4.3.1 Examining a Problem

4.3.1.1 Scanner Board Diagnostic LEDs

The EtherNet/IP board used with Epson RC+ has two status display LEDs. The layout of the LEDs is shown in the following figure.

PCU-ETHIO

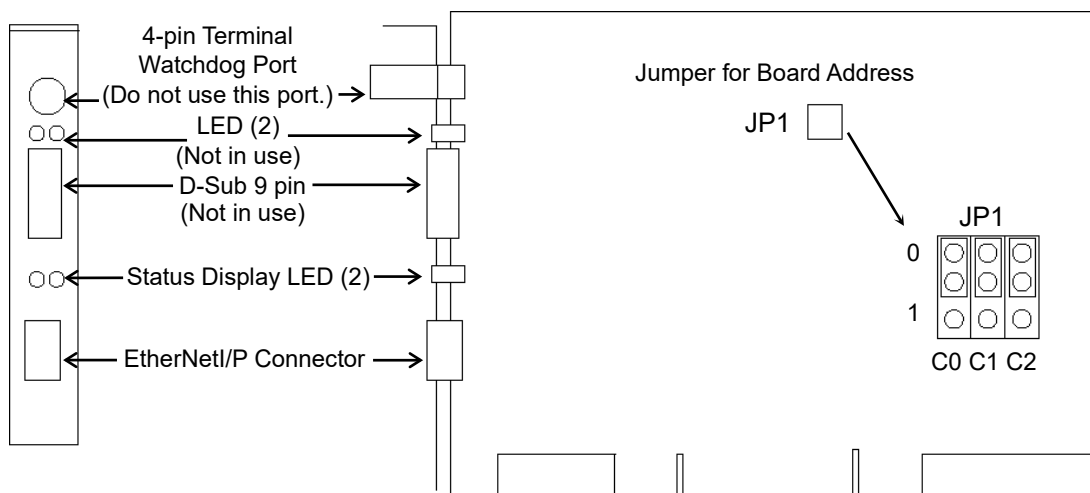

The Module/NetWork LED is on the left and the IO LED is on the right seen from the rear panel. These LED names are used in applicomIO Console application and this manual. Only in this troubleshooting section, general names of the status display of the DeviceNet device are used instead.

The Network Status LED is referred to as the NS LED (NS) in this section.

The Module Status LED is referred to as the MS LED (MS) in this section.

4.3.1.2 Checking Network Status

1. Master Status: MS/NS LEDs

LED	Color	Light Condition
MS (Module Status)	<input type="checkbox"/> Green <input type="checkbox"/> Red	<input type="checkbox"/> ON <input type="checkbox"/> Blinking <input type="checkbox"/> OFF
NS (Network Status)	<input type="checkbox"/> Green <input type="checkbox"/> Red	<input type="checkbox"/> ON <input type="checkbox"/> Blinking <input type="checkbox"/> OFF

2. Node Number of Absent Slaves

Absent slaves are disconnected from or not added to the network.

1. See the status flag regarding to the removal and addition if the master has status information.
2. See the MS/NE LEDs of all slaves if the master has no status information.

3. Absent Slave Status: MS/NS LEDs

LED	Color	Light Condition
MS (Module Status)	<input type="checkbox"/> Green <input type="checkbox"/> Red	<input type="checkbox"/> ON <input type="checkbox"/> Blinking <input type="checkbox"/> OFF
NS (Network Status)	<input type="checkbox"/> Green <input type="checkbox"/> Red	<input type="checkbox"/> ON <input type="checkbox"/> Blinking <input type="checkbox"/> OFF

4. Physical Node Location of Absent Slave

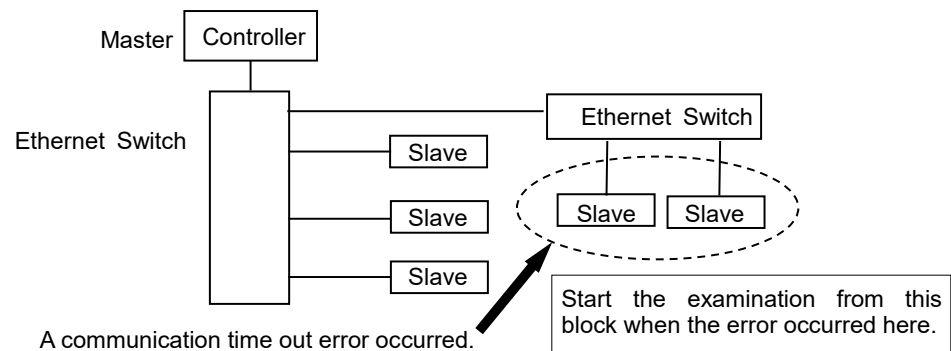

5. Error Occurrence Condition

- Immediate occurrence (high reproducibility)
- Rare occurrence (low reproducibility)

4.3.2 Problems and Countermeasures

Master Unit LED		Error	Description [Reference]
MS	NS		
Green Light ON	Green Light ON	Normal communication	- Normal condition
Green Light ON	Green Light Blinking	During connection establishment	- Processing connection establishment (The NS LED will be ON in green in a few seconds.) - Master function in stop state (Communication does not start.)
Green Light ON	Red Light Blinking	Communication timeout	- Network channel error
Green Light ON	Light OFF	IP address not defined	- The IP address is not defined
Red Light Blinking	No Matter	Critical error	[Refer to the section 4.3.3 Tests and diagnostics.] - Unrecoverable critical error
Red Light ON	No Matter	Module error	[Refer to the section 4.3.3 Tests and diagnostics.] - Recoverable error occurred
Light OFF	Light OFF	Not initialized status	[Refer to the section 2.3.3 Installing EtherNet/IP Master Board Manufactured by moxer - Master Mode.] - The communication board is not initialized Check the configuration

4.3.3 Tests and Diagnostics

4.3.3.1 Diagnostic Tool

After configuring the EtherNet/IP master, adding and configuring the devices of your network and downloading your configuration in the board, the statuses of all devices can be tested with the diagnostic tool.

Start this tool by selecting the menu command [Protocol/Diagnostic...] or selecting the  (Diagnostic) icon.

See also: To display the help, select [Start]-[Program]-[Direct-Link]-[applicomIO 2.3]-[Help].

Ethernet/IP channel on Ethernet diagnostics

The EtherNet/IP on Ethernet channel diagnostic information can be displayed by selecting the MULTI-MSG ETH channel.

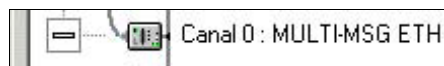

All devices in the configuration are visualized by a LED corresponding to the applicomIO device number.

The LED may be red or green depending on the device error status.

1. Diagnostic of the TCP/IP layer

This dialog box displays the status of the TCP/IP layer.

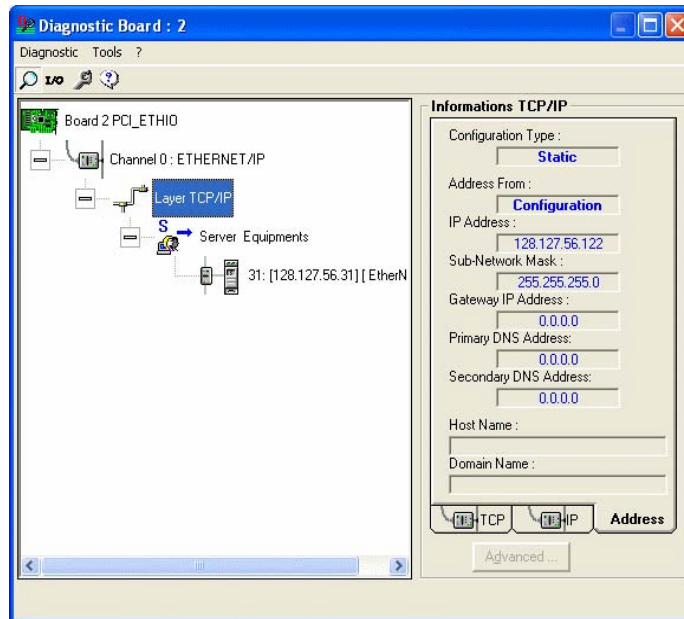

Configuration Type	Mode type selected in the configuration: DHCP, BOOTP, Static
Address From	How the IP address has been obtained: from the server, flash memory or factory address.
IP address	IP address of the applicomIO master on this channel.
Sub-Network Mask	Sub-network address of the applicomIO master on this channel.
Gateway IP Address	Address of the gateway configured on the applicomIO master on this channel.
Primary DNS Address	IP Address of the primary DNS server.
Secondary DNS Address	IP address of the secondary DNS server.
Host Name	Host name of the applicomIO master on this channel.
Domain Name	Domain name of the applicomIO master on this channel.

TCP tab

Passive connections :	0
Active connections :	1
Current connections :	1
Bytes received :	674
Bytes transmitted :	1034
Time-out retransmitted :	0

TCP IP Address

Passive connections

Number of passive connections.

Active connections

Number of active connections.

Current connections

Number of current connections.

Bytes received

Number of bytes received.

Bytes transmitted

Number of bytes transmitted.

Retries on time-out

Number of retries on reception of a time-out.

IP tab

Packets received :	13080
Packets transmitted :	13124
Errors :	0

TCP IP Address

Packets received

Number of packets received.

Packets transmitted

Number of packets transmitted.

Errors

Number of IP errors.

2. Diagnostic of server devices

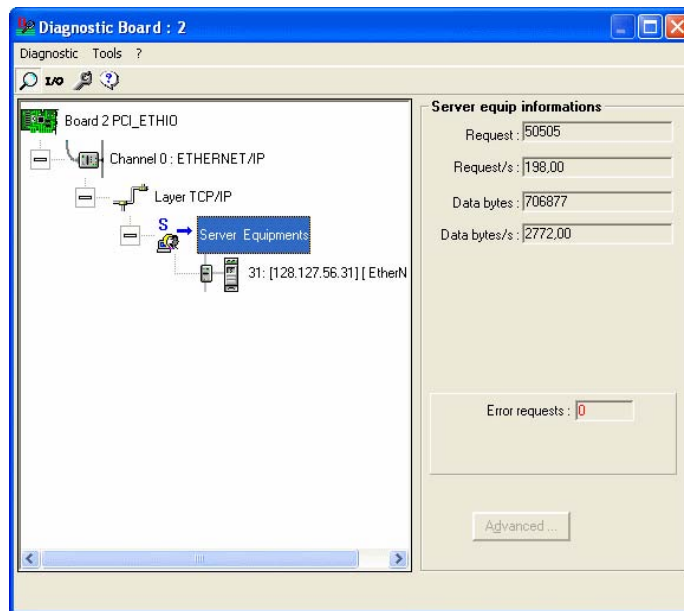

Requests	Number of requests.
Requests / s	Number of requests per second.
Useful bytes	Number of useful data bytes.
Useful bytes / s	Number of useful data bytes per second.
Requests in error	Number of requests in error.

4. Troubleshooting (EtherNet/IP)

3. Overall device diagnostics

View the diagnostic information on a device in the configuration by selecting the node which corresponds to the device.

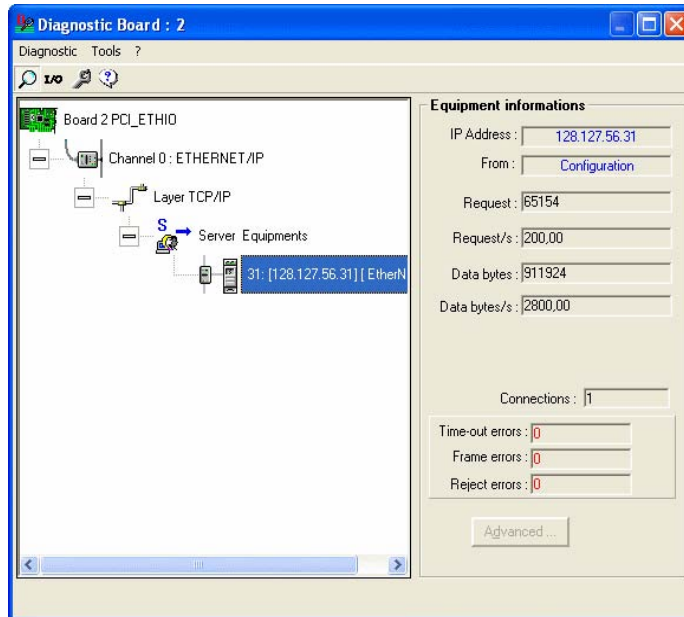

IP Address	IP address of the device.
From	How the IP address of the device was obtained: from the configuration from the DNS server (IP address of the device has been resolved)
Requests	Number of requests.
Requests / s	Number of requests per second.
Useful bytes	Number of useful data bytes.
Useful bytes / s	Number of useful data bytes per second.
Connections	Number of connections created for this device.
Time-out errors	Number of time-outs received for this device.
Frame errors	Number of frame errors for this device.
Refusal errors	Number of errors excluding time-out and frame errors.

TCP/IP tool

By clicking in the  icon and selecting [TCP/IP layer], the [services] window displays the following options.

- DNS
- ICMP (ping)

See also: To display the help, select [Start]-[Program]-[Direct-Link]-[applicomIO 2.3]-[Help].

1. Resolution of IP address or name

DNS functionality can be enabled by selecting the applicomIO menu-[Protocol/Diagnostic···]-the [DNS] tab.

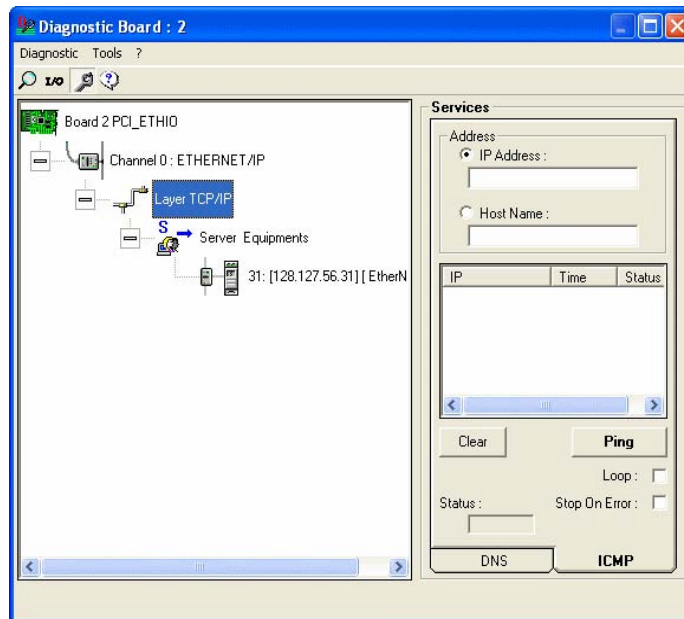

(1) Selects the type of resolution to be carried out.

IP Address : the host name is obtained from the IP address.

Host Name : the IP address is obtained from the host name.

(2) Carries out a resolution.

(3) Status: Status of resolution carried out

0 : No error

33 : Response time-out exceeded

132 : Negative reply from DNS server (SERVER FAILURE, etc.)

2. Ping

ICMP ECHO “PING” functionality can be enabled by selecting the applicomIO menu-[Protocol/Diagnostic...]-the [ICMP] tab.

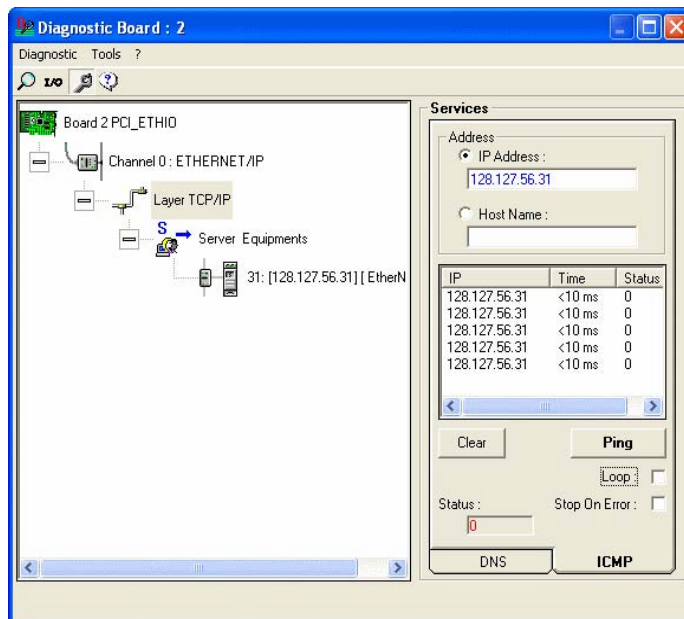

- (1) Entry field for the IP address or name of the remote station.
- (2) Field showing result obtained:
 - Status 0 : The station is present and has responded
(the response time is given in the Time column)
 - Status 33 : The station is not present
- (3) Command field:
 - Clear : Clears the list of results
 - Ping : Sends a PING command
 - Loop : Executes PING command in a loop
 - Stop on Error : If Loop has been selected, stops if an error has occurred
 - Status : Status of the PING request
 - 0 :OK
 - 33 : TIME-OUT
 - 132: Resolution error

4.4 How to Disable Fast Startup in Windows

How to Disable Fast Startup

Follow the steps below to disable the fast startup function.

* After performing this operation, the fast startup function remains disabled unless the setting is enabled again.

1. Click [Start] to display the application list.

Click [Windows System] in “W” field and click [Control Panel].

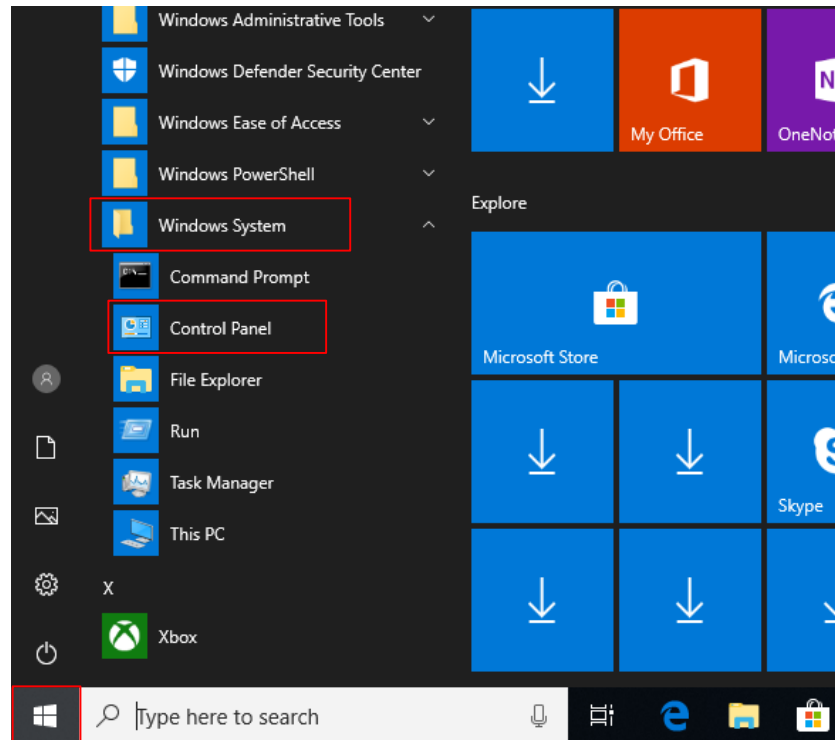

4. Troubleshooting

2. [Control Panel] is displayed.

Make sure that “Category” is selected in [View by] and click [System and Security].

* If Icon is selected in [View by], click [Power Options] and move to the step 4.

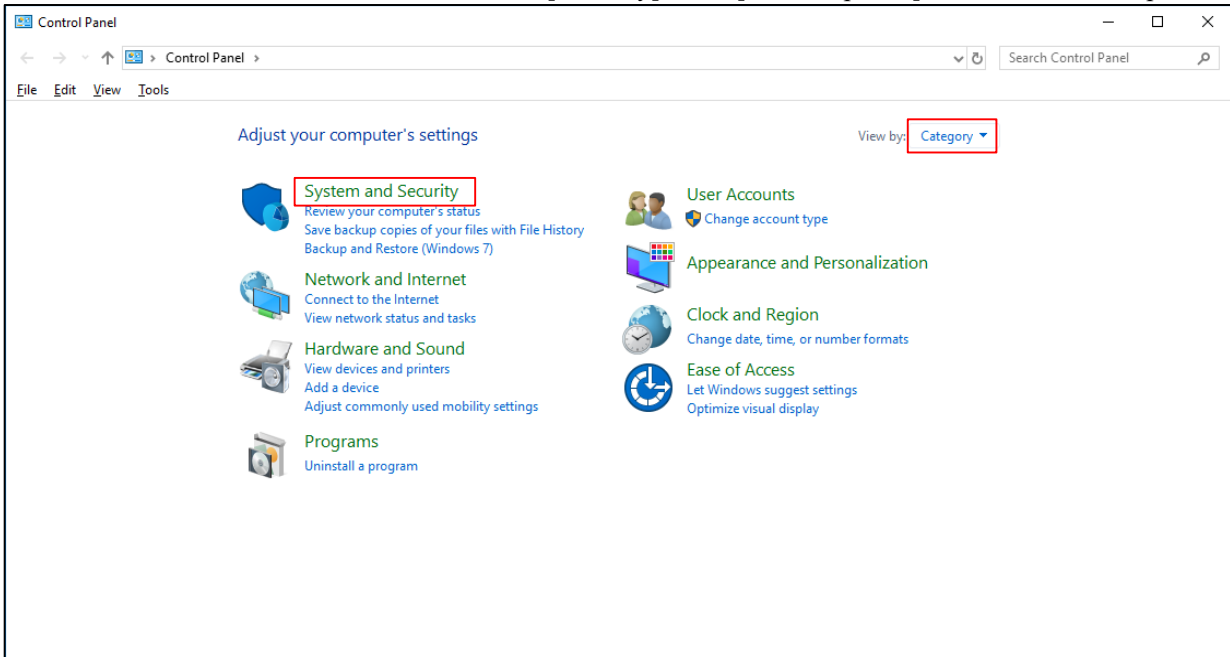

3. [System and Security] is displayed.

Select “Power Options”.

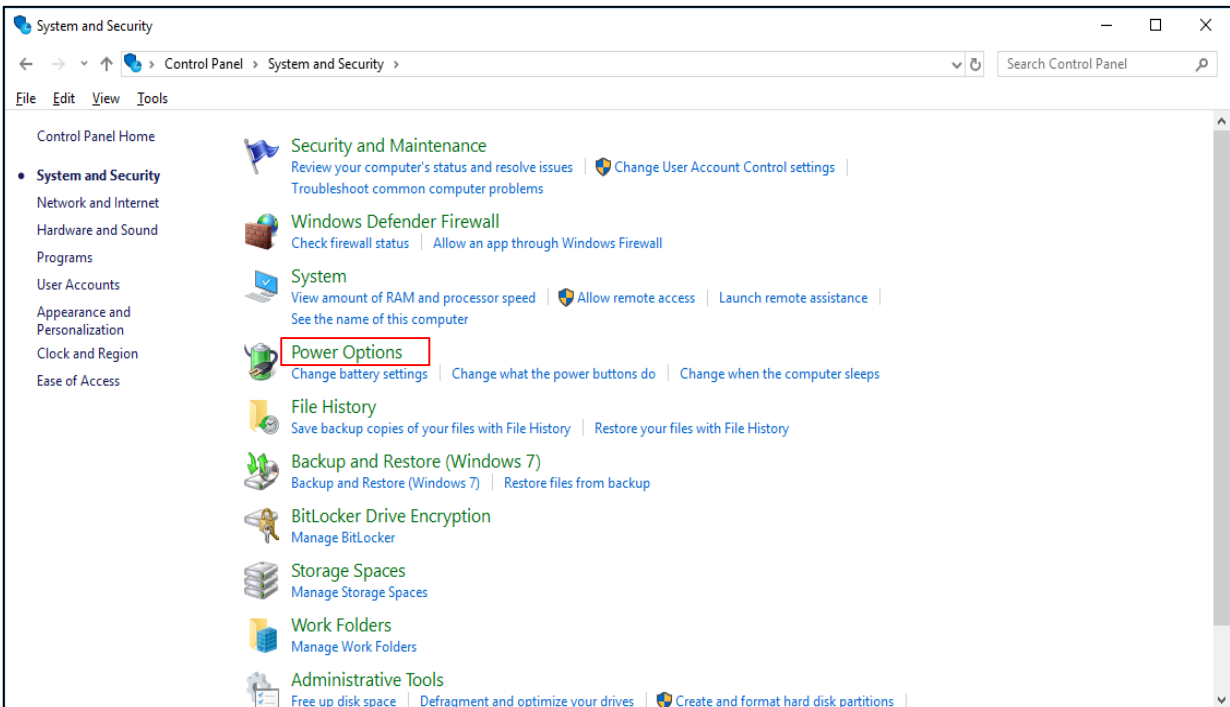

4. [Power Options] is displayed.
Select “Choose what the power buttons do”

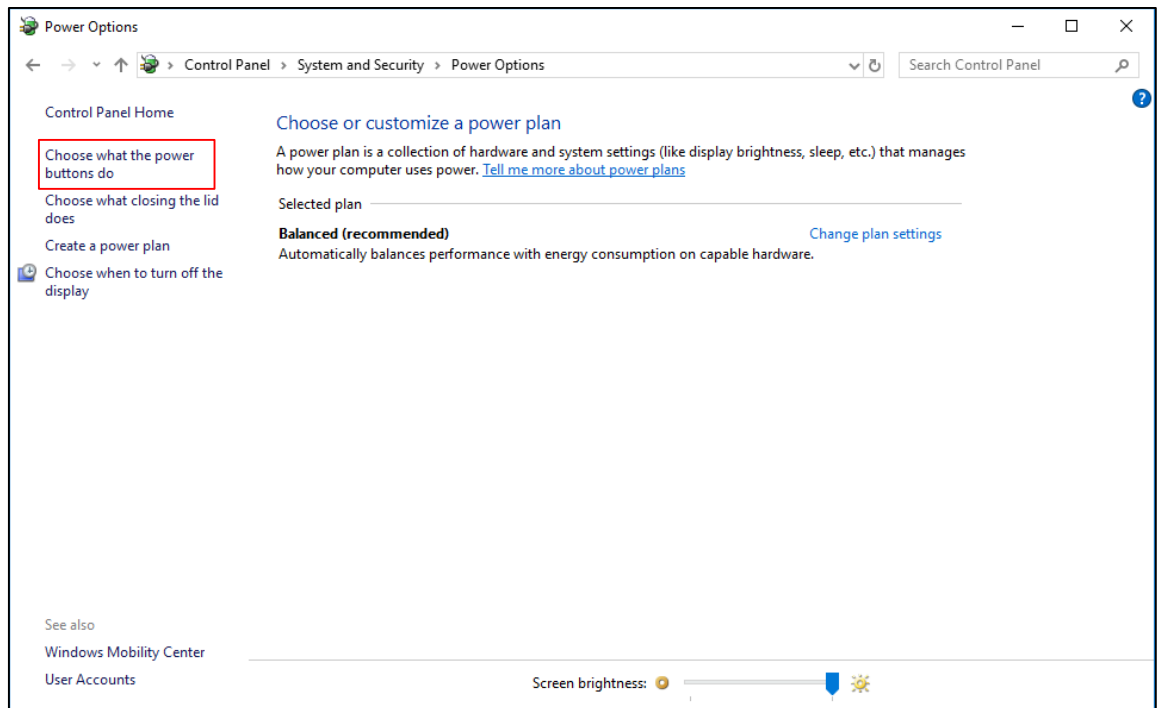

5. [System Settings] is displayed.
Select “Change settings that are currently unavailable”.

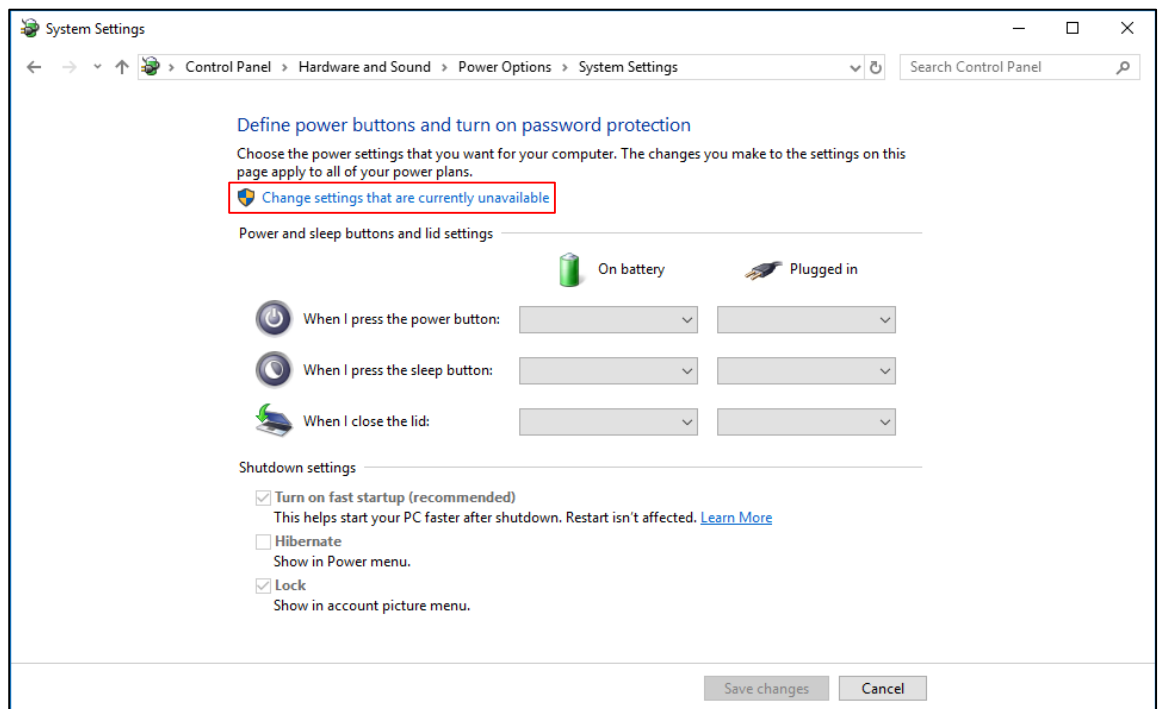

4. Troubleshooting

6. Deselect the checkmark of “Turn on fast startup” of [Shutdown settings] and click [Save changes].

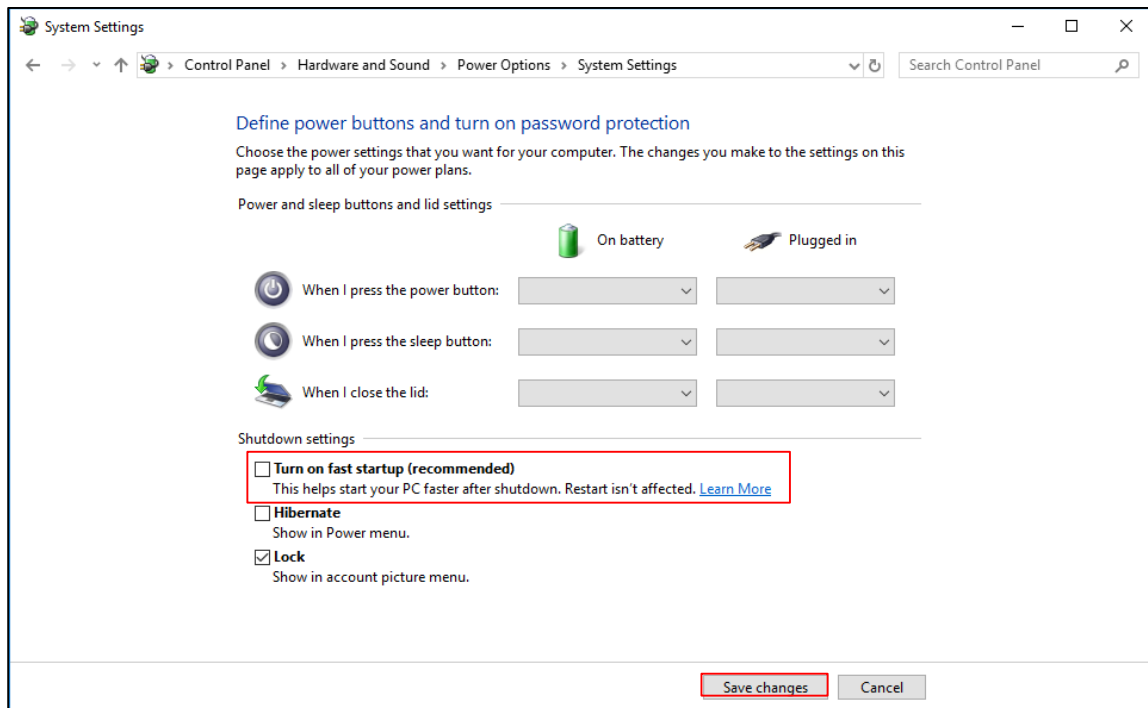

Now, the setting is complete.

PC will turn ON with fast startup disabled from the next time.

4.5 Disabling the PCI Express Native Setting

To disable the PCI Express Native setting, follow the steps below.

1. Start Command Prompt with administrator authority.

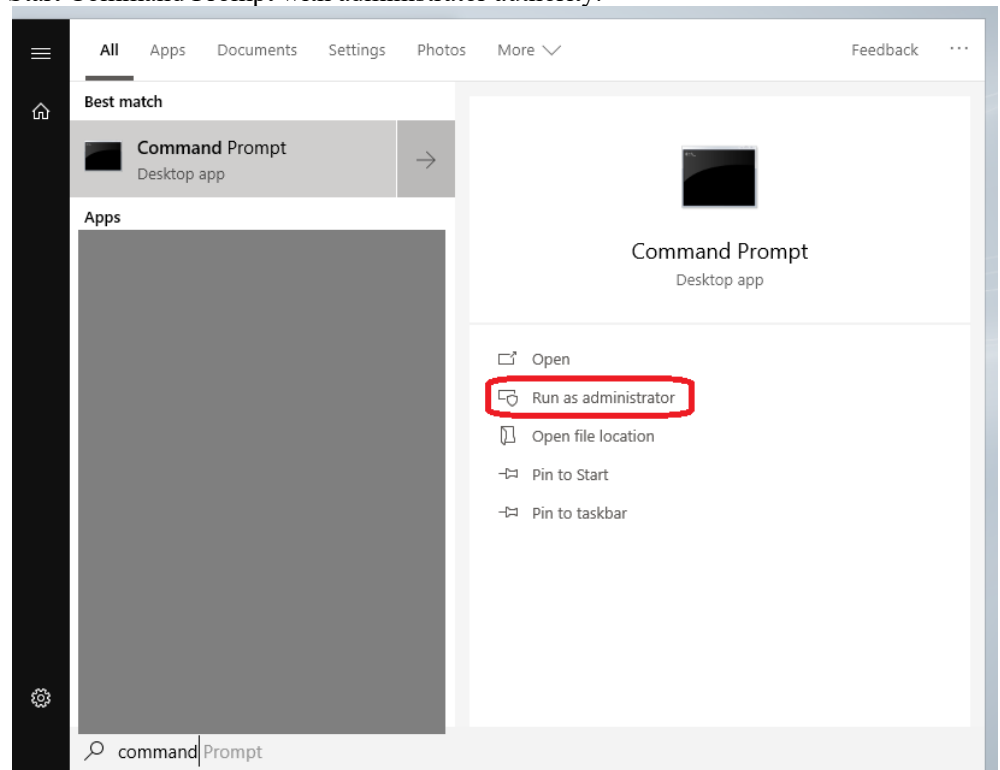



2. Enter the command below and run.
`bcdedit /set pciexpress forcedisable`

```
C: [redacted] >bcdedit /set pciexpress forcedisable
The operation completed successfully.
```

3. Restart the PC.

5. Maintenance Parts List



Fieldbus Type	Supported Model		
	RC700 series, RC90 series	T series, VT series (*1)	RC800 series
DeviceNet	R12NZ9004F (Old Code: R12B040727)	R12NZ900TE	R12NZ901L7
PROFIBUS-DP	R12NZ9004H (Old Code: R12B040729)	R12NZ900TF	R12NZ901L8
CC-Link	R12NZ9004J (Old Code: R12B040730)	R12NZ900TD	R12NZ901LC
EtherNet/IP	R12NZ900A7 (Old Code: R12N747061)	R12NZ900TH (*2)	R12NZ901LA
PROFINET	R12NZ900A6 (Old Code: R12N747051)	R12NZ900TG (*2)	R12NZ901LB
EtherCAT	R12NZ900CL (Old Code: -)	R12NZ900TX (*2)	R12NZ901L9
	<p>Example of slave board</p> 	<p>Example of slave module</p> 	

*1 : Including protected-model

*2 : When the Controller firmware version is before 7.5.54.14

Fieldbus Type	Code
EtherNet/IP	2230646
PROFINET	2230647
EtherCAT	2230648

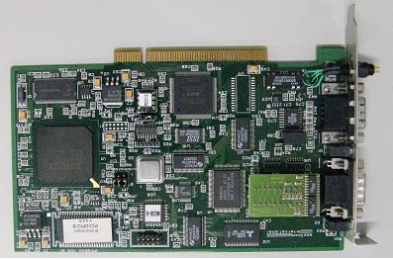
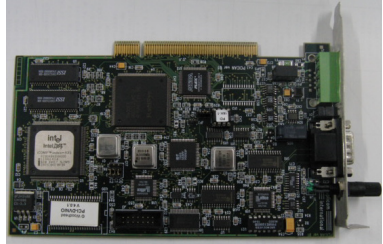
Master

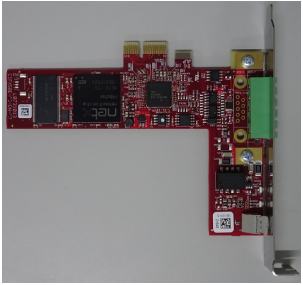
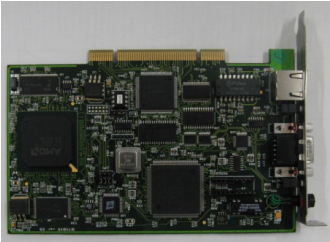
Part Name	Board	Code
PROFIBUS-DP board (PCI) manufactured by molex		2174735
DeviceNet board manufactured by molex (PCI)		2174734
DeviceNet board manufactured by Hilscher (PCI)		2208434
DeviceNet board (PCI-e) manufactured by Hilscher		2211543
EtherNet/IP board manufactured by molex (PCI)		2174736

5. Maintenance Parts List

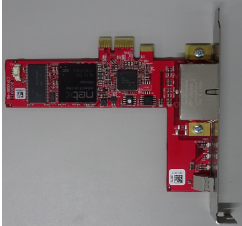
Part Name	Board	Code
EtherNet/IP board manufactured by Hilscher (PCI)		2208435
EtherNet/IP board (PCI-e) manufactured by Hilscher		2211542