

EPSON

Epson RC+ 8.0 Option Force Guide 8.0 (RC800 series)

Original instructions

© Seiko Epson Corporation 2024

Rev.2
ENM24ZS6951F

Table of Contents

1. FOREWORD	14
1.1 FOREWORD	15
1.2 TRADEMARKS	15
1.3 TRADEMARK NOTIFICATION IN THIS MANUAL	15
1.4 Terms of Use	15
1.5 Manufacturer	15
1.6 Contact Information	15
1.7 FOREWORD	16
1.8 Training	16
2. Installation	17
2.1 FOREWORD	18
2.1.1 Overview of Force Guide 8.0	18
2.1.2 Necessary Basic Knowledge of Epson RC+ 8.0	19
2.1.3 Training	19
2.2 Definition of Terms	20
2.3 System Overview	24
2.4 Functions of Force Guide 8.0	25
2.4.1 Overview	25
2.4.2 Force control function	25
2.4.2.1 Overview of the Force Control Function	25
2.4.2.2 Parameters of the Force Control Function	25
2.4.3 Force trigger function	26
2.4.4 Force monitor function	26
2.4.5 Force motion restriction function	26
2.4.6 Force guidance function	27
2.4.6.1 Overview of the Force Guidance Function	27
2.4.6.2 Force Guide Sequence	27
2.4.6.3 Force Guide Object	28
2.4.7 Direct Teach + Touch Jog	30
2.5 Robot local	32
2.5.1 About Coordinate Systems	32
2.5.2 Force coordinate system	33

2.5.3 Force Sensor coordinate system	33
2.6 Setting Up Force Guide 8.0	34
3. Hardware	36
3.1 Included Items	37
3.1.1 S2503, S2506, S25010 (for the GX series)	37
3.2 Label	39
3.3 Connection Example	41
3.3.1 G series, GX series-S2503, S2506, S25010	41
3.3.1.1 Internal wiring	41
3.3.1.2 External wiring	42
3.4 Force Sensor	43
3.4.1 Specification	43
3.4.1.1 Specification Table	43
3.4.1.2 ACCEL Setting under Heavy Load	44
3.4.2 Outer dimensions	44
3.4.2.1 S2503, S2506, S25010 (for the GX series)	45
3.5 How to Install	47
3.5.1 Installing the Force Sensor	48
3.5.1.1 S2503, S2506, S25010 (for the GX series)	48
3.5.2 End Effector	50
3.5.2.1 Guidelines of Allowable Moment	50
3.5.2.2 Guidelines for Joint Torque	51
3.5.2.2.1 Check of Joint Peak Torque	51
3.5.2.2.2 Overload Rate of Joint	51
3.5.2.3 Cautions about Wires and Pipes	52
3.5.2.4 Precautions When Handling Heavy Loads or Heavy Objects	53
3.5.3 Wiring of the Force Sensor Cable	53
3.5.3.1 GX series-S2503, S2506, S25010	53
3.6 Maintenance Parts List	57
3.6.1 Force Sensor	57
4. Software	58
4.1 Checking the Connection	59
4.1.1 Configuring the Force Sensor Unit	59
4.1.1.1 Force Sensor Connection Procedure	60

4.1.1.2 Force Sensor Disconnection Procedure	61
4.1.1.3 Force Sensor Replacement Procedure	61
4.1.2 Checking the Connection	61
4.1.2.1 Checking the Connection	61
4.1.2.2 Checking the Acquisition of Output Values	62
4.1.3 Checking the Accuracy of the Force Sensor	62
4.1.3.1 Overview	62
4.1.3.2 Acquisition of the Initial Data	63
4.1.3.3 Acquisition of the Comparison Data and Comparison with the Initial Data	64
4.2 Force Sensor Correction	66
4.2.1 Resetting the Force Sensor	66
4.2.2 Coordinate Conversion	66
4.2.3 Gravity Compensation	67
4.2.3.1 Overview	67
4.2.3.2 Manually define mass properties	68
4.2.3.3 Gravity Direction	68
4.2.3.4 Executing Gravity Compensation	69
4.2.4 Checking the Gravity Compensation Operation	69
4.3 Force Guide 8.0 Graphical User Interface (GUI)	73
4.3.1 Project Explorer	73
4.3.1.1 Force File	73
4.3.1.2 Force Guide	74
4.3.2 [File] menu	74
4.3.2.1 [New File] (File Menu)	75
4.3.2.2 [Open File] (File Menu)	75
4.3.2.3 [Close File] (File Menu)	75
4.3.2.4 [Save File] (File Menu)	75
4.3.2.5 [Save As] (File Menu)	76
4.3.2.6 [Delete File] (File Menu)	76
4.3.2.7 [Import File] (File Menu)	76
4.3.2.8 [Exit] (File Menu)	77
4.3.3 [Edit] menu	78
4.3.3.1 [Cut] (Edit Menu)	78
4.3.3.2 [Copy] (Edit Menu)	78
4.3.3.3 [Paste] (Edit Menu)	78

4.3.3.4 [Select All] (Edit Menu)	78
4.3.4 [Project] Menu	78
4.3.4.1 [Open Project] (Program Menu)	78
4.3.4.2 [Edit Project] (Project Menu)	79
4.3.4.3 [Save Project] (Project Menu)	80
4.3.4.4 [Project Properties] (Project Menu)	80
4.3.5 [Tools] menu	81
4.3.5.1 [Robot Manager] (Tools Menu)	81
4.3.5.1.1 [Tools]- [Robot Manager]-[Mass/Gravity] Panel	88
4.3.5.2 [Force Monitor] (Tools Menu)	93
4.3.5.2.1 The [Mode]-[Live] button	93
4.3.5.2.1.1 Details of the displayed dialog box	93
4.3.5.2.1.2 "Live" Flow	94
4.3.5.2.1.3 "Live" flow when enabling the trigger function	96
4.3.5.2.2 [Mode]-[Runtime] button	98
4.3.5.2.2.1 Details of the displayed dialog box	98
4.3.5.2.2.2 Graph display when executing the force guide sequence	99
4.3.5.2.2.3 Graph display when the record is executed by the force monitor object	100
4.3.5.2.3 [Mode]-[Log] button	101
4.3.5.2.3.1 Details of the displayed dialog box	101
4.3.5.2.3.2 How to Load a Single Log File	103
4.3.5.2.3.3 How to Load Multiple Log Data Files	104
4.3.5.2.4 Graph	109
4.3.5.2.4.1 Single File	110
4.3.5.2.4.2 Multiple Files	114
4.3.5.2.4.3 Common functions	118
4.3.5.3 [Maintenance] (Tools Menu)	122
4.3.5.4 [Force Guidance] (Tools Menu)	124
4.3.6 Force Editor	150
4.3.7 [System Configuration] menu	151
4.3.7.1 Force Sensor	151
4.3.8 Sequence Reconcile Function	151
4.3.8.1 Sequence Reconcile Function for Force Guide Sequences	151
4.3.8.2 Sequence Reconcile Function for Force Files	153

4.4 Force guidance function	155
4.4.1 Steps and Basic Concepts for using the Force Guidance Function	155
4.4.1.1 Using the SPEL+ Language to Create Motions Prior to Starting Force Control Function	155
4.4.1.2 Set a force guide sequence	156
4.4.1.2.1 Step 2-1. Create a force guide sequence	156
4.4.1.2.2 Step 2-2. Set the properties of the force guide sequence	157
4.4.1.3 Set force guide object(s)	157
4.4.1.3.1 Step 3-1. Break down an operation into force guide objects	159
4.4.1.3.2 Step 3-2. Align force guide objects	164
4.4.1.3.3 Step 3-3. Set properties of force guide objects	164
4.4.1.4 Adjust While Executing Test	169
4.4.1.5 Execute a force guide sequence using the SPEL+ language	170
4.4.2 General Sequence and Object	171
4.4.2.1 General Sequence	171
4.4.2.1.1 Property setting guidelines for general sequence	171
4.4.2.1.2 Details on properties of general sequences	176
4.4.2.1.3 Details on results of general sequence	183
4.4.2.2 General force guide object	184
4.4.2.2.1 Contact Object	184
4.4.2.2.1.1 Property setting guidelines for the Contact object	185
4.4.2.2.1.2 Adjustment guideline for Contact object	187
4.4.2.2.1.3 Details on properties of the Contact object	188
4.4.2.2.1.4 Details on the results of the Contact object	192
4.4.2.2.2 Relax Object	193
4.4.2.2.2.1 Property Setting Guideline for Relax Object	194
4.4.2.2.2.2 Adjustment guideline for Relax object	197
4.4.2.2.2.3 Details on properties of the Relax object	197
4.4.2.2.2.4 Details on the results of the Relax object	204
4.4.2.2.3 FollowMove Object	205
4.4.2.2.3.1 Property setting guidelines for FollowMove object	206
4.4.2.2.3.2 Adjustment guideline for FollowMove object	216
4.4.2.2.3.3 Details on properties of the FollowMove object	217
4.4.2.2.3.4 Details on results of the FollowMove object	230
4.4.2.2.4 SurfaceAlign Object	231
4.4.2.2.4.1 Property setting guidelines for the SurfaceAlign object	232

4.4.2.2.4.2 Adjustment guidelines for the SurfaceAlign object	236
4.4.2.2.4.3 Details on properties of the SurfaceAlign object	236
4.4.2.2.4.4 Details on the results of the SurfaceAlign object	241
4.4.2.2.5 PressProbe Object	242
4.4.2.2.5.1 Property setting guidelines for the PressProbe object	243
4.4.2.2.5.2 Adjustment guidelines for the PressProbe object	252
4.4.2.2.5.3 Details on the properties of the PressProbe object	253
4.4.2.2.5.4 Details on results of the PressProbe object	261
4.4.2.2.6 ContactProbe Object	262
4.4.2.2.6.1 Property setting guidelines for the ContactProbe object	263
4.4.2.2.6.2 Guidelines for Adjusting ContactProbe Object	269
4.4.2.2.6.3 Also, adjust the start point of ContactProbe object to the hole position as close as possible.	270
4.4.2.2.6.4 Details on the results of the ContactProbe object	275
4.4.2.2.7 Press Object	276
4.4.2.2.7.1 Property setting guidelines for the Press object	278
4.4.2.2.7.2 Adjustment guidelines for the Press object	287
4.4.2.2.7.3 Details on the properties of the Press object	287
4.4.2.2.7.4 Details on the results of the Press object	300
4.4.2.2.8 PressMove Object	302
4.4.2.2.8.1 Property setting guidelines for the PressMove object	303
4.4.2.2.8.2 Adjustment guidelines for the PressMove object	315
4.4.2.2.8.3 Details on the properties of the PressMove object	315
4.4.2.2.8.4 Details on the results of the PressMove object	334
4.4.2.2.9 Decision Object	335
4.4.2.2.9.1 Property setting guidelines for the Decision object	335
4.4.2.2.9.2 Details on properties of the Decision object	336
4.4.2.2.10 SPELFunc Object	336
4.4.2.2.10.1 Property setting guideline for SPELFunc object	337
4.4.2.2.10.2 Details on the properties of the SPELFunc object	337
4.4.2.2.10.3 Details on results of the SPELFunc object	339
4.4.3 Paste Sequence and Object	339
4.4.3.1 Setting Guidelines for the Paste Sequence Wizard	340
4.4.3.2 Paste Sequence	357
4.4.3.2.1 Property setting guidelines for Paste sequence	357

4.4.3.2.2 Details on properties of Paste sequence	360
4.4.3.2.3 Details on the results of the Paste sequence	365
4.4.3.3 Paste Object	366
4.4.3.3.1 Property guideline for Paste object	367
4.4.3.3.2 Details on properties of Paste object	371
4.4.3.3.3 Details on results of Paste object	374
4.4.3.4 Adjustment Guidelines for the Paste sequence and Object Property Values	376
4.4.4 ScrewTighten Sequence and Object	377
4.4.4.1 Sequence Wizard for a ScrewTighten Sequence	377
4.4.4.2 ScrewTighten Sequence	393
4.4.4.2.1 Property setting guidelines for ScrewTighten sequence	393
4.4.4.2.2 Details on properties of the ScrewTighten sequence	396
4.4.4.2.3 Details on results of ScrewTighten sequence	402
4.4.4.3 ScrewTighten Object	403
4.4.4.3.1 Property guideline for ScrewTighten object	404
4.4.4.3.2 Details on the properties of the ScrewTighten object	406
4.4.4.3.3 Details on results of ScrewTighten object	410
4.4.4.4 ScrewRetighten Object	412
4.4.4.4.1 Property guidelines for the ScrewRetighten object	412
4.4.4.4.2 Details on the properties of the ScrewRetighten object	413
4.4.4.4.3 Details on the results of the ScrewRetighten object	415
4.4.4.5 Adjustment Guideline for ScrewTighten Sequence and Object Property Values	416
4.4.5 HeightInspect Sequence and Object	417
4.4.5.1 Sequence Wizard for a HeightInspect Sequence	418
4.4.5.2 HeightInspect Sequence	433
4.4.5.2.1 Property setting guidelines for HeightInspect sequence	433
4.4.5.2.2 Details on properties of HeightInspect sequence	436
4.4.5.2.3 Details on results of HeightInspect sequence	441
4.4.5.3 HeightInspect Object	443
4.4.5.3.1 Property guidelines for HeightInspect object	444
4.4.5.3.2 Details on properties of HeightInspect object	447
4.4.5.3.3 Details on results of HeightInspect object	450
4.4.5.4 Adjustment Guidelines for the HeightInspect Sequence and Object Property Values	451
4.4.6 Insert Sequence and Object	452
4.4.6.1 Sequence Wizard for an Insert Sequence	453

4.4.6.2 Insert Sequence	475
4.4.6.2.1 Property setting guidelines for Insert sequence	475
4.4.6.2.2 Details on properties of Insert sequence	478
4.4.6.2.3 Details on results of Insert sequence	483
4.4.6.3 Insert Object	484
4.4.6.3.1 Property guideline for Insert object	485
4.4.6.3.2 Details on properties of Insert object	491
4.4.6.3.3 Details on results of Insert object	496
4.4.6.4 TensileTest Object	498
4.4.6.4.1 Property guidelines for the TensileTest object	498
4.4.6.4.2 Details on the properties of the TensileTest object	501
4.4.6.4.3 Details on the results of the TensileTest object	503
4.4.6.5 Adjustment Guidelines for the Insert Sequence and Object Property Values	504
4.5 SPEL+ Programming of the Force Functions	507
4.5.1 SPEL+ Commands of Force Guide 8.0	507
4.5.1.1 Force object	507
4.5.1.2 Properties	507
4.5.1.3 Status	507
4.5.2 SPEL+ Programming of the Force Control Function	507
4.5.2.1 Overview	507
4.5.2.2 Coordinate System of the Force Control Function	508
4.5.2.3 Parameters of the Force Control Function	508
4.5.2.4 Executing the Force Control Function	509
4.5.3 SPEL+ Programming of the Force Trigger Function	510
4.5.3.1 Overview	510
4.5.3.2 Coordinate System of the Force Trigger Function	511
4.5.3.3 Parameters of the Force Trigger Function	511
4.5.3.4 Executing the Force Trigger Function	512
4.5.3.5 Getting the Results of the Force Trigger Function	513
4.5.4 SPEL+ Programming of the Force Monitor Function	513
4.5.4.1 Overview	514
4.5.4.2 Coordinate System of the Force Monitor Function	514
4.5.4.3 Parameters of the Force Monitor Function	514
4.5.4.4 Executing the Force Monitor Function	515

4.5.5 SPEL+ Programming of the Force Motion Restriction Function	516
4.5.5.1 Overview	516
4.5.5.2 Parameters of the Force Motion Restriction Function	516
4.5.5.3 Executing the Force Motion Restriction Function	517
4.5.5.4 Getting the Results of the Force Motion Restriction Function	518
4.5.6 Example of a Force Function Program	519
4.5.6.1 Pressing Operation	519
4.5.6.2 Sample Program	520
4.5.6.3 Description	521
4.6 Tutorial	523
4.6.1 Common Settings	527
4.6.1.1 Connection Settings for the Force Sensor	528
4.6.1.2 Create a New Project	528
4.6.1.3 Setting the Flange Offset	529
4.6.1.4 Enable a Simulator	530
4.6.1.5 Display the [Force Guide] Window	530
4.6.2 Tutorial Using General Force Guide Sequence	532
4.6.2.1 Force Guidance Function (pressing to vertical-downward)	532
4.6.2.1.1 Sequence wizard	532
4.6.2.1.2 Object(s) Alignment	535
4.6.2.1.3 Property Setting	537
4.6.2.1.4 Position Teaching	540
4.6.2.1.5 Setting Confirmation	542
4.6.2.1.6 Motion by Force Guidance Function	543
4.6.2.1.7 Return to the Non-Contact State	544
4.6.2.1.8 Motion Analysis by Monitor	545
4.6.2.1.9 Advanced Tasks	546
4.6.2.2 Force Guidance Function (USB Connector Insertion)	549
4.6.2.2.1 Sequence wizard	550
4.6.2.2.2 Confirmation of Tool Setting	555
4.6.2.2.3 Position Teaching	557
4.6.2.2.4 Property Setting	560
4.6.2.2.5 Setting Confirmation	563
4.6.2.2.6 Motion by Force Guidance Function	568
4.6.2.2.7 Return to the Non-Contact State	568

4.6.2.2.8 Motion Analysis by Monitor	569
4.6.2.2.9 Advanced Tasks	572
4.6.2.3 Force Guidance Function (Peg In Hole)	573
4.6.2.3.1 Sequence wizard	574
4.6.2.3.2 Tool Setting	579
4.6.2.3.3 Position Teaching	579
4.6.2.3.4 Property Setting	582
4.6.2.3.5 Setting Confirmation	587
4.6.2.3.6 Motion by Force Guidance Function	587
4.6.2.3.7 Return to the Non-Contact State	588
4.6.2.3.8 Motion Analysis by Monitor	589
4.6.2.3.9 Advanced Tasks	594
4.6.2.4 Force Guidance Function (Screw Driving)	595
4.6.2.4.1 Sequence wizard	596
4.6.2.4.2 Confirmation of Tool Setting	601
4.6.2.4.3 Position Teaching	602
4.6.2.4.4 Property Setting	604
4.6.2.4.5 Setting Confirmation	608
4.6.2.4.6 Motion by Force Guidance Function	609
4.6.2.4.7 Return to the Non-Contact State	610
4.6.2.4.8 Motion Analysis by Monitor	611
4.6.3 Tutorial Using System Force Guide Sequence	615
4.6.3.1 Paste Sequence	615
4.6.3.1.1 Confirmation of Tool Setting	616
4.6.3.1.2 Position Teaching	617
4.6.3.1.3 Sequence wizard	620
4.6.3.1.4 Setting Confirmation	634
4.6.3.1.5 Motion by Force Guidance Function	635
4.6.3.1.6 Return to the Non-Contact State	636
4.6.3.1.7 Motion Analysis by Monitor	637
4.6.3.1.8 Advanced Tasks	639
4.6.3.2 ScrewTighten Sequence	640
4.6.3.2.1 Confirmation of Tool and Hand Setting	640
4.6.3.2.2 Position Teaching	644
4.6.3.2.3 Sequence wizard	647

4.6.3.2.4 Setting Confirmation	658
4.6.3.2.5 Motion by Force Guidance Function	659
4.6.3.2.6 Return to the Non-Contact State	660
4.6.3.2.7 Motion Analysis by Monitor	661
4.6.3.2.8 Advanced Tasks	663
4.6.3.3 HeightInspect Sequence	668
4.6.3.3.1 Confirmation of Tool Setting	668
4.6.3.3.2 Position Teaching	669
4.6.3.3.3 Sequence wizard	672
4.6.3.3.4 Setting Confirmation	681
4.6.3.3.5 Motion by Force Guidance Function	682
4.6.3.3.6 Return to the Non-Contact State	683
4.6.3.3.7 Motion Analysis by Monitor	683
4.6.3.4 Insert Sequence	685
4.6.3.4.1 Confirmation of Tool Setting	686
4.6.3.4.2 Position Teaching	688
4.6.3.4.3 Sequence wizard	690
4.6.3.4.4 Setting Confirmation	703
4.6.3.4.5 Motion by Force Guidance Function	704
4.6.3.4.6 Return to the Non-Contact State	705
4.6.3.4.7 Motion Analysis by Monitor	706
4.6.3.4.8 Advanced Tasks	709
4.6.4 Command Version (Simple Pressing)	716
4.6.4.1 Creating a Force File	716
4.6.4.2 Setting the Force Control Object	717
4.6.4.3 Setting the Force Monitor Object	718
4.6.4.4 Teaching the Start Point	719
4.6.4.5 Creating a SPEL+ Program	720
4.6.4.6 Executing the Force Monitor	721
4.6.4.7 Executing the SPEL+ Program	722
4.7 Troubleshooting	724
4.7.1 The Force Sensor is not recognized	724
4.7.2 The output value of the Force Sensor differs from the actual force direction	724
4.7.3 The output value of the Force Sensor differs from the actual force	724
4.7.4 The output value of the Force Sensor changes over time.	724

4.7.5 Abnormality occurs on the Force Sensor	725
4.7.6 You cannot perform the intended motion by the force guide object(s)	725
4.7.7 An error 5546 occurs	725
4.7.8 The robot moves in the opposite direction to the intended direction	725
4.7.9 Contact takes too long	725
4.7.10 The robot does not reach the destination	726
4.7.11 The robot bounces excessively when pressing	726
4.7.12 Certain properties do not appear	726

1. FOREWORD

1.1 FOREWORD

Thank you for purchasing our robot products.

This manual contains the information necessary for the correct use of the Force Guide 8.0.

Please carefully read this manual and other related manuals when using this software.

Keep this manual in a handy location for easy access at all times.

The robot system and its optional parts are shipped to our customers only after being subjected to the strictest quality controls, tests, and inspections to certify its compliance with our high-performance standards. Please note that the basic performance of the product will not be exhibited if our robot system is used outside of the usage conditions and product specifications described in the manuals.

This manual describes possible dangers and consequences that we can foresee. Be sure to comply with safety precautions on this manual to use our robot system safely and correctly.

1.2 TRADEMARKS

Microsoft, Windows, Windows logo, Visual Basic, and Visual C++ are either registered trademarks or trademarks of Microsoft Corporation in the United States and/or other countries. Other brand and product names are trademarks or registered trademarks of the respective holders.

1.3 TRADEMARK NOTIFICATION IN THIS MANUAL

Microsoft® Windows® 10 operating system

Microsoft® Windows® 11 operating system

Throughout this manual, Windows 10 and Windows 11 refer to above respective operating systems. In some cases, Windows refers generically to Windows 10 and Windows 11.

1.4 Terms of Use

No part of this instruction manual may be reproduced or reprinted in any form without express written permission.

The information in this document is subject to change without notice.

Please contact us if you find any errors in this document or if you have any questions about the information in this document.

1.5 Manufacturer

SEIKO EPSON CORPORATION

1.6 Contact Information

Contact information details are listed in the "Supplier" section in the following manual.

Note that the contact information may vary depending on your region.

"Safety Manual - Contact Information"

The Safety Manual is also available at the following site.

URL: <https://download.epson.biz/robots/>



1.7 FOREWORD

This manual contains information necessary for the correct use of the ForceGuide 8.0.

SAFETY PRECAUTIONS

This product is a device intended only for use with Epson robots used in industrial environments, whose purpose is the conveyance and assembly of parts within safely isolated areas. Installation of robots and robotic equipment should only be performed by qualified personnel. Also, make sure to do so in accordance with national and local codes.

Please carefully read this manual and other related manuals when using this software.

Keep this manual in a handy location for easy access at all times.

Meanings of symbols

Warning

This symbol indicates that a danger of possible serious injury or death exists if the associated instructions are not followed properly.

CAUTION

This symbol indicates that a danger of possible harm to people or physical damage to equipment and facilities exists if the associated instructions are not followed properly.

1.8 Training

Before using the Force Guide 8.0, be sure to take our "Force Sensing introduction training". We provide the training periodically or every time we received your request to help our customers understand our products.

The training provides safe and easy operation of the product and helps you to improve productivity of your system. For details of the training, please contact the supplier of your region.

2. Installation

2.1 FOREWORD

2.1.1 Overview of Force Guide 8.0

Force Guide 8.0 is an option product and generic name for the following parts:

- Force Sensor
- Intermediate unit (connects Force Sensor and Robot Controller)
- Cable
- Software

Force Guide 8.0 supports various applications such as Peg In Hole, surface processing, pressing, inspection or teaching. It also allows jogging the robot while checking the output of Force Sensor and assists with shortening the teaching time.

Force Guide 8.0 has the following features.

- Force guidance function
 - Operation using force control function, force trigger function, force monitor function, and force motion restriction function can be created by GUI without using SPEL+ language.
- Force control function
 - Position adjustment is done on the coordinate axis moved by external force independently. (Such as only Z-axis or U-axis)
 - Allows different control characteristics for each axis.
 - Covers tolerances of provided workpieces.
- Force trigger function
 - Keeps monitoring precise force, torque, and their changes.
 - Possible to program the judgments of success and failure regarding force and torque, and the conditional branching with operations in an assigned task.
 - Detects the position of an end of workpiece or protruding and dent position by force and torque monitoring.
 - Detects force or torque abnormalities.
- Force monitor function
 - Displays charts of force, torque, and position information of the robot in different coordinate systems.
 - Saves log files in PC.
 - Read the saved files on the force monitor to analyze them. You can also read several files simultaneously and compare.
 - Utilizes them for shorter optimization time and process management information.
- Force motion restriction function
 - Monitors changes in position and posture.
 - Possible to program the judgments of success and failure regarding position and posture while operating, and the conditional branching.
 - Possible to perform more reliable assembly work by adding position and attitude monitoring during force control operation.
 - Detects position or posture abnormalities.
- Gravity compensation function
 - Minimizes the effect of gravity in the following functions while the orientation changes.
 - Force Control, Force Trigger, and Force Monitor functions.
- Mass/Gravity Wizard
 - Measures the gravity center and the mass of an end effector without CAD data or hand removal.

- Impedance Wizard
Estimates the effect of the Force Control parameters on motion.
- Direct Teach + Touch Jog
Apply force to Force Sensor and move the end effector directly by the hands.

2.1.2 Necessary Basic Knowledge of Epson RC+ 8.0

Force Guide 8.0 is an option used in the Epson RC+ 8.0 environment. Knowledge of the Epson RC+ 8.0 development environment and Epson robots is required to use Force Guide 8.0. This manual is intended for users who have knowledge about the following.

- Concept and use of the Epson RC+ 8.0 project management
- Procedure to create and edit a SPEL+ program in Epson RC+ 8.0
- Procedure to run a SPEL+ program from the Run window
- Basic language structure, functions, and use of SPEL+

First-time users of Epson RC+ 8.0 are required to take an introduction training course provided by Epson.

2.1.3 Training

Before using the Force Guide 8.0, be sure to take our "Force Sensing introduction training". The training provides safe and easy operation of the product. And also helps you to improve the productivity of your system.

2.2 Definition of Terms

- **Position**
Position of an object or a coordinate system in a coordinate system. Expressed using position data (X, Y, Z).
- **Posture**
Posture of an object or a coordinate system in a coordinate system. Expressed using posture data (U, V, W).
- **Position/posture**
Position and posture of an object or a coordinate system in a coordinate system. Expressed using position and posture data (X, Y, Z, U, V, W).
- **Force Sensor**
Sensor made by Epson, which detects the force and torque in six axes in the translation direction (Fx, Fy, Fz) and rotating direction (Tx, Ty, Tz). There are the following three types.

S2503, S2506, S25010
- **Sensor flange**
Part to be mounted between the Force Sensor and the robot wrist flange to mount the Force Sensor to the robot.
- **Flange Offsets**
Offset of the sensor flange. Use the bottom center position of the Force Sensor viewed from the tool 0 coordinate system of the robot as the origin and set the position and posture of the coordinate system so its direction aligns with the Force Sensor coordinate system.
- **Force functions**
Functions using the Force Sensor provided by Force Guide 8.0.
- **Force control function**
Function to control the robot to achieve a given target force and torque using the Force Sensor.
- **Virtual inertia coefficient (Mass)**
Parameter for the virtual mass of the force control function. It impacts the acceleration of the force control function.
- **Virtual viscosity coefficient (Damper)**
Parameter for the virtual viscosity of the force control function. It impacts the speed of the force control function.
- **Virtual elasticity coefficient (Spring)**
Parameter for the virtual spring coefficient of the force control function. It impacts the amount of movement of the force control function.
- **Force trigger function**
Function to detect that the force and torque measured using the Force Sensor reached the set value and branch the process.
- **Force monitor function**
Function to measure the force information detected by Force Sensor and the position information of the robot.
 - **Force information**
Force and torque detected by the Force Sensor.
 - **Position information**
Command positions including the position control and the force control; command positions including only the position control; and the difference of the force control.

Measured data can be saved in the files. You can analyze or compare the saved files by reading them.

- Force motion restriction function
Function to detect that the position and posture of the robot have reached the set conditions and branch the processing.
- Force guidance function
Operation using the force control function, force trigger function, and force monitor function can be created by GUI without using SPEL+ language.
- Force Sensor coordinate system
Coordinate system in which the Force Sensor detects the force. It is a Force Sensor-specific coordinate system. It cannot be changed.
- Force coordinate system
Coordinate system in which the force functions are performed. It is defined by the offset of the currently used tool coordinate system.
- Gravity Compensation
Function to reduce the impact of gravity on the Force Sensor.
- Manually define mass properties
Mass characteristic parameter used for gravity compensation. Set the weight and gravity center position of all objects (hand, workpiece, etc.) mounted to the area closer to the tip than the Force Sensor.
- Gravity Direction
Direction of gravity relative to the robot used for gravity compensation. It is defined by gravity direction vectors (X, Y, Z) in the base coordinate system.
- Force Guide Sequence
It is groupings of force guide objects that are required for operation in specific order. Force guide sequences include general force guide sequences created by arranging arbitrary general object, and system force guide sequences predefined for specific tasks.
Types of system force guide sequence are as follows:

- Paste Sequence
- ScrewTighten Sequence
- HeightInspect Sequence
- Insert Sequence

- Force Guide Object
The following is a group of processes that realizes specific motions used by force guidance function.
Force guide objects include general force guide objects that can be added to sequences you create yourself, and system force guide objects that are arranged automatically within system force guide sequences.

The types of General force guide object are as follows:

- Contact Object
- Relax Object
- FollowMove Object
- SurfaceAlign Object
- PressProbe Object
- ContactProbe Object
- Press Object
- PressMove Object
- Decision Object
- SPELFunc Object

Types of system force guide object are as follows:

Paste Object
 ScrewTighten Object
 ScrewRetighten Object
 HeightInspect Object
 Insert Object
 TensileTest Object

- Force object

A set of properties for each function that is necessary to use the force functions. There are the following types of force objects.

Force control object
 Force coordinate object
 Force trigger object
 Force Monitor Object
 Force motion restriction object

- Force control object

Force object used for the force control function.

- Force coordinate object

Force object for defining the coordinate system in which the force functions are performed.

- Force trigger object

Force object for using the force trigger function.

- Force Monitor Object

Force object for using the force monitor function.

- Force motion restriction object

Force object for using the force motion restriction function.

- Properties

Parameters included in the below. Properties can be set and acquired.

Force guide sequence
 Force Guide Object
 Force object

- Result

It is included in the below and a value that is returned after the execution of force guide sequence or force guide object.

Force guide sequence
 Force Guide Object

- Status

Value included in the force object which is returned after a force function is executed.

- Force File

File in which the force object is stored.

- Force Editor

Graphical user interface (GUI) used to edit the force file. It can be opened from Robot Manager and Project Explorer.

- Force Monitor

Graphical user interface (GUI) used to display the Force Sensor values or position of the robot in graphs.

- Impedance Wizard
Wizard used to adjust the parameters of the force control function.
- Mass/Gravity Wizard
Wizard used to adjust mass properties.
- Rated load
The maximum load to satisfy the specifications of the sensor.
- Overload capacity
The maximum load to retain the sensor accuracy.
- Direct Teach
Function to move the end effector continuously by applying force to Force Sensor.
- Touch Jog
Function to move the end effector for a certain distance by lightly pushing Force Sensor.

2.3 System Overview

When using the Force Sensor, connect the Force Sensor and the Force Sensor Connector with a Sensor cable and a Force Sensor M/I connection cable.

Example of system configuration

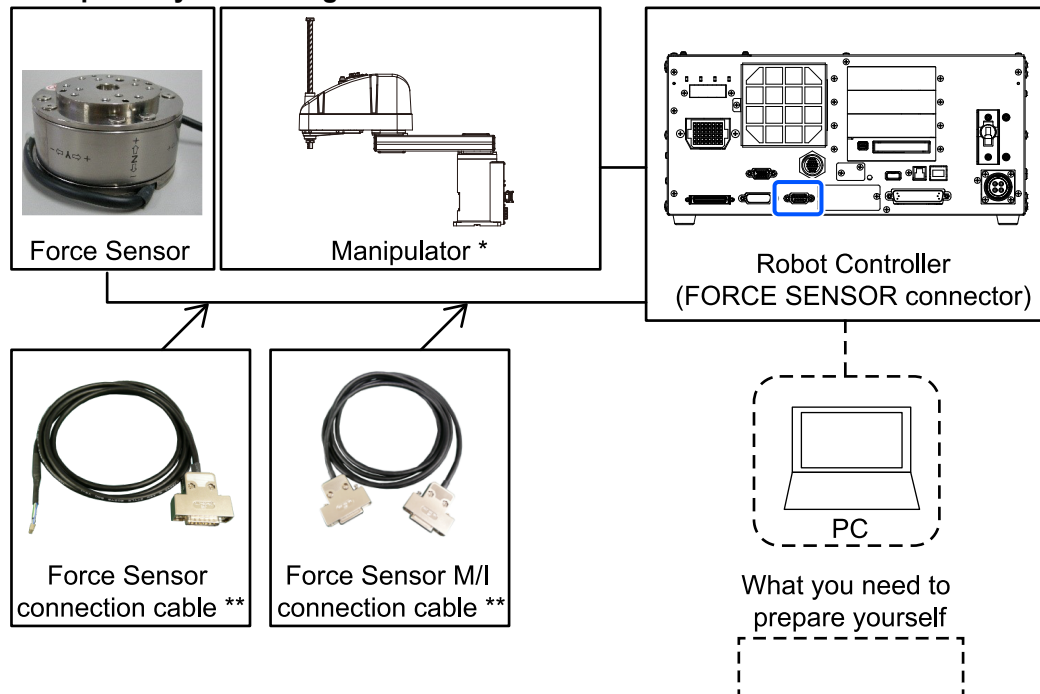

**The shape differs depending on the type of sensor it connects to.

* One from the following:

GX series

2.4 Functions of Force Guide 8.0

2.4.1 Overview

The following describes the main functions provided by Force Guide 8.0.

- Force control function
- Force trigger function
- Force monitor function
- Force motion restriction function
- Force guidance function
- Direct Teach + Touch Jog

CAUTION

Functions provided by Force Guide 8.0 are not functions to ensure safety. To ensure safety, refer to and observe the safety regulations in each country and region.

2.4.2 Force control function

2.4.2.1 Overview of the Force Control Function

A force control function is a function to control the robot to achieve a given target force and torque using an Epson Force Sensor.

Normally, a robot moves to the given target position by position control. The force control function is used to ensure that a target force can be achieved. Furthermore, it enables the robot to perform high precision positioning and Peg In Hole tasks. The force control function can be used in conjunction with normal CP operation commands or it can be used alone.

The force control function is performed in the specified coordinate system and can be performed independently in each of the six axes (X, Y, Z, U, V, and W). Therefore, the force control function can be enabled for all the axes at the same time or only for the specified axis.

Furthermore, since the characteristics of the force control function can be changed for each axis, it can be used for various applications; for example, the pressing operation is performed in an axis, while force is not controlled in another axis.

2.4.2.2 Parameters of the Force Control Function

The following describes the three important parameters of the force control function.

Force control with various characteristics can be performed by changing the following three parameters and target force.

- Virtual inertia coefficient (Mass)

Virtual mass of the force control function. The unit is as follows.

Translation direction (Fx, Fy, Fz): $\text{mN}/(\text{mm}/\text{sec}^2)$

Rotation direction (Tx, Ty, Tz): $\text{mN}/\text{mm}/(\text{deg}/\text{sec}^2)$

The mass parameter impacts the acceleration of the force control function. When the change in force is the same, decreasing the mass parameter increases the acceleration and increasing the mass parameter decreases the acceleration.

- Virtual viscosity coefficient (Damper)

Virtual viscosity of the force control function. The unit is as follows.

Translation direction (Fx, Fy, Fz): $\text{N}/(\text{mm}/\text{sec})$

Rotating direction (Tx, Ty, Tz): N · mm/(deg/sec)

The damper parameter impacts the speed of the force control function. Decreasing the damper parameter increases the speed and the response to changes in force, but may cause the motion of the robot to become vibratory. Conversely, increasing the damper parameter decreases the speed and suppresses the vibration, but decreases the response to changes in force.

- Virtual elasticity coefficient (Spring)

Virtual spring coefficient of the force control function. The unit is as follows.

Translation direction (Fx, Fy, Fz): N/mm

Rotating direction (Tx, Ty, Tz): N · mm/(deg)

The spring parameter impacts the amount of movement of the force control function. Setting the spring parameter provides a virtual spring to limit the maximum amount of movement of the robot. Using this parameter can prevent the robot from interfering with objects around it.

Setting "0" does not limit the amount of movement. When the same constant force continues to be applied, decreasing the spring parameter increases the amount of movement, and increasing the spring parameter decreases the amount of movement.

2.4.3 Force trigger function

A force trigger function is a function to detect that the force and torque measured using an Epson Force Sensor reached the set value and branch the process.

The force trigger function can be used with the following commands.

Command:

Till, Wait, Trap, Find

Using these commands can continue the operation until a certain force is reached or detect changes in force and find an edge or hole on a workpiece. They also can detect excessive force and process the error.

2.4.4 Force monitor function

Force monitor function is a function to measure the force information detected by Epson's Force Sensor and the position information of the robot.

Force information: Force and torque detected by the Force Sensor.

Position information: Command positions including the position control and the force control, command positions only including the position control, and the difference of force control.

The force monitor function can acquire and record forces applied during the operation and measure the average and peak values of the forces.

Measured data can be saved in the files. You can analyze or compare the saved files by reading them.

Using this function can adjust the parameters while creating an application, and record and manage forces applied during the operation for each workpiece.

2.4.5 Force motion restriction function

The force motion restriction function is a function to detect that the position and posture of the robot have reached the set conditions and branches the process.

The force motion restriction function can be used with the following commands.

Command:

Till, Wait, Trap, Find

The followings are performed by this command:

- Reaches the specified position and stops the operation
- Performs more reliable assembly work by detecting changes in position and posture during force control motion
- Detects that the set area has been exceeded and handles the error

2.4.6 Force guidance function

2.4.6.1 Overview of the Force Guidance Function

Force guidance function creates an operation using force control function, force trigger function, and force monitor function without programming by SPEL+ language.

In the force guidance function, operations are created by the force guide sequence and the force guide object.

- Force Guide Sequence
It is like a container in which the required force guide objects are aligned in a specific order to execute a specific operation, or part of one.
- Force Guide Object
You can think of these as specific processes, such as conditional branching, specific motions that include the force control function, and so on.

In the force guidance function, create a specific operation by aligning processes (force guide objects) in a container (force guide sequence). Force guide sequences and force guide objects have the general ones (general force guide sequences and general force guide objects) for users to perform arbitrary actions and tasks. Force guide sequences and force guide objects also have the dedicated ones (system force guide sequences and system force guide objects) for achieving specific tasks.

Force guide sequence and force guide object have properties and results.

- Properties
Property Value that determines the processing of a force guide sequence or force guide object. Depending on the property setting, different motion can be performed even the force guide object is the same.
- Result
Value which indicates the execution result of the force guide sequence or force guide object.

2.4.6.2 Force Guide Sequence

Force guide sequence is like a container that the required force guide objects are aligned in a specific order to execute whole or part of the specific operation.

Force guide sequences consist of general force guide sequences and system force guide sequences.

- General force guide sequence: This sequence is created by adding any general force guide object. Enables user-created operations by arranging force guide objects in sequence. As such, general force guide sequences cannot operate as standalone sequences.
- System force guide sequence: This sequence is used for a dedicated operation. Select the user operation wish to perform and configure in the sequence wizard, then force guide objects are placed automatically based on the settings configured in the sequence wizard. Note that general force guide objects can also be added to a system force guide sequence.

The table below is the list of system sequences:

Name	Description
Paste	Aligns the surface of the held workpiece with the surface of the object and presses it to the specified direction.

Name	Description
ScrewTighten	Tightens screws using an electric screwdriver. After tightening the screws, retightening is also enabled.
HeightInspect	Moves the robot to the specified direction, stops it at the point of contact, measures the height of the object, and inspects it.
Insert	Inserts the workpiece. After inserting a connector, etc., applying force in the direction opposite to the insertion direction to check that the inserted workpiece will not come off is also enabled.

In force guidance function, you can specify the force guide sequence and execute by SPEL+ or GUI.

Property of force guide sequence is a setting that affect to the whole force guide sequence or a process setting when executing the force guide sequence.

Result of force guide sequence displays the result of force guide sequence in [Value].

2.4.6.3 Force Guide Object

It is like a specific process such as a specific motion including force control function or conditional branching.

In the force guidance function, it is not possible to execute by force guide object only. Always execute as the force guide sequence.

Basically, property of force guide object affect to force guide object. However, property setting of force guide object is restricted depending on the setting of previous object. For example, if connecting force control function of two force guide objects, property setting of the second force guide object will be restricted.

Result of force guide object displays the result of force guide object in [Value].

In the force guidance function, you can create the force guide sequence by combining the following ten general force guide objects and 6 system force guide objects that are automatically arranged in system force guide sequence.

General force guide object

- Contact Object

Contact object moves the robot to the specified direction until it contacts with an object such as a workpiece, and stops it when contacting with the object.

This object is used for setting the start position or grasp position of other force guide objects. Even if the workpiece dimension or the grasp position of the workpiece have a margin of error, next motion or the force guide object can be executed stably since the contact position can be detected.
- Relax Object

Relax object moves the robot to a position where the force to the specified direction will be "0".

This object is used for safety releasing of pressing status after pressing by Press object or removal of extra force which is applied during assembly. Also, by combining with the hand motions, this object can follow and grasp. Even if the workpiece dimension or the grasp positions of the workpiece have a margin of error, the robot can grasp the workpiece stably without applying extra force.
- FollowMove Object

FollowMove object moves the robot along with the specified path while following so that the force to the specified direction will be "0".

This object is used for a move of the fixed path of operation targets such as opening/closing the door. In the case of the position control, the operation targets may get damages since extra force is applied if the path moves. However, FollowMove object controls the applied force to be "0". Therefore, the robot can move operation targets without teaching the accurate path.
- SurfaceAlign Object

SurfaceAlign object moves the robot to a position where the torque of the rotation direction will be "0" while the robot presses the workpiece to a specified direction. At this time, the workpiece surface grasped by the robot and the surface of the working desk or the workpiece on the working desk is parallel.

This object is used for positioning during assembly or stable placing of the workpiece. Stable contact status is provided even if the workpiece dimension or the grasp positions of the workpiece have a margin of error.

- **PressProbe Object**

PressProbe object presses the workpiece grasped by the robot to the working desk or a workpiece on the working desk. Then, the robot moves along the specified path and stops when a hole or a convex shape is detected.

This object is used for detection of fitting holes or positioning during assembly. Hole position or a convex shape can be detected stably even if the workpiece dimension or the grasp position of the workpiece have a margin of error. We recommend using this object after the following objects: Contact object SurfaceAlign object Press object.

- **ContactProbe Object**

ContactProbe object moves the robot to the specified direction until it contacts with an object such as a workpiece, and detects a position that is moved for a specified distance as a hole. If the robot contacts with an object without moving the specified distance, returns to the start position and changes the position to repeat the contact motion.

This object is used for the hole position detection of workpiece that is difficult to perform by "PressProbe" such as lead part or connector. Even if the workpiece dimension or the grasp position of the workpiece have a margin of error, the hole position can be detected stably.

- **Press Object**

Press object operates the robot to press to the specified direction with the specified force.

Also, as with Relax object, it is possible to follow another specified direction simultaneously. When executing the Press object without contacting, the robot moves to a direction of the specified force. This object is used for pressing of assembly. Even if the workpiece dimension or the grasp position of the workpiece have a margin of error, the robot can keep a certain force stably.

- **PressMove Object**

PressMove object moves the robot along with the specified path while pressing to the specified direction with the specified force.

Also, as with FollowMove object, it is possible to follow another specified direction simultaneously. When executing the PressMove object without contacting, the robot moves to a direction of the specified force in addition to the specified path. Use this object for pressing, screw driving, or polishing for Peg In Hole or assembly. Even the workpiece dimension or the grasp positions of the workpiece have a margin of error, the robot can move with maintaining the stably force.

- **Decision Object**

Decision object changes the force guide object to be executed based on the results of the objects in the force guide sequence.

This object is used for determination for execution of PressProbe object for Peg In Hole task. This object allows executing the required force guide objects based on the actual motion status of the robot.

- **SPELFunc Object**

SPELFunc object specifies a function in SPEL+ language and executes it.

This object is used when you want to execute functions except the force function such as I/O operations. This object is for advanced-level user.

System Force Guide Objects

- **Paste Object**

A Paste object is a force guide object used to align the surface of the work piece being gripped with the surface of a target object, and press in the direction specified.

You can select whether to perform surface alignment while pressing. Enable this to ensure stable attachment even when there is an error in the workpiece dimensions or workpiece grip position. Paste object success is determined based on success conditions for the force and position set. This object is placed automatically when creating a Paste sequence.

- **ScrewTighten Object**

A ScrewTighten object is a force guide object used to tighten screws using an electric screwdriver that allows for I/O

operations.

When tightening, the screw is pressed in the direction of tightening while following so that the force in the direction perpendicular to the axis of rotation of the screwdriver becomes "0". Screw tightening success is determined based on the screw tightening complete signal from the screwdriver, and success conditions for the position set. This object is placed automatically when creating a ScrewTighten sequence.

- **ScrewRetighten Object**

A ScrewRetighten object is a force guide object that first loosens a screw that was tightened by an electric screwdriver, and then re-tightens it.

This object is executed when a screw tightening complete signal is received from the screwdriver before the screw position reaches the screw tightening success position for the ScrewTighten object. This is useful when the screw gets caught, or is otherwise improperly tightened when tightening screws. Screw retightening success is determined based on success conditions for the position set. This object is placed automatically when screw retightening is enabled in a ScrewTighten sequence.

- **HeightInspect Object:**

A HeightInspect object is a force guide object that moves the robot in a specified direction, stops it upon contact with an object, and measures and inspects the height of the object it has come into contact with.

Measuring the dimensions of the workpieces distributed and the height of the workpiece dimensions after assembly allows you to verify whether assembly work has been performed properly. Height inspection success is determined based on success conditions for the position set. This object is placed automatically when creating a HeightInspect sequence.

- **Insert Object:**

An insert object is a force guide object used to insert a workpiece with a rough tolerance.

When inserting, a pressing force is applied while following so that the force perpendicular to the direction of insertion becomes "0". You can also select whether to follow the force in the direction of rotation. Insertion success is determined based on success conditions for the force and position set. This object is placed automatically when creating an insertion sequence.

- **TensileTest Object:**

A TensileTest object is a force guide object used after the insertion of a connector or similar workpiece to determine whether it can be removed by applying a force in the direction opposite to its direction of insertion.

This object is executed when the success conditions for insertion have been met for an insertion object. TensileTest success is determined based on success conditions for the force and position set. This object is placed automatically when tensile tests are enabled in an insertion sequence.

2.4.7 Direct Teach + Touch Jog

Direct Teach and Touch Jog are functions that apply force to Force Sensor and move the end effector directly by the hands. You can move a robot to the teaching position easily when teaching points. Use the Teach Pendant (TP2, TP4) for operations.

- **Direct Teach**

Function to move the end effector continuously depending on applied force while applying force to Force Sensor. This function is effective for rough positioning. By changing Hardness parameter, you can change the mobility of the robot when applying force. Also, this function can move the robot in the specified direction, so you can move the robot on a straight line or a plane surface.

- **Touch Jog**

Function to move the end effector for a certain distance by lightly pushing Force Sensor. This function is effective for fine positioning. The moving distance can be changed. Only TP2 is available for the operation.

Depending on how to apply force to Force Sensor, Direct Teach and Teach Jog can be executed seamlessly. That is, you can use these functions by applying force to Force Sensor continuously to move the robot to a rough position, then pushing Force Sensor lightly to adjust the robot position accurately.

For details on executing Direct Teach + Touch Jog or changing each setting, refer to the following manuals.

"Robot Controller Option Teach Pendant TP2 - Operation - Direct Teach + Touch Jog"

"Robot Controller Option Teach Pendant TP4 - Direct Teaching of the Force Sensor"

2.5 Robot local

2.5.1 About Coordinate Systems

The following describes the coordinate systems necessary to use Force Guide 8.0; in particular, the Force Sensor coordinate system and force coordinate system. All of the coordinate systems are right handed, and the following coordinate systems are used according to the application.

- **Robot Coordinate System**
Robot-specific coordinate system. This is also called a default base coordinate system (Base) or world coordinate system (World).
- **Local Coordinate System**
User-defined coordinate system positioned in the operation area. (Local)
- **Tool Coordinate System**
Coordinate system of a tool mounted to the sixth joint flange of the robot. [Tool] This is generally also called an end-effector coordinate system.
- **Force coordinate system**
Coordinate system with an offset from the tool coordinate system. [Force] All of the force functions are performed in the force coordinate system.
- **Force Sensor coordinate system**
Force Sensor-specific coordinate system, regardless of the robot. (ForceSensor)

Changes in Position and Posture from Origin to Force Coordinate System

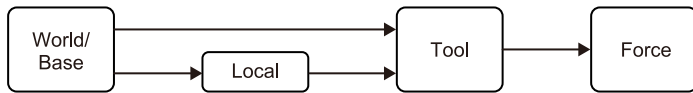

The force coordinate system is impacted by the robot, local, and tool coordinate systems.

For details on the coordinate systems that have an impact on the force coordinate system, refer to the following manual.

"Epson RC+ 8.0 User's Guide"

Example: Coordinate Systems of SCARA Robot

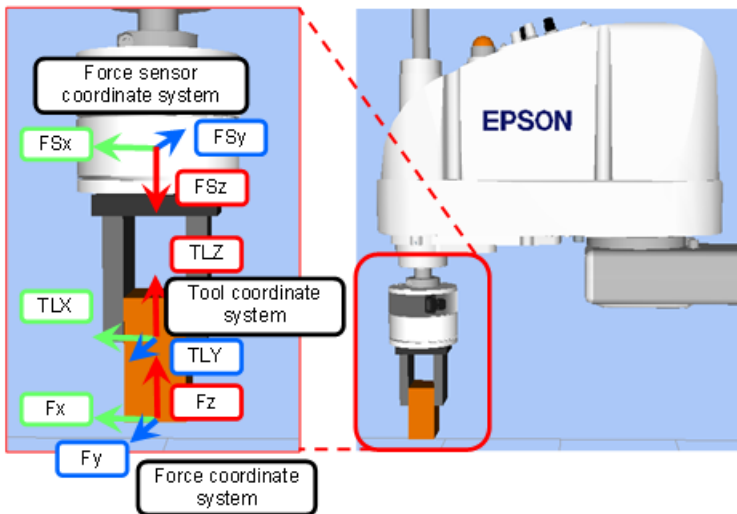

2.5.2 Force coordinate system

A force coordinate system is a coordinate system in which the force functions are performed.

It is defined by translation directions (F_x , F_y , F_z) and rotating directions (T_x , T_y , T_z). T_x , T_y , and T_z represent a clockwise rotation in the positive directions of F_x , F_y , and F_z .

It is defined by the offset of the currently used tool coordinate system. Therefore, moving the robot or changing the tool settings changes the position and posture of the force coordinate system in the base coordinate system. For the force coordinate system, specify a position where a force is actually applied by contact, such as an edge of a workpiece.

- In case of SPEL+ language:

The force coordinate system is defined by the force coordinate object FCS. It is set by the FSet statement or in the Force panel in Robot Manager. The default force coordinate system is a coordinate system that is aligned with the selected tool coordinate system and is defined by FCS0. It cannot be changed.

- In case of force guidance function:

The force coordinate system is defined in the properties of the force guide sequence. It is set on the force guide window.

2.5.3 Force Sensor coordinate system

Coordinate system in which the Force Sensor detects the force.

It is defined by translation F_x , F_y , F_z and axis rotating T_x , T_y , T_z . T_x , T_y , and T_z represent a clockwise rotation in the positive directions of F_x , F_y , and F_z .

It is Force Sensor-specific and cannot be changed. When using the force functions, force values detected in the Force Sensor coordinate system are automatically converted to those in the force coordinate system.

When the Force Sensor and the 6-axis robot are connected using Epson's sensor flange, the Force Sensor can only be mounted to the robot in one way, so if you compare a robot that is mounted on a tabletop to one mounted on a ceiling, its Force Sensor coordinate system will be rotated by 180 degrees around the TLZ axis in the tool 0 coordinate system, provided 0 Pulse is selected for the posture.

2.6 Setting Up Force Guide 8.0

The following describes the setup procedure to use Force Guide 8.0.

To use the force functions and Direct Teach + Touch Jog provided by Force Guide 8.0, perform the following tasks according to the steps shown below.

Force functions and Direct Teach + Touch Jog can be used alternately.

Common with Force functions and Direct Teach + Touch Jog

- 1. Setting up the Robot System
- 2. Checking the accessories
- 3. Mounting and wiring the Force Sensor
- 4. Installing the software
- 5. Setting up the Force Sensor
- 6. Configuring the Force Sensor correction

7-1. Execute force functions 7-2. Execute Direct Teach + Touch Jog

1. Setting up the robot system

Refer to the following manual and set up the robot system.

- Safety Manual
- Epson RC+ 8.0 User's Guide
- Manipulator Manual
- Controller Manual

2. Checking the accessories

Check the parts included in the Force Sensor package. For the details, refer to the following section.

Hardware: [Included Items](#)

3. Mounting and wiring the Force Sensor

Mount the Force Sensor to the robot and connect it with the Controller. For the details, refer to the following section.

Hardware: [How to Install](#)

4. Installing the software

The software of Force Guide 8.0 is included in Epson RC+ 8.0. For the installation procedure, refer to the following manual.

"Epson RC+ 8.0 User's Guide"

5. Setting up the Force Sensor

First link the Force Sensor with the robot. Then, check that the Force Sensor is connected with the Controller correctly and communication is successful. For the details, refer to the following section.

Software: [Checking the Connection](#)

6. Configuring the Force Sensor correction

Configure the settings necessary for Force Sensor correction and check that the sensor values that were corrected correctly

in the force coordinate system can be acquired. For the details, refer to the following section.

Software: **Force Sensor Correction**

7. Execute force functions

Execute each force functions.

Force function can be executed from Force Guidance Function or SPEL+ Program. We recommend using Force Guidance Function.

- Execute force function using Force Guidance Function
Create operations by using force guide sequence and force guide object, then execute each force functions.
For the details, refer to the following section.
Software **Force guidance function**
- Execute force function by using SPEL+ Program
Execute each force functions by using SPEL + Program.
For the details, refer to the following section.
Software: **SPEL+ Programming of the Force Functions**

8. Execute Direct Teach + Touch Jog

Execute Direct Teach and Touch Jog.

Touch jog is only available by TP2.









- For details on executing Direct Teach + Touch Jog using TP2, refer to following manual.
"Robot Controller Option Teach Pendant TP2 - Operation - Direct Teach + Touch Jog"
- For details on executing Direct Teach using TP4, refer to following manual.
"Robot Controller Option Teach Pendant TP4 - Direct Teaching of Force Sensor"



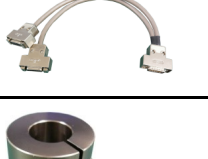
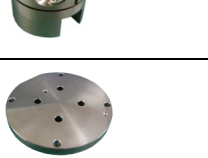

3. Hardware

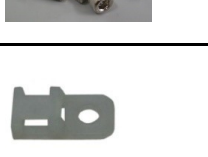
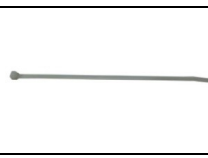
3.1 Included Items

This section describes the items included in the option by product specification.

3.1.1 S2503, S2506, S25010 (for the GX series)

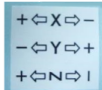
No.	Item	Quantity	Photo
1	Force Sensor (S2503, S2506, S25010)	1	
2	Force Sensor cable (S2503, S2506, S25010)	1	
3	Force Sensor M/I connection cable (S2503, S2506, S25010)	1	
4	Relay cable for external wiring *1 *2	1	
5	Branch cable *1	2	
6	Adapter *3	1	
7	Sensor flange (S2503, S2506, S25010) *4	1	
8	Force Sensor fixing bolts (Hexagon socket cap bolts: M4×15) *4	4	
9	Sensor flange fixing bolts (Hexagon socket head bolts M5×15)	4	
10	Cable mount	2	
11	Wire tie	2	

No.	Item	Quantity	Photo
12	Protection sheet	1	
13	Labels for cables	1	
14	Shaft label for ceiling mount	1	
15	Cable mount fixing screws (Cross recessed pan head machine screws: M4×8)	1	
16	Cable mount fixing bolts (Hexagon socket low head cap bolts: M4×6)	1	

*1 Items 4 and 5 may not be included with shipment depending on the type of option.





*2 Item 4 is included with the GX4 series only. For the G X8, GX10, and GX20 series, it is optional.

*3 Item 6 differs for each Manipulator.

*4 Items 7 and 8 are incorporated in "1. Force Sensor (S2503, S2506, S25010)" at the time of shipment.

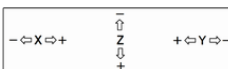
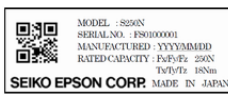
3.2 Label

The following labels are attached to the Force Sensor and Force Sensor I/F unit. Be sure to comply with descriptions and warnings on the labels to operate the Force Sensor safely.

Position	Label	Note
A		Do not loosen or remove the screws on the top face of the Force Sensor. If the screws are loosened or removed, the end effector may come off while the Manipulator is moving or accuracy of the Force Sensor may not be achieved.
B		S2503, S2506, S25010 The coordinate system of the Force Sensor on table top mount Manipulator.
C		S2503, S2506, S25010 Serial number label (Force Sensor)
D		China RoHS label
E		S2503, S2506, S25010 KC label (Force Sensor)
F		CE label
G		UKCA label

Location of the labels

Force Sensor (S2503_S2506_S25010)

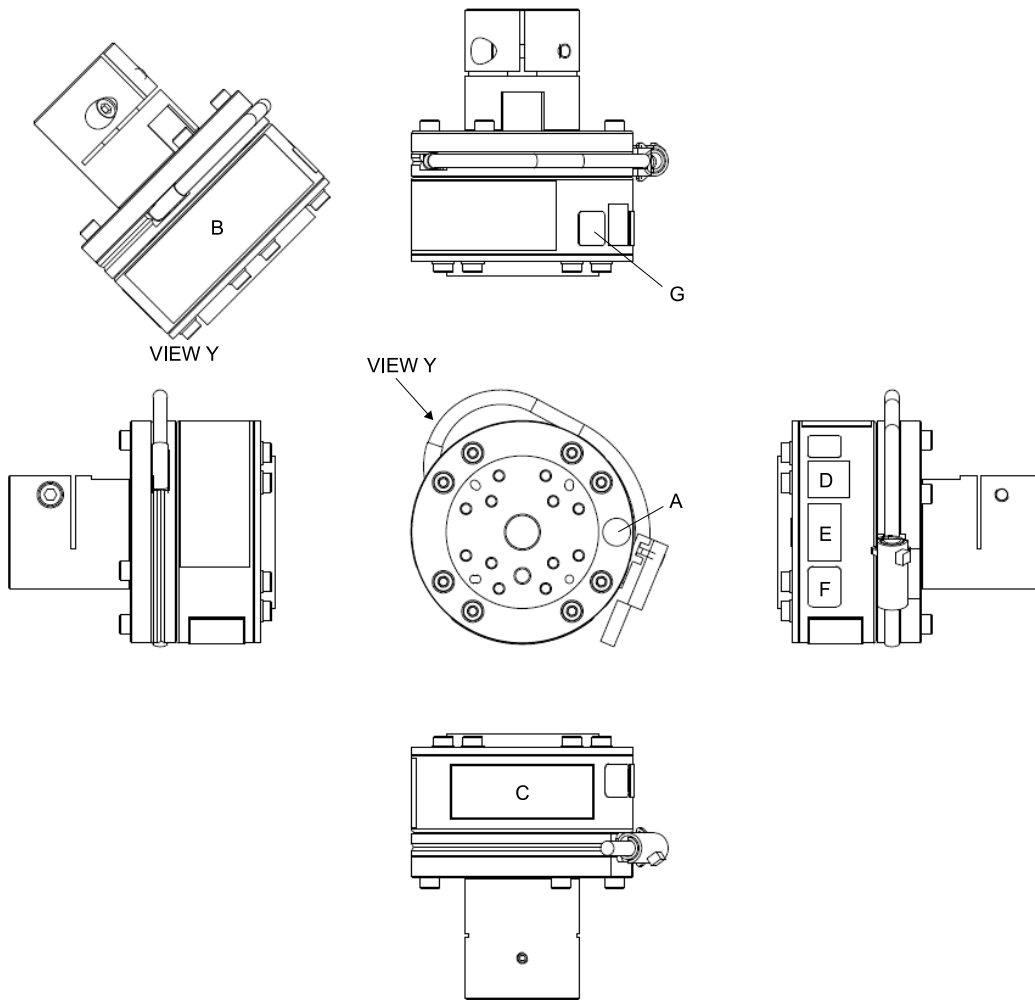

3.3 Connection Example

The following are the connection examples of the robot system and Force Sensor.

Key Point

The following items must be prepared by customers.

- PC for operating the Manipulator

3.3.1 G series, GX series-S2503, S2506, S25010

3.3.1.1 Internal wiring

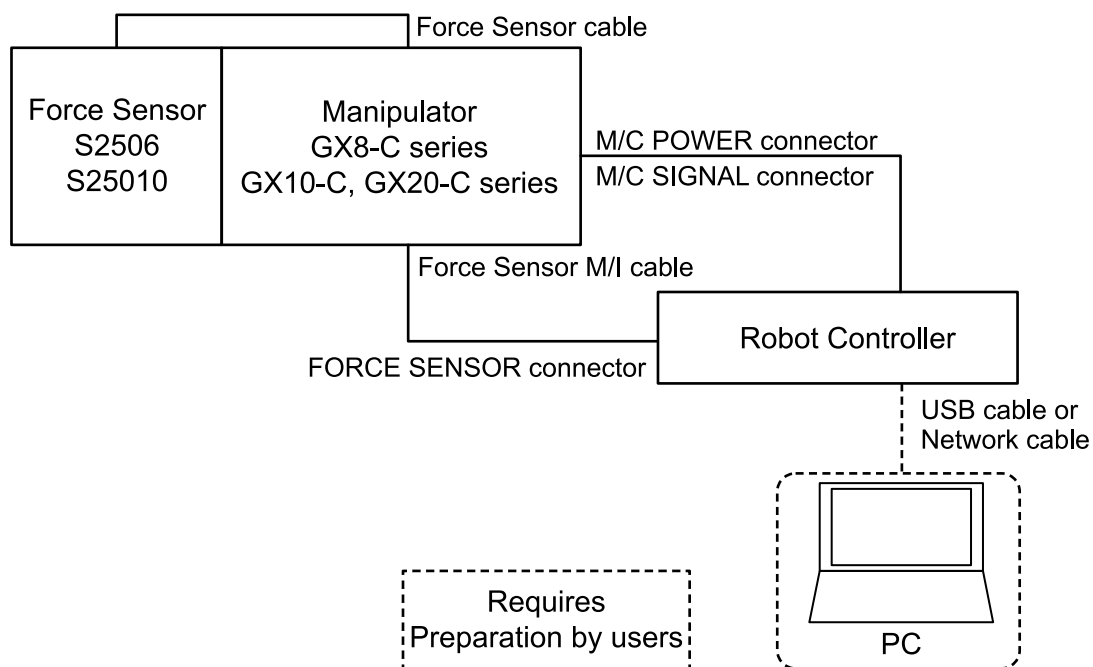

3.3.1.2 External wiring

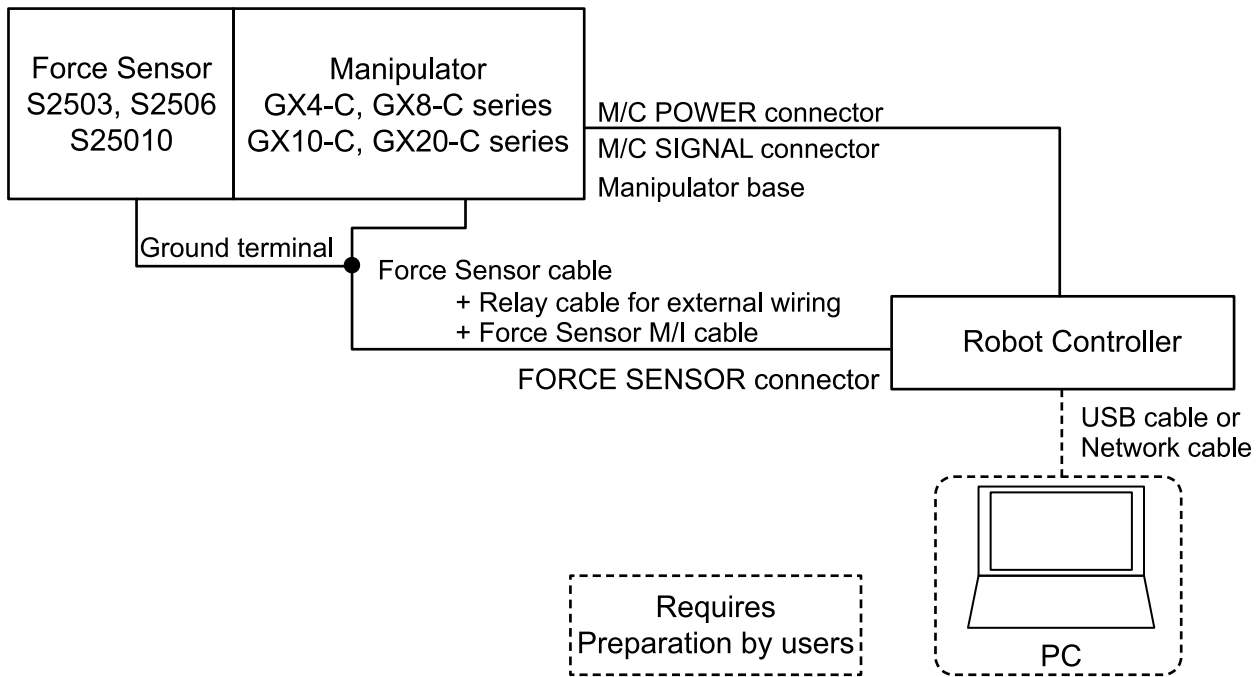

3.4 Force Sensor

⚠ CAUTION

- The allowable load does not guarantee the sensor's performance. The force may not be detected properly if the load exceeding the allowable value is applied. Be sure to use the sensor within the rated load range.
- If the option is used in an environment with rapid temperature change, a drift may increase.

3.4.1 Specification

3.4.1.1 Specification Table

Item	Specification	Remarks		
Outer dimensions	S2503, S2506, S25010 ø80× H52 mm *1	Including the sensor flange Reference: Outer dimensions		
Weight *2	S2503, S2506	620 g		
	S25010	640 g		
Rated load	Fx / Fy / Fz	250 / 250 / 250 [N]		
	Tx / Ty / Tz	18 / 18 / 18 [N·m]		
Overload capacity	Fx / Fy / Fz	1000 [N]		
	Tx / Ty / Tz	36 [N·m]		
Measurement resolution *3	Fx / Fy / Fz	± 0.1 (5 sec, 25 °C) [N]		
	Tx / Ty / Tz	± 0.003 (5 sec, 25 °C) [N·m]		
	Noise level	Fx / Fy / Fz	0.035 [N]	
		Tx / Ty / Tz	0.001 [N·m]	
	Time drift	25 °C	Fx / Fy / Fz	± 0.01 [N/s]
			Tx / Ty / Tz	± 0.0003 [N·m/s]
		40 °C	Fx / Fy / Fz	± 0.02 [N/s]
			Tx / Ty / Tz	± 0.0006 [N·m/s]
Measurement accuracy *4	Fx / Fy / Fz Tx / Ty / Tz	± 5 % RO *5 or less		
Temperature drift	Fx / Fy / Fz Tx / Ty / Tz	0.2 [% / °C] or less compared to 250 [N], 18 [N · m]		

Item		Specification	Remarks
Operating environment	Temperature	- 10 to 40 [°C]	
	Humidity	10 to 80 %Rh no condensation	
Protection rating	IP20	S2503, S2506, S25010	

*1 Sensor height + height to the bottom edge of the sensor flange. When installed with the attached adapter, distance between the Z-axis end face and the sensor end face are as follows:

Reference: **Outer dimensions**

S2503, S2506: 66 mm

S25010: 68 mm

*2 The cable options are not included in the weight.

*3. The measurement resolution, including the noise level and time drift (25 °C), when the measurement time is 5 seconds.

*4. The measurement accuracy when the measurement time is 6 minutes.

*5. RO = Rated Output. This is the accuracy compared to the rated output.

3.4.1.2 ACCEL Setting under Heavy Load

When using the Force Sensor on the following Manipulators, see the following and set ACCEL properly according to the tip load.

Manipulator models: GX10 series, GX20 series

For details of the ACCEL setting and the setting procedures, refer to the Manipulator manuals.

Key Point

Improper setting may cause load exceeding the rated torque for the Force Sensor depending on operation conditions, and may result in the following problem.

Reduction of the life and damage of the Force Sensor

Accel setting value

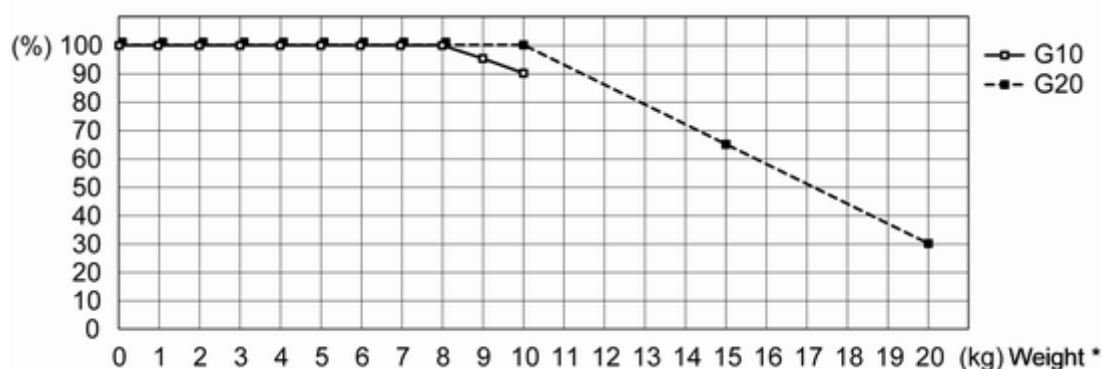

* Weight: Including the weight of the Force Sensor

3.4.2 Outer dimensions

The following are the dimensions of the assembled sensor flange and Force Sensor.

3.4.2.1 S2503, S2506, S25010 (for the GX series)

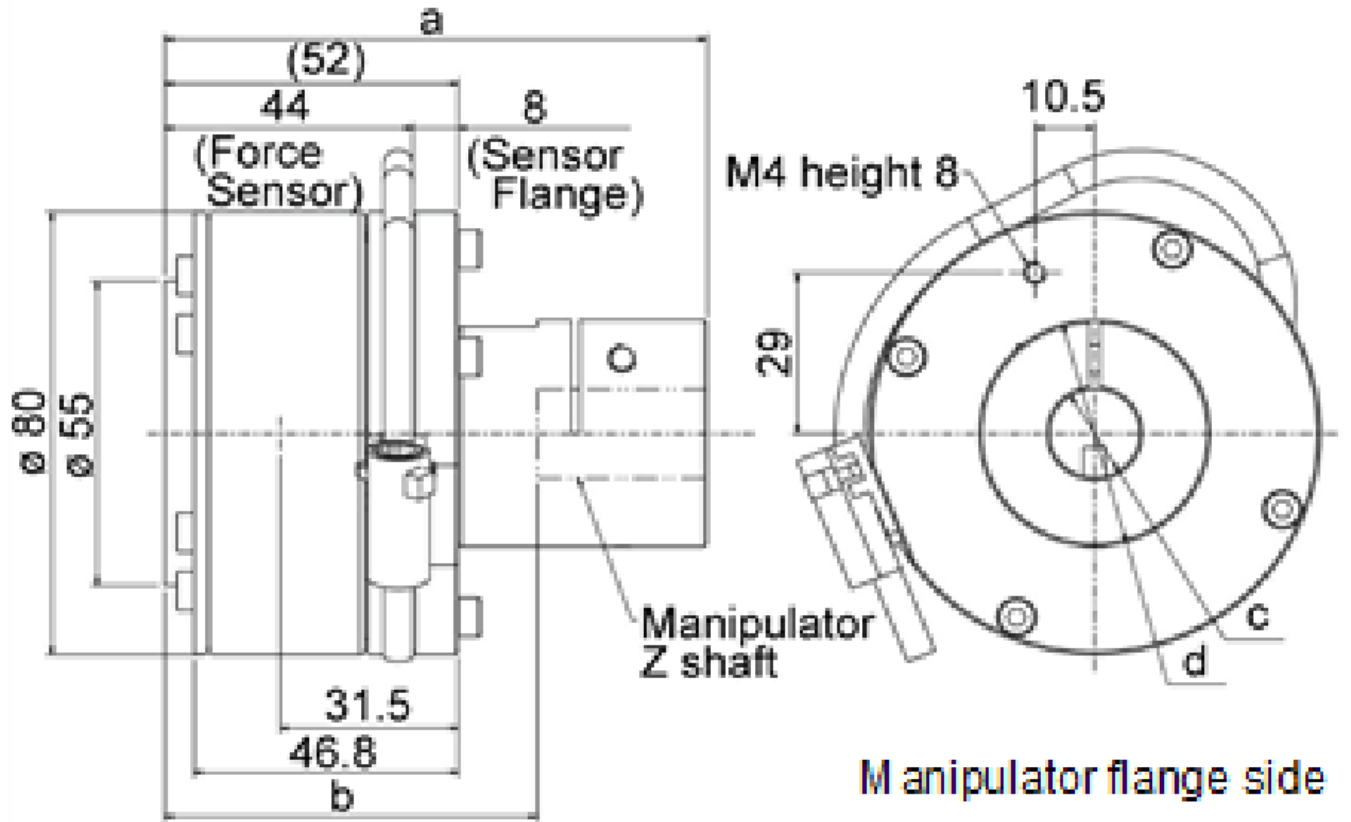

End effector side

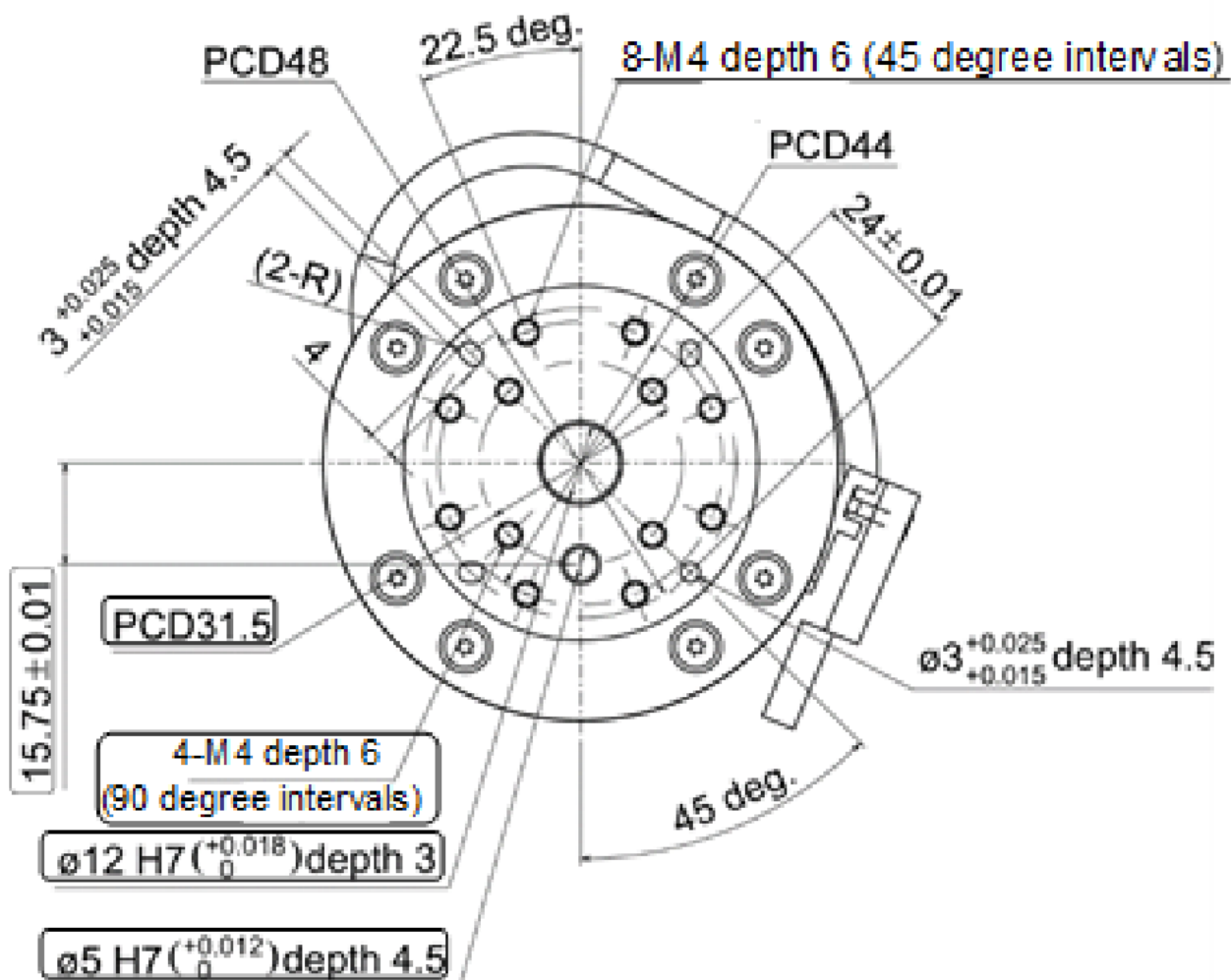

 : Dimension is C4 series Manipulator Flange Compatible Form

(Unit: mm)

		S2503	S2506	S25010
a	Distance from the upper end of the adapter to the end face of the Force Sensor	96		98
b	Distance from the end face of the Manipulator Z-shaft to the end face of the Force Sensor	66		68
c	Diameter of the installation hole for the adapter shaft	16	20	25
d	Outer diameter of the adapter	41		45.5

3.5 How to Install

This section describes how to install the Force Sensor.

Warning

- Before performing any work, turn OFF the Controller and related equipment, and then disconnect the power plug from the power source. Performing any work with the power ON is extremely hazardous and it may result in electric shock and/or improper function of the robot system.
- Be sure to connect the cables properly. Do not allow unnecessary strain on the cables. (Do not put heavy objects on the cables. Do not bend or pull the cables forcibly.) Unnecessary strain on the cables may result in damage to the cables, disconnection, and/or contact failure. Damaged cables, disconnection, or contact failure is extremely hazardous and may result in electric shock and/or improper function of the system.
- Do not touch the sensor circuit board and FFC cables when mounting the Force Sensor. It may result in damage to the cables and connectors, disconnection, and/or contact failure, and may result in electric shock and/or improper function of the system.

CAUTION

- Install the Force Sensor to the Manipulator properly by referring to the following section.

Hardware [Installing the Force Sensor](#)

Installing the Force Sensor in an improper manner may cause accuracy degradation or malfunction of the sensor.

- Install the Force Sensor to the Manipulator with the recommended tightening torque. If the Force Sensor is fixed with an improper torque, it may result in abnormal sensor performance. If the Force Sensor is fixed with the tightening torque lower than the recommended torque, the Force Sensor may fall during the Manipulator operation and may result in damage to the sensor and the system.
- When installing the sensor cables to the Manipulator, fix them so as not to interfere with the Manipulator's operation range.

Also, load may be applied to the cables even in the movable range of the cables and it may cause cable breakage.

3.5.1 Installing the Force Sensor

3.5.1.1 S2503, S2506, S25010 (for the GX series)

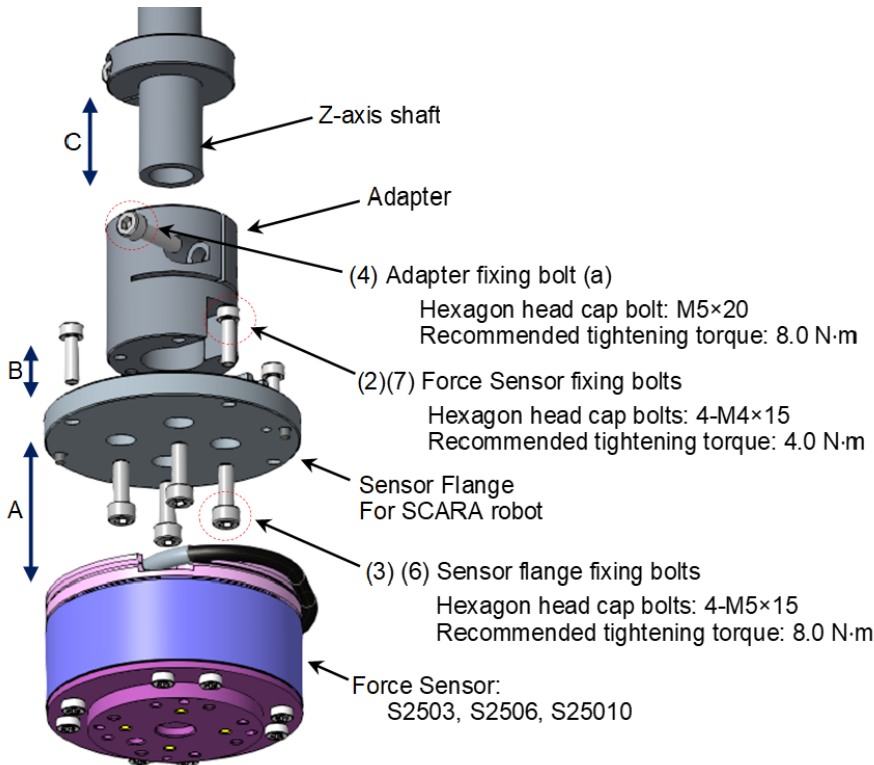

1. Turn OFF the Controller.
2. Remove the sensor flange from the Force Sensor. (A)
Force Sensor fixing bolts (Hexagon socket head cap bolts: 4-M4×15)
(The sensor is fixed to the sensor flange at the time of shipment.)
3. Fix the sensor flange and the adapter (B)
Sensor flange fixing bolts (Hexagon socket head bolts 4-M5×15)
Recommended tightening torque: 8.0 N m
4. Insert and fix the adapter at 30 mm from the end of the Z-axis shaft. (C)
If the Z stopper position has not been changed since the time of shipment, fix the adapter where it touches the Z stopper.
Fix with the following bolts (a) and (b).
Adjust the direction of the bolt (b) so as to touch the D-cut face on the Z-axis shaft vertically.
 - Adapter fixing bolt (a):
Stud clamp bolt (Hexagon socket head cap bolt: M5× 20)
Recommended tightening torque: 8.0 N m

- Adapter fixing bolt (b):
Set screw (Hexagon socket set screw: M4×10)
Recommended tightening torque: 2.4 N m

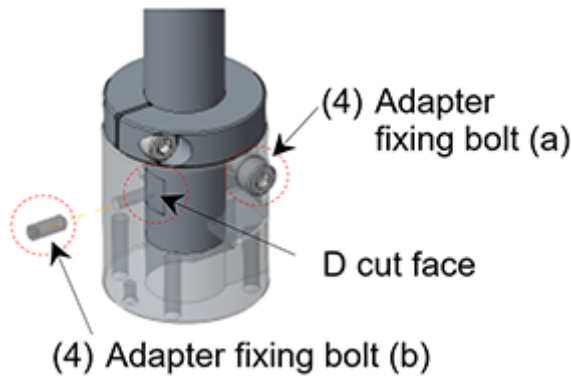

5. Connect the Force Sensor cable to the connector (D) on the Force Sensor.
There are two types of board for the sensor. The installation method varies depending on the sensor. note that
When passing the Force Sensor cable to the Z-axis hollow shaft, follow the following steps.

- (1) Pass the Force Sensor cable through from the upper part of the shaft.
- (2) Pull the cable out through the opening in the adapter.
- (3) Connect the Force Sensor cable to the connector (D) on the Force Sensor.

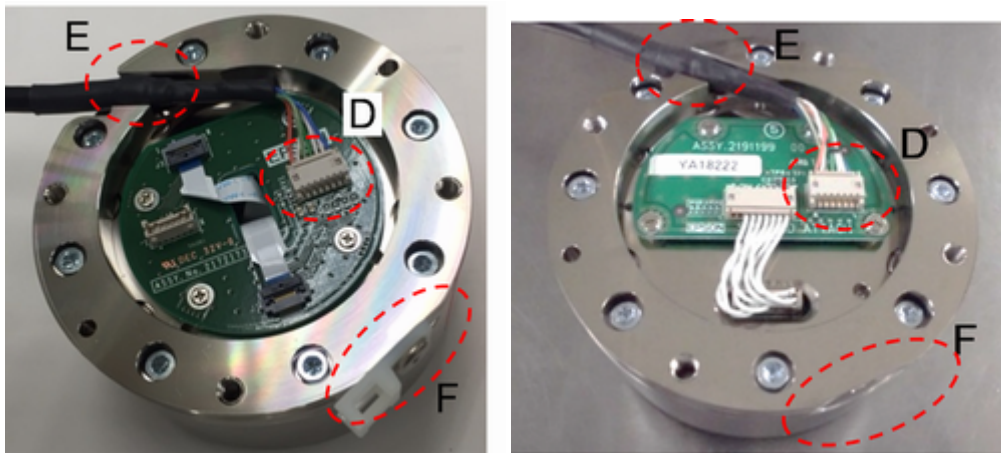

6. Install the Force Sensor on the sensor flange fixed in step 3. (A)Align the cutouts (F) on the sensor flange and the Force Sensor. Insert the sensor flange while inserting the two positioning pins on the sensor flange to the sensor. At this time, adjust the position of the Force Sensor cable so that the part wrapped with the heat shrinkable tube to be at (E).
7. Fix the sensor flange and the Force Sensor with the bolts removed in step 2.
Force Sensor fixing bolts (Hexagon socket head cap bolts: 4-M4×15)
Recommended tightening torque: 4.0 N m
8. Fix the Force Sensor cable to the Manipulator. Set the cable so as not to interfere with Manipulator motion and not to apply load on the cable. For details of cable wiring and grounding, refer to the following section. Hardware [Wiring of the Force Sensor Cable](#)
9. Connect the Force Sensor M/I connection cable to the FORCE SENSOR connector on the controller.

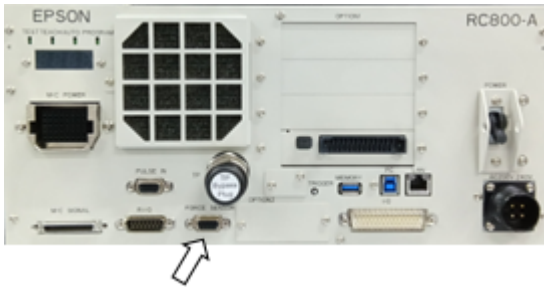

3.5.2 End Effector

The end effector must be fabricated by customers.

 **Key Point**

For details about mounting screw holes position on end effector side, refer to the following section.

[Outer dimensions](#)

 **CAUTION**

- Design the sensor installation face of the end effector so that the sensor can be completely contacted to the end effector. Also, use the end effector with sufficient rigidity in order to achieve high performance of the sensor.
- When operating the Manipulator with the end effector installed, the end effector may collide with the Manipulator body due to following factors.
 - End effector outer diameter /
 - Work piece size /
 - Force Sensor outer diameter/
 - Arm position, etc.

When designing the system, be very careful of interference area of the end effector and Force Sensor.

3.5.2.1 Guidelines of Allowable Moment

The following describes precautions when designing an end effector.

There is an allowable moment on joints of the robot. You need to design the robot not to exceed the limit of the allowable moment of corresponding joints. Allowable moment is calculated as follows.

When the direction of the load and pressing moment are the same:

Moment [N m]

$$= \text{Load mass (mass of the Force Sensor, end effector, and workpiece) [kg]} \times \text{Gravitational acceleration [m/s}^2\text{]} \times \text{axis distance between center of rotation and load's center of gravity [m]} + \text{pressing force [N]} \times \text{axis distance between center of rotation and contact point [m]}$$

When the direction of the load and pressing moment are different:

Moment [N m]

$$= \text{Load mass (mass of the Force Sensor, end effector, and workpiece) [kg]} \times \text{Gravitational acceleration [m/s}^2\text{]} \times \text{axis distance between center of rotation and load's center of gravity [m]} - \text{pressing force [N]} \times \text{axis distance between center of rotation and contact point [m]}$$

3.5.2.2 Guidelines for Joint Torque

When application applies a great force or load of end effector/workpiece is heavy, follow the directions shown below and check the joint torque.

3.5.2.2.1 Check of Joint Peak Torque

PTRQ can acquire or display the peak torque. (Refer to sample program for usage.)

When PTRQ is "1", problems of security may occur. Make sure to check the PTRQ is less than "1".

```

Function PTRQ_Check                                     'Sample program to acquire and display PTRQ
  Integer i
  Double PT(6)
  Do                                                    'Repeat motion part and PTRQ acquisition
part
  PTCLR                                                'Clear the peak torque
  '---Motion part (Example)---Motion part is an example and is described by user
  TLSet 1, XY(0, 0, -49, 0, 0, 0)                    'Set tool 1
  Tool 1                                              'Specify Tool 1
  Motor On                                           'Motor on
  Power High                                         'Power high
  Speed 100                                          'PTP motion speed setting
  Accel 100, 100                                     'PTP motion acceleration setting
  SpeedS 50                                          'CP motion speed setting
  AccelS 500, 500                                    'CP motion acceleration setting

  Go P1                                               'PTP motion to P1
  Go P2 +Z(20)                                       'Move to P2+Z20mm
  Move P2

  FSet FC1.Fz_Enabled, True                          'Enable force control function only for Fz
  FSet FC1.Fz_Spring, 0                              'Spring value is 0
  FSet FC1.Fz_Damper, 10                             'Damper value is 10
  FSet FC1.Fz_Mass, 10                               'Mass value is 10
  FSet FC1.Fz_TargetForce, -50                      'Set the target force of Fz to -50N
  Wait 0.3                                           'Wait for 0.3 s
  FSet FS1.Reset                                     'Reset the Force Sensor
  FCKeep FC1, 10                                     'Run the force control function for 10 s

  Move P2                                            'Move to P2
  Go P2 +Z(20)                                       'Move to P2+Z20mm
  '-----
  For i = 1 To 6                                     'Repeat 1 to 6
    PT(i) = PTRQ(i)                                  'Acquire PTRQ
    Print "PT_J", i, "=", PTRQ(i)                   'Display PTRQ
  Next
Loop
Fend
    
```

3.5.2.2.2 Overload Rate of Joint

OLRate can acquire or display the overload rate. (Refer to sample program for usage.)

OLRate rises when overload is applied on the joints and falls when overload is no longer applied. Stop as servo error when OLRate keeps rising and becomes "1". Make sure that OLRate does not keep rising. In particular, check the OLRate rising amount of one motion cycle is "0".

```

Function OLRate_Check                                 'Program to acquire or display OLRate
  Integer i, j
  Double OLCheck(6), OL(6)
  Do                                                    'Repeat motion part and PTRQ acquisition part
  '---Motion part (Example)--- Motion part is an example and is described by user
  TLSet 1, XY(0, 0, -49, 0, 0, 0)                    'Set tool 1
    
```

```

Tool 1                                'Specify Tool 1
Motor On                              'Motor on
Power High                            'Power high
Speed 100                             'PTP motion speed setting
Accel 100, 100                        'PTP motion acceleration setting
SpeedS 50                             'CP motion speed setting
AccelS 500, 500                       'CP motion acceleration setting

Go P1                                  'PTP motion to P1
Go P2 +Z(20)                           'Move to P2+Z20mm
Move P2                                'CP motion to P2

FSet FC1.Fz_Enabled, True              'Enable force control function only for Fz
FSet FC1.Fz_Spring, 0                  'Spring value is 0
FSet FC1.Fz_Damper, 10                 'Damper value is 10
FSet FC1.Fz_Mass, 10                   'Mass value is 10
FSet FC1.Fz_TargetForce, -50          'the target force of Fz to -50N
Wait 0.3                               'Wait for 0.3 s
FSet FS1.Reset                         'Reset the Force Sensor
FCKeep FC1, 10                        'Run the force control function for 10 s

Move P2                                'Move to P2
Go P2 +Z(20)                           'Move to P2+Z20mm
-----
For i = 1 To 6                          'Repeat 1 to 6
  If j = 1 Then                          'the second cycle or later
    OLCheck(i) = OLRate(i) - OL(i)      'Acquire OLRate rise amount of one motion cycle
    OL(i) = OLRate(i)                   'Acquire OLRate
    Print "OLCheck_J", i, "=", OLCheck(i) 'Display OLRate rise amount of one motion cycle
  Else                                    'For the first cycle
    OL(i) = OLRate(i)                   'Acquire OLRate
  EndIf
Next
j = 1
Loop
Fend
    
```

3.5.2.3 Cautions about Wires and Pipes

Force may be applied to the end effector due to the cable which is connected to the end effector or pulling from the pipes. The Force Sensor also detects this force. This force may have bad influence for the operation. Therefore, fix the cables and pipes to the sensor binding part.

Fix the wires and pipes to the sensor binding part to reduce the influence of elastic force or gravity.

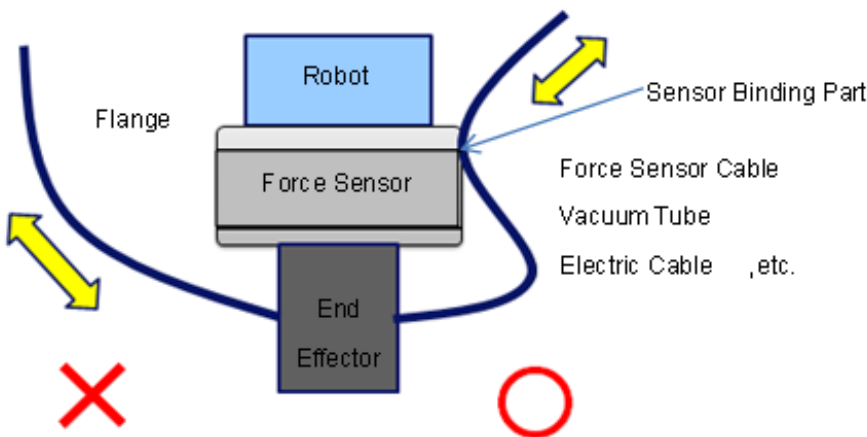

Force or torque will be generated when wires or pipes touch to surrounding objects. Fix the wires and pipes so as not to touch surroundings.

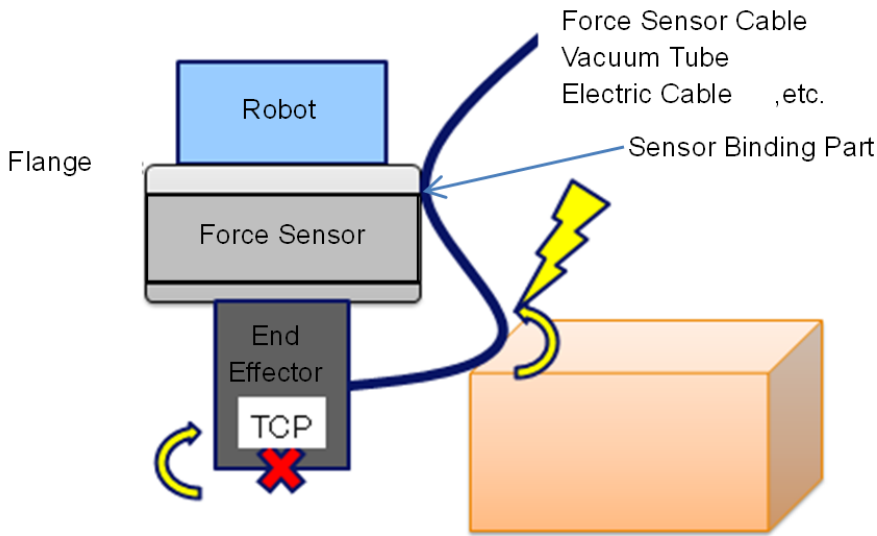

3.5.2.4 Precautions When Handling Heavy Loads or Heavy Objects

When handling heavy loads or heavy objects, the rated load of Force Sensor may be exceeded depending on the operation. Before using, perform a verification in the customer's environment and set the speed and acceleration so that the rated load is not exceeded (Reference: 4. Force Sensor). When the rated load is exceeded during force control operation, the 5548 error will occur.

3.5.3 Wiring of the Force Sensor Cable

The following are recommended wiring examples of the Force Sensor and rough operation ranges of the Manipulator. For actual applications, fix the wiring according to your Manipulator use.

3.5.3.1 GX series-S2503, S2506, S25010

Wiring example 1: When using the D-sub

GX8, GX10, and GX20 series use the user connector D-sub (9-pin) to install the Force Sensor.

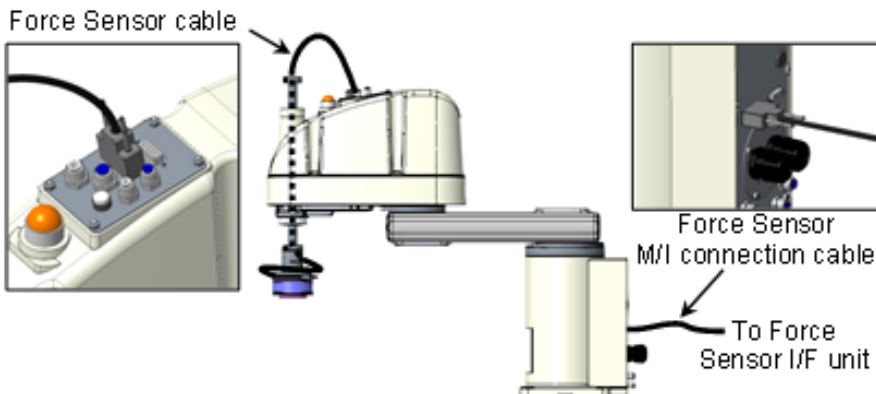

Wiring example 2: When using the cable duct, external wiring option, etc.

For GX4 series, install the cables on the exterior of the Manipulator using the cable duct.

When installing the cables outside the Manipulator, make sure to install the ground wire of the relay cable to the specified position on the Manipulator.

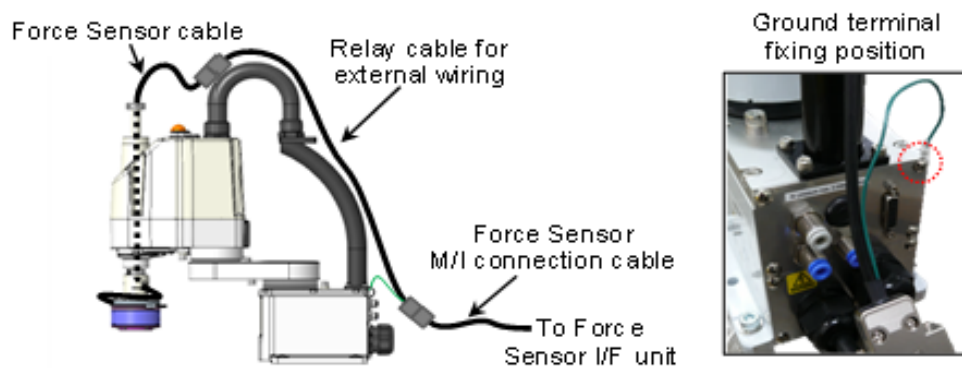

For GX8, GX10, and GX20 series, external wiring is available with the following option products.

Option product		Code	
External wiring unit	GX8-***S	For Table top mounting /standard model	R12NZ901BY
	GX8-***SR/SW	For Ceiling /Wall mounting /standard model	R12NZ901BZ
	GX10/GX20***S	For Table top mounting /standard model	R12NZ900GZ
	GX10/GX20***SR/SW	For Ceiling /Wall mounting /standard model	R12B031912
Relay cable		R12NZ900RW	

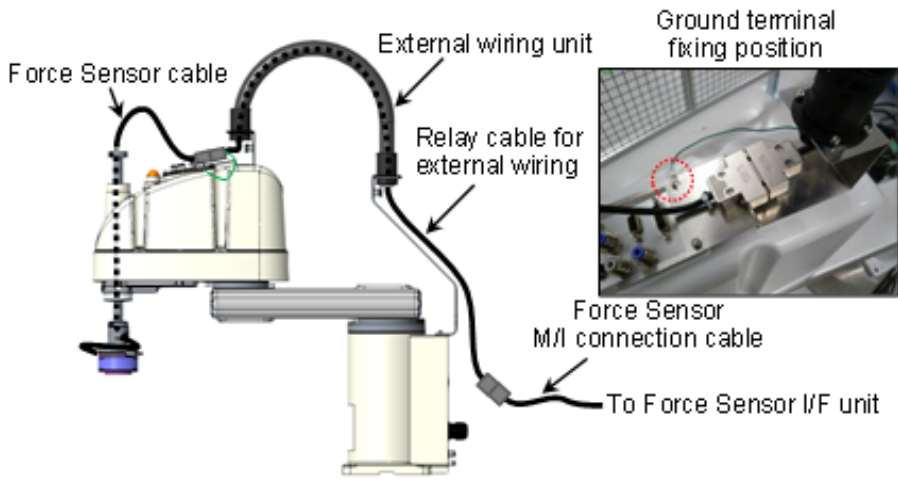

Wiring example 1 and 2 use the attached cable mounts and wire ties for the following fixing parts A and B. For other parts, fix the cables according to the Manipulator motion.

Fixing part A

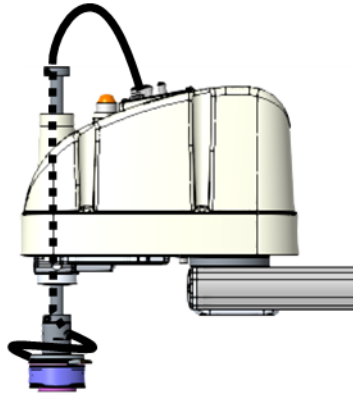
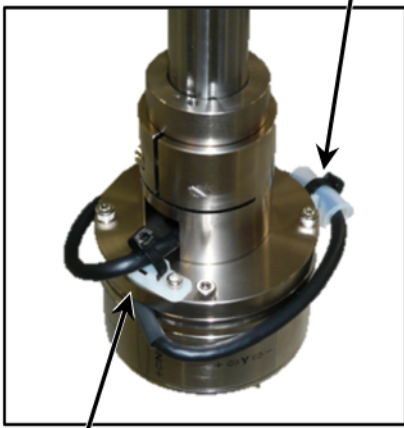

Fixing part B

⚠ CAUTION

- The cables may deform during storage. Caution is required this regard. The cable's bend radius is at least five times larger than the cable diameter (R=30 mm or larger).
- The cable may rub against the Manipulator or get under tension as shown in the photo below depending on the Manipulator motion. When routing the cable, be careful in this regard and check if it touches and rubs against the Manipulator or is under tension.



3.6 Maintenance Parts List

To purchase the maintenance parts listed in this chapter, please contact the supplier of your region.

3.6.1 Force Sensor

Name		Code	Remarks		
For GX series	S2503 S2506 S25010	Force Sensor *1	1673545		
		Sensor flange *3	1701390	SC_FLANGE_PLATE_UNIT	
		Force Sensor cable *4	0.4m	2178628	FSSPC0P4-S250-SCARM-MV-00
			1.2m	2178629	FSSPC1P2-S250-SCARM-MV-00
			1.5m	2178630	FSSPC1P5-S250-SCARM-MV-00
			2m	2178631	FSSPC2P0-S250-SCARM-MV-00
		Force Sensor M/I connection cable *2	3m	2179199	SC_RB-BOX_CABLE_UNIT_3m
			5m	2179200	SC_RB-BOX_CABLE_UNIT_5m
			10m	2179201	SC_RB-BOX_CABLE_UNIT_10m
		Relay cable *4	2m	2178635	FS_RELAY_CABLE-MV-00
	Branch cable *4	0.3 m	2178636	FS_BRANCH_CABLE-00	
	S2503	Adapter *5	1701391	For GX4	
				SC_16ADAPTER_UNIT	
	S2506		1701392	For GX8	
	SC_20ADAPTER_UNIT				
S25010	1701393		For GX10, GX20		
			SC_25ADAPTER_UNIT		

*1 The following parts are not included in the Force Sensor. Force Sensor cable, Force Sensor M/I connection cable, and Sensor flange

*2 A cable label comes with the Force Sensor M/I connection cable.

*3 The following bolts come with the sensor flange. Force Sensor fixing bolts (Hexagon socket head cap bolts 4-M4×15)

*4 The cables used vary depending on the Manipulator.

*5 The following bolts come with the adapter. Adapter fixing bolt (Hexagon socket head cap bolt: M5×20, Hexagon socket set screw: M4×10)

4. Software

4.1 Checking the Connection

⚠ CAUTION

With improper connection setting of the Force Sensor and the robot, the robot moves according to the output of the improperly configured sensor. If the force control function is performed in this state, the force control function may perform an unintended operation. Configure the settings carefully, and first verify the operation and then perform the force control function.

4.1.1 Configuring the Force Sensor Unit

From the tree, select [Controller]- [Force Sensor]-[Sensor*]. Configure the Force Sensor in [System Configuration].

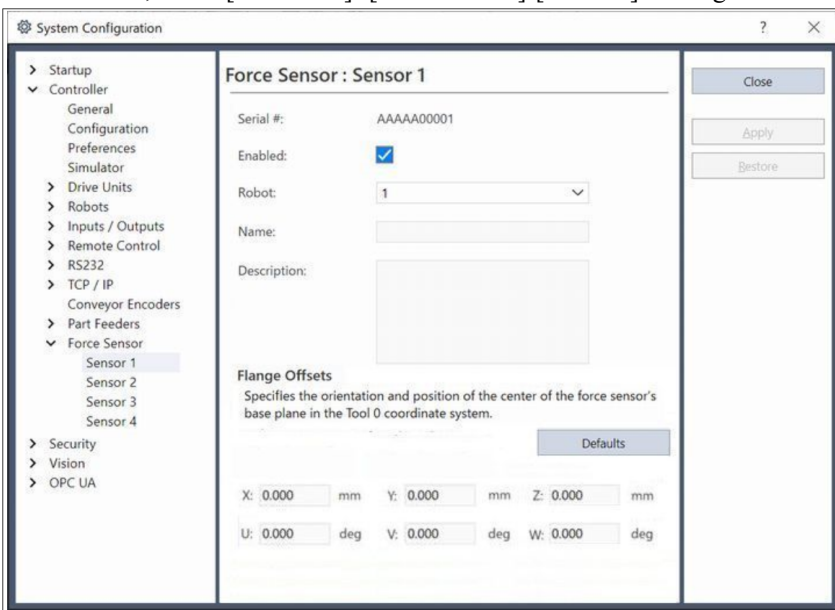

Item	Description
Serial	This is the serial number of the Force Sensor. (up to 10 characters)
Enabled	Set the use of the Force Sensor. Checkbox selected: Gets the force information from the sensor.
Name	Set the name of the Force Sensor. (up to 32 single-byte characters)
Robot	Set the link of the Force Sensor with the added robot. Select the number of the robot to which the Force Sensor is connected.
Description	The user can enter any comments. (up to 255 single-byte characters)
Close	Close the [System Configuration] dialog. Restart the system if the settings are changed.
Apply	Saves the changed values.
Restore	Restores the original values.

4.1.1.1 Force Sensor Connection Procedure

Connect the Force Sensor with the following procedure.

1. Connect the Force Sensor and the Controller with a Force Sensor cable and a Force Sensor M/I cable.
2. Turn ON the Robot Controller.
3. Start Epson RC+ 8.0 and establish a connection with the Robot Controller.
4. From the Setup menu, select [System Configuration].
The [System Configuration] dialog box is displayed.
5. From the tree, select [Controller]-[Force Sensor]-[Sensor 1].
(Select the number of the sensor port of the Force Sensor to which the Force Sensor is connected.)

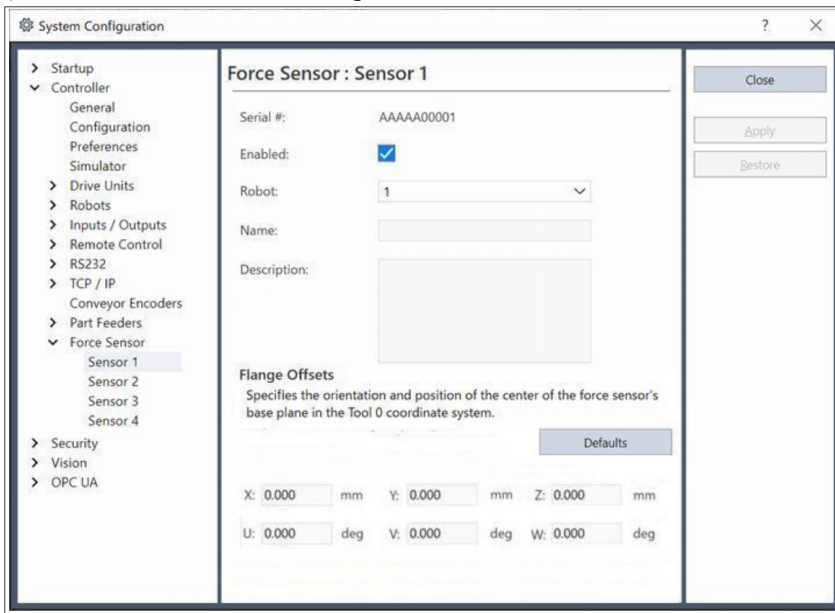

6. Make sure that the Force Sensor has been recognized.
 - Next to [Serial #] the serial code of the connected Force Sensor is displayed.
 - The [Enabled] checkbox should be enabled.
 - In [Robot], select the number of the robot to which the Force Sensor is mounted.
If it has not been properly recognized, check the connections of the Force Sensor cable and the Force Sensor M/I connection cable.
7. Check the flange offset.
The default value may differ depending on the Manipulator.
When you make a sensor flange yourself, measure the offset and set the flange offset.
For details, refer to the following.

Coordinate Conversion

Below are the procedures to follow if you are going to change the settings.

8. Change whichever settings you wish to change.
9. To apply the changes to the settings, click the [Apply] button.
To cancel the changes, click the [Restore] button.
10. Click the [Close] button.
Clicking the button restarts the system and applies the changes to the settings.

4.1.1.2 Force Sensor Disconnection Procedure

Disconnect the Force Sensor with the following procedure.

1. Start Epson RC+ 8.0 and establish a connection with the Robot Controller.
2. From the Setup menu, select [System Configuration].
3. From the tree, click [Controller]- [Force Sensor]- [Sensor 1]. (Select the number of the sensor port of the Force Sensor to which the Force Sensor is connected.)
4. Unselect the [Enabled] checkbox.
5. Click the [Apply] button.
6. Click the [Close] button. The robot controller restarts and the changes to the settings are applied.
7. Turn OFF the Robot Controller.
8. Remove the Force Sensor from the Controller.

4.1.1.3 Force Sensor Replacement Procedure

Replace the Force Sensor with the following procedure.

1. Refer to "Force Sensor Disconnection Procedure" described above and disconnect the Force Sensor.
2. Refer to "Force Sensor Connection Procedure" described above and connect a new Force Sensor.

4.1.2 Checking the Connection

4.1.2.1 Checking the Connection

Check the connection between the Force Sensor and the robot system with the following procedure.

1. Start Epson RC+ 8.0 and establish a connection with the Robot Controller.
2. Check that there is no error.
3. From the Setup menu, select [System Configuration]. Check that tree-[Controller]- [Force Sensor] are displayed.
4. Click [Sensor 1] and check that the serial code of the connected Force Sensor is displayed correctly. (It is the number of the sensor port of the Force Sensor to which the Force Sensor is connected.)
5. If an error does not occur and [Force Sensor] is displayed in the tree, the connection is successful.

If an error occurs, select [System History] from the View menu, identify the error, and take action.

If [Force Sensor] is not displayed in the tree, please check the followings.

- Check the connections of the Force Sensor cable and the Force Sensor M/I connection cable..
- Make sure that neither connector has a loose connection.

4.1.2.2 Checking the Acquisition of Output Values

Perform the following procedure to check that the output values of the Force Sensor can be acquired correctly.

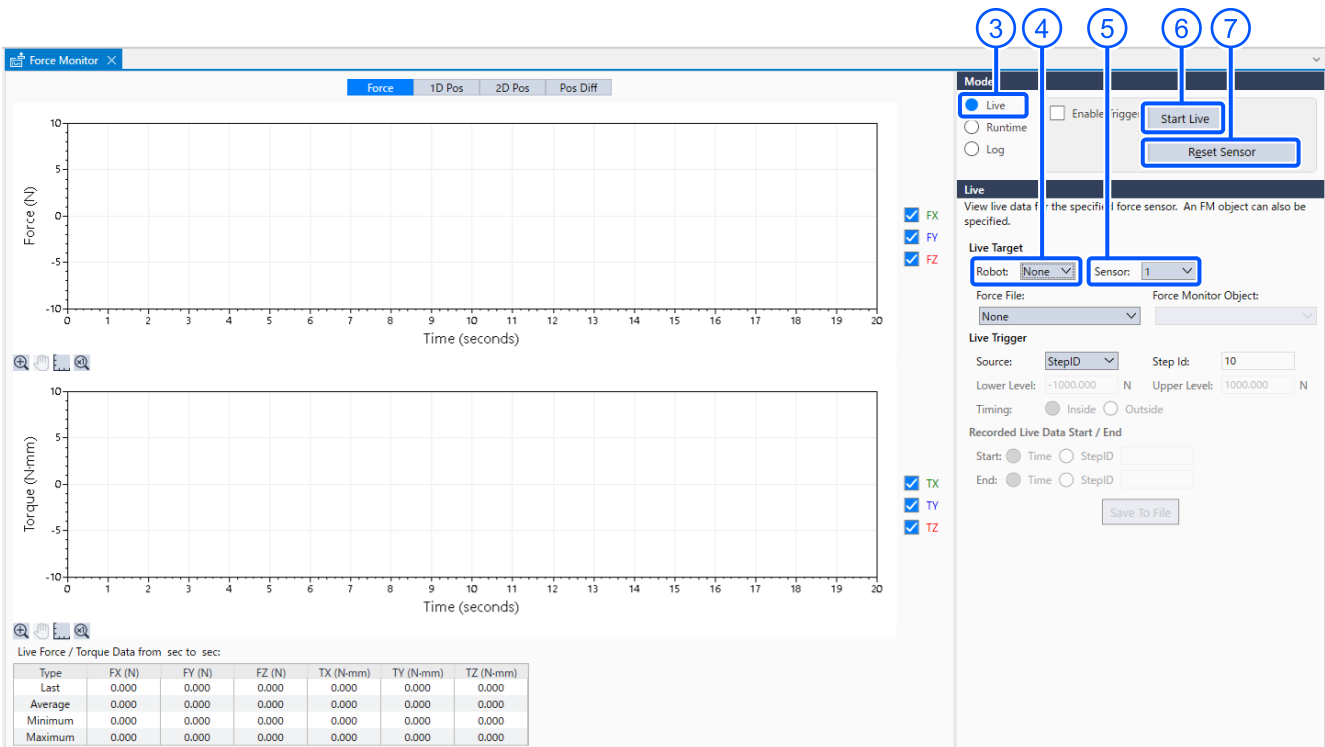

1. Start Epson RC+ 8.0 and establish a connection with the Robot Controller.
2. From the Epson RC+ 8.0 menu, click [Tools]-[Force Monitor].
3. Select [Live] in [Mode].
4. Select "None" in [Live]-[Robot].
5. Select the sensor number to be checked in [Live]-[Sensor]. (The force and torque in the Force Sensor coordinate system are displayed.)
6. Select the [Start Live] button.
7. Click the [Reset Sensor] button.
8. Apply a force along the direction of each axis of the Force Sensor coordinate system and check that the force is detected within the specified accuracy of the Force Sensor.

⚠ CAUTION

When entering the safe guarded area in order to apply a force to the Force Sensor, ensure safety by safety measures such as setting the Manipulator to operation-prohibited status.

For details of safety, refer to the following manual.

"Epson RC+ 8.0 User's Guide"

4.1.3 Checking the Accuracy of the Force Sensor

4.1.3.1 Overview

This section describes a method to check if the Force Sensor is working properly.

Accuracy abnormality may occur if the Force Sensor is damaged by being hit or applied the load which exceeds the rated load. Accuracy abnormality can be checked by comparing the data acquired before use of the Force Sensor (initial data) and the data acquired after the accuracy error was found (comparison data).

If abnormality is found while using the Force Sensor, follow the steps below to check the accuracy of the Force Sensor. When performing the accuracy check, be sure to obtain the initial data before using the Force Sensor.

Accuracy guaranty of the Force Sensor is ±5%. We recommend to replace the Force Sensor if the guaranty value is exceeded when checking the accuracy. However, depending on the applications, some of them are still available if the guaranty value is exceeded. Replace the Force Sensor depending on the usage.

4.1.3.2 Acquisition of the Initial Data

This section describes how to obtain the initial data.

The initial data can be obtained by sample programs on the following pages. This data is used when checking the accuracy of the Force Sensor. Be sure to save the acquired data.

⚠ CAUTION

Change the initial position and motion of the Manipulator according to your usage environment, and make sure that the robot, end effector, cables, and peripherals do not interfere with each other.

```
Function ForceSensorLogSCARA      ' Sample program for SCARA robots
  FSet FM1.Label, "ForceLog"      ' Specifies a label used by the filename.
  Tool 0                          ' Specifies Tool 0
  FSet FM1.CoordinateSystem, FCS0 ' Specifies the Tool coordinate system for the
Force coordinate system
  FSet FM1.ForceSensor, 1         ' Specifies the Force Sensor number
  FSet FM1.LPF_Enabled, False, False, False, False, False, False, False
' Disables a low pass filter
  MP 0                            ' Stops the gravity compensation

Motor On                          ' Motor on
Go AglToPls(0, 0, 0, 0)          ' Moves to the initial position

FSet FS1.Reset                   ' Reset the Force Sensor
FSet FM1.RecordStart, 60, 0.1    ' Starts logging the Force Sensor values
' -----Operation part-----
Motor On                          ' Motor on
' Power High                      ' High power mode
' Accel 50, 50                    ' Acceleration setting
' Speed 50                        ' Speed setting
Wait 2
Go AglToPls (0, 90, 0, 0)
Wait 2
Go AglToPls (0, 90, 0, -90)
Wait 2
Go AglToPls (0, 0, 0, -90)
Wait 2
Go AglToPls (0, 0, -50, -90)
Wait 2
Go AglToPls (0, 0, 0, -90)
Wait 2
Go AglToPls (0, 0, 0, 0)
Wait 2
' -----
  FSet FM1.RecordEnd              ' Finishes logging the Force Sensor values
Fend
```

Description

1. Specify a label. The date and the time of execution are added to the label to form the filename.
Set arbitrary file location and name for the file.
2. Specify Tool 0, and specify the Tool coordinate system for the Force coordinate system.
A user-configured tool can be used. Also, while FCS0 is a Force coordinate system which matches the default Tool coordinate system, user-defined Force coordinate objects can be used .
3. Specify the sensor number.
Specify the sensor number of the Force Sensor that the initial data will be acquired.
4. Disable a low pass filter and stop the gravity compensation.
5. Turn ON the motor, and move the robot to the initial position.
In the sample program, the robot moves to the home position. The robot also can be moved to the user-specified position.
6. Reset the Force Sensor.
7. Start recording the Force Sensor values. The values will be recorded for 60 seconds with 0.1 second intervals.
8. Move the robot to change the Force Sensor's orientation.
In the sample program for SCARA robots, Joints #2, #3, and #4 are moved from the home position to apply an inertia force to the Force Sensor. In order to record the inertia force, the measurement interval for the sensor values is shorter compared to the sample program for 6-axis robots. User-specified motion is also available. Note, however, that 1[N] or more force should be applied in each direction of the sensor from the initial position. In the sample program, the speed and acceleration settings are commented out. Confirm that the motion has no problem and enable the commands.
9. Stop recording the Force Sensor values.

Key Point

Acquired Force Sensor values are affected by the following settings.

- Base coordinate setting (Base)
- Local coordinate setting (Local)
- Tool setting (Tool, TLSet)
- Flange offset setting (F_FlangeOffset)
- Force Coordinate Object (FCS#)

Save the above setting values so that these can be reproduced when acquiring the comparison data.

Key Point

The Force Sensor values are affected by physical installation conditions, such as the tilt of the robot, and shapes and weight of the sensor flange and end effectors. Therefore, be sure to acquire the initial data again when the usage environment changes.

4.1.3.3 Acquisition of the Comparison Data and Comparison with the Initial Data

When the accuracy abnormality of the Force Sensor is found, obtain the comparison data and compare it with the initial data.

The comparison data should be obtained with the same procedure and conditions as the initial data acquisition. Note that the conditions include physical installation environment, setting values, and motion in data acquisition.

If a large difference between the outputs of the Force Sensor is found by comparing the initial data and the comparison data acquired with the same condition as the initial data, the Force Sensor cannot be used.

Accuracy abnormality may occur if the Force Sensor is damaged by being hit or applied the load which exceeds the rated load. Use the Force Sensor within the range of specifications. For details on the specifications, refer to the following section.

Hardware [Specification](#)

4.2 Force Sensor Correction

4.2.1 Resetting the Force Sensor

Epson Force Sensor has drift characteristics. Therefore, it must be reset every time immediately before using the force functions. Use the force functions within 10 minutes after resetting the Force Sensor.

Executing the reset command initializes the Force Sensor and sets the current force and torque to "0". A reset can be performed in the Reset property of the force sensor object.

For details on the Reset property, refer to the following manual.

"Epson RC+ 8.0 Option Force Guide 8.0 SPEL+ Language Reference"

If the Force Sensor is used for a long time without being reset, an error accumulates due to the drift. A Force Sensor error may also occur. note that If the error occurs, executes the Reboot property of the force sensor object.

CAUTION

Be sure to reset the Force Sensor with no external force applied to it. If it is reset with an external force applied to it, the state in which an external force applied is "0". Therefore, if the force applied is removed, the Force Sensor detects a force even if no force is applied. If the force control function is performed in this state, the robot may move unintentionally. Caution is required in this regard.

4.2.2 Coordinate Conversion

Coordinate conversion of the Force Sensor refers to converting the output values of the Force Sensor to the force and torque in the force coordinate system.

All of the force functions are performed in the force coordinate system. Coordinate conversion is always performed automatically.

The force coordinate system can be set by the force coordinate object. The force functions are performed while dynamically switching between the coordinate systems.

Even if the coordinate conversion is used, the output value of Force Sensor does not change. When the output value of Force Sensor has exceeded the rated value, even if the displayed value is within the rated value of Force Sensor, a 5548 error occurs.

CAUTION

If the flange offset or force coordinate object is set incorrectly, the output values of the Force Sensor are converted to the force and torque in a wrong coordinate system. If the force control function is performed in this state, the force control function may perform an unintended operation. Configure the settings carefully, and first verify the operation and then perform the force control function.

Correspondence between the Force Sensor Coordinate System and Tool Coordinate System

To perform coordinate conversion of the output values of the Force Sensor, you need to set the flange offset which means a relative relation between the Force Sensor and the robot.

The physical meaning of the flange offset is the amount of offset by the sensor flange. For the flange offset, use the bottom center position of the Force Sensor viewed from the tool 0 coordinate system of the robot as the origin and set the position and posture of the coordinate system so its direction aligns with the Force Sensor coordinate system.

The offset depending on the robot mounting method using the Epson sensor flange is as follows.

Manipulator model	Sensor model	Mounting type	Flange Offsets (X, Y, Z, U, V, W)
GX4, GX8 series	S2503, S2506	All	(0, 0, -22, 180, 0, 180)
GX10, GX20 series	S25010		(0, 0, -24, 180, 0, 180)

When you make a sensor flange yourself, measure the offset and set the flange offset.

The flange offset can be set in the flange offset can be set in [System Configuration]-[Controller]- [Force Sensor]-[Sensor*] or by the F_FlangeOffset statement. For details on the setting procedure, refer to the following section and manual.

- Software: [\[System Configuration\] menu](#) - [Force Sensor]
- "Epson RC+ 8.0 Option Force Guide 8.0 SPEL+ Language Reference"

Correspondence between the Tool Coordinate System and Force Coordinate System

The force coordinate system is a coordinate system with an offset from the tool coordinate system. Therefore, when the tool tip of the robot moves or the offset of the selected tool coordinate system is changed, the force coordinate system also moves following the movement or change.

The offset of the force coordinate system is set in the force coordinate object.

The origin of the force coordinate system is defined by the offset from the currently selected tool coordinate system using the Position property.

The orientation of the force coordinate system can be selected from the following coordinate systems. The Orientation property is used.

- Base coordinate system
The orientation of the coordinate system is always aligned with the base coordinate system. It does not change even though the posture of the robot or the tool setting is changed.
- Local Coordinate System
At the same time, select the number of the local coordinate system to be used. The orientation of the coordinate system is always aligned with the local coordinate system with the selected number. It does not change even though the posture of the robot or the tool setting is changed.
- Tool Coordinate System
The orientation of the coordinate system is always aligned with the tool coordinate system. It changes according to the posture of the robot or the tool setting.
- Custom coordinate system
The values of the rotating movement from the tool coordinate system are set in U, V, and W simultaneously. The orientation of the coordinate system is the orientation with an offset from the tool coordinate system. It changes according to the posture of the robot or the tool setting.
The force coordinate object can be set in [Force Editor] or by the FSet statement. For details on the setting procedure, refer to the following section and manual.
- Software [\[Robot Manager\] \(Tools Menu\)](#)
- [Tools]-[Robot Manager]-[Force] Panel
- "Epson RC+ 8.0 Option Force Guide 8.0 SPEL+ Language Reference"

4.2.3 Gravity Compensation

4.2.3.1 Overview

Gravity compensation is a function to reduce the impact of the gravity on the Force Sensor.

The Force Sensor measures the difference from "0" that indicates the state of force at the moment the force sensor is reset. Therefore, if the posture of the robot is changed to another posture after resetting the Force Sensor, the Force Sensor also measures the weight of the hand and workpiece impacted by the gravity as the force. As a result, the force control function sometimes cannot perform the intended operation due to this effect. Gravity compensation reduces the impact of gravity from

the measured force to retrieve only the force from an external object that is applied during the intended operation. Even if the gravity compensation is used, Force Sensor is influenced by gravity. When the measured has exceeded the rated value, even if the displayed value is within the rated value of Force Sensor, a 5548 error occurs.

CAUTION

If the setting of the mass property or gravity direction is incorrect or if the mass property number to be used is incorrect, the force control function may perform an unintended operation. Configure the settings carefully, and first verify the operation and then perform the force control function.

4.2.3.2 Manually define mass properties

A mass property object is an object to handle the mass properties for gravity compensation.

The mass property object is an object that has the weight (Mass property) and the center of gravity (GravityCenter property) of all objects (e.g. hand and workpiece) mounted to the area closer to the tip than the Force Sensor. For the weight, set the value including the weight of all objects such as the hand and workpiece, and for the center of gravity, set the gravity center position in the tool 0 coordinate system.

Up to 15 mass property object values can be set for each robot simultaneously. They can be set in the [Mass/Gravity] panel in Robot Manager or by the MPSet statement.

The weight and gravity center position can be set directly in the [Mass/Gravity] panel. They can also be set automatically in Mass / Gravity Wizard for 6-axis robots.

For the details, refer to the following section.

Software [\[Robot Manager\] \(Tools Menu\)](#)

- [Tools]- [Robot Manager]-[Mass/Gravity] Panel

The value of each property can be set directly in the MPSet statement.

For details, refer to the following manual.

"Epson RC+ 8.0 Option Force Guide 8.0 SPEL+ Language Reference"

4.2.3.3 Gravity Direction

Gravity direction is the direction of gravity for the robot necessary for gravity compensation.

The gravity direction is specified by the gravity vector in the base coordinate system of each robot. The robot coordinate system is a coordinate system in which "+z" indicates the upward vertical direction and "+y" indicates the front direction of the robot, and by default, the base coordinate system is also aligned with the robot coordinate system. The gravity works in the downward vertical direction so the gravity direction is represented by the vector (0, 0, -1). This applies to both cases where the robot is mounted to the table and to the ceiling. However, if the base coordinate system was changed using the Base statement, or if the robot is mounted in an inclined state, you need to calculate and set the gravity direction vector in the base coordinate system.

For the gravity direction, set one value for each robot. The gravity direction can be set in the [Mass/Gravity] panel in Robot Manager or in the F_GravityDirection statement.

The values of the gravity direction can be set in the [Mass/Gravity] panel. Furthermore, the gravity direction can be set automatically in Mass / Gravity Wizard for 6-axis robots.

For the details, refer to the following section.

Software [\[Robot Manager\] \(Tools Menu\)](#)

- [Tools]- [Robot Manager]-[Mass/Gravity] Panel

The values of the gravity direction can be set in the F_GravityDirection statement.

For details, refer to the following manual.

"Epson RC+ 8.0 Option Force Guide 8.0 SPEL+ Language Reference"

4.2.3.4 Executing Gravity Compensation

Gravity compensation is always performed for the Force Sensor that is linked with the robot. Gravity compensation cannot be performed for a Force Sensor that is not linked with the robot. Furthermore, selecting the object to be used from the stored mass property objects allows you to select a parameter according to the operation state at any time. Object selection is performed in the MP statement. After executing the MP statement, reset the Force Sensor in the Reset property of the Force Sensor object.

Example: When performing gravity compensation using Mass Property 1

```
MP 1
```

For details on the MP statement, refer to the following manual.
 "Epson RC+ 8.0 Option Force Guide 8.0 SPEL+ Language Reference"

When performing the force control in each of the states where there is a workpiece and where there is not a workpiece, set the mass property in each of the states since a workpiece has also a weight, and perform the force control while switching between both states.

Selecting number 0 (MP0) or selecting the mass property object with a weight of "0" stops the gravity compensation function. If the gravity compensation is not required for operations where, for example, the posture change is small, select "MP0" to stop the gravity compensation. Selecting a mass property object other than "MP0" after stopping it restarts the gravity compensation.

The selected mass property number and set mass property are retained after the Robot Controller is turned OFF until they are changed. Turning ON the Robot Controller also automatically starts the gravity compensation.

4.2.4 Checking the Gravity Compensation Operation

The following describes the procedure to check the Force Sensor correction operation.

- Setting the force coordinate object
- Setting the force monitor object
- Checking that the coordinate conversion is correct in Force Monitor
- Setting the mass properties and gravity direction
- Checking that the gravity compensation is correct in Force Monitor

1. Setting the Force Coordinate Object

- (1) From the Epson RC+ 8.0 menu, click [Tools]-[Robot Manager]. The [Robot Manager] dialog box appears.
- (2) Select [Force] to display the panel.

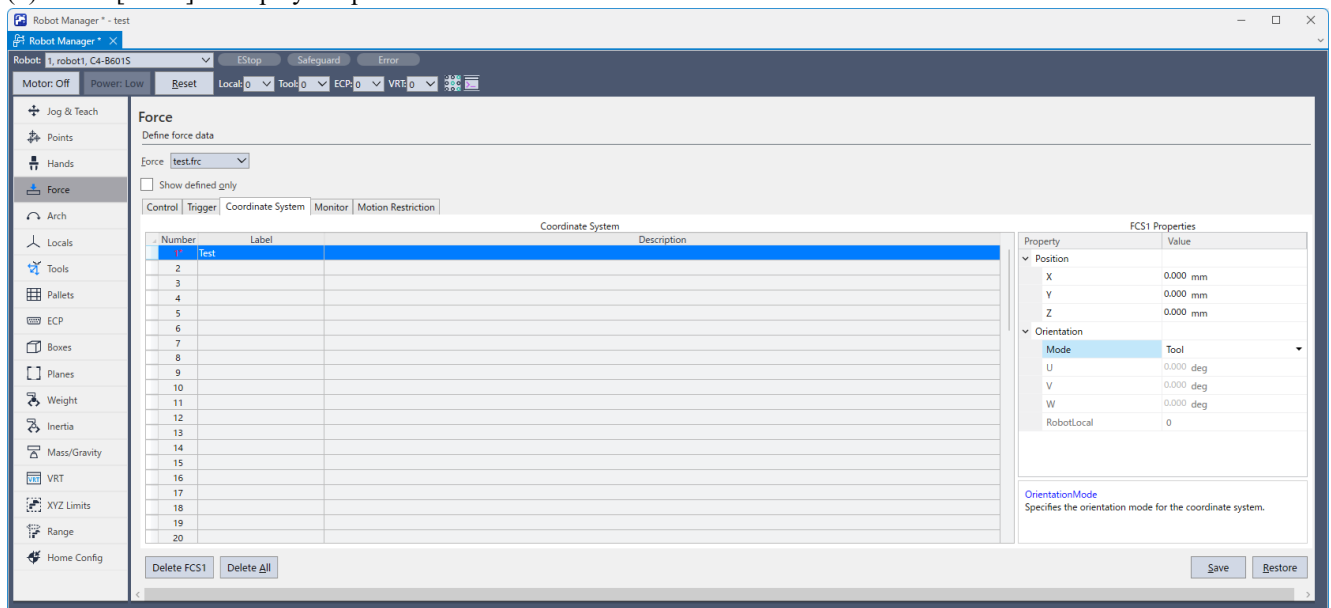

If the force file is not created, the [Force] panel does not appear. If the panel does not appear, refer to the following section

to create a force file.

Software: [New File]- **[File] menu**

(3) Select the [Coordinate System] tab.

(4) In the [Position] property of any force coordinate object, set the origin position of the force coordinate system viewed from the tool coordinate system.

(5) In the [Orientation] property of any force coordinate object, set the orientation of the force coordinate system.

(6) Click the [Save] button to save the changes.

2. Setting the Force Monitor Object

(1) From the Epson RC+ 8.0 menu, click [Tools]-[Robot Manager]. The [Robot Manager] dialog box appears.

(2) Select [Force] to display the panel.

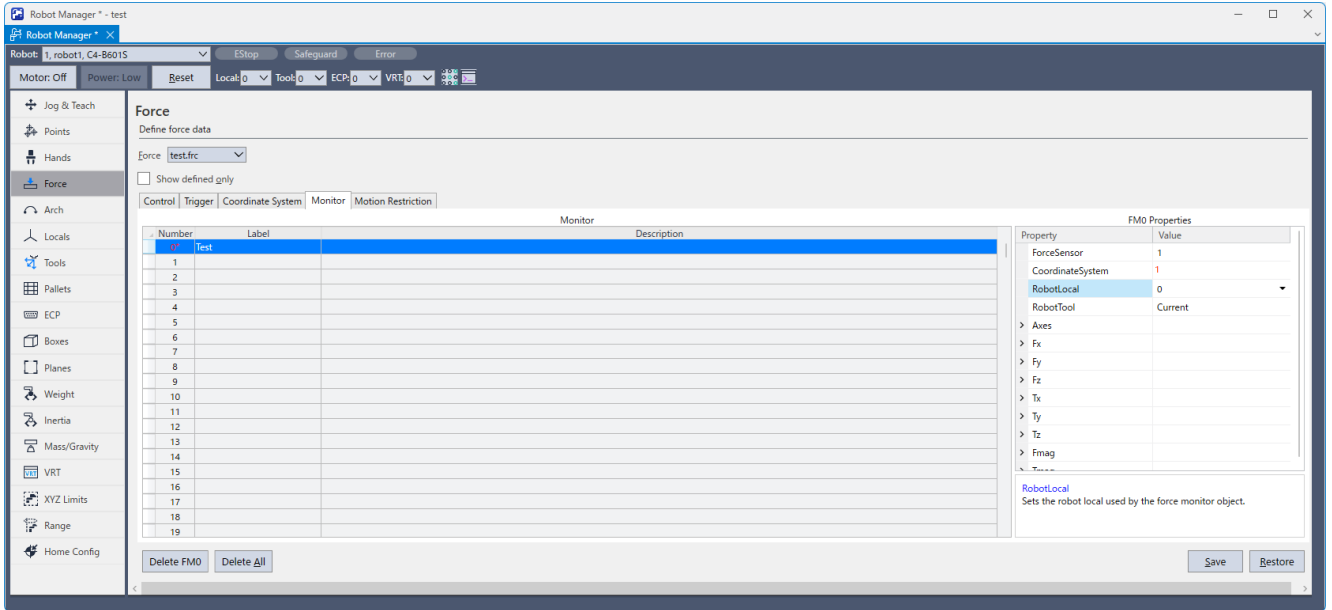

(3) Select the [Monitor] tab.

(4) Specify the Force Sensor number to be used in the [ForceSensor] property of any force monitor object.

(5) In the [CoordinateSystem] property of any force monitor object, specify the force coordinate system object number of the created force coordinate system.

(6) Click the [Save] button to save the changes.

3. Checking that the Coordinate Conversion is Correct in Force Monitor

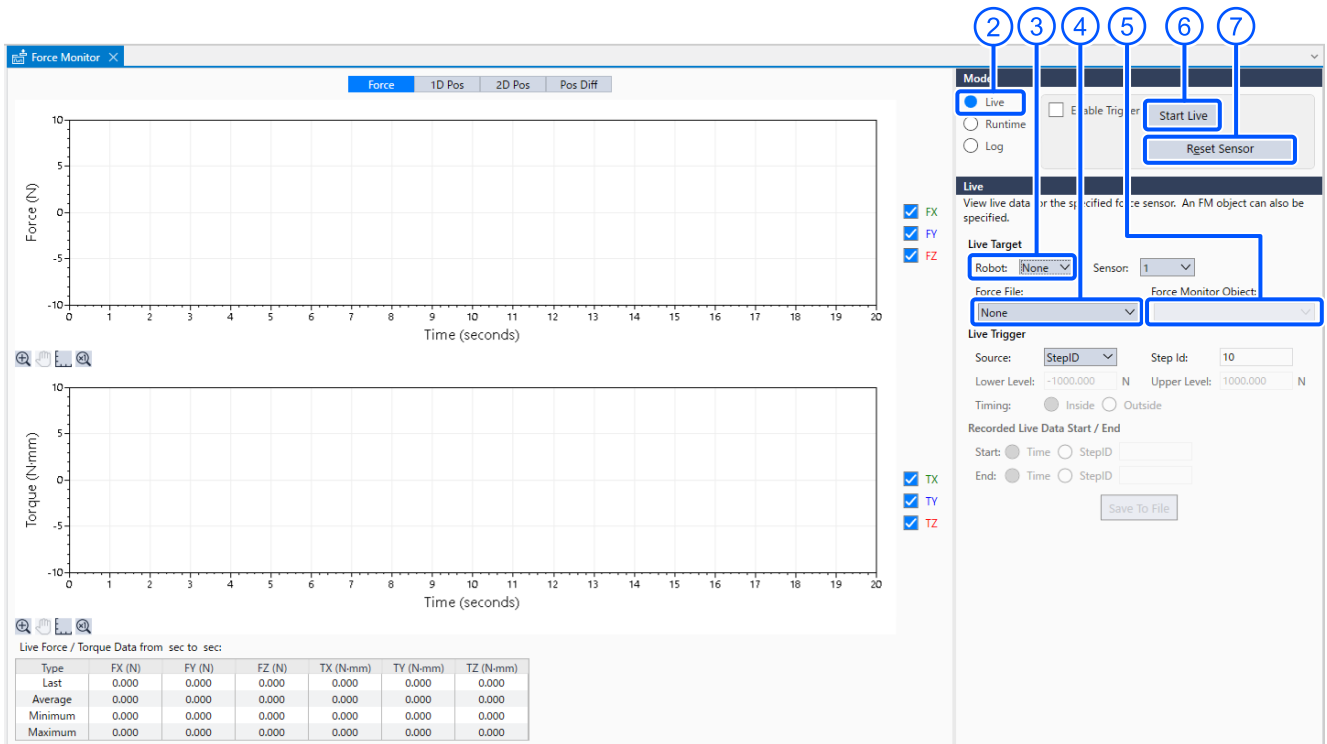

- (1) From the Epson RC+ 8.0 menu, click [Tools]-[Force Monitor].
- (2) Select [Live] in [Mode].
- (3) Select the robot to be checked in [Live]-[Robot].
- (4) In [Live]-[Force File], select the force file by which the force monitor object was set.
- (5) In [Live]-[Force Monitor Object], select the set force monitor object. If the set force monitor object cannot be selected, check whether the force file is correct and the set ForceSensor property is correct.
- (6) Select the [Start Live] button.
- (7) Click the [Reset Sensor] button.
- (8) Apply a force in each of the axis directions in the set force coordinate system to check that the force detected is within the specified accuracy of the Force Sensor.

If the force is not detected in the set force coordinate system, review the following settings.

- Flange Offset, Base, Tool, Local
- Force Coordinate Object, Force Monitor Object

CAUTION

When entering the safe guarded area in order to apply a force to the Force Sensor, ensure safety by safety measures such as setting the Manipulator to operation-prohibited status.

For details of safety, refer to the following manual.

"Epson RC+ 8.0 User's Guide"

4. Setting the Mass Properties and Gravity Direction

- (1) From the Epson RC+ 8.0 menu, click [Tools]-[Robot Manager]. The [Robot Manager] dialog box appears.

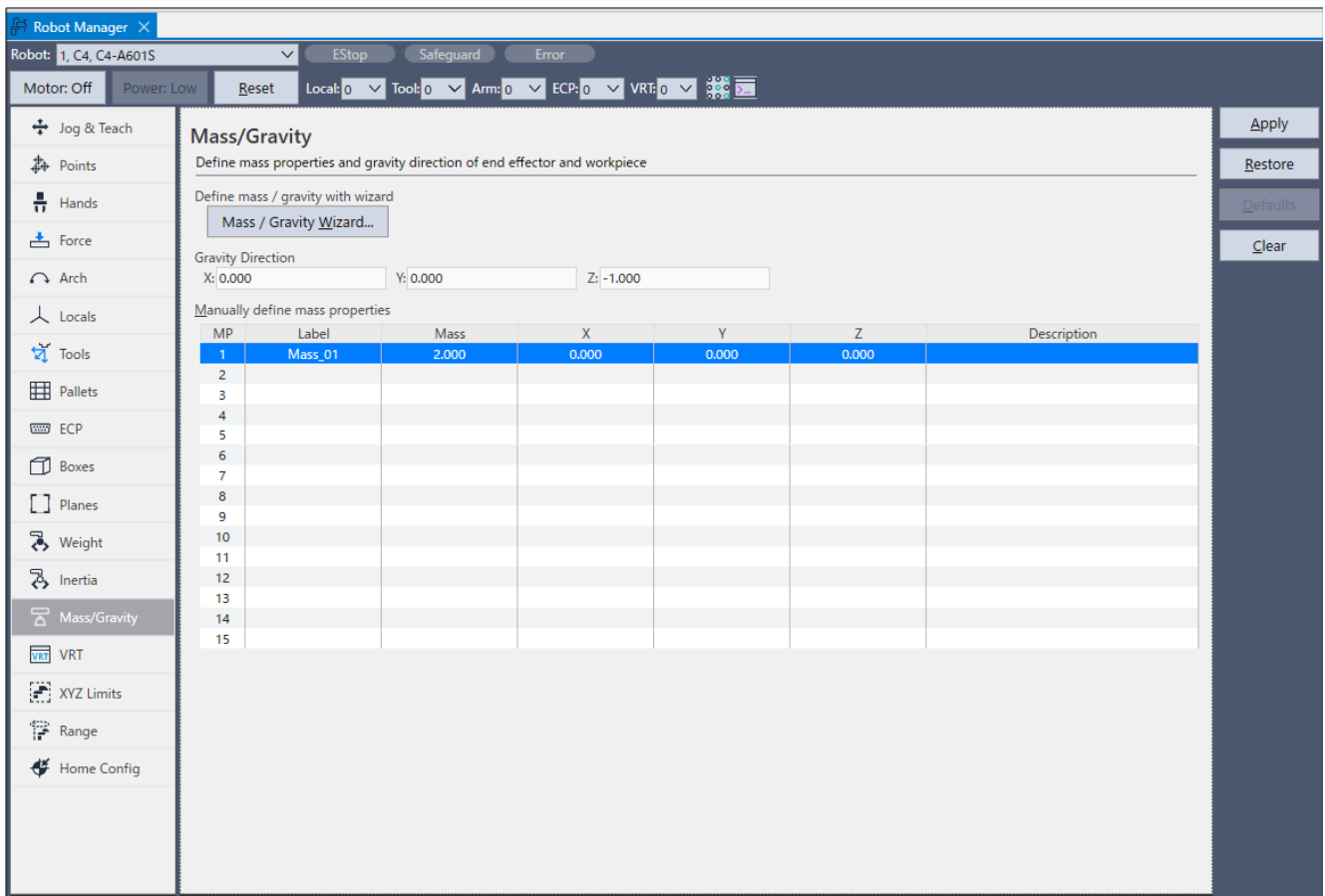

- (2) Select [Mass/Gravity] to display the panel.
 - (3) Enter the mass property and gravity direction with one of the following methods.
 - Directly enter the values in [MP] and [Gravity Direction].
 - Click the [Mass/Gravity Wizard] to run the wizard.
 - (4) Click the [Apply] button to save the settings.
5. Checking that the Gravity Compensation is Correct in Force Monitor
- (1) From Epson RC+ 8.0 menu, click [Tools]-[Command Window].
 - (2) Execute the MP statement and specify "MP0" to stop the gravity compensation.
 - (3) In the [Force Monitor] dialog box, click the [Reset Sensor] button.
 - (4) From Epson RC+ 8.0 menu, click [Tools]-[Robot Manager].
 - (5) Select the [Jog & Teach] panel.
 - (6) In Force Monitor, perform the jog operation while measuring the Force Sensor values to change the posture of the robot. Make sure that the robot does not come in contact with surrounding objects and no force from external objects is applied. No external force is applied, but since the gravity compensation is stopped, the sensor may be affected by gravity depending on the posture and detect a force.
 - (7) Execute the MP statement and specify the set mass properties.
 - (8) In the [Force Monitor] dialog box, click the [Reset Sensor] button.
 - (9) In Force Monitor, perform the jog operation while measuring the Force Sensor values to change the posture of the robot. When the gravity compensation works correctly, the absolute sensor value decreases compared with when the gravity compensation is stopped. However, when the robot is operating, a force actually generated by an increase or decrease in speed may be detected as a Force Sensor value. If there is no change from when the gravity compensation is stopped or the absolute Force Sensor value is larger, identify the set mass properties, and check that the gravity direction is correct and the set mass properties are selected.

4.3 Force Guide 8.0 Graphical User Interface (GUI)

The following describes the Force Guide 8.0 graphical user interface (GUI) that was added to the Epson RC+ 8.0.

- Project Explorer
- [File] menu
- [Edit] menu
- [Project] Menu
- [Tools] menu
- Force Editor
- [System Configuration] menu

Please also read the following manual. "Epson RC+ 8.0 User's Guide"

4.3.1 Project Explorer

4.3.1.1 Force File

Project force files are added in the [Force Control] tree in Project Explorer.

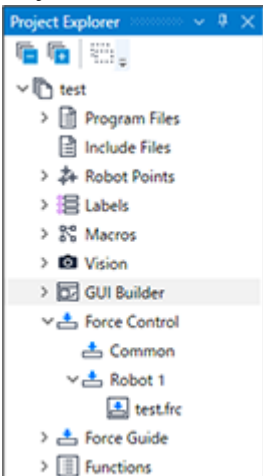

Double-click [Force Control] to display the [Force Editor] window.

For the details, refer to the following section.

Software **Force Editor**

Right-click [Force Control]-[Common] or item under the [Force Control] to display the following context menu of the force file.

Menu Item	Description
New File	Creates a new force file. For the details, refer to the following section. Software: [New File] [File] menu
Existing File	Opens an existing force file.
Open	Displays the [Force Editor] window to edit the force file. For the details, refer to the following section. Software Force Editor
Set Default	Sets the target force file as the file to be loaded when the project is loaded.

Menu Item	Description
Exclude From Project	Set the target force file not to be used in the current project. The excluded force file will not be deleted. If you want to add it to the project once again, select the target force file from [Existing File] menu. Removes a force file from the current project and deletes it.
Delete	Removes a force file from the current project and deletes it.
Rename	Renames the force file.

4.3.1.2 Force Guide

[Force Guide]-[Sequences] are added to Project Explorer.

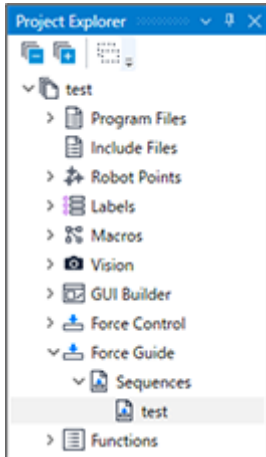

Double-click the sequence in [Force Guide]-[Sequences] to display the [Force Guide] window. For the details, refer to the following section.

Software [Force Guidance] **[Tools] menu**

Right-click the sequence in [Force Guide]-[Sequences] or item under the [Sequences] to display the following context menu that operates Force Guide. **

Menu Item	Description
New File	Creates a new force guide sequence. For the details, refer to the following section. Software [Force Guidance] [Tools] menu - Create a new force guide sequence
Existing File	Opens an existing force file.
Open	Displays the [Force Guide] window to edit the selected force guide sequence. For the details, refer to the following section. Software [Force Guidance] [Tools] menu
Delete	Deletes the selected force guide sequence from the current project. For the details, refer to the following section. Software [Force Guidance] [Tools] menu - Delete Force Guide Sequence

4.3.2 [File] menu

A force file in the current project can be manipulated in Epson RC+ 8.0 - menu-[File].

4.3.2.1 [New File] (File Menu)

 : Ctrl + N

Adds a new force file to the current project.

Select "Force" in [File Type] to display the force files in the project folder in [Existing Files].

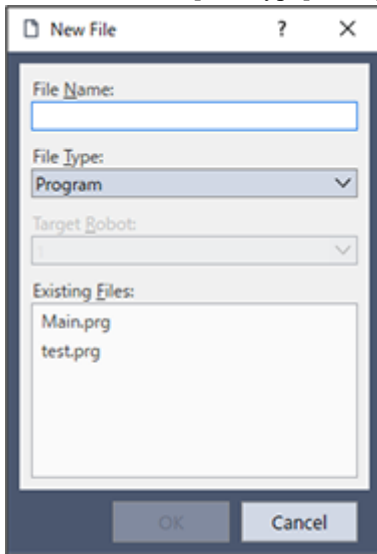

4.3.2.2 [Open File] (File Menu)

 : Ctrl + O

Opens at least one force file to be edited in the current project.

Select the [Force] button to display a list of the force files in the current project.

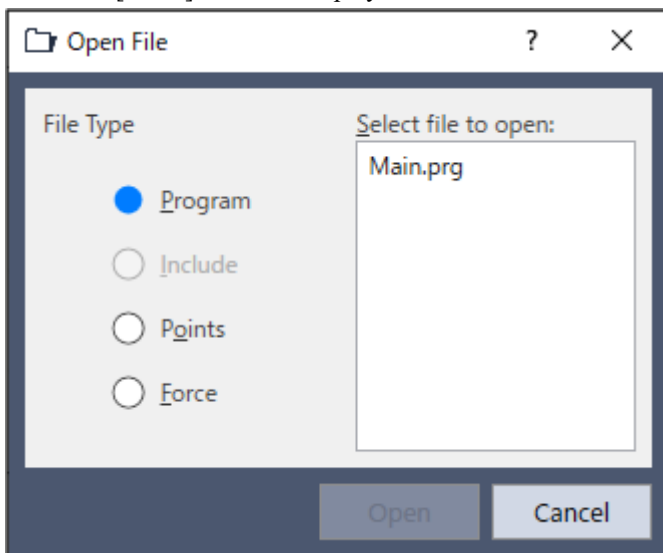

4.3.2.3 [Close File] (File Menu)

Ctrl + D

Closes the window of a force file or a force guide being edited.

4.3.2.4 [Save File] (File Menu)

Ctrl + S

Saves the latest file to the disk.

4.3.2.5 [Save As] (File Menu)

Saves a force file under a new name and adds it to the project.
The original file is removed from the project but remains on the disk.
You can use alphanumeric characters and underscore marks [_].

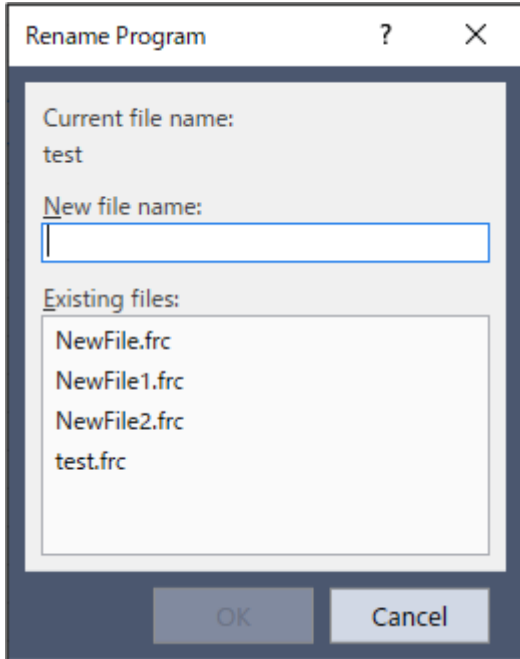

4.3.2.6 [Delete File] (File Menu)

Deletes a force file in the project folder.
The file to be deleted must not be listed in the project.

4.3.2.7 [Import File] (File Menu)

Imports a force file or a force guide sequence from another Epson RC+ 8.0 project.
Pay attention to the following point for the file name.

- When importing a force file:
The force file to be imported must have an ".frc" extension
- When importing a force guide sequence:
The force file to be imported must have a ".fg" extension

Importing a Force File

1. Select "Force (*.frc)" from the file type list.

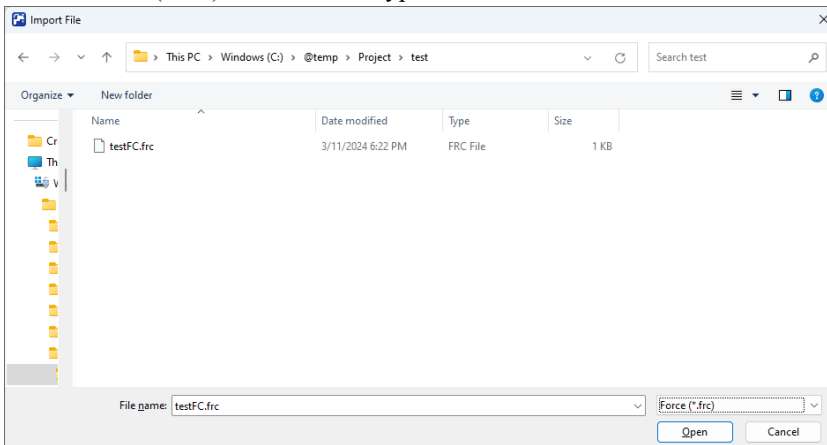

2. Select the drive, folder, and file name to be imported.

A file that is already listed in the current project cannot be imported. Select a file that is not listed in the current project.

3. Click the [Open] button.

If a file with the same name is already listed in the project folder, a message confirming whether to overwrite the existing file appears. The file is copied to the current project folder.

Importing a Force Guide Sequence

1. Select "Force Guide (*.fg)" from the file type list.

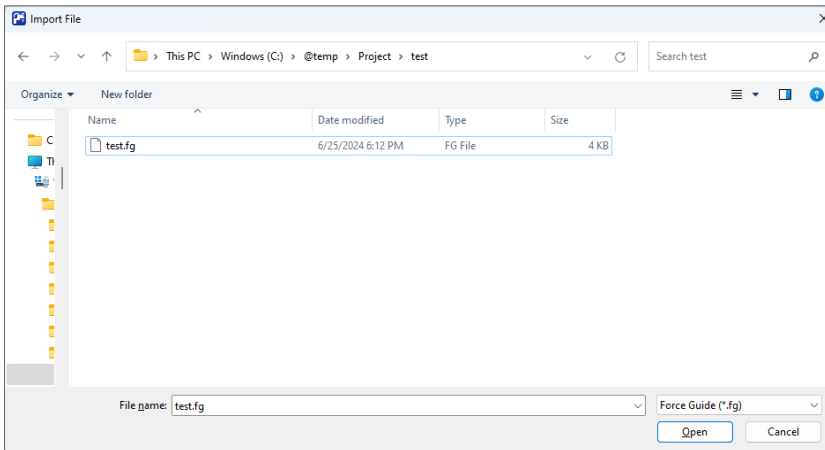

2. Select the following information, including a force guide sequence to be imported.

Drive, folder, and file name

3. Click the [Open] button. The list of the force guide sequences which are included in the selected file is displayed

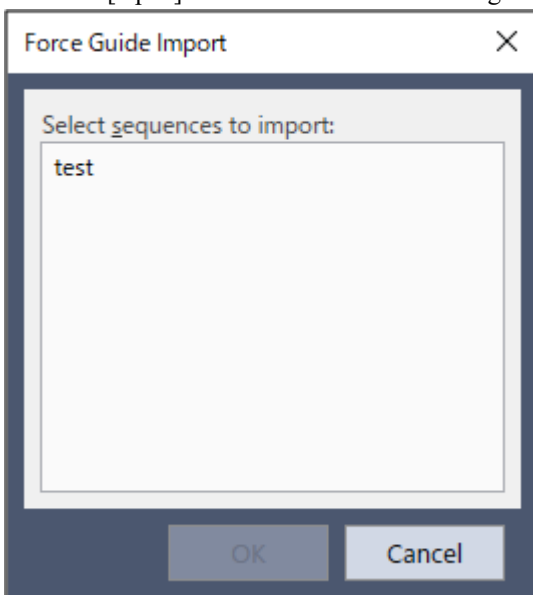

4. Select the force guide sequence to be imported.

5. Click the [OK] button.

If a file with the same name is already listed in the project folder, a message confirming whether to overwrite the existing file appears.

The force guide sequence is added to the current project.

4.3.2.8 [Exit] (File Menu)

Alt+F4

Exits Epson RC+ 8.0.

If the force file or the force guide file is not saved, a dialog box confirming whether to save the file appears. Click either the [Yes], [No], or [Cancel] button.

4.3.3 [Edit] menu

A force file can be edited from Epson RC+ 8.0 menu, [Edit].

4.3.3.1 [Cut] (Edit Menu)



: Ctrl+X

Cuts the selected data (string, force object, etc.).

4.3.3.2 [Copy] (Edit Menu)



: Ctrl+C

Copies the selected data (string, force object, etc.).

4.3.3.3 [Paste] (Edit Menu)



: Ctrl V

Pastes the cut or copied data (string, force object, etc.) to the cursor position.

4.3.3.4 [Select All] (Edit Menu)

Ctrl+A

Selects all force object items of the force file being edited. The selected items can be cut and copied.

4.3.4 [Project] Menu

Projects can be managed and built in the Epson RC+ 8.0 menu, [Project].

4.3.4.1 [Open Project] (Program Menu)

Opens an Epson RC+ 8.0 project.

Opening a project closes the open project. A message for confirming whether to save the changes appears.

When a project is opened with the [Read Only] checkbox selected, the force file cannot be edited.

4.3.4.2 [Edit Project] (Project Menu)

Set the force file to be used in the current project.
The "Force Control" is added to [Project Build].

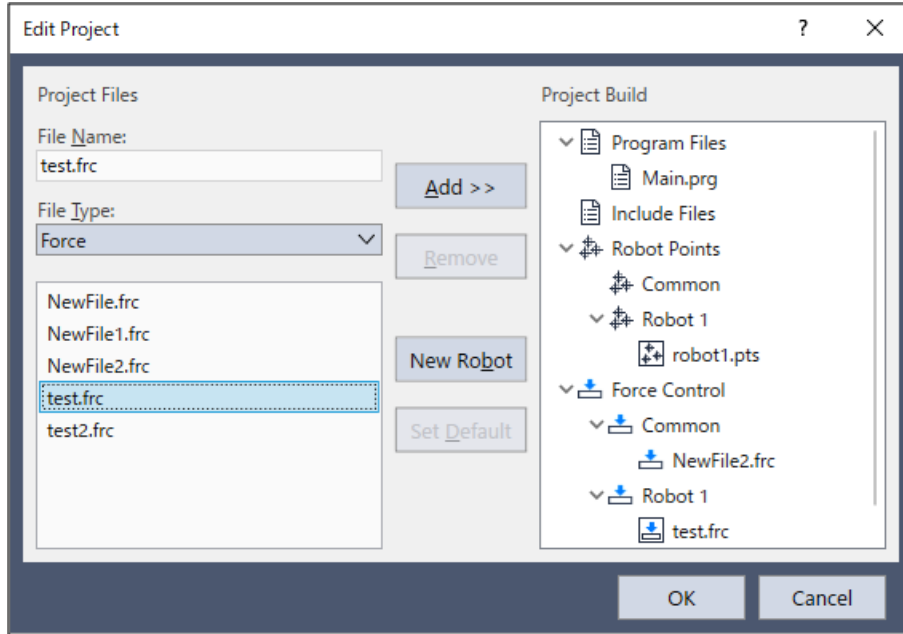

Adding a New Force File

1. In the File Name field, enter the name of the force file you wish to create. Be sure to add extension ".frc" to the file name. Please use alphanumeric characters and underscores [_]. Note: The initial character cannot be a numeric character. note that
2. From [Project Build]- [Force Control], select the robot folder to be added .
3. Click the [Add] button.
A message for confirming whether to create a new file appears. Click the [Yes] button.
A file is created and added to the robot folder selected in [Project Build]-[Force Control].

Adding an Existing Force File to the Project

1. Select "Force (*.frc)" in the [File Type] box.
2. From [Project Build]- [Force Control], select the robot folder to be added .
3. From the list, select the name of the force file to be added to the project.
4. Click the [Add] button. The file is added to the robot folder selected in [Project Build]- [Force Control].

Removing a Force File

1. Select the file to be removed from the [Project Build] tree.
2. Click the [Remove] button. The file name is removed from the [Project Build] tree. Since the file is not deleted from the project folder, it is displayed in the file list.

Setting Default for a Force File

1. For each robot folder in [Project Build]- [Force Control], select the force file which you want to set as the default.
2. Click the [Set Default] button. The force file is set to the default of the listed robot.

Key Point

- A common force file is a force file that can be used in all robots on the Controller. To use a common force file, you need to load it from the SPEL+ program using the FLoad command.
- A default force file is a force file that is automatically loaded to the robot when loading a project. One force file can be set to the default for each robot.

4.3.4.3 [Save Project] (Project Menu)

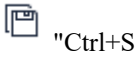

The following items are saved. If nothing needs to be saved, this menu is displayed in gray and cannot be selected.

- Program file
- Include file
- Point File
- Force File
- I/O label
- User error

4.3.4.4 [Project Properties] (Project Menu)

[Project]-[Project Properties]-[Operator Settings]-[Robot Manager]

Set up Robot Manager.

To enable the operator to edit the force data when displaying the operator window, place a checkmark in the [Force Page] checkbox.

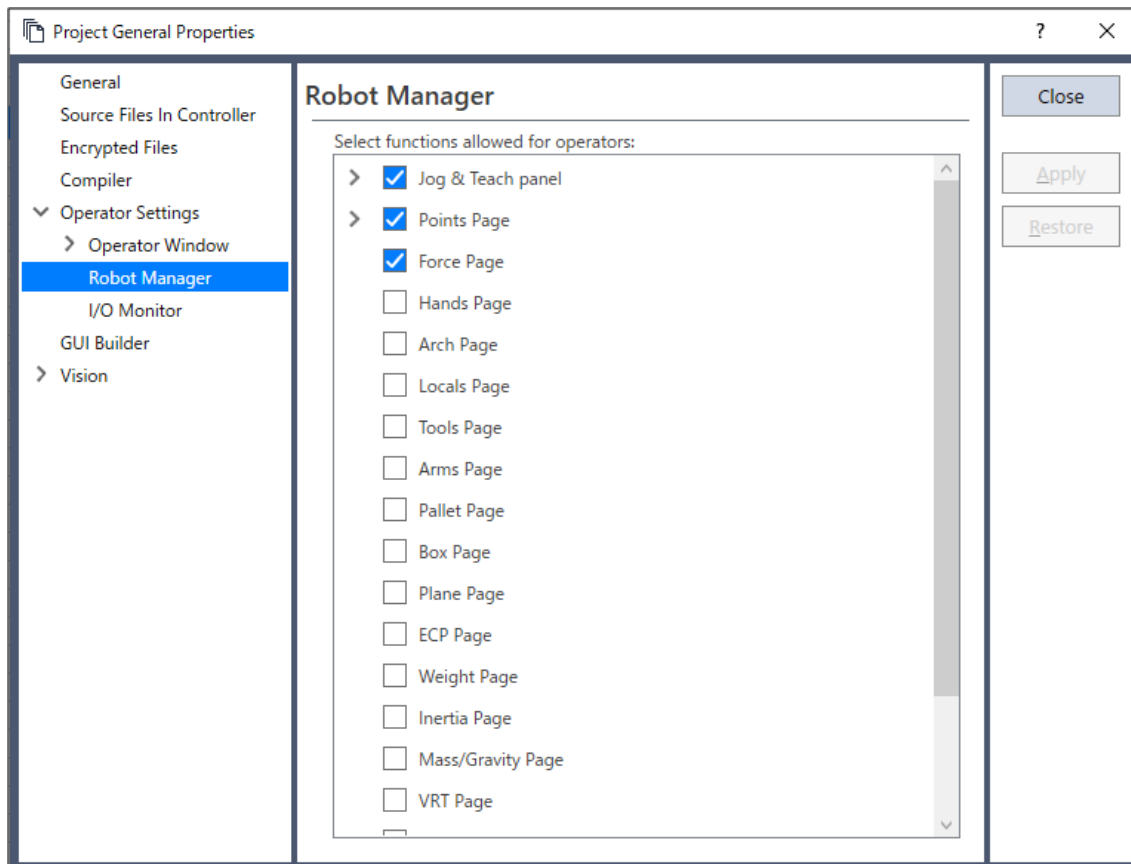

4.3.5 [Tools] menu

The Epson RC+ 8.0 has some GUI tools to support system development. You can access all tools from the Epson RC+ 8.0 menu-[Tools].

4.3.5.1 [Robot Manager] (Tools Menu)



F6

[Tools]-[Robot Manager]-[Force] Panel



Force: You can enter and delete the force control, force trigger, force coordinate system, force monitor, and force motion restriction objects.

When you select a force file, the Controller loads it into the memory. When using Robot Manager as an MDI sub-window, enter "Ctrl+S" to save the force data.

[Control] Panel

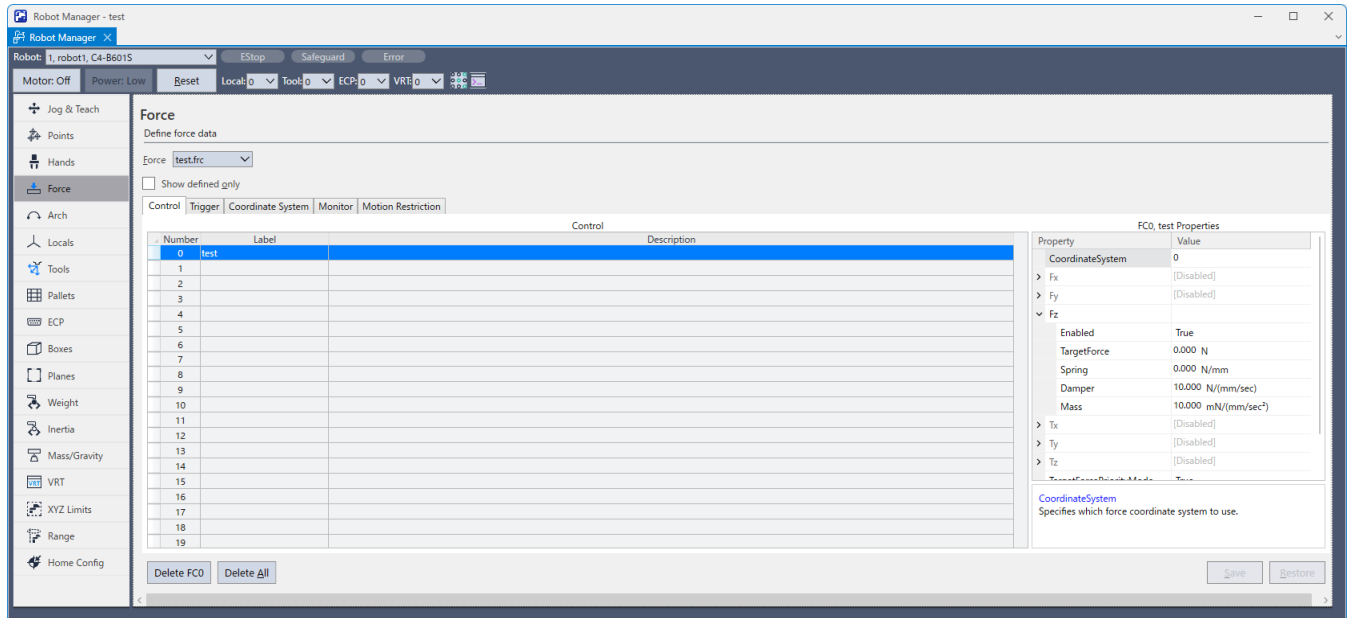
You can edit the force control object.



Item	Description
Force File	Selects the force file.
Show defined only	Display the defined data only.
Label	Sets the label (Label property).
Description	Sets the description (Description property).
Properties	Selects the properties to set the value.
[Drop-down list] 	Displays a list of values that can be selected. Select a value.
[Impedance Wizard] 	Displays Impedance Wizard, in which you can set each of the property values for force control objects (TargetForce, Spring, Damper, and Mass).

Item	Description
Delete Fxxx	Deletes the force object. A confirmation screen appears.
Delete All	Deletes all the force objects in the selected tab. A confirmation screen appears.
Save	Saves the values.
Restore	Restores the original values. A confirmation screen appears.

Impedance Wizard

1. Click the [Impedance Wizard] button  button in Properties. The [Impedance Wizard] window appears.

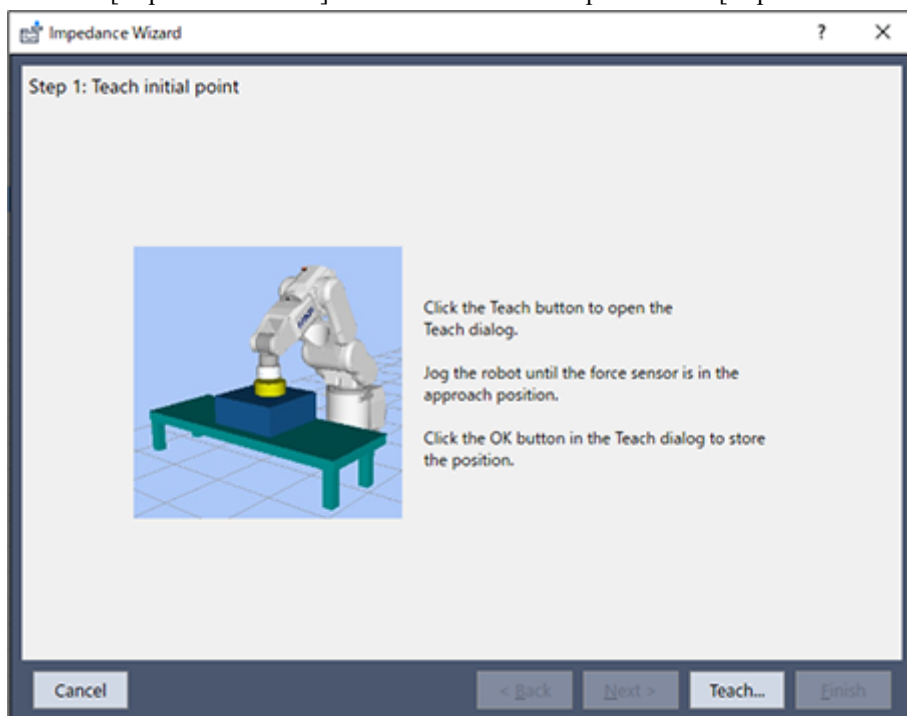

2. Click the [Teach...] button.

The [Teach Approach Point] dialog box appears. Move the robot to the point where the workpiece is about 1 mm above the object to be pressed.

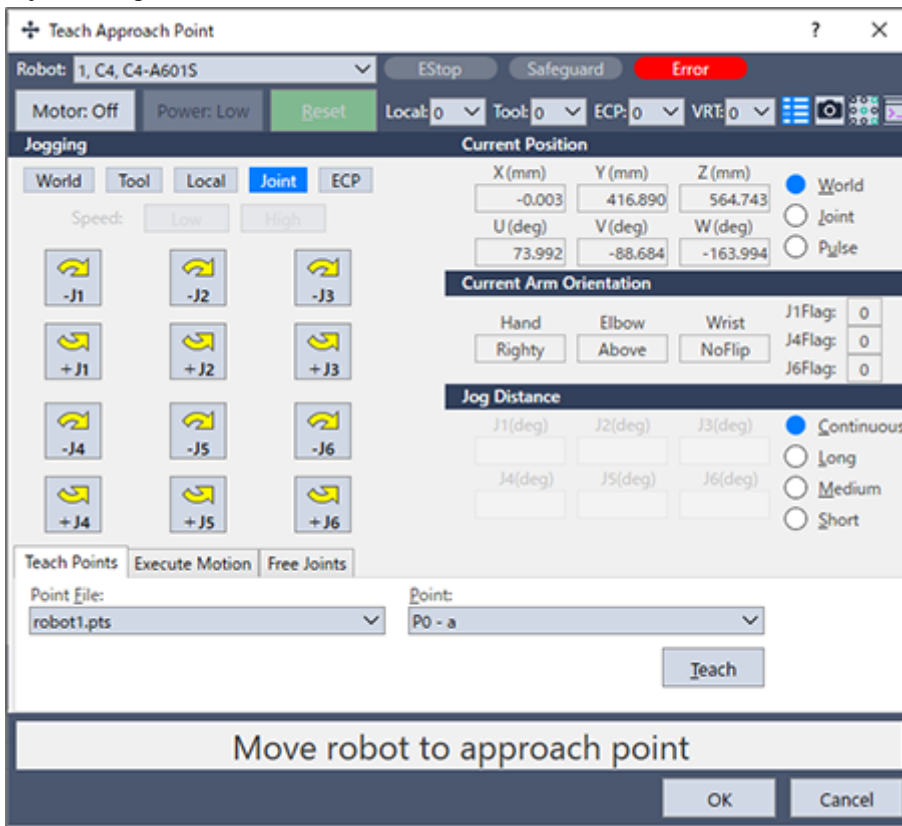

3. Click the [OK] button.

Save the current position and return to the [Impedance Wizard] window.

Set the values in [Force] and [Spring] of [Target Force].

Set the values in [Mass] and [Damper] of [Response / Stability] with a slider.

Set the slider to the "Stability" side first and adjust the values while checking the waveform of the actual force.

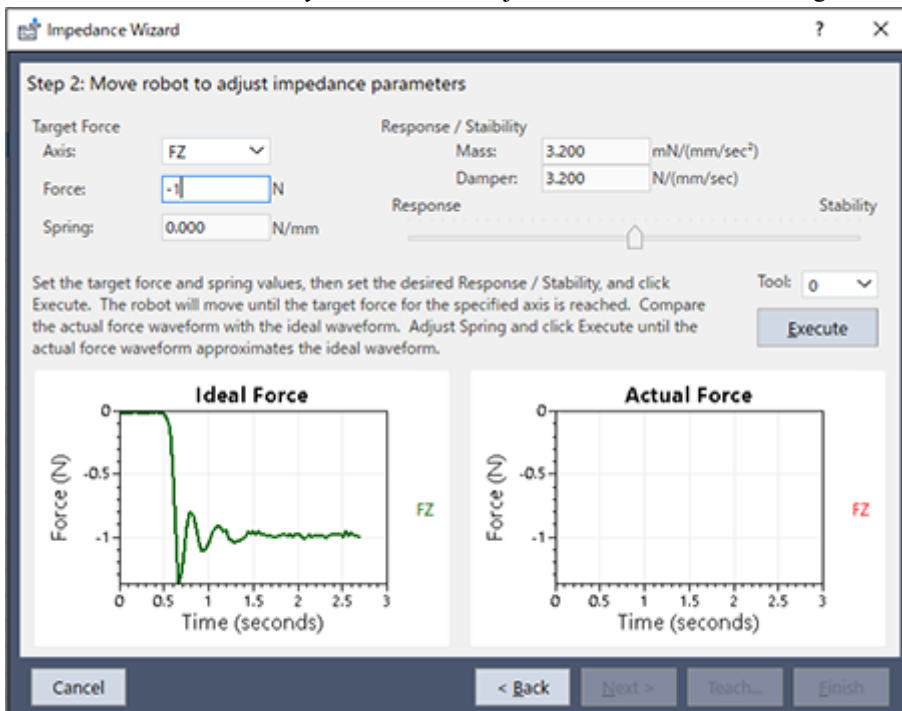

[Reference] [Force control function](#)

4. Click the [Execute] button. A confirmation dialog box is displayed.

Check that the workpiece in its initial position is within 1 mm of the object to be pressed, and then click [Yes].

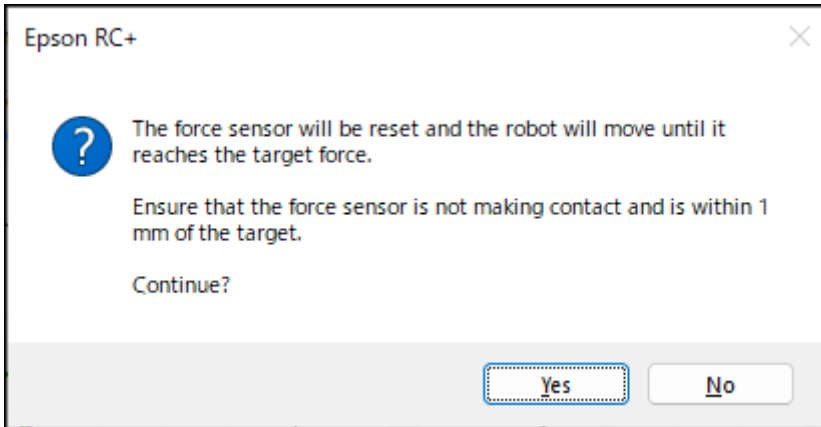

5. The robot moves until the set axis reaches the target force. To stop the robot during movement, click the [STOP] button.

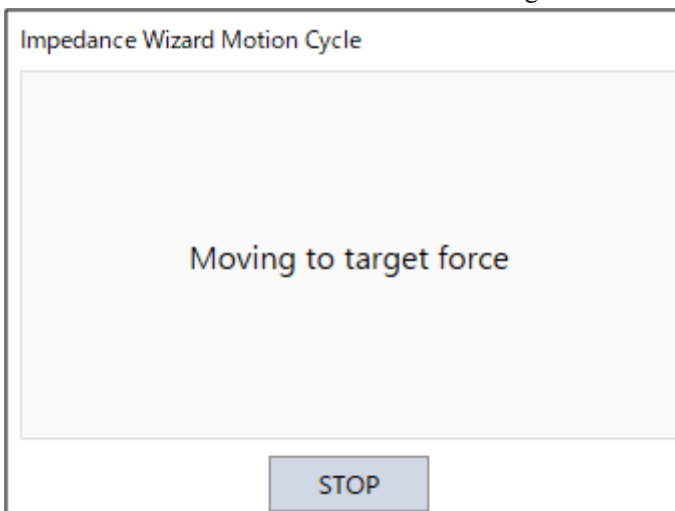

6. Adjust the [Spring] value and the slider until the measured data of force approximates the ideal waveform, and then click the [Execute] button.

Repeat the procedure until the actual force waveform approximates the ideal waveform.

If the waveform is vibrating or cannot settle at the target force, move the slider to "Stability" side.

If the waveform is too smooth, move the slider to "Response" side. When you move the slider too much, the force applied may change significantly. Move the slider gradually.

Note that if the [Spring] value is too large or the slider position is too stable, the robot may not be able to contact the workpiece. note that

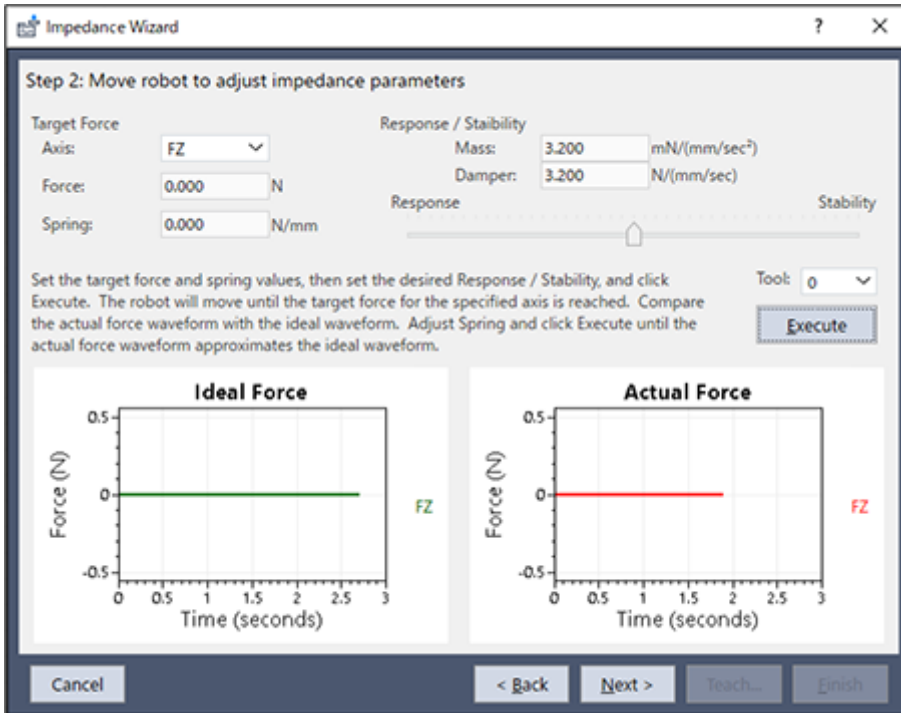

7. Click the [Next] button.

The impedance parameters before and after the adjustment for the set axis are displayed. To save a new value, click the [Finish] button. To cancel, click the [Cancel] button.

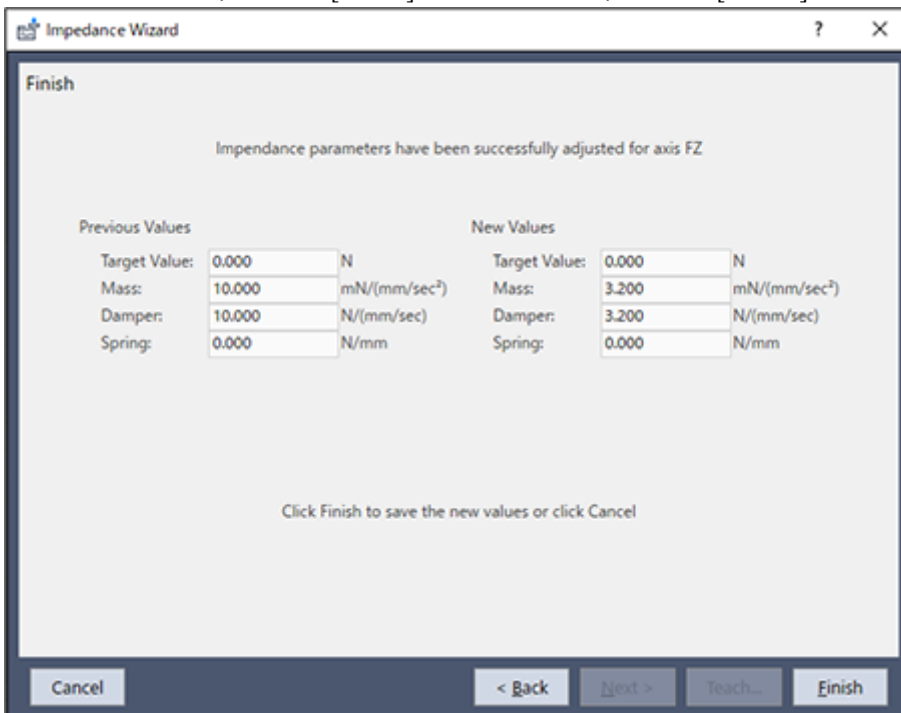

[Trigger] Panel

You can edit the force trigger object.

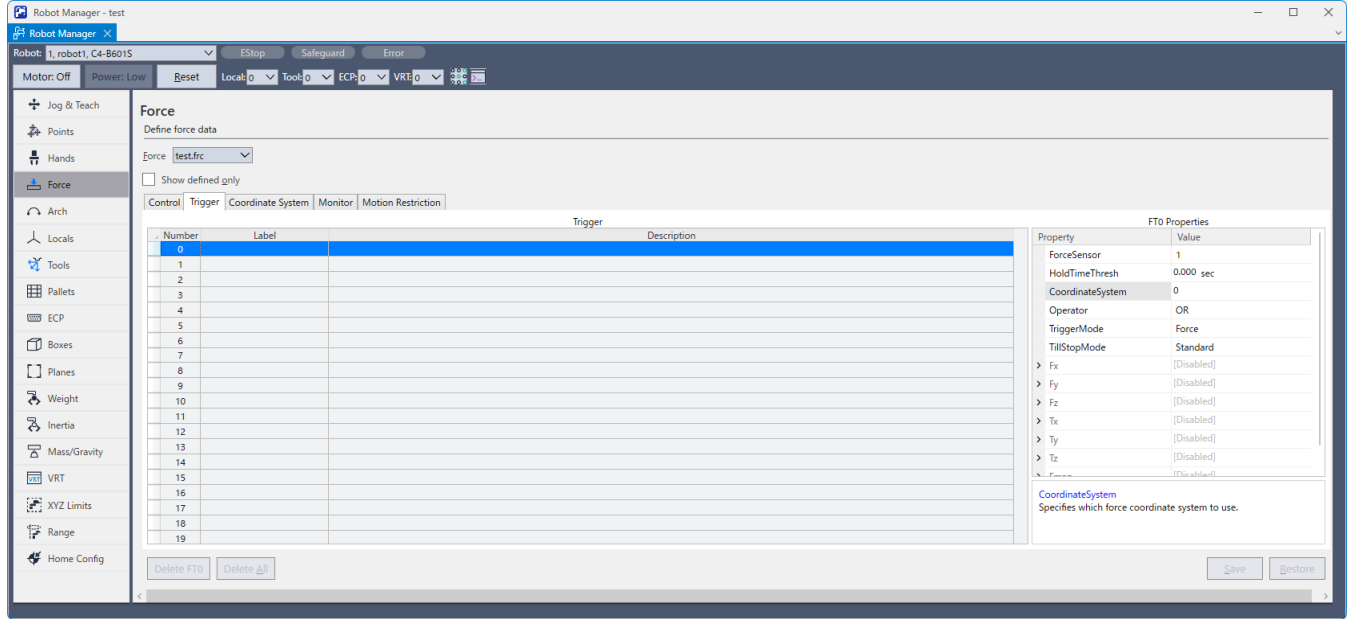

[Coordinate System] Panel

You can edit the force coordinate system object.

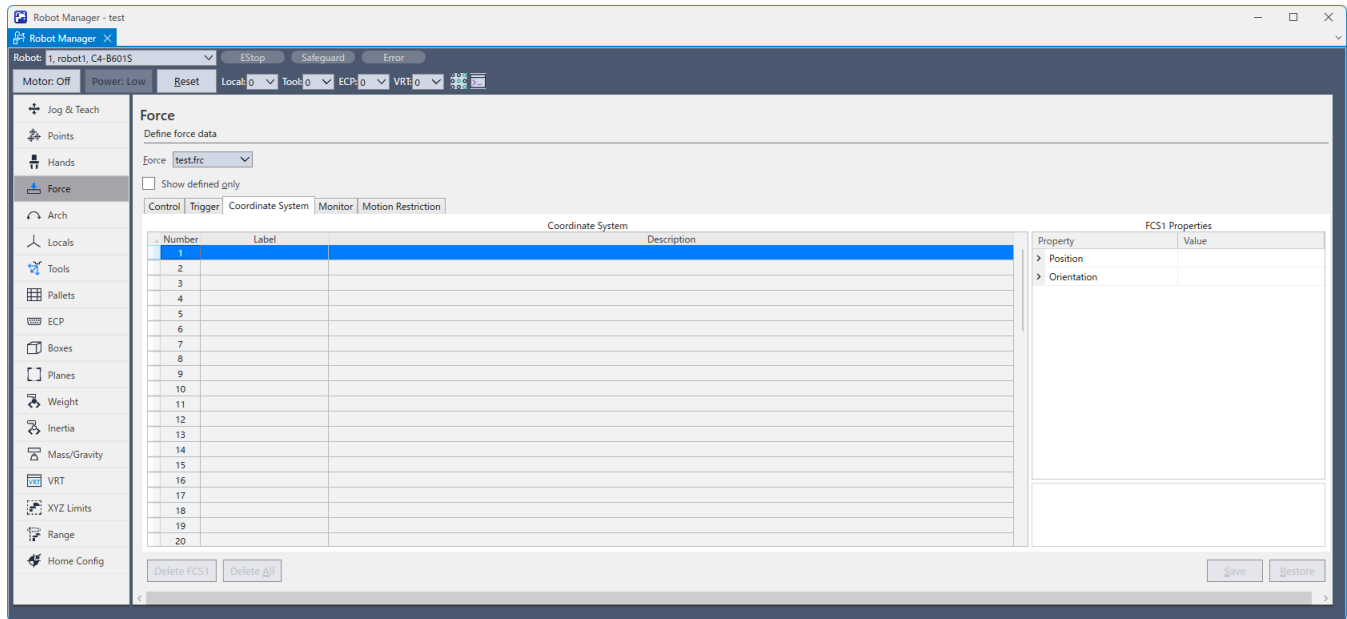

[Monitor] Panel

You can edit the force monitor object.

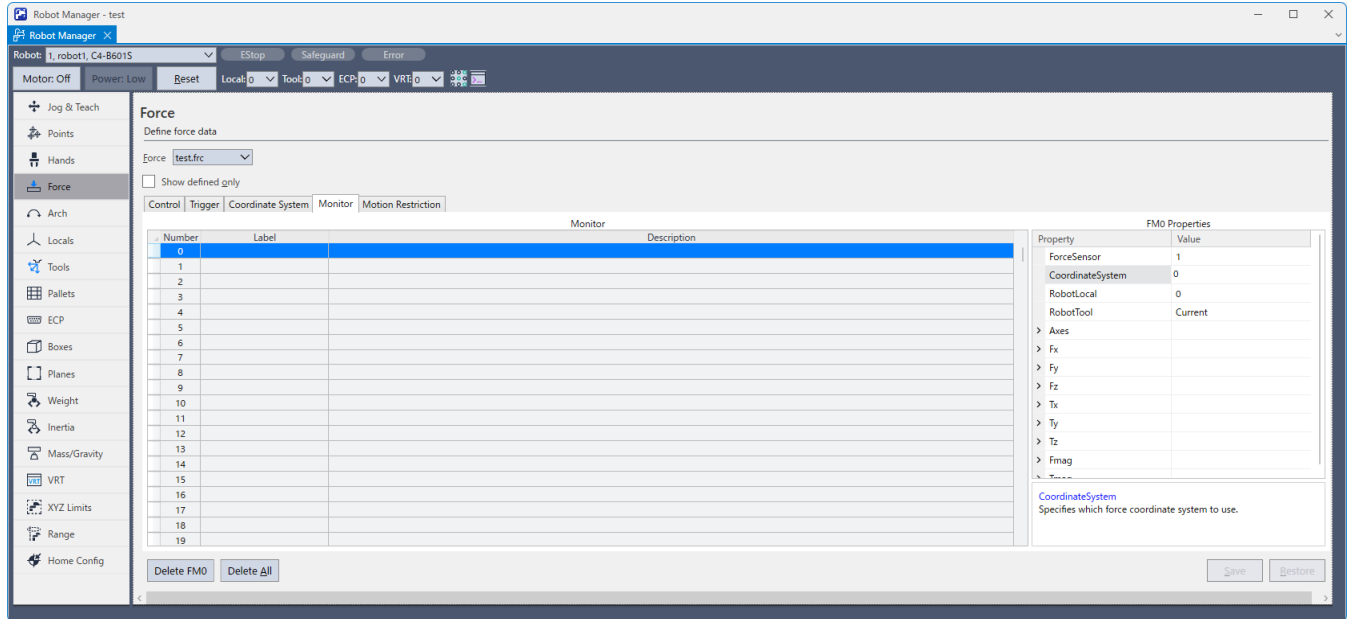

[Motion Restriction] Panel

You can edit the force motion restriction object.

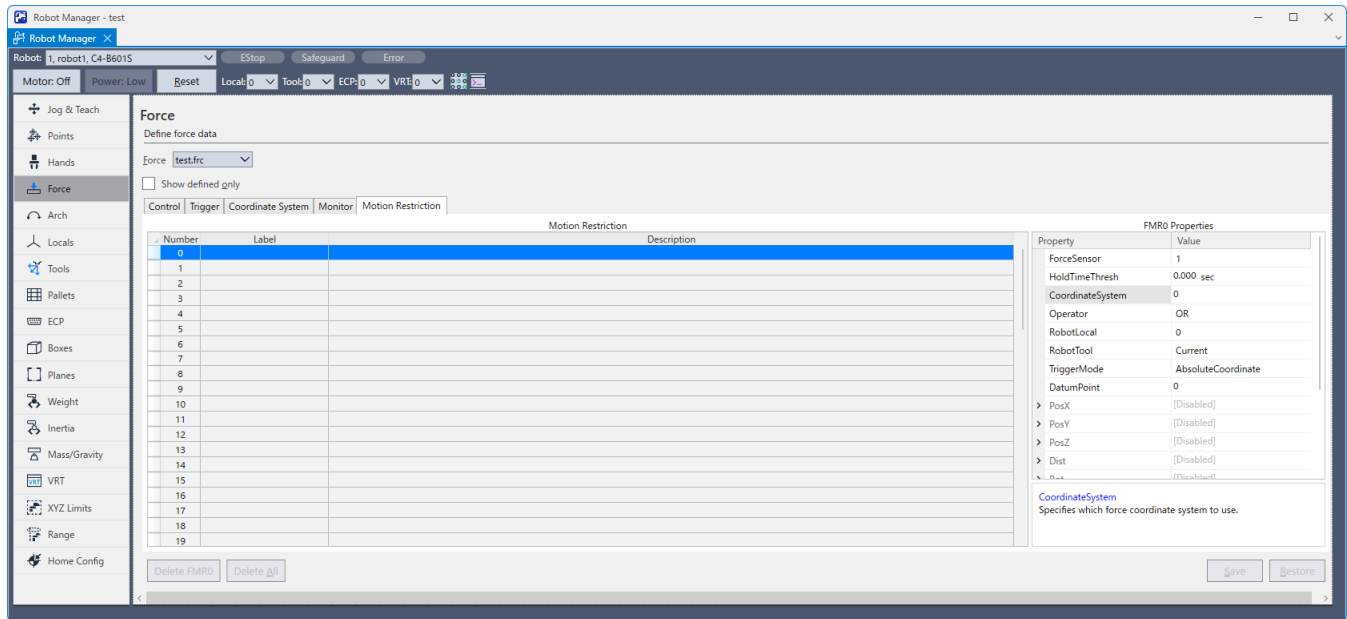

4.3.5.1.1 [Tools]- [Robot Manager]-[Mass/Gravity] Panel

You can set the values of the mass properties.

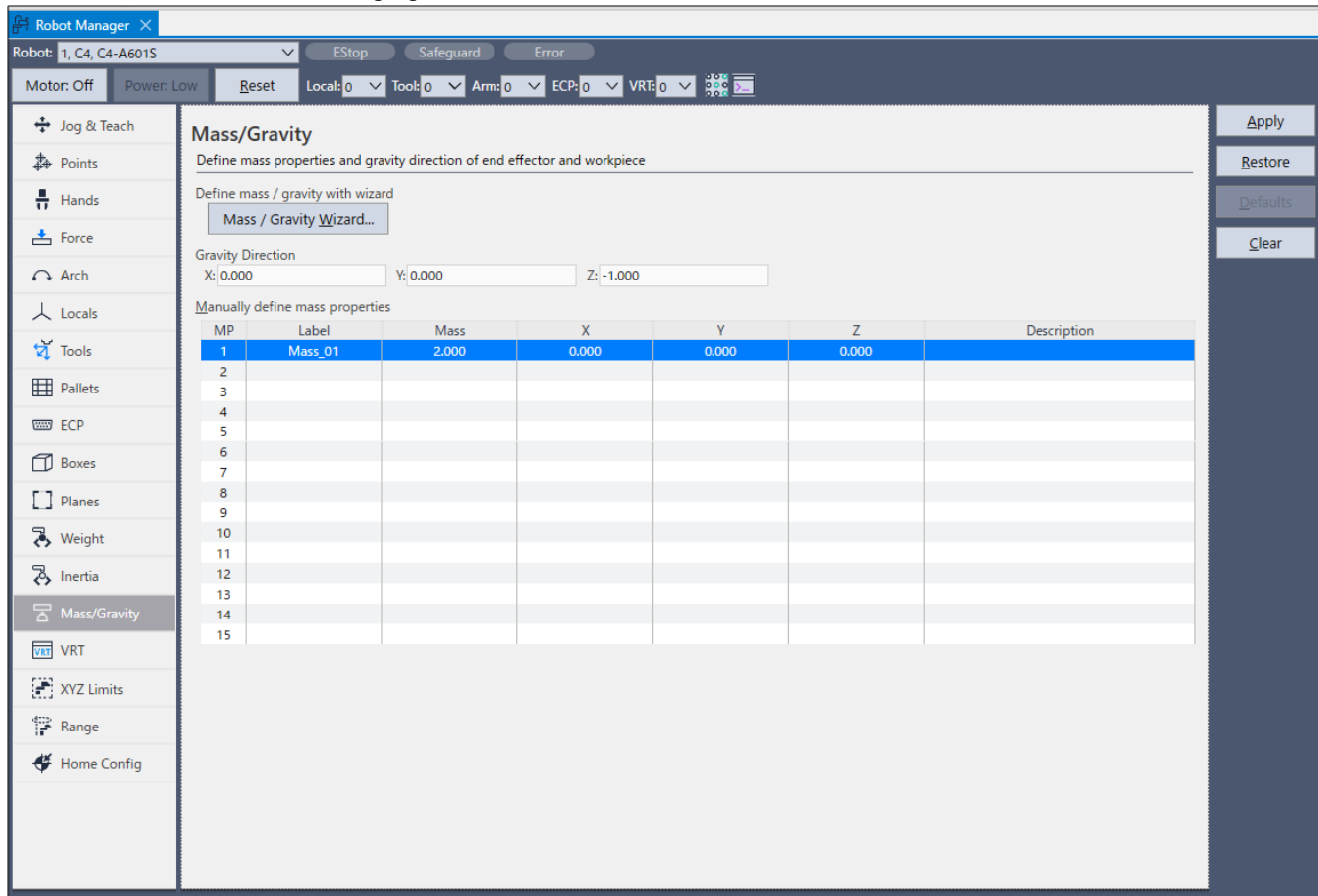

Item	Description
Mass / Gravity Wizard	Displays Mass / Gravity Wizard, in which you can set the property values of the mass property object.
Gravity Direction	Set the gravity direction of the robot (robot object GravityDirection property).
Manually define mass properties	Set the following items of the mass property object with MP (number). Label (Label property). Mass Property X / Y / Z (GravityCenter property) Description (Description Property)
Defaults	Sets the default value in the gravity direction.
Clear	Deletes the selected mass property object.

Mass/Gravity Wizard

1. Click the [Mass / Gravity Wizard] button.

[Step 1: Select Mass Properties Number] appears in the [Mass / Gravity Wizard] window.

You can define the mass properties.

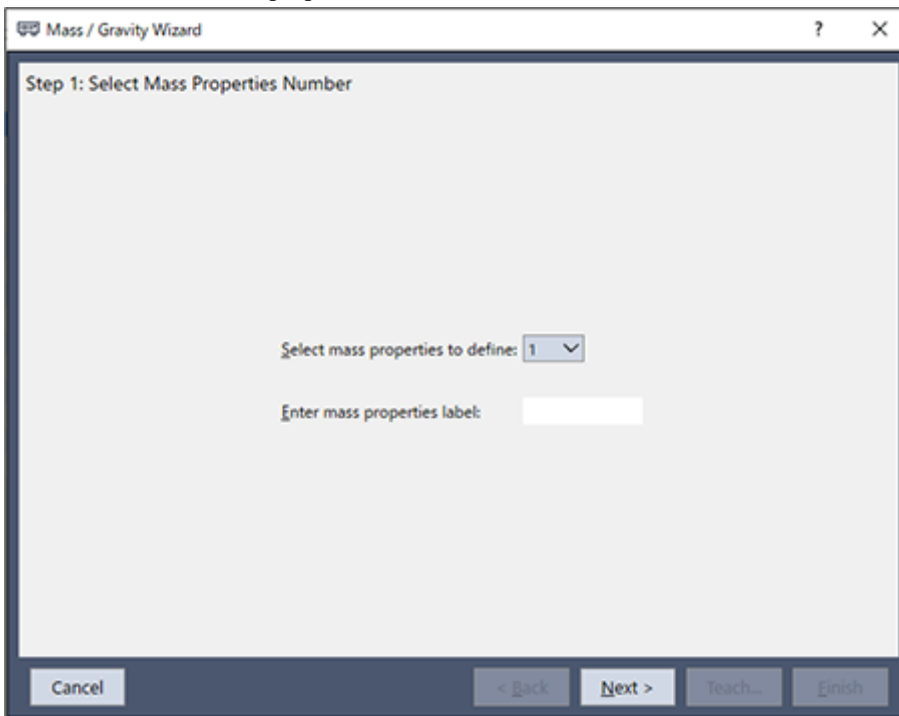

2. Select the number in [Select mass properties to define]. The mass properties label for the selected number is displayed in [Enter mass properties label]. The label name can be changed.

3. Click the [Next] button. [Step 2: Teach initial point] appears in the [Mass / Gravity Wizard] window.

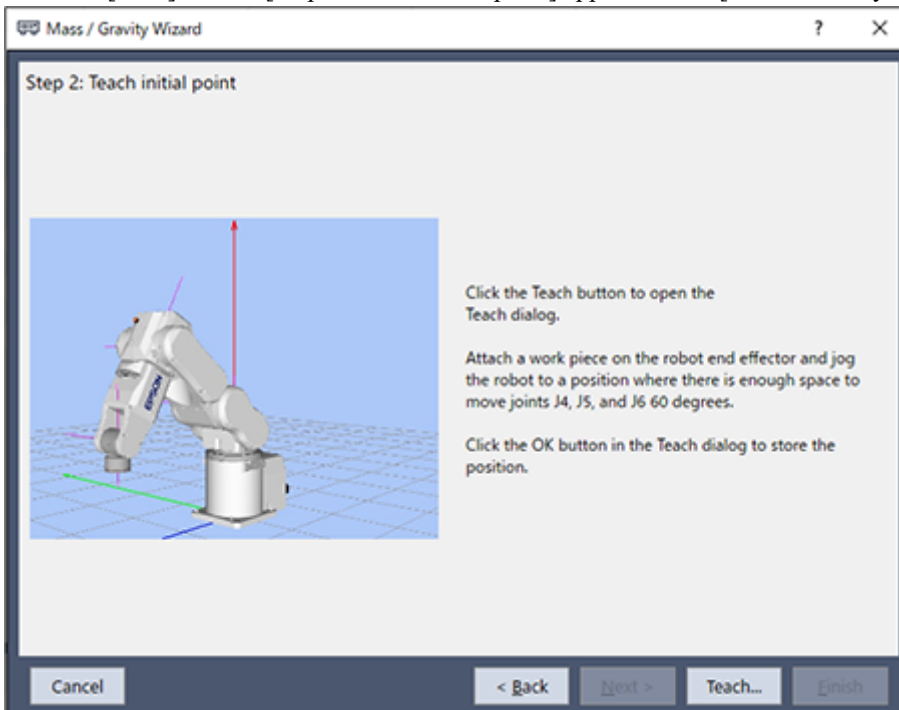

4. Click the [Teach] button.

The [Jog & Teach] window appears. Mount the workpiece to the end effector (hand tip) of the robot and move the robot to the position where J4, J5, and J6 can move at 60 degrees.

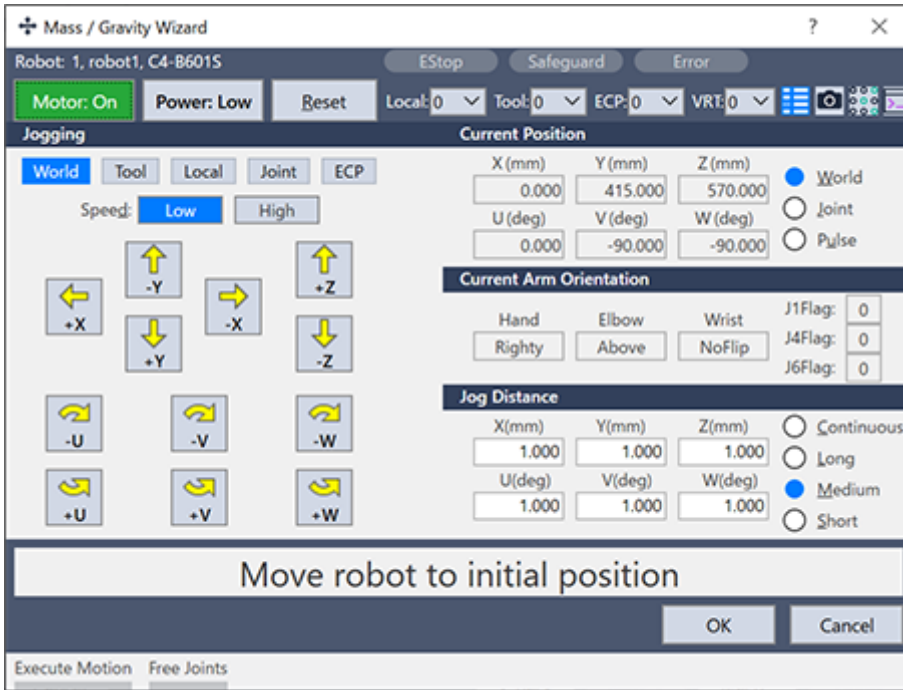

5. Click the [OK] button.

The position information is saved.

[Step 3: Move robot to collect data] appears in the [Mass / Gravity Wizard] window. In this step, the robot moves in 8 steps.

You can select the motion direction of joints [J4], [J5], and [J6] from "+" and "-" in [Joint Motion Directions].

You can select the speed for the posture check using step buttons from "Low" and "High" in [Motion speed].

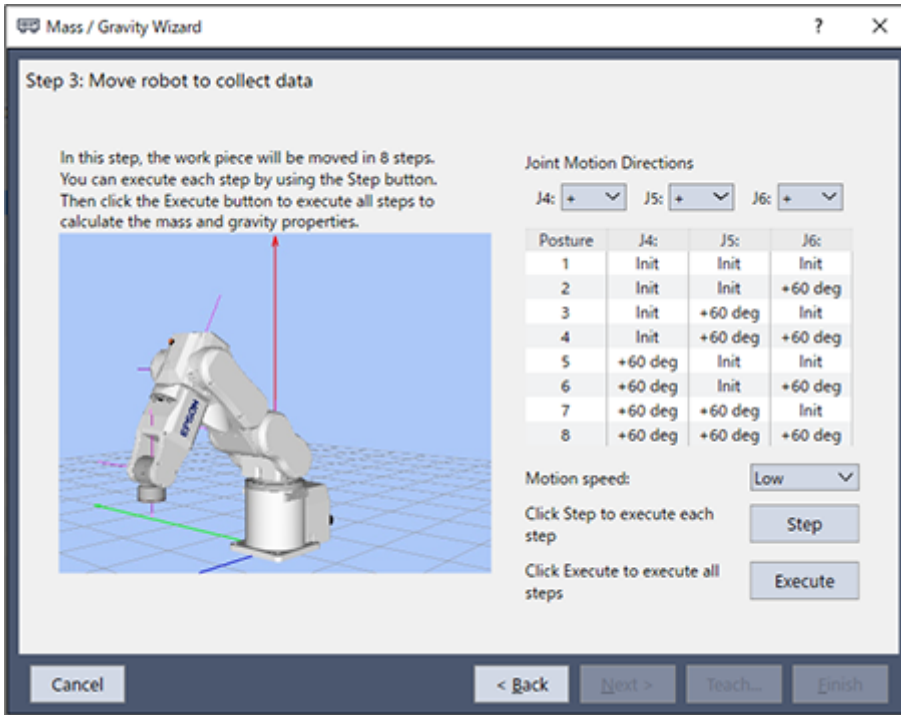

Click the [Step] button in (5) to view the posture of each step. The following message is displayed.

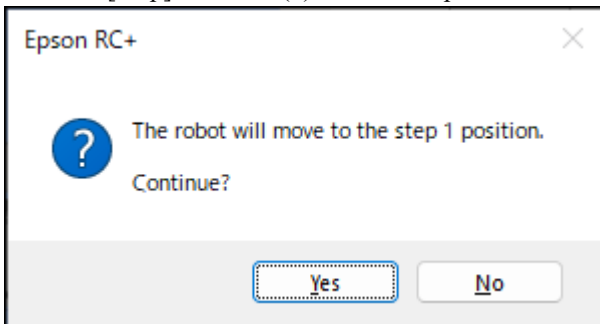

Click the [Yes] button to display the [Execute Command] dialog box and start moving the robot.

Click the [Step] button to check if the robot interferes with the end effector and peripherals for the posture of each step.

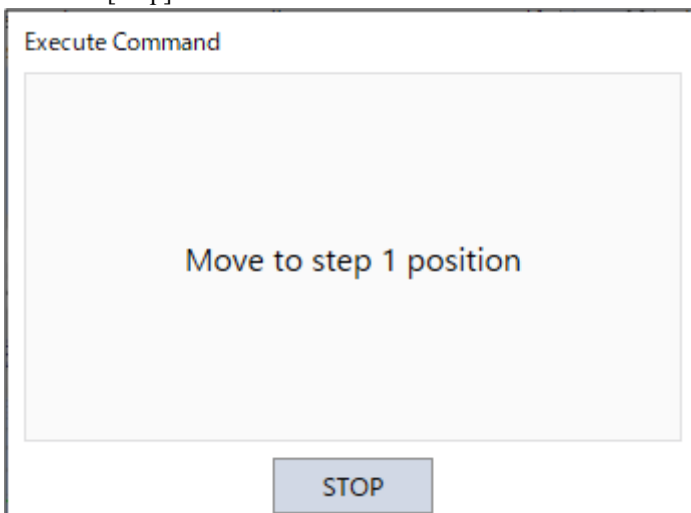

To stop the robot during movement, click the [STOP] button.

Click the [Execute] button in (5) to execute all the steps to measure the mass properties.

The following message is displayed.

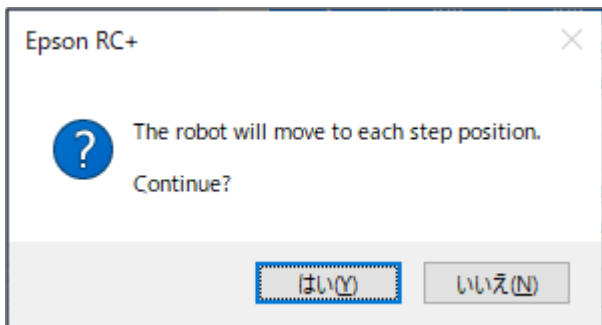

Click the [Yes] button to display the [Mass / Gravity Calibration] dialog box and start moving the robot.

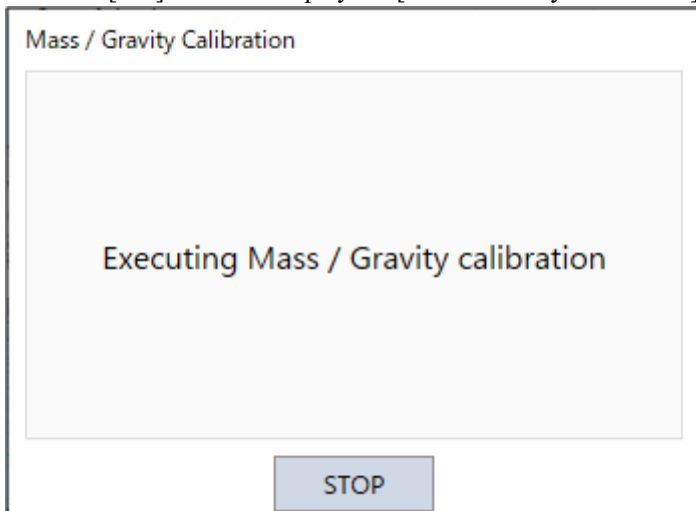

To stop the robot during movement, click the [STOP] button.

- When the movement is completed, the [Finish] button appears in the [Mass / Gravity Wizard] window. The mass properties and gravity direction values are displayed in [Previous Values] and [New Values].

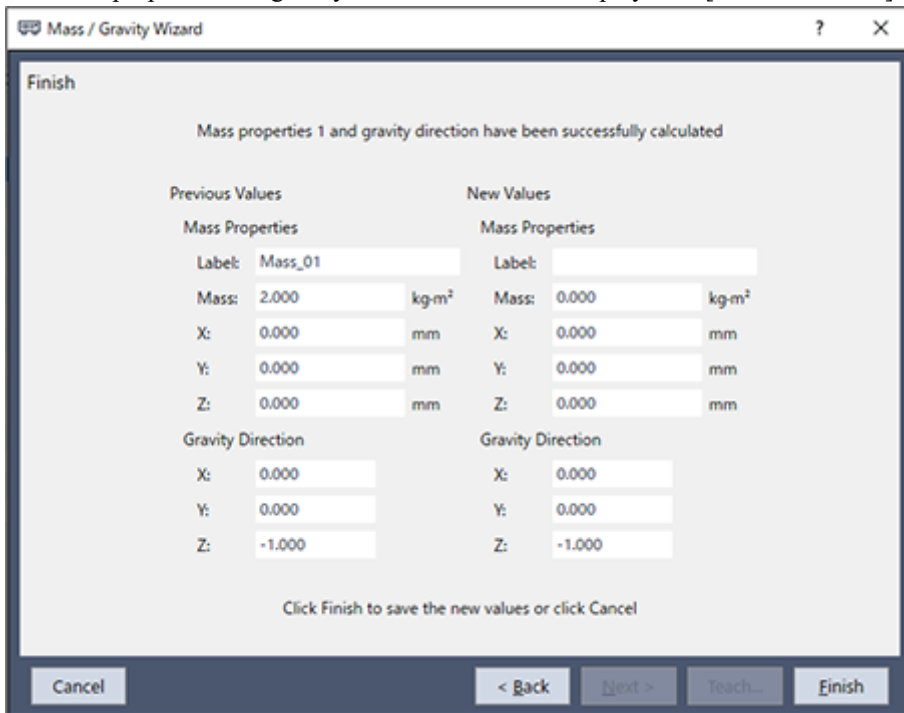

- Click either of the following buttons.
 [Finish] button : Saves the new values.
 [Cancel] button : Cancel the new values.

4.3.5.2 [Force Monitor] (Tools Menu)

It is possible to display the current force values and analyze or compare the past values.

From the Epson RC+ 8.0 - menu, select [Tools]-[Force Monitor], or click the [Force Monitor]  button on the toolbar.

The [Force Monitor] window appears.

The window displays different dialog box depending on selection of [Mode] (Live, Runtime, Log).

4.3.5.2.1 The [Mode]-[Live] button

4.3.5.2.1.1 Details of the displayed dialog box

Select the [Mode]-[Live] button to display the following dialog box

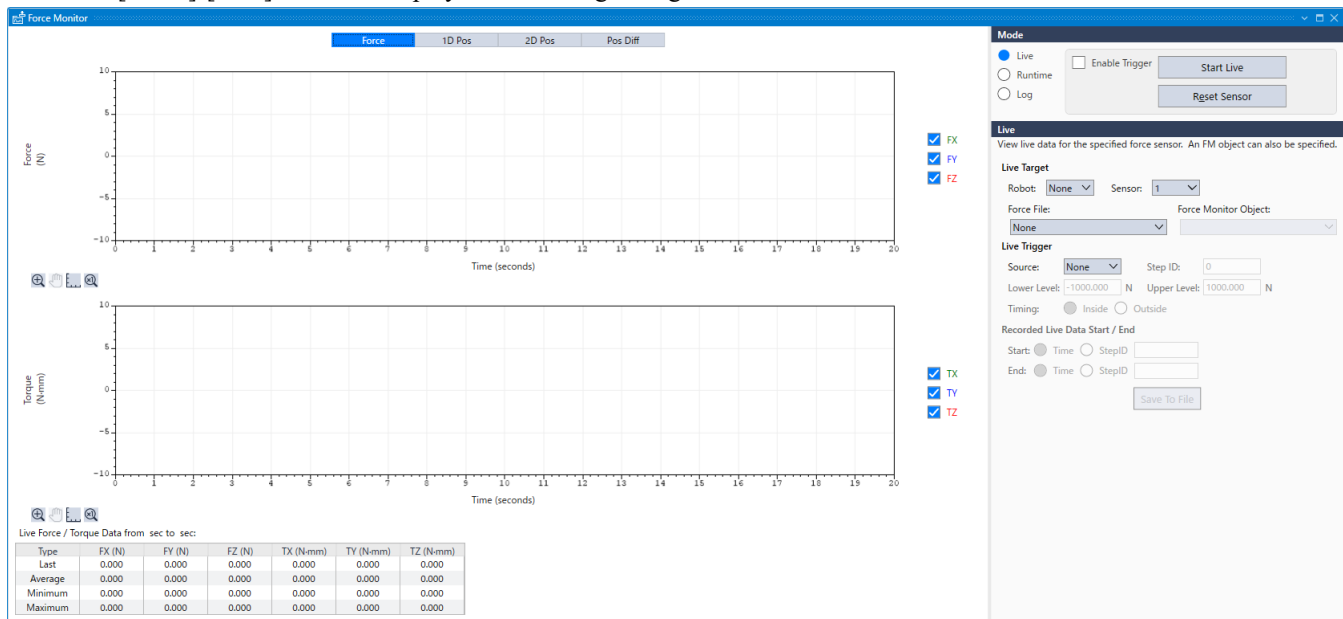

Item	Description
Graph area	By starting "Live", the force information detected by Force Sensor and the position information of the robot are displayed on a graph in real-time. There are [Force], [1D Pos], [2D Pos], and [Pos Diff] tabs in graph area. You can switch them depending on the use. For details of each tab, refer to the following section. Graph
[Enable Trigger] checkbox	When placing a checkmark in the checkbox and starting "Live", start to display the data in the graph by satisfying the conditions set by trigger.
[Start Live] button	Click the button to start "Live". After clicking the [Start Live] button, "Live" continues for 600 seconds at the maximum. Displayed button is changed to [Stop Live].
[Stop Live] button	Click the button to stop "Live". Displayed button is changed to [Start Live].
[Reset Sensor] button	Reset the Force Sensor. Values of force and torque will be "0".

Item	Description
Robot	Set a robot number that will be a target of "Live". When selecting a robot, Force Sensor that will be a target of "Live" is automatically selected.
Sensor	Set a number of Force Sensor that will be a target of "Live". Specifying the Force Sensor number displays the force information in Force Sensor r coordinate system.
Force File	Set the file in which the force monitor object is stored. When "None" is selected, the force information of Force Sensor coordinate system is displayed.
Force Monitor Object	Select from a list of objects (number: label) that are defined by files set in force file. When specifying the force monitor object, force information of the force coordinate system is displayed.
Live Trigger	Set a trigger of start conditions when placing a checkmark in the [Enable Trigger] check box and starting "Live".
	Source : Select the object of the trigger. When you do not set a trigger, select "None".
	Step ID : Set StepID as a start condition.
	Lower Level : Set the lower threshold value of the trigger.
	Upper Level : Set the upper threshold value of the trigger.
	Timing : Set the timing of the trigger. [Inside] : the value set above. When the value falls inside the range [Outside] : the value set above. When the value falls outside the range
Recorded Live DataStart / End	Set a display range of Live data. Time : Set a start time or an end time. StepID: Set the StepID to start or end.
Save To File	Save the "Live" result data which is currently displayed in the graph to a file. When the [Save To File] button is clicked, [Save Data To File] dialog box of the log data is displayed. To save the data to a file, set the destination to save and a file name and click the [Save] button.

4.3.5.2.1.2 "Live" Flow

Start "Live"

Before starting "Live," make sure to check that the contents of the Live setting are correct.
(robot number, sensor number, force file, and force monitor object)

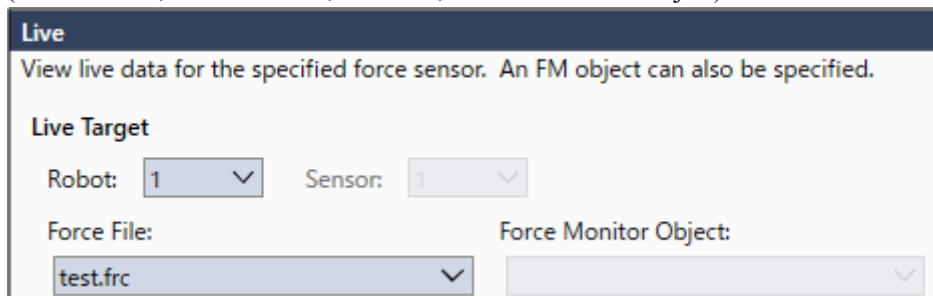

Click the [Start Live] button and start "Live".

When "Live" is started, the data will be displayed in the graph and updated in real-time.

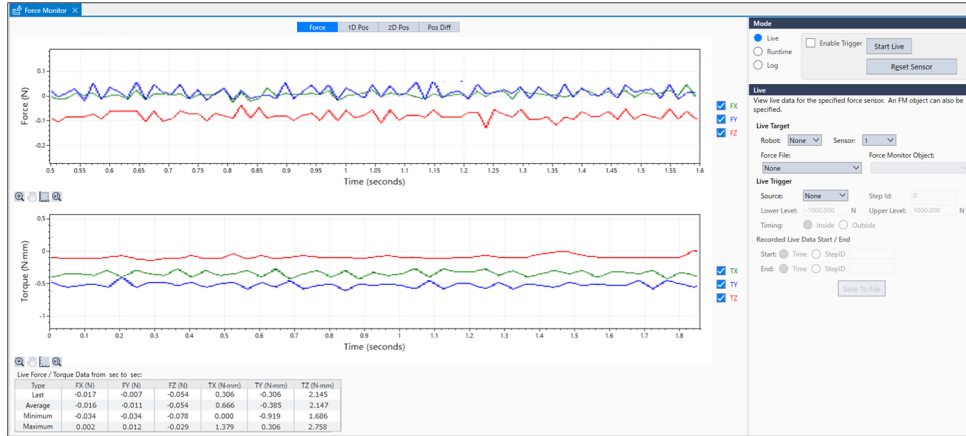

Stop "Live"

To stop "Live", click the [Stop Live] button.

It stops automatically when 600 seconds has passed after the [Start Live] button has been clicked.

When the [Stop Live] button is clicked, the data update will stop.

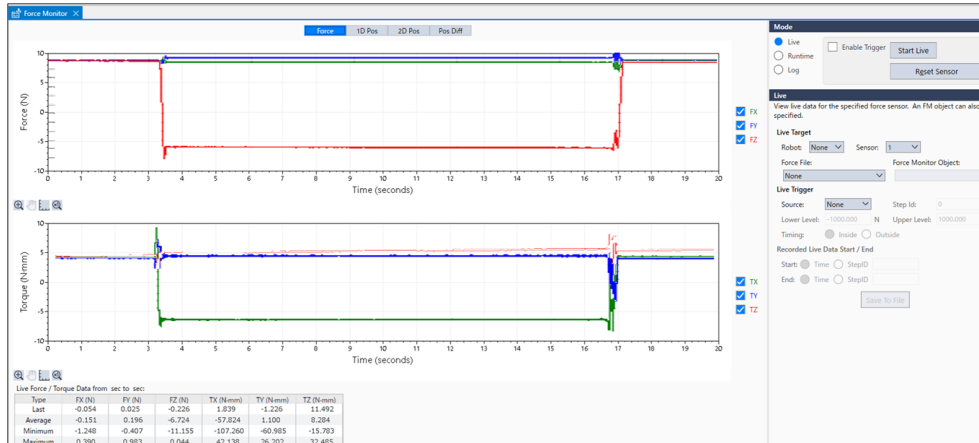

When 600 seconds has passed after the [Start Live] button has been clicked, the data update will automatically stop.

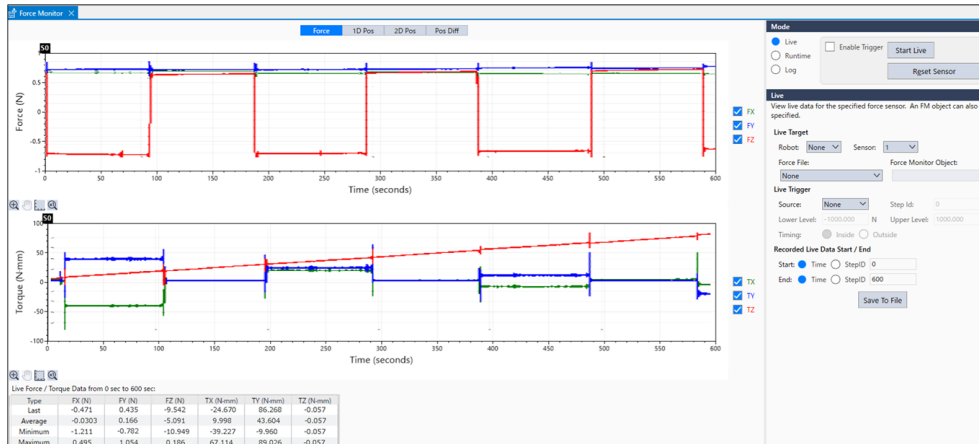

When 600 seconds has passed, the following message is displayed.
To restart "Live", click the [OK] button and click the [Start Live] button again.

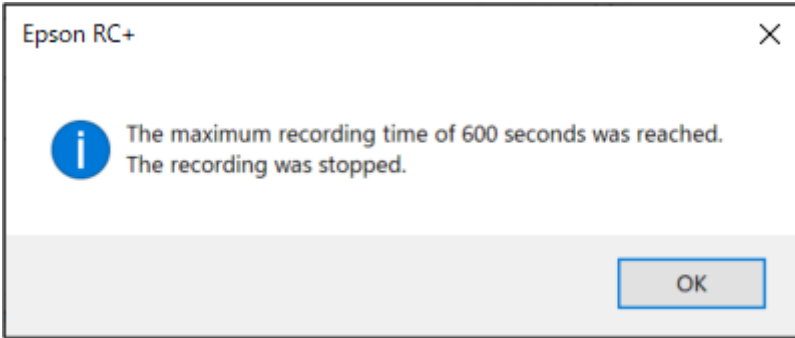

4.3.5.2.1.3 "Live" flow when enabling the trigger function

Start "Live"

Place a checkmark in the [Enable Trigger] checkbox.

Before starting "Live", make sure to check the contents of Live setting or Live trigger are correct.

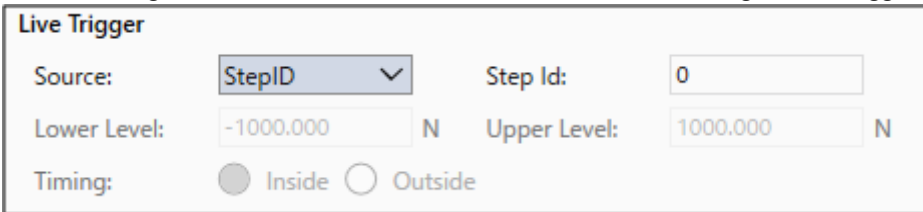

Make sure that the target trigger or trigger conditions are correct.

Click the [Start Live] button and start "Live".

Before the trigger conditions are satisfied: The data is not displayed in the graph. When the trigger conditions are satisfied, data will be displayed in the graph.

Before the trigger conditions are satisfied: The data is not displayed in the graph.

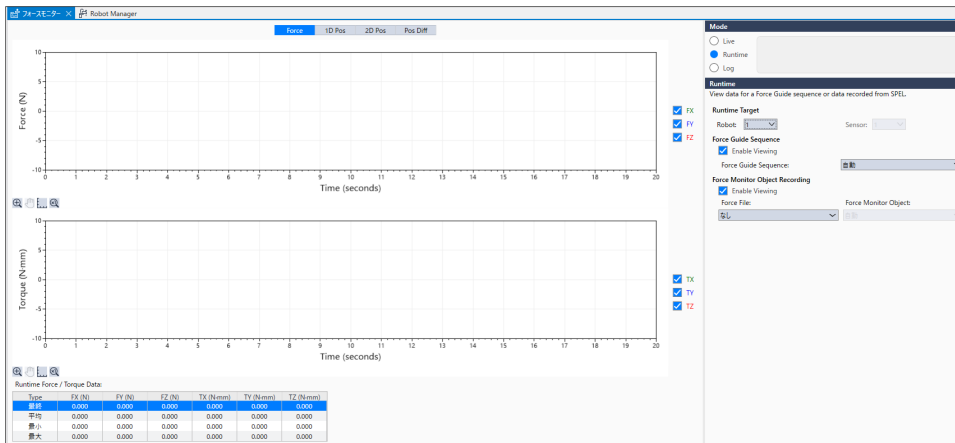

After the trigger conditions are satisfied: The data is displayed in the graph and keep updating in real-time.

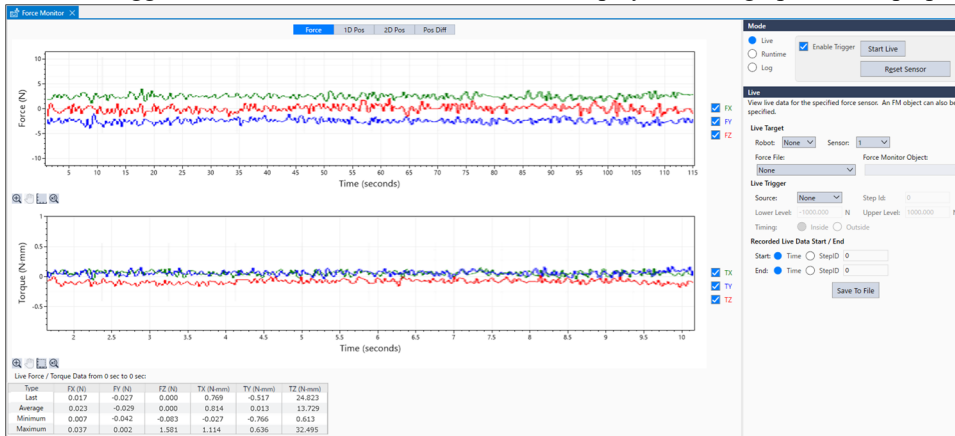

Stop "Live"

To stop "Live", click the [Stop Live] button. It stops automatically when 600 seconds has passed after the [Start Live] button has been clicked.

(It is not 600 seconds after the data is started to be displayed.)

When the [Stop Live] button is clicked, the data update will stop.

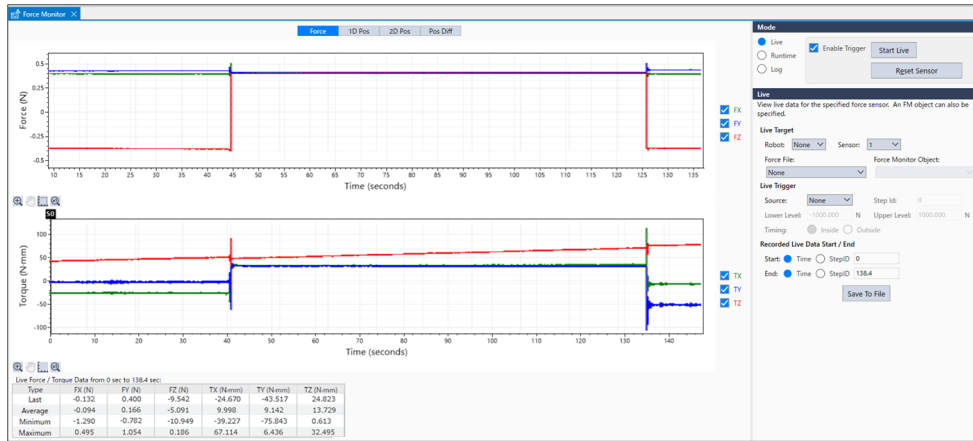

When 600 seconds has passed after the [Start Live] button has been clicked, the data update will automatically stop.

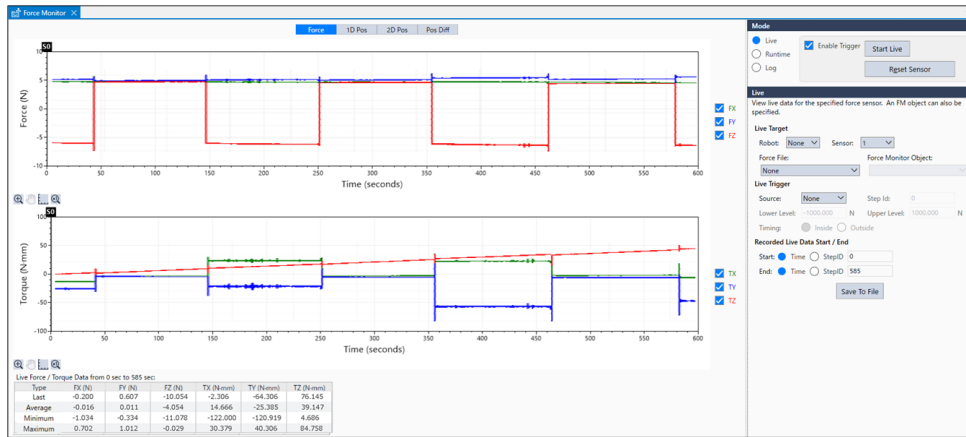

4.3.5.2.2 [Mode]-[Runtime] button

4.3.5.2.2.1 Details of the displayed dialog box

Select [Mode]-the [Runtime] button, the following dialog box is displayed.

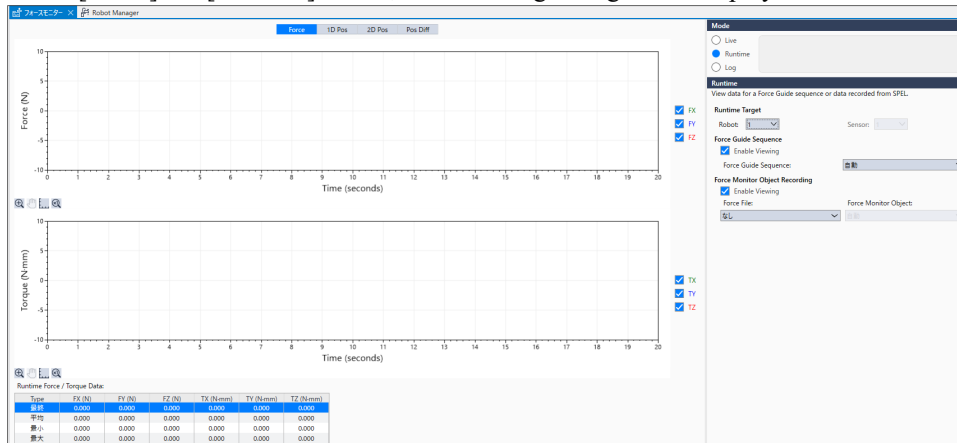

Item	Description
Graph area	By execution of the force guide sequence or record execution by the force monitor object, the force information detected by Force Sensor and the position information of the robot are displayed on a graph in real-time. There are [Force], [1D Pos], [2D Pos], and [Pos Diff] tabs in graph area. You can switch them depending on the use. For details of each tab, refer to the following section. Graph
Robot	Select a robot number that will be a target of "Runtime". When selecting a robot, Force Sensor that will be a target of "Runtime" is automatically selected.
Sensor	Set a number of Force Sensor that will be a target of "Runtime".
Force Guide Sequence	Set a force guide sequence to be displayed on a graph when executing a program.
	Graph display : Select enable/disable the graph display. Force guide sequence: Select a force guide sequence to be displayed on a graph. If selecting "Any", all force guide sequences will be displayed.
Force Monitor Object Recording	Set conditions of the graph display for the recording by RecordStart property.
	Graph display : Select enable/disable the graph display.
	Force file: Set a force file that the force monitor object to be displayed on a graph is saved. When "None" is selected, all force monitor objects will be displayed on a graph.
	Force monitor object : Set a force monitor object to be displayed on a graph. When the force monitor object is set: Even the RecordStart property is executed by the other force guide object, the data is saved in a file, but not displayed in the graph.

4.3.5.2.2 Graph display when executing the force guide sequence

Before executing the force guide sequence, make sure to check the Runtime setting is correct.

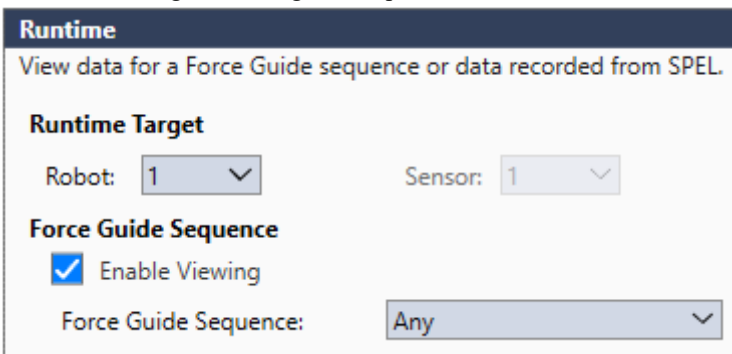

Check the following items: Target robot number or sensor number is correct. Graph display of force guide sequence setting or target force guide sequence is correct.

When the setting is correct, execute the force guide sequence on Force Guide window or by the FGRun Statement.

- When you have executed a force guide sequence which does not satisfy the condition:
The graph is not displayed.
- When you have executed a force guide object which satisfies the condition:
The graph is displayed.

When the conditions are satisfied, the data is displayed on a graph.

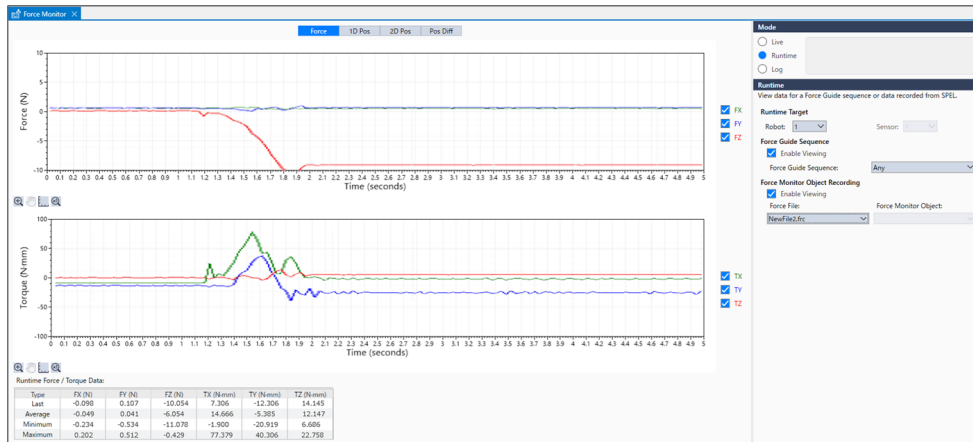

4.3.5.2.2.3 Graph display when the record is executed by the force monitor object

Before executing the record by the force monitor object, make sure to check the Runtime setting is correct.

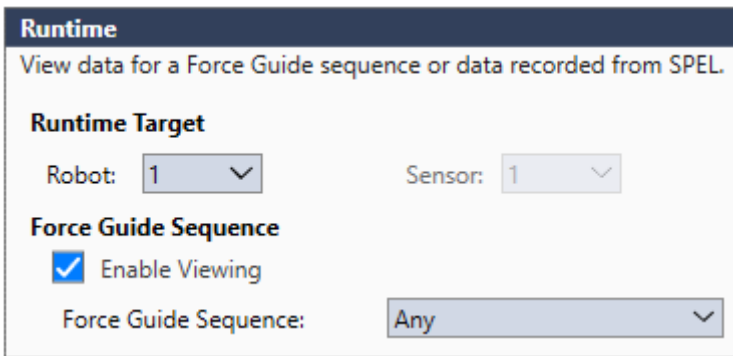

Check the following items: Target robot number or sensor number is correct. Graph display of the record setting by force monitor object, or target force file or force monitor object is correct.

When the setting is correct, execute the record by RecordStart property.

- When the specified force monitor object does not satisfy the condition:
Data is saved in a file, but not displayed on a graph.
- When the specified force monitor object satisfies the condition:
The data is saved in a file, and displayed on a graph.

When the conditions are satisfied, the data is displayed on a graph.

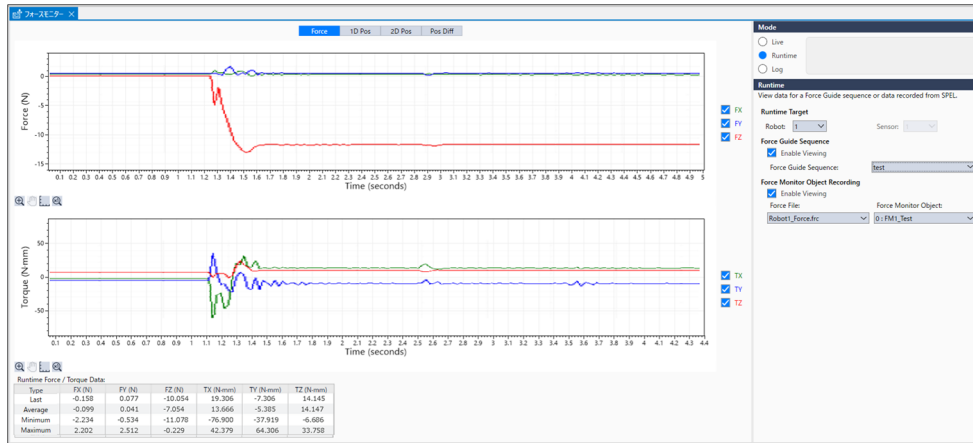

4.3.5.2.3 [Mode]-[Log] button

4.3.5.2.3.1 Details of the displayed dialog box

Select [Mode]-the [Log] button to display the following dialog box.

When the [Single File] button is selected

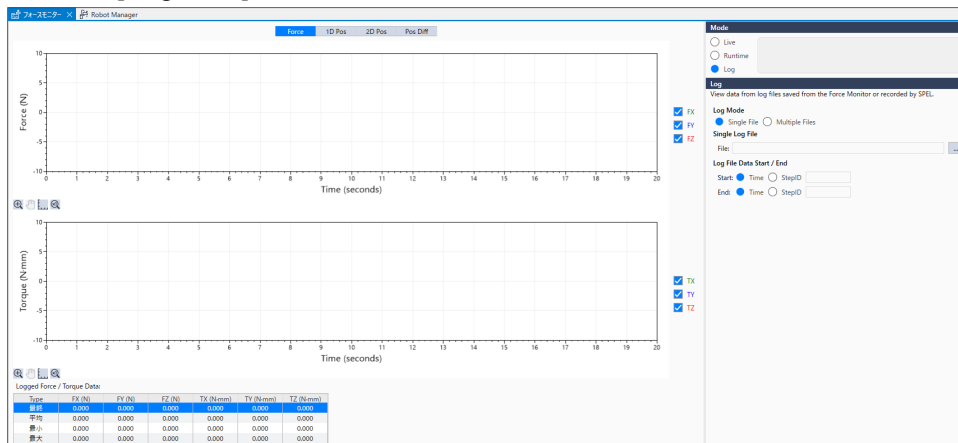

When the [Multiple Files] button is selected

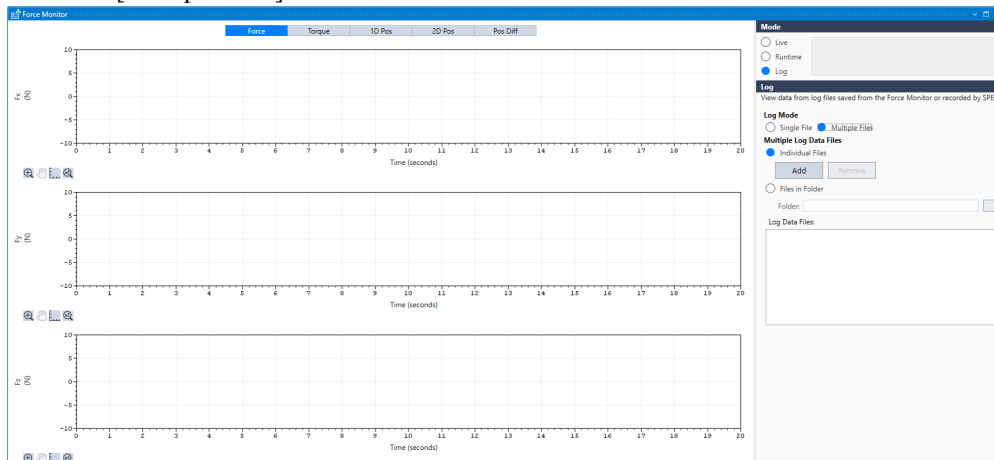

Item	Description
Graph area	Force information or positional information of the robot which is saved in a file is displayed in a graph. You can select several files and compare them on the graph.
	When selecting a single file: There are [Force], [1D Pos], [2D Pos], and [Pos Diff] tabs in graph area.
	When selecting multiple files: There are [Force], [torque], [2D Pos], and [Pos Diff] tabs in the graph area.
	You can switch a tab depending on usage. For details of each tab, refer to the following section. Graph
Single File	Display a single log data file on a graph. You can analyze or check it.
Single Log File	Set a log data file to display. Select a target file from the [Select Data File] dialog box of log data file. Click the [Open] button to display it on a graph.
Log File Data Start / End	Set a display range of the log data. Time : Set a start time or an end time (sec). StepID : Set StepID to start or end.
Multiple Files	Overlay multiple log data files on a graph to display. You can compare them or check variations.
Multiple Log Data Files	You can select the either one of the following loading methods by clicking the [Multiple Files] button. Individual Files Files in Folder
	[Individual Files] button: You can add or remove a target file in a unit of file. [Add] Button The [Select Data File] dialog box is displayed. Select a target file and click the [Open] button to add the file. [Remove] button: Select and click the target files to be removed from a list of log data files. Removal message is displayed. Click the [Yes] button and remove the file.
	[Files in Folder] button: You can select a target file in a unit of folder. Folder: Click the button to display the reference dialog box of the folder. Select a target folder and click the [OK] button to add the file.
	Added file is displayed on the [Log Data Files]. Files with checkmarks are displayed on graph. You can display up to 50 files on a graph simultaneously.

4.3.5.2.3.2 How to Load a Single Log File

1. Select the [Single File] button.

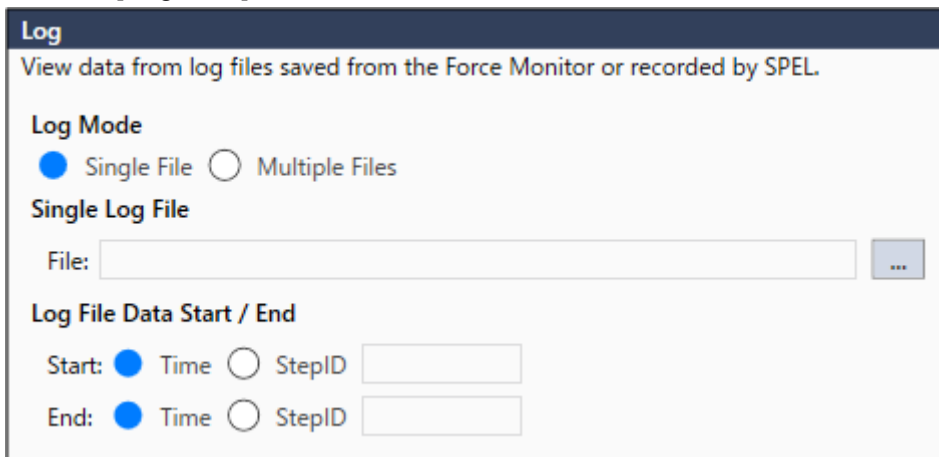

2. Click the button shown below.

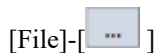

3. The [Select Data File] dialog box is displayed.

Select a target file in the [File name] box.

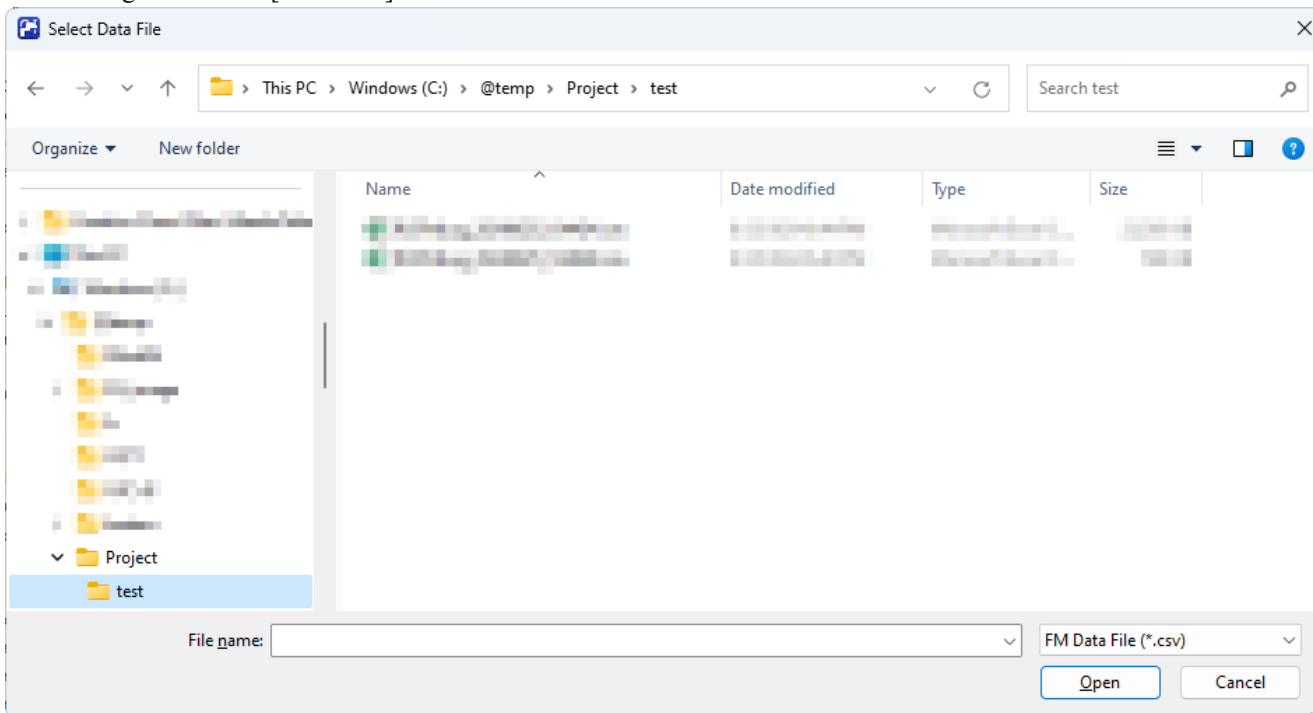

4. Click the [Open] button.

Log data is displayed in the graph.

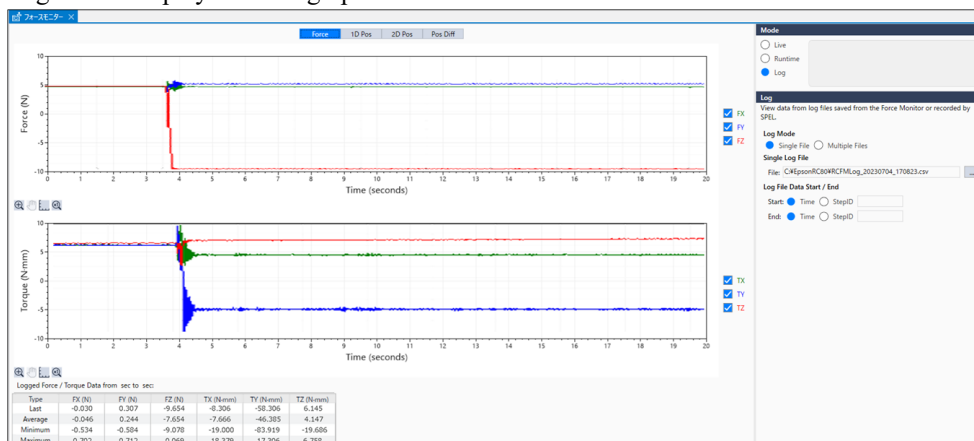

4.3.5.2.3.3 How to Load Multiple Log Data Files

Select individual files

1. Click the [Multiple Files] button.

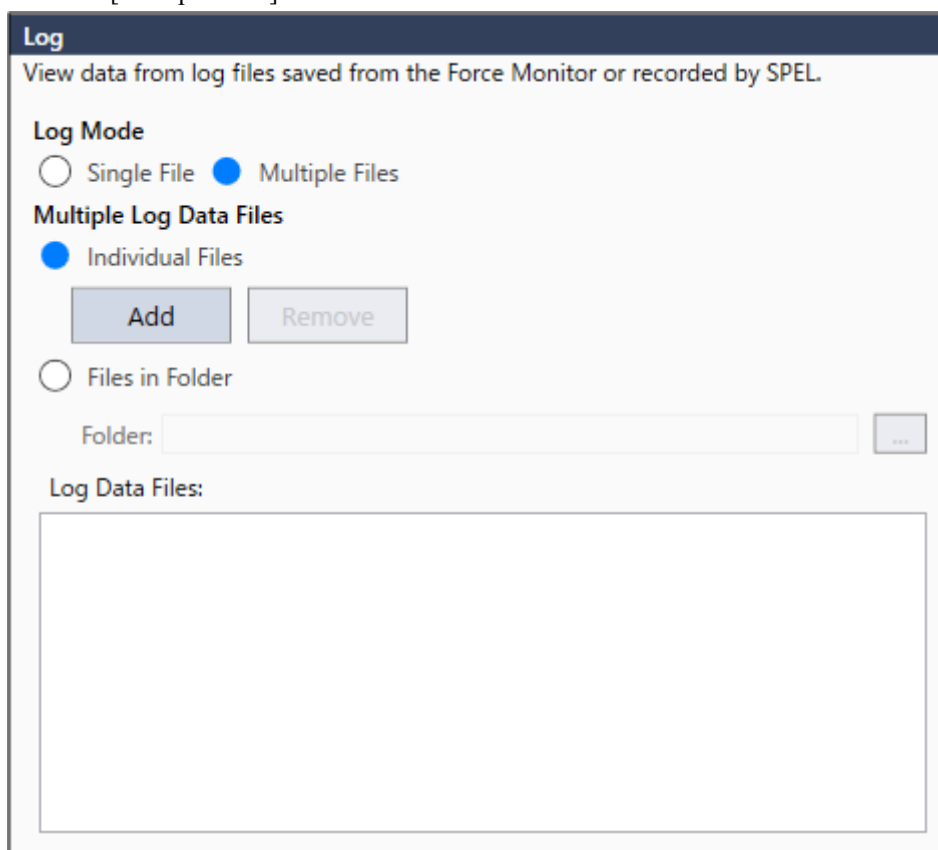

2. Select the [Individual Files] button.

3. Click the [Add] button. The [Select Data File] dialog box is displayed.

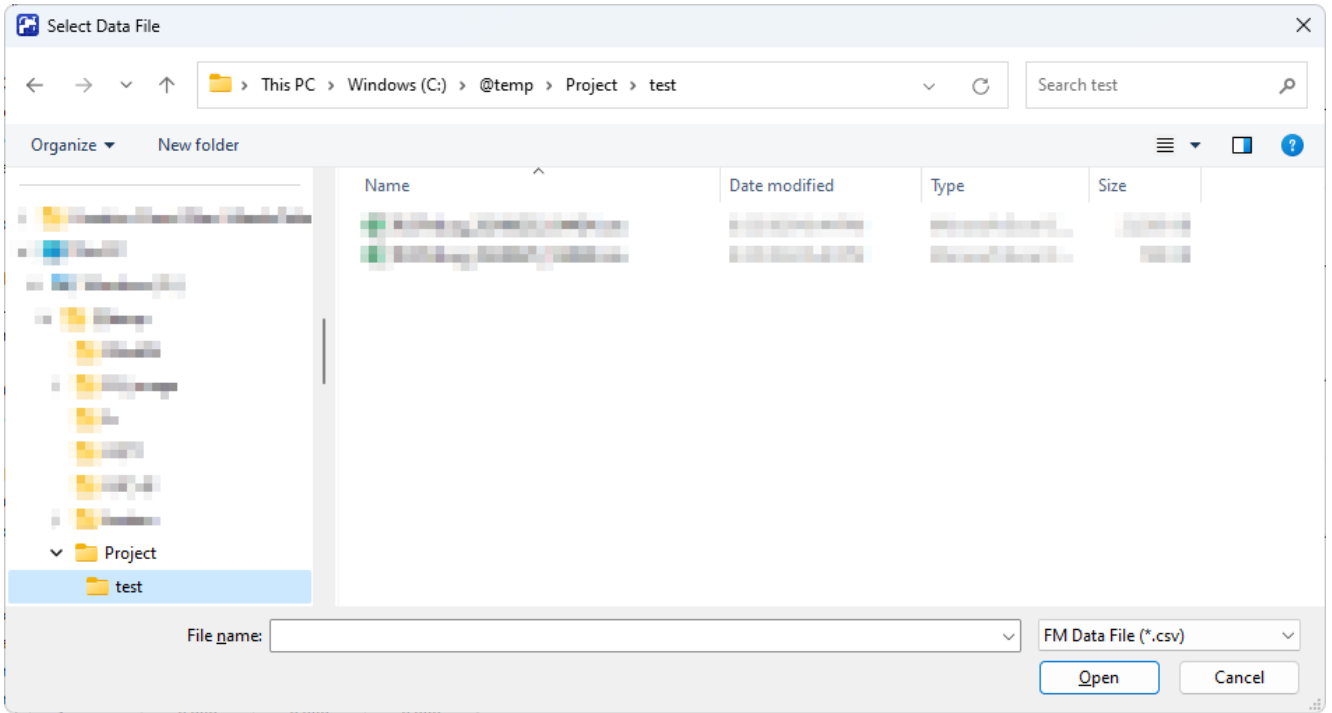

4. Select a target file in the [File name] box.

5. Click the [Open] button.

File is added to the [Log Data Files]. When placing a checkmark in the checkbox, the log data is displayed in the graph.

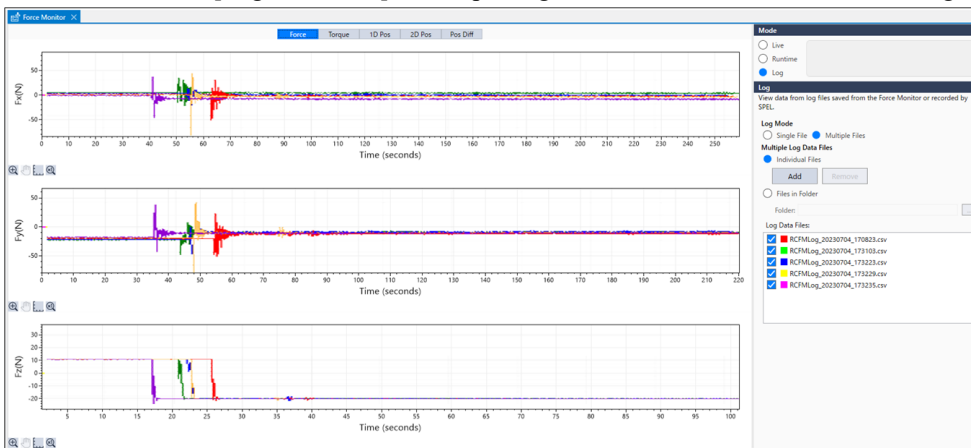

Key Point

When you restart the [Force Monitor] dialog box while the check marks are placed in the checkboxes of the files displayed in [Log Data Files], it will take time to load the files.

- When you want to add files to be displayed on a graph:
Click the [Add] button.
- When you want to remove a file to be displayed from a graph:
There are two methods.
 1. Remove a check mark from the list of [Log Data Files].

2. Select the target file and click the [Remove] button. When you click the [Remove] button, the following message is displayed.

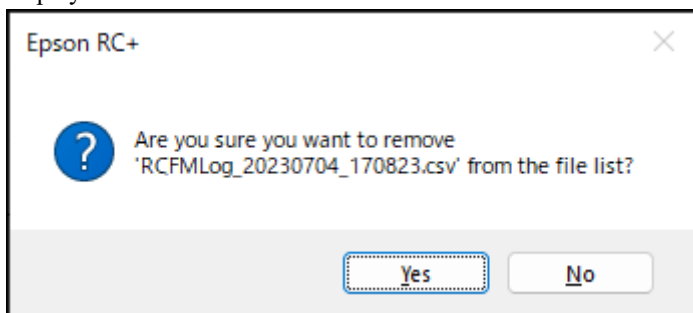

Confirm the message and click the [Yes] button. Target file is removed from the list of [Log Data Files].

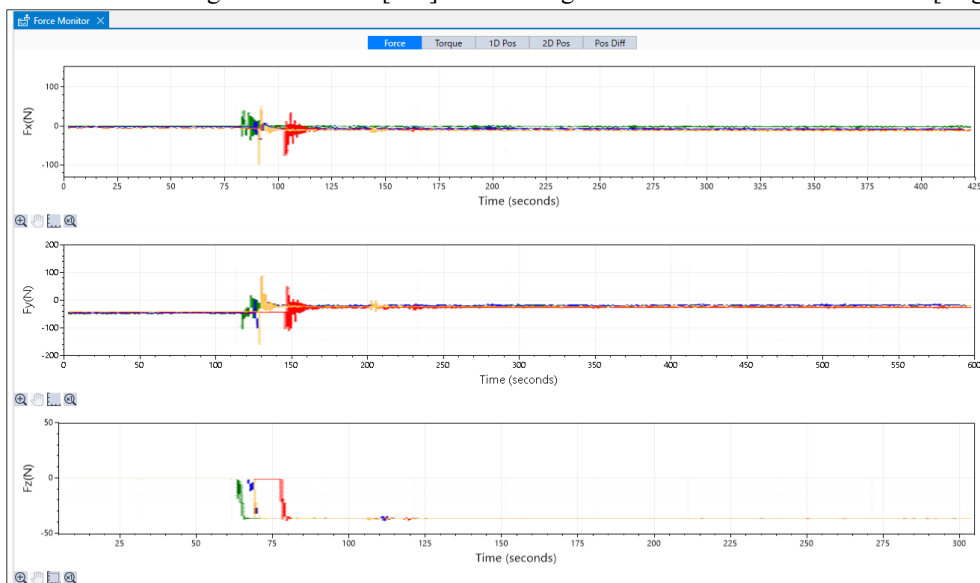

Select a folder

1. Click the [Multiple Files] button.

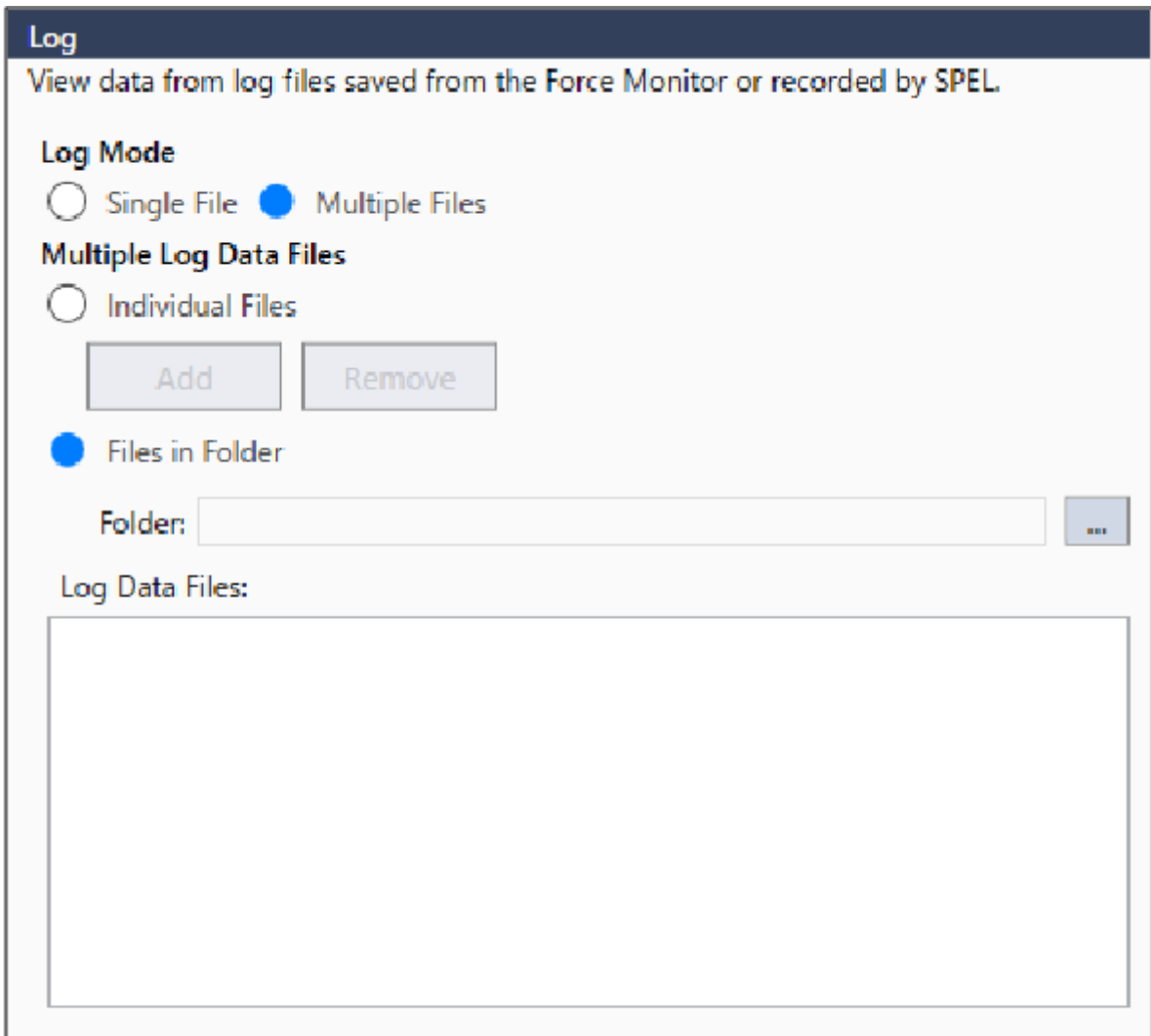

The screenshot shows a dialog box titled "Log" with a subtitle "View data from log files saved from the Force Monitor or recorded by SPEL." Under the "Log Mode" section, the "Multiple Files" radio button is selected. Below this, the "Multiple Log Data Files" section has the "Files in Folder" radio button selected. There are "Add" and "Remove" buttons next to the "Individual Files" option. A "Folder:" text box with a browse button (three dots) is present. At the bottom, there is a "Log Data Files:" label and an empty list box.

2. Click the [Files in Folder] button.
3. Click the button shown below.

[File]-[]

4. The [Browse for Folder] dialog box appears.

Select a target folder.

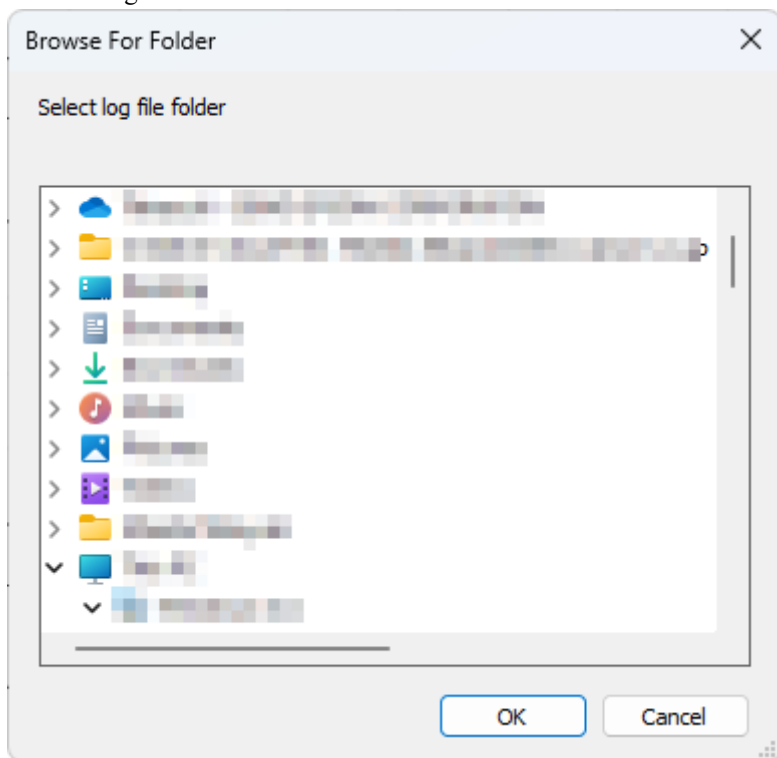

5. Click the [OK] button. File is added to the [Log Data Files].

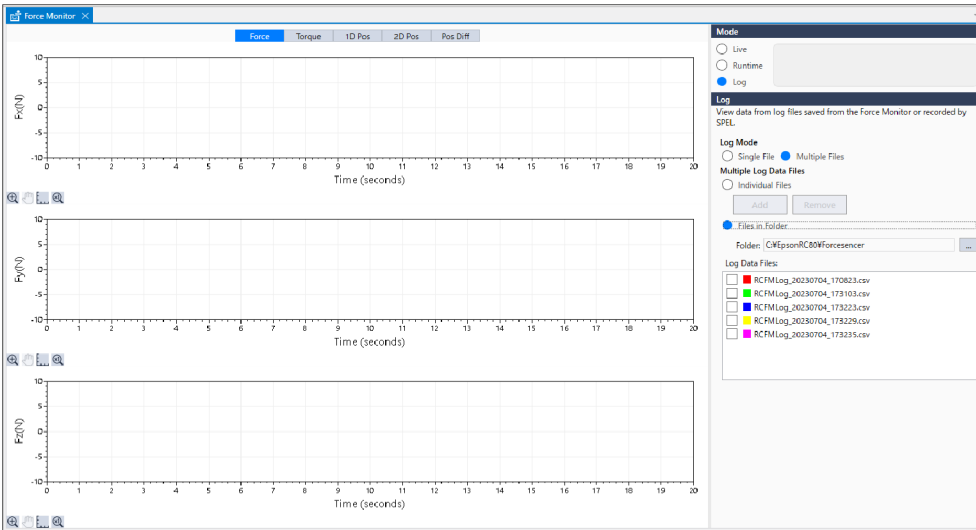

When placing a checkmark in the checkbox, the log data is displayed in the graph.

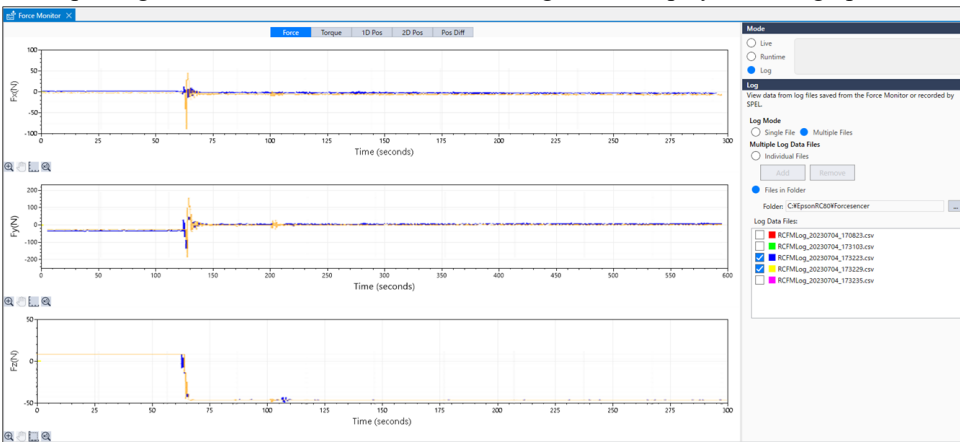

4.3.5.2.4 Graph

Select items to be displayed on the check box next to the graph.

- With a checkmark: Display the selected items in a graph.
- Without a checkmark: The selected items are not displayed in a graph.

4.3.5.2.4.1 Single File

[Force] tab (Single File)

Graph on the [Force] tab displays the translational force, torque and StepID values.

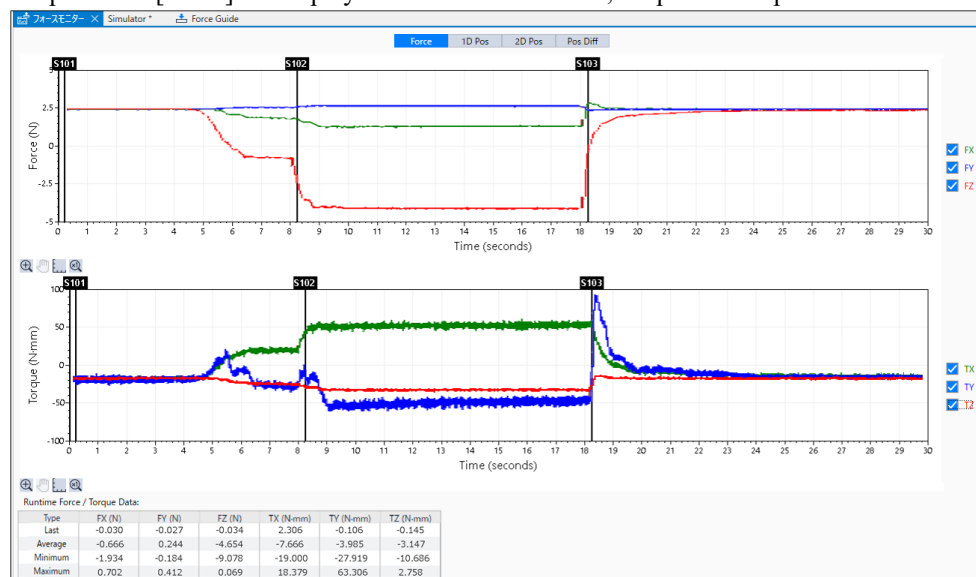

When selecting the [Force] tab in the following modes, the graph is displayed.

- Live mode
- Runtime mode
- Log mode (select the [Single File] button)

Item	Description
Force graph	Display the translational force (Fx, Fy, Fz) in a graph. Vertical axis: Force [N] Horizontal axis: Time [s] Changes of StepID are displayed in a graph with a red line.
Torque graph	Display torque (Tx, Ty, Tz) in a graph. Vertical axis: Torque [N·mm] Horizontal axis: Time [s] Changes of StepID are displayed in a graph with a red line.
Force / Torque Data	For the translational force (Fx, Fy, Fz) and torque (Tx, Ty, Tz), display the values (last, average, minimum, and maximum) of the data displayed in a graph.

[1D Pos] tab (Single File)

The graphs on the [1D Pos] tab display the (CurPos) command position (which includes force control) and the (RefPos) command position (which includes only position control), divided into their X, Y, and Z components.

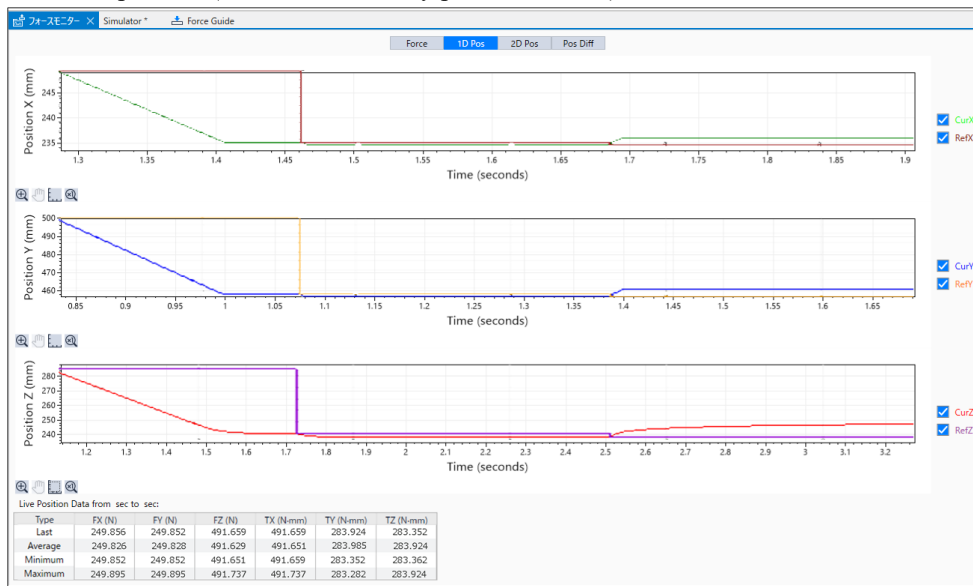

When selecting the [1D Pos] tab in the following modes, the graph is displayed.

- Live mode
- Runtime mode
- Log mode (select the [Single File] button)

Item	Description
Position X graph	Display the command positions (CurPos and RefPos) in X direction in a graph. Vertical axis: Position in X direction [mm] Horizontal axis: Time [s]
Position Y graph	Display the command positions (CurPos and RefPos) in Y direction in a graph. Vertical axis: Position in Y direction [mm] Horizontal axis: Time [s]
Position Z graph	Display the command positions (CurPos and RefPos) in Z direction in a graph. Vertical axis: Position in Z direction [mm] Horizontal axis: Time [s]
Position Data	For each component of X, Y, and Z of each command position, display the values (last, average, minimum, and maximum) of the data displayed in a graph.

[2D Pos] tab (Single File)

The graphs on the [2D Pos] tab displays graphs of the (CurPos) command position (which includes force control) and the (RefPos) command position (which includes position control only), divided into XY, YZ, and XZ planes.

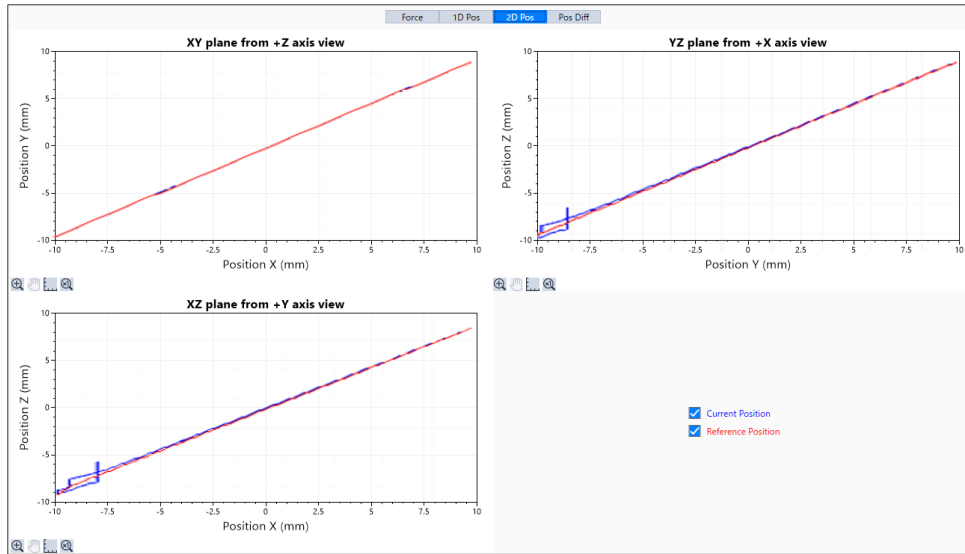

When selecting the [2D Pos] tab in the following mode, the graph is displayed.

- Live mode
- Runtime mode
- Log mode (select the [Single File] button)

Item	Description
XY plane from +Y axis view graph	Display the command positions (CurPos and RefPos) projected on XY plane in a graph. Vertical axis: Position in Y direction [mm] Horizontal axis: Position in X direction [mm]
YZ plane from +Y axis view graph	Display the command positions (CurPos and RefPos) projected on YZ plane in a graph. Vertical axis: Position in Z direction [mm] Horizontal axis: Position in Y direction [mm]
XZ plane from +Y axis view graph	Display the command positions (CurPos and RefPos) projected on XZ plane in a graph. Vertical axis: Position in Z direction [mm] Horizontal axis: Position in X direction [mm]
Command Position	You can select command positions to be displayed in the right bottom check boxes (Current Position and Reference Position). With a checkmark: Display the selected command positions in a graph. Without a checkmark: The selected command positions are not displayed in a graph. This setting is reflected to all graphs.

[Pos Diff] tab (Single File)

Graph on the [Pos Diff] tab displays the difference between the command position (CurPos) including force control and the command position (RefPos) only including position control on the graph by dividing them into each component: X, Y, and Z.

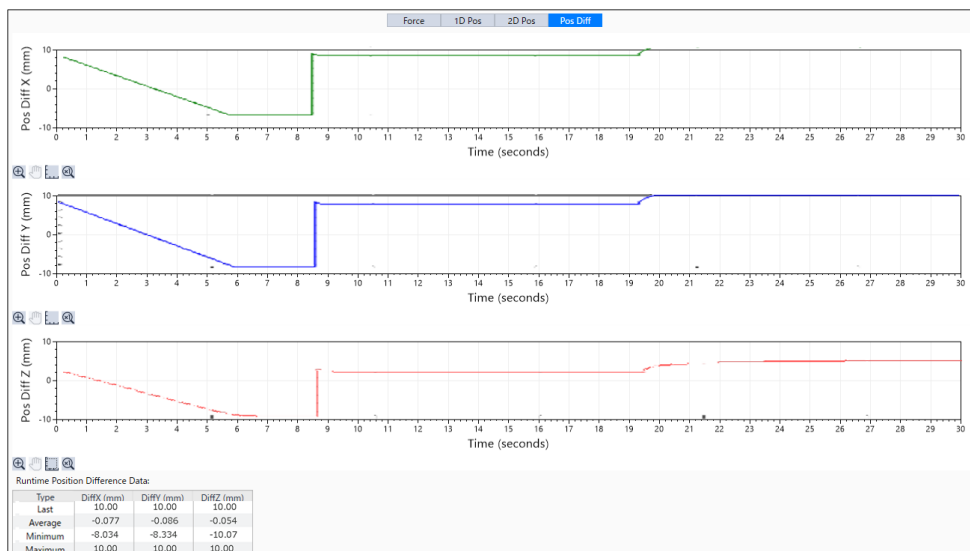

When selecting the [Pos Diff] tab in the following modes, the graph is displayed.

- Live mode
- Runtime mode
- Log mode (select the [Single File] button)

Item	Description
Pos Diff X graph	Display the position difference of the command positions (CurPos and RefPos) in the X direction in a graph. Vertical axis: Positional difference in X direction [mm] Horizontal axis: Time [s]
Pos Diff Y graph	Display the position difference of the command positions (CurPos and RefPos) in the Y direction in a graph. Vertical axis: Positional difference in Y [mm] Horizontal axis: Time [s]
Pos Diff Z graph	Display the position difference of the command positions (CurPos and RefPos) in the Z direction in a graph. Vertical axis: Positional difference in Z [mm] Horizontal axis: Time [s]
Position Difference Data	For each component of Pos Diff: X, Y, and Z, display the values (last, average, minimum, and maximum) of the data displayed in a graph.

4.3.5.2.4.2 Multiple Files

[Force] tab (Multiple Files)

Graph on the [Force] tab (multiple files) displays the translational force on a graph for each axis. Data of multiple log data files which are specified on each graph is overlaid to display.

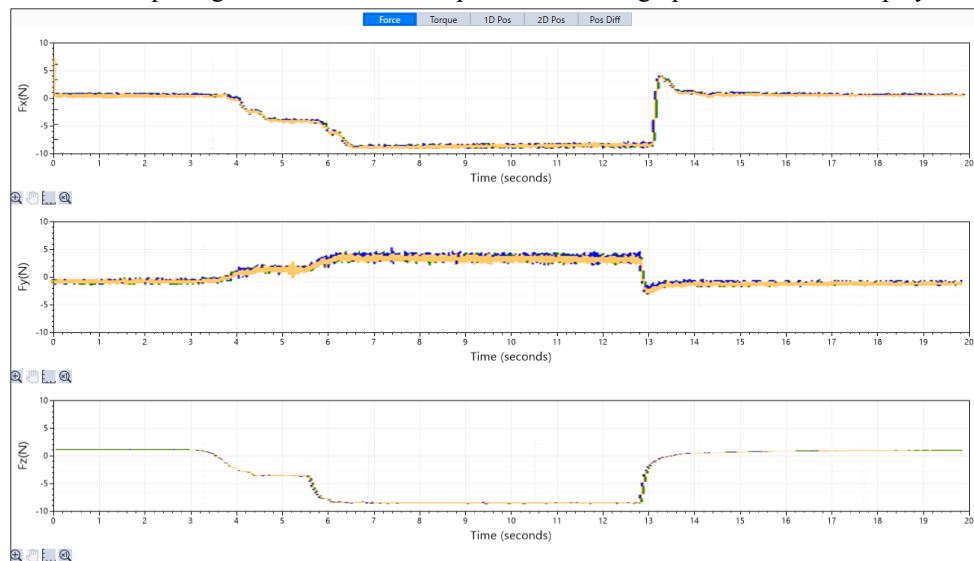

When selecting the [Force] tab in the following modes, the graph is displayed.

- Log mode (select the [Multiple Files] button)

Item	Description
Fx graph	Overlay the translational force in X direction up to 50 files on the graph and display. Vertical axis: Force in X direction [N] Horizontal axis: Time [s]
Fy graph	Overlay the translational force in Y direction up to 50 files on the graph and display. Vertical axis: Force in Y direction [N] Horizontal axis: Time [s]
Fz graph	Overlay the translational force in Z direction up to 50 files on the graph and display. Vertical axis: Force in Z direction [N] Horizontal axis: Time [s]

[Torque] tab (Multiple Files)

Graph on the [Torque] tab displays the torque on a graph for each axis. Data of multiple log data files which are specified on each graph is overlaid to display.

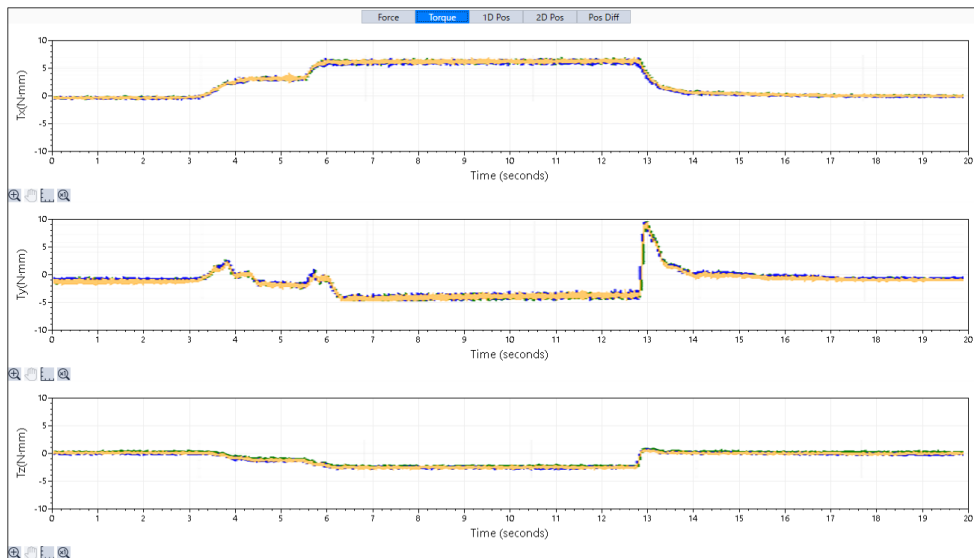

When selecting the [Torque] tab in the following mode, the graph is displayed.

- Log mode (select the [Multiple Files] button)

Item	Description
Tx graph	Overlay the torque in X direction up to 50 files on the graph and display. Vertical axis: Torque in X direction [N · mm] Horizontal axis: Time [s]
Ty graph	Overlay the torque in Y direction up to 50 files on the graph and display. Vertical axis: Torque in Y direction [N · mm] Horizontal axis: Time [s]
Tz graph	Overlay the torque in Z direction up to 50 files on the graph and display. Vertical axis: Torque in Z direction [N · mm] Horizontal axis: Time [s]

[1D Pos] Tab (Multiple Files)

The graphs on the [1D Pos] tab display the (CurPos) command position (which includes force control) and the (RefPos)

command position (which includes only position control), divided into their X, Y, and Z components. Data of multiple log data files which are specified on each graph is overlaid to display.

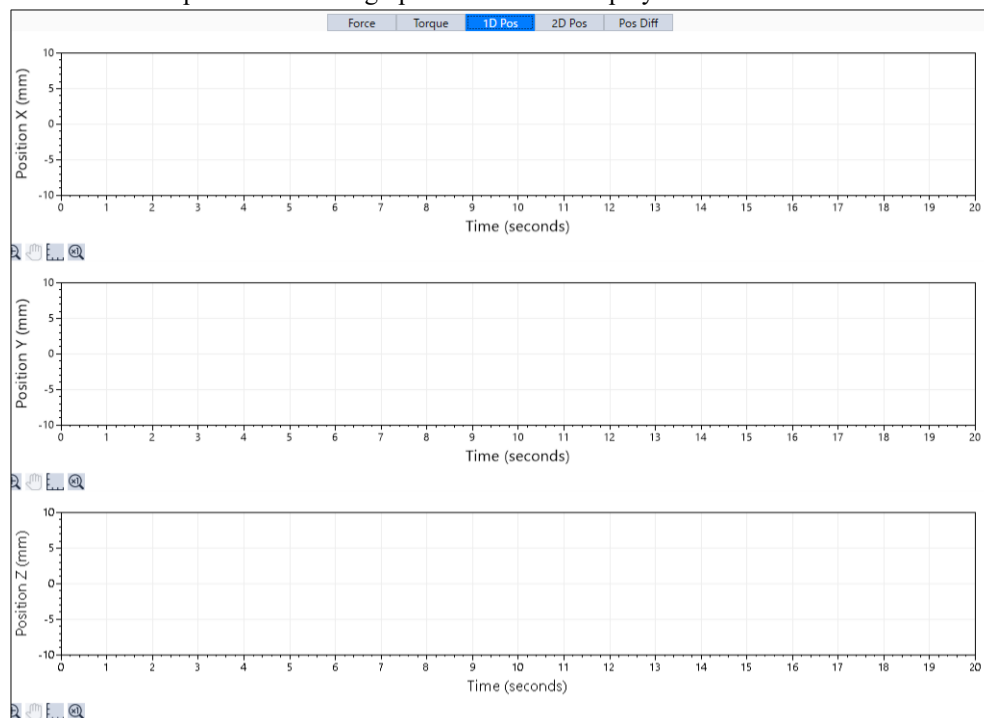

When selecting the [1D Pos] tab in the following modes, the graph is displayed.

- Log mode (select the [Multiple Files] button)

Item	Description
Position X graph	Overlay the command positions (CurPos and RefPos) in X direction up to 50 files on the graph and display. Vertical axis: Position in X direction [mm] Horizontal axis: Time [s]
Position Y graph	Overlay the command positions (CurPos and RefPos) in Y direction up to 50 files on the graph and display. Vertical axis: Position in Y direction [mm] Horizontal axis: Time [s]
Position Z graph	Overlay the command positions (CurPos and RefPos) in Z direction up to 50 files on the graph and display. Vertical axis: Position in Z direction [mm] Horizontal axis: Time [s]

[2D Pos] Tab (Multiple Files)

The graphs on the [2D Pos] tab displays graphs of the (CurPos) command position (which includes force control) and the

(RefPos) command position (which includes position control only), divided into XY, YZ, and XZ planes. Data of multiple log data files which are specified on each graph is overlaid to display.

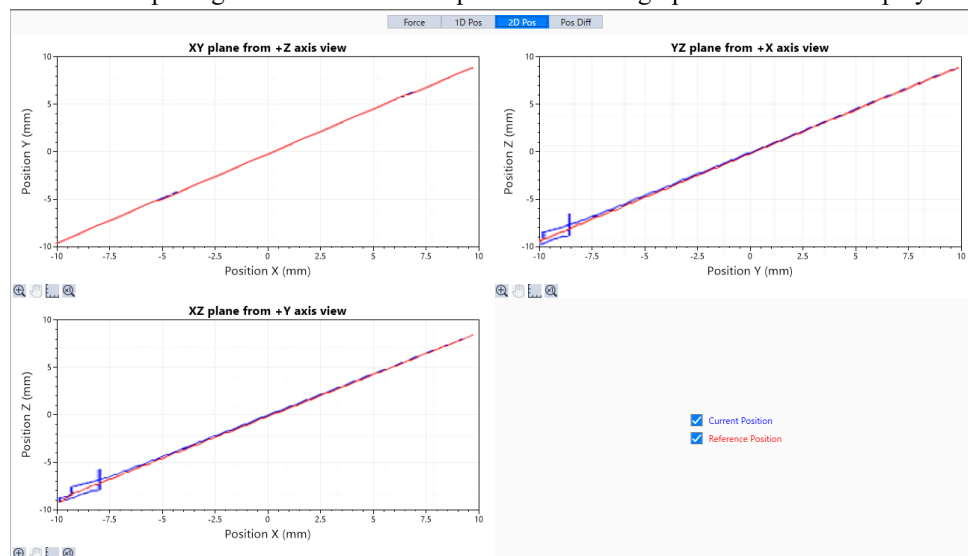

When selecting the [2D Pos] tab in the following mode, the graph is displayed.

- Log mode (select the [Multiple Files] button)

Item	Description
XY plane from +Y axis view graph	Display the command positions (CurPos and RefPos) projected on the XY plane by overlaying up to 50 files on the graph. Vertical axis: Position in Y direction [mm] Horizontal axis: Position in X direction [mm]
YZ plane from +Y axis view graph	Display the command positions (CurPos and RefPos) projected on the YZ plane by overlaying up to 50 files on the graph. Vertical axis: Position in Z direction [mm] Horizontal axis: Position in Y direction [mm]
XZ plane from +Y axis view graph	Display the command positions (CurPos and RefPos) projected on the XZ plane by overlaying up to 50 files on the graph. Vertical axis: Position in Z direction [mm] Horizontal axis: Position in X direction [mm]

[Pos Diff] tab (Multiple Files)

Graph of the [Pos Diff] tab (Multiple Files) displays the difference between the command position (CurPos) including force control and the command position (RefPos) only including position control on the graph by dividing them into each

component: X, Y, and Z.

Data of multiple log data files which are specified on each graph is overlaid to display.

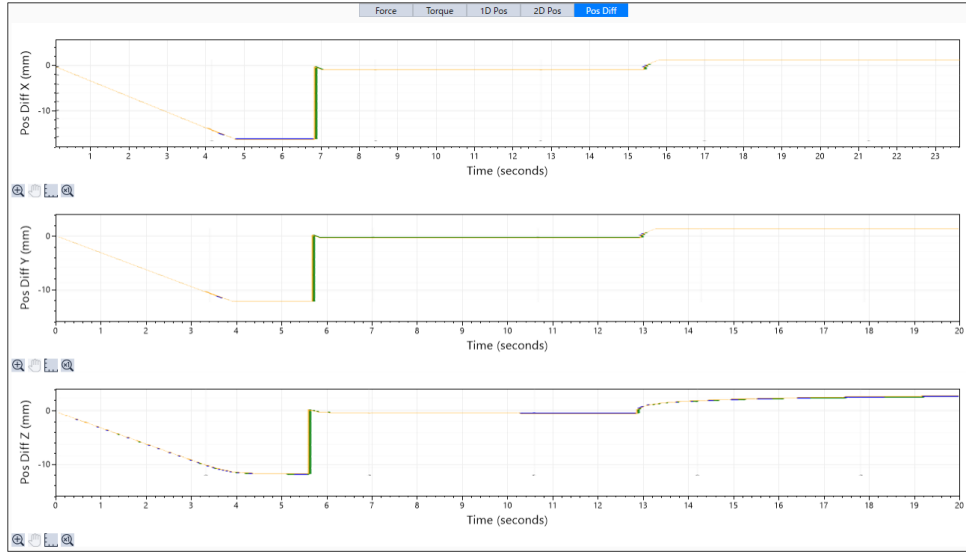

When selecting the [Pos Diff] tab in the [Log] mode which selected several files, the graph is displayed.

Item	Description
Pos Diff X graph	Display the positional difference of the command positions (CurPos and RefPos) in X direction by overlaying up to 50 files on the graph. Vertical axis: Positional difference in X direction [mm] Horizontal axis: Time [s]
Pos Diff Y graph	Display the positional difference of the command positions (CurPos and RefPos) in Y direction by overlaying up to 50 files on the graph. Vertical axis: Positional difference in Y [mm] Horizontal axis: Time [s]
Pos Diff Z graph	Display the positional difference of the command positions (CurPos and RefPos) in Z direction by overlaying up to 50 files on the graph. Vertical axis: Positional difference in Z [mm] Horizontal axis: Time [s]







4.3.5.2.4.3 Common functions

There are the following functions common for each graph.

- Enlarged display of graph
- Move an enlarged area
- Change of graph scale
- Display default size of graph

You can use the above functions when the graph is not updating.



Item	Description
Enlarged display of graph	<p>Click the  button and move the mouse cursor over the graph.</p> <p>When the cursor moves over the graph, it changes to a cross-hair cursor.</p> <p>Then, an area from the start position to the end position will be enlarged.</p> <p>To return to the original graph, click the  button again.</p> <p>Instead of clicking button, you can display enlarged graph by rolling the mouse wheel on the graph.</p> <p>Also while clicking the mouse wheel on the graph and moving left and right, up and down, the graph is enlarged for each axis.</p>
Move an enlarged area	<p>Click the  button and move the mouse cursor over the graph.</p> <p>When the cursor moves on the graph, it changes to an arrow cursor.</p> <p>While left-clicking the enlarged area and moving left and right, up and down, the area moves with the mouse motion.</p> <p>Instead of clicking button, while right-clicking the mouse on the graph and moving left and right, up and down, the enlarged area moves with the mouse motion.</p>
Change of graph scale	<p>When the () is clicked, the [Set Graph Axis Scales] dialog box is displayed. You can select the scale of each axis.</p> <p>When set to "Auto", the scale changes automatically depending on the values.</p>
Display default size of graph	<p>If you click the  button with the Enlarge Graph button  not pressed, the enlarged graph is returned to its default display status when you right-click the mouse and move the cursor, or when you use the mouse wheel.</p> <p>Instead of clicking button, double-click the right mouse button on the graph to show the default size of the graph in the same way as clicking the enlarge graph button.</p>

Enlarge a graph

The following describes steps to enlarge the following ranges for the following graph. From -6.00N to -4.00N From 5 to 6sec

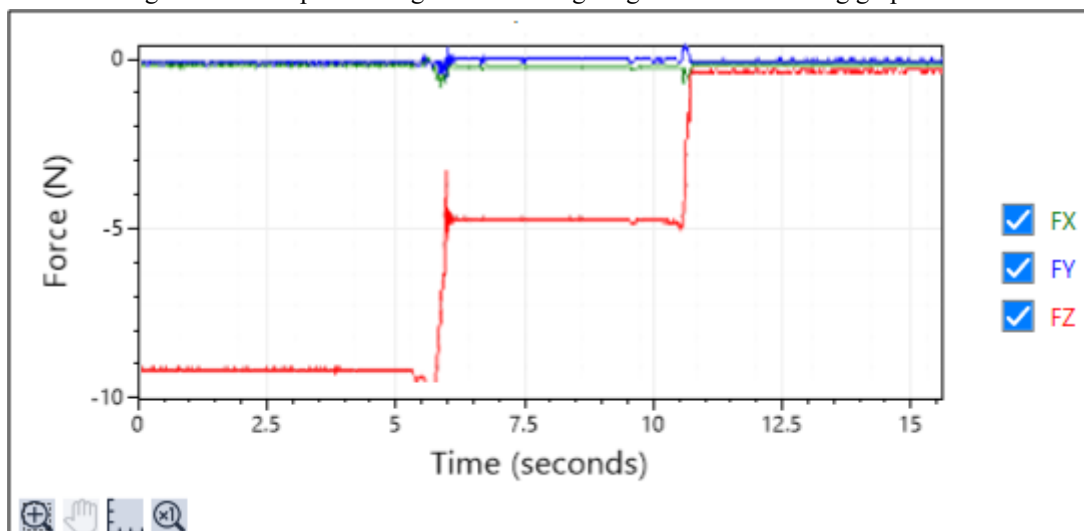

Method 1: Using the enlarge graph button 

Click the  button. When you click the button, it will change. (It shows the selected status.)



1. Move the mouse cursor over the graph.

- To select the area you want to enlarge, left-click the start position (5sec, -4.00N) and with the left mouse button held down, drag the cursor to the end position (6sec, -6.00N).
- Release the left mouse button. Display is switched to a range selected in the step (3).

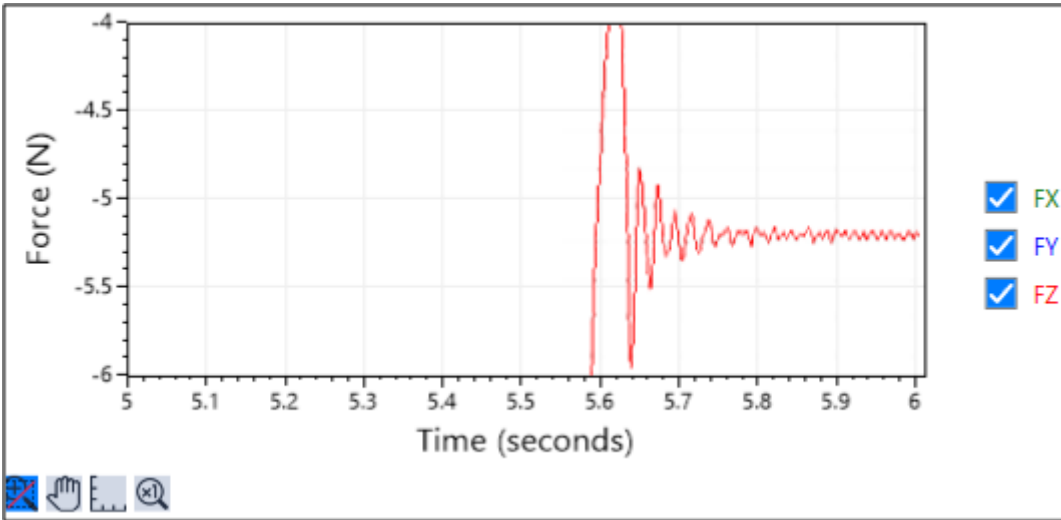

Method 2: Using mouse wheel

- Roll the mouse wheel on the graph.
- Centered on the cursor position, the graph expands according to the rotation of the mouse wheel.
Also while clicking the mouse wheel on the graph and moving left and right, up and down, the graph is enlarged for each axis according to the movement of the mouse.

Move an enlarged area

The following describes steps to move the display range for the graph enlarged in the example of "Enlarge a graph".

Method 1: Using the move an enlarged area button 

- Click the  button.
When you click the button, it will change. (It shows the selected status.)



- Move the mouse cursor over the graph.
- Move the mouse to any position while left-clicking.
- Release the left mouse button. Display is switched to a position where is moved in the step (3).

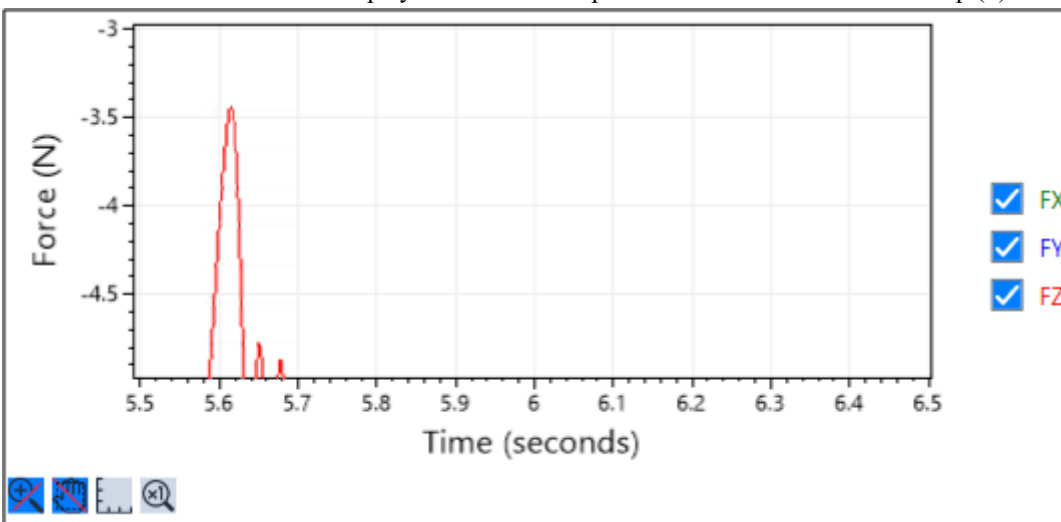



Method 2: Using right-click

1. Move the mouse cursor over the graph.
2. Move the mouse to any position while right-clicking, and the enlarged area moves with the mouse motion.

Example of changing a graph scale

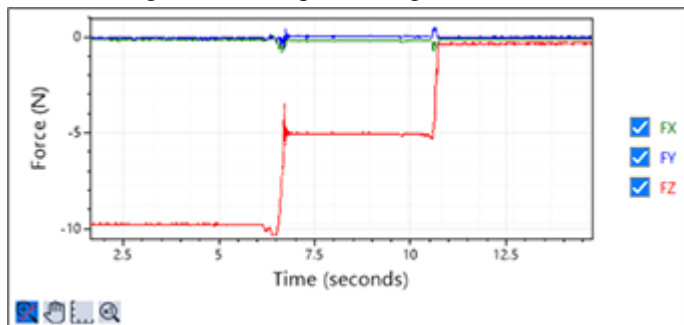
The following describes steps to change the force scale to 10N and the time scale to 10sec for the following graph.



1. Click the  button. The [Set Graph Axis Scales] dialog box is displayed.

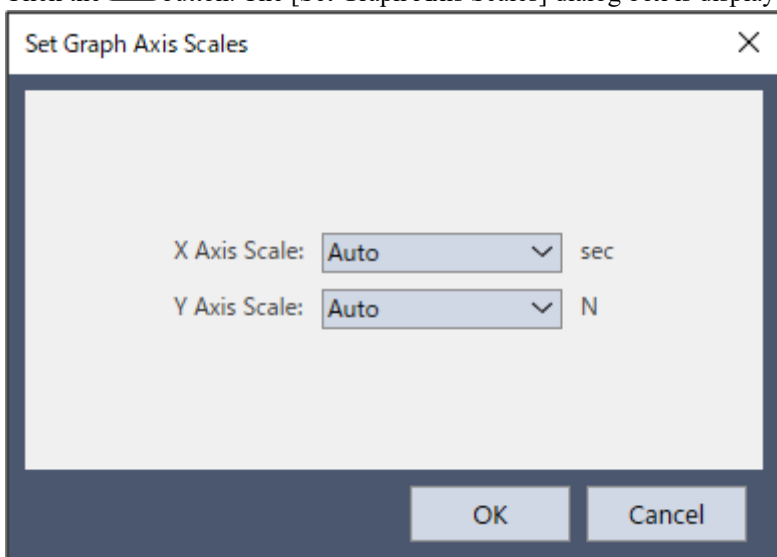

2. Change the [Y Axis Scale] (force scale) to "10" and the [X Axis Scale] (time scale) to "10".

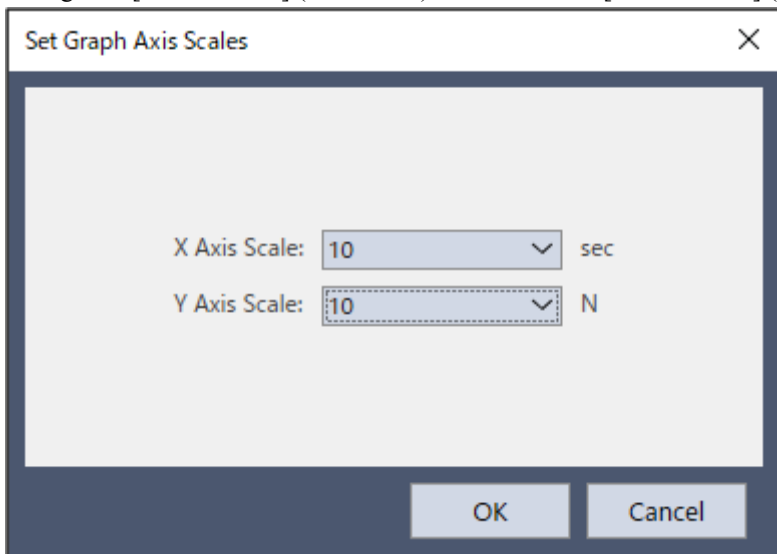

3. Click the [OK] button. Display changes to the specified scale.

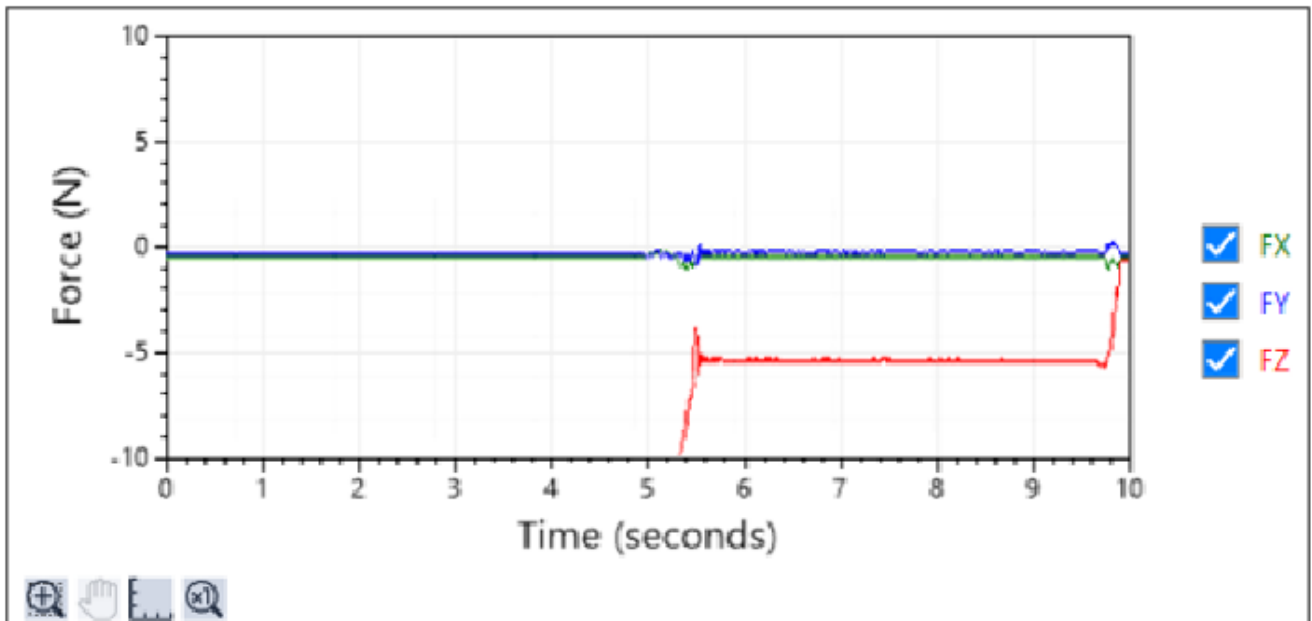

Restore the enlarged graph to its default display

The following explains how to restore the enlarged graph to its default display after enlarging the graph or moving the enlarged area.

1. If the is selected, click the button to deselect it and return the graph display to its default.



2. If the button is not selected, click the to return the graph display to its default.

3. Double-click the right mouse button on the graph to return the graph display to its default.

4.3.5.3 [Maintenance] (Tools Menu)

Force Sensor-related values can be referred to when displaying the Controller status.

1. Click the [View Controller Status] button.

The [Browse Folder] dialog box appears.

2. Select the folder in which the information is stored. (The folder with "controller type name, serial number, and date/time" after "B_")

3. Click the [OK] button to display the Controller status.

4. From the tree in the [Controller Status Viewer] window, select [Robots]-[Robot*]. The property values of GravityDirection and Mass Properties (mass property object) of the selected robot (robot object) are displayed.

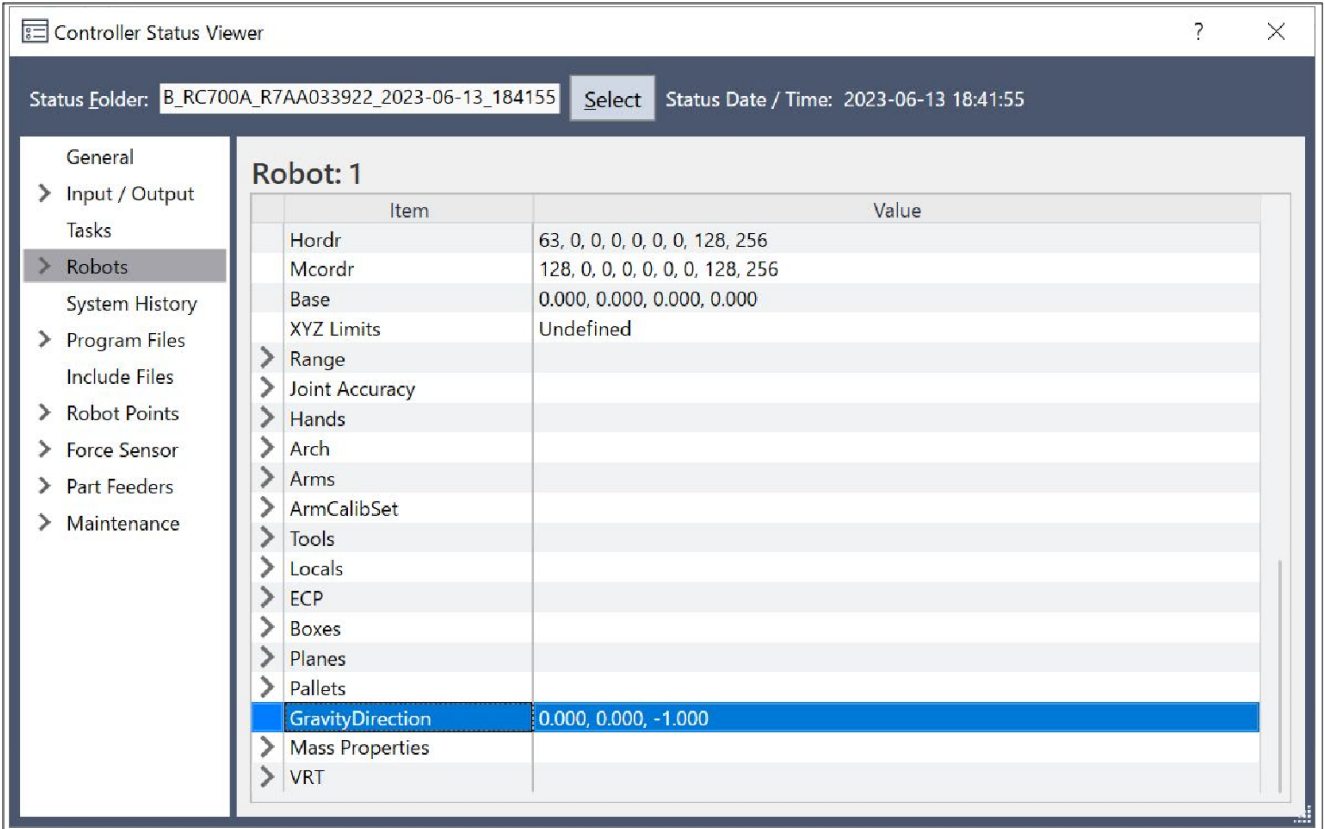

5. Select [Force]-[Robot*]-[****.frc].

The values of the selected force object and properties are displayed.

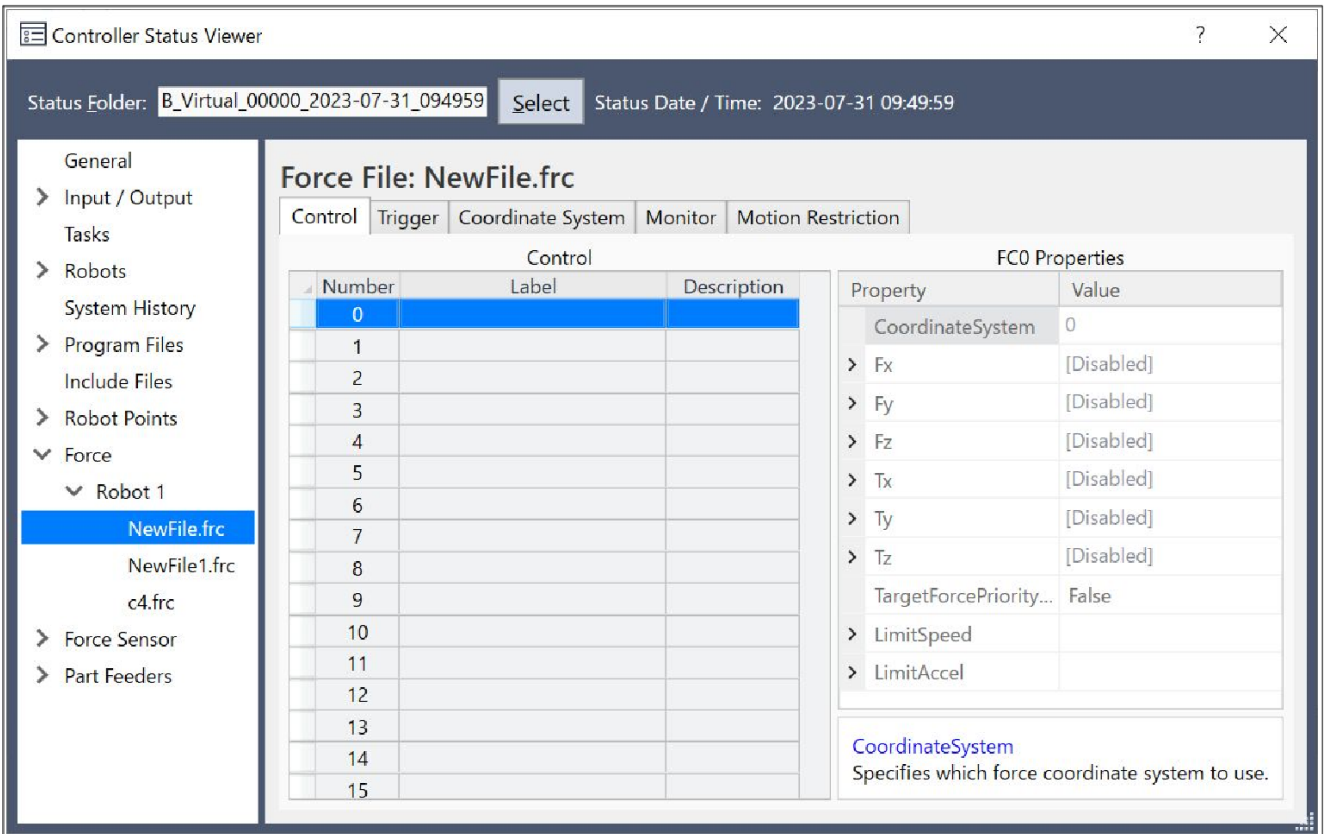

For the details, refer to the following section.

Software [\[Robot Manager\] \(Tools Menu\)](#)

- [Tools]-[Robot Manager]-[Force] Panel

6. Select [Force Sensor]- [Sensor*]. The values of the selected Force Sensor and FlangeOffset are displayed.

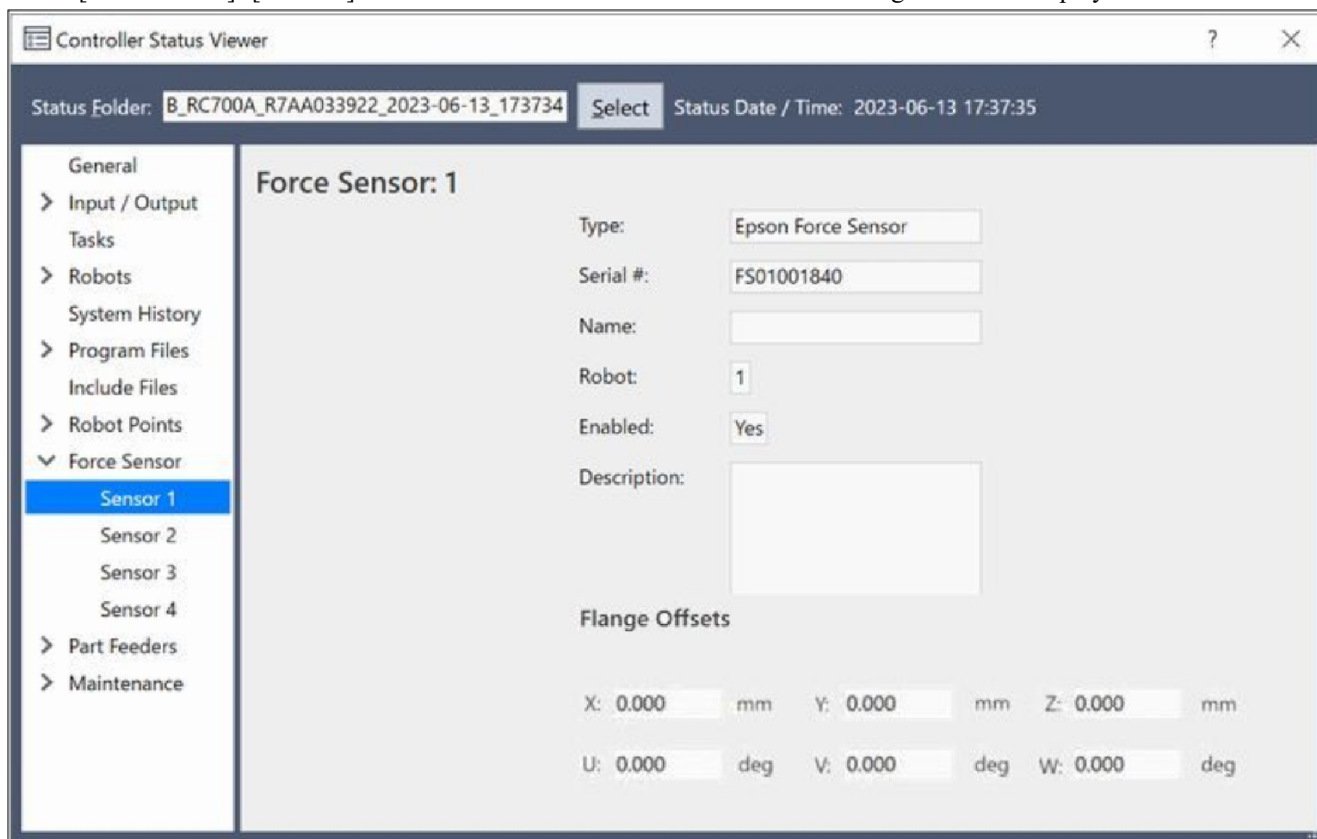

For the details, refer to the following section.

Software [Configuring the Force Sensor Unit](#)

4.3.5.4 [Force Guidance] (Tools Menu)

You can create an operation using the force control function, force trigger function, and force monitor function without programming by SPEL+ language.

[Force Guide] window display

There are the following two ways to display the [Force Guide] window.

1. Select Epson RC+ 8.0 - menu-[Tools]- [Force Guide].

2. Click Tool Bar the [The [Force Guide] .

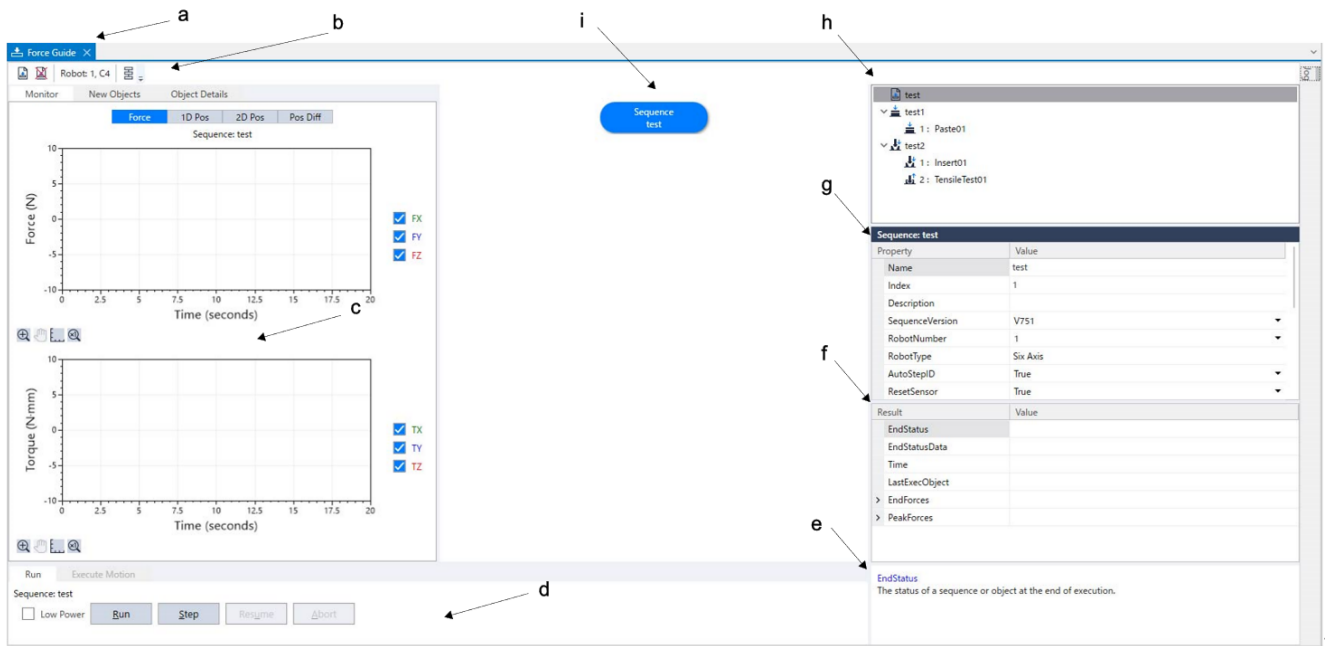

Symbol	Item
a	Force Guide Title Bar
b	Force Guide Toolbar
c	Main Window
d	Run panel
e	Description window
f	Result window
g	Property window
h	Sequence tree
i	Flow chart

Force Guide Title Bar

Title bar shows the window title and a name of currently selected force guide sequence. The force guide sequence name is displayed with [bracket].

When the force guide sequence is updated, "*" is displayed next to the [bracket]. When it saved, "*" is disappeared.

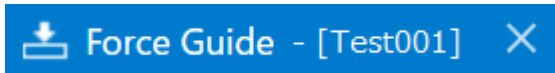

bar of Epson RC+ 8.0 and that of Force Guide are different. note that

Difference:

- Epson RC+ 8.0 title bar :
Working project name is displayed.
- Force Guide title bar :
The name of the currently selected force guide sequence is displayed.

Force Guide Toolbar

Force Guide toolbar is displayed above the Force Guide window and under the title bar.



Item	Tool tip	Description
	New sequence	Creates a force guide sequence. Click it to display the sequence wizard. To create a force guide sequence, set basic information, select tasks, and select a template according to the sequence wizard. Reference: Create a new force guide sequence (describe in a later page)
	Delete sequence	Deletes a force guide sequence. Click it to display the [Delete Force Guide Sequence] dialog box. To delete the force guide sequence, select the force guide sequence to delete on the dialog box. Reference: Delete a force guide sequence (describe in a later page)
Robot	-	Display a target robot number and robot name.
	Flow chart ON/OFF	Switches the flow chart display ON/OFF on the force guide sequence.

Main Window

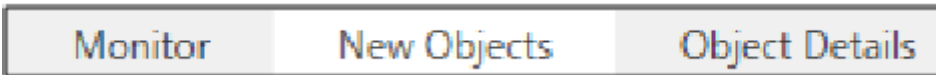

The main window can switch the displays by the following tabs:

Monitor tab : Display the data when executing the force guide sequence.

New Objects tab : Select the force guide objects to be added to the force guide sequence.

Object Details tab : Set or check a currently selected force guide sequence or force guide object.

Brief describes about each function are as follows:

- [Monitor] tab

Monitor tab has [Force], [1D Pos], [2D Pos], and [Pos Diff] tabs.

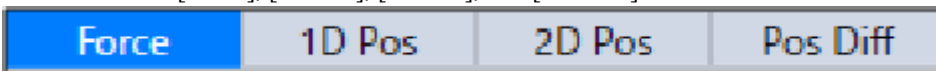

- [Force] tab

Translational force and torque are displayed in each graph.

Select items to be displayed on the check box next to the graph.

- With a checkmark: Display the selected items in a graph.
- Without a checkmark: The selected items are not displayed in a graph.

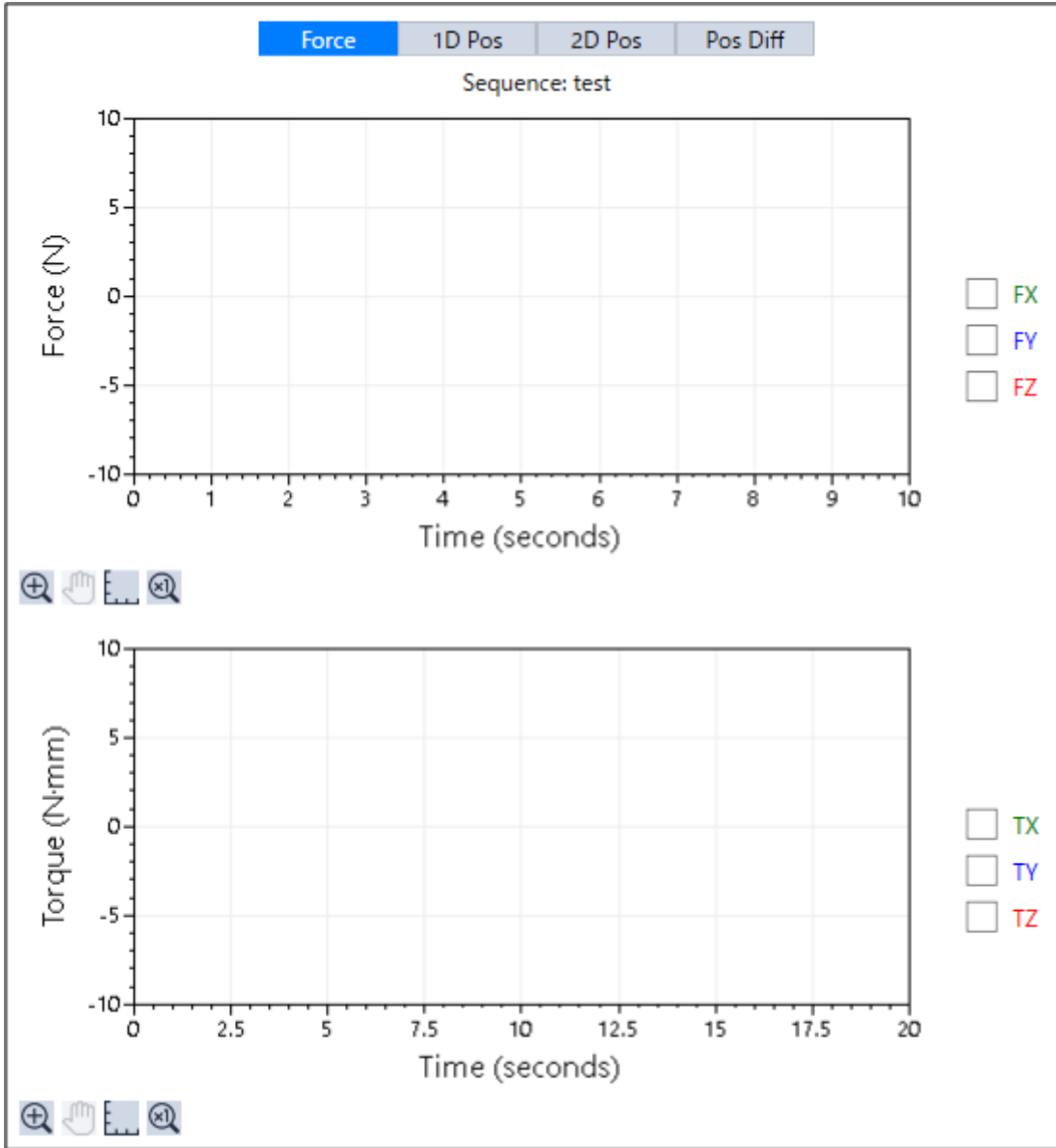

Item	Description
Force graph	Display the translational force (Fx, Fy, Fz) in a graph. Vertical axis: Force [N] Horizontal axis: Time [s]
Torque graph	Display torque (Tx, Ty, Tz) in a graph. Vertical axis: Torque [N · mm] Horizontal axis: Time [s]

- [1D Pos] tab

Display the command position (CurPos) including force control and the command position (RefPos) only including position control on the graph by dividing them into X, Y, and Z components.

Select items to be displayed on the check box next to the graph.

- With a checkmark: Display the selected items in a graph.
- Without a checkmark: The selected items are not displayed in a graph.

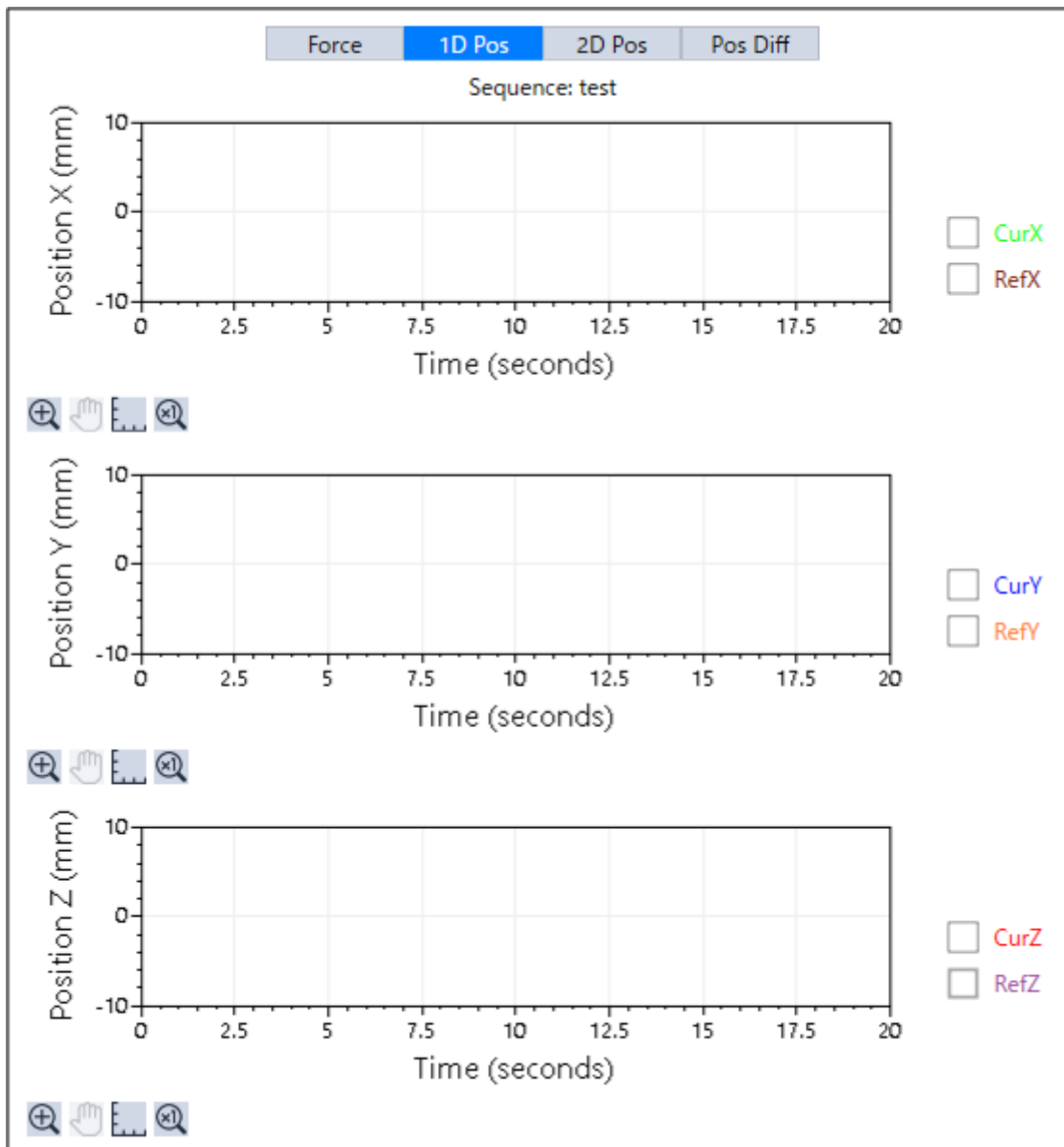

Item	Description
Position X graph	Display the command positions (CurPos and RefPos) in X direction in a graph. Vertical axis: Position in X direction [mm] Horizontal axis: Time [s]
Position Y graph	Display the command positions (CurPos and RefPos) in Y direction in a graph. Vertical axis: Position in Y direction [mm] Horizontal axis: Time [s]
Position Z graph	Display the command positions (CurPos and RefPos) in Z direction in a graph. Vertical axis: Position in Z direction [mm] Horizontal axis: Time [s]

- [2D Pos] tab

Display the command position (CurPos) including force control and the command position (RefPos) only including position control on the graph by dividing them into XY, YZ, and XZ planes.

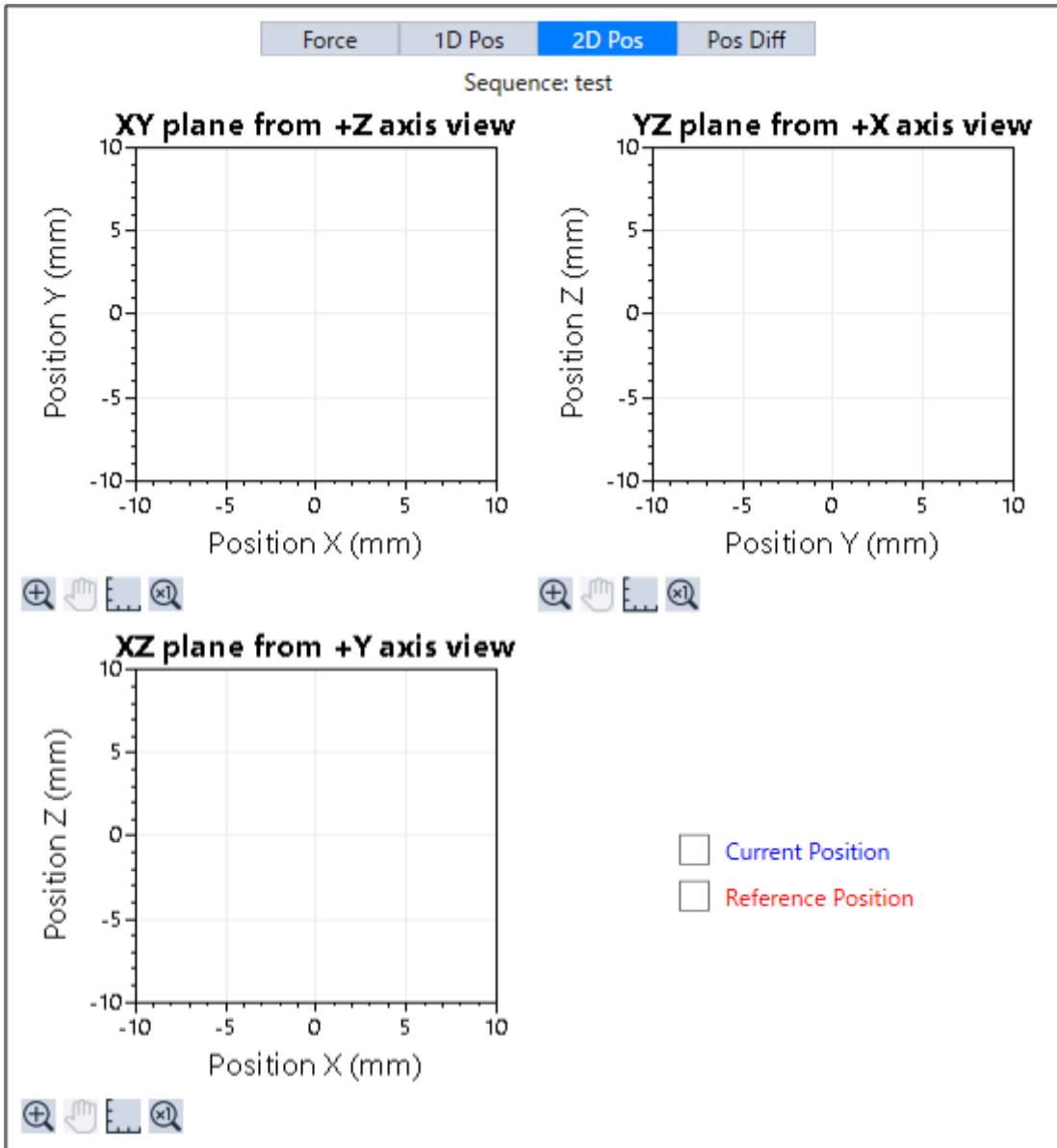

Item	Description
XY plane from +Y axis view graph	Display the command positions (CurPos and RefPos) projected on XY plane in a graph. Vertical axis: Position in Y direction [mm] Horizontal axis: Position in X direction [mm]
YZ plane from +Y axis view graph	Display the command positions (CurPos and RefPos) projected on YZ plane in a graph. Vertical axis: Position in Z direction [mm] Horizontal axis: Position in Y direction [mm]
XZ plane from +Y axis view graph	Display the command positions (CurPos and RefPos) projected on XZ plane in a graph. Vertical axis: Position in Z direction [mm] Horizontal axis: Position in X direction [mm]

Item	Description
Command Position	You can select command positions to be displayed in the right bottom check boxes (Current Position and Reference Position). With a checkmark: Display the selected command positions in a graph. Without a checkmark: The selected command positions are not displayed in a graph. This setting is reflected to all graphs.

- [Pos Diff] tab

Display the difference between the command position (CurPos) including force control and the command position (RefPos) only including position control on the graph by dividing them into each component: X, Y, and Z.

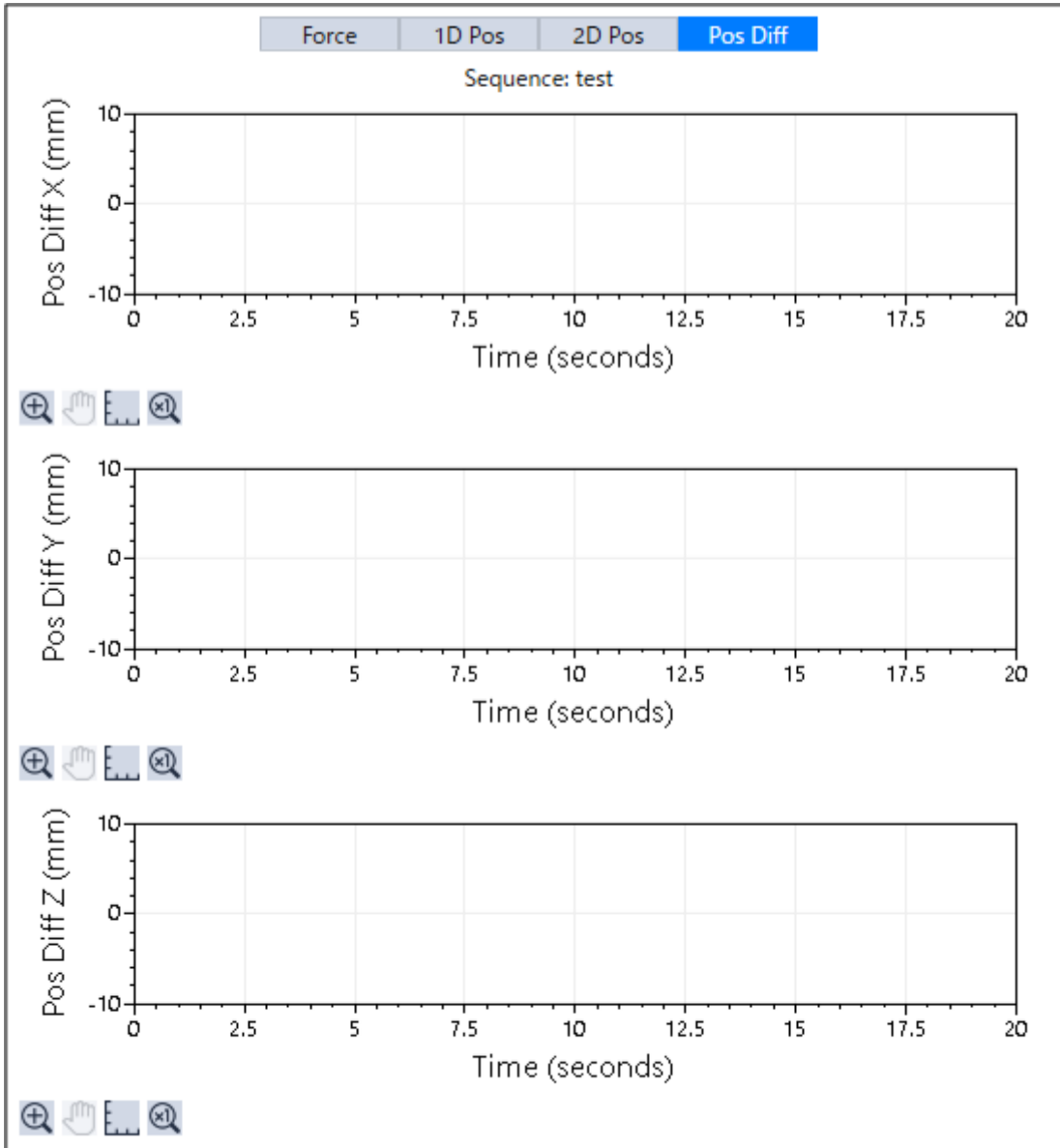

Item	Description
Pos Diff X graph	Display the position difference of the command positions (CurPos and RefPos) in the X direction in a graph. Vertical axis: Positional difference in X direction [mm] Horizontal axis: Time [s]

Item	Description
Pos Diff Y graph	Display the position difference of the command positions (CurPos and RefPos) in the Y direction in a graph. Vertical axis: Positional difference in Y [mm] Horizontal axis: Time [s]
Pos Diff Z graph	Display the position difference of the command positions (CurPos and RefPos) in the Z direction in a graph. Vertical axis: Positional difference in Z [mm] Horizontal axis: Time [s]



• Common functions



There are the following functions common for each graph.

- Enlarged display of graph
- Move an enlarged area
- Change of graph scale

You can use the above functions when the graph is not updating.



Button	Tool tip	Description
	Zoom	To enlarge a graph, select an area where you want to enlarge. Click the button, then move a mouse cursor on the graph. When the cursor moves over the graph, it changes to a cross-hair cursor. Then, an area from the start position to the end position will be enlarged. To return to the original graph, click the button again. Instead of clicking button, you can display enlarged graph by rolling the mouse wheel on the graph. Also while clicking the mouse wheel on the graph and moving left and right, up and down, the graph is enlarged for each axis.
	Pan	Move an enlarged area. Click the button, then move a mouse cursor on the graph. When the cursor moves on the graph, it changes to an arrow cursor. While left-clicking the enlarged area and moving left and right, up and down, the area moves with the mouse motion. Instead of clicking button, while right-clicking the mouse on the graph and moving left and right, up and down, the enlarged area moves with the mouse motion.
	Set scales for axes	Change scales for graph. Click the button to display the [Set Graph Axis Scales] dialog box. You can change the scale for each axis. When set to "Auto", the scale changes automatically depending on the values. When "Auto" is not specified, scale changes to the specified value.

Button	Tool tip	Description
	Restore zoom	Resets the graph enlargement. If you click the  button with the Enlarge Graph button  not pressed, the graph is returned to its default display status (if you have used the right mouse button to move it, or enlarged it by using the mouse wheel). Instead of clicking button, double-click the right mouse button on the graph to show the default size of the graph in the same way as clicking the enlarge graph button.

▪ [New Objects] tab

In New Objects tab, you can add a new force guide object to the force guide sequence.

To add the force guide object to the force guide sequence, select the force guide object and drag it on the flow chart.

Monitor
New Objects
Object Details

To create a new object, select a category, then drag an object to the flow chart.

Category:

- Contact
- Follow
- Probe
- Press
- Align
- Execution
- All Tools

Objects:

 Contact

Contact Object:

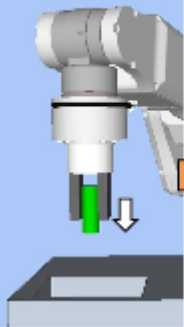
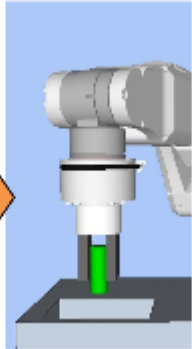
The Contact object moves the robot in the specified direction until it contacts with an object such as a workpiece, and stops the robot when contact occurs. This object is used for detecting the start position for other Force Guide objects or for a grasp position. Even if the workpiece dimension or the grasp position of the workpiece have a margin of error, the next motion or the next Force Guide object can be executed stably since the contact position has been detected.

Item	Description
Category	Items that are classified objects according to functions. You can select the following items. Contact, Follow, Probe, Press, Align, Execution, All Tools

Item	Description	
Objects	Display the force guide object list of items selected in [Category].	
	[Category]	[Objects]
	Contact	Contact
	Follow	Relax, FollowMove
	Probe	PressProbe, ContactProbe
	Press	Press, PressMove
	Align	SurfaceAlign
	Execution	Decision, SPELFunc
	All Tools	All force guide objects
	To add the force guide object to the force guide sequence, select (click) the force guide object that you want to add, and drag it to the flow chart (release the mouse button). When selecting the force guide object from the force guide object list, an image and descriptions of the force guide object are described under the [Category] and the [Objects].	

■ [Object Details] tab

For the force guide object and the force guide sequence which are currently selected, you can check its names, description settings, execution time, and execution result (EndStatus).

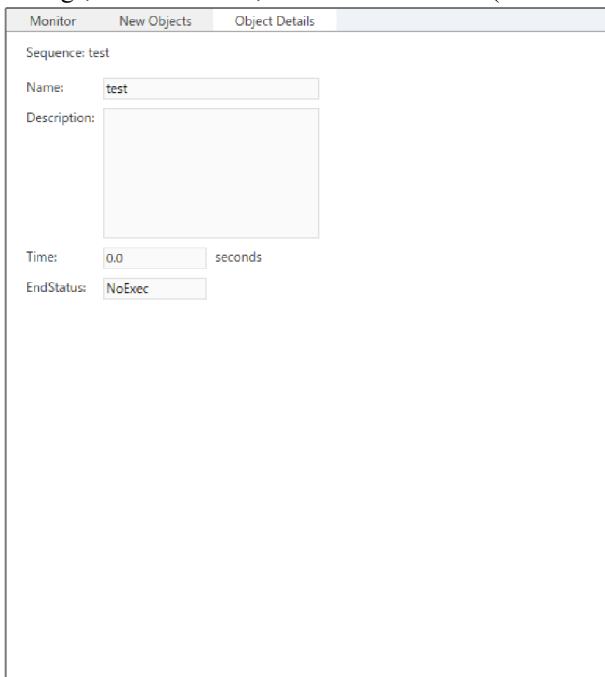

Set or check the selected force guide sequence or force guide object.

Item	Description
Name	Sets up a name. You can enter up to 16 alphanumeric characters.
Description	Sets a description. You can enter up to 255 alphanumeric characters.

Item	Description
Time	Displays an execution time.
EndStatus	Displays an execution result.
MeasuredHeight	Displays a height inspection result. (only for the HeightInspect sequence)

▪ Run panel

In the Run panel, you can execute the force guide sequence and debug. Also, you can move the robot to the specified target position.

There are the [Run] tab and the [Execute Motion] tab on the Run panel.



• [Run] tab

Operate a target force guide sequence.

Reference: Execute a force guide sequence (describe in a later page)

Item	Description
[Run] button	Execute the selected force guide sequence.
[Step] button	Execute the force guide object of the selected force guide sequence from the top.
[Resume] button	Restart the paused force guide sequence.
[Abort] button	Pause the running force guide sequence.
[Low Power] check box	When placing a checkmark in the check box, the robot operates in low power mode. The checkmark is not placed by default.

• [Execute Motion] tab

Specify a motion command and move the robot to a specified target position.

Item	Description
[Run] button	Move the robot to the specified position using the specified motion command.
[Use LJM] check box	With a checkmark: When executing a motion command, the robot automatically changes the orientation to decrease the amount of joint movement and operates. The checkmark is not placed by default.

Flow chart

Flow chart shows the force guide object flows of the currently selected force guide sequence.

- Flow chart order
 - Initial : Force guide sequence which is currently selected.
 - Second or later : Force guide object which is included in the selected force guide sequence.
Force guide objects are in execution order.
- Flow frame color
 - Blue : Normal display.
 - Pink : When the force guide sequence or force guide object is clicked and selected.

▪ Lock marks on flowcharts

A lock mark will appear next to system force guide sequences and system force guide objects on the flowchart. System force guide objects cannot be moved or deleted.

System force guide objects are objects that can only be used in a system force guide sequence. They cannot be added from new objects.

The operations available when right clicking the flowchart are different for system force guide sequences and system force guide objects compared to general force guide sequences and general force guide objects.

See: When right-clicking on the force guide sequence flow:

See: When right-clicking on the object flow:

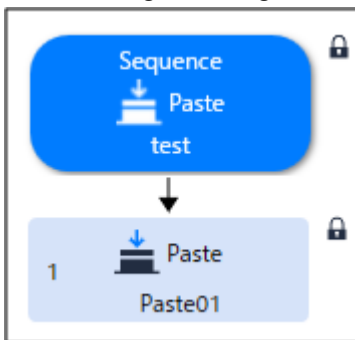

For more information on system force guide sequences, see the following.
Software [Force guidance function](#)

You can call up various operations by right-clicking the flow.

When right-clicking on the force guide sequence flow:

(for general force guide sequences and system force guide sequences)

Item	Description
New sequence	Creates a force guide sequence. To create a force guide sequence, set basic information, select tasks, and select a template according to the sequence wizard. Reference: Create a new force guide sequence
Delete sequence	Deletes a force guide sequence. Delete Force Guide Sequence dialog box, To delete the force guide sequence, select the force guide sequence to delete in the [Delete Force Guide Sequence] dialog box. Reference: Delete a force guide sequence
Run sequence	Executes the selected force guide sequence. Reference: Execute a force guide sequence
Paste	Pastes a copied or cut force guide object.

Item	Description
Create SPEL sequence	Converts a created force guide sequence into a program file of SPEL+. When selecting it, SPEL creation dialog box is displayed. Input the required information on the dialog box and create a SPEL+ program file. Reference: SPEL creation of force guide sequence

When right-clicking on the force guide sequence flow:
(for system force guide sequences)

Item	Description
Sequence wizard	Displays the setting wizard of the system force guide sequence. Reference: Create a new force guide sequence

When right-clicking on the object flow:
(for general force guide sequences and system force guide sequences)

Item	Description
Toggle Breakpoint	Set or release a breakpoint.
	Select when a breakpoint is not set: You can set a breakpoint. When setting is done, an icon is displayed on the upper right of the object flow.
	Select when a breakpoint is set: Release a breakpoint. When releasing it, the icon displayed on the upper right of the object flow is cleared
	If you execute the force guide sequence when setting the breakpoint, the object pauses at the object flow which the breakpoint is set.
Paste	Pastes a copied or cut force guide object.

When right-clicking on the object flow:
(for general force guide sequences)

Item	Description
Copy	Copy the selected force guide object.
Cut	Cut the selected force guide object.
Delete	Delete the selected force guide object. When you select it, a confirmation message is displayed. [Yes] button: Force guide object is deleted. [No] button: Force guide object is not deleted.

You can check the execution status and the execution results of the sequences in sequence/object flow on the flow chart.

Item	Condition	Description
Color of frame	Blue	Indicate normal condition.
	Purple	Indicate the selected conditions.
	Black	Indicate the pause condition.
	Green	Indicate the in-execution condition.

Item	Condition	Description
Color within a frame	White	Indicate normal condition.
	Yellow	Indicate the pause condition.
	Light blue	Indicate the in-execution condition.
Upper left icons within a frame	Image ✓	Indicate that the execution of the force guide sequence or force guide object is succeeded.
	Image ×	Indicate that the execution of the force guide sequence or force guide object is failed.

Sequence tree

Tree shows all sequences.

Sequence node and object node in the sequence tree can operate the same operation flow as the flow chart.

Property window

In the property window, you can change each property value of the force guide object or force guide sequence.

Display the property window by the following ways: Select a sequence flow or an object flow on the flow chart. Select a sequence node or an object node on the sequence tree

Sequence: test	
Property	Value
Name	test
Index	1
Description	
SequenceVersion	V751 ▼
RobotNumber	1 ▼
RobotType	Six Axis
AutoStepID	True ▼
ResetSensor	True ▼

For details of each property, refer to the following section. Software 4. Force Guidance Function

Result window

In the result window, you can check the execution results of the force guide sequence or force guide object.

Display the result window by the following ways: Select a sequence flow or an object flow on the flow chart. Select a sequence node or an object node on the sequence tree

Result	Value
EndStatus	
EndStatusData	
Time	
LastExecObject	
> EndForces	
> PeakForces	

For details of each result, refer to the following section. Software 4. Force Guidance Function

Description window

The description window displays the name and simple descriptions for selected properties or results on the property window or the result window.

EndStatus

The status of a sequence or object at the end of execution.

[Jog] tab

[Jog] tab is displayed when selecting the [Jog] tab on the right side of the sequence tree.

[Jog] tab can be a fly-out panel, which can be placed wherever you like.

When performing Jog motion, you need to turn ON the robot motor. Turn ON the motor by [Robot] tab.

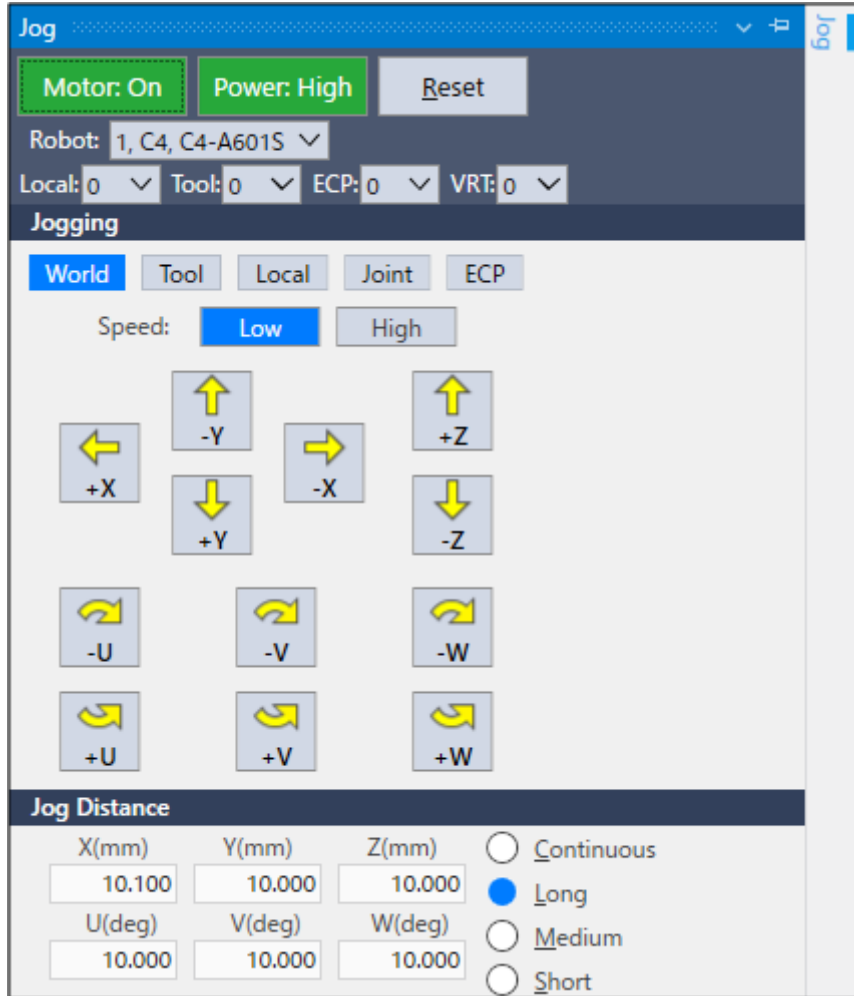

Item	Description
Motor: On/Off	Set the robot motor turn on/off.
Power: High/Low	Set the robot motor power High/Low.
Reset	Reset the servo system and the Emergency Stop state of the robot.
Robot	Select the robot type.
Mode	Set the jog mode. (World, Tool, Local, Joint, ECP)
Speed	Set the jog speed. (Low speed, high speed)
[Jog Distance] group	Set the distance of jog motion. (Continuance, large, medium, small) When selecting "large", "medium", or "small", you can change the distance by entering a value in the text boxes.
Jog button	To operate a robot in jog mode, click the jog button after setting the jog mode, jog speed, and a distance of jog motion.
	Select the [Continuous] button on [Jog Distance]. The robot will continue jog motion until the jog button is released.

Item	Description
	Select a button other than [Continuous] on [Jog Distance]. The robot will operate the jog distance as one step. If you keep clicking the jog button, the robot keeps operating the jog motion.

Create a new force guide sequence

■ Overview

Create a force guide sequence by using sequence wizard. This sequence wizard can be displayed by doing the following.

Click the [New sequence ] button on the Force Guide tool bar.

Right-click the sequence flow on the flow chart or the sequence node on the sequence tree to select [New sequence].

When the sequence wizard is displayed, select the sequence according to each window.

■ Sequence Wizard: Create a general force guide sequence

• Step 1: General

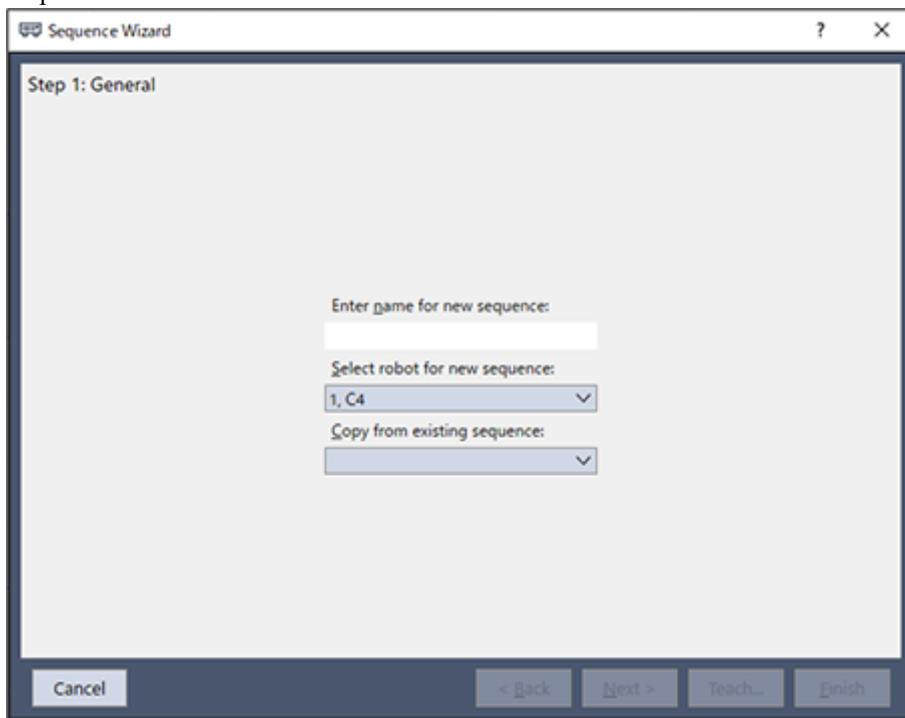

Item	Description
General	Enter name for new sequence: Enter a force guide sequence name. (up to 16 characters in alphanumeric characters.)
	Select the robot that will use the new sequence. Select a robot that uses a new force guide sequence from the list of currently registered robots.
	Copy from existing sequence: To create a force guide sequence by copying an existing force guide sequence, select the force guide sequence to be copied from the list. When you do not wish to copy a sequence, select the blank space in the list.
[Cancel] button	Cancels the creation of a new sequence . Click it to end a sequence wizard.

Item	Description
[Back] button	Returns to the previous Step. You cannot click the button since the current step is Step 1.
[Next] button	Proceeds to the next Step. In [Copy from existing sequence] When you select "Force guide sequence" You cannot click this button. When you select a blank space: You can click the button.
[Finish] button	Completes the creation of the new force guide sequence. Creates a new force guide sequence with the entered information.

- Step 2: Select sequence type

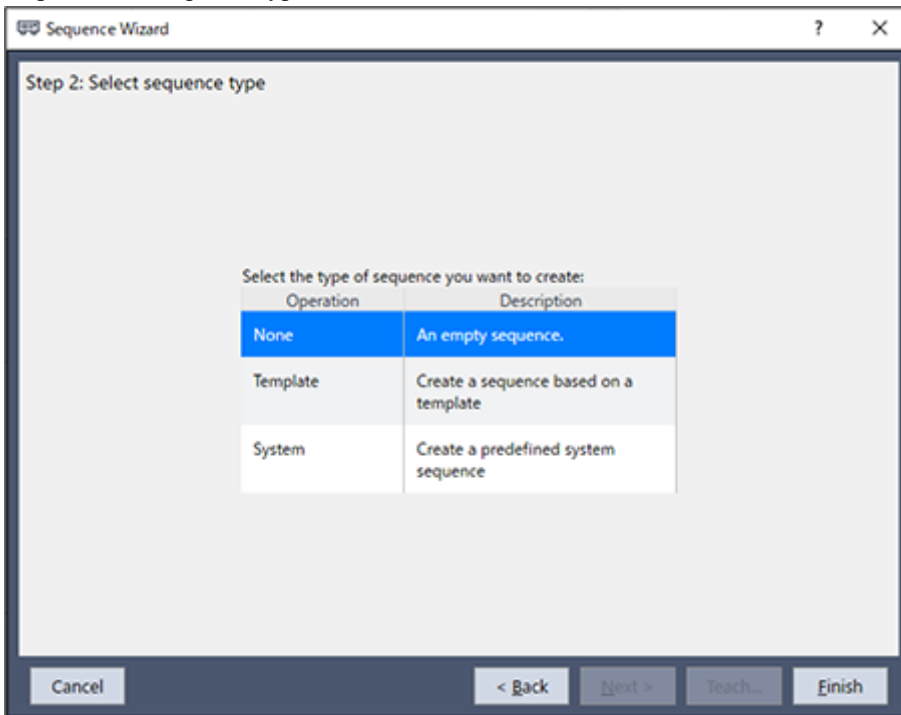

Item	Description
Select sequence type	When you use a template as the force guide sequence, select [Template]. When you do not use a template, select [Empty].
[Cancel] button	Cancels the creation of a new force guide sequence. Click it to end a sequence wizard.
[Back] button	Returns to the previous Step.
[Next] button	Proceeds to the next Step. When you select [Select type of force guide operation you want to do]-[None]: You cannot click this button. When you select other than [Select type of force guide operation you want to do]-[None]: You can click the button.

Item	Description
[Finish] button	Cancels the creation of a new sequence. When you select [Select type of force guide operation you want to do]-[None]: You can click the button. When you select other than [Select type of force guide operation you want to do]-[None]: You cannot click this button.

- Step 3: Select type of force guidance operation you want to do

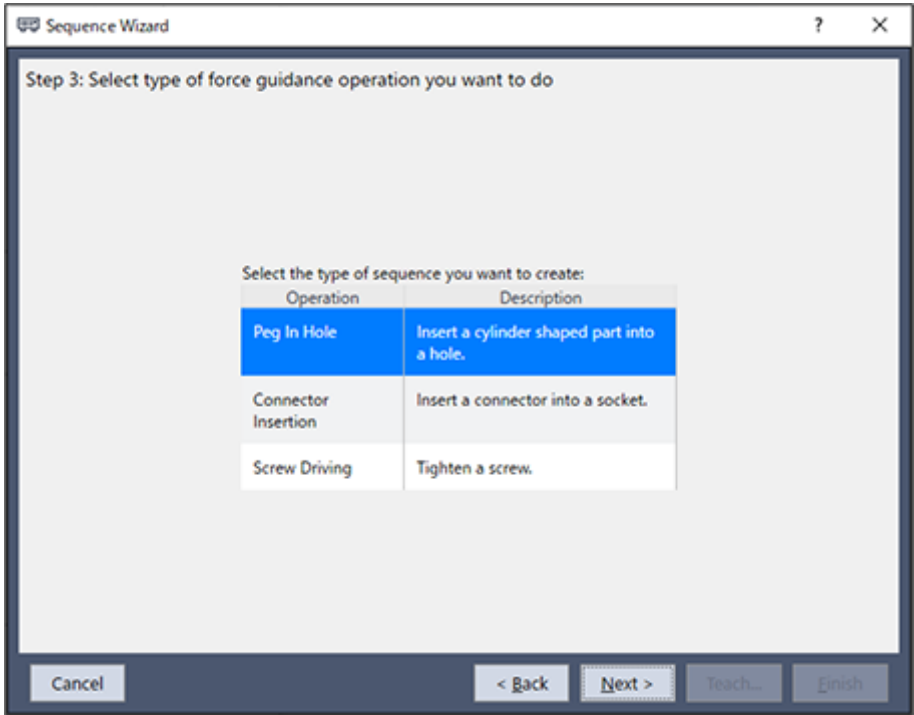

Item	Description
Select type of force guidance operation you want to do	Select an operation to do from the followings. Peg In Hole Connector Insertion ScrewTighten
[Cancel] button	Cancels the creation of a new force guide sequence. Click it to end a sequence wizard.
[Back] button	Returns to the previous Step.
[Next] button	Proceeds to the next Step.
[Finish] button	Cancels the creation of a new sequence. You cannot click this button in the current step.

- Step 4: Select the sequence template for the selected operation

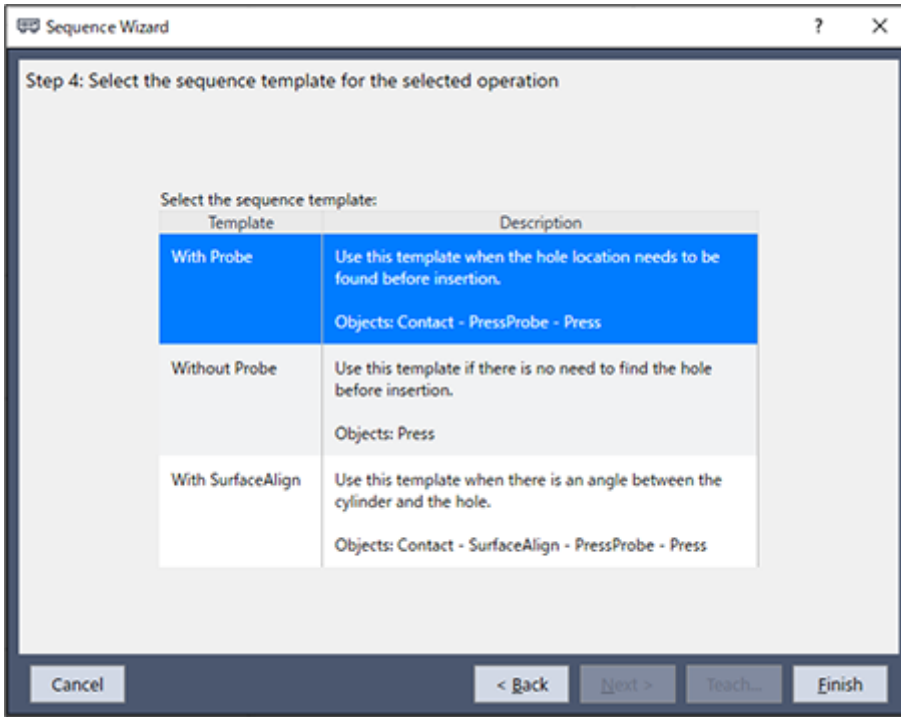

(The above dialog box is an image when selecting [Peg In Hole] in the Step 2.)

Item	Description
Select the sequence template for the selected operation	Select a template from the followings. When selecting [Peg In Hole]: With Probe, Without probe, With SurfaceAlign. When selecting [Connector Insertion]: With Probe, Without probe When selecting [Screw Driving]: Standard
[Cancel] button	Cancels the creation of a new force guide sequence. Click it to end a sequence wizard.
[Back] button	Returns to the previous Step.
[Next] button	Proceeds to the next Step. You cannot click the button since the current step is Step 4.
[Finish] button	Completes the creation of the new force guide sequence. Creates a new force guide sequence with the entered information.

- Sequence Wizard: Create a new system force guide sequence

- Step 1: General

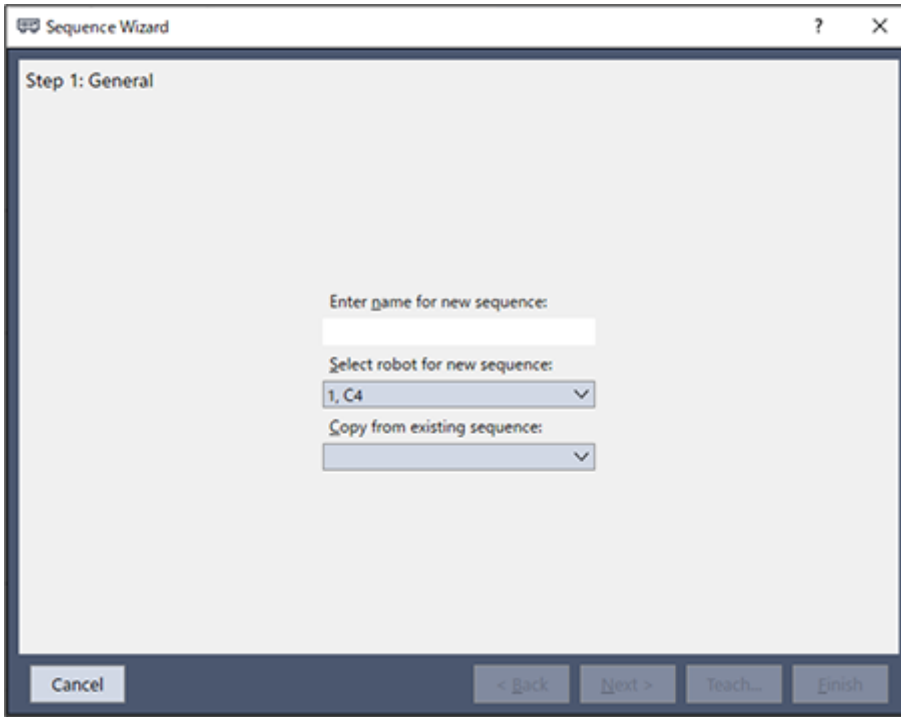

Item	Description
General	Enter name for new sequence: Enter a force guide sequence name. (up to 16 characters in alphanumeric characters.)
	Select the robot that will use the new sequence. Select a robot that uses a new force guide sequence from the list of currently registered robots.
	Copy from existing sequence: To create a force guide sequence by copying an existing force guide sequence, select the force guide sequence to be copied from the list. When you do not wish to copy a sequence, select the blank space in the list.
[Cancel] button	Cancels the creation of a new sequence . Click it to end a sequence wizard.
[Back] button	Returns to the previous Step. You cannot click the button since the current step is Step 1.
[Next] button	Proceeds to the next Step. In [Copy from existing sequence] When you select "Force guide sequence" You cannot click this button. When you select a blank space: You can click the button.
[Finish] button	Completes the creation of the new force guide sequence. Creates a new force guide sequence with the entered information.

- Step 2: Select sequence type

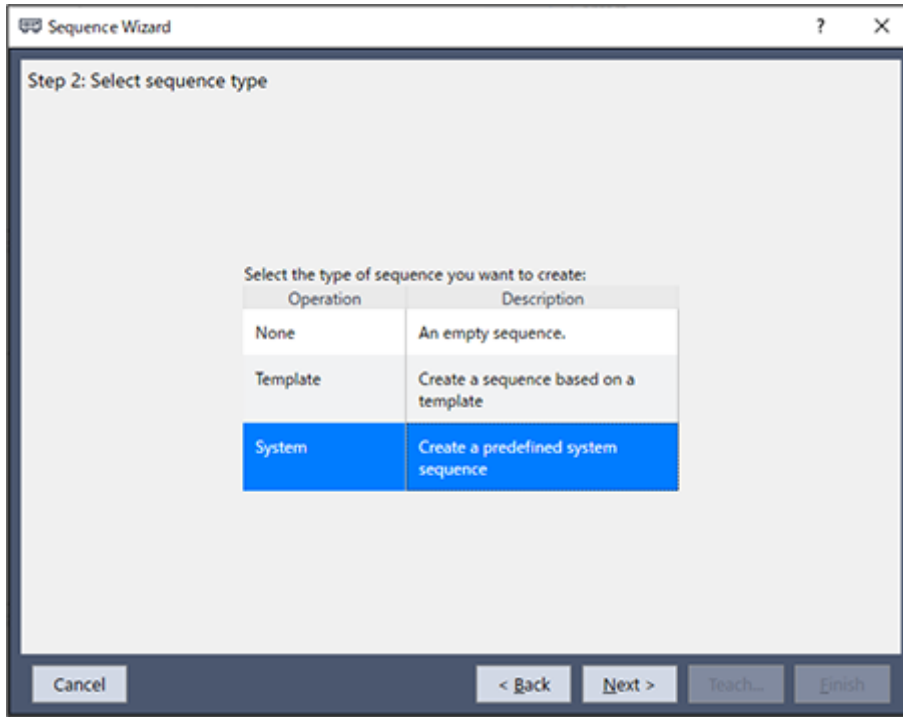

Item	Description
Select sequence type	To create a system force guide sequence, select [System].
[Cancel] button	Cancels the creation of a new force guide sequence. Click it to end a sequence wizard.
[Back] button	Returns to the previous Step.
[Next] button	Proceeds to the next Step. When you select [Select type of force guide operation you want to do]-[None]: You cannot click this button. When you select other than [Select type of force guide operation you want to do]-[None]: You can click the button.
[Finish] button	Cancels the creation of a new sequence. When you select [Select type of force guide operation you want to do]-[None]: You can click the button. When you select other than [Select type of force guide operation you want to do]-[None]: You cannot click this button.

- Step 3: Select system sequence

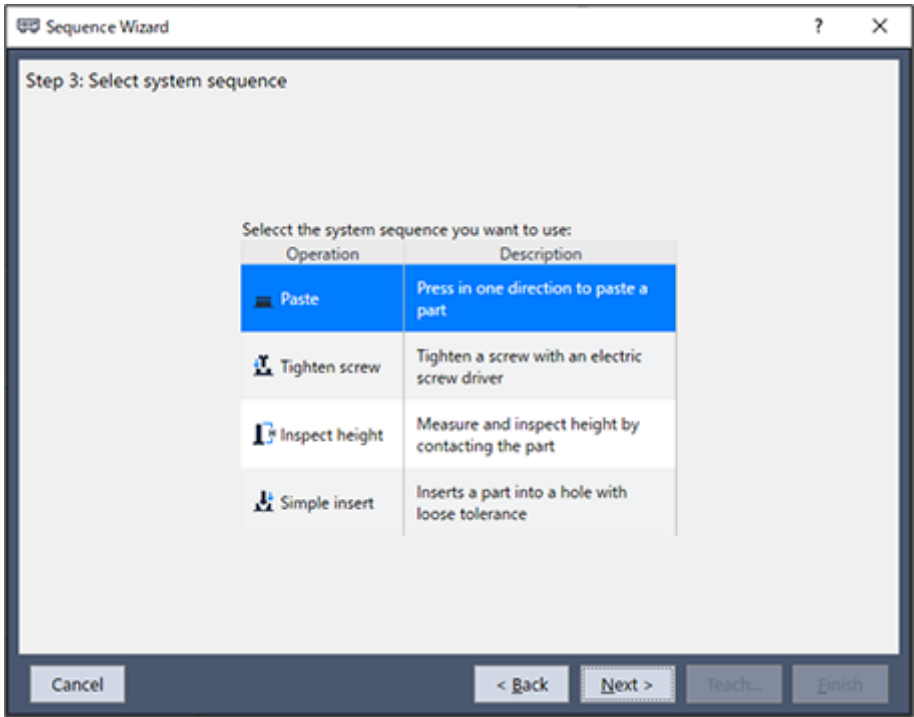

Item	Description
Select system sequence	Select the type of system force guidance operation you want to create from the following: Paste ScrewTighten HeightInspect Insert
[Cancel] button	Cancels the creation of a new force guide sequence. Click it to end a sequence wizard.
[Back] button	Returns to the previous Step.
[Next] button	Use this to advance to the next step in the system force guide sequence wizard. For more information on the system force guide sequence wizard, see the following. Software Force guidance function
[Finish] button	Cancels the creation of a new sequence. You cannot click this button in the current step.

Delete Force Guide Sequence

▪ Overview

1. Display the [Delete Force Guide Sequence] dialog box in one of the following ways:

Click the [Delete sequence ] button on the Force Guide tool bar.

Right-click the sequence flow on the flow chart or the sequence node on the sequence tree to select [Delete sequence].

2. Select a sequence that you want to delete by using a mouse or an arrow key.

3. When the force guide sequence name that you want to delete is highlighted, click the [Delete] button.

4. A confirmation message is displayed.

Click the [Yes] button to delete a sequence. If you want to cancel a deletion, click the [No] button.

- [Delete Force Guide Sequence] dialog box

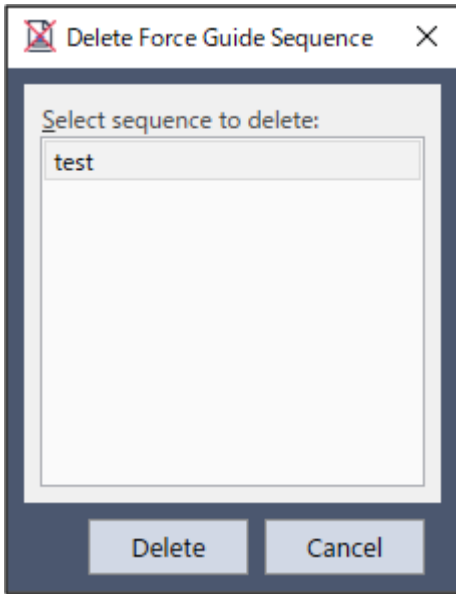

Item	Description
Selection list	Select a force guide sequence to be deleted.
[Delete] button	Delete a highlighted force guide sequence. When you click the button, a confirmation message is displayed. [Yes] button: Delete a force guide sequence. [No] button: Cancel a deletion.
[Cancel] button	Cancel a deletion of a force guide sequence. End the [Delete Force Guide Sequence] dialog box.

Execute Force Guide Sequence

- Overview
 1. Execute a force guide sequence in one of the following ways:
Click the [Run] button.
To select [Run Sequence], right-click the sequence flow on the flow chart or the sequence node on the sequence tree.
 2. A confirmation message appears for executing the force guide sequence. Click the [Yes] button to execute the sequence. If you want to cancel execution, click the [No] button.

Execution result of the force guide sequence execution:
You can check the results on flow chart or result window.

Success or failure of execution result:
You can check it on the flow chart. For more detailed information, check the result window.

- Breakpoint setting
Breakpoint is a function to pause the force guide sequence execution when the force guide object starts by setting to a force guide object.

Set or release a breakpoint by the following way:

- Right-click a target force guide object on the object flow of the flow chart or the object node on the sequence tree, and select the [Toggle Breakpoint].
- After selecting the target force guide object, click the [F9] key.

- Step

"Step" is a function to execute the force guide object step-by-step.

For example, when executing the force guide sequence with step execution, the program pauses at the first force guide object. Every time you click the [Step] button, the program repeats the operation to execute the paused force guide object and pause at the next force guide object.

To execute a force guide sequence in step execution, click the [Run] panel- the [Step] button.

You can click the [Step] button when the force guide sequence is not executed or the program is paused during the force guide sequence execution. You can execute the next force guide object by clicking the button.

- Resume

"Resume" is a function to restart the execution from where it is paused during the force guide sequence execution.

To execute a force guide sequence in continuous execution, click the [Run] panel- the [Resume] button.

You can click the [Resume] button when the sequence is paused during the force guide sequence execution. You can restart the program from where it paused.

- Abort

"Abort" is a function to stop the running force guide sequence.

To stop the force guide sequence, click the [Run] panel-the [Abort] button.

You can click the [Abort] button when the force guide sequence is running or the program is paused. Click the button to stop the running force guide sequence. You cannot restart the stopped force guide sequence.

Create SPEL Program from Force Guide Sequence

- Overview

Use the [Create SPEL Sequence] dialog box to create SPEL programs by the force guide sequences.

1. Right-click the sequence flow of the flowchart or the sequence node of the sequence tree, then select [Create SPEL sequence].
2. The [Create SPEL Sequence] dialog box is displayed.
Select the sequence and enter the program file name.
3. Click the [Create] button. The SPEL program is created.

▪ [Create SPEL Sequence] dialog box

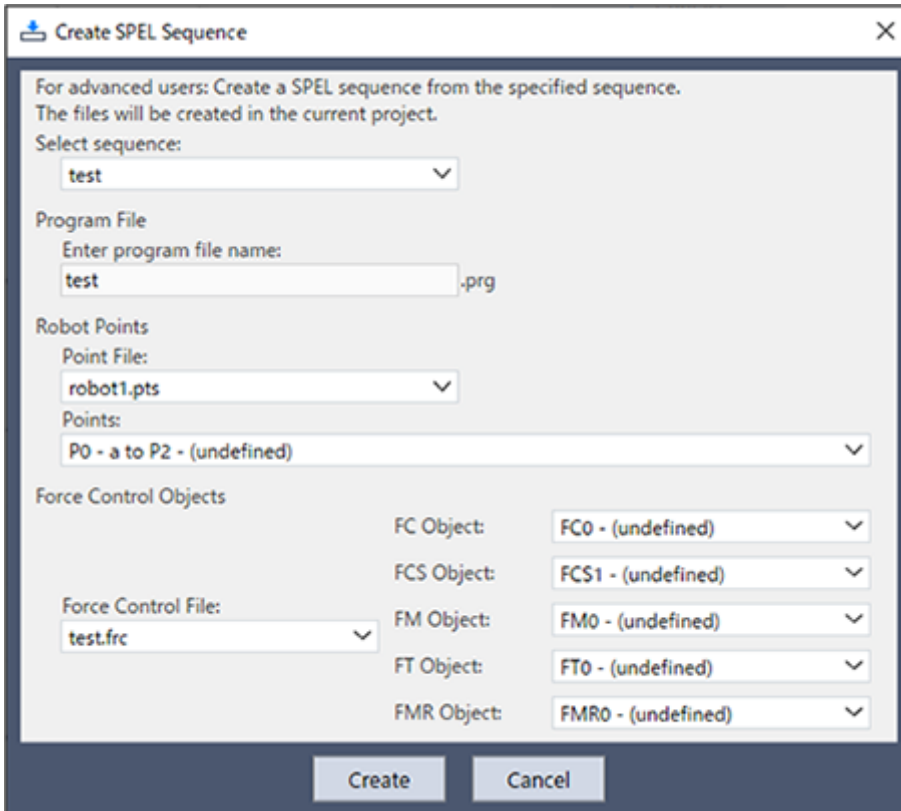

Item	Description
Select sequence	Select the force guide sequences which create SPEL program.
Program file name Enter	Enter program file name of SPEL to be created. Default: Selected force guide sequence name.prg
Point File	Select a point file to be used for the created SPEL program. The created SPEL program loads the file specified by LoadPoints statement. If loading the file is not required, comment out the statement.
Point	Select a point range to be used for the created SPEL program. The created SPEL program overwrites the selected point range everytime the program is executed. Specify the undefined point range.
Force File	Select the force file to be used for the created SPEL program. If there are no force files are existed, create a force file with file name ("robot"+ robot number) such as "robot1.frc". The created SPEL program loads the file specified by Fload statement. If loading the file is not required, comment out the statement.
FC Object FCS Object FM Object FT Object FMR Object	Select force guide object used in the created SPEL program. The created SPEL program overwrites the selected force object every time the program is executed. Specify the undefined point.

<p>[Create] button</p>	<p>Create SPEL program. Create a program based on the entered information and add it to the project. If the existing program file name is already entered as a program name, the message to confirm overwriting is displayed. [Yes] button : Overwrite the program file. [No] button : Return to the dialog box without creating the program.</p>
<p>[Cancel] button</p>	<p>Cancel SPEL program creation. Exit the [Create SPEL Sequence] dialog box.</p>

4.3.6 Force Editor

Open a force file from the object tree of Project in [Project Explorer] to display the [Force Editor] window. The display can be selected using the tabs, and each object and property can be edited.

When values are changed, a message confirming whether to save the changes appears when closing the window.

For the details, refer to the following section.

Software [\[Robot Manager\] \(Tools Menu\)](#)

- [Tools]-[Robot Manager]-[Force] Panel

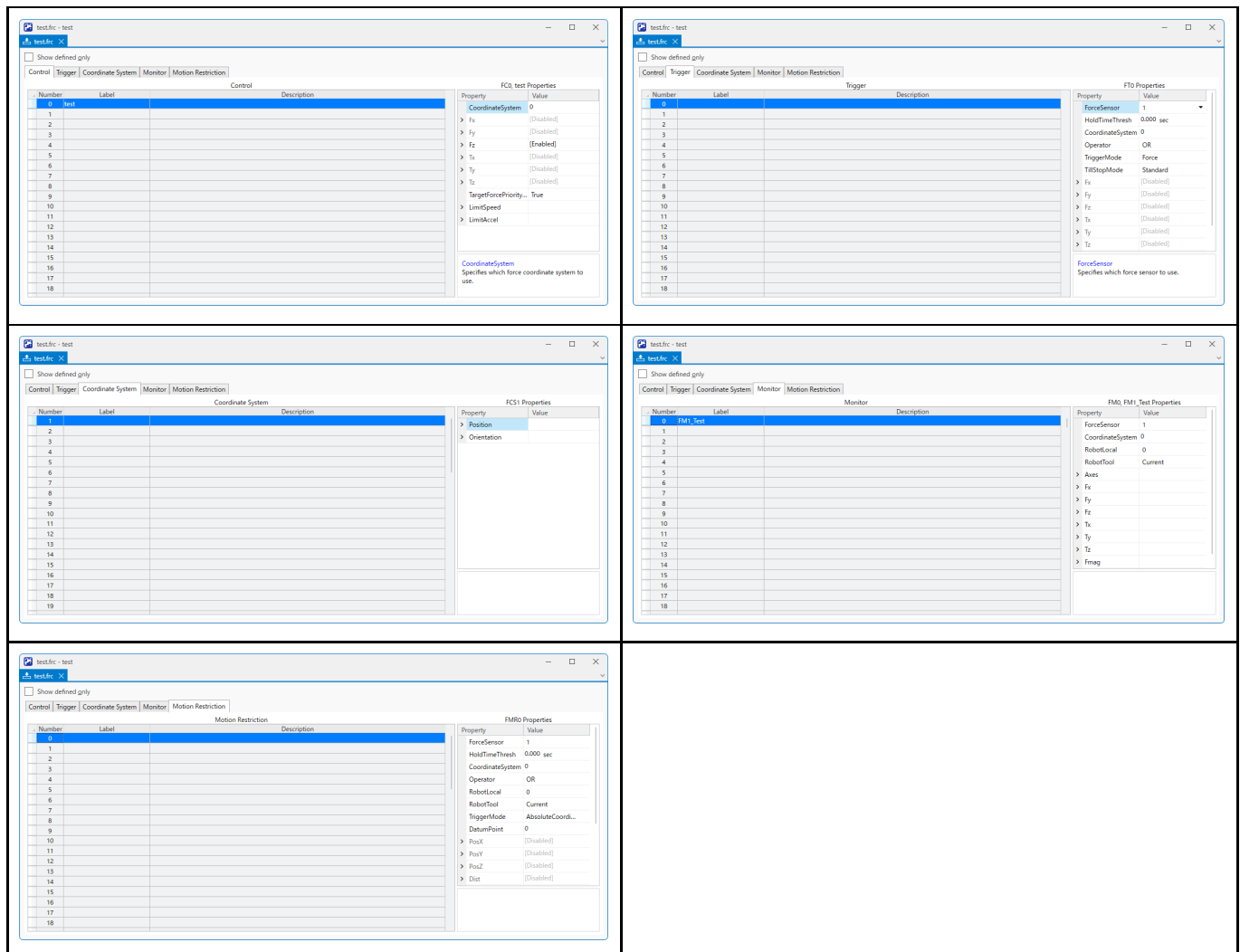

4.3.7 [System Configuration] menu

Epson RC+ 8.0 Menu- [System Configuration] allows you to change the development environment setting.

4.3.7.1 Force Sensor

Select [System Configuration]-[Controller]- [Force Sensor]-[Sensor*] to open the settings.

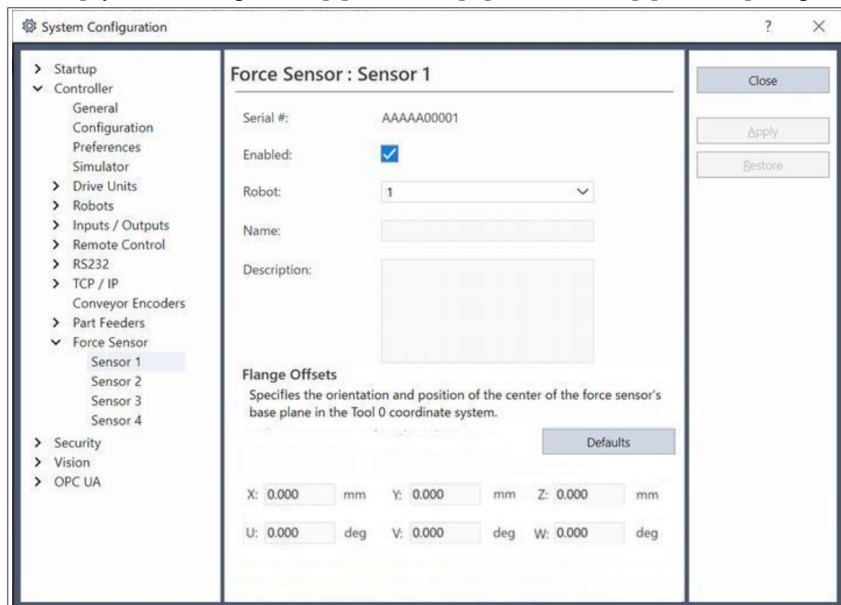

Item	Description
Enabled	Set the sensor to use.
Robot	Set the robot to use.
Close	Close the [System Configuration] dialog.
Apply	Apply the input value.
Restore	Restore the value before applying.
Flange Offsets	Set the robot object, and FlangeOffset property.
Defaults	Set the default value to the flange offset.

4.3.8 Sequence Reconcile Function

This section describes the sequence reconcile function.

The sequence reconcile function is used to upgrade and limit functions according to the user's Epson RC+ 8.0 and firmware version.

This ensures compatibility for the following:

- Force Guide Sequence
- Force File

4.3.8.1 Sequence Reconcile Function for Force Guide Sequences

Use this function to upgrade or limit force guide sequence functions.

This function recognizes the Epson RC+ 8.0, firmware, and force guide file version in use, and displays the force guide sequence reconcile wizard only when necessary. When this window appears, perform the necessary compatibility adjustments as instructed on the screen.

When force guide sequence updates are available

The force guide sequence shown can be updated. To apply an update, select the item to upgrade, and then click the OK button. Note that operation cycle times may change when applying updates.

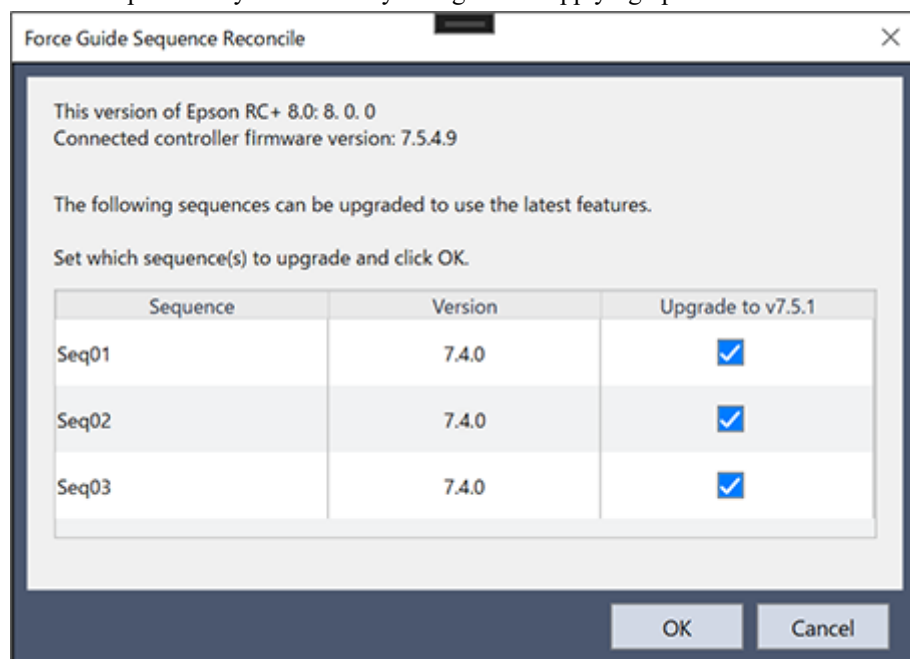

Item	Description
This version of Epson RC+ 8.0	The Epson RC+ 8.0 version number.
Connected controller firmware version	The firmware version of the controller connected to Epson RC+ 8.0.
Sequence	The names of sequences that can be updated.
Version	The current sequence version.
Upgrade to vXXX*1	Select whether to upgrade the sequence.
[OK] button	This ends the sequence reconcile function. Compatibility adjustments will be applied according to the information entered.
[Cancel] button	This cancels the sequence reconcile function. Click the button to end the force guide sequence reconcile wizard.

*1 XXX refers to the latest sequence version available to update to.

When force guide sequences need to be downgraded or deleted

The sequences shown must be downgraded or deleted. To downgrade or delete the sequence, click the [OK] button.

Note that operation cycle times may change when applying downgrades.
Once deleted, deleted sequences cannot be restored.

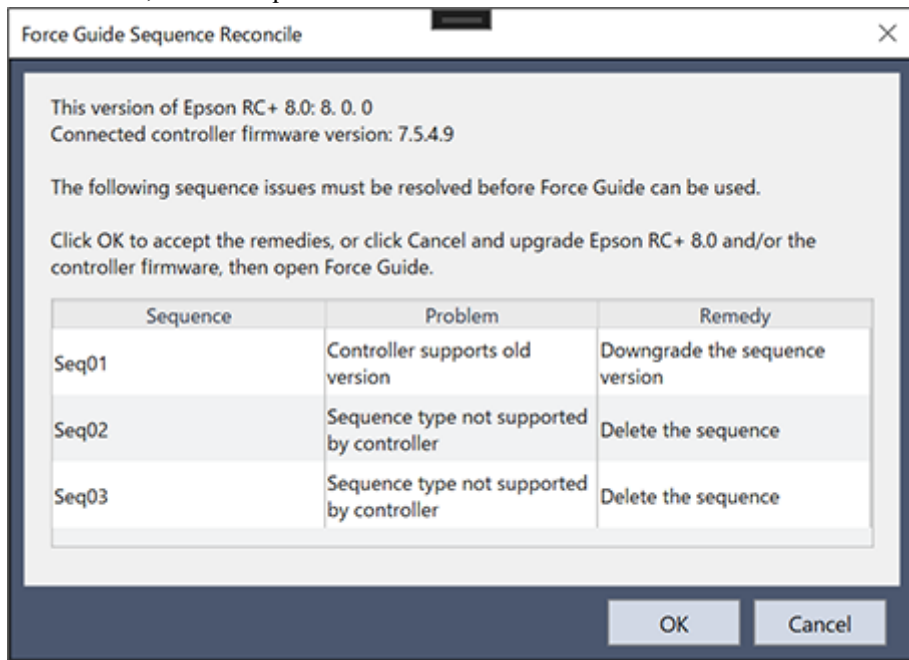

Item	Description
This version of Epson RC+ 8.0	The Epson RC+ 8.0 version number.
Connected controller firmware version	The firmware version of the controller connected to Epson RC+ 8.0.
Sequence	The names of sequences that can be updated.
Problem	Issues requiring sequences to be downgraded or deleted.
Remedy	The remedy applied when reconciling compatibility.
[OK] button	This ends the sequence reconcile function. Compatibility adjustments will be applied according to the information entered.
[Cancel] button	This cancels the sequence reconcile function. Click the button to end the force guide sequence reconcile wizard.

4.3.8.2 Sequence Reconcile Function for Force Files

You can limit force file functions.

This function recognizes the Epson RC+ 8.0, firmware, and force file version in use, and displays this dialog window only when necessary.

To downgrade, click the [Yes] button.

Note that operation cycle times may change when applying downgrades.

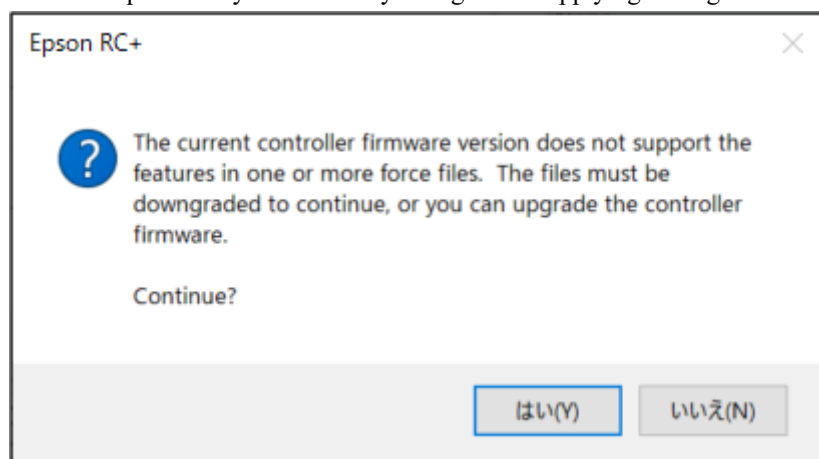

4.4 Force guidance function

The following describes the force guidance function.

Force guidance function creates an operation using force control function, force trigger function, and force monitor function without programming by SPEL+ language.

Call up an operation (force guide sequence) created by force guidance function from SPEL+ language and execute it. It allows you to execute the force function at any timing in the created SPEL+ program.

4.4.1 Steps and Basic Concepts for using the Force Guidance Function

The following describes the basic concepts to use the force guidance function according to the steps. More specific examples are described in Tutorial. This chapter describes general steps and concepts.

For more specific examples, refer to the following section. Software [Tutorial](#)

Steps to use the force guidance function are as follows: This section describes about the following items.

- [Using the SPEL+ Language to Create Motions Prior to Starting Force Control Function](#)
- [Set a force guide sequence](#)
- [Set force guide object\(s\)](#)
- [Adjust While Executing Test](#)
- [Execute a force guide sequence using the SPEL+ language](#)

4.4.1.1 Using the SPEL+ Language to Create Motions Prior to Starting Force Control Function

Force guidance function creates an operation using force control function. Therefore, a motion without using force control function such as movement to a start position is created by using SPEL+ language.

Here is a simple example:

```
Function main
  Motor On
  Go P1      'Go to the start position
End
```

Generally, the force control function is operated in low speed compared to a normal robot motion. To shorten a cycle time, we recommend operating minimum necessary tasks by the force guidance function. Therefore, make sure to set a start position where the grasped workpiece or tool does not contact with a workpiece to be contacted. Also, set a start position as close as possible to the workpiece to be contacted. When setting a start position, consider workpiece variations. Avoid setting a start position where cannot be contacted by a certain workpiece but the other workpiece can.

In a case of Peg In Hole task, when all workpieces including variations are within a taper range of a hole, cycle time can be shortened. This is because a process to probe a hole can be omitted. As described, cycle time will be shortened by omitting a process such as a hole/a step probing during an operation.

As a summary of the above descriptions, conditions of an ideal start position are as follows: When operating Peg In Hole task and the robot grasps a cylinder, workpiece is as close as possible to the other workpiece with a hole. Position of the workpiece does not contact with the workpiece with a hole. Workpiece is within a taper range of the hole

Key Point

The force control function cannot be executed near the singular point of the robot. Make sure to set a start position with avoiding near the singular point even during the operation of tasks created by the force guidance.

4.4.1.2 Set a force guide sequence

In the force guidance function, operations to be executed are shown as a "group" of force guide sequences. It is like a container that the required force guide objects are aligned in a specific order to execute the whole or part of the specific operation. Force guide sequences consist of general force guide sequences created by adding any general force guide objects, and system force guide sequences for specific operations.

The following table shows a list of system force guide sequences.

Name	Description
Paste	Aligns the surface of the workpiece being gripped with the surface of the target object, and presses in the direction specified.
ScrewTighten	Tightens screws using an electric screwdriver. Once tightened, you can also instruct the robot to loosen the screw and retighten.
HeightInspect	Stops the robot upon contact with a target object when moving in a specified direction, and measures and inspects the height of the object.
Insert	Inserts the workpiece. This can also confirm that an inserted workpiece cannot be removed by applying a force in the direction opposite to the direction of insertion after the insertion of a connector, etc.

Force guide sequence has properties and results.

- **Properties**
Value for force guide sequence. Some properties affect to the whole force guide sequence, and other properties are processing settings when executing the force guide sequence.
- **Result**
Value showing the result of the force guide sequence.

Set a force guide sequence by the following steps.

- Step 2-1. Create a force guide sequence
- Step 2-2. Set the properties of the force guide sequence

However, Epson Force Sensor has a characteristic to accumulate errors due to the drift. Therefore, the force control function must be executed within 10 minutes after resetting the Force Sensor. If operating the operation for 10 minutes or more, divide the force guide sequences into two sequences and review the operation to restart the second force guide sequence after changing it to a non-contact state.

Also, the force guide sequence needs adjustment depending on the usage environment (robot, hand, workpiece, or position). When operating the same operation in different position, a single force guide sequence may only operate the either operation. In that case, divide the force guide sequence into two sequences and adjust for each.

4.4.1.2.1 Step 2-1. Create a force guide sequence

Create a force guide sequence on the force guide window. To create a force guide sequence, create an empty force guide sequence first. Then, align any force guide objects. Or, specify a template when creating the force guide sequence and automatically align the required force guide objects for an operation. The system force guide sequence is set by the sequence wizard, and the force guide object is automatically placed.

For more details on the creation steps, refer to the following section.

Software [\[Force Guidance\] \(Tools Menu\)](#)

4.4.1.2.2 Step 2-2. Set the properties of the force guide sequence

Set properties of force guide sequence. You need to set properties depending on an operation. You can set the properties of the system force guide sequence in the sequence wizard.

For more details on each property, refer to the following section.

- [General Sequence](#)
- [Paste Sequence](#)
- [ScrewTighten Sequence](#)
- [HeightInspect Sequence](#)
- [Insert Sequence](#)

For more details on the setting steps of the properties, refer to the following section.

Software [\[Force Guidance\] \(Tools Menu\)](#)

4.4.1.3 Set force guide object(s)

Force guidance function indicates the specific processes such as a specific motion including the force control function or conditional branching as a force guide object. Align processes (force guide objects) in a container (force guide sequence) to realize a specific operation.

In the force guidance function, you can create a force guide sequence by combining the ten types of general force guide objects and the six types of the system force guide objects. However, system force guide objects can only be used in system sequences. Operation using the force control function can be divided into the following five basic motions:

"Contact", "Follow", "Align", "Probe", "Press"

Force guide object can be divided into seven categories: the above five basic motions, "Run" which is a processing other than the force control function, and "System" aligned in the system force guide sequence automatically. In addition, some force guide objects run more than two basic motions simultaneously.

- **Contact**
Motion to move the robot from a non-contact state until it touches an object, then stops in the contact position. Use this motion to detect a position of workpiece. Contact object performs the contact motion.
- **Follow**
Motion to repeat the applied force and torque to adjust a position. Use this motion to move the robot to a position where the applied force will be "0". Relax object and FollowMove object perform the follow motion.
- **Align**
Motion to adjust the position or orientation of a workpiece that will be grasped, pressed against a target object, and aligned with its shape or orientation. Use this motion to align a workpiece to be grasped with an object. SurfaceAlign object performs the align motion.
- **Probe**
Motion to detect a hole or a step on an object. Use this motion to detect a hole or a step. The PressProbe object and ContactProbe object perform the probe motion.
- **Press**
Motion to keep applying a certain amount of force and torque to an object. Use this motion to apply a certain amount of force and torque to an object. The Press object and PressMove object perform the press motion. Also, in the operation using

the force control function, especially the press motion often presses and follows to different directions simultaneously. Insertion operation of workpiece, for instance, presses to insertion direction and follow two directions perpendicular to the insertion direction. Therefore, the Press object and PressMove object can perform the press and follow motions in different axes at the same time.

■ Execution

Processing other than the force control. The following objects perform it:

- Decision Object
Force guide object which performs conditional branching.
- SPELFunc Object
Force guide object which executes functions of SPEL+ programs.

■ System

An object is placed automatically when the system force guide sequence is created. This applies to the following objects.

- Paste Object
An object that presses in the specified direction while aligning the surface of the workpiece being gripped with the surface of the target object.
- ScrewTighten Object
An object used to tighten screws using an electric screwdriver.
- ScrewRetighten Object
An object used to first loosen, then retighten a screw tightened with an electric screwdriver.
- HeightInspect Object
An object used to stop the robot upon contact with a target object when moving in a specified direction, and to measure and inspect the height of the object it has come into contact with.
- Insert Object
An object used to insert a workpiece.
- TensileTest Object
An object used to confirm that an inserted workpiece (a connector, etc) cannot be removed by applying a force in the direction of or opposite to the direction of insertion.

The following is a list of categories and force guide objects.
For more details on each object, refer to the following section.

General force guide object

Paste Object

ScrewTighten Object

ScrewRetighten Object

HeightInspect Object

Insert Object

TensileTest Object

Category	Object name	Description
Contact	Contact	Move the robot to the specified direction and stop it when contacting with the object.
Follow	Relax	Adjust the position of the robot so that the applied force and torque to the specified axis will be "0".
	FollowMove	While moving the specified trajectory, adjust the position of the robot so that the applied force and torque to the specified axis will be "0".
Align	SurfaceAlign	Align a surface of the grasped workpiece with that of the object.
Probe	PressProbe	Detect a hole or a step on the object while pressing the grasped workpiece.
	ContactProbe	Detect a hole on the object while contacting the grasped workpiece.

Category	Object name	Description
Press	Press	Press to the specified axis direction.
	PressMove	Press to the specified axis direction while moving the specified trajectory.
Execution	Decision	Processing branches off depending on the success or failure of the object.
	SPELFunc	Execute a function of the specified SPEL program.
System	Paste	Aligns the surface of the workpiece being gripped with the surface of the target object, and presses in the direction specified. . This is placed automatically when the Paste sequence is created.
	ScrewTighten	Tightens screws using an electric screwdriver. This is placed automatically when the ScrewTighten sequence is created.
	ScrewRetighten	Loosens, then retightens a screw tightened with an electric screwdriver. This is placed automatically when creating the ScrewTighten sequence with the screw retightening option enabled.
	HeightInspect	Stops the robot upon contact with a target object when moving in a specified direction, and measures and inspects the height of the object. This is placed automatically when the height inspection sequence is created.
	Insert	Inserts the workpiece. This is placed automatically when the Insert sequence is created.
	TensileTest	This confirms that an inserted workpiece cannot be removed by applying a force in the direction opposite to the direction of insertion after the insertion of a connector, etc. This is placed automatically when creating the Insert sequence with the tensile test option enabled.

Force guide object has properties and results.

- Properties
Generally speaking, properties affect force guide objects. For example, there is a property which sets a motion direction.
- Result
Display the result of force guide object in [Value].

Set force guide objects by the following steps:

- Step 3-1. Break down an operation into force guide objects
- Step 3-2. Align force guide objects
- Step 3-3. Set properties of force guide objects

4.4.1.3.1 Step 3-1. Break down an operation into force guide objects

Decide a force object to be used depending on operations which you want to realize by using force guide sequence.

The following describes the basic concept. Please be aware that some operations, such as complex operations, may not be applied to the basic concepts. Note that this Step can be skipped when using a system force guide sequence as system force guide objects are placed automatically. However, as system force guide sequences are purposely built as general operation sequences, you may need to add your own force guide objects in your own operations.

Begin by breaking down the operations that you want your force guide sequence to perform into categories ("Contact" "Follow" "Align" "Probe" "Press"). If you want to perform consecutive motions such as performing a "Press" motion after a "Follow" motion, divide the operation into two processes. Divide processes into a single category as much as possible. However, if you want to perform two categories simultaneously, temporary divide into either category depending on the major objective. For example, when moving a robot without considering a contact state, think how many Move commands will be used. Then, divide them into a category.

Next, use the following five flow charts to decide a force guide object.

"Contact"

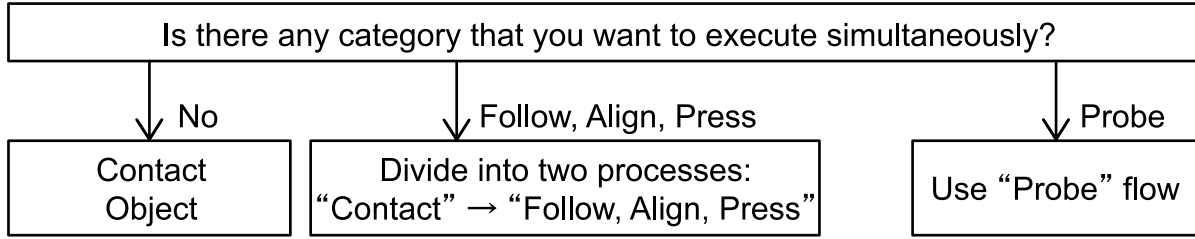

"Follow"

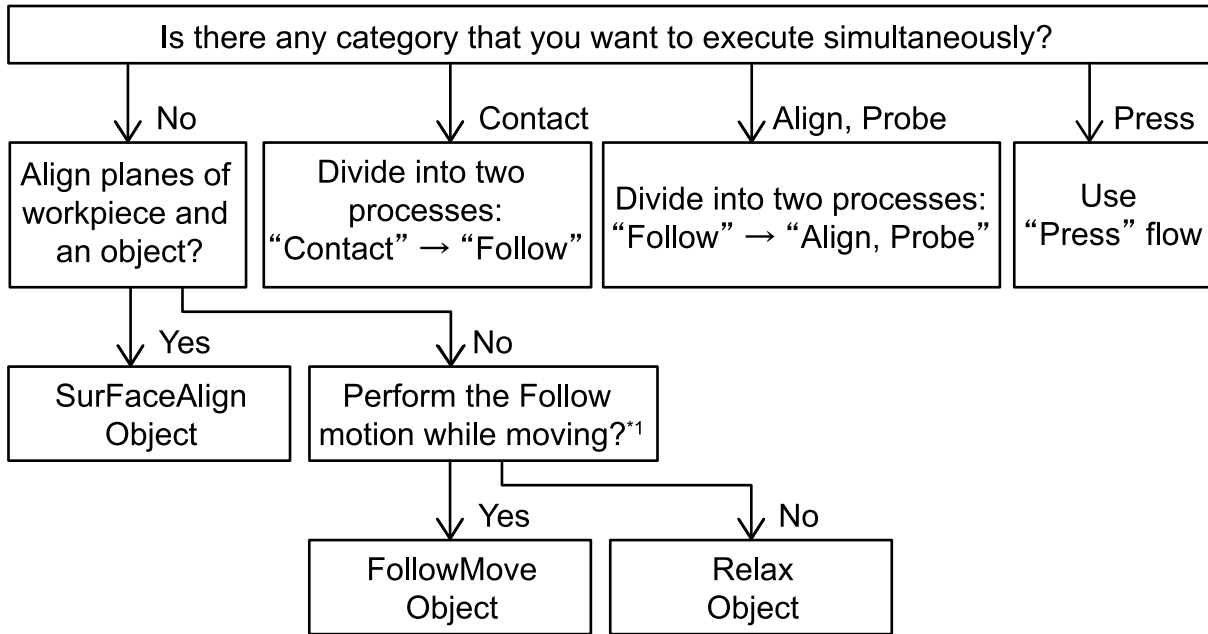

*1: This is when the robot Follows while moving along the specified trajectory. Select "No" when the robot moves by the force control function.

"Align"

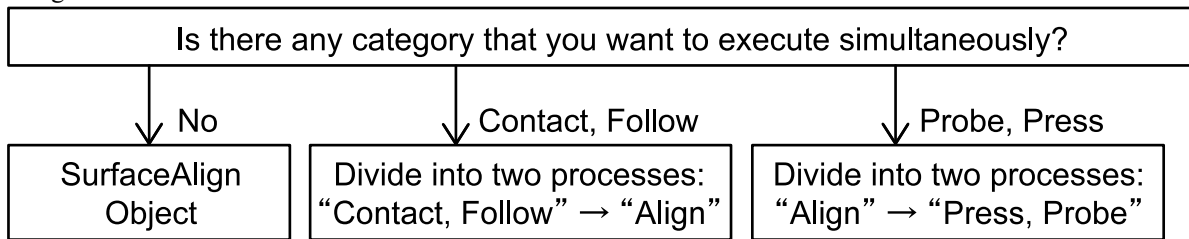

"Probe"

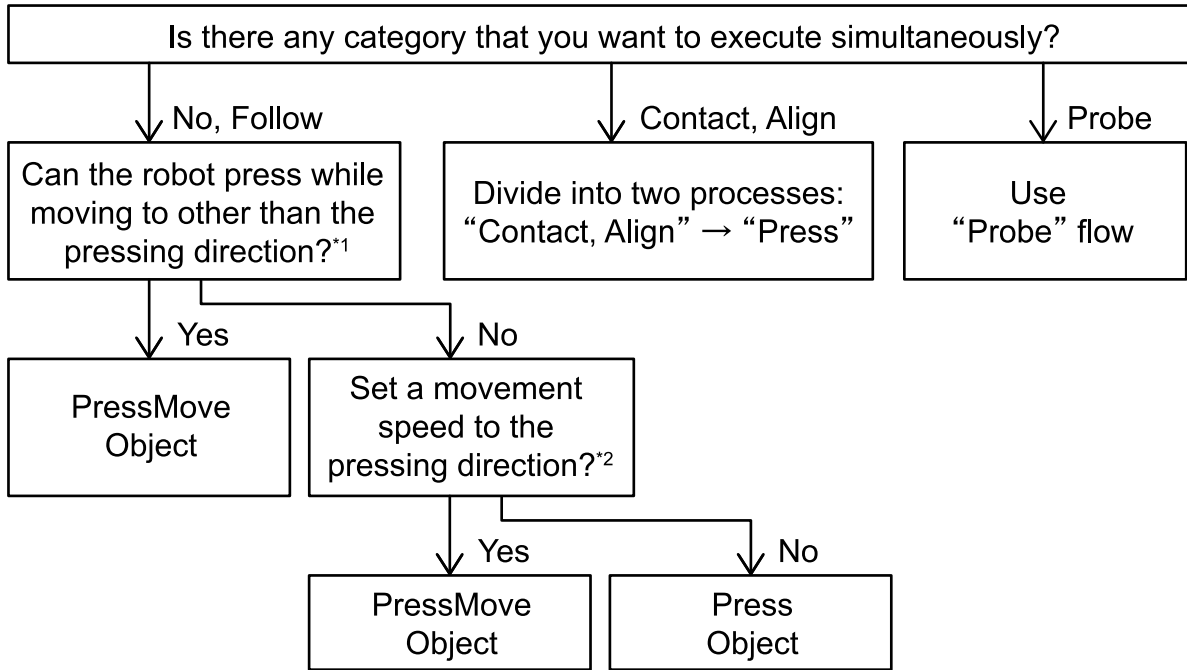

*1: Select "No" if workpieces such as lead parts get damaged or deformed by performing the PressProbe motion.

*If you considered "Contact" as a preceding process, delete it.

"Press"

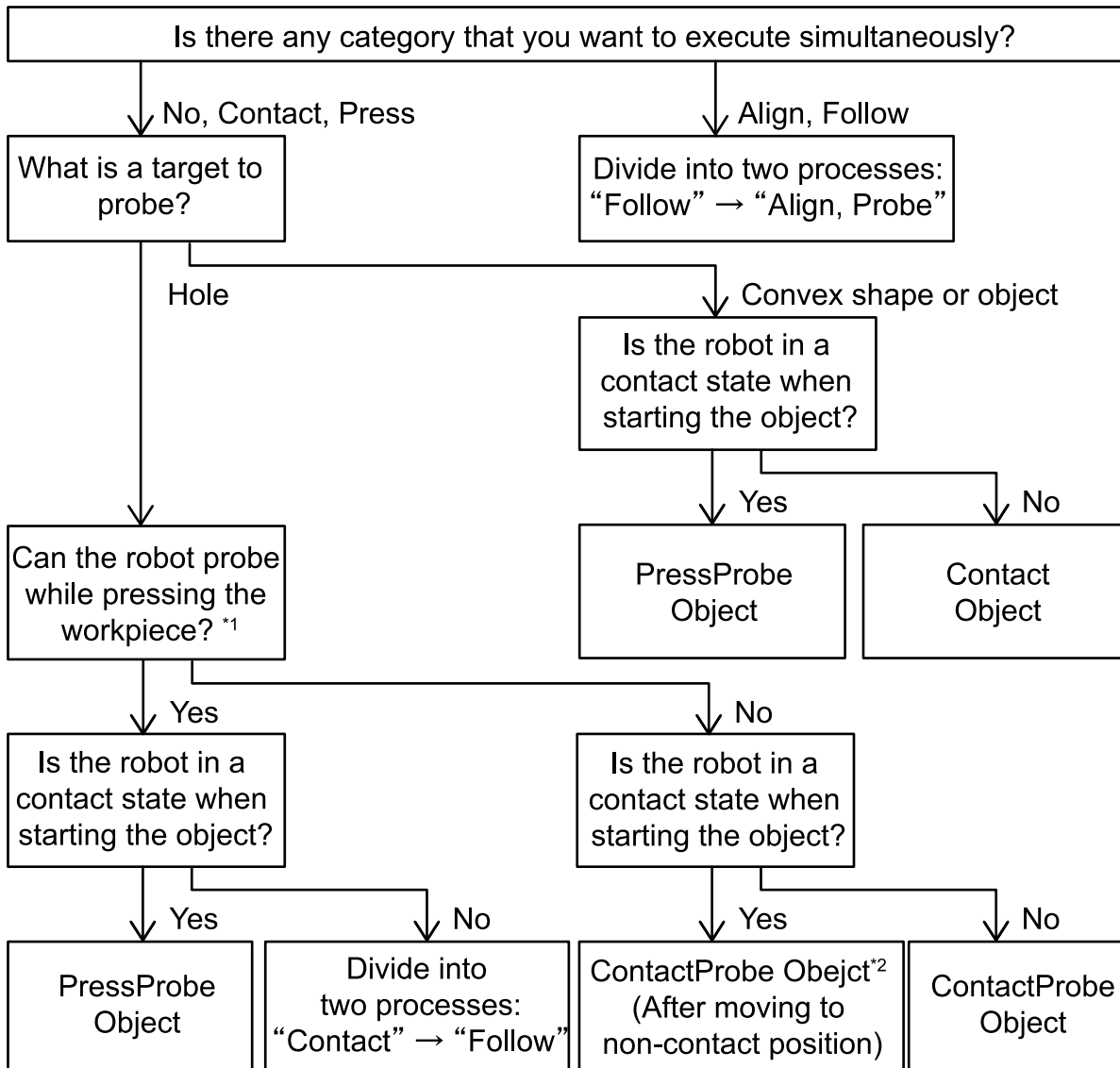

*1: This is when the force control function is used while the robot is moving along the specified trajectory. Select "No" when the robot moves by the force control function.

*2: This is when you need to set the speed depending on the workpiece or tool. Normally, select "No". For example, when performing screw driving by using an electric screw driver, select "Yes" since the speed to the pressing (screw insertion) direction is set by screw's pitch and rotation speed of the driver.

Example: Break down the pressing operation with a certain amount of force into force guide objects

It is an operation to press an object after contacting it. You can divide it into "Contact" and "Press" processes.

"Contact" will be the Contact object since there is no other category which is executed simultaneously.

"Press" will be the Press object because there is no other category which is executed simultaneously and because

"Press" moves in the pressing direction only and does not set a movement speed for the pressing direction.

Example: Break down the Peg In Hole task into force guide objects

It is an operation to perform the following motions: Probe a hole after contacting an object → follow it while adjusting → press to the hole direction → and insert To perform "Follow" and "Press" simultaneously, consider them as a single process. Temporarily classify it as "Press" since a major objective is insertion.

You can divide it into three processes: "Contact", "Probe", and "Press".

"Contact" will be the Contact object since there is no other category which is executed simultaneously.

"Probe" will be the PressProbe object because there is no other category which is executed simultaneously, because the Probe target is a hole (so it is possible to probe while pressing a workpiece), and because it is in the contact state when the object is started.

"Press" will be the Press object because the Follow category is executed simultaneously and because "Press" moves in the pressing direction only and does not set a movement speed for the pressing direction.

Example: Break down a connector insertion operation into force guide objects

It is an operation to perform the following motions: Contact an object → probe a hole → follow it while adjusting → press to the hole direction → and insert.

To perform "Follow" and "Press" simultaneously, consider them as a single process. Temporarily classify it as "Press" since a major objective is insertion.

You can divide it into three processes: "Contact", "Probe", and "Press".

"Contact" will be the Contact object since there is no other category which is executed simultaneously.

"Probe" will be ContactProbe object according to the following reasons. There is no other category which is executed simultaneously. Probe target is a hole. It is not possible to probe while pressing a workpiece and it is a contact state when starting the object.

Also, since it starts with the non-contact state, delete the preceding process: "Contact".

Although this operation was initially divided into three processes, it actually has two processes ("Probe" and "Press"), because "Contact" is deleted.

"Press" will be the Press object because the Follow category is executed simultaneously and because "Press" moves in the pressing direction only and does not set a movement speed for the pressing direction.

Example: Break down a screw driving operation by using an electric screw driver into a force guide object.

It is an operation to perform the following motions: Contact an object → follow it while adjusting → press to the hole direction → and insert.

However, screw may fall out when pausing after contacting with an object. Therefore, consider as a single process such as following while contacting an object, and press it. Temporarily classify it as "Press" since a major objective is insertion. This operation can be considered as a single process: "Press".

"Press" will be the PressMove object because the Contact and Follow categories are executed simultaneously and because "Press" moves in the pressing direction only and sets a movement speed for the pressing direction.

The following additional descriptions are for users who understand the force functions using SPEL+ programming.

Motions of the force guide objects with five basic motions consist of the force control function, position control, and end conditions. In each object, what you need for the motion can be selected or is set automatically. The following is a list of force guide objects:

Category	Object name	Force control function A: Optional B: Set automatically		Position control A: Execute simultaneously B: Execute separately	End condition A: Optional B: Set automatically		
		Press	Follow		Force	Position	I/O
Contact	Contact	A (1-axis only)	-	-	B	-	-
Follow	Relax	-	A (All axes)	-	A	A	A
	FollowMove	-	A (All axes)	A	-	A	A
Align	SurfaceAlign	A (translation, 1-axis only)	B *1	-	A	-	-
Probe	PressProbe	A (translation, 1-axis only)	-	A	A *2	A *2	-
	ContactProbe	A (translation, 1-axis only)	-	B *3	B	B	-
Press	Press	A (All axes)	A (All axes)	-	A	A	A
	PressMove	A (All axes)	A (All axes)	A	A	A	A
Execution	Decision	-	-	-	-	-	-
	SPELFunc	-	-	-	-	-	-

Category	Object name	Force control function A: Optional B: Set automatically		Position control A: Execute simultaneously B: Execute separately	End condition A: Optional B: Set automatically		
		Press	Follow		Force	Position	I/O
System	Paste	A (1-axis only)	B	-	B	B	-
	ScrewTighten	A (1-axis only)	B	A *4	B	B	B
	ScrewRetighten	B (Same direction as ScrewTighten)	B	A	B	B	B
	HeightInspect	A (1-axis only)	-	-	B	B	-
	Insert	A (1-axis only)	B	A *4	B	B	-
	TensileTest	B (Reverse direction of Insert)	-	-	B	B	-

- *1: The rotational directions are set for the two axes which are perpendicular to the axis which is set for the pressing direction.
- *2: One or the other must be enabled.
- *3: Use position control for the depart motion, as well as the next movement to the contact start position. It cannot be executed with the force control function simultaneously.
- *4: In the middle of the operation, the simultaneous execution with the position control is switched to the force control function only.

4.4.1.3.2 Step 3-2. Align force guide objects

Force guide objects are selected and aligned on the [Force Guide] window. Align the force guide objects which are set in Step 3-1 in order.

If a template is selected when creating a force guide sequence, you do not need to align the force guide objects. Depending on an operation, you can add force guide objects to the template or delete the force guide objects.

When you select the system force guide sequence when creating the force guide sequence, you do not need to align the force guide objects. The system force guide objects required for each sequence are automatically aligned. The aligned system force guide objects cannot be deleted or moved. You can also add the general force guide objects if the additional motion is required. For more details on the creation steps, refer to the following section.

Software [\[Force Guidance\] \(Tools Menu\)](#)

4.4.1.3.3 Step 3-3. Set properties of force guide objects

Set properties of the force guide objects. You need to set properties depending on an operation. You can set the properties of the system force guide object in the sequence wizard.

For more details on each property, refer to the following section.

[General force guide object](#)

[Paste Object](#)

[ScrewTighten Object](#)

[ScrewRetighten Object](#)

[HeightInspect Object](#)

[Insert Object](#)

[TensileTest Object](#)

For more details on each property, refer to the following section.

Software [\[Force Guidance\] \(Tools Menu\)](#)

The following describes some concepts that you should know when setting properties of the force guide object.

Basic robot motion when executing force control function

Force control function maintains force or torque in the specified value. To maintain the value, the robot moves to a position where the force will be applied. Therefore, if you use a force control function which specifies "Press" in the non-contact state, the robot moves toward the position where the force is expected to be applied.

Force direction and robot motion direction

Force Sensor detects the applied force.

In the example below, the robot presses a workpiece to vertical-downward (the direction shown as a red arrow). Since the force is balanced, the reaction force (blue arrow) is applied to the robot while the robot applies the action force (red arrow).

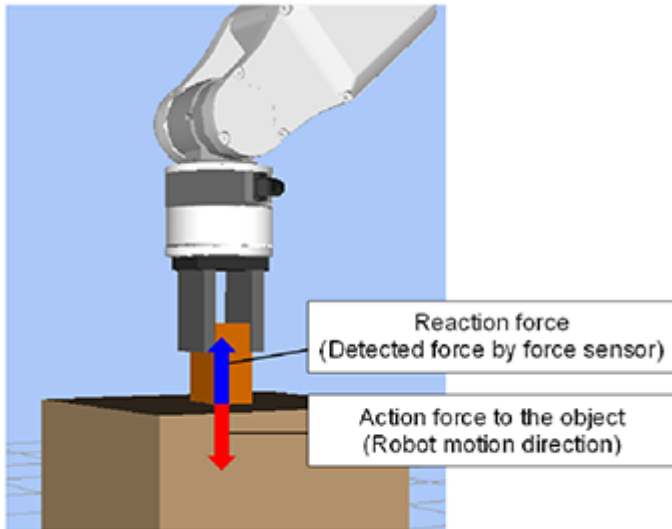

Force Sensor is a sensor to detect the reaction force. Be careful that the direction between the robot motion direction and the pressing force/detection force to be set are always opposite.

For example, if you specify Press+ (pressing in the positive direction) in the Press object's Fx_ControlMode, you need to set a negative value to Fx_PressForce. The force recorded as the motion result will also be a negative value.

Firmness of force control function (Firmness)

Force guidance function indicates the firmness of the force control function in Firmness property.

Actual property name is different depending on the force guide object such as ContactFirmnessF or Fx_Firmness. Features are the same.

The following describes the common concepts of the Firmness property.

When the Firmness property is large, force control function will be firm and reaction will be slow.

When the Firmness property is small, force control function will be soft and reaction will be fast. However, if the Firmness property is too small, the robot motion may vibrate.

As shown in the figures below, the robot starts the motion above the object and presses the grasped workpiece with 10 [N]. Use this operation as an example and describe effects of the Firmness property.

The following is a graph of force when fixing other properties and executing with the both large and small values of the Firmness property.

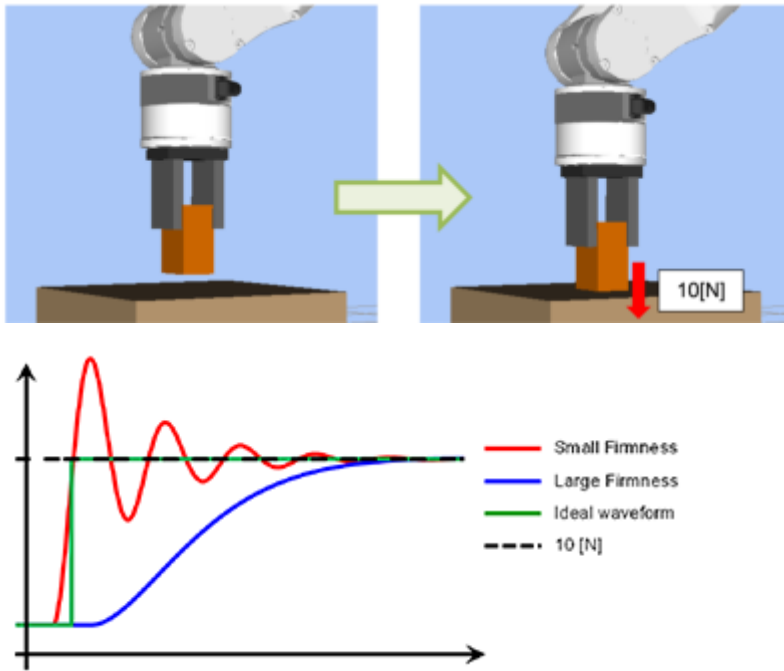

In the non-contact state, when the Firmness property is smaller, the movement speed will be faster. Therefore, the time to contact with an object will be shortened and the time to start rising up the waveforms in the graph will be different. Since the contacting speed is fast, overshoot of the force will be large. Time to reach a target force will be shortened, however, vibrations may be generated.

An ideal force change by using the force control function is the green line (ideal waveform) in the graph. The force does not overshoot when contacting and become a target force immediately, and it is stable. However, it is not possible to realize the ideal force change in actual operation since the relation between the overshoot or vibrations of the force and the cycle time is a trade-off. Please perform proper adjustments for your operations.

Relationship between the Firmness property value and the force when executing changes with the environment (robot, hand, workpiece, position). Therefore, you need to adjust each force guide object in the actual environment. We recommend setting a large value for the initial state of the Firmness property, then adjusting it by gradually decreasing the value (e.g. in increments of 10%).

The Firmness value can also be adjusted in the Firmness Wizard. The following section describes the procedure for adjusting Firmness using the Firmness Wizard.

1. Click the  button on the right side of the Firmness property.
The [Firmness Wizard] window is displayed.

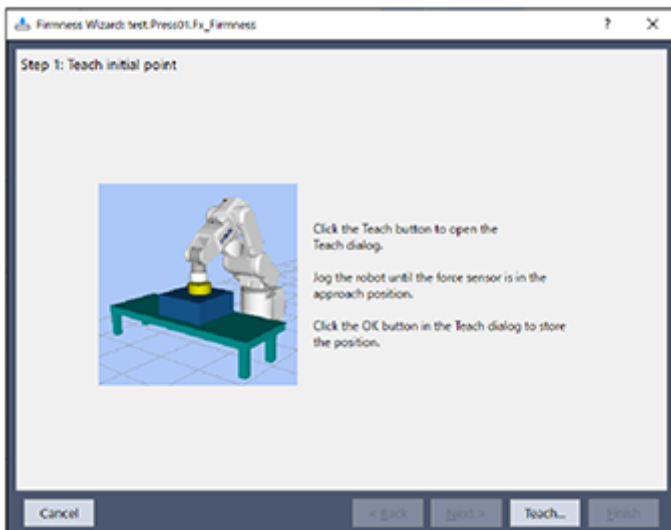

2. Click the [Teach...] button.

The [Teach Approach Point] dialog box is displayed.

Move the workpiece until it is 1 mm above the object to be pressed.

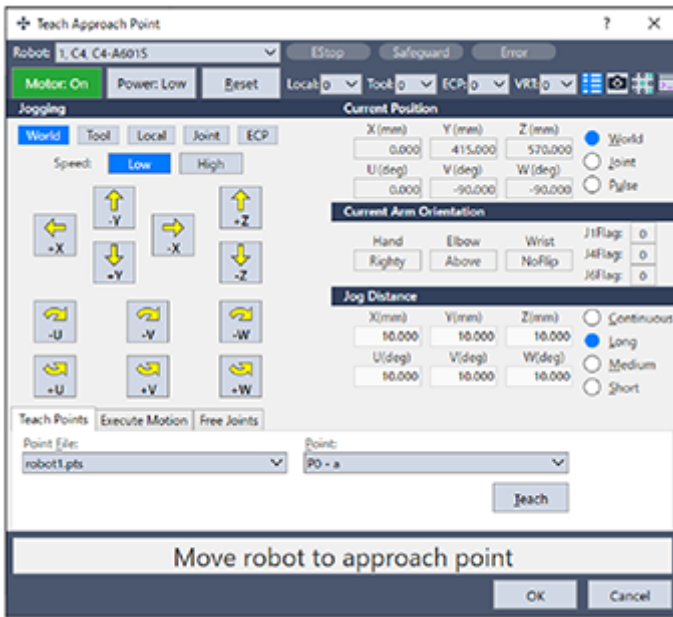

3. Click the [OK] button.

This will save the current position and return you to the [Firmness Wizard] window.

Set the max force, or torque tolerated under [Motion and Force].

When the Firmness Wizard is set in the motion following direction, set the force or torque that is expected to be applied.

Set the value of trials and the maximum time per trial for [Firmness], as well as the Firmness range using the sliders.

When starting adjustments, set a slider to the hard side, and then adjust using measured waveforms for force or torque.

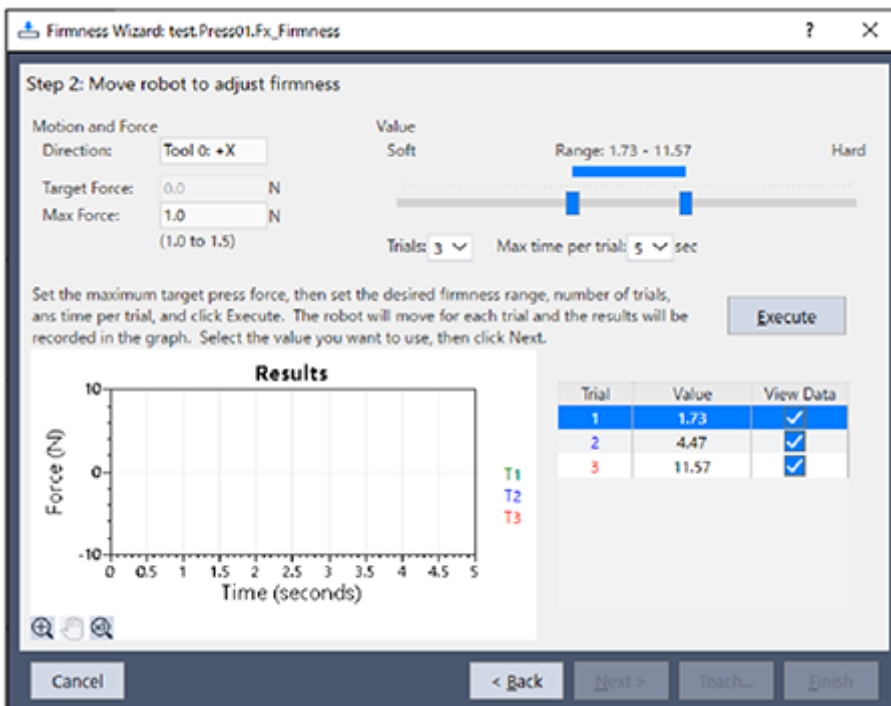

4. Click the [Execute] button. A confirmation dialog box is displayed.

Check that the workpiece in its initial position is within 1 mm of the object to be pressed, and then click [Yes].

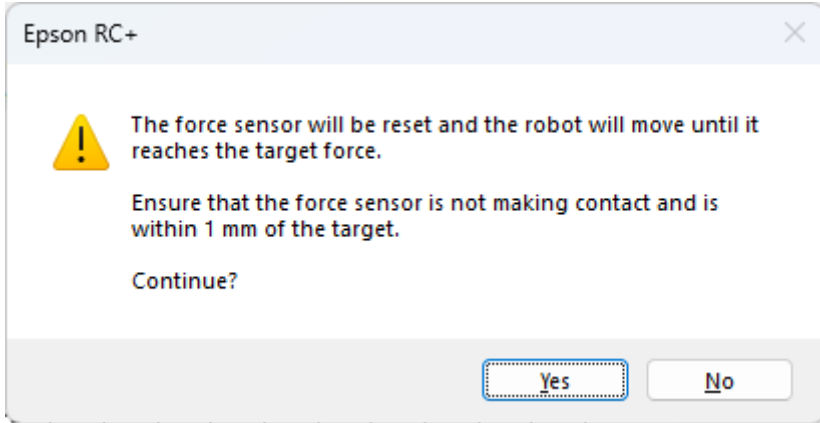

5. The robot will move until the designated axis reaches the target force.

To stop the robot during movement, click the [STOP] button.



6. If the robot moves 10 mm or 10 deg or more before reaching the target force or torque, the following dialog box will appear. This could be due to the following.

- The distance between the workpiece in its initial position and the object to be pressed is 10 mm or 10 deg or more.
- The direction of pressing is set to a different direction to that expected.

To continue the remaining trials, click the [Yes] button. To cancel any remaining trials, click the [No] button.

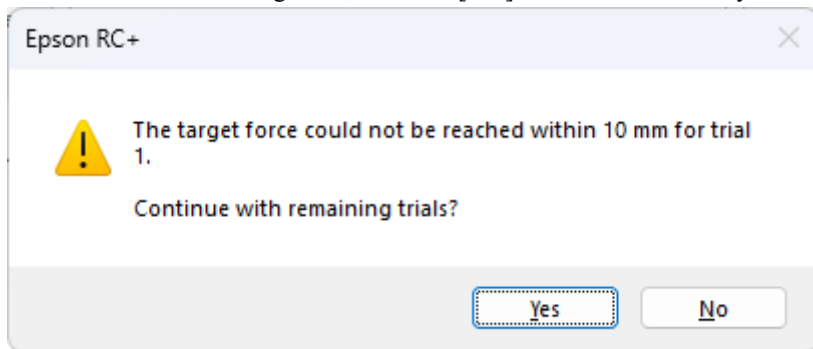

7. Adjust the sliders so that the measured data for force or torque approaches an acceptable waveform for the operation being performed, and then click the [Execute] button.

Repeatedly change the slider range and execute this process until arriving at an ideal waveform.

When the waveform is vibratory or not set to the target force, move the slider to the Hard side. When the waveform is too

gentle, move the slider to the Soft side. When you move the slider too much, the force applied may change significantly. Move the slider gradually.

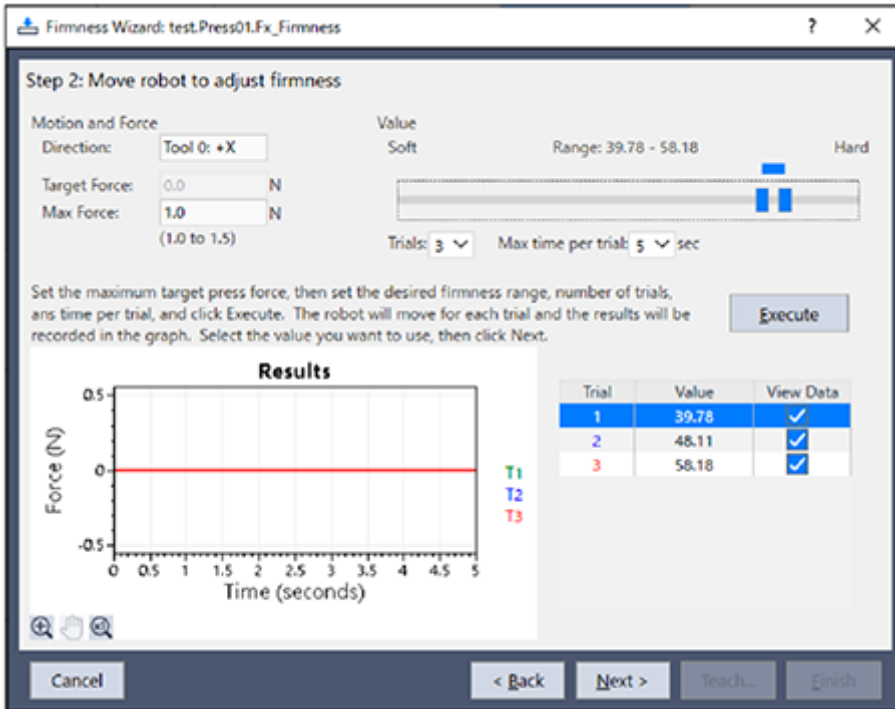

8. Click the [Next] button.

The Firmness values before and after appearing here.

To save a new value, click the [Finish] button. To cancel, click the [Cancel] button.

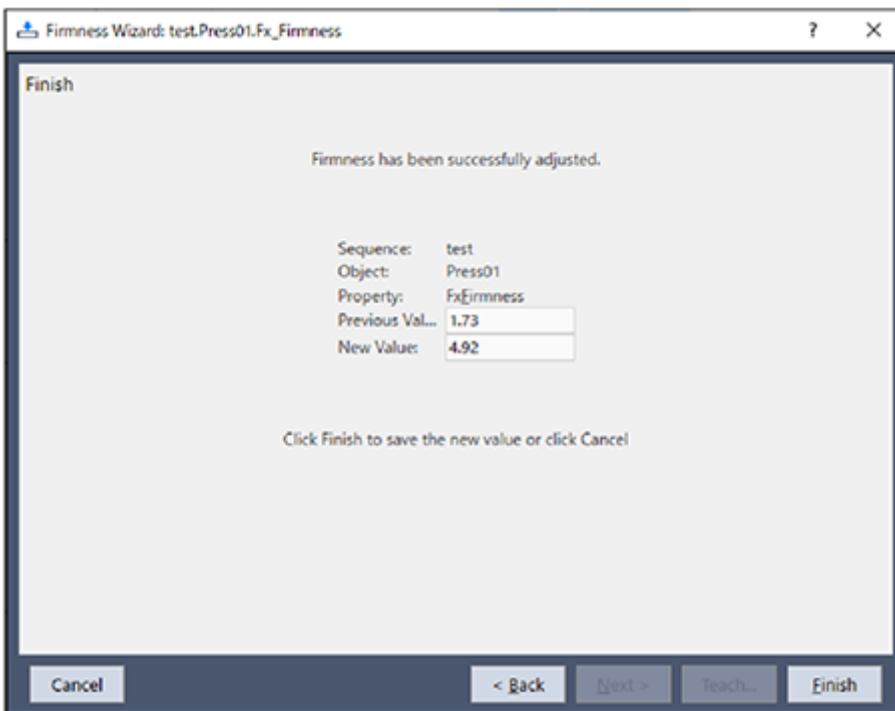

4.4.1.4 Adjust While Executing Test

Adjust the created force guide sequence.

Perform the test execution on the [Force Guide] window. We recommend adjusting a force guide sequence only as much as possible. If it is necessary to connect with other devices, you can adjust while executing as SPEL+ programming.

Perform the test execution and adjust a property of the force guide object with the force, position, and result when executing.

To adjust each object, refer to the following section.

General force guide object

Paste Object

ScrewTighten Object

ScrewRetighten Object

HeightInspect Object

Insert Object

TensileTest Object

To perform the test execution or check the force or position when executing, refer to the following section.

Software **[Force Guidance] (Tools Menu)**

We recommend starting the adjustment in low power. After confirming that the rough motions are correct, perform the adjustment in high power. When performing a final adjustment, perform the adjustment in the same power as when using the force guide sequence. When adjusting in low power, the maximum speed or the maximum acceleration is limited not to exceed the limitation of the low power. Therefore, when you switch the power to different mode, conditions will be changed and re-adjustment will be necessary.

In the [Force Guide] window, you can execute the force guide objects one by one by the step execution function. Also, by setting a breakpoint, you can stop the force guide sequence in front of an object. Main objective of this is to confirm that the rough motions are correct at the early stage of adjustment. To adjust parameters, click the [Run] button without setting breakpoints. When pausing the force guide sequence by the step execution or breakpoints, the operation may be affected by the force which is applied until the next force guide object starts or the force control function which is kept working during the pause. If you perform adjustment in this state, re-adjustment will be required since the conditions are changed.

4.4.1.5 Execute a force guide sequence using the SPEL+ language

You can call up and execute the adjusted force guide sequence by using FGRun statement from SPEL+ language.

The following is an example to add FGRun statement. Add to the following example.

Using the SPEL+ Language to Create Motions Prior to Starting Force Control Function

```
Function main
  Motor On
  Go P1          'Go to the start position
  FGRun MyFGSeq 'Execute the created force guide sequence
Fend
```

Execute it as the whole SPEL+ programming including the force guide sequences.

If there is an error in the force guide sequence, return to

Adjust While Executing Test

You can adjust it while executing as the whole SPEL+ programming.

An error may occur when executing the sequence as the whole SPEL+ programming even though the operations are normal when performing the test execution of the single force guide sequence. In that case, you need to adjust the sequence as the whole SPEL+ programming.

Executed results can be acquired as results of force guide sequence or force guide object. Result has force or position at the end of the operation and success/failure.

The following is an example to execute a force guide sequence and acquire the force when the sequence ends.

```
Function main
  Double dEndForce (6)
  Motor On
  Go P1          'Go to the start position
  FGRun MyFGSeq 'Execute the created force guide sequence
  FGGet MyFGSeq.EndForces, dEndForce() 'Acquire the force when the force guide
sequence ends.
Fend
```

For more details on FGRun, FGGet, and results, refer to the following manual.
 "Epson RC+ 8.0 Option Force Guide 8.0 SPEL+ Language Reference"

4.4.2 General Sequence and Object

The following describes properties of the general force guide sequences and general force guide objects, and its setting steps.

4.4.2.1 General Sequence

The following describes properties of general sequences and how to set them up.

4.4.2.1.1 Property setting guidelines for general sequence

General setting steps and setting methods for each property are as follows:

Step 1. Set basic information

Set properties (Name, Description, RobotNumber, AutoStepID) related to the basic information.

Properties	Description
Name	Force guide sequence name. Set a particular name.
Index	Particular number for a force guide sequence. It is assigned automatically. You cannot set this.
Description	Descriptions for force guide sequence. Describe the tasks. Set a character string.
Version	A compatible version of the sequence. The sequence operates with the specified version function.
RobotNumber	Robot number to execute a force guide sequence. Set a robot number to be executed.
RobotType	Robot type which is set by RobotNumber. You cannot set this.
AutoStepID	Set whether to set StepID of force guide object automatically. StepID is an ID which is recorded in the log data. It helps you to understand which log data support a process. True: Normal False: When you want to set StepID manually.

Step 2. Set for correction of sensor value

Set properties (ResetSensor, MPNumber) related to sensor value correction.

Properties	Description, setting guide
ResetSensor	Set whether to reset the Force Sensor when executing a force guide object other than Decision object and SPELFunc object for the first time during the force guide sequence execution.
	True: When a workpiece has not been in contact with anything at the start of the force guide sequence. (Normally, it is in the non-contact state at the start of the force guide sequence.)
	False : Used in rare cases, such as when a force guide sequence is executed, and then another force guide sequence is executed with the contact state unchanged.

Properties	Description, setting guide
MPNumber	Specify the number of Mass Property Object which is used during the force guide sequence execution. Mass Property Object is a collection of properties using for gravity compensation.
	"0": When the orientations (U, V, W) do not change largely during the force guide sequence execution.
	Created Mass Property number: When the orientations change greatly during the force guide sequence execution.
	For more details on Mass Property, refer to the following section. Software Gravity Compensation

Step 3. Set for coordinate system of force control function

Set properties (ForceOrient, RobotLocal, RotationCenterType, RotationCenterTLX, RotationCenterTLY, RotationCenterTLZ) related to a coordinate system of the force control function.

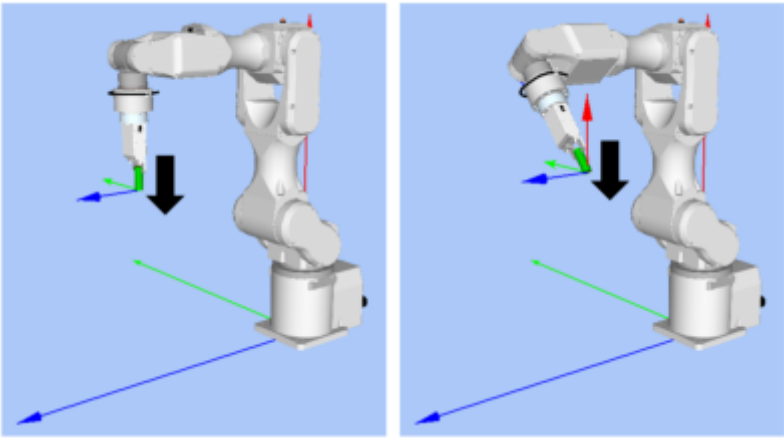
Properties	Description, setting guide
ForceOrient	Set a coordinate system direction which executes the force control function.
	<p>Base, Local:</p> <p>When you want to execute the force control function to a defined direction as viewed from outside, such as pressing to vertical-downward, even if the start orientation of force guide sequence is changed.</p> <p>Local is specified when a defined direction is different from the axis of the Base coordinate system. The following is an example to set Base.</p> <p>When pressing to -Z direction, the robot always presses to the vertical-downward (-Z direction in Base coordinate system) even the orientation of end effector changed. (Black arrow is a direction of the robot motion.)</p> 

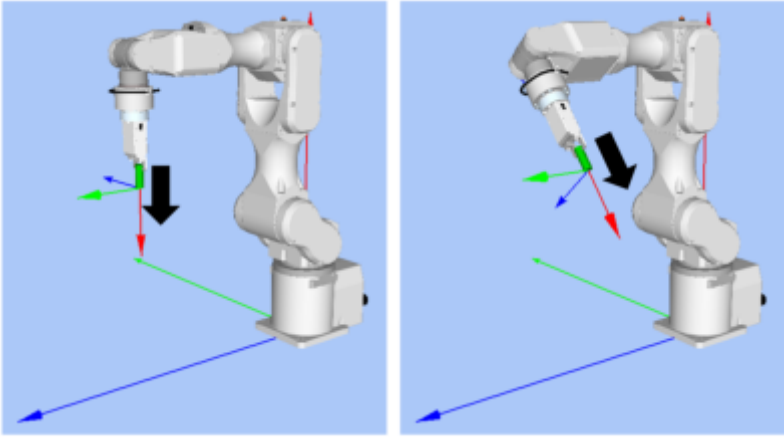
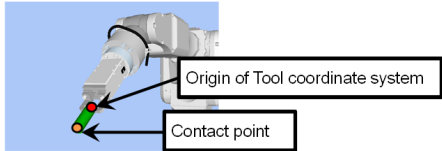
Properties	Description, setting guide
	<p>Tool: When you want to execute the force control function depending on an orientation at the start. The following is an example to set Tool. When pressing to +Z direction, the pressing direction changes depending on the orientation of end effector at the start.</p> 
RobotLocal	Set Local coordinate system number which is used when ForceOrient is Local.
RotationCenterType	Set a type of the rotation center setting when executing the force control function.
	<p>Relative: As shown in the following image, when an origin of Tool coordinate system is far from a contact point: We recommend setting a rotation center of the force control function to the contact point. However, basically be sure to set Tool coordinate system so that the contact point will be an origin of Tool coordinate system.</p> 
	<p>CurrentTool: When the origin of Tool coordinate system and the contact point are close or the force control function in the rotational direction is not used during the force guide sequence execution.</p>
RotationCenterTLX	When RotationCenterType is Relative, set an offset amount to each axis from Tool coordinate system to the rotation center.
RotationCenterTLY	
RotationCenterTLZ	

You can check the settings related to the coordinate system of the force control function by using a simulator. However, if no force guide object is aligned in the force guide sequence, check the setting after adding the force guide objects.

For details on how to check by using simulator, refer to the following manual.

"Epson RC+ 8.0 User's Guide: - Simulator - Description of Functions"

Step 4. Set the maximum speed and the maximum acceleration

Set properties (LimitAccelS, LimitAccelR, LimitSpeedS, LimitSpeedR) related to the maximum speed and the maximum acceleration.

Properties	Description, setting guide
LimitSpeedS LimitSpeedR	Set a maximum speed during the execution of the force guide sequence. LimitSpeedS: Maximum translational speed LimitSpeedR: Maximum rotational rotation speed In the force control function, the speed changes depending on the how the force is applied. It is controlled not to exceed LimitSpeedS and LimitSpeedR.
LimitAccelS LimitAccelR	Set a maximum acceleration during the execution of the force guide sequence. LimitAccelS: Maximum translational acceleration LimitAccelR: Maximum rotational rotation acceleration In the force control function, the acceleration changes depending on how the force is applied. It is controlled not to exceed LimitAccelS and LimitAccelR. If the value is small, reaction when the force is applied will be slow and the robot will bounce largely. Set a larger value when the robot bounces. When the robot vibrates, set the value smaller.

Step 5. Set conditions about recording

Set properties (LogRobotLocal, LogFileEnabled, LogFileAutoName, LogFileNameVar, LogFileMaxTime, LogFileInterval) related to recording.

Properties	Description, setting guide
LogRobotLocal	Set a Local coordinate system number which will be a reference of the recording robot position. Log data related to positions is recorded as positions of the specified Local coordinate system.
	Base: Normal
	Local coordinate system number: When you want to record as a position in the specified Local coordinate system
LogFileEnabled	Set whether to save the log data which is executing a force guide sequence to a file.
	False: It is not saved in a file. You can check the log data on the graph of force guide window when executing.
LogFileAutoName	Set whether to set the log data file name automatically.
	True : When Automatically set Is generated by the force guide sequence name and the start time. "Force guide sequence name_yyyymmdd_hh:mm:ss.ms"
	False: When specifying a name
LogFileNameVar	Set a global variable which indicates a log data file name when LogFileAutoName is False.
LogFileInterval	Set a sampling interval of log data when creating files.
LogFileMaxTime	Set a maximum time of log data when creating files.

Step 6. Set about checking of start position

Set properties (PointFile, RobotTool, PosCheckEnabled, OrientCheckEnabled, StartCheckPoint, StartPointTolLocal, StartPointTolX, StartPointTolY, StartPointTolZ, StartPointTolRot) related to the checking of start position.

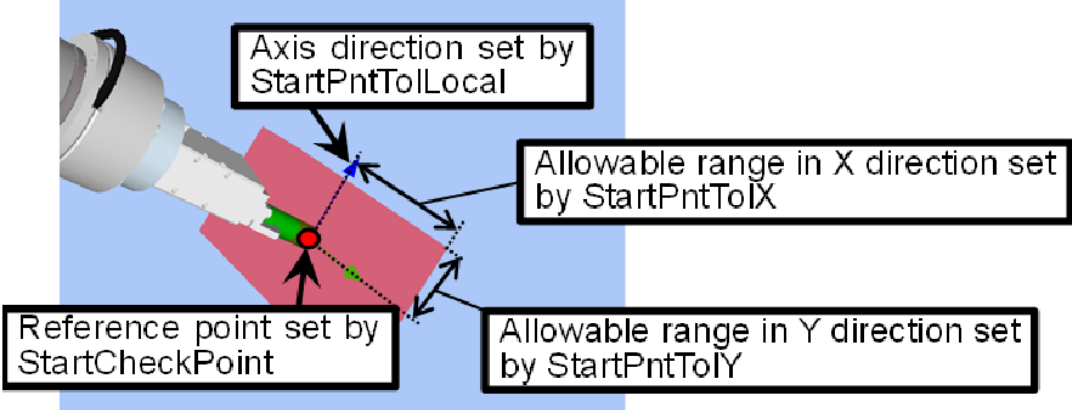
Properties	Description, setting guide
PointFile	<p>Set a point file which will be used in a force guide sequence.</p> <p>An error occurs when the specified point file is not loaded at the start. This is a property for preventing a wrong operation.</p> <p>If a point file is not set, any point file whichever loads is executed.</p>
RobotTool	<p>Set a tool number which will be used in a force guide sequence.</p> <p>An error occurs when the set tool number is not selected at the start. This is a property for preventing a wrong operation.</p>
PosCheckEnabled	<p>Set whether to check that the position (X, Y, Z, U, V, W) at the start is within the specified range. When the robot moves after detecting a start position by using Vision, check that the position is within the range. When it is out of the range, the force guide sequence ends as failure. Error is not caused.</p> <p>When it failed, a recovery such as moving to other start position is available.</p> <p>The following is an image of setting a range.</p> <p>Red part is an allowable range. Set ranges for each property.</p> <p>Also, though it is not shown in the following image, set the allowable ranges in Z direction and rotational direction by StartPntTolZ and StartPntTolRot.</p>  <p>True : When checking the position and orientation</p>
OrientCheckEnabled	<p>Set whether to check that the arm orientation (Hand, Elbow, Wrist) at the start is matched the set state.</p> <p>When the robot moves after detecting a start position by using Vision, you can check that the arm orientation is the assumed one.</p> <p>When the arm orientation is not matched, the force guide sequence ends as failure. Error is not caused.</p> <p>When it failed, a recovery such as moving to other start position is available.</p> <p>True : When checking the arm orientation</p>
StartCheckPoint	<p>Set a point number which will be a reference for checking the position or the arm orientation at the start.</p>
StartPntTolLocal	<p>When PosCheckEnabled is True, set a Local coordinate system number which will be a reference of the allowable error direction.</p> <p>Only the axis direction is used. The origin position in Local coordinate system does not affect.</p>
StartPntTolX	<p>Set an allowable range in each direction in Local coordinate system specified by StartPntTolLocal.</p>
StartPntTolY	<p>In X direction, an allowable range is a reference position \pmStartPntTolX.</p>
StartPntTolZ	<p>The allowable range in Y and Z directions are the same way.</p>

Properties	Description, setting guide
StartPntTolRot	Set an allowable range of the rotational direction. The allowable range is a reference orientation \pm StartPntTolRot. It is set for all U, V, and W directions.

4.4.2.1.2 Details on properties of general sequences

- Name Property

This property sets a particular name that is assigned to force guide sequences. You cannot create the force guide sequence with the same name.

You can change the name. Set up 16 characters at the maximum. Please use alphanumeric characters and underscores [_].

Note: The initial character cannot be a numeric character.

- Index Property

This property displays a number of force guide sequence. This property is set and updated automatically. It cannot be edited.

	Value
Minimum Value	1
Maximum value	32

- Description Property

This property sets a description of force guide sequence. You can set the character string up to 255 characters.

- Version Property

This property sets a compatible version when running the force guide sequence.

The force guide sequence operates with the functions supported by the specified version.

Value	Description
7.4.0	The sequence operates with the functions supported by 7.4.0.
7.5.1	The sequence operates with the functions supported by 7.5.0.

- RobotNumber Property

This property sets a robot number that uses a force guide sequence. An error occurs when executing the force guide sequence by the robot which is not specified.

Value	Description
1 to 16	Robot number to use a force guide sequence.

Default: Robot number specified in the sequence wizard.

- RobotType Property

This property is the robot types that use a force guide sequence. It is automatically set from the robot number specified by RobotNumber. It cannot be edited.

- AutoStepID Property

This property sets an automatic assignment of StepID in force guide object execution.

When assigning a StepID automatically, it is set to the force guide sequence number*100 + the force guide object number. StepID is recorded to files that the force and the position during the force guide sequence execution is recorded. It is used to determine which interval corresponds to which force guide object.

Value	Description
True	Set StepID automatically.

False	Set a property value of StepID of each force guide object.
-------	--

Default: True

▪ **ResetSensor Property**

This property sets whether to reset a Force Sensor when starting force guide object other than Decision object and SPELFunc object for the first time in the force guide sequence.

Value	Description
True	Reset the Force Sensor when starting a force guide object other than Decision object and SPELFunc object.
False	Force Sensor is not reset.

Default: True

▪ **MPNumber Property**

This property sets the number of Mass Property Object which is used during the force guide sequence execution. Mass Property Object is a collection of properties using for gravity compensation. You need to define Mass Property Object in advance. If an angle will change largely during the execution of the force guide sequence, make sure to specify the proper Mass Property Object.

Value	Description
0	Turn OFF the gravity compensation.
1 to 15	Use the specified Mass Property.

Default: 0

▪ **ForceOrient Property**

This property specifies the direction of coordinate system that uses the force control functions during the force guide sequence execution.

You can select from Base, Local, and Tool. Normally, specify the coordinate system that the direction you want to press or follow is either of X, Y, or Z.

If Base or Local is specified, the direction to press or follow will not be changed even if the robot orientation changes.

If Tool is specified, the direction to press or follow changes since the direction of Tool coordinate system changes when the robot orientation is changed.

Value	Description
Base	The direction of the coordinate system to which the force control function is applied is the Base coordinate system
Local	The direction of the coordinate system to which the force control function is applied is the Local coordinate system
Tool	The direction of the coordinate system to which the force control function is applied is the Tool coordinate system

Default: Tool

▪ **RobotLocal Property**

This property specifies the Local coordinate system number of coordinate system that applies the force control functions during the force guide sequence execution.

It is used when ForceOrient property is Local.

Value	Description
0 (Base)	Use the Local 0 coordinate system (Base coordinate system). It is the same as when specifying Base in ForceOrient.

Value	Description
1 to 15	Use the Local coordinate system of the specified number.

Default: 0 (Base)

■ **RotationCenterType Property**

This property specifies the type of the rotation center which rotates due to the adjustments of the force control functions during the force guide sequence execution.

When specifying CurrentTool, rotate around the selecting Tool coordinate system. When specifying Relative, rotate around the relative position from the Tool coordinate system which is specified below.

RotationCenterTLX, RotationCenterTLY, RotationCenterTLZ

Value	Description
CurrentTool	Set a position of the currently selected Tool coordinate system as a center of rotation.
Relative	Set a position where is apart from the currently selected Tool coordinate system by the specified distance as a center of rotation.

Default: CurrentTool

■ **RotationCenterX Property**

When RotationCenterType is Relative, this property sets a distance in X direction to the rotation center of the force control function.

It is the X direction of the Tool coordinate system which is selected in RobotTool.

	Value (Unit: [mm])
Minimum Value	-2000
Maximum value	2000

Default: 0

■ **RotationCenterY Property**

When RotationCenterType is Relative, this property sets a distance in Y direction to the rotation center of the force control function.

It is the Y direction of the Tool coordinate system which is selected in RobotTool.

	Value (Unit: [mm])
Minimum Value	-2000
Maximum value	2000

Default: 0

■ **RotationCenterZ Property**

When RotationCenterType is Relative, this property sets a distance in Z direction to the rotation center of the force control function.

It is the Z direction of the Tool coordinate system which is selected in RobotTool.

	Value (Unit: [mm])
Minimum Value	-2000
Maximum value	2000

Default: 0

■ **LimitSpeedS Property**

This property sets the maximum speed during the execution of force guide sequence.

The robot motion will change depending on applied force and torque when executing the force guide sequence since it is adjusted by the force control functions. However, it is restricted by the speed which is specified by this property.

	Value (unit: [mm/sec])
Minimum Value	0.1
Maximum value	250

Default: 50

■ LimitSpeedR Property

This property sets the maximum rotation speed during the execution of force guide sequence.

The robot motion will change depending on applied force and torque when executing the force guide sequence since it is adjusted by the force control functions. However, it is restricted by the rotation speed which is specified by this property.

	Value (unit: [deg/sec])
Minimum Value	0.1
Maximum value	180

Default: 25

■ LimitAccelS Property

This property sets the maximum acceleration during the execution of force guide sequence.

The robot motion will change depending on applied force and torque when executing the force guide sequence since it is adjusted by the force control functions. However, it is restricted by the acceleration which is specified by this property.

	Value (unit: [mm/sec ²])
Minimum Value	0.1
Maximum value	25000

Default: 200

■ LimitAccelR Property

This property sets the maximum rotation acceleration during the execution of force guide sequence.

The robot motion will change depending on applied force and torque when executing the force guide sequence since it is adjusted by the force control functions. However, it is restricted by the rotation acceleration which is specified by this property.

	Value (unit: [deg/sec ²])
Minimum Value	0.1
Maximum value	5000

Default: 100

■ LogRobotLocal Property

For the positional orientation of the robot that is recorded during the force guide sequence execution, set a reference local coordinate system number.

The position of the robot is recorded as that of Tool coordinate system as viewed from the Local coordinate system specified by this property.

Value	Description
0 (Base)	Use the Local 0 coordinate system (Base coordinate system).
1 to 15	Use the Local coordinate system of the specified number.

Default: 0 (Base)

■ LogFileEnabled Property

This property sets whether to save the force, torque, and the position of the robot during the force guide sequence execution in files.

When specifying True, value will be displayed in the graph on the monitor and saved in the files simultaneously. When specifying False, value will be displayed in the graph on the monitor. However, the value is not saved in the files.

Value	Description
True	Save the log data in a file.
False	The log data is not saved in a file.

Default: False

■ LogFileAutoName Property

This property sets whether to automatically set the file name that records force, torque, and the position of the robot during the force guide sequence execution.

When specifying True, the file name is automatically set with the force guide sequence name + start time.

Force guide sequence name_yyyymmdd_hhmmssfff.csv

When specifying False, add ".csv" to the string in variables which is specified in LogFileNameVar to make it a file name.

Value	Description
True	Set the name of the log data file automatically.
False	Set a log data file name to the one which is specified by LogFileNameVar.

Default: True

■ LogFileNameVar Property

This property sets a global string variable that saves a file name which records force, torque, and the position of the robot during the force guide sequence execution.

It is used when False is specified in LogFileAutoName. Add ".csv" to the string in variables and set it as a file name.

Value	Description
None	Not specified (automatically set)
Variable name	Value of the specified global string variable will be a file name. Only a string variable can be specified.

Default: None

■ LogFileInterval Property

This property sets the sampling period for the files that record force, torque, and the position of the robot during the force guide sequence execution.

	Value (unit: [sec])
Minimum Value	0.002
Maximum value	1

Default: 0.2

■ LogFileMaxTime Property

This property sets the maximum recording time for the files that record force, torque, and the position of the robot during the force guide sequence execution.

If the specified recording time is shorter than the execution time of the force guide sequence, nothing is recorded in the file after the recording time is passed. note that

	Value (unit: [sec])
Minimum Value	60
Maximum value	600

Default: 60

■ PointFile Property

This property sets the point file name that is used during the force guide sequence execution.

If the point file which is not specified by this property is loaded when the force guide sequence starts, an error occurs. This is a property for preventing a wrong operation.

Value	Description
None	Not specified (Any point file whichever loads can be executed without checking it.)
Point file name	An error occurs when the specified point file is not loaded.

Default: None

■ RobotTool Property

This property sets the Tool coordinate system number that is used during the force guide sequence execution.

If the Tool coordinate system number which is not specified by this property is selected when the force guide sequence starts, an error occurs. This is a property for preventing a wrong operation.

Value	Description
0 to 15	An error occurs when the set tool number is not selected.

Default: 0

■ PosCheckEnabled Property

This property sets whether to check the position (X, Y, Z, U, V, W) when starting the force guide sequence.

When specifying True, the force guide sequence starts when the specified conditions are satisfied. If the conditions are not satisfied, the force guide sequence ends as a failure without executing the force guide object. The next SPEL statement of FGRun is executed. When specifying False, the force guide object is executed surely without checking the position.

Value	Description
True	Check the position at the start.
False	You can start at any position without checking the position at the start.

Default: False

■ OrientCheckEnabled Property

This property sets whether to check the arm orientation (Hand, Elbow, Wrist) when starting the force guide sequence.

When specifying True, the force guide sequence starts when it matches the specified arm orientation. If the arm orientations are not matched, the force guide sequence ends as a failure without executing the force guide object. The next SPEL statement of FGRun is executed.

When specifying False, the force guide object is executed surely without checking the arm orientation.

Value	Description
True	Check the position at the start.
False	You can start at any position without checking the position at the start.

Default: False

■ StartCheckPoint Property

This property sets a reference point to check the arm orientation and the position when the force guide sequence starts. It is used when PosCheckEnabled is True.

	Value
Minimum Value	0
Maximum value	999

Default: 0

■ StartPntTolLocal Property

To check the position when the force guide sequence starts, this property sets Local coordinate system number to specify the available range.

It is used when PosCheckEnabled is True. Only the axis direction is used. The origin position in Local coordinate system does not affect.

Value	Description
0 (Base)	Use the Local 0 coordinate system (Base coordinate system).
1 to 15	Use the Local coordinate system of the specified number.

Default: 0 (Base)

■ StartPntTolX Property

To check the position when the force guide sequence starts, this property sets an available range in X direction.

It is used when PosCheckEnabled is True.

When the robot is between the position specified by StartCheckPoint and the position specified by this property in X direction of Local coordinate system specified by StartPntTolLocal, it is determined as conditions are satisfied. Conditions of each direction are determined as AND. Therefore, if one or more of X, Y, Z, or Rot is out of the range, it is determined as failure.

	Value (Unit: [mm])
Minimum Value	0
Maximum value	100

Default: 0

■ StartPntTolY Property

To check the position when the force guide sequence starts, this property sets an available range in Y direction.

It is used when PosCheckEnabled is True.

When the robot is between the position specified by StartCheckPoint and the position specified by this property in Y direction of Local coordinate system specified by StartPntTolLocal, it is determined as conditions are satisfied. Conditions of each direction are determined as AND. Therefore, if one or more of X, Y, Z, or Rot is out of the range, it is determined as failure.

	Value (Unit: [mm])
Minimum Value	0
Maximum value	100

Default: 0

■ StartPntTolZ Property

To check the position when the force guide sequence starts, this property sets an available range in Z direction.

It is used when PosCheckEnabled is True.

When the robot is between the position specified by StartCheckPoint and the position specified by this property in Z direction of Local coordinate system specified by StartPntTolLocal, it is determined as conditions are satisfied. Conditions

of each direction are determined as AND. Therefore, if one or more of X, Y, Z, or Rot is out of the range, it is determined as failure.

	Value (Unit: [mm])
Minimum Value	0
Maximum value	100

Default: 0

■ StartPntTolRot Property

To check the position when the force guide sequence starts, this property sets an available range in the rotational direction. It is used when PosCheckEnabled is True.

If the difference between the current orientation when the force guide sequence starts and the orientation (UVW) specified by StartCheckPoint is within the angle of the value specified by this property, it is determined as conditions are satisfied. Conditions of each direction are determined as AND. Therefore, if one or more of X, Y, Z, or Rot is out of the range, it is determined as failure.

	Value (unit: [deg])
Minimum Value	0
Maximum value	10

Default: 0

4.4.2.1.3 Details on results of general sequence

■ EndStatus Result

It is a result of the execution.

Result will be succeeded when the force guide sequences are executed to the end and the final force guide object is succeeded or AbortSeqOnFail property of the final force guide object is False.

Value	Description
Passed	Force guide sequence is succeeded.
Failed	Force guide sequence is failed.
NoExec	Force guide sequence is not executed.
Aborted	Aborted during the execution of force guide sequence.

■ EndStatusData Result

Detailed information on the executed results.

Failure reasons are described. Return a value from 0 to 7 depending on each bit value (ON:1, OFF:0).

Bit	Description
0	When the force guide object which AbortSeqOnFail is set to True is failed, bit value will be ON.
1	When the position (X, Y, Z, U, V, W) at the start is out of the specified range, bit value will be ON.
2	When the arm orientation (Hand, Elbow, Wrist) at the start is different from the specified one, bit value will be ON.

■ Time Result

This is the time required for execution.

Unit: [sec]

- **LastExecObject Result**
Force guide object name which is executed at the end.
- **EndForces Result**
Force and torque when force guide sequence ends. Acquire values of Fx, Fy, Fz, Tx, Ty, and Tz.
Unit: Fx, Fy, Fz [N] / Tx, Ty, Tz [N · mm]
- **PeakForces Result**
Peak values of force and torque during the force guide object execution. The peak value is a value which absolute value is the largest. Acquire values of Fx, Fy, Fz, Tx, Ty, and Tz.
Unit: Fx, Fy, Fz [N] / Tx, Ty, Tz [N · mm]

4.4.2.2 General force guide object

The following 10 general force guide objects are available.

Category	Object name	Description
Contact	Contact	Move the robot to the specified direction and stop it when contacting with the object.
Follow	Relax	Adjust the position of the robot so that the applied force and torque to the specified axis will be "0".
	FollowMove	While moving the specified trajectory, adjust the position of the robot so that the applied force and torque to the specified axis will be "0".
Align	SurfaceAlign	Align a surface of the grasped workpiece with that of the object.
Probe	PressProbe	Detect a hole or a step on the object while pressing the grasped workpiece.
	ContactProbe	Detect a hole on the object while contacting the grasped workpiece.
Press	Press	Press to the specified axis direction.
	PressMove	Press to the specified axis direction while moving the specified trajectory.
Execution	Decision	Processing branches off depending on the success or failure of the object.
	SPELFunc	Execute a function of the specified SPEL program.

This chapter describes types and properties of each general force guide object, and how to set or adjust the properties. For more details on the settings of the force guide objects, refer to the following section.

Software [Set force guide object\(s\)](#)

4.4.2.2.1 Contact Object

Contact object moves the robot to the specified direction until it contacts with an object such as a workpiece, and stops it when contacting with the object.

This object is used for setting the start position or grasp position of other force guide objects. Even if the workpiece dimension or the grasp position of the workpiece have a margin of error, next motion or the force guide object can be executed stably since the contact position can be detected.

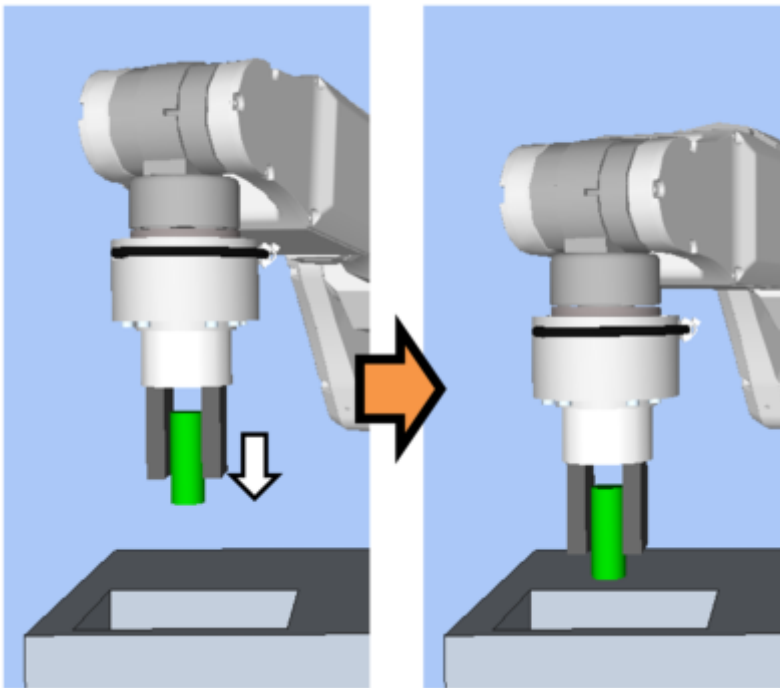

The above figure is an image of a motion by the Contact object. The robot moves to the white arrow direction from the non-contact state and stops when contacting with the object.

The Contact object will be succeeded when the end conditions are satisfied within the specified time. End conditions related to force are always set.

Each condition is as follows:

End condition	Success condition
End conditions related to force	Satisfy either one of the following within the specified time of Timeout:
	When the ContactOrient is Fx, Fy, Fz: The absolute value of the force in the specified direction Exceeds that of ContactForceThresh.
	When the ContactOrient is Tx, Ty, Tz: The absolute value of the torque in the specified direction Exceeds that of ContactTorqueThresh.

4.4.2.2.1 Property setting guidelines for the Contact object

Step 1. Set basic information

Set properties (Name, Description, Enabled, StepID, AbortSeqOnFail) related to the basic information.

Properties	Description, setting guide
Name	Name of the force guide object. Set a particular name.
Description	Description for the force guide object. Describe the operations. Set a character string.

Properties	Description, setting guide
Enabled	Set whether to execute the force guide object.
	True : Normal
	False : When you do not execute the force guide object (e.g., when you execute another force guide object instead).
StepID	StepID during the force guide object execution. Set an ID. StepID is an ID which is recorded in the log data. It helps you to understand which log data support a process. It is applied when AutoStepID of the force guide sequence is False.
AbortSeqOnFail	Set whether to abort or continue the force guide sequence when the force guide object fails.
	True : Normal End a force guide sequence.
	False : Cases where the force guide sequence contains recovery operations in case of failure; cases where the sequence will be able to continue even in the event of a failure.

Step 2. Set I/O processing before starting

Set properties (IOPreprocEnabled, IOPreprocOutputBit, IOPreprocOutputStatus) related to I/O processing before starting force guide object.

Properties	Description, setting guide
IOPreprocEnabled	Set whether to operate the output bit when starting the force guide object. You can operate only one output bit. To operate several output bit, use SPELFunc object.
	False : Normal
	True : You operate the output bit, as when you use or stop a peripheral device.
IOPreprocOutputBit	Set the output bit which is operated when the force guide object starts.
IOPreprocOutputStatus	Set whether to turn the output bit ON or OFF when the force guide object starts. Set the state to be output.

Step 3. Set contact direction and force control functions

Set properties (ContactOrient, ContactFirmnessF, ContactFirmnessT, CFEnabled) related to the contacting direction and force control functions.

Properties	Description, setting guide
ContactOrient	Set a direction to contact. The robot moves or rotates to the specified direction.
ContactFirmnessF ContactFirmnessT	Set a firmness of the force control functions. ContactFirmnessF: When ContactOrient is Fx, Fy, Fz ContactFirmnessT: When ContactOrient is Tx, Ty, Tz
	When setting a large value: The Force Control functions become stronger, but response to changes in force is slow.

Properties	Description, setting guide
	When setting a small value: The Force Control function will become weaker. Response to changes in force is fast; however, vibrations can easily occur.
	When setting a small absolute value: Movement speed of the contact motion will be fast.
CFEnabled	Set whether to continue the force control functions to the next force guide object.
	False : Normal Turn OFF the force control functions once, then execute the next force guide object.
	True : When you want to start the next force guide object, and keep the force constant after contact with the prior object. The next force guide object must maintain the force control in the direction selected in ContactOrient.

You can check the settings of ContactOrient by a simulator. A coordinate system with grayed out except the specified direction is displayed.

However, the robot is displayed based on the current position. When you check the settings, make sure to move the robot to the position where executing the force guide object.

For details on how to check by using simulator, refer to the following manual.

"Epson RC+ 8.0 User's Guide: - Simulator - Description of Functions"

Step 4. Set the end conditions

Set properties (ContactForceThresh, ContactTorqueThresh, Timeout Property) related to the end conditions.

Properties	Description, setting guide
ContactForceThresh ContactTorqueThresh	Set a threshold to determine a contact. Set this to a tolerable value considering the workpiece in use.
	ContactForceThresh: When ContactOrient is Fx, Fy, Fz, Set approx. 3 to 5[N].
	ContactTorqueThresh: When ContactOrient is Tx, Ty, Tz, Set to approximately 3 to 500 [N · mm].
	When setting a large absolute value: Movement speed until the robot makes contact will be fast.
	When the value is too small: Robot may not move.
Timeout	Set a time-out period of a contact motion. It fails if the specified time is passed before contacting.

4.4.2.1.2 Adjustment guideline for Contact object

The following describes the adjustment methods for the Contact object.

- When the contacting force is large:
Decrease the value of ContactForceThresh or ContactTorqueThresh. Or, increase the value of ContactFirmnessF or

ContactFirmnessT.

However, the movement speed will be slow. Please perform proper adjustments for your operations.

- When the force guide object ends before contacting:
If the execution time is short, increase Timeout value.
- When incorrectly determining as "contacted" before contacting:
Contact object determines incorrectly due to the inertia force or noise when moving.
Increase the value of ContactForceThresh or ContactTorqueThresh. However, force and torque when contacting will be large. Please perform proper adjustments for your operations.
Or, increase the value of ContactFirmnessF or ContactFirmnessT. However, the movement speed will be slow. Please perform proper adjustments for your operations.
- When the movement speed until the robot contacts is slow:
Increase the value of ContactForceThresh or ContactTorqueThresh. Or, decrease the value of ContactFirmnessF or ContactFirmnessT.
However, force and torque when contacting will be large, or vibrations may be generated. Please perform proper adjustments for your operations.
- When it takes time to contact:
If the start position of the force guide object is far from a contact position, it takes time since moving distance is long.
Change the start position to a position where is as close as possible to the position to be contacted, but where does not contact with the position.
- When the robot does not move to the contacting direction or move to an opposite direction:
The Force Sensor may not be reset properly. Check the ResetSensor setting of the force guide sequence.
When starting the force guide sequence, the object may start with the contact state. Be sure to start from the non-contact state.
The absolute values of ContactForceThresh or ContactTorqueThresh may be small. Increase the absolute value. However, force and torque when contacting will be large. Please perform proper adjustments for your operations.

4.4.2.2.1.3 Details on properties of the Contact object

- Name Property
This property sets a particular name that is assigned to force guide object. When creating the Contact object, name is assigned automatically. Automatically assigned name is added a number after Contact (e.g. Contact01).
You can change the name. Set up 16 characters at the maximum. Please use alphanumeric characters and underscores [_].
Note: The initial character cannot be a numeric character.
- Description Property
This property sets descriptions about force guide objects. You can set the character string up to 255 characters.
- Enabled Property
This property sets whether to enable force guide objects.
When specifying True, the force guide object is executed. When specifying False, execute the next force guide object without executing the force guide object.
Use this property when you want to save the force guide sequence temporary or try with different parameters by copying the force guide object during the force guide sequence creation.

Value	Description
True	Enable a force guide object.
False	Disable a force guide object.

Default: True

▪ StepID Property

This property sets StepID during the execution of the force guide objects. It is only used when AutoStepID is False.

	Value
Minimum Value	0
Maximum value	32767

Default: Automatically set according to the numbers of the force guide sequence and the force guide object.

▪ AbortSeqOnFail Property

This property sets operations when force guide object fails.

When True is specified: If the force guide object fails, the program ends the force guide sequence and proceeds to the next SPEL statement. When specifying False: If force guide object fails, the program proceeds to the next force guide object without ending the force guide sequence.

Use this property when you want to continue the force guide sequence (e.g. the recovery processes are included in the force guide sequence when the force guide object fails.)

Value	Description
True	Abort the force guide sequence when the force guide object fails.
False	Start the next force guide sequence when the force guide object fails.

Default: True

▪ IOPreprocEnabled Property

This property sets I/O operations when the force guide object starts.

I/O operations are defined by IOPreprocOutputBit Property and IOPreprocOutputStatus Property. Use this property when you want to operate the hands or peripherals before the force guide object execution.

Value	Description
True	Execute I/O operation at the start.
False	I/O operation at the start is not executed.

Default: False

▪ IOPreprocOutputBit Property

This property sets I/O operations (output bit) when the force guide object starts. It is only used when IOPreprocEnabled is True.

	Value
Minimum Value	0
Maximum value	7167

Default: 0

▪ IOPreprocOutputStatus Property

This property sets the output state of I/O operations when the force guide object starts. It is only used when IOPreprocEnabled is True.

Value	Description
Off	Turn OFF the specified output bit. (Set to 0)
On	Turn ON the specified output bit. (Set to 1)

Default: Off

■ ContactOrient Property

This property sets a target contact position as viewed from the start position.

Set the direction in the coordinate system specified by ForceOrient of the force guide sequence. You can select from translation direction (+Fx to -Fz) or rotation direction (+Tx to -Tz). The robot moves to the specified direction and stops when contacting with an object.

Value	Description
+Fx	Move to the positive direction in Fx.
-Fx	Move to the negative direction in Fx.
+Fy	Move to the positive direction in Fy.
-Fy	Move to the negative direction in Fy.
+Fz	Move to the positive direction in Fz.
-Fz	Move to the negative direction in Fz.
+Tx	Move to the positive direction in Tx.
-Tx	Move to the negative direction in Tx.
+Ty	Move to the positive direction in Ty.
-Ty	Move to the negative direction in Ty.
+Tz	Move to the positive direction in Tz.
-Tz	Move to the negative direction in Tz.

Default: +Fz

■ ContactFirmnessF Property

This property sets a firmness of force control functions during execution of the force guide object. It is used when ContactOrient is translation direction (+Fx to -Fz).

When the value of ContactFirmnessF increases, the force control function will become stronger. Response to changes of the force is slow, however, vibration hardly occurs. When the value of ContactFirmnessF decreases, the force control function will become weaker. Response to changes of the force is fast, however, vibration is easy to occur.

	Value
Minimum Value	0.1
Maximum value	200

Default: 10

■ ContactFirmnessT Property

This property sets a firmness of force control functions during execution of the force guide object. It is used when ContactOrient is rotation direction (+Tx to -Tz).

When the value of ContactFirmnessT increases, the force control function will become stronger. Response to changes of the torque is slow, however, vibration hardly occurs. When the value of ContactFirmnessT decreases, the force control function will become weaker. Response to changes of the torque is fast, however, vibration is easy to occur.

	Value
Minimum Value	10
Maximum value	1000000

Default: 3000

■ CFEnabled Property

This property sets whether to continue the force control functions after the force guide object is ended. When the force guide sequence ends even if CFEnabled is True, the force control functions will end.

Value	Description
True	The force control functions continue to the next force guide object even when a force guide object is ended.
False	The force control functions end when the force guide object is ended.

Default: False

■ ContactForceThresh Property

This property sets a threshold of force to determine the contact. It is used when ContactOrient is the translation direction (+Fx to -Fz).

If the threshold set by this property is exceeded during execution of Contact object, the robot recognizes that the robot is contacted and stops the motion. Then, proceed to the next force guide object.

When ContactOrient is in positive direction:

	Value (unit: [N])
Minimum Value	-10
Maximum value	0

Default: -5

When ContactOrient is in negative direction:

	Value (unit: [N])
Minimum Value	0
Maximum value	10

Default: 5

■ ContactTorqueThresh Property

This property sets a threshold of torque to determine the contact. It is used when ContactOrient is rotation direction (+Tx to -Tz). If the threshold set by this property is exceeded during execution of Contact object, the robot recognizes the contact and stops the motion. Then, proceed to the next force guide object.

When ContactOrient is in positive direction:

	Value (unit: [N · mm])
Minimum Value	-1000
Maximum value	0

Default: -200

When ContactOrient is in negative direction:

	Value (unit: [N · mm])
Minimum Value	0

	Value (unit: [N · mm])
Maximum value	1000

Default: 200

- **Timeout Property**

This property sets the time-out period of the force guide object.

If it does not exceed the threshold specified by ContactForceThresh or ContactTorqueThresh even after the time specified by this property has passed, it is determined as contact is failed.

After the determination, end the force guide sequence according to AbortSeqOnFail or proceed to the next force guide object.

	Value (unit: [sec])
Minimum Value	0.1
Maximum value	60

Default: 10

4.4.2.2.1.4 Details on the results of the Contact object

- **EndStatus Result**

It is a result of the execution.

It will be succeeded when satisfying "success conditions" described in

[Contact Object](#)

Value	Description
Passed	Force guide object is succeeded.
Failed	Force guide object is failed.
NoExec	Force guide object is not executed.
Aborted	Aborted during the execution of force guide object.

- **Time Result**

This is the time required for execution.

Unit: [sec]

- **TimedOut Result**

Shows whether the time-out period set in the Timeout property was reached.

Value	Description
True	Reached the time-out period.
False	End before reaching to the time-out period.

- **EndForces Result**

It is force and torque when force guide object ends. Acquire values of Fx, Fy, Fz, Tx, Ty, and Tz.

Unit: Fx, Fy, Fz [N] / Tx, Ty, Tz [N · mm]

- **EndPos Result**

Positions when the force guide object ends. Acquire values of X, Y, Z, U, V, and W.

Unit: X, Y, Z [mm] / U, V, W [deg]

- **AvgForces Result**
 Average values of force and torque during the force guide object execution. Acquire values of Fx, Fy, Fz, Tx, Ty, and Tz.
 Unit: Fx, Fy, Fz [N] / Tx, Ty, Tz [N · mm]
- **PeakForces Result**
 Peak values of force and torque during the force guide object execution. The peak value is a value which absolute value is the largest. Acquire values of Fx, Fy, Fz, Tx, Ty, and Tz.
 Unit: Fx, Fy, Fz [N] / Tx, Ty, Tz [N · mm]
- **ForceCondOK Result**
 Shows whether the end conditions related to force were satisfied.

Value	Description
True	Satisfy the end conditions related to force.
False	The end conditions related to force are not satisfied.
- **TriggeredForces Result**
 It is the force and torque when satisfying the end conditions related to force. Acquire values of Fx, Fy, Fz, Tx, Ty, and Tz.
 Unit: Fx, Fy, Fz [N] / Tx, Ty, Tz [N · mm]
- **TriggeredPos Result**
 Positions when satisfying the end conditions related to force. Acquire values of X, Y, Z, U, V, and W.
 Unit: X, Y, Z [mm] / U, V, W [deg]

4.4.2.2 Relax Object

Relax object moves the robot to a position where the force to the specified direction will be "0".

Use for tasks such as releasing the safe press status after pressing has been performed by a Press object, or removing extra force that was applied during assembly. Also, by combining with the hand motions, this object can follow and grasp. Even if the workpiece dimension or the grasp positions of the workpiece have a margin of error, the robot can grasp the workpiece stably without applying extra force.

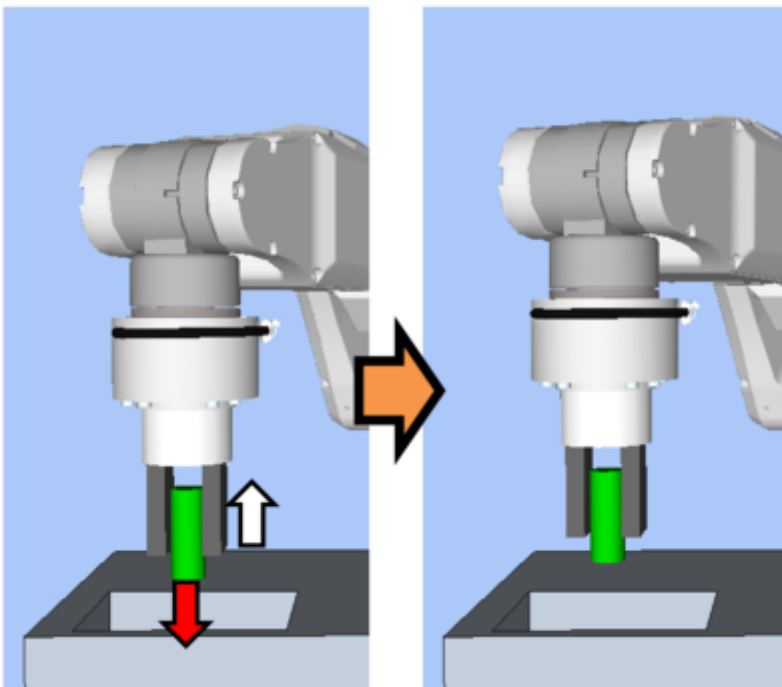

The above figure is the image of a motion by the Relax object. The robot moves from the red arrow state (the robot presses after contacting with an object) to the white arrow direction so that the applied force will be "0".

The Relax object will be succeeded when the end conditions are satisfied within the specified time. The Relax object can use the end conditions related to force and I/O.

Each end condition sets whether to use in ForceCheckEnabled or IOCheckEnabled. If no end condition is set, the object will always be succeeded. When more than one end conditions are set, you can select how to combine the end conditions from AND or OR in EndCheckOperator.

Each condition is as follows:

End condition	Success condition
End conditions related to force	Within the specified time of Timeout, keep all of the following satisfied for the time specified by HoldTimeThresh.
	The axis, which is specified Follow by ControlMode for Fx, Fy, and Fz: Should be within the range of -FollowCheckToIF to +FollowCheckToIF
	The axis, which is specified by Follow by ControlMode for Tx, Ty, and Tz: Should be within the range of -FollowCheckToIT to +FollowCheckToIT
End conditions related to I/O	Input bit specified by IOCheckInputBit should be the state specified by IOCheckInputStatus in the time specified by Timeout.

4.4.2.2.2.1 Property Setting Guideline for Relax Object

Step 1. Set basic information

Set properties (Name, Description, Enabled, StepID, AbortSeqOnFail) related to the basic information.

Properties	Description, setting guide
Name	Name of the force guide object. Set a particular name.
Description	Description for the force guide object. Describe the operations. Set a character string.
Enabled	Set whether to execute the force guide object.
	True : Normal
	False : When you do not execute the force guide object (e.g., when you execute another force guide object instead).
StepID	StepID during the force guide object execution. Set an ID. StepID is an ID which is recorded in the log data. It helps you to understand which log data support a process. It is applied when AutoStepID of the force guide sequence is False.
AbortSeqOnFail	It is whether to abort or continue the force guide sequence when the force guide object fails.
	True : Normal End a force guide sequence.
	False : Cases where the force guide sequence contains recovery operations in case of failure; cases where the sequence will be able to continue even in the event of a failure.

Step 2. Set I/O processing before starting

Set properties (IOPreprocEnabled, IOPreprocOutputBit, IOPreprocOutputStatus) related to I/O processing before starting force guide object.

Properties	Description, setting guide
IOPreprocEnabled	Set whether to operate the output bit when starting the force guide object. You can operate only one output bit. To operate several output bit, use SPELFunc object.
	False : Normal
	True : You operate the output bit, as when you use or stop a peripheral device.
IOPreprocOutputBit	Set the output bit which is operated when the force guide object starts.
IOPreprocOutputStatus	Set whether to turn the output bit ON or OFF when the force guide object starts. Set the state to be output.

Step 3. Set force control functions

Set properties (Fx_ControlMode, ..., Tz_ControlMode, Fx_Firmness, ..., Tz_Firmness, CFEnabled) related to the force control function.

Properties	Description, setting guide
Fx_ControlMode Fy_ControlMode Fz_ControlMode Tx_ControlMode Ty_ControlMode Tz_ControlMode	Set a mode of the force control functions to each direction.
	When specifying Follow: Perform the follow motion by the force control functions.
	When specifying Disabled: Force control functions are disabled.
	Set ControlMode where you want to follow to Follow. You need to set Follow to more than one direction.
Fx_Firmness Fy_Firmness Fz_Firmness Tx_Firmness Ty_Firmness Tz_Firmness	Set a firmness of the force control functions to each direction.
	When setting a large value: The Force Control functions become stronger, but response to changes in force is slow.
	When setting a small value: The Force Control function will become weaker. Response to changes in force is fast; however, vibrations can easily occur.
CFEnabled	Set whether to continue the force control functions to the next force guide object.
	False : Normal Turn OFF the force control functions once, then execute the next force guide object.
	True : When you want to start the next force guide object, and keep the force constant after contact with the prior object. True : The next force guide object must maintain the force control in the directions selected by Follow in each ControlMode.

You can check the settings of ControlMode by a simulator. A coordinate system with grayed out except the enabled direction is displayed. However, the robot is displayed based on the current position. When you check the settings, make sure to move the robot to the position where executing the force guide object. For details on how to check by using simulator, refer to the following manual.

"Epson RC+ 8.0 User's Guide: - Simulator - Description of Functions"

Step 4. Set basic information for end conditions

Set properties (EndCheckOperator, Timeout) related to combinations of end conditions and time-out.

Properties	Description, setting guide
EndCheckOperator	This property sets how to combine the end conditions related to force and I/O. AND : End when both conditions are satisfied. OR: End when one or more conditions is satisfied.
Timeout	Set the time-out duration.
	When the end conditions are not set: Time-out period is the execution time.
	When the end conditions are set: Fails when the end conditions are not satisfied within the specified time.

Step 5. Set end conditions related to force

Set properties (ForceCheckEnabled, FollowCheckToIF, FollowCheckToIT, HoldTimeThresh) related to the end conditions of force.

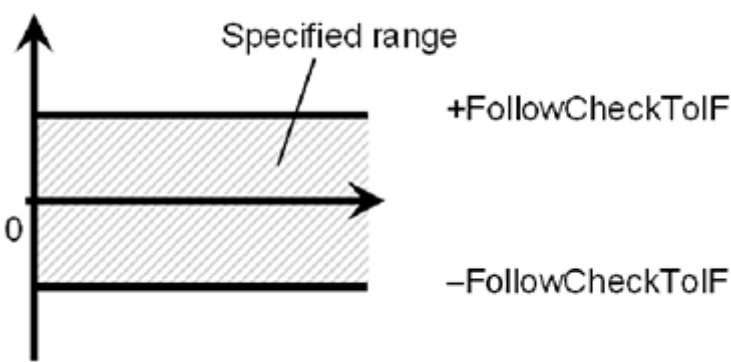
Properties	Description, setting guide
ForceCheckEnabled	This property sets whether to enable the end conditions of force. True : When enabling the end conditions related to force.
FollowCheckToIF FollowCheckToIT	This property sets a range of the translational direction or the rotational direction of the end conditions related to force. FollowCheckToIF: This property indicates the translational direction. FollowCheckToIT: This property indicates the rotational direction.
	the force direction specified by Follow in ControlMode for Fx, Fy, and Fz is Monitor the force in each direction to make sure it is within the range of -FollowCheckToIF to +FollowCheckToIF. the force direction specified by Follow in ControlMode for Tx, Ty, and Tz is Monitor the force in each direction to make sure it is within the range of -FollowCheckToIT to +FollowCheckToIT.
	The following is an image of InsertCheckToIF. 

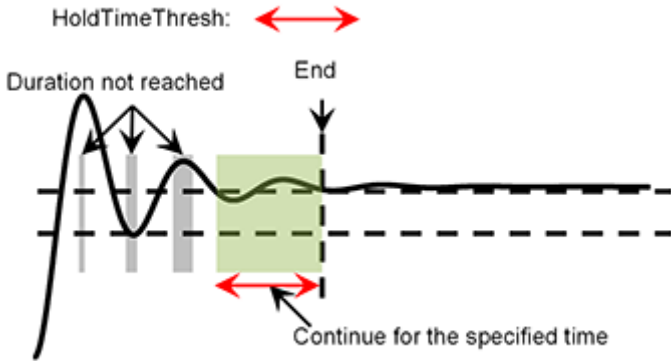
Properties	Description, setting guide
<p>HoldTimeThresh</p>	<p>Set the duration time which is used to determine whether the end conditions have satisfied. As shown below, if the specified condition continues for the time specified by HoldTimeThresh, it is determined as the end conditions are satisfied.</p> 
	<p>Normally, set to "0". Set the time for stabilizing the motion when the results of the next force guide object are unstable. We recommend setting the time according to the actual result which is executed after temporarily disabling the end conditions.</p>

Step 6. Set end conditions related to I/O

Set properties (IOCheckEnabled, IOCheckInputBit, IOCheckInputStatus) related to the end conditions of I/O.

Properties	Description, setting guide
<p>IOCheckEnabled</p>	<p>This property sets whether to enable the end conditions of I/O. True : When the end conditions related to I/O are enabled.</p>
<p>IOCheckInputBit</p>	<p>Set an input bit which is monitored as an end condition.</p>
<p>IOCheckInputStatus</p>	<p>Set a state of the input bit to be an end condition. If the input bit specified by IOCheckInputBit will be the state specified by IOCheckInputStatus, it is determined as the end conditions are satisfied.</p>

4.4.2.2.2 Adjustment guideline for Relax object

The following describes the adjustment methods when using the Relax object.

- When it takes time the force to be "0":
This is a method of adjustment for when the cause of the applied force is not changed. It is an exception when the force is kept applying even the robot moves.
Decrease the Firmness value of each direction. However, the robot motion may be easy to vibrate. Please perform proper adjustments for your operations.
- When the robot motion vibrates:
Increase the Firmness value. However, response of the robot will be slow. Please perform proper adjustments for your operations.
To adjust the Firmness, we recommend changing the value gradually (e.g. increase the value by 10% from its present state).

4.4.2.2.3 Details on properties of the Relax object

▪ Name Property

This property sets a particular name that is assigned to force guide object. When creating the Relax object, name is assigned automatically. Automatically assigned name is added a number after Relax (e.g. Relax01).

You can change the name. Set up 16 characters at the maximum. Please use alphanumeric characters and underscores [_].

Note: The initial character cannot be a numeric character.

▪ Description Property

This property sets descriptions about force guide objects. You can set the character string up to 255 characters.

▪ Enabled Property

This property sets whether to enable force guide objects.

When specifying True, the force guide object is executed. When specifying False, execute the next force guide object without executing the force guide object.

Use this property when you want to save the force guide sequence temporary or try with different parameters by copying the force guide object during the force guide sequence creation.

Value	Description
True	Enable a force guide object.
False	Disable a force guide object.

Default: True

▪ StepID Property

This property sets StepID during the execution of the force guide objects. It is only used when AutoStepID is False.

	Value
Minimum Value	0
Maximum value	32767

Default: Automatically set according to the numbers of the force guide sequence and the force guide object.

▪ AbortSeqOnFail Property

This property sets operations when force guide object fails.

When True is specified: If the force guide object fails, the program ends the force guide sequence and proceeds to the next SPEL statement. When specifying False: If force guide object fails, the program proceeds to the next force guide object without ending the force guide sequence.

Use this property when you want to continue the force guide sequence (e.g. the recovery processes are included in the force guide sequence when the force guide object fails.)

Value	Description
True	Abort the force guide sequence when the force guide object fails.
False	Start the next force guide sequence when the force guide object fails.

Default: True

▪ IOPreprocEnabled Property

This property sets I/O operations when the force guide object starts.

I/O operations are defined by IOPreprocOutputBit Property and IOPreprocOutputStatus Property. Use this property when you want to operate the hands or peripherals before the force guide object execution.

Value	Description
True	Execute I/O operation at the start.
False	I/O operation at the start is not executed.

Default: False

■ IOPreprocOutputBit Property

This property sets I/O operations (output bit) when the force guide object starts. It is only used when IOPreprocEnabled is True.

	Value
Minimum Value	0
Maximum value	7167

Default: 0

■ IOPreprocOutputStatus Property

This property sets the output state of I/O operations when the force guide object starts. It is only used when IOPreprocEnabled is True.

Value	Description
Off	Turn OFF the specified output bit. (Set to 0)
On	Turn ON the specified output bit. (Set to 1)

Default: Off

■ Fx_ControlMode Property

Set the control mode in Fx direction in the coordinate system specified by ForceOrient of the force guide sequence. When specifying Disabled, the force control functions to Fx direction are not executed. When specifying Follow, the force control functions to Fx direction is executed as the follow mode. In the follow mode, the robot moves so that the external force will be "0". Therefore, when the external force is applied, the robot moves to follow it.

Value	Description
Disabled	Disable the force control functions.
Follow	The force control functions are executed to perform the Follow motion.

Default: Disabled

■ Fx_Firmness Property

This property sets a firmness of force control functions in Fx direction during the execution of force guide object. It is used when Fx_ControlMode is Follow.

When the value of Fx_Firmness increases, the force control function in the Fx direction will become stronger. Response to changes in force is slow; however, vibration rarely occurs. When Fx_Firmness decreases, the force control function in the Fx direction will become weaker. Response to changes in force becomes faster; however, vibrations easily occur.

	Value
Minimum Value	0.1
Maximum value	200

Default: 10

■ Fy_ControlMode Property

Set the control mode in Fy direction in the coordinate system specified by ForceOrient of the force guide sequence. When specifying Disabled, the force control functions to Fy direction are not executed. When specifying Follow, the force control functions to Fy direction is executed as the follow mode. In the follow mode, the robot moves so that the external force will be "0". Therefore, when the external force is applied, the robot moves to follow it.

Value	Description
Disabled	Disable the force control functions.
Follow	The force control functions are executed to perform the Follow motion.

Default: Disabled

■ Fy_Firmness Property

This property sets a firmness of force control functions in Fy direction during the execution of force guide object. It is used when Fy_ControlMode is Follow.

When the value of Fy_Firmness increases, the force control function in Fy direction will become stronger. Response to changes of the force is slow, however, vibration hardly occurs. When Fy_Firmness decreases, the force control function in Fy direction will become weaker. Response to changes of the force is fast, however, vibration is easy to occur.

	Value
Minimum Value	0.1
Maximum value	200

Default: 10

■ Fz_ControlMode Properties

Set the control mode in Fz direction in the coordinate system specified by ForceOrient of the force guide sequence.

When specifying Disabled, the force control functions to Fz direction are not executed. When specifying Follow, the force control functions to Fz direction is executed as the follow mode. In the follow mode, the robot moves so that the external force will be "0". Therefore, when the external force is applied, the robot moves to follow it.

Value	Description
Disabled	Disable the force control functions.
Follow	The force control functions are executed to perform the Follow motion.

Default: Disabled

■ Fz_Firmness Property

This property sets a firmness of force control functions in Fz direction during the execution of force guide object.

It is used when Fz_ControlMode is Follow.

When the value of Fz_Firmness increases, the force control function in Fz direction will become stronger. Response to changes in force is slow; however, vibration rarely occurs. When Fz_Firmness decreases, the force control function in Fz direction will become weaker. Response to changes of the force is fast, however, vibration is easy to occur.

	Value
Minimum Value	0.1
Maximum value	200

Default: 10

■ Tx_ControlMode Property

Set the control mode in Tx direction in the coordinate system specified by ForceOrient of the force guide sequence.

When specifying Disabled, the force control functions in the Tx direction are not executed. When specifying Follow, the force control functions to Tx direction is executed as the follow mode. In the follow mode, the robot moves so that the external torque will be "0". Therefore, when the external torque is applied, the robot moves to follow it.

Value	Description
Disabled	Disable the force control functions.
Follow	The force control functions are executed to perform the Follow motion.

Default: Disabled

■ Tx_Firmness Property

This property sets a firmness of force control functions in Tx direction during the execution of force guide object. It is used when Tx_ControlMode is Follow.

When the value of Tx_Firmness increases, the force control function in Tx direction will become stronger. Response to

changes of the torque is slow, however, vibration hardly occurs. When Tx_Firmness decreases, the force control function to Tx direction will become weaker. Response to changes of the torque is fast, however, vibration is easy to occur.

	Value
Minimum Value	10
Maximum value	1000000

Default: 3000

■ Ty_ControlMode Property

Set the control mode in Ty direction in the coordinate system specified by ForceOrient of the force guide sequence. When specifying Disabled, the force control functions in the Ty direction are not executed. When specifying Follow, the force control functions to Ty direction is executed as the follow mode. In the follow mode, the robot moves so that the external torque will be "0". Therefore, when the external torque is applied, the robot moves to follow it.

Value	Description
Disabled	Disable the force control functions.
Follow	The force control functions are executed to perform the Follow motion.

Default: Disabled

■ Ty_Firmness Property

This property sets a firmness of force control functions in Ty direction during the execution of force guide object. It is used when Ty_ControlMode is Follow.

When the value of Ty_Firmness increases, the force control function in Ty direction will become stronger. Response to changes of the torque is slow, however, vibration hardly occurs. When Ty_Firmness decreases, the force control function to Ty direction will become weaker. Response to changes of the torque is fast, however, vibration is easy to occur.

	Value
Minimum Value	10
Maximum value	1000000

Default: 3000

■ Tz_ControlMode Property

Set the control mode in Tz direction in the coordinate system specified by ForceOrient of the force guide sequence. When specifying Disabled, the force control functions to Tz direction are not executed. When specifying Follow, the force control functions to Tz direction is executed as the follow mode. In the follow mode, the robot moves so that the external torque will be "0". Therefore, when the external torque is applied, the robot moves to follow it.

Value	Description
Disabled	Disable the force control functions.
Follow	The force control functions are executed to perform the Follow motion.

Default: Disabled

■ Tz_Firmness Property

This property sets a firmness of force control functions in Tz direction during the execution of force guide object. It is used when Tz_ControlMode is Follow.

When the value of Tz_Firmness increases, the force control function in Tz direction will become stronger. Response to

changes of the torque is slow, however, vibration hardly occurs. When Tz_Firmness decreases, the force control function to Tz direction will become weaker. Response to changes of the torque is fast, however, vibration is easy to occur.

	Value
Minimum Value	10
Maximum value	1000000

Default: 3000

■ CFEnabled Property

This property sets whether to continue the force control functions after the force guide object is ended. When the force guide sequence ends even if CFEnabled is True, the force control functions will end.

Value	Description
True	The force control functions continue to the next force guide object even when a force guide object is ended.
False	The force control functions end when the force guide object is ended.

Default: False

■ EndCheckOperator Property

This property sets the combination conditions when using several end conditions of the force guide object. When specifying AND, if all of the enabled end conditions are satisfied, the force guide object execution ends. The execution is deemed successful, and it proceeds to the next force guide object. When specifying OR, if some of the enabled end conditions are satisfied, the force guide object execution ends. The execution is determined as succeeded and proceed to the next force guide object.

Value	Description
OR	Combine as OR condition.
AND	Combine as AND condition.

Default: AND

■ ForceCheckEnabled Property

For the force guide object end conditions, this property sets conditions related to force.

Value	Description
True	Enable the end conditions related to force.
False	Disable the end conditions related to force.

Default: False

■ FollowCheckToIF Property

This property sets the range of the end conditions related to force. It is used when ForceCheckEnabled is True. It is used in the axis that specified Follow by each ControlMode in Fx, Fy, and Fz, and determined that it is within the range of -FollowCheckToIF to + FollowCheckToIF. If all axes specified Follow are within the range set by either FollowCheckToIF or FollowCheckToIT, it is determined as the end conditions are satisfied.

	Value (unit: [N])
Minimum Value	0.1
Maximum value	10

Default: 1

■ FollowCheckToIT Property

This property sets the range of the end conditions related to force. It is used when ForceCheckEnabled is True. It is used in the axis that specified Follow by each ControlMode in Tx, Ty, and Tz, and determined that it is within the range of -FollowCheckToIF to +FollowCheckToIF. If all axes specified Follow are within the range set by either FollowCheckToIF or FollowCheckToIT, it is determined as the end conditions are satisfied.

	Value (unit: [N · mm])
Minimum Value	If the sequence version is 7.5.1: 1 If the sequence version is 7.4.0: 100
Maximum value	10000

Default: 500

■ HoldTimeThresh Property

This property sets the duration time until the determination of the end conditions related to force. It is used when ForceCheckEnabled is True.

If the state within the range specified by either FollowCheckToIF or FollowCheckToIT continues for the time specified by HoldTimeThresh, it is determined as the end conditions are satisfied.

	Value (unit: [sec])
Minimum Value	0
Maximum value	10

Default: 0

■ IOCheckEnabled Property

This property sets the end conditions of the force guide object related to I/O.

Value	Description
True	Enable the end conditions related to I/O.
False	Disable the end conditions related to I/O.

Default: False

■ IOCheckInputBit Property

This property sets the bit of determination target of the end conditions related to I/O. It is used when IOCheckEnabled is True.

	Value
Minimum Value	0
Maximum value	7167

Default: 0

■ IOCheckInputStatus Property

This property sets the determination conditions of the end conditions related to I/O. It is used when IOCheckEnabled is True.

According to the bit specified by IOCheckInputBit, it is determined as the end conditions are satisfied.

Value	Description
Off	When the input bit is OFF (0), it is determined as the end conditions are satisfied.
On	When the input bit is ON (1), it is determined as the end conditions are satisfied.

Default: Off

■ Timeout Property

This property sets the time-out period of the force guide object.

When it is not satisfied conditions enabled in ForceCheckEnabled or IOCheckEnabled after the time specified by Timeout has passed, it is determined as failure of the Relax object.

After the determination, end the force guide sequence according to AbortSeqOnFail or proceed to the next force guide object.

When ForceCheckEnabled and IOCheckEnabled are False, end the force guide object after the time specified by Timeout is passed. It is determined as succeeded and proceed to the next force guide object.

	Value (unit: [sec])
Minimum Value	0.1
Maximum value	60

Default: 10

4.4.2.2.4 Details on the results of the Relax object

■ EndStatus Result

It is a result of the execution.

It succeeds when the "success conditions" described in 4.2.2.2 Relax Object are satisfied.

Relax Object

Value	Description
Passed	Force guide object is succeeded.
Failed	Force guide object is failed.
NoExec	Force guide object is not executed.
Aborted	Aborted during the execution of force guide object.

■ Time Result

This is the time required for execution.

Unit: [sec]

■ TimedOut Result

Shows whether the time-out period set in the Timeout property was reached.

Value	Description
True	Reached the time-out period.
False	End before reaching to the time-out period.

■ EndForces Result

It is force and torque when force guide object ends. Acquire values of Fx, Fy, Fz, Tx, Ty, and Tz.

Unit: Fx, Fy, Fz[N] / Tx, Ty, Tz [N · mm]

■ EndPos Result

Positions when the force guide object ends. Acquire values of X, Y, Z, U, V, and W.

Unit: X, Y, Z [mm] / U, V, W [deg]

■ AvgForces Result

Average values of force and torque during the force guide object execution. Acquire values of Fx, Fy, Fz, Tx, Ty, and Tz.

Unit: Fx, Fy, Fz [N] / Tx, Ty, Tz [N · mm]

■ PeakForces Result

Peak values of force and torque during the force guide object execution. The peak value is a value which absolute value is

the largest. Acquire values of Fx, Fy, Fz, Tx, Ty, and Tz.

Unit: Fx, Fy, Fz [N] / Tx, Ty, Tz [N · mm]

▪ ForceCondOK Result

Shows whether the end conditions related to force were satisfied.

Value	Description
True	Satisfy the end conditions related to force.
False	The end conditions related to force are not satisfied.

▪ TriggeredForces Result

It is the force and torque when satisfying the end conditions related to force. Acquire values of Fx, Fy, Fz, Tx, Ty, and Tz.

Unit: Fx, Fy, Fz [N] / Tx, Ty, Tz [N · mm]

▪ TriggeredPos Result

Positions when satisfying the end conditions related to force. Acquire values of X, Y, Z, U, V, and W.

Unit: X, Y, Z [mm] / U, V, W [deg]

▪ IOCondOK Result

Shows whether the end conditions related to I/O were satisfied.

Value	Description
True	Satisfy the end conditions related to I/O.
False	The end conditions related to I/O are not satisfied.

4.4.2.2.3 FollowMove Object

FollowMove object moves the robot along with the specified path while following so that the force to the specified direction will be "0".

This object is used for a move of the fixed path of operation targets such as opening/closing the door. In the case of the position control, the operation targets may get damages since extra force is applied if the trajectory moves. However, FollowMove object controls the applied force to be "0". Therefore, the robot can move operation targets without teaching the accurate trajectory.

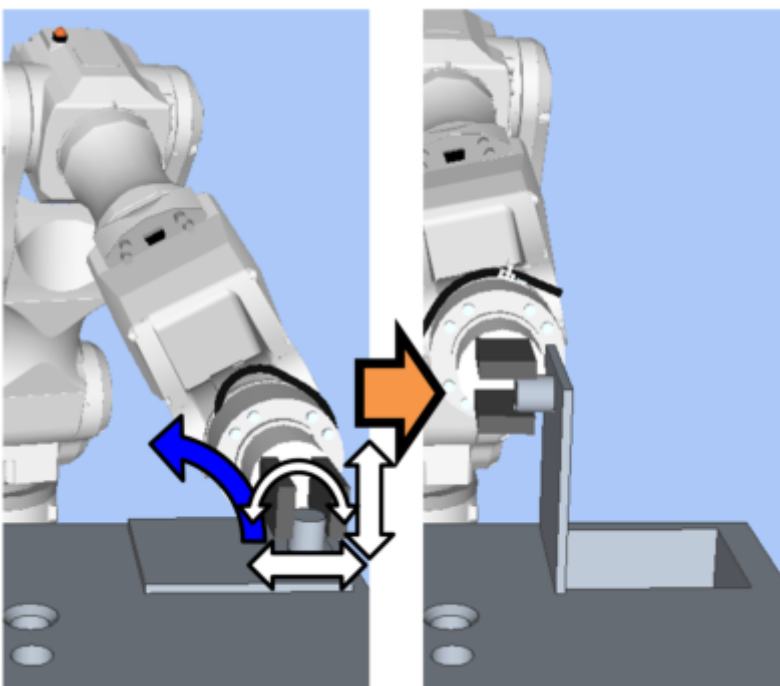

The above figure is an image of a motion by the FollowMove object. The object adjusts the position or the orientation so that the force which is applied to the directions (white arrows) will be "0" while the robot moves along the trajectory (blue arrow).

The FollowMove object will be succeeded when the end conditions are satisfied while the robot moves the specified trajectory. The end conditions related to positions and I/O are available.

Each end condition sets whether to use in PosCheckEnabled or IOCheckEnabled. If no end condition is set, the object will always be succeeded. When several end conditions are set, you can select how to combine the end conditions from AND or OR in EndCheckOperator.

Each condition is as follows:

End condition	Success condition
End conditions related to position	Satisfy either one of the following before moving the robot moves in the specified trajectory:
	When PosCheckType is RobotPlane: Satisfy the state set by PlaneEndCondition for Plane set by PlaneNumber.
	When PosCheckType is RelativePlane: Satisfy the state set by PlaneEndCondition for the relative plane set by PlaneRelativeX, PlaneRelativeY, PlaneRelativeZ, PlaneRelativeOrg, PlaneRelativeOrient, PlaneAxes, PlaneRelativeRobotLocal. Input bit specified by IOCheckInputBit should be the state specified by IOCheckInputStatus before moving the specified trajectory.
End conditions related to I/O	Input bit specified by IOCheckInputBit should be the state specified by IOCheckInputStatus before moving the specified trajectory.

4.4.2.2.3.1 Property setting guidelines for FollowMove object

Step 1. Set basic information

Set properties (Name, Description, Enabled, StepID, AbortSeqOnFail) related to the basic information.

Properties	Description, setting guide
Name	This property sets names of force guide objects. Set a particular name.
Description	This property sets descriptions about force guide objects. Describe the operations. Set a character string.
Enabled	Set whether to execute the force guide object.
	True : Normal
	False : force guide (e.g., when you execute another force guide object instead).
StepID	StepID during the force guide object execution. Set an ID. StepID is an ID which is recorded in the log data. It helps you to understand which log data support a process. It is applied when AutoStepID of the force guide sequence is False.
AbortSeqOnFail	Set whether to abort or continue the force guide sequence when the force guide object fails.
	True : Normal End a force guide sequence.
	False : Cases where the force guide sequence contains recovery operations in case of failure; cases where the sequence will be able to continue even in the event of a failure.

Step 2. Set I/O processing before starting

Set properties (IOPreprocEnabled, IOPreprocOutputBit, IOPreprocOutputStatus) related to I/O processing before starting force guide object.

Properties	Description, setting guide
IOPreprocEnabled	Set whether to operate the output bit when starting the force guide object. You can operate only one output bit. To operate several output bit, use SPELFunc object.
	False : Normal
	True : You operate the output bit, as when you use or stop a peripheral device.
IOPreprocOutputBit	Set the output bit which is operated when the force guide object starts.
IOPreprocOutputStatus	Set whether to turn the output bit ON or OFF when the force guide object starts. Set the state to be output.

Step 3. Set a movement motion

Set properties (MotionTrajectory, AccelS, AccelR, SpeedS, SpeedR, CPEnabled) related to movements.

Properties	Description, setting guide
MotionTrajectory	Set types of trajectory to move.
	Straight : Operates in a straight motion
	Arc : Operates in an arc motion
	MultiStraight : Operates multiple points successively in a straight motion
	MultiStraightCP : Operates multiple points continuously in a straight motion while linking the trajectory
AccelS AccelR	Set an acceleration of the movement.
	AccelS: Translational Acceleration
	AccelR: Rotational rotation acceleration
	Actual acceleration is adjusted by the force control functions.
SpeedS SpeedR	Set the translational velocity of the movement.
	SpeedS: Translational Speed
	SpeedR: Rotational rotation speed
	Actual speed is adjusted by the force control functions.
SpeedRPriority	Sets whether the SpeedR property is prioritized when moving. When the orientation change between points is large relative to the moving distance, operating with the SpeedS property may result in acceleration errors. AutoDistOrientRatio automatically determines whether to use the SpeedR property based on the moving distance between points and the orientation change. Selecting AutoDistOrientRatio is recommended. Select Disabled or Enabled to fix to the SpeedS or SpeedR property.
	Disabled: When constantly using the SpeedS property
	Enabled: When constantly using the SpeedR property

Properties	Description, setting guide
CPEnabled	Set whether to connect the trajectory of the FollowMove object and that of the following force guide object by Path Motion.
	True : Using multiple FollowMove objects to connect complex trajectories during robot operations.

Step 4. Set a destination point

Set properties (DestType, DestPoint, MidPoint, RelativeOrient, RelativeRobotLocal, DestRelativeX, ..., DestRelativeW, MidRelativeX, ..., MidRelativeW) related to trajectories to move.

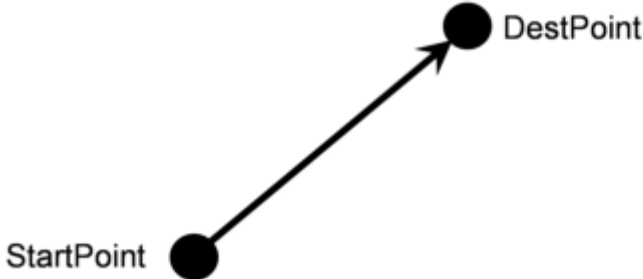
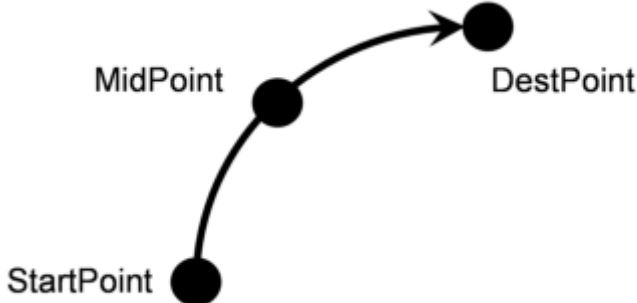
Properties	Description, setting guide
DestType	<p>This property can set how to set a destination point.</p> <p>If you use the force control functions, the robot positions are adjusted by the force. Therefore, we recommend specifying a destination point by a relative movement amount from the positioning point.</p> <p>RobotPoint : When moving to the specified point</p> <p>Relative : When specifying the relative movement amount</p>
DestPoint	<p>Set a point indicating a destination point (DestPoint).</p> <p>When selecting Straight in MotionTrajectory:</p> <p>As shown below, the robot moves in a straight line from the StartPoint of the force guide object to the DestPoint.</p>  <p>The diagram illustrates a straight line trajectory. It starts at a point labeled 'StartPoint' on the left. A solid black arrow points from 'StartPoint' to a point labeled 'DestPoint' on the right, indicating a direct path.</p>
MidPoint	<p>When the MotionTrajectory is Arc, set a point indicating a middle point (MidPoint).</p> <p>As shown below, the robot moves to the DestPoint after passing through the MidPoint.</p>  <p>The diagram illustrates an arc trajectory. It starts at a point labeled 'StartPoint' at the bottom left. A curved black arrow points from 'StartPoint' to a point labeled 'DestPoint' at the top right. A point labeled 'MidPoint' is located on the arc between 'StartPoint' and 'DestPoint', representing the middle point of the trajectory.</p>

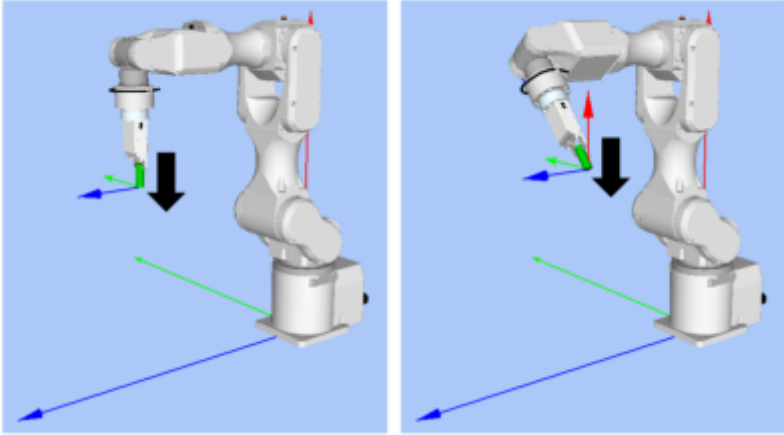
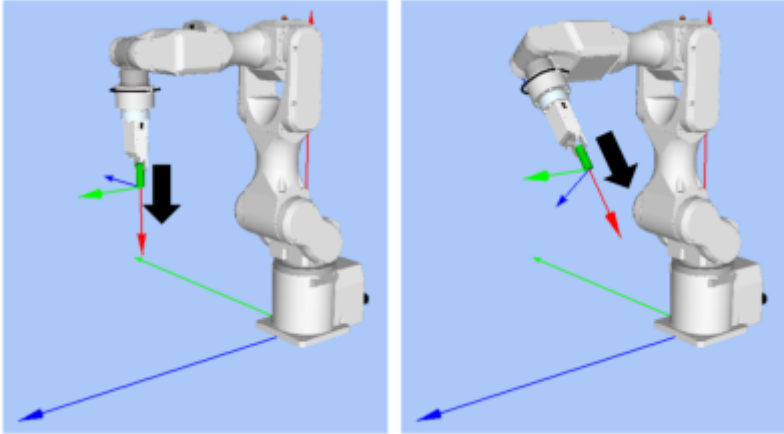
Properties	Description, setting guide
	<p>Set a coordinate system direction which will be a reference of the relative movement.</p> <p>When specifying Base or Local: As viewed from outside, the robot always operates to a defined direction. The following is an example to set Base. When moving to -Z direction, the robot always moves to the vertical-downward (-Z direction in Base coordinate system) even the orientation of end effector changed. (Black arrow is a direction of the robot motion.) If you want to move the robot in a different direction from the Base coordinate system, specify it using the Local coordinate system.</p> 
RelativeOrient	<p>When specifying Tool: Movement direction changes along with the orientation at the start. The following is an example to set Tool. When moving to +Z direction, the moving direction changes depending on the orientation of end effector at the start.</p>  <p>Base, Local: To move the robot to a defined direction as viewed from outside even the robot orientation at the start of the force guide object is changed.</p> <p>Tool: To move to the direction depending on the robot orientation.</p>
RelativeRobotLocal	Set a Local coordinate system number which is used when specifying Local by RelativeOrient.

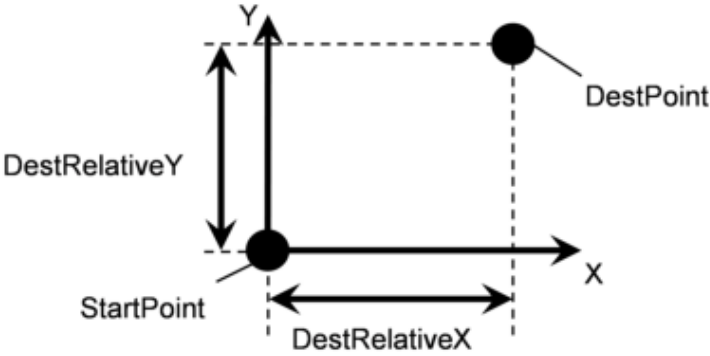
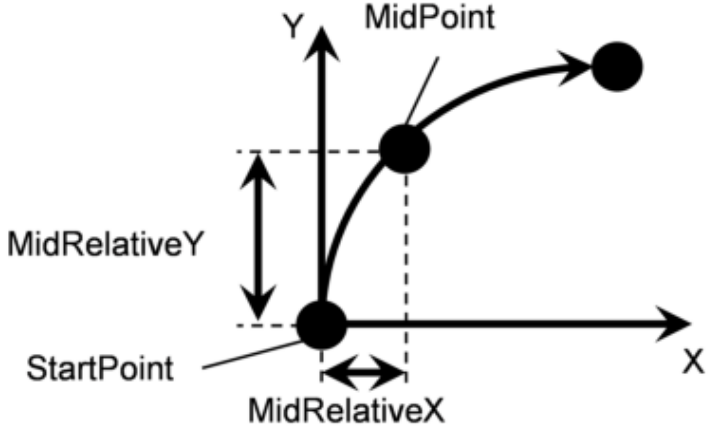
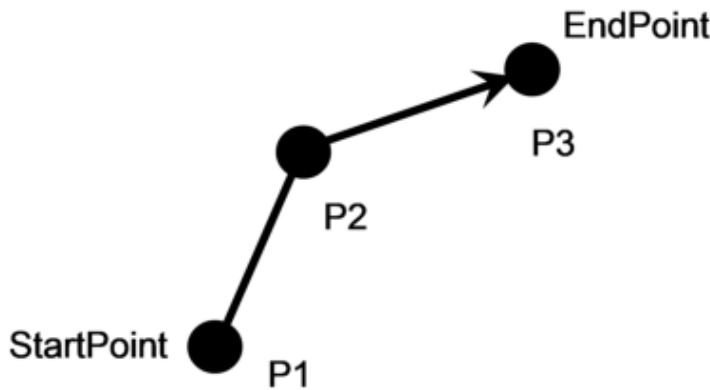
Properties	Description, setting guide
DestRelativeX DestRelativeY DestRelativeZ DestRelativeU DestRelativeV DestRelativeW	<p>Set a relative movement amount to each direction from the StartPoint of the force guide object to the DestPoint.</p> <p>As shown below, set a movement amount in the coordinate system specified by RelativeOrient.</p> 
MidRelativeX MidRelativeY MidRelativeZ MidRelativeU MidRelativeV MidRelativeW	<p>Set a relative movement amount to each direction from the StartPoint of the force guide object to the MidPoint.</p>  <p>As shown below, set a movement amount in the coordinate system specified by RelativeOrient.</p>
StartPoint EndPoint	<p>When MotionTrajectory is MultiStraight or MultiStraighCP, sets the continuous operation start position and end position of the force guide object.</p> <p>As shown in the figure below, when P1 is set for StartPoint and P3 is set for EndPoint, those will be moved continuously in the order of P1, P2, P3.</p> 

Step 5. Set force control functions

Set properties (Fx_ControlMode, ..., Tz_ControlMode, Fx_Firmness, ..., Tz_Firmness, CFEnabled) related to the force control function.

Properties	Description, setting guide
Fx_ControlMode Fy_ControlMode Fz_ControlMode Tx_ControlMode Ty_ControlMode Tz_ControlMode	Set a mode of the force control functions to each direction.
	When specifying Follow: Perform the follow motion by the force control functions.
	When specifying Disabled: Force control functions are disabled.
	Set ControlMode where you want to follow to Follow. You need to set Follow to more than one direction.
Fx_Firmness Fy_Firmness Fz_Firmness Tx_Firmness Ty_Firmness Tz_Firmness	Set a firmness of the force control functions to each direction.
	When setting a large value: The Force Control functions become stronger, but response to changes in force is slow.
	When setting a small value: The Force Control function will become weaker. Response to changes in force is fast; however, vibrations can easily occur.
CFEnabled	Set whether to continue the force control functions to the next force guide object.
	False : Normal Turn OFF the force control functions once, then execute the next force guide object.
	True : When you want to start the next force guide object, and keep the force constant after contact with the prior object. True : The next force guide object must maintain the force control in the directions selected by Follow in each ControlMode.

You can check the settings of ControlMode by a simulator. A coordinate system with grayed out except the enabled direction is displayed. However, the robot is displayed based on the current position. When you check the settings, make sure to move the robot to the position where executing the force guide object. For details on how to check by using simulator, refer to the following manual.

"Epson RC+ 8.0 User's Guide: - Simulator - Description of Functions"

Step 6. Set basic information for end conditions

Set a property (EndCheckOperator) related to combinations of end conditions.

Properties	Description, setting guide
EndCheckOperator	This property sets how to combine the end conditions related to position and I/O. AND : End when both conditions are satisfied. OR: End when one or more conditions is satisfied.

Step 7. Set end conditions about position

Set properties (PosCheckEnabled, PosCheckType, PlaneNumber, PlaneEndCond, PlaneRelativeOrg, PlaneRelativeX, PlaneRelativeY, PlaneRelativeZ, PlaneRelativeOrient, PlaneAxes, PlaneRelativeRobotLocal) related to the end conditions of the positions.

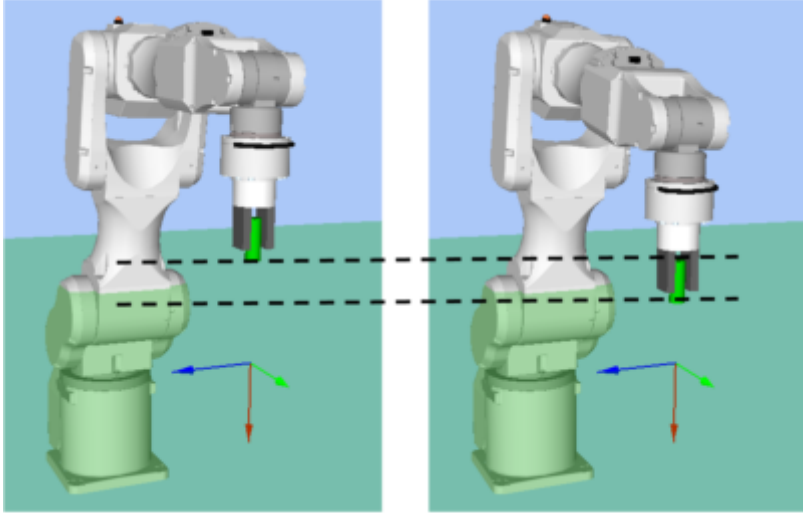
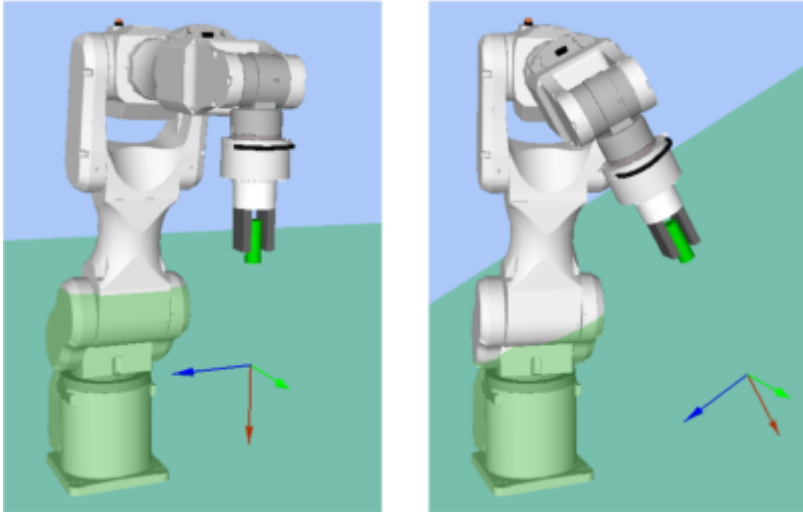
Properties	Description, setting guide
PosCheckEnabled	<p>This property sets whether to enable the end conditions of positions.</p> <p>True : When the end conditions related to position are enabled.</p> <p>False : When the end conditions related to position are disabled.</p>
PosCheckType	<p>Select types of the end conditions related to positions.</p> <p>When selecting RobotPlane: End conditions are based on the set Plane. As shown below, use this property for setting the end conditions based on a defined position regardless of the position of the robot.</p>  <p>When selecting RelativePlane: Every time the force guide sequence is executed, create Plane at a relative position from the current position and set as an end condition of position. As shown below, use this property for changing the end condition positions depending on the position at the start.</p> 
PlaneNumber	<p>Set Plane number which is used for an end condition of positions.</p> <p>When PosCheckType is RobotPlane: End conditions based on the specified Plane number are set.</p>

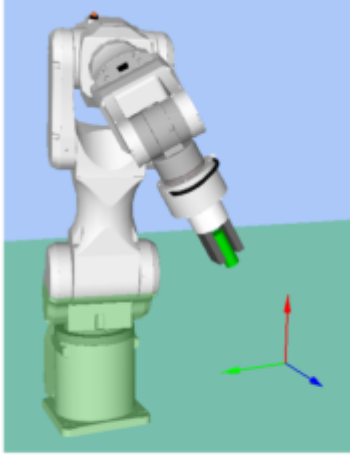
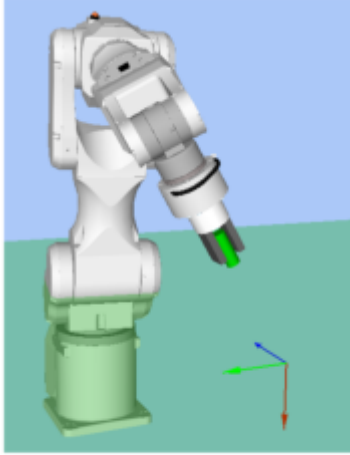
Properties	Description, setting guide
	<p>When PosCheckType is RelativePlane: Every time the force guide sequence is executed, set Plane to the specified number. Set an empty Plane number.</p>
<p>PlaneEndCond</p>	<p>Set the state of the end condition of positions. Set either Inside (inside the Plane) or Outside (outside of the Plane) as an end condition. When the robot will be the specified state, it is determined as the end conditions of the positions are satisfied. Inside the plane: It is in +Z direction of Plane.</p> <div style="display: flex; justify-content: space-around; align-items: center;"> <div style="text-align: center;">  <p>Inside</p> </div> <div style="text-align: center;">  <p>Outside</p> </div> </div>
<p>PlaneRelativeOrg</p>	<p>Set which coordinate system direction is used as a reference when expressing the offset amount to the origin of Plane.</p> <p>The left figure below is an example to set Base. Specify a relative distance based on the Base coordinate system. It is an example that the negative value is set in PlaneRelativeZ.</p> <p>The right figure below is an example to set Tool. Specify a relative distance based on the Tool coordinate system. It is an example that the positive value is set in PlaneRelativeZ.</p> <p>The Local or Tool coordinate systems are used only in that direction and origin position does not affect.</p>

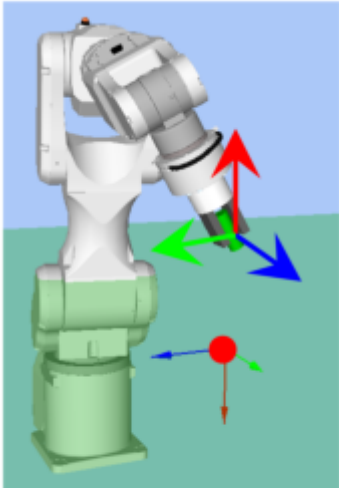
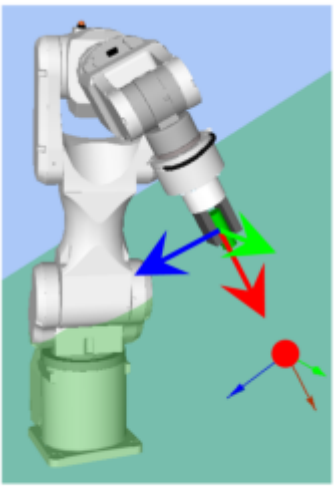
Properties	Description, setting guide
	<div style="display: flex; justify-content: space-around; align-items: center;"> <div style="text-align: center;">  <p>Base</p> </div> <div style="text-align: center;">  <p>Tool</p> </div> </div> <p>To set the position of an end condition in the robot motion direction, normally set the same value as ForceOrient of the force guide sequence.</p>
PlaneRelativeX PlaneRelativeY PlaneRelativeZ	Set offset amount in each direction from the current position to the origin of Plane. Direction will be the coordinate system direction specified by PlaneRelativeOrg.
PlaneRelativeOrient	Set a coordinate system based on the Plane direction.

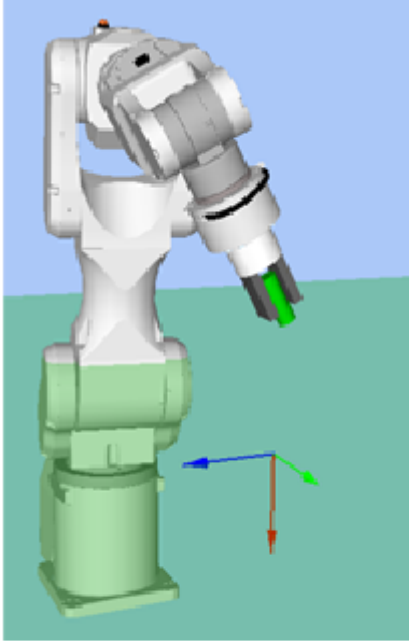
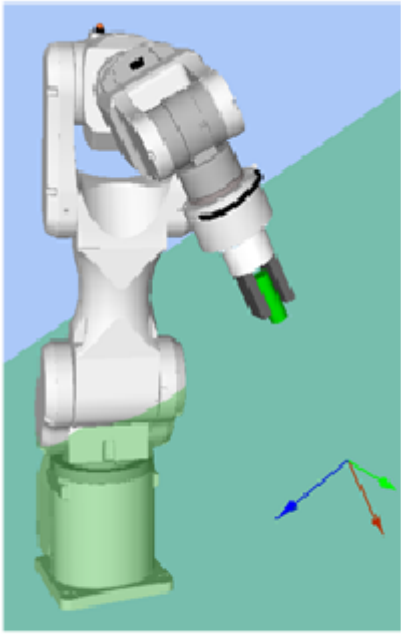
Properties	Description, setting guide
	<p>The left figure below is an example to set Base. Reference direction of the Plane matches the Base coordinate system regardless of the robot orientation at the start of the force guide object.</p> <p>The right figure below is an example to set Tool. Reference direction of the Plane changes along with the robot orientation at the start of the force guide object.</p> <div style="display: flex; justify-content: space-around; align-items: center;"> <div style="text-align: center;">  <p>Ex. to set Base</p> </div> <div style="text-align: center;">  <p>Ex. to set Tool</p> </div> </div>
	<p>Since a plane which is perpendicular to the robot motion direction will be the end conditions, normally set the same value as ForceOrient of the force guide sequence.</p>
<p>PlaneAxes</p>	<p>Set a Plane direction Based on the coordinate system specified by PlaneRelativeOrient, plane is set to a direction set by PlaneAxes. The following figure is an example when Base is set by PlaneRelativeOrient. Left figure: XY is specified by PlaneAxes. Right figure: YZ is specified by PlaneAxes.</p>

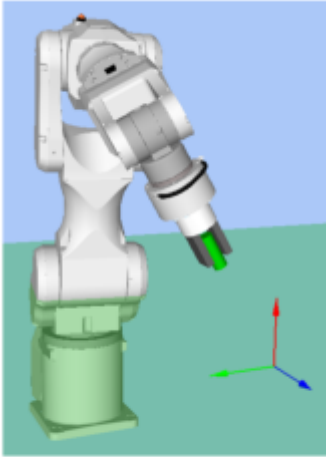
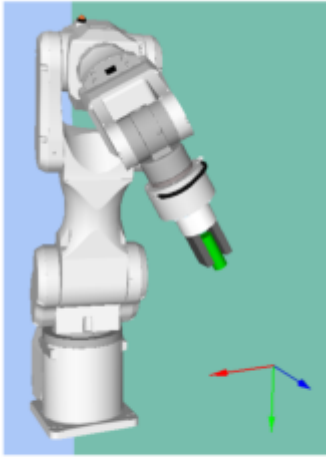
Properties	Description, setting guide
	<div style="display: flex; justify-content: space-around; align-items: center;">   </div> <div style="display: flex; justify-content: space-around; margin-top: 10px;"> XY YZ </div>
	<p>Normally, set Plane which is perpendicular to the robot motion direction.</p>
PlaneRelativeRobotLocal	<p>Set Local coordinate system number which is used when PlaneRelativeOrg or PlaneRelativeOrient are Local. Normally, set a value which is the same as RobotLocal of the force guide sequence.</p>

Step 8. Set end conditions related to I/O

Set properties (IOCheckEnabled, IOCheckInputBit, IOCheckInputStatus) related to the end conditions of I/O.

Properties	Description, setting guide
IOCheckEnabled	<p>This property sets whether to enable the end conditions of I/O. True : When the end conditions related to I/O are enabled.</p>
IOCheckInputBit	<p>Set an input bit which is monitored as an end condition.</p>
IOCheckInputStatus	<p>Set a state of the input bit to be an end condition. If the input bit specified by IOCheckInputBit will be the state specified by IOCheckInputStatus, it is determined as the end conditions are satisfied.</p>

4.4.2.2.3.2 Adjustment guideline for FollowMove object

The following describes the adjustment methods when using the FollowMove object.

- When it takes time the force to be "0":
This is a method of adjustment for when the cause of the applied force is not changed.
It is an exception when the force is kept applying even the robot moves or the robot keeps moving to an object.
Decrease the Firmness value of each direction. However, the robot motion may be easy to vibrate. Please perform proper adjustments for your operations.
- When the robot motion vibrates:
Increase the Firmness value. However, response of the robot will be slow. Please perform proper adjustments for your operations.
To adjust the Firmness, we recommend changing the value gradually (e.g. increase the value by 10% from its present state).

- When the robot does not reach to the destination point:
 If the direction where the force control functions are not enabled is not reached to the destination point, it may be affected by the LimitAccel or LimitSpeed of the force guide sequence. Increase the value.
 Also, in low power mode, it is restricted according to the maximum speed or maximum acceleration of the low power mode even the value of LimitSpeed or LimitAccel is large. Be sure to execute in high power mode.

4.4.2.2.3.3 Details on properties of the FollowMove object

- Name Property**
 This property sets a particular name that is assigned to force guide object. When creating the FollowMove object, name is assigned automatically. Automatically assigned name is added a number after FollowMove (e.g. FollowMove01). You can change the name. Set up 16 characters at the maximum. Please use alphanumeric characters and underscores [_].
 Note: The initial character cannot be a numeric character.
- Description Property**
 This property sets descriptions about force guide objects. You can set the character string up to 255 characters.
- Enabled Property**
 This property sets whether to enable force guide objects.
 When specifying True, the force guide object is executed. When specifying False, execute the next force guide object without executing the force guide object.
 Use this property when you want to save the force guide sequence temporary or try with different parameters by copying the force guide object during the force guide sequence creation.

Value	Description
True	Enable a force guide object.
False	Disable a force guide object.

Default: True

- StepID Property**
 This property sets StepID during the execution of the force guide objects. It is only used when AutoStepID is False.

	Value
Minimum Value	0
Maximum value	32767

Default: Automatically set according to the numbers of the force guide sequence and the force guide object.

- AbortSeqOnFail Property**
 This property sets operations when force guide object fails.
 When True is specified: If the force guide object fails, the program ends the force guide sequence and proceeds to the next SPEL statement.
 When specifying False: If force guide object fails, the program proceeds to the next force guide object without ending the force guide sequence.
 Use this property when you want to continue the force guide sequence (e.g. the recovery processes are included in the force guide sequence when the force guide object fails.)

Value	Description
True	Abort the force guide sequence when the force guide object fails.
False	Start the next force guide sequence when the force guide object fails.

Default: True

- IOPreprocEnabled Property**
 This property sets I/O operations when the force guide object starts.

I/O operations are defined by IOPreprocOutputBit Property and IOPreprocOutputStatus Property. Use this property when you want to operate the hands or peripherals before the force guide object execution.

Value	Description
True	Execute I/O operation at the start.
False	I/O operation at the start is not executed.

Default: False

- IOPreprocOutputBit Property

This property sets I/O operations (output bit) when the force guide object starts. It is only used when IOPreprocEnabled is True.

	Value
Minimum Value	0
Maximum value	7167

Default: 0

- IOPreprocOutputStatus Property

This property sets the output state of I/O operations when the force guide object starts. It is only used when IOPreprocEnabled is True.

Value	Description
Off	Turn OFF (set to 0) the specified output bit.
On	Turn ON (set to 1) the specified output bit.

Default: Off

- MotionTrajectory Property

This property sets trajectory for force guide objects.

Value	Description
Straight	Moves in a straight trajectory.
Arc	Moves in an arcing trajectory.
MultiStraight	Moves multiple points continuously in a straight motion.
MultiStraightCP	Moves multiple points continuously in a straight motion while linking the trajectory.

Default: Straight

- AccelS Property

This property sets acceleration of force guide objects. However, this set value is the acceleration for the set trajectory. The actual acceleration is adjusted by the force control functions.

	Value (unit: [mm/sec ²])
Minimum Value	1
Maximum value	200

Default: 50

■ AccelR Property

This property sets rotation acceleration of force guide objects during the execution. However, this set value is the rotation acceleration for the set trajectory. The actual rotation acceleration is adjusted by the force control functions.

	Value (unit: deg/sec ²)
Minimum Value	1
Maximum value	100

Default: 10

■ SpeedS Property

This property sets speed of force guide objects during the execution. However, this set value is the speed for the set trajectory. The actual speed is adjusted by the force control functions.

	Value (unit: [mm/sec])
Minimum Value	1
Maximum value	200

Default: 50

■ SpeedR Property

This property sets rotation speed of force guide objects during the execution. However, this set value is the rotation speed for the set trajectory. The actual rotation speed is adjusted by the force control functions.

	Value (unit: [deg/sec])
Minimum Value	1
Maximum value	25

Default: 10

■ SpeedRPriority Property

This property sets whether to prioritize tool orientation changes during force guide object execution.

When prioritizing tool orientation changes: The robot moves using the SpeedR property.

When not prioritizing tool orientation changes: The robot moves using the SpeedS property.

- When Disabled is specified:
 - If the moving distance is not "0", the force guide object is executed using the SpeedS property.
 - If the moving distance is "0", the SpeedR property is used.
- When Enabled is specified:
 - If the change in orientation is not "0", the force guide object is executed using the SpeedR property.
 - If the moving distance is "0", the SpeedS property is used.
- When AutoDistOrientRatio is specified:
 - The force guide object is executed by automatically determining whether to prioritize the SpeedR property based on the moving distance and orientation changes.

Value	Description
Disabled	Does not give priority to the tool orientation changes. Prioritizes the SpeedS property
Enabled	Gives priority to the tool orientation changes. Prioritizes the SpeedR property
AutoDistOrientRatio	Automatically determines whether to prioritize tool orientation changes based on the moving distance and orientation changes.

Default: AutoDistOrientRatio

■ CPEnabled Property

Set enable/disable the path motion.

Use this property to synthesize the trajectory for multiple force guide objects with movement.

- When specifying True, path motion is enabled and the program starts the next force guide object when entering into the slowdown zone.
- When specifying False, path motion is disabled and the program starts the next force guide object after the set trajectory ends.

However, if the end conditions are set and achieved, the program pauses once when they are achieved and proceeds to the next force guide object.

Value	Description
True	Enable the path motion.
False	Disable the path motion.

Default: False

■ DestType Property

This property sets the method to specify a destination point of the trajectory.

When specifying RobotPoint, set the destination point on by point. When specifying Relative, set a relative distance (e.g. 10mm from the start point in the X direction).

Value	Description
RobotPoint	Set a point as the destination.
Relative	Set a destination position by relative distance.

Default: RobotPoint

■ DestPoint Property

This property sets the point used as the destination point of the trajectory. It is used when specifying RobotPoint in DestType.

	Value
Minimum Value	0
Maximum value	999

Default: 0

■ MidPoint Property

This property sets the midpoint used for the arc trajectory. It is used when specifying Arc in MotionTrajectory and RobotPoint in DestType.

	Value
Minimum Value	0
Maximum value	999

Default: 0

▪ RelativeOrient Property

This property sets the coordinate system that moves relatively. It is used when specifying Relative in DestType.

Value	Description
Base	Specify a relative distance based on the Base coordinate system.
Local	Specify a relative distance based on the Local coordinate system.
Tool	Specify a relative distance based on the Tool coordinate system.

Default: Tool

▪ RelativeRobotLocal Property

This property sets the number of local coordinate system for the coordinate system that moves relatively. It is used when specifying Relative in DestType and Local in RelativeOrient.

Value	Description
0 (Base)	Use the Local 0 coordinate system (Base coordinate system). It is the same as when specifying Base in RelativeOrient
1 to 15	Use the Local coordinate system of the specified number.

Default: 0 (Base)

▪ DestRelativeX Property

For the destination point, this property sets the moving amount in X direction of coordinate systems specified by RelativeOrient and RelativeRobotLocal.

It is used when specifying Relative in DestType.

	Value (Unit: [mm])
Minimum Value	-2000
Maximum value	2000

Default: 0

▪ DestRelativeY Property

For the destination point, this property sets the moving amount in Y direction of coordinate systems specified by RelativeOrient and RelativeRobotLocal.

It is used when specifying Relative in DestType.

	Value (Unit: [mm])
Minimum Value	-2000
Maximum value	2000

Default: 0

▪ DestRelativeZ Property

For the destination point, this property sets the moving amount in Z direction of coordinate systems specified by RelativeOrient and RelativeRobotLocal.

It is used when specifying Relative in DestType.

	Value (Unit: [mm])
Minimum Value	-2000
Maximum value	2000

Default: 0

▪ DestRelativeU Property

For the destination point, this property sets the rotation amount in U direction of coordinate systems specified by RelativeOrient and RelativeRobotLocal.

It is used when specifying Relative in DestType.

	Value (unit: [deg])
Minimum Value	-360
Maximum value	360

Default: 0

▪ DestRelativeV Property

For the destination point, this property sets the rotation amount in V direction of coordinate systems specified by RelativeOrient and RelativeRobotLocal.

It is used when specifying Relative in DestType.

	Value (unit: [deg])
Minimum Value	-360
Maximum value	360

Default: 0

▪ DestRelativeW Property

For the destination point, this property sets the rotation amount in W direction of coordinate systems specified by RelativeOrient and RelativeRobotLocal.

It is used when specifying Relative in DestType.

	Value (unit: [deg])
Minimum Value	-360
Maximum value	360

Default: 0

▪ MidRelativeX Property

For the mid-point, this property sets the moving amount in X direction of coordinate systems specified by RelativeOrient and RelativeRobotLocal.

It is used when specifying Arc in MotionTrajectory and Relative in DestType.

	Value (Unit: [mm])
Minimum Value	-2000
Maximum value	2000

Default: 0

▪ MidRelativeY Property

For the mid-point, this property sets the moving amount in Y direction of coordinate systems specified by RelativeOrient and RelativeRobotLocal.

It is used when specifying Arc in MotionTrajectory and Relative in DestType.

	Value (Unit: [mm])
Minimum Value	-2000
Maximum value	2000

Default: 0

- **MidRelativeZ Property**

For the mid-point, this property sets the moving amount in Z direction of coordinate systems specified by RelativeOrient and RelativeRobotLocal.

It is used when specifying Arc in MotionTrajectory and Relative in DestType.

	Value (Unit: [mm])
Minimum Value	-2000
Maximum value	2000

Default: 0

- **MidRelativeU Property**

For the mid-point, this property sets the rotating amount in U direction of coordinate systems specified by RelativeOrient and RelativeRobotLocal.

It is used when specifying Arc in MotionTrajectory and Relative in DestType.

	Value (unit: [deg])
Minimum Value	-360
Maximum value	360

Default: 0

- **MidRelativeV Property**

For the mid-point, this property sets the rotating amount in V direction of coordinate systems specified by RelativeOrient and RelativeRobotLocal.

It is used when specifying Arc in MotionTrajectory and Relative in DestType.

	Value (unit: [deg])
Minimum Value	-360
Maximum value	360

Default: 0

- **MidRelativeW Property**

For the mid-point, this property sets the rotating amount in W direction of coordinate systems specified by RelativeOrient and RelativeRobotLocal.

It is used when specifying Arc in MotionTrajectory and Relative in DestType.

	Value (unit: [deg])
Minimum Value	-360
Maximum value	360

Default: 0

- **StartPoint Property**

This property sets the start position of the continuous moving trajectory.

Used when specifying MultiStraight or MultiStraightCP in MotionTrajectory.

	Value
Minimum Value	0
Maximum value	999

Default: 0

▪ EndPoint Property

This property sets the end position of the continuous moving trajectory.
Used when specifying MultiStraight or MultiStraightCP in MotionTrajectory.

	Value
Minimum Value	0
Maximum value	999

Default: 0

▪ Fx_ControlMode Property

Set the control mode in Fx direction in the coordinate system specified by ForceOrient of the force guide sequence.
When specifying Disabled, the force control functions to Fx direction are not executed. When specifying Follow, the force control functions to Fx direction is executed as the follow mode. In the follow mode, the robot moves so that the external force will be "0". Therefore, when the external force is applied, the robot moves to follow it.

Value	Description
Disabled	Disable the force control functions.
Follow	The force control functions are executed to perform the Follow motion.

Default: Disabled

▪ Fx_Firmness Property

This property sets a firmness of force control functions in Fx direction during the execution of force guide object. It is used when Fx_ControlMode is Follow.

When the value of Fx_Firmness increases, the force control function in the Fx direction will become stronger. Response to changes in force is slow; however, vibration rarely occurs. When Fx_Firmness decreases, the force control function in the Fx direction will become weaker. Response to changes in force becomes faster; however, vibrations easily occur.

	Value
Minimum Value	0.1
Maximum value	200

Default: 10

▪ Fy_ControlMode Property

Set the control mode in Fy direction in the coordinate system specified by ForceOrient of the force guide sequence.
When specifying Disabled, the force control functions to Fy direction are not executed.
When specifying Follow, the force control functions to Fy direction is executed as the follow mode. In the follow mode, the robot moves so that the external force will be "0". Therefore, when the external force is applied, the robot moves to follow it.

Value	Description
Disabled	Disable the force control functions.
Follow	The force control functions are executed to perform the Follow motion.

Default: Disabled

▪ Fy_Firmness Property

This property sets a firmness of force control functions in Fy direction during the execution of force guide object. It is used when Fy_ControlMode is Follow.

When the value of Fy_Firmness increases, the force control function in Fy direction will become stronger. Response to changes of the force is slow, however, vibration hardly occurs.

When Fy_Firmness decreases, the force control function in Fy direction will become weaker. Response to changes of the force is fast, however, vibration is easy to occur.

	Value
Minimum Value	0.1
Maximum value	200

Default: 10

■ Fz_ControlMode Properties

Set the control mode in Fz direction in the coordinate system specified by ForceOrient of the force guide sequence.

When specifying Disabled, the force control functions to Fz direction are not executed.

When specifying Follow, the force control functions to Fz direction is executed as the follow mode.

In the follow mode, the robot moves so that the external force will be "0". Therefore, when the external force is applied, the robot moves to follow it.

Value	Description
Disabled	Disable the force control functions.
Follow	The force control functions are executed to perform the Follow motion.

Default: Disabled

■ Fz_Firmness Property

This property sets a firmness of force control functions in Fz direction during the execution of force guide object. It is used when Fz_ControlMode is Follow.

When the value of Fz_Firmness increases, the force control function in Fz direction will become stronger. Response to changes in force is slow; however, vibration rarely occurs.

When Fz_Firmness decreases, the force control function in Fz direction will become weaker. Response to changes of the force is fast, however, vibration is easy to occur.

	Value
Minimum Value	0.1
Maximum value	200

Default: 10

■ Tx_ControlMode Property

Set the control mode in Tx direction in the coordinate system specified by ForceOrient of the force guide sequence.

When specifying Disabled, the force control functions in the Tx direction are not executed.

When specifying Follow, the force control functions to Tx direction is executed as the follow mode.

In the follow mode, the robot moves so that the external torque will be "0". Therefore, when the external torque is applied, the robot moves to follow it.

Value	Description
Disabled	Disable the force control functions.
Follow	The force control functions are executed to perform the Follow motion.

Default: Disabled

■ Tx_Firmness Property

This property sets a firmness of force control functions in Tx direction during the execution of force guide object.

It is used when Tx_ControlMode is Follow.

When the value of Tx_Firmness increases, the force control function in Tx direction will become stronger. Response to changes of the torque is slow, however, vibration hardly occurs.

When Tx_Firmness decreases, the force control function to Tx direction will become weaker. Response to changes of the torque is fast, however, vibration is easy to occur.

	Value
Minimum Value	10
Maximum value	1000000

Default: 3000

■ Ty_ControlMode Property

Set the control mode in Ty direction in the coordinate system specified by ForceOrient of the force guide sequence.

When specifying Disabled, the force control functions in the Ty direction are not executed.

When specifying Follow, the force control functions to Ty direction is executed as the follow mode.

In the follow mode, the robot moves so that the external torque will be "0". Therefore, when the external torque is applied, the robot moves to follow it.

Value	Description
Disabled	Disable the force control functions.
Follow	The force control functions are executed to perform the Follow motion.

Default: Disabled

■ Ty_Firmness Property

This property sets a firmness of force control functions in Ty direction during the execution of force guide object. It is used when Ty_ControlMode is Follow.

When the value of Ty_Firmness increases, the force control function in Ty direction will become stronger. Response to changes of the torque is slow, however, vibration hardly occurs.

When Ty_Firmness decreases, the force control function to Ty direction will become weaker. Response to changes of the torque is fast, however, vibration is easy to occur.

	Value
Minimum Value	10
Maximum value	1000000

Default: 3000

■ Tz_ControlMode Property

Set the control mode in Tz direction in the coordinate system specified by ForceOrient of the force guide sequence.

When specifying Disabled, the force control functions to Tz direction are not executed. When specifying Follow, the force control functions to Tz direction is executed as the follow mode. In the follow mode, the robot moves so that the external torque will be "0". Therefore, when the external torque is applied, the robot moves to follow it.

Value	Description
Disabled	Disable the force control functions.
Follow	The force control functions are executed to perform the Follow motion.

Default: Disabled

■ Tz_Firmness Property

This property sets a firmness of force control functions in Tz direction during the execution of force guide object.

It is used when Tz_ControlMode is Follow.

When the value of Tz_Firmness increases, the force control function in Tz direction will become stronger. Response to changes of the torque is slow, however, vibration hardly occurs.

When Tz_Firmness decreases, the force control function to Tz direction will become weaker. Response to changes of the torque is fast, however, vibration is easy to occur.

	Value
Minimum Value	10
Maximum value	1000000

Default: 3000

■ CFEnabled Property

This property sets whether to continue the force control functions after the force guide object is ended. When the force guide sequence ends even if CFEnabled is True, the force control functions will end.

Value	Description
True	The force control functions continue to the next force guide object even when a force guide object is ended.
False	The force control functions end when the force guide object is ended.

Default: False

■ EndCheckOperator Property

This property sets the combination conditions when using several end conditions of the force guide object.

When specifying AND, if all of the enabled end conditions are satisfied, the force guide object execution ends. The execution is deemed successful, and it proceeds to the next force guide object.

When specifying OR, if all of the enabled end conditions are satisfied, the force guide object execution has been completed and it determined as succeeded.

Value	Description
OR	Combine as OR condition.
AND	Combine as AND condition.

Default: AND

■ PosCheckEnabled Property

This property sets the end conditions of the force guide object related to position.

Value	Description
True	Enable the end conditions related to position.
False	Disable the end conditions related to position.

Default: False

■ PosCheckType Property

For the end conditions related to positions, this property sets whether to use Plane which is defined in advance or set a relative position from the start position of force guide object.

When specifying RobotPlane, set the end conditions by using the defined Plane. When specifying RelativePlane, reset Plane to the relative position from the force guide object start position each time the force guide object is executed.

Value	Description
RobotPlane	Use the defined Plane as the end condition.
RelativePlane	Set Plane to the relative position and use it as the end condition.

Default: RobotPlane

■ PlaneNumber Property

This property sets the Plane number of the plane that will be used for end conditions related to position.

When specifying RobotPlane in the PosCheckType property, Plane of the specified number will not be changed. When specifying Relative in the PosCheckType property, redefine a new Plane to the specified number each time the force guide object is executed. Therefore, note that the original setting will be lost.

	Value
Minimum Value	1
Maximum value	15

Default: 1

■ PlaneEndCond Property

For the end conditions related to positions, this property sets the conditions to be determined as an end.

Value	Description
Outside	Being outside of the Plane is an end condition.
Inside	Being inside of the Plane is an end condition.

Default: Inside

■ PlaneRelativeOrg Property

For the end conditions related to positions, this property specifies which coordinate system is used to set the relative position that sets the Plane. It is used when RelativePlane is specified by PosCheckType.

Value	Description
Base	Specify a relative position based on the Base coordinate system.
Local	Specify a relative position based on the Local coordinate system. Local coordinate system number is specified by PlaneRelativeRobotLocal.
Tool	Specify a relative position based on the Tool coordinate system.

Default: Tool

■ PlaneRelativeX Property

For the end conditions related to positions, this property sets the relative position in X direction to set Plane. It is used when RelativePlane is specified by PosCheckType. X direction follows the coordinate system specified by PlaneRelativeOrg.

	Value (Unit: [mm])
Minimum Value	-2000
Maximum value	2000

Default: 0

■ PlaneRelativeY Property

For the end conditions related to positions, this property sets the relative position in Y direction to set Plane. It is used when RelativePlane is specified by PosCheckType. Y direction follows the coordinate system specified by PlaneRelativeOrg.

	Value (Unit: [mm])
Minimum Value	-2000
Maximum value	2000

Default: 0

■ PlaneRelativeZ Property

For the end conditions related to positions, this property sets the relative position in Z direction to set Plane. It is used when RelativePlane is specified by PosCheckType. Z direction follows the coordinate system specified by PlaneRelativeOrg.

	Value (Unit: [mm])
Minimum Value	-2000
Maximum value	2000

Default: 0

■ PlaneRelativeOrient Property

For the end conditions related to positions, this property sets the coordinate system to set Plane.

It is used when RelativePlane is specified by PosCheckType.

Plane is set on the axis specified by PlaneAxes, according to the coordinate system specified by PlaneRelativeOrient.

When specifying Base, Plane is set on axis specified by PlaneAxes in the Base coordinate system.

When specifying Local, Plane is set on axis specified in PlaneAxes in the Local coordinate system of the number specified by PlaneRelativeRobotLocal.

When specifying Tool, Plane is set on axis specified by PlaneAxes in the Tool coordinate system.

Value	Description
Base	Specify a Plane direction based on the Base coordinate system.
Local	Specify a Plane direction based on the Local coordinate system.
Tool	Specify a Plane direction based on the Tool coordinate system.

Default: Tool

■ PlaneAxes Property

For the end conditions related to positions, this property sets the axis to set Plane.

It is used when RelativePlane is specified by PosCheckType.

Plane is set on the axis specified by PlaneAxes, according to the coordinate system specified by PlaneRelativeOrient.

Value	Description
XY	Set Plane on the XY plane.
YZ	Set Plane on the YZ plane.
XZ	Set Plane on the XZ plane.

Default: XY

■ PlaneRelativeRobotLocal Property

For the end conditions related to positions, this property sets Local coordinate system number that specifies the relative position or direction of Plane.

It is used in either of the following cases: RelativePlane is specified in PosCheckType and Local is specified in PlaneRelativeOrg. RelativePlane is specified in PosCheckType and Local is specified in PlaneRelativeOrient.

Value	Description
0 (Base)	Use the Local 0 coordinate system (Base coordinate system). It is the same as when specifying Base by PlaneRelativeOrg or PlaneRelativeOrient.
1 to 15	Use the Local coordinate system of the specified number.

Default: 0 (Base)

■ IOCheckEnabled Property

This property sets the end conditions of the force guide object related to I/O.

Value	Description
True	Enable the end conditions related to I/O.
False	Disable the end conditions related to I/O.

Default: False

■ IOCheckInputBit Property

This property sets the bit of determination target of the end conditions related to I/O. It is used when IOCheckEnabled is True.

	Value
Minimum Value	0
Maximum value	7167

Default: 0

■ IOCheckInputStatus Property

This property sets the determination conditions of the end conditions related to I/O. It is used when IOCheckEnabled is True.

According to the bit specified by IOCheckInputBit, it is determined as the end conditions are satisfied.

Value	Description
Off	When the input bit is OFF (0), it is determined as the end conditions are satisfied.
On	When the input bit is ON (1), it is determined as the end conditions are satisfied.

Default: Off

4.4.2.2.3.4 Details on results of the FollowMove object

■ EndStatus Result

It is a result of the execution.

It succeeds when the "success conditions" described in 4.2.2.2 Relax Object are satisfied.

FollowMove Object

Value	Description
Passed	Force guide object is succeeded.
Failed	Force guide object is failed.
NoExec	Force guide object is not executed.
Aborted	Aborted during the execution of force guide object.

■ Time Result

This is the time required for execution.

Unit: [sec]

■ EndForces Result

It is force and torque when force guide object ends. Acquire values of Fx, Fy, Fz, Tx, Ty, and Tz.

Unit: Fx, Fy, Fz[N] / Tx, Ty, Tz [N · mm]

- **EndPos Result**
Positions when the force guide object ends. Acquire values of X, Y, Z, U, V, and W.
Unit: X, Y, Z [mm] / U, V, W [deg]
- **AvgForces Result**
Average values of force and torque during the force guide object execution. Acquire values of Fx, Fy, Fz, Tx, Ty, and Tz.
Unit: Fx, Fy, Fz [N] / Tx, Ty, Tz [N · mm]
- **PeakForces Result**
Peak values of force and torque during the force guide object execution. The peak value is a value which absolute value is the largest. Acquire values of Fx, Fy, Fz, Tx, Ty, and Tz.
Unit: Fx, Fy, Fz [N] / Tx, Ty, Tz [N · mm]
- **PosCondOK Result**
Shows whether the end conditions related to position were satisfied.

Value	Description
True	Satisfy the end conditions related to position.
False	The end conditions related to position are not satisfied.

- **IOCondOK Result**
Shows whether the end conditions related to I/O were satisfied.

Value	Description
True	Satisfy the end conditions related to I/O.
False	The end conditions related to I/O are not satisfied.

4.4.2.2.4 SurfaceAlign Object

SurfaceAlign object moves the robot to a position where the torque of the rotation direction will be "0" while the robot presses the workpiece to a specified direction. At this time, the workpiece surface grasped by the robot and the surface of the working desk or the workpiece on the working desk is parallel.

This object is used for positioning during assembly or stable placing of the workpiece. Stable contact status is provided even if the workpiece dimension or the grasped positions of the workpiece have a margin of error.

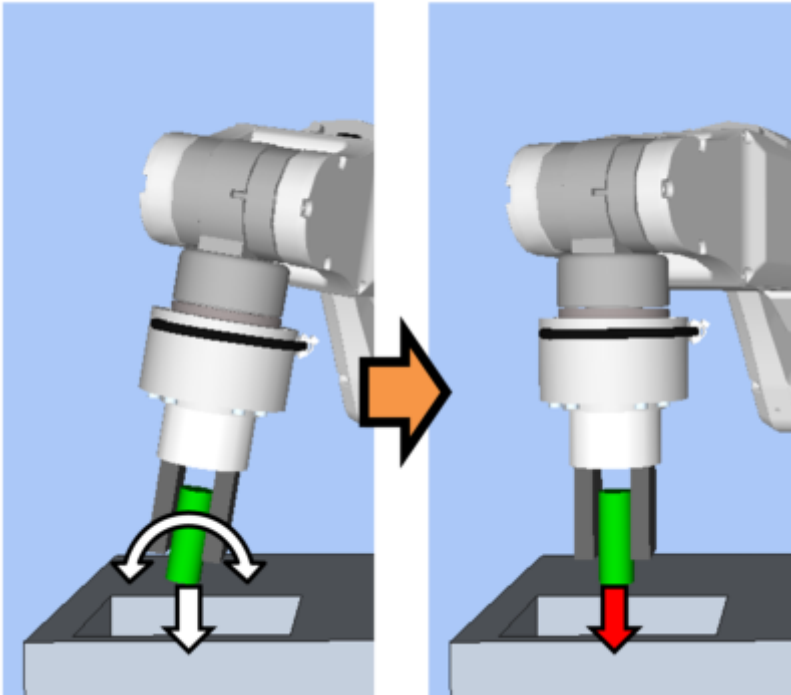

The above figure is an image of a motion by the SurfaceAlign object. As the white arrows show, the robot moves and presses to a downward direction and adjusts the orientation so that the applied torque will be "0".

The SurfaceAlign object will be succeeded when the end conditions are satisfied within the specified time. It can use the end conditions related to force. The end condition sets whether to use in ForceCheckEnabled. If no end condition is set, the object will always be succeeded.

End condition is as follows:

End condition	Success condition
End conditions related to force	Within the specified time of Timeout, keep all of the following satisfied for the time specified by HoldTimeThresh.
	Force direction which is specified by PressOrient The axis should be within the range of PressForce -PressCheckToIF to PressForce +PressCheckToIF.
	Torque in Follow direction specified by FollowOrient: Should be within the range of -FollowCheckToIT to +FollowCheckToIT

4.4.2.2.4.1 Property setting guidelines for the SurfaceAlign object

Step 1. Set basic information

Set properties (Name, Description, Enabled, StepID, AbortSeqOnFail) related to the basic information.

Properties	Description, setting guide
Name	This property sets names of force guide objects. Set a particular name.
Description	This property sets descriptions about force guide objects. Describe the operations. Set a character string.

Properties	Description, setting guide
Enabled	Set whether to execute the force guide object.
	True : Normal
	False : When you do not execute the force guide object (e.g., when you execute another force guide object instead).
StepID	StepID during the force guide object execution. Set an ID. StepID is an ID which is recorded in the log data. It helps you to understand which log data support a process. It is applied when AutoStepID of the force guide sequence is False.
AbortSeqOnFail	Set whether to abort or continue the force guide sequence when the force guide object fails.
	True : Normal End a force guide sequence.
	False : Cases where the force guide sequence contains recovery operations in case of failure; cases where the sequence will be able to continue even in the event of a failure.

Step 2. Set I/O processing before starting

Set properties (IOPreprocEnabled, IOPreprocOutputBit, IOPreprocOutputStatus) related to I/O processing before starting force guide object.

Properties	Description, setting guide
IOPreprocEnabled	Set whether to operate the output bit when starting the force guide object. You can operate only one output bit. To operate several output bit, use SPELFunc object.
	False : Normal
	True : You operate the output bit, as when you use or stop a peripheral device.
IOPreprocOutputBit	Set the output bit which is operated when the force guide object starts.
IOPreprocOutputStatus	Set whether to turn the output bit ON or OFF when the force guide object starts. Set the state to be output.

Step 3. Set force control functions

Set properties (PressOrient, PressForce, PressFirmnessF, AlignOrient, AlignFirmnessT, CFEnabled) related to the force control functions.

Properties	Description, setting guide
PressOrient	This property sets the direction to press. When aligning a surface by pressing the workpiece to be grasped to the object, set a perpendicular direction to the object surface. Set the pressing force.
PressForce	Set the pressing force. When PressOrient is positive direction: Enter a negative value. When PressOrient is negative direction: Enter a positive value. Normally, a value of approximately 3 to 5N is set. However, set a value that is proper for your workpiece. If the value is too small, the robot may not operate. If setting a small value, torque when pressing will be small and it may be difficult to align surfaces.

Properties	Description, setting guide
PressFirmnessF	<p>Set a firmness of the force control functions to pressing direction.</p> <p>When the value increases, the force control function will become stronger and response to changes of the force is slow.</p> <p>When the value decreases, the force control function will become weaker. Response to changes of the force is fast, however, vibration is easy to occur.</p>
AlignOrient	<p>Rotational direction for aligning surfaces.</p> <p>It is changed automatically according to PressOrient. Read only. It cannot be edited.</p> <p>Rotate around two translational directions which are not set by PressOrient.</p> <p>For example, when specifying +Fz or -Fz in PressOrient, Tx and Ty (rotation around Fx and Fy) will be AlignOrient.</p>
AlignFirmnessT	<p>Set a firmness of the force control functions in rotation direction.</p> <p>When the value increases, the force control function will become stronger and response to changes of the force is slow.</p> <p>When the value decreases, the force control function will become weaker. Response to changes of the force is fast, however, vibration is easy to occur.</p>
CFEnabled	<p>Set whether to continue the force control functions to the next force guide object.</p>
	<p>False : Normal</p> <p>Turn OFF the force control functions once, then execute the next force guide object.</p>
	<p>True : After aligning the surface, you want to keep the force constant and start the next force guide object.</p> <p>The next force guide object must maintain the force control in the direction selected in PressOrient and AlignOrient.</p>

Step 4. Set basic information for end conditions

Set property (Timeout) related to time-out.

Properties	Description, setting guide
Timeout	<p>Set the time-out duration.</p>
	<p>When the end conditions are not set:</p> <p>Time-out period is the execution time.</p>
	<p>When the end conditions are set:</p> <p>Fails when the end conditions are not satisfied within the specified time.</p>

Step 5. Set end conditions related to force

Set properties (ForceCheckEnabled, PressCheckToIF, AlignCheckToIT, HoldTimeThresh) related to the end conditions of force.

Properties	Description, setting guide
ForceCheckEnabled	<p>This property sets whether to enable the end conditions of force.</p> <p>True : When enabling the end conditions related to force.</p>

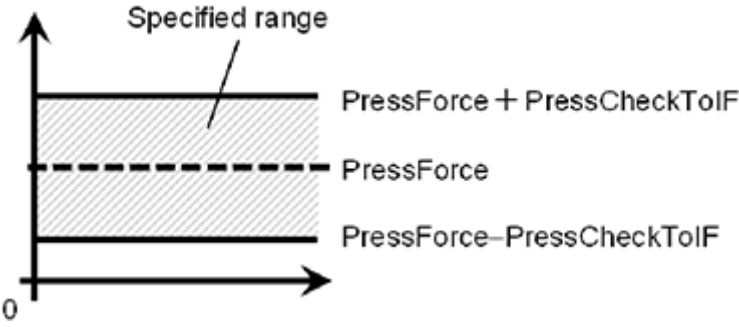
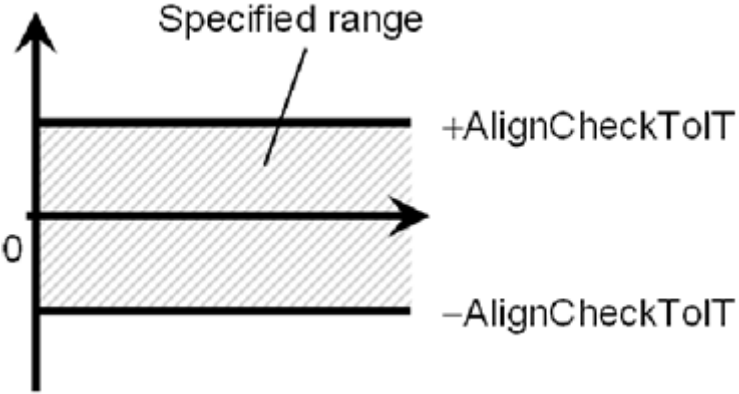
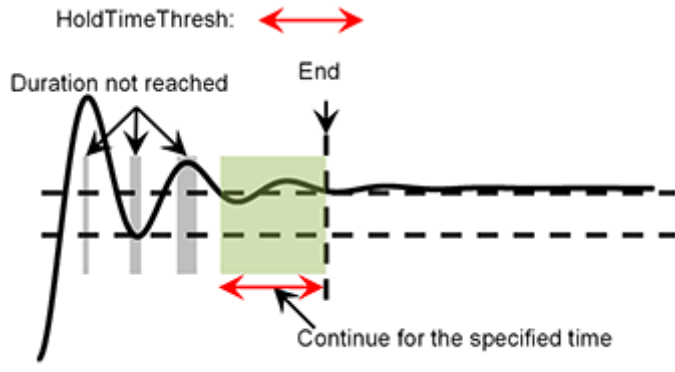
Properties	Description, setting guide
<p>PressCheckToIF</p>	<p>Range of the translational direction of the end conditions related to force. Set a range of the end conditions. Force direction specified by PressOrient: Monitor that the force direction is within the range of PressForce - PressCheckToIF to PressForce + PressCheckToIF.</p> 
<p>AlignCheckToIT</p>	<p>Range of the rotational direction of the end conditions related to force. Set a range of the end conditions. the force in the two directions specified by AlignOrient is Monitor that the force is within the range of - AlignCheckToIT to + AlignCheckToIT.</p> 
<p>HoldTimeThresh</p>	<p>Set the duration time which is used to determine whether the end conditions have satisfied. As shown below, if the specified condition continues for the time specified by HoldTimeThresh, it is determined as the end conditions are satisfied.</p> 

Properties	Description, setting guide
	<p>Normally, set to "0".</p> <p>Set the time for stabilizing the motion when the motion is unstable (e.g. tilt is not aligned after aligning surface).</p> <p>We recommend setting the time according to the actual result which is executed after temporarily disabling the end conditions.</p>

4.4.2.2.4.2 Adjustment guidelines for the SurfaceAlign object

The following describes the adjustment methods when using the SurfaceAlign object.

- When it takes time to align a surface:

Decrease the value of AlignFirmnessT or increase the value of PressForce.

However, decreasing the value of AlignFirmnessT may result in the vibration of the robot motion. Please perform proper adjustments for your operations.

To adjust the AlignFirmnessT, we recommend adjusting the value gradually (e.g. change the value by 10% from its present value).

If increasing the value of PressForce, applied force to workpiece will be large. Set a proper value for your workpiece.

If the contact surface of the workpiece is small, torque when pressing will be small. If the torque is small, rotational speed will be slow depending on the force control functions. Therefore, even adjusting the above two properties, the operation will not be able to finish in the specified time.

- When the robot motion vibrates:

Increase the PressFirmnessF or AlignFirmnessT value.

Adjust Firmness value in the direction where is vibrating. However, response of the robot will be slow. Please perform proper adjustments for your operations.

To adjust the Firmness, we recommend changing the value gradually (e.g. increase the value by 10% from its present state).

- When the robot bounces largely in the pressing direction:

If the robot repeatedly bounces largely in a few seconds, the robot motion may be restricted by LimitAccelS of the force guide sequence.

Also, it likely to happen during the execution in low power mode.

If the robot still bounces even executing in high power mode, increase the value of LimitAccelS. If the robot still bounces, decrease the value of PressFirmnessF.

- When the SurfaceAlign object ends when aligning a surface:

If the specified time is not enough, increase the value of Timeout.

When the end conditions are satisfied even the surface is not aligned, decrease the value of AlignCheckToIT. If it does not work, set HoldTimeThresh.

If the contact surface of the workpiece is small, torque when pressing will be small. Therefore, the object will be within the range specified by AlignCheckToIT even the surfaces are not aligned. In this case, decrease the value of AlignCheckToIT or Disabled the ForceCheckEnabled. Please consider to manage by the execution time specified by Timeout.

4.4.2.2.4.3 Details on properties of the SurfaceAlign object

▪ Name Property

This property sets a particular name that is assigned to force guide object.

When creating the SurfaceAlign object, name is assigned automatically. Automatically assigned name is added a number after SurfAlign (e.g. SurfAlign01).

You can change the name. Set up 16 characters at the maximum. Please use alphanumeric characters and underscores [_].

Note: The initial character cannot be a numeric character.

▪ Description Property

This property sets descriptions about force guide objects. You can set the character string up to 255 characters.

▪ Enabled Property

This property sets whether to enable force guide objects.

When specifying True, the force guide object is executed.

When specifying False, execute the next force guide object without executing the force guide object.

Use this property when you want to save the force guide sequence temporary or try with different parameters by copying the force guide object during the force guide sequence creation.

Value	Description
True	Enable a force guide object.
False	Disable a force guide object.

Default: True

▪ StepID Property

This property sets StepID during the execution of the force guide objects. It is only used when AutoStepID is False.

	Value
Minimum Value	0
Maximum value	32767

Default: Automatically set according to the numbers of the force guide sequence and the force guide object.

▪ AbortSeqOnFail Property

This property sets operations when force guide object fails.

When True is specified: If the force guide object fails, the program ends the force guide sequence and proceeds to the next SPEL statement.

When specifying False: If force guide object fails, the program proceeds to the next force guide object without ending the force guide sequence.

Use this property when you want to continue the force guide sequence (e.g. the recovery processes are included in the force guide sequence when the force guide object fails.)

Value	Description
True	Abort the force guide sequence when the force guide object fails.
False	Start the next force guide sequence when the force guide object fails.

Default: True

▪ IOPreprocEnabled Property

This property sets I/O operations when the force guide object starts.

I/O operations are defined by IOPreprocOutputBit Property and IOPreprocOutputStatus Property.

Use this property when you want to operate the hands or peripherals before the force guide object execution.

Value	Description
True	Execute I/O operation at the start.
False	I/O operation at the start is not executed.

Default: False

■ IOPreprocOutputBit Property

This property sets I/O operations (output bit) when the force guide object starts.

It is only used when IOPreprocEnabled is True.

	Value
Minimum Value	0
Maximum value	7167

Default: 0

■ IOPreprocOutputStatus Property

This property sets the output state of I/O operations when the force guide object starts.

It is only used when IOPreprocEnabled is True.

Value	Description
Off	Turn OFF the specified output bit. (Set to 0)
On	Turn ON the specified output bit. (Set to 1)

Default: Off

■ PressOrient Property

This property sets the direction to press.

Set the direction in the coordinate system specified by ForceOrient of the force guide sequence. You can select from translation direction (+Fx to -Fz). The robot moves to the specified direction and presses.

Value

Description

Value	Description
+Fx	Move to the positive direction in Fx.
-Fx	Move to the negative direction in Fx.
+Fy	Move to the positive direction in Fy.
-Fy	Move to the negative direction in Fy.
+Fz	Move to the positive direction in Fz.
-Fz	Move to the negative direction in Fz.

Default: +Fz

■ PressForce Property

This property sets the force to press.

The robot presses to be the force specified by the PressForce property in PressOrient direction during the execution of SurfaceAlign object. When pressing to positive direction, value will be negative. When pressing to negative direction, value will be positive.

When PressOrient is positive direction:

	Value (unit: [N])
Minimum Value	-50
Maximum value	0

Default: -5

When PressOrient is negative direction:

	Value (unit: [N])
Minimum Value	0
Maximum value	50

Default: 5

■ PressFirmnessF Property

This property sets a gain that indicates a firmness of force control functions to pressing direction during the execution of SurfaceAlign object.

When the value of PressFirmnessF increases, the force control function will become stronger. Response to changes of the force is slow, however, vibration hardly occurs.

When the value of PressFirmnessF decreases, the force control function will become weaker. Response to changes of the force is fast, however, vibration is easy to occur.

	Value
Minimum Value	0.1
Maximum value	200

Default: 10

■ AlignFirmnessT Property

This property sets a gain that indicates a firmness of force control functions to following direction during the execution of SurfaceAlign object.

When AlignFirmnessT increases, the force control function will become stronger. Response to changes of the torque is slow, however, vibration hardly occurs.

When the value of AlignFirmnessT decreases, the force control function will become weaker. Response to changes of the torque is fast, however, vibration is easy to occur.

	Value
Minimum Value	10
Maximum value	1000000

Default: 3000

■ CFEnabled Property

This property sets whether to continue the force control functions after the force guide object is ended.

When the force guide sequence ends even if CFEnabled is True, the force control functions will end.

Value	Description
True	The force control functions continue to the next force guide object even when a force guide object is ended.
False	The force control functions end when the force guide object is ended.

Default: False

■ ForceCheckEnabled Property

For the force guide object end conditions, this property sets conditions related to force.

Value	Description
True	Enable the end conditions related to force.

Value	Description
False	Disable the end conditions related to force.

Default: False

■ PressCheckToIF Property

This property sets the range of the end conditions related to force.

It is used when ForceCheckEnabled is True.

It determines that the force of the direction specified by PressOrient property enters into a range from PressForce - PressCheckToIF to PressForce +PressCheckToIF.

	Value (unit: [N])
Minimum Value	0.1
Maximum value	10

Default: 1

■ AlignCheckToIT Property

This property sets the range of the end conditions related to force. It is used when ForceCheckEnabled is True.

It determines that the force of the direction specified by AlignOrient property enters into a range from -AlignCheckToIT to +AlignCheckToIT.

	Value (unit: [N · mm])
Minimum Value	If the sequence version is 7.5.1: 1 If the sequence version is 7.4.0: 100
Maximum value	10000

Default: 500

■ HoldTimeThresh Property

This property sets the duration time until the determination of the end conditions related to force. It is used when ForceCheckEnabled is True.

If the state within the range specified by either PressCheckToIF or AlignCheckToIT continues for the time specified by HoldTimeThresh, it is determined as the end conditions are satisfied.

	Value (unit: [sec])
Minimum Value	0
Maximum value	10

Default: 0

■ Timeout Property

This property sets the time-out period of the force guide object.

When it is not satisfied conditions enabled in ForceCheckEnabled even if exceeding the time specified by Timeout, it is determined as failure of SurfaceAlign object.

After the determination, end the force guide sequence according to AbortSeqOnFail or proceed to the next force guide object.

When ForceCheckEnabled is False, end the force guide object after time specified by Timeout is passed. Determine as succeeded and proceed to the next force guide object.

	Value (unit: [sec])
Minimum Value	0.1
Maximum value	60

Default: 10

4.4.2.2.4.4 Details on the results of the SurfaceAlign object

▪ EndStatus Result

It is a result of the execution.

It succeeds when the "success conditions" described in 4.2.2.2 Relax Object are satisfied.

SurfaceAlign Object

Value	Description
Passed	Force guide object is succeeded.
Failed	Force guide object is failed.
NoExec	Force guide object is not executed.
Aborted	Aborted during the execution of force guide object.

▪ Time Result

This is the time required for execution.

Unit: [sec]

▪ TimedOut Result

Shows whether the time-out period set in the Timeout property was reached.

Value	Description
True	Reached the time-out period.
False	End before reaching to the time-out period.

▪ EndForces Result

It is force and torque when force guide object ends. Acquire values of Fx, Fy, Fz, Tx, Ty, and Tz.

Unit: Fx, Fy, Fz [N] / Tx, Ty, Tz [N · mm]

▪ EndPos Result

Positions when the force guide object ends. Acquire values of X, Y, Z, U, V, and W.

Unit: X, Y, Z [mm] / U, V, W [deg]

▪ AvgForces Result

Average values of force and torque during the force guide object execution. Acquire values of Fx, Fy, Fz, Tx, Ty, and Tz.

Unit: Fx, Fy, Fz [N] / Tx, Ty, Tz [N · mm]

▪ PeakForces Result

Peak values of force and torque during the force guide object execution. The peak value is a value which absolute value is the largest. Acquire values of Fx, Fy, Fz, Tx, Ty, and Tz.

Unit: Fx, Fy, Fz [N] / Tx, Ty, Tz [N · mm]

▪ ForceCondOK Result

Shows whether the end conditions related to force were satisfied.

Value	Description
True	Satisfy the end conditions related to force.
False	The end conditions related to force are not satisfied.

▪ TriggeredForces Result

It is the force and torque when satisfying the end conditions related to force. Acquire values of Fx, Fy, Fz, Tx, Ty, and Tz.

Unit: Fx, Fy, Fz [N] / Tx, Ty, Tz [N · mm]

- TriggeredPos Result
Positions when satisfying the end conditions related to force. Acquire values of X, Y, Z, U, V, and W.
Unit: X, Y, Z [mm] / U, V, W [deg]

4.4.2.2.5 PressProbe Object

The PressProbe object is a Force Guide object that presses a workpiece grasped by the robot against the work table or a workpiece on the work table while moving the robot along a specified trajectory and stopping when a hole or bump is detected.

This object is used for detection of fitting holes or positioning during assembly. Hole position or a convex shape can be detected stably even if the workpiece dimension or the grasp position of the workpiece have a margin of error. We recommend using the PressProbe object after the Contact object, the SurfaceAlign object, and the Press object.

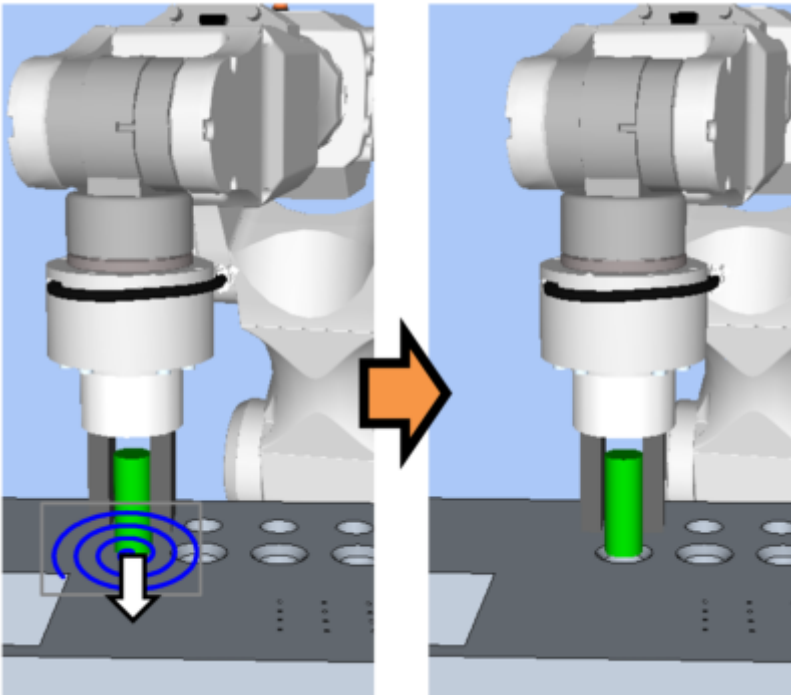

The figure above describes the motion of the PressProbe object. From the contact state, the robot presses to a downward (white arrow) direction and moves along the blue trajectory to probe a hole.

The PressProbe object succeeds if the end conditions are satisfied while the robot is moving along the specified trajectory. The PressProbe object can use the end conditions related to force and position.

Each end condition sets whether to use in ForceCheckEnabled or PosCheckEnabled. More than one end condition is required for the PressProbe object. When several end conditions are set, you can select how to combine the end conditions from AND or OR in EndCheckOperator.

Each condition is as follows:

End condition	Success condition
End conditions related to force	Satisfy either of the following before the robot moves in the specified trajectory:
	When ProbeDetectType is Hole, and PressOrient is the Fx, Fy, and Fz: The force in the specified direction exceeds ProbeDetectThresh.
	When ProbeDetectType is Hole, and PressOrient is -Fx, -Fy, -Fz: Force in the specified direction is less than ProbeDetectThresh.

End condition	Success condition
	When ProbeDetectType is Obstacle: The square root of the sum of the squares of the force that is not specified by Press Orient exceeds ProbeDetectThresh (E.g.: When pressing in the +Fz direction, $\text{sqr}(F_x F_x + F_y F_y)$ exceeds ProbeDetectThresh.)
End conditions related to position	Satisfy either one of the following before moving the robot moves in the specified trajectory:
	When PosCheckType is RobotPlane: Satisfy the state set by PlaneEndCondition for Plane set by PlaneNumber.
	When PosCheckType is RelativePlane: Satisfy the state set by PlaneEndCondition for the relative plane set by PlaneRelativeX, PlaneRelativeY, PlaneRelativeZ, PlaneRelativeOrg, PlaneRelativeOrient, PlaneAxes, PlaneRelativeRobotLocal.

4.4.2.2.5.1 Property setting guidelines for the PressProbe object

Step 1. Set basic information

Set properties (Name, Description, Enabled, StepID, AbortSeqOnFail) related to the basic information.

Properties	Description, setting guide
Name	This property sets names of force guide objects. Set a particular name.
Description	This property sets descriptions about force guide objects. Describe the operations. Set a character string.
Enabled	Set whether to execute the force guide object.
	True : Normal
	False : When you do not execute the force guide object (e.g., when you execute another force guide object instead).
StepID	StepID during the force guide object execution. Set an ID. StepID is an ID which is recorded in the log data. It helps you to understand which log data support a process. It is applied when AutoStepID of the force guide sequence is False.
AbortSeqOnFail	Set whether to abort or continue the force guide sequence when the force guide object fails.
	True : Normal End a force guide sequence.
	False : Cases where the force guide sequence contains recovery operations in case of failure; cases where the sequence will be able to continue even in the event of a failure.

Step 2. Set I/O processing before starting

Set properties (IOPreprocEnabled, IOPreprocOutputBit, IOPreprocOutputStatus) related to I/O processing before starting force guide object.

Properties	Description, setting guide
IOPreprocEnabled	Set whether to operate the output bit when starting the force guide object. You can operate only one output bit. To operate several output bit, use SPELFunc object.

Properties	Description, setting guide
	False : Normal
	True : You operate the output bit, as when you use or stop a peripheral device.
IOPreprocOutputBit	Set the output bit which is operated when the force guide object starts.
IOPreprocOutputStatus	Set whether to turn the output bit ON or OFF when the force guide object starts. Set the state to be output.

Step 3. Set a probe motion

Set properties (ProbeTrajectory, ProbeDetectType, AccelS, SpeedS, SpiralDiam, SpiralPitch, DestRelativeX, DestRelativeY, DestRelativeZ) related to the probe motion.

Properties	Description, setting guide
ProbeTrajectory	Set a trajectory to probe. Select from the following depending on the detection target.
	Spiral trajectory : When a detection target is a hole
	Straight line trajectory : When a detection target is an obstacle
	Straight : When it is clear that the target is on the specified straight line.
	Spiral : When the target is not on the specified straight line.
ProbeDetectType	Set a target to be detected. You can select a hole and an obstacle. The obstacle is a convex shape on the plane to probe.
AccelS	Set the translational acceleration of the movement. Actual translational acceleration is adjusted by the force control functions.
SpeedS	Set the translational velocity of the movement. Actual translational velocity is adjusted by the force control functions.
SpiralDiam SpiralPitch	Set a diameter and pitch of the spiral trajectory.

Properties	Description, setting guide
	<div data-bbox="379 226 1007 954" data-label="Image"> </div> <div data-bbox="341 999 1396 1144" data-label="Text"> <p>SpiralDiam : Set a value which is the maximum value of the distance from the start point to the detection target (positional variations are included) plus an added margin. Example: Value: 1.1 times larger than the maximum value</p> </div> <div data-bbox="341 1173 1294 1279" data-label="Text"> <p>SpiralPitch : Set a value which does not pass through the detection target. When detecting a hole, set a smaller value than the minimum interval between the holes.</p> </div>
<p>DestRelativeX DestRelativeY DestRelativeZ</p>	<p>Set a relative movement amount to each direction from the start point of the force guide object to the destination point. As shown below, set the movement amount in the coordinate system specified by ForceOrient of the force guide sequence.</p> <div data-bbox="363 1487 1428 1973" data-label="Diagram"> </div>

Step 4. Set force control functions

Set properties (PressOrient, PressForce, PressFirmnessF, CFEnabled) related to the force control functions.

Properties	Description, setting guide
PressOrient	Direction to press. Set a vertical direction to a probe plane. To probe a detection target, move the robot along with the trajectory specified at Step.3 while pressing to the specified direction.
PressForce	Set the pressing force. When PressOrient is positive direction: Enter a negative value. When PressOrient is negative direction: Enter a positive value. Normally, a value of approximately 3 to 5N is set. However, set a value that is proper for your workpiece. If the value is too small, the robot may move away from the probe plane.
PressFirmnessF	Set a firmness of the force control functions to pressing direction. When the value increases, the force control function will become stronger and response to changes of the force is slow. When the value decreases, the force control function will become weaker. Response to changes of the force is fast, however, vibration is easy to occur.
CFEnabled	Set whether to continue the force control functions to the next force guide object.
	False : Normal Turn OFF the force control functions once, then execute the next force guide object.
	True : When you want to start the next force guide object while maintaining a steady force even after the target is detected: The next force guide object must maintain the force control in the direction selected in ContactOrient.

Step 5. Set basic information for end conditions

Set a property (EndCheckOperator) related to combinations of end conditions.

Properties	Description, setting guide
EndCheckOperator	This property sets how to combine the end conditions related to force and position. AND : End when both conditions are satisfied. OR: End when one or more conditions is satisfied.

Step 6. Set end conditions related to force

Set properties (ForceCheckEnabled, ProbeDetectThresh) related to the end conditions of force.

Properties	Description, setting guide
ForceCheckEnabled	This property sets whether to enable the end conditions of force. You need to enable ForceCheckEnabled and/or PosCheckEnabled in the PressProbe object.
	True : When enabling the end conditions related to force. Select when ProbeDetectType is Obstacle. When ProbeDetectType is Hole, select True if necessary.

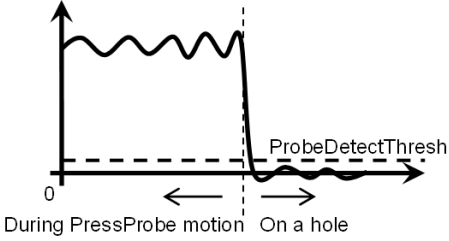
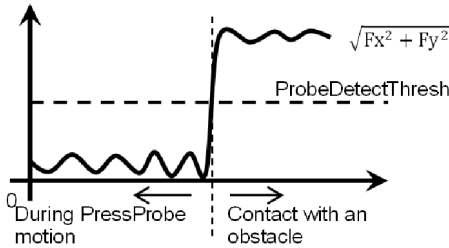
Properties	Description, setting guide
ProbeDetectThresh	<p>Set a threshold to determine that the target is detected.</p>
	<p>When ProbeDetectType is Hole: Threshold for the direction specified by PressOrient When PressOrient is a positive direction: Set a negative value. When PressOrient is a negative direction: Set a positive value. The following graph is an example to set a negative direction by PressOrient. Force is applied while the robot presses on the probe plane. However, when the robot moves to the position of a hole, it will enter the non-contact state, so the absolute value of the force will become smaller.</p> 
	<p>When ProbeDetectType is Obstacle: Threshold for the square root of the sum of the squares to the two directions which are not specified by PressOrient Set a positive value. The following graph is an example to set -Fz direction by PressOrient. When probing during motion in the Fx direction, a small force will be detected due to friction with the probe plane. If the robot makes contact with an obstacle, a large force will be detected.</p> 
	<p>When detecting a hole: Normally, set to "0".</p>
	<p>When the force will not be "0" even if the robot moves above the hole: Set a value which is small enough for the absolute value of the force during the probe motion.</p>
	<p>When detecting an obstacle: Set a value which is large enough for the force during the probe motion and smaller than the force when contacting.</p>

Step 7. Set end conditions about position

Set properties (PosCheckEnabled, PosCheckType, PlaneNumber, PlaneEndCond, PlaneRelativeOrg, PlaneRelativeX, PlaneRelativeY, PlaneRelativeZ, PlaneRelativeOrient, PlaneAxes, PlaneRelativeRobotLocal) related to the end conditions of the positions.

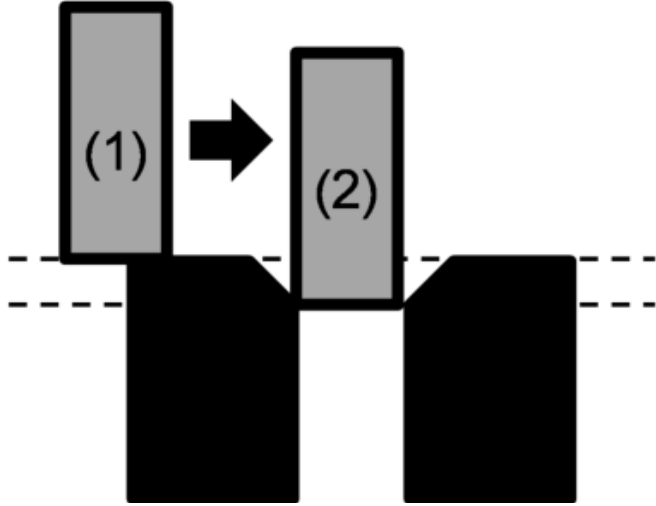
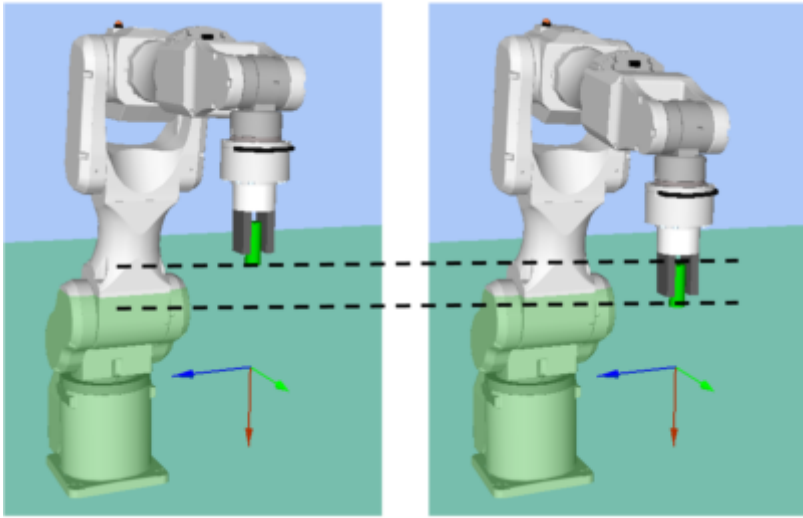
Properties	Description, setting guide
PosCheckEnabled	<p>This property sets whether to enable the end conditions of positions. You need to enable ForceCheckEnabled and/or PosCheckEnabled in the PressProbe object. This property may be used when ProbeDetectType is Hole. Normally, this property is not used when ProbeDetectType is Obstacle. As shown below, to detect a hole, you can make it an end condition that the robot moves to the hole direction by a certain distance from the probe plane.</p>  <p>True : When the end conditions related to position are enabled.</p>
PosCheckType	<p>Select types of the end conditions related to positions.</p> <p>When selecting RobotPlane: End conditions are based on the set Plane. As shown below, use this property for setting the end conditions based on a defined position regardless of the position of the robot.</p>  <p>When selecting RelativePlane: Every time the force guide sequence is executed, create Plane at a relative position from the current position and set as an end condition of position. As shown below, use this property for changing the end condition positions depending on the position at the start.</p>

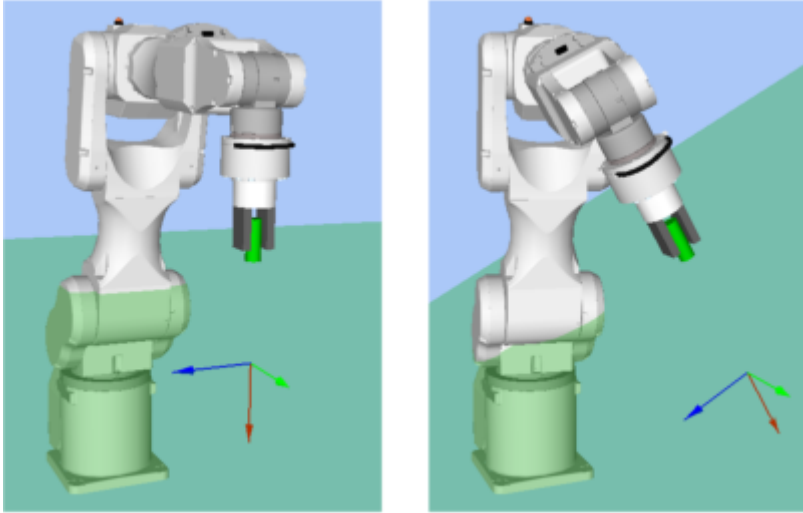
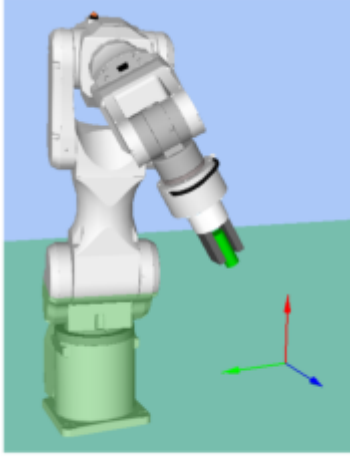
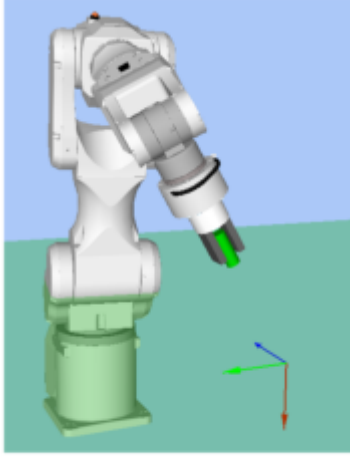
Properties	Description, setting guide
	<div style="display: flex; justify-content: space-around;">  </div> <p>In PressProbe, we recommend using RelativePlane.</p>
PlaneNumber	Set Plane number which is used for an end condition of positions.
	When PosCheckType is RobotPlane: End conditions based on the specified Plane number are set.
	When PosCheckType is RelativePlane: Every time the force guide sequence is executed, reset the Plane to the specified number. Set an empty Plane number.
PlaneEndCond	<p>Set the state of the end condition of positions. Set either Inside (inside the Plane) or Outside (outside of the Plane) as an end condition. When the robot will be the specified state, it is determined as the end conditions of the positions are satisfied.</p> <p>Inside the plane: It is in +Z direction of Plane.</p> <div style="display: flex; justify-content: space-around; align-items: center;"> <div style="text-align: center;">  <p>Inside</p> </div> <div style="text-align: center;">  <p>Outside</p> </div> </div>

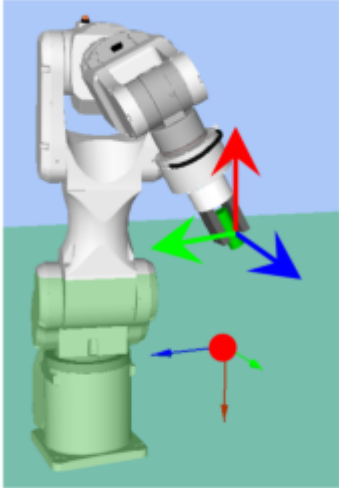
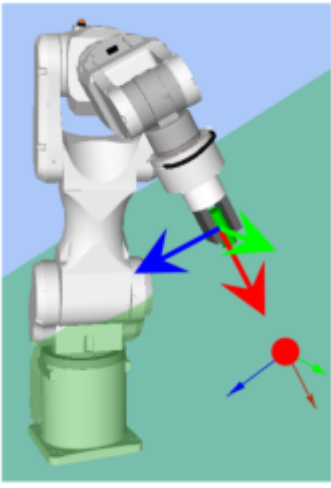
Properties	Description, setting guide
PlaneRelativeOrg	<p>Set which coordinate system direction is used as a reference when expressing the offset amount to the origin of Plane.</p> <p>The left figure below is an example to set Base. Specify a relative distance based on the Base coordinate system. It is an example that the negative value is set in PlaneRelativeZ. The right figure below is an example to set Tool. Specify a relative distance based on the Tool coordinate system. It is an example that the positive value is set in PlaneRelativeZ.</p> <div style="display: flex; justify-content: space-around; align-items: center;">   </div> <div style="display: flex; justify-content: space-around; margin-top: 10px;"> Base Tool </div> <p>The Local or Tool coordinate systems are used only in that direction and origin position does not affect. To set the position of an end condition in the robot motion direction, normally set the same value as ForceOrient of the force guide sequence.</p>
PlaneRelativeX PlaneRelativeY PlaneRelativeZ	<p>Set offset amount in each direction from the current position to the origin of Plane. Direction will be the coordinate system direction specified by PlaneRelativeOrg.</p>
PlaneRelativeOrient	<p>Set a coordinate system based on the Plane direction. The left figure below is an example to set Base. Reference direction of the Plane matches the Base coordinate system regardless of the robot orientation at the start of the force guide object. The right figure below is an example to set Tool. Reference direction of the Plane changes along with the robot orientation at the start of the force guide object.</p>

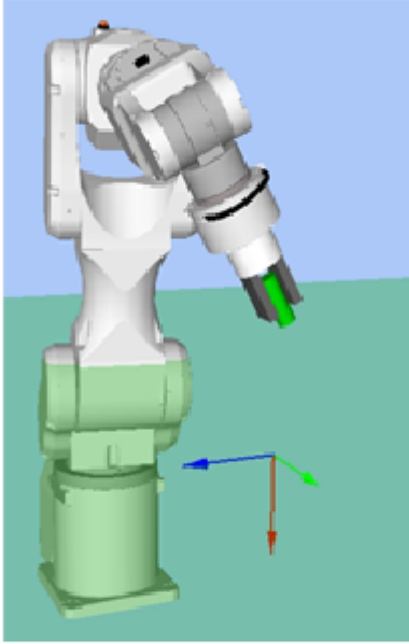
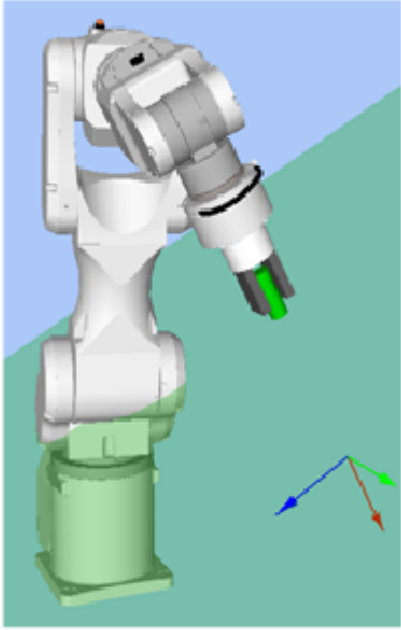
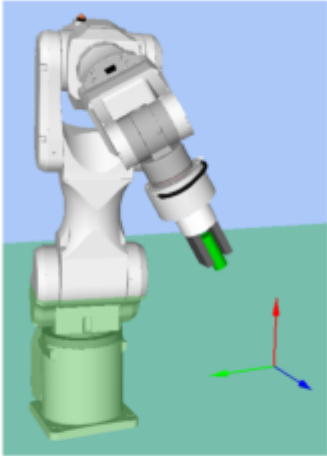
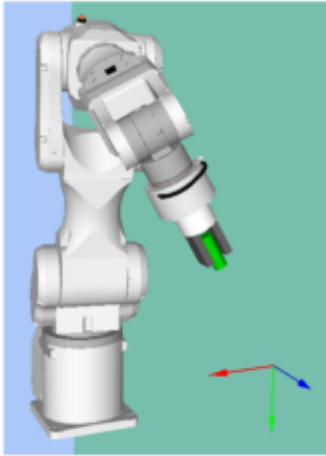
Properties	Description, setting guide
	<div style="display: flex; justify-content: space-around; align-items: center;"> <div style="text-align: center;">  <p>Ex. to set Base</p> </div> <div style="text-align: center;">  <p>Ex. to set Tool</p> </div> </div> <p>Since a plane which is perpendicular to the robot motion direction will set as the end condition, normally set the same value as ForceOrient of the force guide sequence.</p>
PlaneAxes	<p>Set a Plane direction Based on the coordinate system specified by PlaneRelativeOrient, plane is set to a direction set by PlaneAxes. The following figure is an example when Base is set by PlaneRelativeOrient. Left figure: XY is specified by PlaneAxes. Right figure: YZ is specified by PlaneAxes.</p> <div style="display: flex; justify-content: space-around; align-items: center;"> <div style="text-align: center;">  <p>XY</p> </div> <div style="text-align: center;">  <p>YZ</p> </div> </div> <p>Normally, PressProbe sets a vertical plane to the direction specified by PressOrient.</p>

Properties	Description, setting guide
PlaneRelativeRobotLocal	Set Local coordinate system number which is used when PlaneRelativeOrg and PlaneRelativeOrient are Local. Normally, set a value which is the same as RobotLocal of the force guide sequence.

4.4.2.2.5.2 Adjustment guidelines for the PressProbe object

The following describes the adjustment methods for when using the PressProbe object.

- When the robot motion vibrates:
Increase the PressFirmnessF value. However, response of the robot will be slow. Please perform proper adjustments for your operations.
To adjust the PressFirmnessF, we recommend increasing the value gradually (e.g. increase the value by 10%).
- When the robot bounces largely in the pressing direction:
If the robot repeatedly bounces largely in a few seconds, the robot motion may be restricted by LimitAccelS of the force guide sequence.
Also, it likely to happen during the execution in low power mode.
If the robot still bounces even executing in high power mode, increase the value of LimitAccelS. If the robot still bounces, decrease the value of PressFirmnessF.
- When the robot does not move along the specified trajectory:
If the robot does not move along the specified trajectory, it may be affected by the LimitAccel or LimitSpeed of the force guide sequence. Increase those values.
Also, in low power mode, it is restricted according to the maximum speed or maximum acceleration of the low power mode even the value of LimitSpeed or LimitAccel is large. Be sure to execute in high power mode.
- When the robot passes through a hole:
Decrease a value of SpiralPitch. However, it takes more time to probe the specified range. Please perform proper adjustments for your operations.
 - When the end conditions related to force are used:
Check the force in the direction specified by PressOrient during the execution.
 - When there is a difference between the position when the robot moves on the probe plane and the position when the robot moves above the hole:
Adjust ProbeDetectThresh to a value whose absolute value is smaller than the force while the robot moves on the probe plane and larger than the force while the robot moves above the hole.
 - When the end conditions related to Position are used:
Check the robot position when the robot passes through the hole.
 - When there is a difference in position between when the robot moves on the probe plane and when it moves above the hole:
Adjust the Plane to be between these two positions.
 - When PosCheckType is RobotPlane:
Adjust Plane set by PlaneNumber.
 - When PosCheckType is RelativePlane:
Adjust plane positions by PlaneRelativeX, PlaneRelativeY, and PlaneRelativeZ.
- When the robot moves away from the target during the probe motion.
Check whether the PressOrient is correct.
When the PressOrient is correct, increase an absolute value of PressForce.
However, the specified force is applied to the workpiece. Be sure to set a proper value for your workpiece.

- When it takes time:
 Increase the values for SpeedS and AccelS.
 However, the applied force to the workpiece will easy to vibrate. Please perform proper adjustments for your operations.
 Also, adjust the start position of the PressProbe object to make it as close to the hole as possible.
- When the probe motion speed is slow:
 Increase the values for SpeedS and AccelS.
 However, the applied force to the workpiece will easy to vibrate. Please perform proper adjustments for your operations.

4.4.2.2.5.3 Details on the properties of the PressProbe object

- Name Property
 This property sets a particular name that is assigned to force guide object.
 When creating the PressProbe object, a name is assigned automatically. Automatically assigned name is added a number after PressProbe (e.g. PressProbe01).
 You can change the name. Set up 16 characters at the maximum. Please use alphanumeric characters and underscores [_].
 Note: The initial character cannot be a numeric character.
- Description Property
 This property sets descriptions about force guide objects.
 You can set the character string up to 255 characters.
- Enabled Property
 This property sets whether to enable force guide objects.

When specifying True, the force guide object is executed.
 When specifying False, execute the next force guide object without executing the force guide object.
 Use this property when you want to save the force guide sequence temporary or try with different parameters by copying the force guide object during the force guide sequence creation.

Value	Description
True	Enable a force guide object.
False	Disable a force guide object.

Default: True

- StepID Property
 This property sets StepID during the execution of the force guide objects.
 It is only used when AutoStepID is False.

	Value
Minimum Value	0
Maximum value	32767

Default: Automatically set according to the numbers of the force guide sequence and the force guide object.

- AbortSeqOnFail Property
 This property sets operations when force guide object fails.
 When True is specified: If the force guide object fails, the program ends the force guide sequence and proceeds to the next SPEL statement.
 When specifying False: If force guide object fails, the program proceeds to the next force guide object without ending the force guide sequence.

Use this property when you want to continue the force guide sequence (e.g. the recovery processes are included in the force guide sequence when the force guide object fails.)

Value	Description
True	Abort the force guide sequence when the force guide object fails.
False	Start the next force guide sequence when the force guide object fails.

Default: True

■ IOPreprocEnabled Property

This property sets I/O operations when the force guide object starts.

I/O operations are defined by IOPreprocOutputBit Property and IOPreprocOutputStatus Property.

Use this property when you want to operate the hands or peripherals before the force guide object execution.

Value	Description
True	Execute I/O operation at the start.
False	I/O operation at the start is not executed.

Default: False

■ IOPreprocOutputBit Property

This property sets I/O operations (output bit) when the force guide object starts.

It is only used when IOPreprocEnabled is True.

	Value
Minimum Value	0
Maximum value	7167

Default: 0

■ IOPreprocOutputStatus Property

This property sets the output state of I/O operations when the force guide object starts.

It is only used when IOPreprocEnabled is True.

Value	Description
Off	Turn OFF the specified output bit. (Set to 0)
On	Turn ON the specified output bit. (Set to 1)

Default: Off

■ ProbeTrajectory Property

This property sets trajectory for force guide objects.

Value	Description
Straight	The robot moves along the straight line trajectory and stops at a hole or an obstacle.
Spiral	The robot moves along the spiral line trajectory and stops at a hole or an obstacle.

Default: Straight

■ ProbeDetectType Property

This property sets a target type to be detected by the PressProbe object.

Value	Description
Hole	Detect a hole on the trajectory to probe.

Value	Description
Obstacle	Detect an obstacle (convex shape) on the trajectory to probe.

Default: Hole

- **AccelS Property**

This property sets acceleration when moving the specified trajectory.

	Value (unit: [mm/sec ²])
Minimum Value	1
Maximum value	200

Default: 10

- **SpeedS Property**

This property sets acceleration when moving the specified trajectory.

	Value (unit: [mm/sec])
Minimum Value	1
Maximum value	50

Default: 10

- **SpiralDiam Property**

Set the diameter of a spiral trajectory.

This property is used when Spiral is specified by ProbeTrajectory property.

	Value (Unit: [mm])
Minimum Value	1
Maximum value	100

Default: 10

- **SpiralPitch Property**

This property sets a pitch of the spiral trajectory.

This property is used when Spiral is specified by ProbeTrajectory property.

When decreasing SpiralPitch, spirals to probe are increased in the same range. Therefore, a risk that the robot passes through the target and cannot detect it is reduced, but more time is required for probing.

When increasing SpiralPitch, spirals to probe are decreased in the same range. Therefore, a risk that the robot passes through the target and cannot detect it is increased, but the required time for probing is reduced.

	Value (Unit: [mm])
Minimum Value	0.05
Maximum value	10

Default: 1

- **DestRelativeX Property**

For the straight-line trajectory, this property sets a moving amount to X direction in the coordinate system which is specified by ForceOrient and RobotLocal of force guide sequence.

This property is used when Straight is specified by ProbeTrajectory property.

	Value (Unit: [mm])
Minimum Value	-2000

	Value (Unit: [mm])
Maximum value	2000

Default: 0

■ DestRelativeY Property

For the straight line trajectory, this property sets a motion amount in the Y direction in the coordinate system which is specified by ForceOrient and RobotLocal in the force guide sequence.

This property is used when Straight is specified by ProbeTrajectory property.

	Value (Unit: [mm])
Minimum Value	-2000
Maximum value	2000

Default: 0

■ DestRelativeZ Property

For the straight-line trajectory, this property sets a moving amount to Z direction in the coordinate system which is specified by ForceOrient and RobotLocal of force guide sequence.

This property is used when Straight is specified by ProbeTrajectory property.

	Value (Unit: [mm])
Minimum Value	-2000
Maximum value	2000

Default: 0

■ PressOrient Property

This property sets the direction to press.

Set the direction in the coordinate system specified by ForceOrient of the force guide sequence.

You can select from translation direction (+Fx to -Fz). The robot moves along the specified trajectory while pressing to a defined direction.

In the spiral trajectory, generate a spiral trajectory on the plane which is perpendicular to the specified direction.

Value	Description
+Fx	Move to the positive direction in Fx.
-Fx	Move to the negative direction in Fx.
+Fy	Move to the positive direction in Fy.
-Fy	Move to the negative direction in Fy.
+Fz	Move to the positive direction in Fz.
-Fz	Move to the negative direction in Fz.

Default: +Fz

■ PressForce Property

This property sets the force to press.

While executing the PressProbe object, the robot probes while it presses, so that the force in the PressOrient direction becomes what is specified in the PressForce property.

When pressing to positive direction, value will be negative.

When pressing to negative direction, value will be positive.

- When PressOrient is positive direction:

	Value (unit: [N])
Minimum Value	-10
Maximum value	10

Default: 0

- When PressOrient is negative direction:

	Value (unit: [N])
Minimum Value	-10
Maximum value	10

Default: 0

■ PressFirmnessF Property

This property sets a firmness for the force control function in the pressing direction during the execution of PressProbe object.

When the value of PressFirmnessF increases, the force control function will become stronger. Response to changes of the force is slow, however, vibration hardly occurs.

When the value of PressFirmnessF decreases, the force control function will become weaker. Response to changes of the force is fast, however, vibration is easy to occur.

	Value
Minimum Value	0.1
Maximum value	200

Default: 10

■ CFEnabled Property

This property sets whether to continue the force control functions after the force guide object is ended. When the force guide sequence ends even if CFEnabled is True, the force control functions will end.

Value	Description
True	The force control functions continue to the next force guide object even when a force guide object is ended.
False	The force control functions end when the force guide object is ended.

Default: False

■ ForceCheckEnabled Property

For the force guide object end conditions, this property sets conditions related to force.

The end conditions related to force is the conditions specified by ProbeDetectThresh.

Value	Description
True	Enable the end conditions related to force.
False	Disable the end conditions related to force.

Default: True

■ ProbeDetectThresh Property

For the end conditions related to force, this property sets a threshold to be determined as "detected".

- When specifying Obstacle by ProbeDetectType:
Specify a positive value.

At this time, the following will be an end condition of the force. The square root of the sum of the squares of the force in the direction that is not specified by PressOrient (e.g.: $\sqrt{F_x^2 + F_y^2}$) when selecting -Fz) exceeds the value specified by ProbeDetectThresh.

- When specifying Hole by ProbeDetectType and -Fx, -Fy, or -Fz by PressOrient:
Set a negative value.

At this time, an end condition of the force is that the force in the direction specified by PressOrient is less than the value specified by ProbeDetectThresh.

- When specifying Hole by ProbeDetectType and -Fx, -Fy, or -Fz by PressOrient:
Specify a positive value.

At this time, an end condition of the force is that the force in the direction specified by PressOrient exceeds the value specified by ProbeDetectThresh.

- When ProbeDetectType is Hole, and PressOrient is the positive direction.

	Value (unit: [N])
Minimum Value	-50
Maximum value	0

Default: 0

- When ProbeDetectType is Press, or PressOrient is the negative direction:

	Value (unit: [N])
Minimum Value	0
Maximum value	50

Default: 0

- PosCheckEnabled Property

This property sets the end conditions of the force guide object related to position.

Value	Description
True	Enable the end conditions related to position.
False	Disable the end conditions related to position.

Default: False

- PosCheckType Property

For the end conditions related to positions, this property sets whether to use Plane which is defined in advance or set a relative position from the start position of force guide object.

When specifying RobotPlane, set the end conditions by using the defined Plane. When specifying RelativePlane, reset Plane to the relative position from the force guide object start position each time the force guide object is executed.

Value	Description
RobotPlane	Use the defined Plane as the end condition.
RelativePlane	Set Plane to the relative position and use it as the end condition.

Default: RobotPlane

- PlaneNumber Property

This property sets the Plane number of the plane that will be used for end conditions related to position.

When specifying Plane in the PosCheckType property, Plane of the specified number will not be changed.

When specifying Relative in the PosCheckType property, redefine a new Plane to the specified number each time the force guide object is executed. Therefore, note that the original setting will be lost.

	Value
Minimum Value	1
Maximum value	15

Default: 1

■ PlaneEndCond Property

For the end conditions related to positions, this property sets the conditions to be determined as an end.

Value	Description
Outside	Being outside of the Plane is an end condition.
Inside	Being inside of the Plane is an end condition.

Default: Inside

■ PlaneRelativeOrg Property

For the end conditions related to positions, this property specifies which coordinate system is used to set the relative position that sets the Plane. It is used when RelativePlane is specified by PosCheckType.

Value	Description
Base	Specify a relative position based on the Base coordinate system.
Local	Specify a relative position based on the Local coordinate system. Local coordinate system number is specified by PlaneRelativeRobotLocal.
Tool	Specify a relative position based on the Tool coordinate system.

Default: Tool

■ PlaneRelativeX Property

For the end conditions related to positions, this property sets the relative position in X direction to set Plane. It is used when RelativePlane is specified by PosCheckType. X direction follows the coordinate system specified by PlaneRelativeOrg.

	Value (Unit: [mm])
Minimum Value	-2000
Maximum value	2000

Default: 0

■ PlaneRelativeY Property

For the end conditions related to positions, this property sets the relative position in Y direction to set Plane. It is used when RelativePlane is specified by PosCheckType. Y direction follows the coordinate system specified by PlaneRelativeOrg.

	Value (Unit: [mm])
Minimum Value	-2000
Maximum value	2000

Default: 0

■ PlaneRelativeZ Property

For the end conditions related to positions, this property sets the relative position in Z direction to set Plane. It is used when RelativePlane is specified by PosCheckType. Z direction follows the coordinate system specified by PlaneRelativeOrg.

	Value (Unit: [mm])
Minimum Value	-2000
Maximum value	2000

Default: 0

■ PlaneRelativeOrient Property

For the end conditions related to positions, this property sets the coordinate system to set Plane.

It is used when RelativePlane is specified by PosCheckType.

Plane is set on the axis specified by PlaneAxes, according to the coordinate system specified by PlaneRelativeOrient.

When specifying Base, Plane is set on axis specified by PlaneAxes in the Base coordinate system.

When specifying Local, Plane is set on axis specified in PlaneAxes in the Local coordinate system of the number specified by PlaneRelativeRobotLocal.

When specifying Tool, Plane is set on axis specified by PlaneAxes in the Tool coordinate system.

Value	Description
Base	Specify a Plane direction based on the Base coordinate system.
Local	Specify a Plane direction based on the Local coordinate system.
Tool	Specify a Plane direction based on the Tool coordinate system.

Default: Tool

■ PlaneAxes Property

For the end conditions related to positions, this property sets the axis to set Plane.

It is used when RelativePlane is specified by PosCheckType.

Plane is set on the axis specified by PlaneAxes, according to the coordinate system specified by PlaneRelativeOrient.

Value	Description
XY	Set Plane on the XY plane.
YZ	Set Plane on the YZ plane.
XZ	Set Plane on the XZ plane.

Default: XY

■ PlaneRelativeRobotLocal Property

For the end conditions related to positions, this property sets Local coordinate system number that specifies the relative position or direction of Plane. It is used in either of the following cases: RelativePlane is specified in PosCheckType and Local is specified in PlaneRelativeOrg. RelativePlane is specified in PosCheckType and Local is specified in PlaneRelativeOrient.

Value	Description
0 (Base)	Use the Local 0 coordinate system (Base coordinate system). It is the same as when specifying Base by PlaneRelativeOrg or PlaneRelativeOrient.
1 to 15	Use the Local coordinate system of the specified number.

Default: 0 (Base)

4.4.2.2.5.4 Details on results of the PressProbe object

- EndStatus Result
It is a result of the execution.
It succeeds when the "success conditions" described in 4.2.2.2 Relax Object are satisfied.

PressProbe Object

Value	Description
Passed	Force guide object is succeeded.
Failed	Force guide object is failed.
NoExec	Force guide object is not executed.
Aborted	Aborted during the execution of force guide object.

- Time Result
This is the time required for execution.
Unit: [sec]
- EndForces Result
It is force and torque when force guide object ends. Acquire values of Fx, Fy, Fz, Tx, Ty, and Tz.
Unit: Fx, Fy, Fz[N] / Tx, Ty, Tz [N · mm]
- EndPos Result
Positions when the force guide object ends. Acquire values of X, Y, Z, U, V, and W.
Unit: X, Y, Z [mm] / U, V, W [deg]
- AvgForces Result
Average values of force and torque during the force guide object execution. Acquire values of Fx, Fy, Fz, Tx, Ty, and Tz.
Unit: Fx, Fy, Fz [N] / Tx, Ty, Tz [N · mm]
- PeakForces Result
Peak values of force and torque during the force guide object execution. The peak value is a value which absolute value is the largest. Acquire values of Fx, Fy, Fz, Tx, Ty, and Tz.
Unit: Fx, Fy, Fz [N] / Tx, Ty, Tz [N · mm]
- ForceCondOK Result
Shows whether the end conditions related to force were satisfied.

Value	Description
True	Satisfy the end conditions related to force.
False	The end conditions related to force are not satisfied.

- TriggeredForces Result
It is the force and torque when satisfying the end conditions related to force. Acquire values of Fx, Fy, Fz, Tx, Ty, and Tz.
Unit: Fx, Fy, Fz [N] / Tx, Ty, Tz [N · mm]
- TriggeredPos Result
Positions when satisfying the end conditions related to force. Acquire values of X, Y, Z, U, V, and W.
Unit: X, Y, Z [mm] / U, V, W [deg]
- PosCondOK Result
Shows whether the end conditions related to position were satisfied.

Value	Description
True	Satisfy the end conditions related to position.
False	The end conditions related to position are not satisfied.

4.4.2.2.6 ContactProbe Object

ContactProbe object moves the robot to the specified direction until it contacts with an object such as a workpiece, and detects a position that is moved for a specified distance as a hole. If the robot contacts with an object without moving the specified distance, returns to the start position and changes the position to repeat the contact motion.

This object is used for the hole position detection of workpiece that is difficult to be detected by PressProbe (e.g. a lead part or a connector).

Even the workpiece dimension or the grasp position of the workpiece have a margin of error, the hole position can be detected stably.

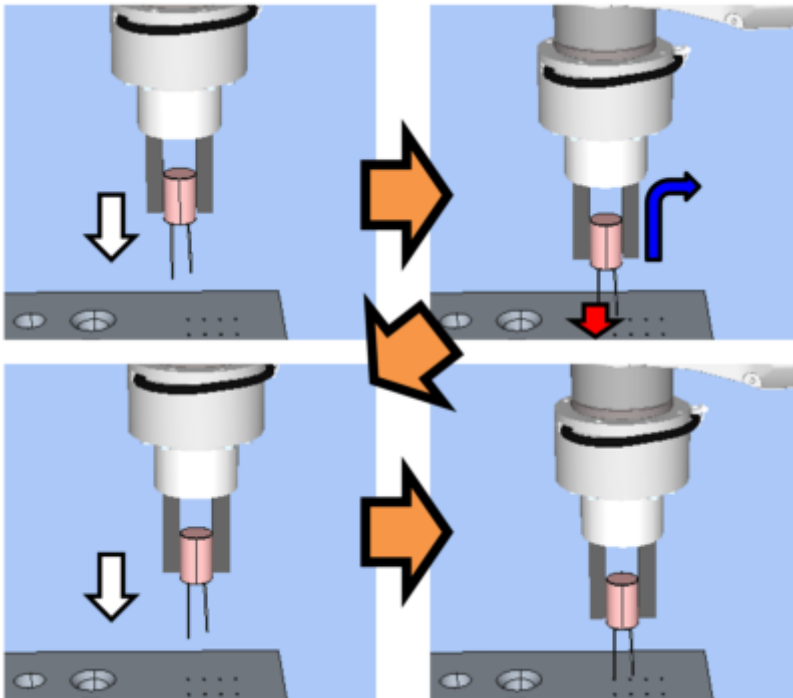

The above figure is an image of a motion by the ContactProbe object.

The robot moves from the non-contact state to a downward direction (white arrow). When the applied force (red arrow) is detected after the robot contacts with an object, it moves to the next start position of the contact (blue arrow). Repeat these motions to probe a hole.

The ContactProbe object will be succeeded when the end conditions of the positions are satisfied within the specified time in single contact motion.

The ContactProbe object always uses the end conditions related to force and position.

- When the end conditions related to force are satisfied during a single contact motion:
Determines that there is no hole at this position and the robot moves to the next contact position.
- When the end conditions related to the position are satisfied in a single contact motion:
Determines that a hole exists at this position; the detection is deemed successful.
- When the both end conditions related to the force and position are not satisfied during single contact motion.
Detection has failed due to an error state (the robot does not contact with an object and movement amount is not enough).

Each condition is as follows:

End condition	Success condition
End conditions related to force	During single contact motion, the absolute value of the force in the specified direction does not exceed that of ContactForceThresh until the end conditions related to position are satisfied. If exceeding the absolute value, the robot determines as "contacted" (= position where has no holes) and moves to the next contact position to start next contact motion.

End condition	Success condition
related to position End condition	Satisfy either one of the following within the specified time of Timeout during a contact motion:
	When PosCheckType is RobotPlane: Satisfy the state set by PlaneEndCondition for Plane set by PlaneNumber.
	When PosCheckType is RelativePlane: Move ContactDist + ContactDistMargin in ContactOrient direction.

4.4.2.2.6.1 Property setting guidelines for the ContactProbe object

Step 1. Set basic information

Set properties (Name, Description, Enabled, StepID, AbortSeqOnFail) related to the basic information.

Properties	Description, setting guide
Name	Name of the force guide object. Set a particular name.
Description	Description for the force guide object. Describe the operations. Set a character string.
Enabled	Set whether to execute the force guide object.
	True : Normal
	False : When you do not execute the force guide object (e.g., when you execute another force guide object instead).
StepID	StepID during the force guide object execution. Set an ID. StepID is an ID which is recorded in the log data. It helps you to understand which log data support a process. It is applied when AutoStepID of the force guide sequence is False.
AbortSeqOnFail	Set whether to abort or continue the force guide sequence when the force guide object fails.
	True : Normal End a force guide sequence.
	False : Cases where the force guide sequence contains recovery operations in case of failure; cases where the sequence will be able to continue even in the event of a failure.

Step 2. Set I/O processing before starting

Set properties (IOPreprocEnabled, IOPreprocOutputBit, IOPreprocOutputStatus) related to I/O processing before starting force guide object.

Properties	Description, setting guide
IOPreprocEnabled	Set whether to operate the output bit when starting the force guide object. You can operate only one output bit. To operate several output bit, use SPELFunc object.
	False : Normal
	True : You operate the output bit, as when you use or stop a peripheral device.
IOPreprocOutputBit	Set the output bit which is operated when the force guide object starts.

Properties	Description, setting guide
IOPreprocOutputStatus	Set whether to turn the output bit ON or OFF when the force guide object starts. Set the state to be output.

Step 3. Set a probe motion

Set properties (ProbeTrajectory, ProbeDetectType, AccelS, SpeedS, SpiralDiam, SpiralPitch, DestRelativeX, DestRelativeY, DestRelativeZ) related to the probe motion.

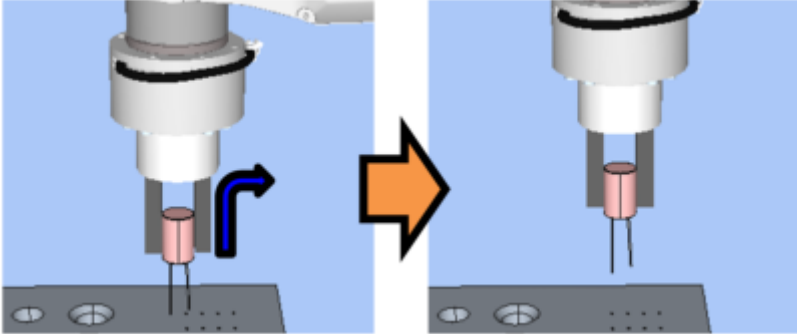
Properties	Description, setting guide
ProbeTrajectory	Set a trajectory to probe. You can select from the spiral trajectory and the straight-line trajectory. Straight : When it is clear that the target is on the specified straight line. Spiral : When the target is not on the specified straight line. The ContactProbe object takes more time than the PressProbe object. When a hole is on the specified straight line, reduce the positional difference of the start position. We recommend using Straight.
AccelS	Set the translational acceleration of the movement. As shown below, use this property for a motion which is moving to the next contact position when there is no hole and the robot contact with the object. This motion does not execute the force control functions. The robot moves with the position control.  It does not affect to the acceleration during the contact motion.
SpeedS	Set the translational velocity of the movement. As with AccelS, this property is used for a motion that moves to the next contact motion. It does not affect to the speed during the contact motion.
SpiralDiam SpiralPitch	Set a diameter and pitch of the spiral trajectory.

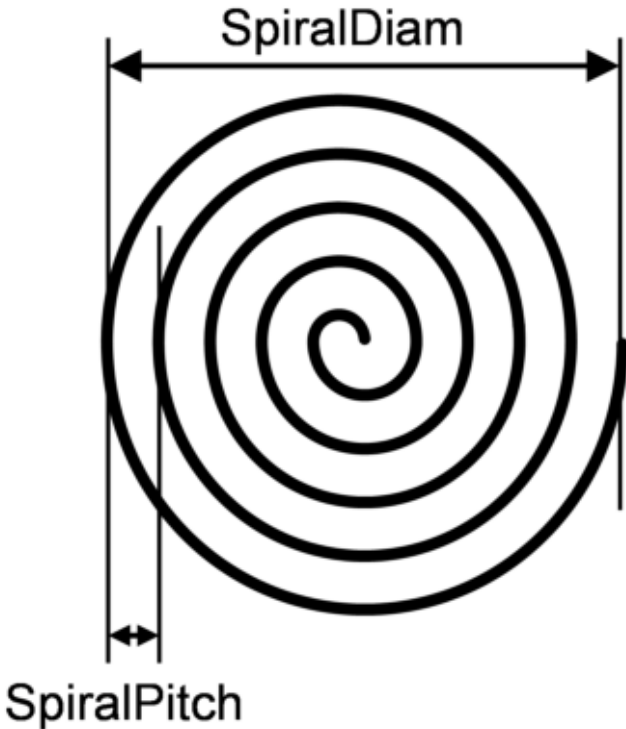
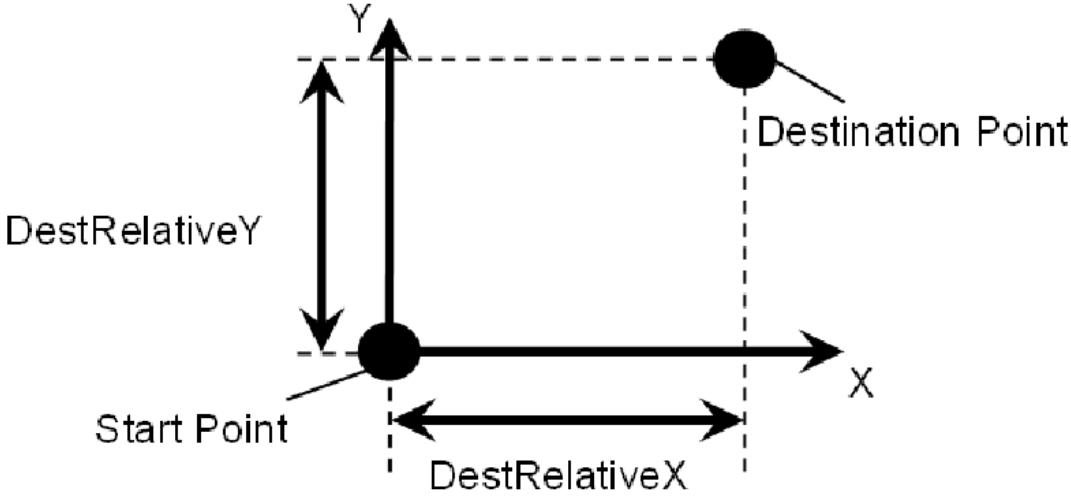
Properties	Description, setting guide
	
	<p>SpiralDiam : Set a value which is the maximum value of the distance from the start point to the detection target (positional variations are included) plus an added margin. Example: Value: 1.1 times larger than the maximum value</p>
	<p>SpiralPitch : Set a value which does not pass through the detection target. When detecting a hole, set a smaller value than the minimum interval between the holes.</p>
<p>DestRelativeX DestRelativeY DestRelativeZ</p>	<p>Set a relative movement amount to each direction from the start point of the force guide object to the destination point. As shown below, set the movement amount in the coordinate system specified by ForceOrient of the force guide sequence.</p> 

Step 4. Set the contact motion and force control functions

Set properties (ContactInterval, ContactOrient, ContactDist, ContactDistMargin, ContactFirmnessF, CFEnabled) related to the contact motion and force control functions.

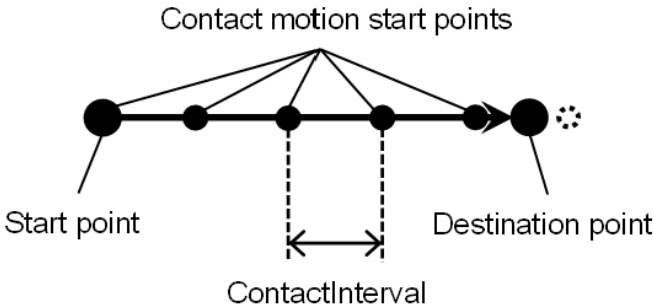
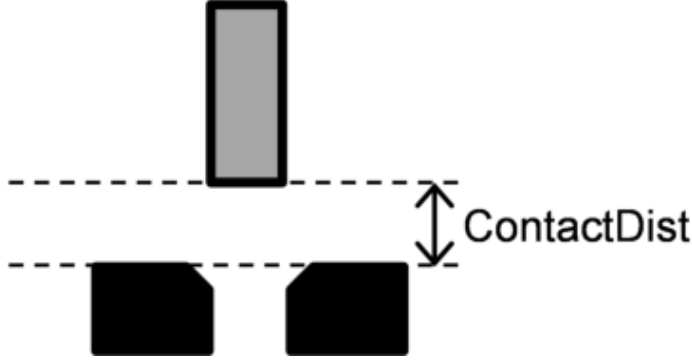
Properties	Description, setting guide
<p>ContactInterval</p>	<p>Set an interval of the contact motions.</p> <p>As shown below, the robot probes the trajectory from the start point of the ContactProbe object to the destination point based on the start point. Next contact motion starts where the robot moves the distance specified by ContactInterval.</p> <p style="text-align: center;">Contact motion start points</p>  <p>ContactProbe object performs the contact motion at the contact motion start points where are between the start point and the destination point.</p> <p>When the destination point is not a multiple of ContactInterval: Contact motion is not executed in the destination point and the next contact motion start point that exceeds the destination point.</p> <p>Be sure to set ContactInterval not pass through the detection target. Set the smaller value than the minimum interval. However, it takes time with the small value. Please perform proper adjustments for your operations.</p>
<p>ContactOrient</p>	<p>Set a direction to contact.</p> <p>The robot moves to the specified direction.</p>
<p>ContactDist ContactDistMargin</p>	<p>This property sets a distance from the start point to the target contact point and its margin.</p> <p>ContactProbe object determines as "there is a hole" when the robot moves ContactDist+ContactDistMargin in the direction specified by ContactOrient.</p>  <p>As shown above, set a distance from the workpiece tip to the contact plane of the target in ContactDist.</p> <p>ContactDistMargin sets a margin including the variations of the start point and the workpiece. If the variations are not clear, calculate by percentage of the ContactDist.</p> <p>Example: 10% of ContactDist</p>

Properties	Description, setting guide
ContactFirmnessF	<p>Set a firmness of the force control functions.</p> <p>When setting a large value: The Force Control functions become stronger, but response to changes in force is slow.</p> <p>When setting a small value: The Force Control function will become weaker. Response to changes in force is fast; however, vibrations can easily occur.</p> <p>ContactProbe object affects to the contact speed. Reference value of the contact speed can be calculated by $(\text{ContactForceThresh} / \text{ContactFirmnessF})$.</p>
CFEnabled	<p>Set whether to continue the force control functions to the next force guide object.</p> <p>False : Normal</p> <p>Turn OFF the force control functions once, then execute the next force guide object.</p>

You can check the settings of ContactOrient by a simulator. A coordinate system with grayed out except the specified direction is displayed.

However, the robot is displayed based on the current position. When you check the settings, make sure to move the robot to the position where executing the force guide object.

For details on how to check by using simulator, refer to the following manual.

"Epson RC+ 8.0 User's Guide: - Simulator - Description of Functions"

Step 5. Set the end conditions

Set properties (ContactForceThresh, PosCheckType, PlaneNumber, PlaneEndCond, Timeout) related to the end conditions.

Properties	Description, setting guide
ContactForceThresh	<p>Set a threshold to determine a contact.</p> <p>Set to approximately 3 to 5[N].</p> <p>Be sure to set a proper threshold for your workpiece.</p>
	<p>When ContactOrient is in a positive direction: Set a negative value.</p> <p>When ContactOrient is in a negative direction: Set a positive value.</p>
	<p>When setting a large absolute value: Movement speed until the robot makes contact will be fast.</p> <p>When the value is too small: Robot may not move.</p>

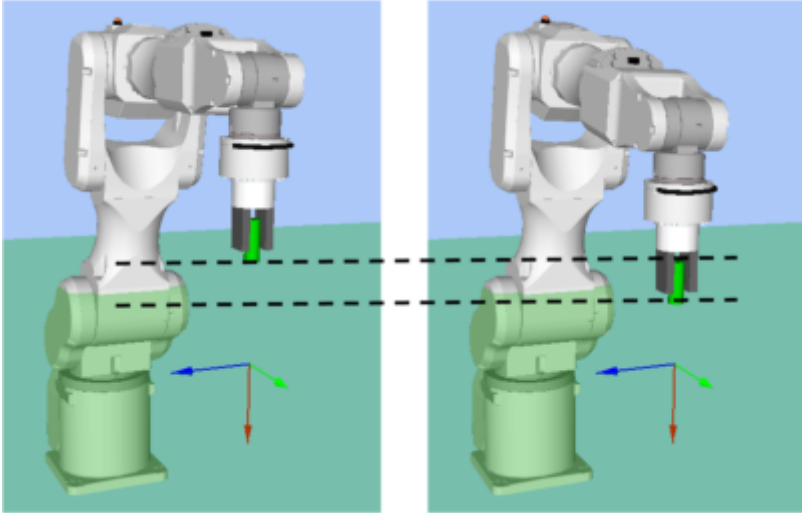
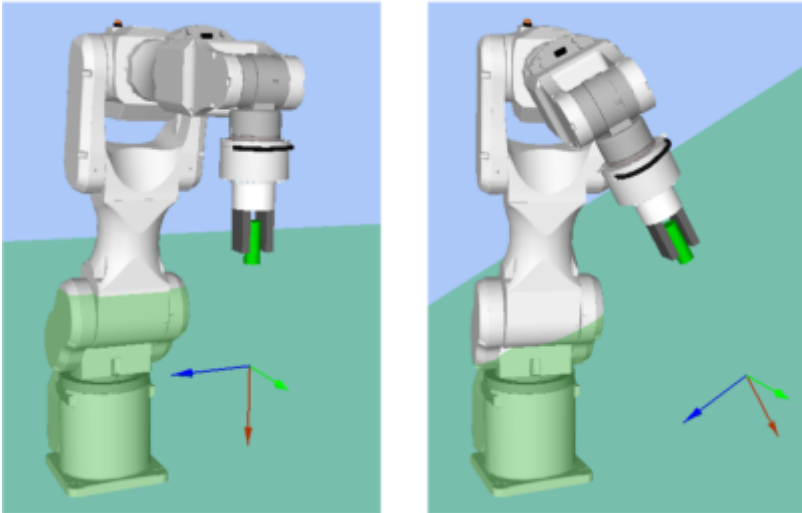
Properties	Description, setting guide
PosCheckType	<p>Select types of the end conditions related to positions.</p>
	<p>When selecting RobotPlane: End conditions are based on the set Plane. As shown below, use this property for setting the end conditions based on a defined position regardless of the position of the robot.</p> 
	<p>When selecting RelativePlane: Every time the force guide sequence is executed, create Plane at a position moved by ContactDist+ContactDistMargin in the direction specified by ContactOrient, and set as an end condition of position. As shown below, use this property for changing the end condition positions depending on the position at the start.</p> 
<p>RobotPlane : when always based on a defined position RelativePlane : when making it a condition that the robot moves a relative distance from the start position.</p>	
PlaneNumber	<p>Set Plane number which is used for an end condition of positions.</p> <p>When PosCheckType is RobotPlane: End conditions based on the specified Plane number are set.</p>

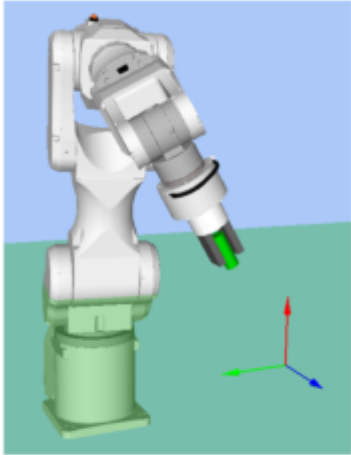
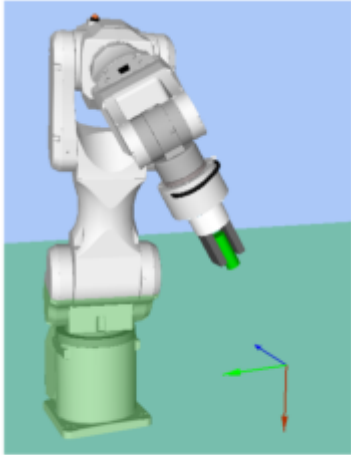
Properties	Description, setting guide
	<p>When PosCheckType is RelativePlane: Every time the force guide sequence is executed, set Plane to the specified number.</p> <p>Set an empty Plane number.</p>
PlaneEndCond	<p>Set the state of the end condition of positions. Set either Inside (inside the Plane) or Outside (outside of the Plane) as an end condition. When the robot will be the specified state, it is determined as the end conditions of the positions are satisfied. Inside the plane: It is in +Z direction of Plane.</p> <div style="display: flex; justify-content: space-around; align-items: center;">   </div> <p style="text-align: center;">Inside Outside</p>
Timeout	<p>Set a time-out period of a contact motion. Satisfy the force or position conditions in the specified time. Make sure that the value is larger than a value calculated by $(\text{ContactDist} + \text{ContactDistMargin}) / (\text{ContactForceThresh} / \text{ContactFirmnessF})$.</p>

4.4.2.2.6.2 Guidelines for Adjusting ContactProbe Object

The following describes the adjustment methods for the ContactProbe object.

- When the robot passes through a hole:
Decrease ContactInterval.
However, it takes more time to probe. Please perform proper adjustments for your operations.
- When the robot does not move to the contact direction:
Check whether the ContactOrient is correct.
When ContactOrient is correct, increase the absolute value of ContactForceThresh.
- When it takes time to perform the contact motion:
Decrease a value of ContactFirmnessF or increase an absolute value of ContactForceThresh.
However, the applied force to the workpiece is increased. Please perform proper adjustments for your operations.
- When the probe motion speed is slow:
Increase the values for SpeedS and AccelS.
- Increase SpeedS and AccelS.
When it takes time:

When the robot repeats the contact motions to a hole position several times, increase ContactInterval. Please perform proper adjustments for your operations.
Please perform proper adjustments for your operations.

4.4.2.2.6.3 Also, adjust the start point of ContactProbe object to the hole position as close as possible.

▪ Name Property

This property sets a particular name that is assigned to force guide object.

This property sets a particular name that is assigned to force guide object. When creating the ContactProbe object, name is assigned automatically. Automatically assigned name is added a number after ContactProbe (e.g. ContactProbe01).

You can change the name. Set up 16 characters at the maximum. Please use alphanumeric characters and underscore "_".

Note: The initial character cannot be a numeric character.

▪ Description Property

This property sets descriptions about force guide objects. You can set the character string up to 255 characters.

▪ Enabled Property

This property sets whether to enable force guide objects.

When specifying True, the force guide object is executed.

When specifying False, execute the next force guide object without executing the force guide object.

When specifying False, execute the next force guide object without executing the force guide object.

Value	Description
True	Enable a force guide object.
False	Disable a force guide object.

Default: True

▪ StepID Property

This property sets StepID during the execution of the force guide objects.

It is only used when AutoStepID is False.

	Value
Minimum Value	0
Maximum value	32767

Default: Automatically set according to the numbers of the force guide sequence and the force guide object.

▪ AbortSeqOnFail Property

This property sets operations when force guide object fails.

When True is specified: If the force guide object fails, the program ends the force guide sequence and proceeds to the next SPEL statement.

When specifying False: If force guide object fails, the program proceeds to the next force guide object without ending the force guide sequence.

Use this property when you want to continue the force guide sequence (e.g. the recovery processes are included in the force guide sequence when the force guide object fails.)

Value	Description
True	Abort the force guide sequence when the force guide object fails.
False	Start the next force guide sequence when the force guide object fails.

Default: True

▪ IOPreprocEnabled Property

This property sets I/O operations when the force guide object starts.

I/O operations are defined by IOPreprocOutputBit Property and IOPreprocOutputStatus Property. Use this property when you want to operate the hands or peripherals before the force guide object execution.

Value	Description
True	Execute I/O operation at the start.
False	I/O operation at the start is not executed.

Default: False

- IOPreprocOutputBit Property

This property sets I/O operations (output bit) when the force guide object starts. It is only used when IOPreprocEnabled is True.

	Value
Minimum Value	0
Maximum value	7167

Default: 0

- IOPreprocOutputStatus Property

This property sets the output state of I/O operations when the force guide object starts.

It is only used when IOPreprocEnabled is True.

Value	Description
Off	Turn OFF the specified output bit. (Set to 0)
On	Turn ON the specified output bit. (Set to 1)

Default: Off

- ProbeTrajectory Property

This property sets trajectory for force guide objects.

Value	Description
Straight	Move the start point along with the straight-line trajectory and repeat the contact motion.
Spiral	Move the start point along with the spiral trajectory and repeat the contact motion.

Default: Straight

- AccelS Property

This property sets acceleration when moving to a start point of contact.

	Value (unit: [mm/sec ²])
Minimum Value	1
Maximum value	5000

Default: 200

- SpeedS Property

This property sets speed when moving to a start point of contact.

	Value (unit: [mm/sec])
Minimum Value	1
Maximum value	250

Default: 50

▪ **SpiralDiam Property**

Set the diameter of a spiral trajectory.

This property is used when Spiral is specified by ProbeTrajectory property.

	Value (Unit: [mm])
Minimum Value	1
Maximum value	100

Default: 10

▪ **SpiralPitch Property**

This property sets a pitch of the spiral trajectory.

This property is used when Spiral is specified by ProbeTrajectory property.

	Value (Unit: [mm])
Minimum Value	0.05
Maximum value	10

Default: 1

▪ **DestRelativeX Property**

For the straight-line trajectory, this property sets a moving amount to X direction in the coordinate system which is specified by ForceOrient and RobotLocal of force guide sequence.

This property is used when Straight is specified by ProbeTrajectory property.

	Value (Unit: [mm])
Minimum Value	-2000
Maximum value	2000

Default: 0

▪ **DestRelativeY Property**

For the straight line trajectory, this property sets a motion amount in the Y direction in the coordinate system which is specified by ForceOrient and RobotLocal in the force guide sequence.

This property is used when Straight is specified by ProbeTrajectory property.

	Value (Unit: [mm])
Minimum Value	-2000
Maximum value	2000

Default: 0

▪ **DestRelativeZ Property**

For the straight-line trajectory, this property sets a moving amount to Z direction in the coordinate system which is specified by ForceOrient and RobotLocal of force guide sequence.

This property is used when Straight is specified by ProbeTrajectory property.

	Value (Unit: [mm])
Minimum Value	-2000
Maximum value	2000

Default: 0

▪ **ContactInterval Property**

This property sets a movement amount of the contact start position.

When the robot contacts during the contact motion, the next contact motion starts where the robot moves the distance specified by ContactInterval.

	Value (Unit: [mm])
Minimum Value	0.05
Maximum value	10

Default: 0.1

- ContactOrient Property

Set a hole direction.

Set the direction in the coordinate system specified by ForceOrient of the force guide sequence.

Select from translation direction (+Fx to -Fz). The robot probes a hole while moving to the specified direction.

Value	Description
+Fx	Move to the positive direction in Fx.
-Fx	Move to the negative direction in Fx.
+Fy	Move to the positive direction in Fy.
-Fy	Move to the negative direction in Fy.
+Fz	Move to the positive direction in Fz.
-Fz	Move to the negative direction in Fz.

Default: +Fz

- ContactDist Property

This property sets an assumed distance between the start position and the hole position.

When the robot moves ContactDist + ContactDistMargin, it determines as "a hole is detected" and proceeds to the next force object.

	Value (Unit: [mm])
Minimum Value	0.1
Maximum value	50

Default: 10

- ContactDistMargin Property

This property sets a margin which is added to a distance between the start point and the hole position.

Be sure to set a value with consideration for the maximum difference of each distance. When the robot moves ContactDist + ContactDistMargin, it determines as "a hole is detected" and proceeds to the next force object.

	Value (Unit: [mm])
Minimum Value	0.1
Maximum value	50

Default: 10

- ContactFirmnessF Property

This property sets a firmness of force control functions during execution of the force guide object.

When the value of ContactFirmnessF increases, the force control function will become stronger. Response to changes of the force is slow, however, vibration hardly occurs.

When the value of ContactFirmnessF decreases, the force control function will become weaker. Response to changes of the force is fast, however, vibration is easy to occur.

	Value
Minimum Value	0.1
Maximum value	200

Default: 10

■ CFEnabled Property

This property sets whether to continue the force control functions after the force guide object is ended.

When the force guide sequence ends even if CFEnabled is True, the force control functions will end.

Value	Description
True	The force control functions continue to the next force guide object even when a force guide object is ended.
False	The force control functions end when the force guide object is ended.

Default: False

■ ContactForceThresh Property

This property sets a threshold of force to determine the contact. When the value specified by this property is exceeded during execution of the PressProbe object, the robot returns to the contact start position, and then moves to the next contact start position.

- When ContactOrient is in positive direction:

	Value (unit: [N])
Minimum Value	-10
Maximum value	0

Default: -5

- When ContactOrient is in negative direction:

	Value (unit: [N])
Minimum Value	0
Maximum value	10

Default: 5

■ PosCheckType Property

For the end conditions related to positions, this property sets whether to use Plane which is defined in advance or set a relative position from the start position of force guide object.

When specifying RobotPlane, set the end conditions by using the defined Plane.

When specifying RelativePlane, reset Plane to the relative position from the force guide object start position each time the force guide object is executed. Relative position is calculated by directions and movement amount specified by ContactOrient, ContactDist, and ContactDistMargin.

Value	Description
RobotPlane	Use the defined Plane as the end condition.
RelativePlane	Set Plane to the relative position and use it as the end condition.

Default: RobotPlane

- PlaneNumber Property

This property sets the Plane number of the plane that will be used for end conditions related to position.

When specifying Plane in the PosCheckType property, Plane of the specified number will not be changed.

When specifying Relative in the PosCheckType property, redefine a new Plane to the specified number each time the force guide object is executed. Therefore, note that the original setting will be lost.

	Value
Minimum Value	1
Maximum value	15

Default: 1

- PlaneEndCond Property

For the end conditions related to positions, this property sets the conditions to be determined as an end.

Value	Description
Outside	Being outside of the Plane is an end condition.
Inside	Being inside of the Plane is an end condition.

Default: Inside

- Timeout Property

This property sets the time-out period of the force guide object.

When the single contact motion is not satisfied end conditions of force or position even if exceeding the time specified by Timeout, it is determined as failure of ContactProbe object.

After the determination, end the force guide sequence according to AbortSeqOnFail or proceed to the next force guide object.

When the end conditions of force are satisfied, the robot moves to the next contact position and repeats the contact motion.

When the end conditions of positions are satisfied, the robot determines as "a hole is detected" and proceeds to the next force object.

	Value (unit: [sec])
Minimum Value	0.1
Maximum value	60

Default: 10

4.4.2.2.6.4 Details on the results of the ContactProbe object

- EndStatus Result

It is a result of the execution.

It succeeds when the "success conditions" described in 4.2.2.2 Relax Object are satisfied.

ContactProbe Object

Value	Description
Passed	Force guide object is succeeded.
Failed	Force guide object is failed.
NoExec	Force guide object is not executed.
Aborted	Aborted during the execution of force guide object.

- Time Result

This is the time required for execution.

Unit: [sec]

- TimedOut Result

Shows whether the time-out period set in the Timeout property was reached.

Value	Description
True	Reached the time-out period.
False	End before reaching to the time-out period.

- EndForces Result

It is force and torque when force guide object ends. Acquire values of Fx, Fy, Fz, Tx, Ty, and Tz.

Unit: Fx, Fy, Fz [N] / Tx, Ty, Tz [N · mm]

- EndPos Result

Positions when the force guide object ends. Acquire values of X, Y, Z, U, V, and W.

Unit: X, Y, Z [mm] / U, V, W [deg]

- AvgForces Result

Average values of force and torque during the force guide object execution. Acquire values of Fx, Fy, Fz, Tx, Ty, and Tz.

Unit: Fx, Fy, Fz [N] / Tx, Ty, Tz [N · mm]

- PeakForces Result

Peak values of force and torque during the force guide object execution. The peak value is a value which absolute value is the largest. Acquire values of Fx, Fy, Fz, Tx, Ty, and Tz.

Unit: Fx, Fy, Fz [N] / Tx, Ty, Tz [N · mm]

- TriggeredForces Result

It is the force and torque when satisfying the end conditions related to force. Acquire values of Fx, Fy, Fz, Tx, Ty, and Tz.

Unit: Fx, Fy, Fz [N] / Tx, Ty, Tz [N · mm]

- TriggeredPos Result

Positions when satisfying the end conditions related to force. Acquire values of X, Y, Z, U, V, and W.

Unit: X, Y, Z [mm] / U, V, W [deg]

- PosCondOK Result

Shows whether the end conditions related to position were satisfied.

Value	Description
True	Satisfy the end conditions related to position.
False	The end conditions related to position are not satisfied.

4.4.2.2.7 Press Object

The Press object is the Force Guide object that operates the robot so that it presses with the specified force in the specified direction.

Also, it is possible to follow another specified direction simultaneously like Relax object.

If the Press object is executed in the non-contact state, the robot will move in the direction of the specified force. Use this object for press motion or pushing of assembly. Even if the workpiece dimension or the grasp position of the workpiece have a margin of error, the robot can keep a certain force stably.

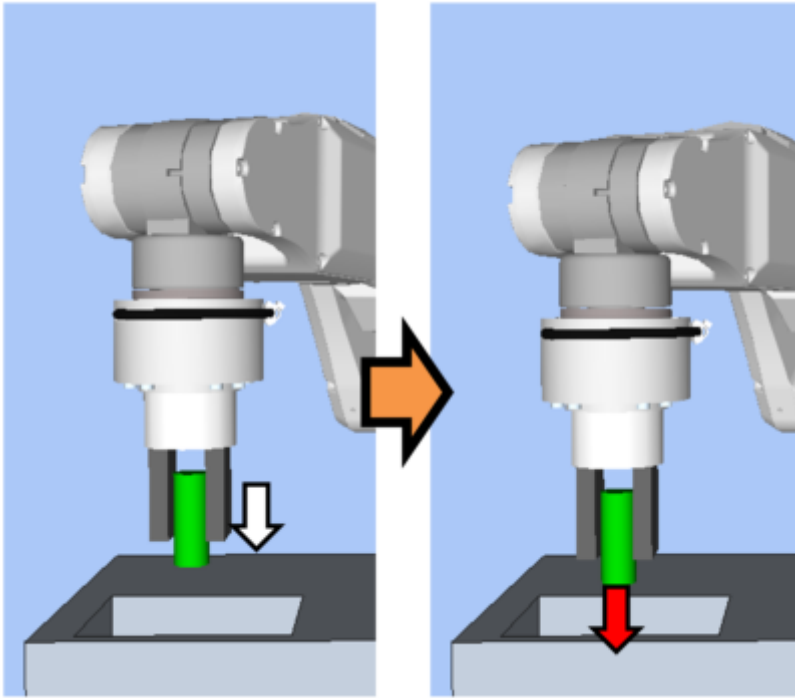

The figure above shows a motion by the Press object. When executing in the non-contact state, the robot moves to the pressing direction (white arrow). After the robot contacts with the object, it keeps a state with a certain force (red arrow) is applied. You can start the object with a contact state.

The Press object succeeds if the end conditions are satisfied within the specified time. The Press object can use the end conditions related to force, position, and I/O.

Each end condition sets whether to use in ForceCheckEnabled, PosCheckEnabled, and IOCheckEnabled. If no end condition is set, the object will always be succeeded.

When more than one end conditions are set, you can select how to combine the end conditions from AND or OR in EndCheckOperator.

Each condition is as follows:

End condition	Success condition
End conditions related to force	During the specified Timeout period, keep all of the following conditions satisfied for the length of the HoldTimeThresh period:
	When ForceCheckPolarity is Inside: In Fx, Fy, and Fz, the axis specified to Press- or Press+ by Control Mode is inside the range of PressForce - PressCheckToIF to PressForce + PressCheckToIF.
	When ForceCheckPolarity is Outside: In Fx, Fy, and Fz, the axis specified by Press- or Press+ in ControlMode is outside the range of PressForce - PressCheckToIF to PressForce + PressCheckToIF.
	When ForceCheckPolarity is Inside: In Tx, Ty, and Tz, the axis specified Press- or Press+ by ControlMode is inside the range of PressForce - PressCheckToIT to PressForce + PressCheckToIT.
	When ForceCheckPolarity is Outside: In Tx, Ty, and Tz, the axis specified by Press- or Press+ in ControlMode is outside the range of PressForce - PressCheckToIF to PressForce + PressCheckToIF.
	ForceCheckMode is PressFollow and ForceCheckPolarity is inside: In Fx, Fy, and Fz, the axis specified Follow in ControlMode is within the range of -FollowCheckToIF to +FollowCheckToIF.
	When ForceCheckMode is PressFollow and ForceCheckPolarity is Outside: In Fx, Fy, and Fz, the axis specified Follow by ControlMode is outside the range of -FollowCheckToIF to +FollowCheckToIF.
	ForceCheckMode is PressFollow and ForceCheckPolarity is inside: The axis, which is specified to Follow by , ControlMode in Tx, Ty, or Tz: The axis should be within the range of -FollowCheckToIT to +FollowCheckToIT.
related to position End condition	Satisfy either one of the following within the specified time of Timeout:
	When PosCheckType is RobotPlane: Satisfy the state set by PlaneEndCondition for Plane set by PlaneNumber.
	When PosCheckType is RelativePlane: Satisfy the state set by PlaneEndCondition for the relative plane set by PlaneRelativeX, PlaneRelativeY, PlaneRelativeZ, PlaneRelativeOrg, PlaneRelativeOrient, PlaneAxes, PlaneRelativeRobotLocal.
End conditions related to I/O	Input bit specified by IOCheckInputBit should be the state specified by IOCheckInputStatus within the time specified by Timeout.

4.4.2.2.7.1 Property setting guidelines for the Press object

Step 1. Set basic information

Set properties (Name, Description, Enabled, StepID, AbortSeqOnFail) related to the basic information.

Properties	Description, setting guide
Name	This property sets names of force guide objects. Set a particular name.

Properties	Description, setting guide
Description	This property sets descriptions about force guide objects. Describe the operations. Set a character string.
Enabled	Set whether to execute the force guide object.
	True : Normal
	False : When you do not execute the force guide object (e.g., when you execute another force guide object instead).
StepID	StepID during the force guide object execution. Set an ID. StepID is an ID which is recorded in the log data. It helps you to understand which log data support a process. It is applied when AutoStepID of the force guide sequence is False.
AbortSeqOnFail	Set whether to abort or continue the force guide sequence when the force guide object fails.
	True : Normal End a force guide sequence.
	False : Cases where the force guide sequence contains recovery operations in case of failure; cases where the sequence will be able to continue even in the event of a failure.

Step 2. Set I/O processing before starting

Set properties (IOPreprocEnabled, IOPreprocOutputBit, IOPreprocOutputStatus) related to I/O processing before starting force guide object.

Properties	Description, setting guide
IOPreprocEnabled	Set whether to operate the output bit when starting the force guide object. You can operate only one output bit. To operate several output bit, use SPELFunc object.
	False : Normal
	True : You operate the output bit, as when you use or stop a peripheral device.
IOPreprocOutputBit	Set the output bit which is operated when the force guide object starts.
IOPreprocOutputStatus	Set whether to turn the output bit ON or OFF when the force guide object starts. Set the state to be output.
StepID	StepID during the force guide object execution. Set an ID. StepID is an ID which is recorded in the log data. It helps you to understand which log data support a process. It is applied when AutoStepID of the force guide sequence is False.
AbortSeqOnFail	Set whether to abort or continue the force guide sequence when the force guide object fails.
	True : Normal End a force guide sequence.
	False : Cases where the force guide sequence contains recovery operations in case of failure; cases where the sequence will be able to continue even in the event of a failure.

Step 3. Set force control functions

Set properties (Fx_ControlMode, ..., Tz_ControlMode, Fx_PressForce, ..., Tz_PressForce, Fx_Firmness, ..., Tz_Firmness, CFEnabled) related to the force control function.

Properties	Description, setting guide
Fx_ControlMode Fy_ControlMode Fz_ControlMode Tx_ControlMode Ty_ControlMode Tz_ControlMode	Mode of the force control functions to each direction.
	Press+ : The robot moves in the positive direction of each axis and presses.
	Press- : The robot moves in the negative direction of each axis and presses.
	When specifying Follow: Perform the follow motion by the force control functions.
	When specifying Disabled: Force control functions are disabled.
	Set the ControlMode in pressing direction to Press+ or Press-. Set ControlMode where you want to follow to Follow. One or more directions must be set to a status other than Disabled.
Fx_PressForce Fy_PressForce Fz_PressForce Tx_PressForce Ty_PressForce Tz_PressForce	Set the force and torque set to each direction. It is used when ControlMode is Press+ or Press-
	When ControlMode is Press+: Set a negative value.
	When ControlMode is Press-: Set a positive value.
	For Peg in Hole or assembly tasks, usually 3 to 5[N] or -3 to -5[N] is used in Fx, Fy, and Fz. However, a proper value differs depending on tasks or workpiece.
Fx_Firmness Fy_Firmness Fz_Firmness Tx_Firmness Ty_Firmness Tz_Firmness	Set a firmness of the force control functions to each direction.
	When setting a large value: The Force Control functions become stronger, but response to changes in force is slow.
	When setting a small value: The Force Control function will become weaker. Response to changes in force is fast; however, vibrations can easily occur.
CFEnabled	Set whether to continue the force control functions to the next force guide object.
	False : Normal Turn OFF the force control functions once, then execute the next force guide object.
	True : When you want to start the next force guide object, and keep the force constant after contact with the prior object.

You can check the settings of ControlMode by a simulator.

A coordinate system with grayed out except the enabled direction is displayed.

However, the robot is displayed based on the current position. When you check the settings, make sure to move the robot to the position where executing the force guide object.

For details on how to check by using simulator, refer to the following manual.

"Epson RC+ 8.0 User's Guide: - Simulator - Description of Functions"

Step 4. Set basic information for end conditions

Set properties (EndCheckOperator, Timeout) related to combinations of end conditions and time-out.

Properties	Description, setting guide
EndCheckOperator	This property sets how to combine the end conditions related to force, position, and I/O.
	AND : End when both conditions are satisfied.
	OR: End when one or more conditions is satisfied.
Timeout	Set the time-out duration.
	When the end conditions are not set: Time-out period is the execution time.
	When the end conditions are set: Fails when the end conditions are not satisfied within the specified time.

Step 5. Set end conditions related to force

Set properties (ForceCheckEnabled, ForceCheckMode, ForceCheckPolarity, PressCheckToIF, PressCheckToIT, FollowCheckToIF, FollowCheckToIT, HoldTimeThresh) related to the end conditions of force.

Properties	Description, setting guide
ForceCheckEnabled	This property sets whether to enable the end conditions of force. True : When enabling the end conditions related to force.
ForceCheckMode	Target direction of determination.
	Press : Only the pressing direction is evaluated. Directions (Press+, Press-) specified by ControlMode are evaluated.
	PressFollow : The pressing direction and follow direction are evaluated. Directions (Press+, Press-, Follow) specified by ControlMode are evaluated.
ForceCheckPolarity	Polar of the end conditions related to force.
	Inside : Normally set. Being inside of the specified range is an end condition.
	Outside : Being outside of the specified range is an end condition. Use Outside when using a special end condition such as starting with the pressing state and making it as an end condition that the pressing state is released.
PressCheckToIF PressCheckToIT	This property sets the pressing direction range of the end conditions related to force. Set a range of the end conditions. PressCheckToIF is applied for Fx, Fy, and Fz, PressCheckToIT is applied for Tx, Ty, and Tz. It monitors that the force of directions (Press+, Press-) specified by ControlMode of Fx, Fy, and Fz are within the range of PressForce -PressCheckToIF to PressForce +PressCheckToIF. It monitors that the torque of the force directions (Press+, Press-) specified by ControlMode of Tx, Ty, and Tz is within the range of PressForce -PressCheckToIT to PressForce +PressCheckToIT. The following is an image of PressCheckToIF.

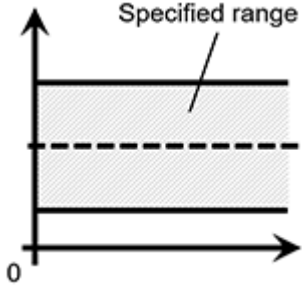
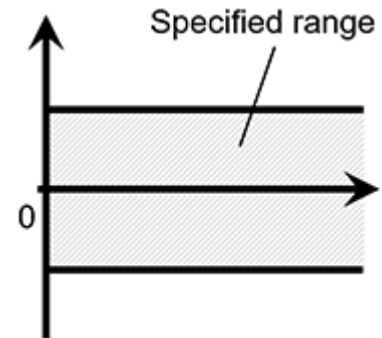
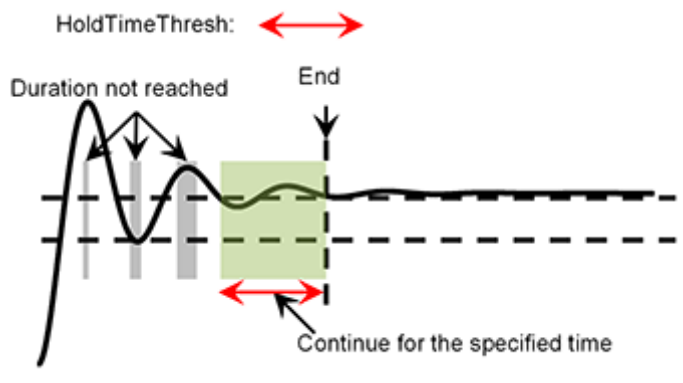
Properties	Description, setting guide
	
<p>FollowCheckToIF FollowCheckToIT</p>	<p>This property sets the range in the follow direction of the end conditions related to force. FollowCheckToIF is applied for Fx, Fy, and Fz, FollowCheckToIT is applied for Tx, Ty, and Tz. It monitors that the force of directions specified to Follow by ControlMode of Fx, Fy, and Fz are within the range of -FollowCheckToIF to +FollowCheckToIF. It monitors that the torque of directions specified to Follow by ControlMode of Tx, Ty, and Tz are within the range of -FollowCheckToIT to +FollowCheckToIT. The following is an image of InsertCheckToIF.</p> 
<p>HoldTimeThresh</p>	<p>Set the duration time which is used to determine whether the end conditions have satisfied. As shown below, if the specified condition continues for the time specified by HoldTimeThresh, it is determined as the end conditions are satisfied.</p>  <p>Normally, set to "0". Set the time for stabilizing the motion when the results of the next force guide object are unstable. We recommend setting the time according to the actual result which is executed after temporarily disabling the end conditions.</p>

Step 6. Set end conditions about position

Set properties (PosCheckEnabled, PosCheckType, PlaneNumber, PlaneEndCond, PlaneRelativeOrg, PlaneRelativeX, PlaneRelativeY, PlaneRelativeZ, PlaneRelativeOrient, PlaneAxes, PlaneRelativeRobotLocal) related to the end conditions of the positions.

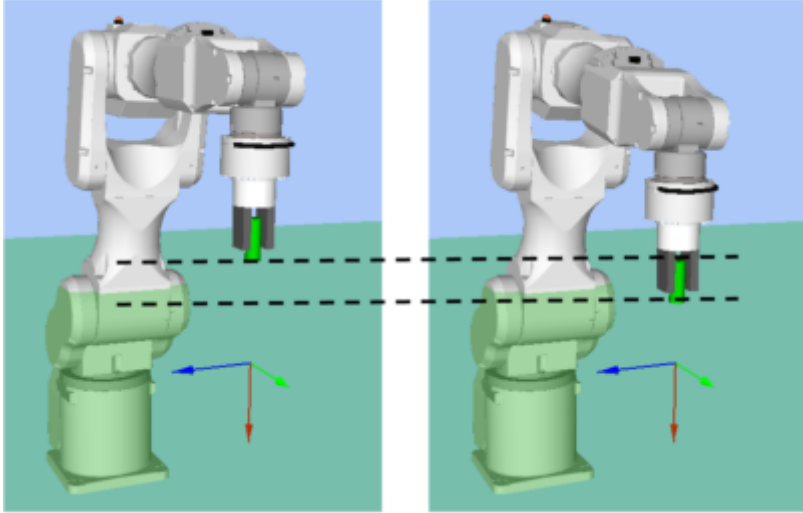
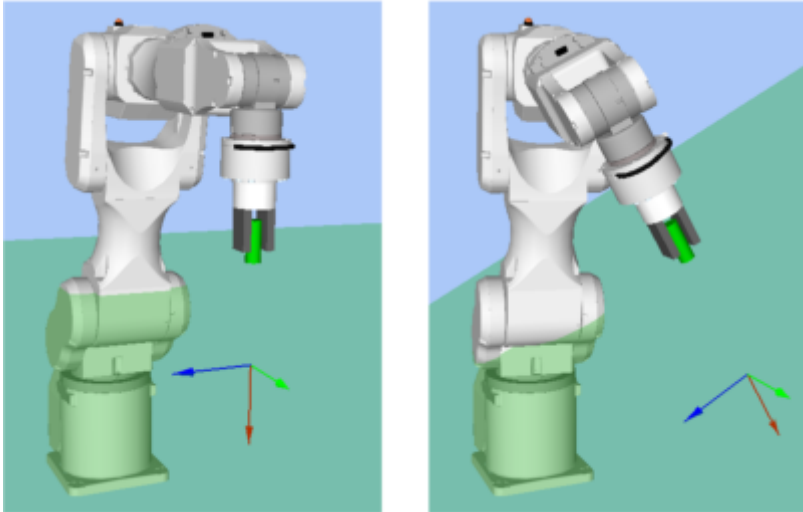
Properties	Description, setting guide
PosCheckEnabled	<p>This property sets whether to enable the end conditions of positions.</p> <p>True : When the end conditions related to position are enabled.</p> <p>False : When the end conditions related to position are disabled.</p>
PosCheckType	<p>Types of the end conditions related to positions.</p> <p>When selecting RobotPlane: End conditions are based on the set Plane. As shown below, use this property for setting the end conditions based on a defined position regardless of the position of the robot.</p> 
	<p>When selecting RelativePlane: Every time the force guide sequence is executed, create Plane at a relative position from the current position and set as an end condition of position. As shown below, use this property for changing the end condition positions depending on the position at the start.</p>  <p>RobotPlane : when always based on a defined position RelativePlane : when making it a condition that the robot moves a relative distance from the start position.</p>

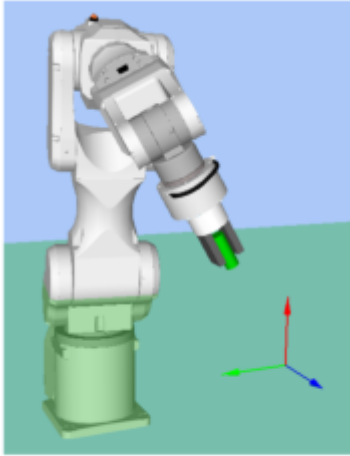
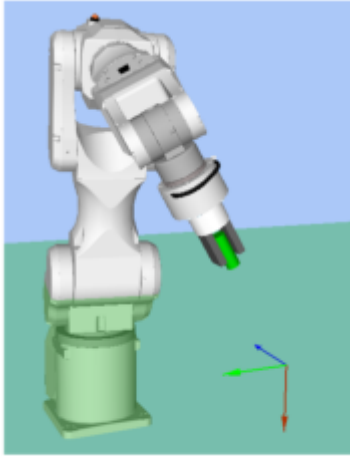
Properties	Description, setting guide
PlaneNumber	Set Plane number which is used for an end condition of positions.
	When PosCheckType is RobotPlane: End conditions based on the specified Plane number are set.
	When PosCheckType is RelativePlane: Every time the force guide sequence is executed, set Plane to the specified number.
	Set an empty Plane number.
PlaneEndCond	<p>Set the state of the end condition of positions. Set either Inside (inside the Plane) or Outside (outside of the Plane) as an end condition. When the robot will be the specified state, it is determined as the end conditions of the positions are satisfied. Inside the plane: It is in +Z direction of Plane.</p> <div style="display: flex; justify-content: space-around; align-items: center;"> <div style="text-align: center;">  <p>Inside</p> </div> <div style="text-align: center;">  <p>Outside</p> </div> </div>
PlaneRelativeOrg	<p>Set which coordinate system direction is used as a reference when expressing the offset amount to the origin of Plane. The left figure below is an example to set Base. Specify a relative distance based on the Base coordinate system. It is an example that the negative value is set in PlaneRelativeZ. The right figure below is an example to set Tool. Specify a relative distance based on the Tool coordinate system. It is an example that the positive value is set in PlaneRelativeZ.</p>

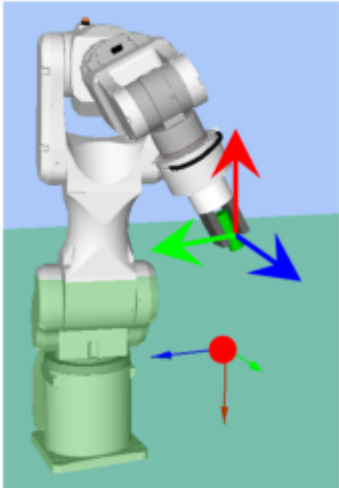
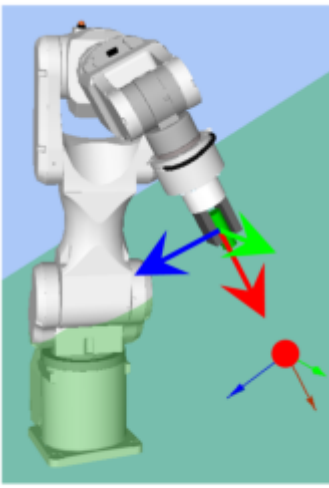
Properties	Description, setting guide
	<div style="display: flex; justify-content: space-around; align-items: center;">   </div> <div style="display: flex; justify-content: space-around; margin-top: 10px;"> Base Tool </div> <p data-bbox="432 808 1433 949">The Local or Tool coordinate systems are used only in that direction and origin position does not affect. To set the position of an end condition in the robot motion direction, normally set the same value as ForceOrient of the force guide sequence.</p>
PlaneRelativeX PlaneRelativeY PlaneRelativeZ	<p data-bbox="432 999 1321 1066">Set offset amount in each direction from the current position to the origin of Plane. Direction will be the coordinate system direction specified by PlaneRelativeOrg.</p>
PlaneRelativeOrient	<p data-bbox="432 1122 1423 1370">Set a coordinate system based on the Plane direction. The left figure below is an example to set Base. Reference direction of the Plane matches the Base coordinate system regardless of the robot orientation at the start of the force guide object. The right figure below is an example to set Tool. Reference direction of the Plane changes along with the robot orientation at the start of the force guide object.</p>

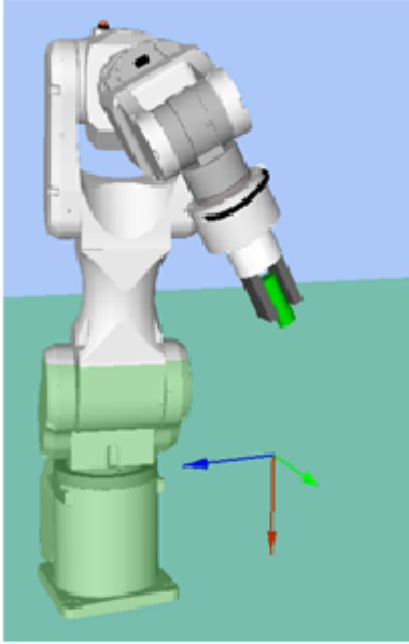
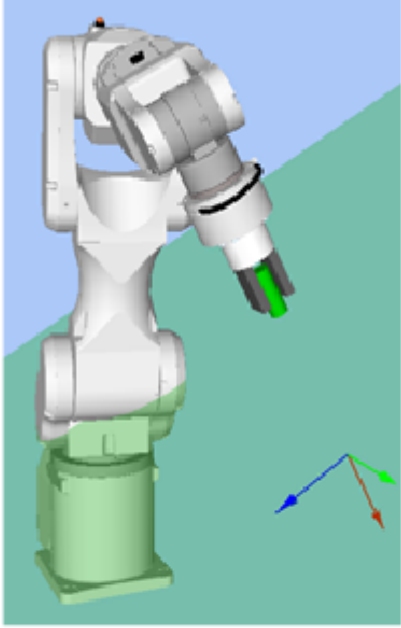
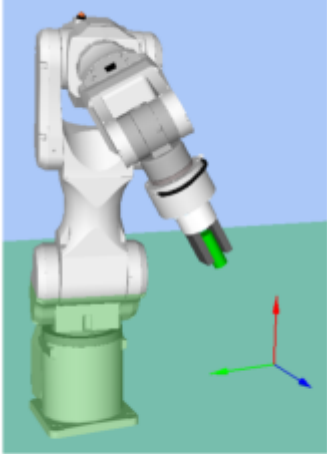
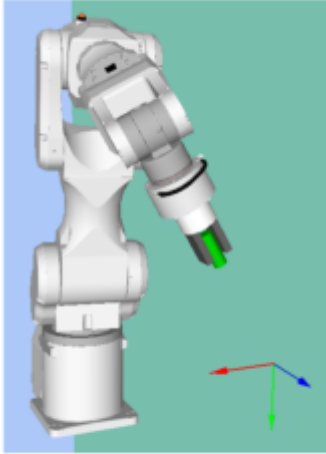
Properties	Description, setting guide
	<div style="display: flex; justify-content: space-around; align-items: center;"> <div style="text-align: center;">  <p>Ex. to set Base</p> </div> <div style="text-align: center;">  <p>Ex. to set Tool</p> </div> </div> <p>Since a plane which is perpendicular to the robot motion direction will be the end conditions, normally set the same value as ForceOrient of the force guide sequence.</p>
PlaneAxes	<p>Set a Plane direction Based on the coordinate system specified by PlaneRelativeOrient, plane is set to a direction set by PlaneAxes. The following figure is an example when Base is set by PlaneRelativeOrient. Left figure: XY is specified by PlaneAxes. Right figure: YZ is specified by PlaneAxes.</p> <div style="display: flex; justify-content: space-around; align-items: center;"> <div style="text-align: center;">  <p>XY</p> </div> <div style="text-align: center;">  <p>YZ</p> </div> </div> <p>Normally, set Plane which is perpendicular to the robot motion direction.</p>
PlaneRelativeRobotLocal	<p>Set Local coordinate system number which is used when PlaneRelativeOrg and PlaneRelativeOrient are Local. Normally, set a value which is the same as RobotLocal of the force guide sequence.</p>

Step 7. Set end conditions related to I/O

Set properties (IOCheckEnabled, IOCheckInputBit, IOCheckInputStatus) related to the end conditions of I/O.

Properties	Description, setting guide
IOCheckEnabled	This property sets whether to enable the end conditions of I/O. True : When the end conditions related to I/O are enabled.
IOCheckInputBit	Set an input bit which is monitored as an end condition.
IOCheckInputStatus	Set a state of the input bit to be an end condition. If the input bit specified by IOCheckInputBit will be the state specified by IOCheckInputStatus, it is determined as the end conditions are satisfied.

4.4.2.2.7.2 Adjustment guidelines for the Press object

The following describes the adjustment methods when using the Press object.

- When the robot motion vibrates:
Increase the Firmness value. However, response of the robot will be slow. Please perform proper adjustments for your operations.
To adjust the Firmness, we recommend changing the value gradually (e.g. increase the value by 10% from its present state).
- When the robot bounces largely in the pressing direction:
If the robot repeatedly bounces largely in a few seconds, the robot motion may be restricted by LimitAccelS of the force guide sequence.
Also, it likely to happen during the execution in low power mode.
If the robot still bounces even executing in high power mode, increase the value of LimitAccelS.
If the robot still bounces, decrease the value of Firmness in pressing direction.
- When the robot does not reach to the target force:
Decrease the Firmness value of the pressing direction.
However, the robot motion may be easy to vibrate. Please perform proper adjustments for your operations.
To adjust the Firmness, we recommend changing the value gradually (e.g. decrease the value by 10% from its current state).
- When the robot does not move to the pressing direction:
Confirm that the ControlMode where the robot does not move is either Press+ or Press-.
When Press+ or Press- is set, confirm whether the PressForce is set to "0".
- When the robot moves in the reverse direction:
Confirm that the ControlMode where the robot moves in the reverse direction is either Press+ or Press-.
When the robot is set to assumed direction, confirm the ForceOrient or RobotLocal of the force guide sequence, tool coordinate system, or local coordinate system.

4.4.2.2.7.3 Details on the properties of the Press object

- Name Property
This property sets a particular name that is assigned to force guide object. When creating the Press object, a name is assigned automatically. Automatically assigned name is added a number after Press (e.g. Press01).
You can change the name. Set up 16 characters at the maximum. Please use alphanumeric characters and underscores [_].
Note: The initial character cannot be a numeric character.
- Description Property
This property sets descriptions about force guide objects. You can set the character string up to 255 characters.

■ Enabled Property

This property sets whether to enable force guide objects.

When specifying True, the force guide object is executed. When specifying False, execute the next force guide object without executing the force guide object.

Use this property when you want to save the force guide sequence temporary or try with different parameters by copying the force guide object during the force guide sequence creation.

Value	Description
True	Enable a force guide object.
False	Disable a force guide object.

Default: True

■ StepID Property

This property sets StepID during the execution of the force guide objects. It is only used when AutoStepID is False.

	Value
Minimum Value	0
Maximum value	32767

Default: Automatically set according to the numbers of the force guide sequence and the force guide object.

■ AbortSeqOnFail Property

This property sets operations when force guide object fails.

When True is specified: If the force guide object fails, the program ends the force guide sequence and proceeds to the next SPEL statement. When specifying False: If force guide object fails, the program proceeds to the next force guide object without ending the force guide sequence.

Use this property when you want to continue the force guide sequence (e.g. the recovery processes are included in the force guide sequence when the force guide object fails.)

Value	Description
True	Abort the force guide sequence when the force guide object fails.
False	Start the next force guide sequence when the force guide object fails.

Default: True

■ IOPreprocEnabled Property

This property sets I/O operations when the force guide object starts.

I/O operations are defined by IOPreprocOutputBit Property and IOPreprocOutputStatus Property. Use this property when you want to operate the hands or peripherals before the force guide object execution.

Value	Description
True	Execute I/O operation at the start.
False	I/O operation at the start is not executed.

Default: False

■ IOPreprocOutputBit Property

This property sets I/O operations (output bit) when the force guide object starts. It is only used when IOPreprocEnabled is True.

	Value
Minimum Value	0
Maximum value	7167

Default: 0

■ IOPreprocOutputStatus Property

This property sets the output state of I/O operations when the force guide object starts. It is only used when IOPreprocEnabled is True.

Value	Description
Off	Turn OFF the specified output bit. (Set to 0)
On	Turn ON the specified output bit. (Set to 1)

Default: Off

■ Fx_ControlMode Property

Set the control mode in Fx direction in the coordinate system specified by ForceOrient of the force guide sequence.

When specifying Disabled, the force control functions to Fx direction are not executed. When specifying Press+ or Press-, the force control function in the Fx direction is executed in the press mode. In the press mode, the robot presses so as to become the force specified by Fx_PressForce. When specifying Follow, the force control functions to Fx direction is executed as the follow mode. In the follow mode, the robot moves so that the external force will be "0". Therefore, when the external force is applied, the robot moves to follow it.

Value	Description
Disabled	Disable the force control functions.
Press+	The force control functions are executed to press in the positive direction.
Press-	The force control functions are executed to press in the negative direction.
Follow	The force control functions are executed to perform the Follow motion.

Default: Disabled

■ Fx_PressForce Property

This property sets pressing force to Fx direction during the execution of force guide objects. It is used when Fx_ControlMode is Press+ or Press-

When ControlMode is Press+:

	Value (unit: [N])
Minimum Value	-250
Maximum value	0

Default: 0

When ControlMode is Press-

	Value (unit: [N])
Minimum Value	0
Maximum value	250

Default: 0

■ Fx_Firmness Property

This property sets a firmness of force control functions in Fx direction during the execution of force guide object. It is used when Fx_ControlMode is Press+, Press-, or Follow

When the value of Fx_Firmness increases, the force control function in the Fx direction will become stronger. Response to changes in force is slow; however, vibration rarely occurs. When Fx_Firmness decreases, the force control function in the Fx direction will become weaker. Response to changes in force becomes faster; however, vibrations easily occur.

	Value
Minimum Value	0.1
Maximum value	200

Default: 10

■ Fy_ControlMode Property

Set the control mode in Fy direction in the coordinate system specified by ForceOrient of the force guide sequence.

When specifying Disabled, the force control functions to Fy direction are not executed.

When specifying Press+ or Press-, the force control function in the Fy direction is executed in the press mode. In the press mode, the robot presses so as to become the force specified by Fy_PressForce. When specifying Follow, the force control functions to Fy direction is executed as the follow mode. In the follow mode, the robot moves so that the external force will be "0". Therefore, when the external force is applied, the robot moves to follow it.

Value	Description
Disabled	Disable the force control functions.
Press+	The force control functions are executed to press in the positive direction.
Press-	The force control functions are executed to press in the negative direction.
Follow	The force control functions are executed to perform the Follow motion.

Default: Disabled

■ Fy_PressForce Property

This property sets pressing force to Fy direction during the execution of force guide objects. It is used when Fy_ControlMode is Press+ or Press-

When ControlMode is Press+:

	Value (unit: [N])
Minimum Value	-250
Maximum value	0

Default: 0

When ControlMode is Press-

	Value (unit: [N])
Minimum Value	0
Maximum value	250

Default: 0

■ Fy_Firmness Property

This property sets a firmness of force control functions in Fy direction during the execution of force guide object. It is used when Fy_ControlMode is Press+, Press-, or Follow.

When the value of Fy_Firmness increases, the force control function in Fy direction will become stronger. Response to changes of the force is slow, however, vibration hardly occurs. When Fy_Firmness decreases, the force control function in Fy direction will become weaker. Response to changes of the force is fast, however, vibration is easy to occur.

	Value
Minimum Value	0.1
Maximum value	200

Default: 10

■ Fz_ControlMode Properties

Set the control mode in Fz direction in the coordinate system specified by ForceOrient of the force guide sequence.

When specifying Disabled, the force control functions to Fz direction are not executed. When specifying Press+ or Press-, the force control function in the Fz direction is executed in the press mode. In the press mode, the robot presses so as to become the force specified by Fz_PressForce. When specifying Follow, the force control functions to Fz direction is executed as the follow mode. In the follow mode, the robot moves so that the external force will be "0". Therefore, when the external force is applied, the robot moves to follow it.

Value	Description
Disabled	Disable the force control functions.
Press+	The force control functions are executed to press in the positive direction.
Press-	The force control functions are executed to press in the negative direction.
Follow	The force control functions are executed to perform the Follow motion.

Default: Disabled

■ Fz_PressForce Property

This property sets pressing force to Fz direction during the execution of force guide objects. It is used when Fz_ControlMode is Press+ or Press-

When ControlMode is Press+:

	Value (unit: [N])
Minimum Value	-250
Maximum value	0

Default: 0

When ControlMode is Press-

	Value (unit: [N])
Minimum Value	0
Maximum value	250

Default: 0

■ Fz_Firmness Property

This property sets a firmness of force control functions in Fz direction during the execution of force guide object. It is used when Fz_ControlMode is Press+, Press- or Follow.

When the value of Fz_Firmness increases, the force control function in Fz direction will become stronger. Response to changes in force is slow; however, vibration rarely occurs. When Fz_Firmness decreases, the force control function in Fz direction will become weaker. Response to changes of the force is fast, however, vibration is easy to occur.

	Value
Minimum Value	0.1
Maximum value	200

Default: 10

■ Tx_ControlMode Property

Set the control mode in Tx direction in the coordinate system specified by ForceOrient of the force guide sequence.

When specifying Disabled, the force control functions in the Tx direction are not executed. When specifying Press+ or Press-, the force control function in the Tx direction is executed in the press mode. In the press mode, the robot presses so as to become the force specified by Tx_PressForce. When specifying Follow, the force control functions to Tx direction is executed as the follow mode. In the follow mode, the robot moves so that the external torque will be "0". Therefore, when the external torque is applied, the robot moves to follow it.

Value	Description
Disabled	Disable the force control functions.
Press+	The force control functions are executed to press in the positive direction.
Press-	The force control functions are executed to press in the negative direction.
Follow	The force control functions are executed to perform the Follow motion.

Default: Disabled

■ Tx_PressForce Property

This property sets pressing force to Tx direction during the execution of force guide objects. It is used when Tx_ControlMode is Press+ or Press-

When ControlMode is Press+:

	Value (unit: [N · mm])
Minimum Value	-18000
Maximum value	0

Default: 0

When ControlMode is Press-

	Value (unit: [N · mm])
Minimum Value	0
Maximum value	18000

Default: 0

▪ Tx_Firmness Property

This property sets a firmness of force control functions in Tx direction during the execution of force guide object. It is used when Tx_ControlMode is Press+, Press-, or Follow.

When the value of Tx_Firmness increases, the force control function in Tx direction will become stronger. Response to changes of the torque is slow, however, vibration hardly occurs. When Tx_Firmness decreases, the force control function to Tx direction will become weaker. Response to changes of the torque is fast, however, vibration is easy to occur.

	Value
Minimum Value	10
Maximum value	1000000

Default: 3000

▪ Ty_ControlMode Property

Set the control mode in Ty direction in the coordinate system specified by ForceOrient of the force guide sequence.

When specifying Disabled, the force control functions in the Ty direction are not executed. When specifying Press+ or Press-, the force control function in the Ty direction is executed in the press mode. In the press mode, the robot presses so as to become the force specified by Ty_PressForce. When specifying Follow, the force control functions to Ty direction is executed as the follow mode. In the follow mode, the robot moves so that the external torque will be "0". Therefore, when the external torque is applied, the robot moves to follow it.

Value	Description
Disabled	Disable the force control functions.
Press+	The force control functions are executed to press in the positive direction.
Press-	The force control functions are executed to press in the negative direction.
Follow	The force control functions are executed to perform the Follow motion.

Default: Disabled

▪ Ty_PressForce Property

This property sets pressing force to Ty direction during the execution of force guide objects. It is used when Ty_ControlMode is Press+ or Press-

When ControlMode is Press+:

	Value (unit: [N · mm])
Minimum Value	-18000

	Value (unit: [N · mm])
Maximum value	0

Default: 0

When ControlMode is Press-

	Value (unit: [N · mm])
Minimum Value	0
Maximum value	18000

Default: 0

▪ Ty_Firmness Property

This property sets a firmness of force control functions in Ty direction during the execution of force guide object. It is used when Ty_ControlMode is Press+, Press-, or Follow.

When the value of Ty_Firmness increases, the force control function in Ty direction will become stronger. Response to changes of the torque is slow, however, vibration hardly occurs. When Ty_Firmness decreases, the force control function to Ty direction will become weaker. Response to changes of the torque is fast, however, vibration is easy to occur.

	Value
Minimum Value	10
Maximum value	1000000

Default: 3000

▪ Tz_ControlMode Property

Set the control mode in Tz direction in the coordinate system specified by ForceOrient of the force guide sequence.

When specifying Disabled, the force control functions to Tz direction are not executed. When specifying Press+ or Press-, the force control function in the Tz direction is executed in the press mode. In the press mode, the robot presses so as to become the force specified by Tz_PressForce. When specifying Follow, the force control functions to Tz direction is executed as the follow mode. In the follow mode, the robot moves so that the external torque will be "0". Therefore, when the external torque is applied, the robot moves to follow it.

Value	Description
Disabled	Disable the force control functions.
Press+	The force control functions are executed to press in the positive direction.
Press-	The force control functions are executed to press in the negative direction.
Follow	The force control functions are executed to perform the Follow motion.

Default: Disabled

▪ Tz_PressForce Property

This property sets pressing force to Tz direction during the execution of force guide objects. It is used when Tz_ControlMode is Press+ or Press-.

- When ControlMode is Press+:

	Value (unit: [N · mm])
Minimum Value	-18000
Maximum value	0

Default: 0

- When ControlMode is Press-

	Value (unit: [N · mm])
Minimum Value	0
Maximum value	18000

Default: 0

▪ Tz_Firmness Property

This property sets a firmness of force control functions in Tz direction during the execution of force guide object. It is used when Tz_ControlMode is Press+, Press-, or Follow.

When the value of Tz_Firmness increases, the force control function in Tz direction will become stronger. Response to changes of the torque is slow, however, vibration hardly occurs. When Tz_Firmness decreases, the force control function to Tz direction will become weaker. Response to changes of the torque is fast, however, vibration is easy to occur.

	Value
Minimum Value	10
Maximum value	1000000

Default: 3000

▪ CFEnabled Property

This property sets whether to continue the force control functions after the force guide object is ended. When the force guide sequence ends even if CFEnabled is True, the force control functions will end.

	Value
True	The force control functions continue to the next force guide object even when a force guide object is ended.
False	The force control functions end when the force guide object is ended.

Default: False

▪ EndCheckOperator Property

This property sets the combination conditions when using several end conditions of the force guide object.

When specifying AND, if all of the enabled end conditions are satisfied, the force guide object execution ends. The execution is deemed successful, and it proceeds to the next force guide object.

When specifying OR, if some of the enabled end conditions are satisfied, the force guide object execution ends. The execution is determined as succeeded and proceed to the next force guide object.

Value	Description
OR	Combine as OR condition.
AND	Combine as AND condition.

Default: AND

- ForceCheckEnabled Property

For the force guide object end conditions, this property sets conditions related to force.

Value	Description
True	Enable the end conditions related to force.
False	Disable the end conditions related to force.

Default: False

- ForceCheckMode Property

This property sets the direction used as an end condition related to force.

Value	Description
Press	Direction (Press+, Press-) specified by ControlMode is a force condition.
PressFollow	Direction (Press+, Press-, and Follow) specified by ControlMode is a force condition.

Default: Press

- ForceCheckPolarity Property

For an end condition related to force, this property sets whether the end condition is being inside or outside of the specified range.

Value	Description
Outside	Being outside of the specified range is an end condition.
Inside	Being inside of the specified range is an end condition.

Default: Inside

- PressCheckToIF Property

This property sets the range of the end conditions related to force. It is used when ForceCheckEnabled is True in a direction where Press is specified by ControlMode in Fx, Fy, and Fz directions.

Determine that the force in each direction is inside or outside of the range of PressForce -PressCheckToIF to PressForce +PressCheckToIF.

	Value (unit: [N])
Minimum Value	0.1
Maximum value	10

Default: 1

- PressCheckToIT Property

This property sets the range of the end conditions related to force. It is used when ForceCheckEnabled is True in a direction where Press is specified by ControlMode in Tx, Ty, and Tz directions.

Determine that the force in each direction is inside or outside of the range of PressForce -PressCheckToIT to PressForce +PressCheckToIT.

	Value (unit: [N · mm])
Minimum Value	If the sequence version is 7.5.1: 1 If the sequence version is 7.4.0: 100
Maximum value	10000

Default: 500

- FollowCheckToIF Property

This property sets the range of the end conditions related to force. It is used when ForceCheckEnabled is True and

ForceCheckMode is set to PressFollow in a direction where Follow is specified by ControlMode in Fx, Fy, and Fz directions.

Determine that the force in each direction is inside or outside of the range of -FollowCheckToIF to +FollowCheckToIF.

	Value (unit: [N])
Minimum Value	0.1
Maximum value	10

Default: 1

■ FollowCheckToIT Property

This property sets the range of the end conditions related to force. It is used when ForceCheckEnabled is True and ForceCheckMode is set to PressFollow in a direction where Follow is specified by ControlMode in Tx, Ty, and Tz directions.

Determine that the force in each direction is inside or outside of the range of -FollowCheckToIT to +FollowCheckToIT.

	Value (unit: [N · mm])
Minimum Value	If the sequence version is 7.5.1: 1 If the sequence version is 7.4.0: 100
Maximum value	10000

Default: 500

■ HoldTimeThresh Property

This property sets the duration time until the determination of the end conditions related to force. It is used when ForceCheckEnabled is True.

When the specified condition continues for the time specified by HoldTimeThresh, it is determined as the end conditions are satisfied.

	Value (unit: [sec])
Minimum Value	0
Maximum value	10

Default: 0

■ PosCheckEnabled Property

This property sets the end conditions of the force guide object related to position.

Value	Description
True	Enable the end conditions related to position.
False	Disable the end conditions related to position.

Default: False

■ PosCheckType Property

For the end conditions related to positions, this property sets whether to use Plane which is defined in advance or set a relative position from the start position of force guide object.

When specifying RobotPlane, set the end conditions by using the defined Plane. When specifying RelativePlane, reset Plane to the relative position from the force guide object start position each time the force guide object is executed.

Value	Description
RobotPlane	Use the defined Plane as the end condition.
RelativePlane	Set Plane to the relative position and use it as the end condition.

Default: RobotPlane

■ PlaneNumber Property

This property sets the Plane number of the plane that will be used for end conditions related to position.

When specifying Plane in the PosCheckType property, Plane of the specified number will not be changed. When specifying Relative in the PosCheckType property, redefine a new Plane to the specified number each time the force guide object is executed. Therefore, note that the original setting will be lost.

	Value
Minimum Value	1
Maximum value	15

Default: 1

■ PlaneEndCond Property

For the end conditions related to positions, this property sets the conditions to be determined as an end.

Value	Description
Outside	Being outside of the Plane is an end condition.
Inside	Being inside of the Plane is an end condition.

Default: Inside

■ PlaneRelativeOrg Property

For the end conditions related to positions, this property specifies which coordinate system is used to set the relative position that sets the Plane. It is used when RelativePlane is specified by PosCheckType.

Value	Description
Base	Specify a relative position based on the Base coordinate system.
Local	Specify a relative position based on the Local coordinate system.
	Local coordinate system number is specified by PlaneRelativeRobotLocal.
Tool	Specify a relative position based on the Tool coordinate system.

Default: Tool

■ PlaneRelativeX Property

For the end conditions related to positions, this property sets the relative position in X direction to set Plane. It is used when RelativePlane is specified by PosCheckType. X direction follows the coordinate system specified by PlaneRelativeOrg.

	Value (Unit: [mm])
Minimum Value	-2000
Maximum value	2000

Default: 0

■ PlaneRelativeY Property

For the end conditions related to positions, this property sets the relative position in Y direction to set Plane. It is used when RelativePlane is specified by PosCheckType. Y direction follows the coordinate system specified by PlaneRelativeOrg.

	Value (Unit: [mm])
Minimum Value	-2000

	Value (Unit: [mm])
Maximum value	2000

Default: 0

- PlaneRelativeZ Property

For the end conditions related to positions, this property sets the relative position in Z direction to set Plane. It is used when RelativePlane is specified by PosCheckType. Z direction follows the coordinate system specified by PlaneRelativeOrg.

	Value (Unit: [mm])
Minimum Value	-2000
Maximum value	2000

Default: 0

- PlaneRelativeOrient Property

For the end conditions related to positions, this property sets the coordinate system to set Plane. It is used when RelativePlane is specified by PosCheckType.

Plane is set on the axis specified by PlaneAxes, according to the coordinate system specified by PlaneRelativeOrient.

When specifying Base, Plane is set on axis specified by PlaneAxes in the Base coordinate system. When specifying Local, Plane is set on axis specified in PlaneAxes in the Local coordinate system of the number specified by PlaneRelativeRobotLocal. When specifying Tool, Plane is set on axis specified by PlaneAxes in the Tool coordinate system.

Value	Description
Base	Specify a Plane direction based on the Base coordinate system.
Local	Specify a Plane direction based on the Local coordinate system.
Tool	Specify a Plane direction based on the Tool coordinate system.

Default: Tool

- PlaneAxes Property

For the end conditions related to positions, this property sets the axis to set Plane. It is used when RelativePlane is specified by PosCheckType.

Plane is set on the axis specified by PlaneAxes, according to the coordinate system specified by PlaneRelativeOrient.

Value	Description
XY	Set Plane on the XY plane.
YZ	Set Plane on the YZ plane.
XZ	Set Plane on the XZ plane.

Default: XY

- PlaneRelativeRobotLocal Property

For the end conditions related to positions, this property sets Local coordinate system number that specifies the relative position or direction of Plane. It is used in either of the following cases: RelativePlane is specified in PosCheckType and Local is specified in PlaneRelativeOrg. RelativePlane is specified in PosCheckType and Local is specified in PlaneRelativeOrient.

Value	Description
0 (Base)	Use the Local 0 coordinate system (Base coordinate system). It is the same as when specifying Base by PlaneRelativeOrg or PlaneRelativeOrient.

Value	Description
1 to 15	Use the Local coordinate system of the specified number.

Default: 0 (Base)

- IOCheckEnabled Property

This property sets the end conditions of the force guide object related to I/O.

Value	Description
True	Enable the end conditions related to I/O.
False	Disable the end conditions related to I/O.

Default: False

- IOCheckInputBit Property

This property sets the bit of determination target of the end conditions related to I/O. It is used when IOCheckEnabled is True.

	Value
Minimum Value	0
Maximum value	7167

Default: 0

- IOCheckInputStatus Property

This property sets the determination conditions of the end conditions related to I/O. It is used when IOCheckEnabled is True.

According to the bit specified by IOCheckInputBit, it is determined as the end conditions are satisfied.

Value	Description
Off	When the input bit is OFF (0), it is determined as the end conditions are satisfied.
On	When the input bit is ON (1), it is determined as the end conditions are satisfied.

Default: Off

- Timeout Property

This property sets the time-out period of the force guide object.

Even if the time specified in the Timeout property is exceeded, the Press object is deemed to have failed if the conditions enabled in ForceCheckEnabled, PosCheckEnabled, and IOCheckEnabled were not satisfied.

After the determination, end the force guide sequence according to AbortSeqOnFail or proceed to the next force guide object.

When ForceCheckEnabled, PosCheckEnabled, and IOCheckEnabled are False, end the force guide object after time specified by Timeout is passed. Determined as succeeded and proceed to the next force guide object.

	Value (unit: [sec])
Minimum Value	0.1
Maximum value	60

Default: 10

4.4.2.2.7.4 Details on the results of the Press object

- EndStatus Result

It is a result of the execution.

It succeeds when the "success conditions" described in 4.2.2.2 Relax Object are satisfied.

Press Object

Value	Description
Passed	Force guide object is succeeded.
Failed	Force guide object is failed.
NoExec	Force guide object is not executed.
Aborted	Aborted during the execution of force guide object.

- Time Result

This is the time required for execution.

Unit: [sec]

- TimedOut Result

Shows whether the time-out period set in the Timeout property was reached.

Value	Description
True	Reached the time-out period.
False	End before reaching to the time-out period.

- EndForces Result

It is force and torque when force guide object ends. Acquire values of Fx, Fy, Fz, Tx, Ty, and Tz.

Unit: Fx, Fy, Fz [N] / Tx, Ty, Tz [N · mm]

- EndPos Result

Positions when the force guide object ends. Acquire values of X, Y, Z, U, V, and W.

Unit: X, Y, Z [mm] / U, V, W [deg]

- AvgForces Result

Average values of force and torque during the force guide object execution. Acquire values of Fx, Fy, Fz, Tx, Ty, and Tz.

Unit: Fx, Fy, Fz [N] / Tx, Ty, Tz [N · mm]

- PeakForces Result

Peak values of force and torque during the force guide object execution. The peak value is a value which absolute value is the largest. Acquire values of Fx, Fy, Fz, Tx, Ty, and Tz.

Unit: Fx, Fy, Fz [N] / Tx, Ty, Tz [N · mm]

- ForceCondOK Result

Shows whether the end conditions related to force were satisfied.

Value	Description
True	Satisfy the end conditions related to force.
False	The end conditions related to force are not satisfied.

- TriggeredForces Result

It is the force and torque when satisfying the end conditions related to force. Acquire values of Fx, Fy, Fz, Tx, Ty, and Tz.

Unit: Fx, Fy, Fz [N] / Tx, Ty, Tz [N · mm]

- TriggeredPos Result

Positions when satisfying the end conditions related to force. Acquire values of X, Y, Z, U, V, and W.

Unit: X, Y, Z [mm] / U, V, W [deg]

■ PosCondOK Result

Shows whether the end conditions related to position were satisfied.

Value	Description
True	Satisfy the end conditions related to position.
False	The end conditions related to position are not satisfied.

■ IOCondOK Result

Shows whether the end conditions related to I/O were satisfied.

Value	Description
True	Satisfy the end conditions related to I/O.
False	The end conditions related to I/O are not satisfied.

4.4.2.2.8 PressMove Object

The PressMove object is a Force Guide object that moves the robot along the specified trajectory while pressing in the specified direction with the specified force.

Also, it is possible to follow to another specified direction simultaneously like FollowMove object.

When executing the PressMove object without contacting, the robot moves to a direction of the specified force in addition to the specified path. Use this object for pressing, screw driving, or polishing for Peg In Hole or assembly. Even the workpiece dimension or the grasp positions of the workpiece have a margin of error, the robot can move with maintaining the stably force.

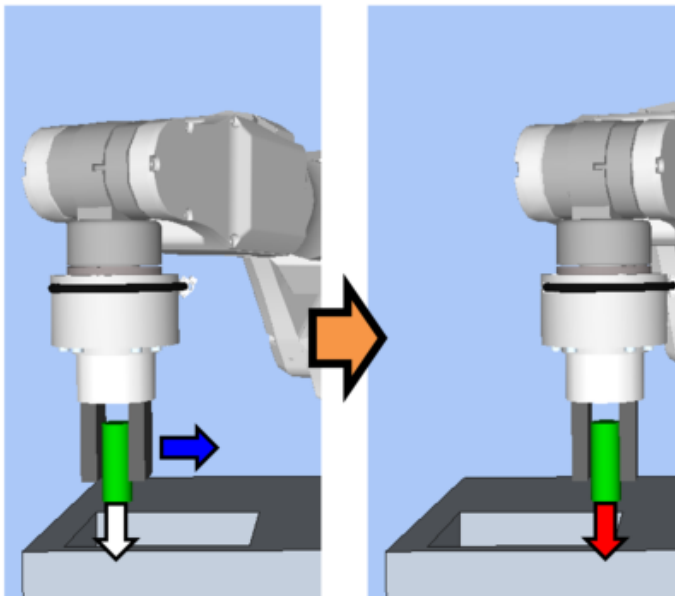

The figure above shows the motion of the PressMove object. When executing in the non-contact state, the robot moves to the pressing direction (white arrow) while moving the trajectory (blue arrow). After the robot contacts with the object, it moves the specified trajectory while maintaining a state with a certain force (red arrow) is applied.

The PressMove object is deemed successful if the end conditions are satisfied while the robot is moving along the specified trajectory. It can use the end conditions related to positions, I/O, and force.

Each end condition sets whether to use in ForceCheckEnabled, PosCheckEnabled, and IOCheckEnabled. If no end condition is set, the object will always be succeeded. When more than one end conditions are set, you can select how to combine the end conditions from AND or OR in EndCheckOperator.

Each condition is as follows:

End condition	Success condition
End conditions related to force	While the robot moves the specified trajectory, keep satisfying the following all items in the time specified by HoldTimeThresh.
	When ForceCheckPolarity is Inside: In Fx, Fy, and Fz, the axis specified by Press- or Press+ in ControlMode is inside the range of PressForce - PressCheckToIF to PressForce + PressCheckToIF.
	When ForceCheckPolarity is Outside: In Fx, Fy, and Fz, the axis specified by Press- or Press+ in ControlMode is outside the range of PressForce - PressCheckToIF to PressForce + PressCheckToIF.
	When ForceCheckPolarity is Inside: In Tx, Ty, and Tz, the axis specified by Press- or Press+ in ControlMode is inside the range of PressForce - PressCheckToIF to PressForce + PressCheckToIF.
	When ForceCheckPolarity is Outside: In Tx, Ty, and Tz, the axis specified by Press- or Press+ in ControlMode is outside the range of PressForce - PressCheckToIF to PressForce + PressCheckToIF.
	ForceCheckMode is PressFollow and ForceCheckPolarity is inside: If Fx, Fy, and Fz, the axis specified by Follow in ControlMode is within the range of -FollowCheckToIF to +FollowCheckToIF.
	When ForceCheckMode is PressFollow and ForceCheckPolarity is Outside: In Fx, Fy, and Fz, the axis specified by Follow by ControlMode is outside the range of -FollowCheckToIF to +FollowCheckToIF.
	ForceCheckMode is PressFollow and ForceCheckPolarity is inside: The axis, which is specified to Follow by , ControlMode in Tx, Ty, or Tz: The axis should be within the range of -FollowCheckToIT to +FollowCheckToIT.
	When ForceCheckMode is PressFollow and ForceCheckPolarity is Outside: In Tx, Ty, and Tz, the axis, which is specified Follow by ControlMode is outside the range of -FollowCheckToIT to +FollowCheckToIT.
End conditions related to position	Satisfy either one of the following while the robot moves the specified trajectory:
	When PosCheckType is RobotPlane: Satisfy the state set by PlaneEndCondition for Plane set by PlaneNumber.
	When PosCheckType is RelativePlane: Satisfy the state set by PlaneEndCondition for the relative plane set by PlaneRelativeX, PlaneRelativeY, PlaneRelativeZ, PlaneRelativeOrg, PlaneRelativeOrient, PlaneAxes, PlaneRelativeRobotLocal.
End conditions related to I/O	Input bit specified by IOCheckInputBit should be the state specified by IOCheckInputStatus while the robot moves the specified trajectory.

4.4.2.2.8.1 Property setting guidelines for the PressMove object

Step 1. Set basic information

Set properties (Name, Description, Enabled, StepID, AbortSeqOnFail) related to the basic information.

Properties	Description, setting guide
Name	This property sets names of force guide objects. Set a particular name.
Description	This property sets descriptions about force guide objects. Describe the operations. Set a character string.
Enabled	Set whether to execute the force guide object.
	True : Normal
	False : When you do not execute the force guide object (e.g., when you execute another force guide object instead).
StepID	StepID during the force guide object execution. Set an ID. StepID is an ID which is recorded in the log data. It helps you to understand which log data support a process. It is applied when AutoStepID of the force guide sequence is False.
AbortSeqOnFail	Set whether to abort or continue the force guide sequence when the force guide object fails.
	True : Normal End a force guide sequence.
	False : Cases where the force guide sequence contains recovery operations in case of failure; cases where the sequence will be able to continue even in the event of a failure.

Step 2. Set I/O processing before starting

Set properties (IOPreprocEnabled, IOPreprocOutputBit, IOPreprocOutputStatus) related to I/O processing before starting force guide object.

Properties	Description, setting guide
IOPreprocEnabled	Set whether to operate the output bit when starting the force guide object. You can operate only one output bit. To operate several output bit, use SPELFunc object.
	False : Normal
	True : You operate the output bit, as when you use or stop a peripheral device.
IOPreprocOutputBit	Set the output bit which is operated when the force guide object starts.
IOPreprocOutputStatus	Set whether to turn the output bit ON or OFF when the force guide object starts. Set the state to be output.

Step 3. Set a movement motion

Set properties (MotionTrajectory, AccelS, AccelR, SpeedS, SpeedR, CPEnabled) related to movements.

Properties	Description, setting guide
MotionTrajectory	Set types of trajectory to move.
	Straight : Operates in a straight motion
	Arc : Operates in an arcing motion
	MultiStraight : Operates multiple points successively in a straight motion

Properties	Description, setting guide
	MultiStraightCP : Operates multiple points continuously in a straight motion while linking the trajectory
AccelS AccelR	Set an acceleration of the movement. AccelS: Translational Acceleration AccelR: Rotational rotation acceleration Actual acceleration is adjusted by the force control functions.
SpeedS SpeedR	Set the translational velocity of the movement. SpeedS: Translational Speed SpeedR: Rotational rotation speed Actual speed is adjusted by the force control functions.
SpeedRPriority	Sets whether the SpeedR property is prioritized when moving. When the orientation change between points is large relative to the moving distance, operating with the SpeedS property may result in acceleration errors. AutoDistOrientRatio automatically determines whether to use the SpeedR property based on the moving distance between points and the orientation change. Selecting AutoDistOrientRatio is recommended. Select Disabled or Enabled to fix to the SpeedS or SpeedR property. Disabled: When constantly using the SpeedS property Enabled: When constantly using the SpeedR property
CPEnabled	Sets whether to connect the trajectory of the PressMove object with that of the following force guide object with Path Motion. True : When operating the robot using multiple PressMove objects while connecting their complex trajectories.

Step 4. Set a destination point

Set properties (DestType, DestPoint, MidPoint, RelativeOrient, RelativeRobotLocal, DestRelativeX, ..., DestRelativeW, MidRelativeX, ..., MidRelativeW) related to trajectories to move.

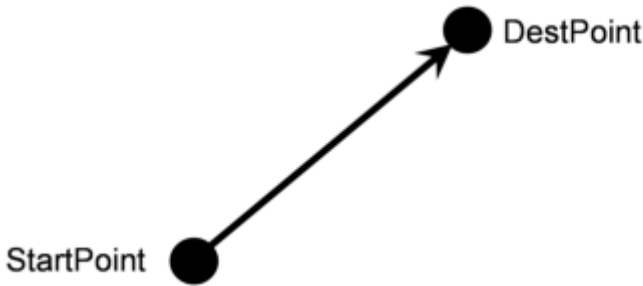
Properties	Description, setting guide
DestType	This property can set how to set a destination point. If you use the force control functions, the robot positions are adjusted by the force. Therefore, we recommend specifying a destination point by a relative movement amount from the positioning point. RobotPoint : When moving to the specified point Relative : When specifying the relative movement amount
DestPoint	Set a point indicating a destination point (DestPoint). When selecting Straight in MotionTrajectory: As shown below, the robot moves in a straight line from the StartPoint of the force guide object to the DestPoint. 

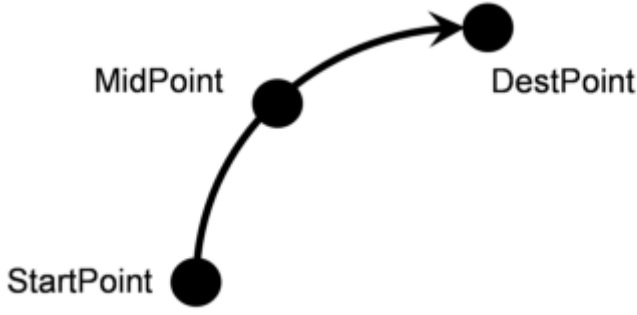
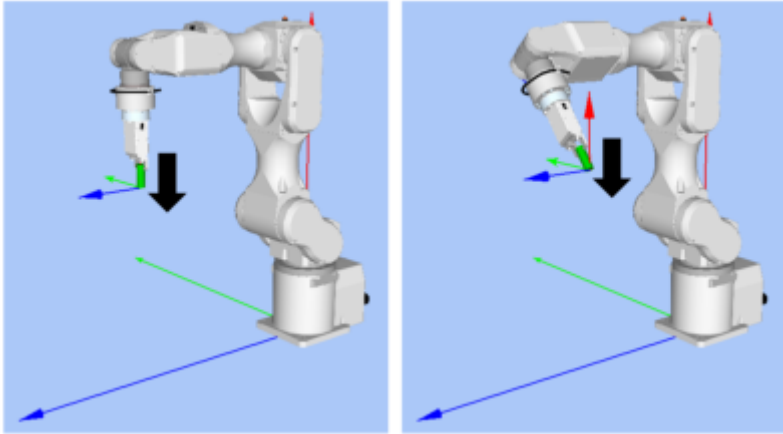
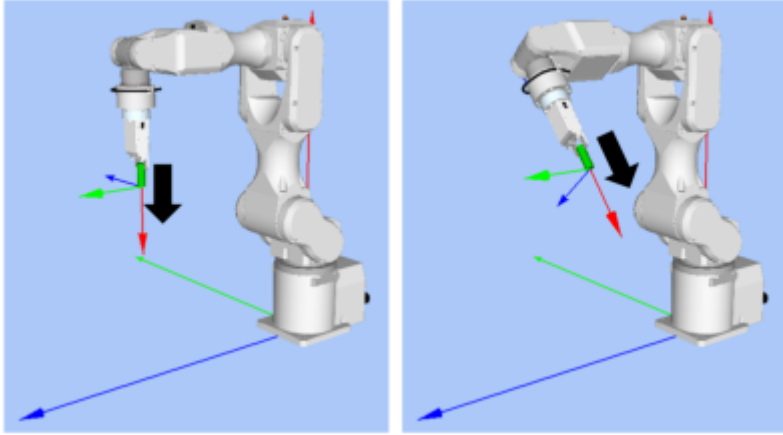
Properties	Description, setting guide
MidPoint	<p>When the MotionTrajectory is Arc, set a point indicating a middle point (MidPoint). As shown below, the robot moves to the DestPoint after passing through the MidPoint.</p>  <p>The diagram illustrates an arc trajectory. It starts at a point labeled 'StartPoint', moves through a point labeled 'MidPoint', and ends at a point labeled 'DestPoint'. A curved arrow indicates the path of the robot's end effector.</p>
RelativeOrient	<p>Set a coordinate system direction which will be a reference of the relative movement.</p> <p>When specifying Base or Local: As viewed from outside, the robot always operates to a defined direction. The following is an example to set Base. When moving to -Z direction, the robot always moves to the vertical-downward (-Z direction in Base coordinate system) even the orientation of end effector changed. (Black arrow is a direction of the robot motion.) If you want to move the robot in a different direction from the Base coordinate system, specify it using the Local coordinate system.</p>  <p>The two images show a robot arm in a 3D coordinate system with red, green, and blue axes. In the left image, a black arrow points vertically downwards, representing the -Z direction in the Base coordinate system. In the right image, the robot arm is rotated, but the black arrow still points vertically downwards, demonstrating that the Base coordinate system's direction is constant regardless of the arm's orientation.</p> <p>When specifying Tool: Movement direction changes along with the orientation at the start. The following is an example to set Tool. When moving to +Z direction, the moving direction changes depending on the orientation of end effector at the start.</p>  <p>The two images show a robot arm in a 3D coordinate system. In the left image, a black arrow points vertically upwards, representing the +Z direction in the Tool coordinate system. In the right image, the robot arm is rotated, and the black arrow now points in a different direction, demonstrating that the Tool coordinate system's direction changes with the orientation of the end effector.</p>

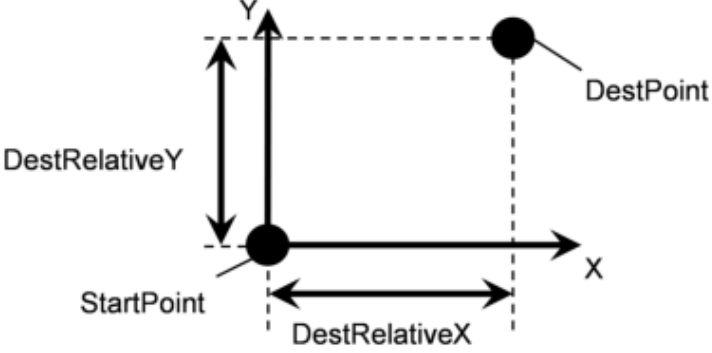
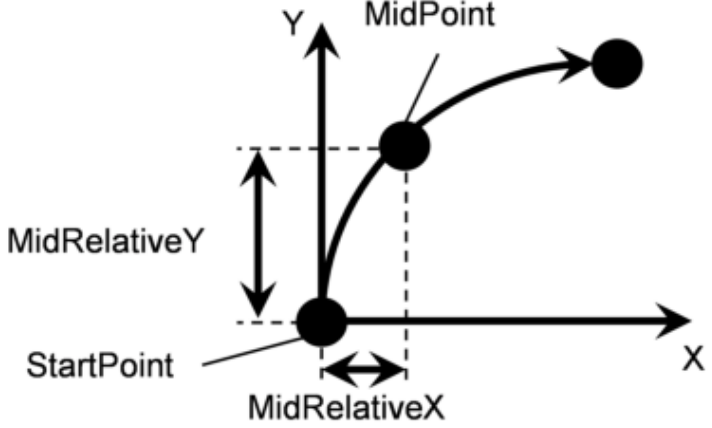
Properties	Description, setting guide
	<p>Base, Local: To move the robot to a defined direction as viewed from outside even the robot orientation at the start of the force guide object is changed.</p> <p>Tool: To move to the direction depending on the robot orientation.</p>
RelativeRobotLocal	Set a Local coordinate system number which is used when specifying Local by RelativeOrient.
DestRelativeX DestRelativeY DestRelativeZ DestRelativeU DestRelativeV DestRelativeW	<p>Set a relative movement amount to each direction from the StartPoint of the force guide object to the DestPoint. As shown below, set a movement amount in the coordinate system specified by RelativeOrient.</p> 
MidRelativeX MidRelativeY MidRelativeZ MidRelativeU MidRelativeV MidRelativeW	<p>Set a relative movement amount to each direction from the StartPoint of the force guide object to the MidPoint. As shown below, set a movement amount in the coordinate system specified by RelativeOrient.</p> 

Properties	Description, setting guide
StartPoint EndPoint	<p>This property sets descriptions of force guide objects.</p> <p>As shown in the figure below, when P1 is set for StartPoint and P3 is set for EndPoint, those will be moved continuously in the order of P1, P2, P3.</p> <p>The diagram illustrates a sequence of three points: StartPoint (labeled P1), P2, and EndPoint (labeled P3). Solid black lines connect P1 to P2, and P2 to P3. An arrowhead is at the end of the line connecting P2 and P3, pointing towards P3. The labels 'StartPoint', 'P1', 'P2', 'P3', and 'EndPoint' are placed near their respective points.</p>

Step 5. Set force control functions

Set properties (Fx_ControlMode, ..., Tz_ControlMode, Fx_PressForce, ..., Tz_PressForce, Fx_Firmness, ..., Tz_Firmness, CFEnabled) related to the force control function.

Properties	Description, setting guide
Fx_ControlMode Fy_ControlMode Fz_ControlMode Tx_ControlMode Ty_ControlMode Tz_ControlMode	<p>Mode of the force control functions to each direction.</p> <p>Press+: The robot moves to a positive direction of each axis and presses.</p> <p>Press -: The robot moves in a negative direction on each axis and presses.</p> <p>When specifying Follow:</p> <p>Perform the follow motion by the force control functions.</p> <p>When specifying Disabled:</p> <p>Force control functions are disabled.</p> <p>Set the ControlMode in pressing direction to Press+ or Press-.</p> <p>Set ControlMode where you want to follow to Follow.</p> <p>One or more directions must be set to a status other than Disabled.</p>
Fx_PressForce Fy_PressForce Fz_PressForce Tx_PressForce Ty_PressForce Tz_PressForce	<p>Set the force and torque set to each direction.</p> <p>It is used when ControlMode is Press+ or Press-</p> <p>When ControlMode is Press+:</p> <p>Set a negative value.</p> <p>When ControlMode is Press-:</p> <p>Set a positive value.</p> <p>For fittings or assembly tasks, the force is usually set from 3 to 5[N] or from -3 to -5[N] in Fx, Fy, and Fz. However, a proper value differs depending on tasks or workpiece.</p>
Fx_Firmness Fy_Firmness Fz_Firmness Tx_Firmness Ty_Firmness Tz_Firmness	<p>Set a firmness of the force control functions to each direction.</p> <p>When setting a large value:</p> <p>The Force Control functions become stronger, but response to changes in force is slow.</p> <p>When setting a small value:</p> <p>The Force Control function will become weaker. Response to changes in force is fast; however, vibrations can easily occur.</p>

Properties	Description, setting guide
CFEnabled	Set whether to continue the force control functions to the next force guide object. False : Normal Turn OFF the force control functions once, then execute the next force guide object. True : When you want to start the next force guide object, and keep the force constant after contact with the prior object.

You can check the settings of ControlMode by a simulator.

A coordinate system with grayed out except the enabled direction is displayed. However, the robot is displayed based on the current position. When you check the settings, make sure to move the robot to the position where executing the force guide object.

For details on how to check by using simulator, refer to the following manual.

"Epson RC+ 8.0 User's Guide: - Simulator - Description of Functions"

Step 6. Set basic information for end conditions

Set a property (EndCheckOperator) related to combinations of end conditions.

Properties	Description, setting guide
EndCheckOperator	This property sets how to combine the end conditions related to force, position, and I/O.
	AND : End when all conditions to be used are satisfied.
	OR: End when one or more conditions is satisfied.

Step 7. Set end conditions related to force

Set properties (ForceCheckEnabled, ForceCheckMode, ForceCheckPolarity, PressCheckToIF, PressCheckToIT, FollowCheckToIF, FollowCheckToIT, HoldTimeThresh) related to the end conditions of force.

Properties	Description, setting guide
ForceCheckEnabled	This property sets whether to enable the end conditions of force. True : When enabling the end conditions related to force.
ForceCheckMode	Target direction of determination.
	Press : Only the pressing direction is evaluated. Directions (Press+, Press-) specified by ControlMode are evaluated.
	PressFollow : The pressing direction and follow direction are evaluated. Directions (Press+, Press-, Follow) specified by ControlMode are evaluated.
ForceCheckPolarity	Polar of the end conditions related to force.
	Inside : Normally set. Being inside of the specified range is an end condition.
	Outside : Being outside of the specified range is an end condition. Use Outside when using a special end condition such as starting with the pressing state and making it as an end condition that the pressing state is released.

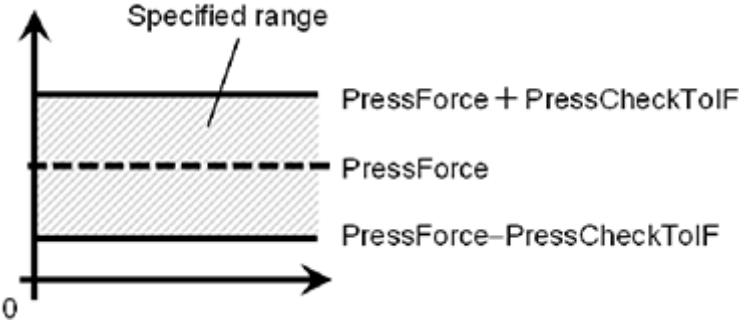
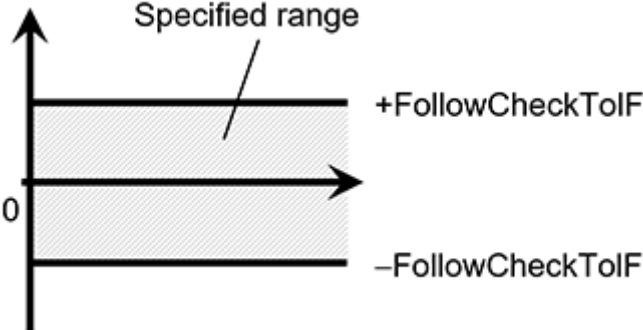
Properties	Description, setting guide
<p>PressCheckToF PressCheckToT</p>	<p>This property sets the pressing direction range of the end conditions related to force. Set a range of the end conditions. PressCheckToF is applied for Fx, Fy, and Fz. PressCheckToT is applied for Tx, Ty, and Tz. It monitors that the force of directions (Press+, Press-) specified by ControlMode of Fx, Fy, and Fz are within the range of PressForce -PressCheckToF to PressForce +PressCheckToF. It monitors that the torque of the force directions (Press+, Press-) specified by ControlMode of Tx, Ty, and Tz is within the range of PressForce -PressCheckToT to PressForce +PressCheckToT. The following is an image of PressCheckToF.</p> 
<p>FollowCheckToF FollowCheckToT</p>	<p>This property sets the range in the follow direction of the end conditions related to force. FollowCheckToF is applied for Fx, Fy, and Fz, FollowCheckToT is applied for Tx, Ty, and Tz It monitors that the force of directions specified to Follow by ControlMode of Fx, Fy, and Fz are within the range of -FollowCheckToF to +FollowCheckToF. It monitors that the torque of directions specified to Follow by ControlMode of Tx, Ty, and Tz are within the range of -FollowCheckToT to +FollowCheckToT. The following is an image of InsertCheckToF.</p> 
<p>HoldTimeThresh</p>	<p>Set the duration time which is used to determine whether the end conditions have satisfied. As shown below, if the specified condition continues for the time specified by HoldTimeThresh, it is determined as the end conditions are satisfied.</p>

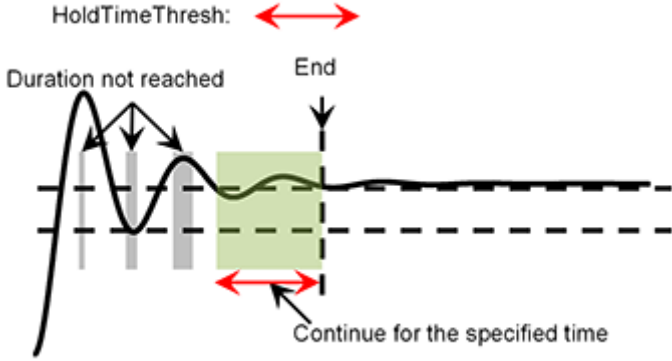
Properties	Description, setting guide
	<div style="text-align: center;">  </div> <p>Normally, set to "0". Set the time for stabilizing the motion when the results of the next force guide object are unstable. We recommend setting the time according to the actual result which is executed after temporarily disabling the end conditions.</p>

Step 8. Set end conditions about position

Set properties (PosCheckEnabled, PosCheckType, PlaneNumber, PlaneEndCond, PlaneRelativeOrg, PlaneRelativeX, PlaneRelativeY, PlaneRelativeZ, PlaneRelativeOrient, PlaneAxes, PlaneRelativeRobotLocal) related to the end conditions of the positions.

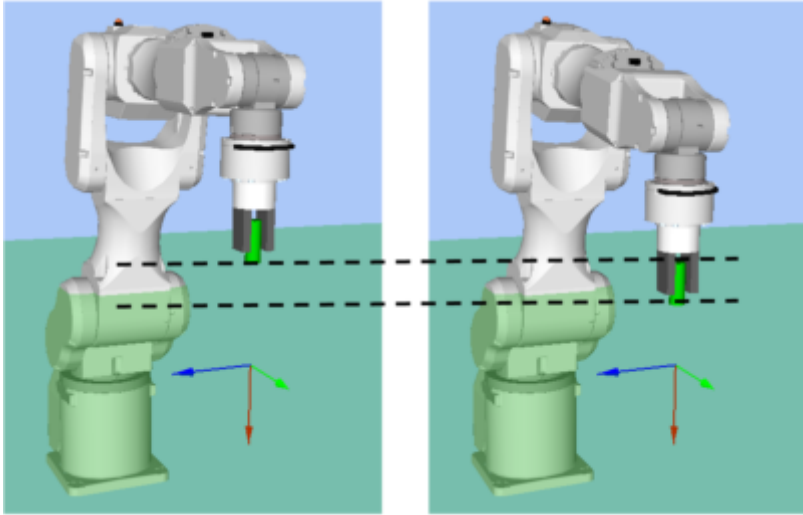
Properties	Description, setting guide
PosCheckEnabled	This property sets whether to enable the end conditions of positions.
	True : When the end conditions related to position are enabled.
	False : When the end conditions related to position are disabled.
PosCheckType	Select types of the end conditions related to positions.
	<p>When selecting RobotPlane: End conditions are based on the set Plane. As shown below, use this property for setting the end conditions based on a defined position regardless of the position of the robot.</p> <div style="text-align: center;">  </div> <p>When selecting RelativePlane: Every time the force guide sequence is executed, create Plane at a relative position from the current position and set as an end condition of position.</p>

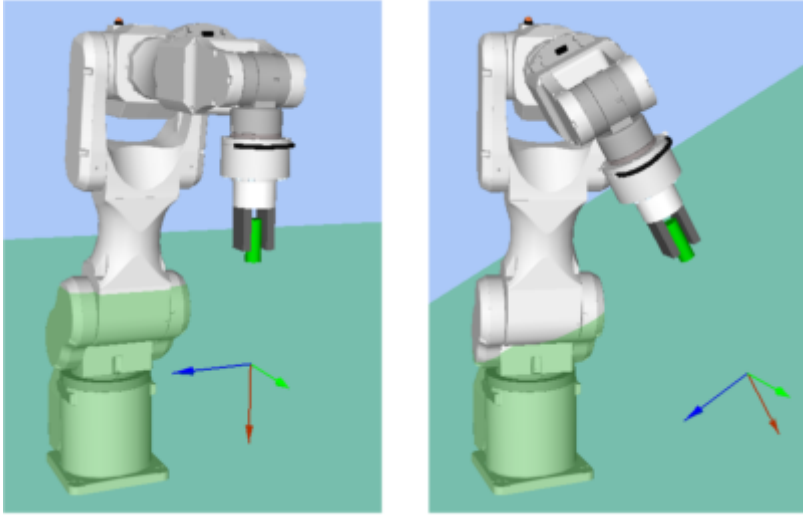
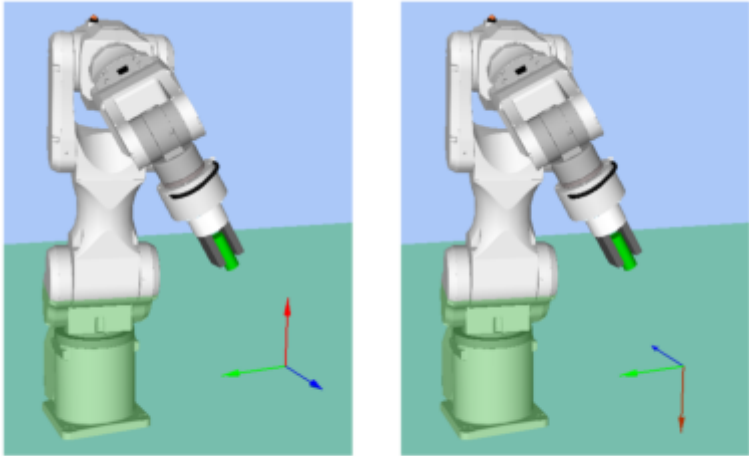
Properties	Description, setting guide
	<p>As shown below, use this property for changing the end condition positions depending on the position at the start.</p> 
PlaneNumber	<p>Set Plane number which is used for an end condition of positions.</p> <p>When PosCheckType is RobotPlane: End conditions based on the specified Plane number are set.</p> <p>When PosCheckType is RelativePlane: Every time the force guide sequence is executed, set Plane to the specified number. Set an empty Plane number.</p>
PlaneEndCond	<p>Set the state of the end condition of positions. Set either Inside (inside the Plane) or Outside (outside of the Plane) as an end condition. When the robot will be the specified state, it is determined as the end conditions of the positions are satisfied.</p> <p>Inside the plane: It is in +Z direction of Plane.</p>  <p style="text-align: center;">Inside Outside</p>

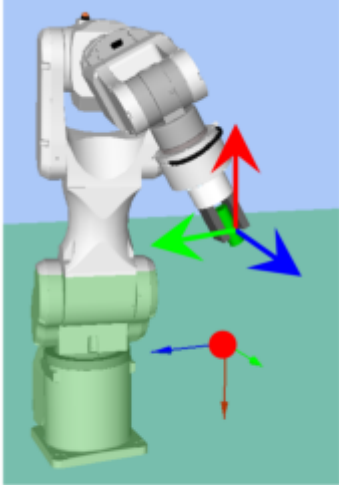
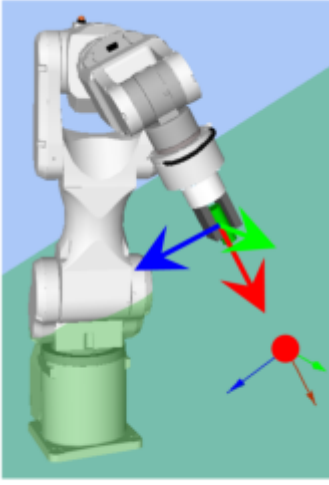
Properties	Description, setting guide
<p>PlaneRelativeOrg</p>	<p>Set which coordinate system direction is used as a reference when expressing the offset amount to the origin of Plane.</p> <p>The left figure below is an example to set Base.</p> <p>Specify a relative distance based on the Base coordinate system.</p> <p>It is an example that the negative value is set in PlaneRelativeZ.</p> <p>The right figure below is an example to set Tool.</p> <p>Specify a relative distance based on the Tool coordinate system.</p> <p>It is an example that the positive value is set in PlaneRelativeZ.</p> <div style="display: flex; justify-content: space-around; align-items: center;">   </div> <div style="display: flex; justify-content: space-around; margin-top: 10px;"> Base Tool </div> <p>The Local or Tool coordinate systems are used only in that direction and origin position does not affect.</p> <p>To set the position of an end condition in the robot motion direction, normally set the same value as ForceOrient of the force guide sequence.</p>
<p>PlaneRelativeX PlaneRelativeY PlaneRelativeZ</p>	<p>Set offset amount in each direction from the current position to the origin of Plane.</p> <p>Direction will be the coordinate system direction specified by PlaneRelativeOrg.</p>
<p>PlaneRelativeOrient</p>	<p>Set a coordinate system based on the Plane direction.</p> <p>The left figure below is an example to set Base.</p> <p>Reference direction of the Plane matches the Base coordinate system regardless of the robot orientation at the start of the force guide object.</p> <p>The right figure below is an example to set Tool.</p> <p>Reference direction of the Plane changes along with the robot orientation at the start of the force guide object.</p>

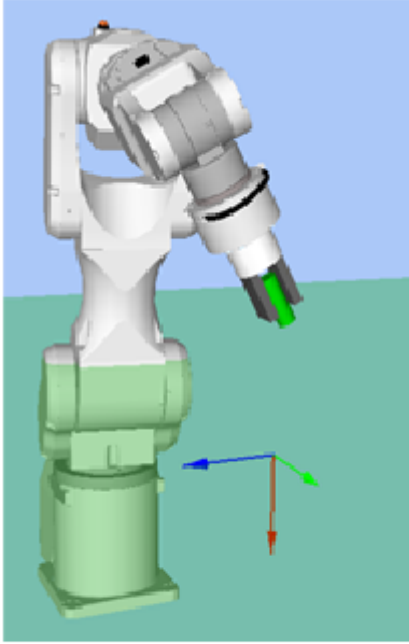
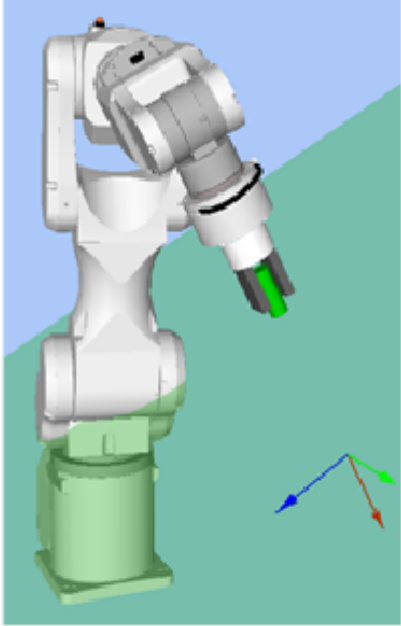
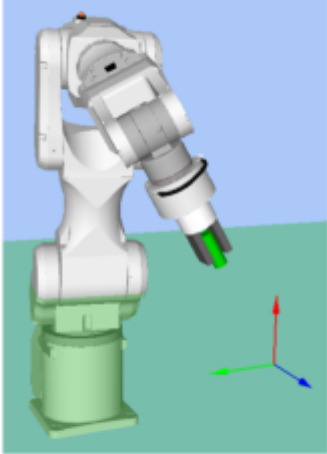
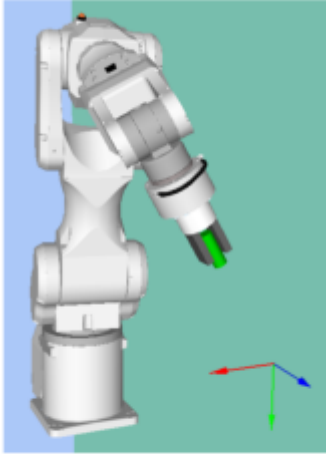
Properties	Description, setting guide
	<div style="display: flex; justify-content: space-around; align-items: center;"> <div style="text-align: center;">  <p>Ex. to set Base</p> </div> <div style="text-align: center;">  <p>Ex. to set Tool</p> </div> </div> <p>Since a plane which is perpendicular to the robot motion direction will be the end conditions, normally set the same value as ForceOrient of the force guide sequence.</p>
PlaneAxes	<p>Set a Plane direction Based on the coordinate system specified by PlaneRelativeOrient, plane is set to a direction set by PlaneAxes. The following figure is an example when Base is set by PlaneRelativeOrient. Left figure: XY is specified by PlaneAxes. Right figure: YZ is specified by PlaneAxes.</p> <div style="display: flex; justify-content: space-around; align-items: center;"> <div style="text-align: center;">  <p>XY</p> </div> <div style="text-align: center;">  <p>YZ</p> </div> </div> <p>Normally, set Plane which is perpendicular to the robot motion direction.</p>
PlaneRelativeRobotLocal	<p>Set Local coordinate system number which is used when PlaneRelativeOrg and PlaneRelativeOrient are Local. Normally, set a value which is the same as RobotLocal of the force guide sequence.</p>

Step 9. Set end conditions related to I/O

Set properties (IOCheckEnabled, IOCheckInputBit, IOCheckInputStatus) related to the end conditions of I/O.

Properties	Description, setting guide
IOCheckEnabled	This property sets whether to enable the end conditions of I/O. True : When the end conditions related to I/O are enabled.
IOCheckInputBit	Set an input bit which is monitored as an end condition.
IOCheckInputStatus	Set a state of the input bit to be an end condition. If the input bit specified by IOCheckInputBit will be the state specified by IOCheckInputStatus, it is determined as the end conditions are satisfied.

4.4.2.2.8.2 Adjustment guidelines for the PressMove object

The following describes the ways you can make adjustments when using the PressMove object.

- When the robot motion vibrates:
Increase the Firmness value. However, response of the robot will be slow. Please perform proper adjustments for your operations.
To adjust the Firmness, we recommend changing the value gradually (e.g. increase the value by 10% from its present state).
- When the robot bounces largely in the pressing direction:
If the robot repeatedly bounces largely in a few seconds, the robot motion may be restricted by LimitAccelS of the force guide sequence.
Also, it likely to happen during the execution in low power mode.
If the robot still bounces even executing in high power mode, increase the value of LimitAccelS. If the robot still bounces, decrease the value of Firmness in pressing direction.
- When the robot does not reach to the target force:
Decrease the Firmness value of the pressing direction.
However, the robot motion may be easy to vibrate. Please perform proper adjustments for your operations.
To adjust the Firmness, we recommend changing the value gradually (e.g. decrease the value by 10% from its current state).
- When the robot does not move to the pressing direction:
Confirm that the ControlMode where the robot does not move is either Press+ or Press-.
When Press+ or Press- is set, confirm whether the PressForce is set to "0".
- When the robot moves in the reverse direction:
Confirm that the ControlMode where the robot moves in the reverse direction is either Press+ or Press-.
When the robot is set to assumed direction, confirm the ForceOrient or RobotLocal of the force guide sequence, tool coordinate system, or local coordinate system.
- When the robot does not reach to the destination point:
If the direction where the force control functions are not enabled is not reached to the destination point, it may be affected by the LimitAccel or LimitSpeed of the force guide sequence. Increase the value.
Also, in low power mode, it is restricted according to the maximum speed or maximum acceleration of the low power mode even the value of LimitSpeed or LimitAccel is large. Be sure to execute in high power mode.

4.4.2.2.8.3 Details on the properties of the PressMove object

- Name Property
This property sets a particular name that is assigned to force guide object.

When creating a PressMove object, the name is assigned automatically. Automatically assigned name is added a number after PressMove (e.g. PressMove01).

You can change the name. Set up 16 characters at the maximum. Please use alphanumeric characters and underscores [_].

Note: The initial character cannot be a numeric character.

■ Description Property

This property sets descriptions about force guide objects.

You can set the character string up to 255 characters.

■ Enabled Property

This property sets whether to enable force guide objects.

When specifying True, the force guide object is executed.

When specifying False, execute the next force guide object without executing the force guide object.

Use this property when you want to save the force guide sequence temporary or try with different parameters by copying the force guide object during the force guide sequence creation.

Value	Description
True	Enable a force guide object.
False	Disable a force guide object.

Default: True

■ StepID Property

This property sets StepID during the execution of the force guide objects.

It is only used when AutoStepID is False.

	Value
Minimum Value	0
Maximum value	32767

Default: Automatically set according to the numbers of the force guide sequence and the force guide object.

■ AbortSeqOnFail Property

This property sets operations when force guide object fails.

When True is specified: If the force guide object fails, the program ends the force guide sequence and proceeds to the next SPEL statement.

When specifying False: If force guide object fails, the program proceeds to the next force guide object without ending the force guide sequence.

Use this property when you want to continue the force guide sequence (e.g. the recovery processes are included in the force guide sequence when the force guide object fails.)

Value	Description
True	Abort the force guide sequence when the force guide object fails.
False	Start the next force guide sequence when the force guide object fails.

Default: True

■ IOPreprocEnabled Property

This property sets I/O operations when the force guide object starts.

I/O operations are defined by IOPreprocOutputBit Property and IOPreprocOutputStatus Property. Use this property when you want to operate the hands or peripherals before the force guide object execution.

Value	Description
True	Execute I/O operation at the start.
False	I/O operation at the start is not executed.

Default: False

■ IOPreprocOutputBit Property

This property sets I/O operations (output bit) when the force guide object starts.

It is only used when IOPreprocEnabled is True.

	Value
Minimum Value	0
Maximum value	7167

Default: 0

■ IOPreprocOutputStatus Property

This property sets the output state of I/O operations when the force guide object starts.

It is only used when IOPreprocEnabled is True.

Value	Description
Off	Turn OFF (set to 0) the specified output bit.
On	Turn ON (set to 1) the specified output bit.

Default: Off

■ MotionTrajectory Property

This property sets trajectory for force guide objects.

Value	Description
Straight	Moves in a straight trajectory.
Arc	Moves in an arcing trajectory.
MultiStraight	Moves multiple points continuously in a straight motion.
MultiStraightCP	Moves multiple points continuously in a straight motion while linking the trajectory.

Default: Straight

■ AccelS Property

This property sets acceleration of force guide objects.

However, this set value is the acceleration for the set trajectory. The actual acceleration is adjusted by the force control functions.

	Value (unit: [mm/sec ²])
Minimum Value	1
Maximum value	200

Default: 50

■ AccelR Property

This property sets rotation acceleration of force guide objects during the execution.

However, this set value is the rotation acceleration for the set trajectory. The actual rotation acceleration is adjusted by the force control functions.

	Value (unit: [deg/sec ²])
Minimum Value	1
Maximum value	100

Default: 10

▪ SpeedS Property

This property sets speed of force guide objects during the execution.

However, this set value is the speed for the set trajectory. The actual speed is adjusted by the force control functions.

	Value (unit: [mm/sec])
Minimum Value	1
Maximum value	200

Default: 50

▪ SpeedR Property

This property sets rotation speed of force guide objects during the execution.

However, this set value is the rotation speed for the set trajectory. The actual rotation speed is adjusted by the force control functions.

	Value (unit: [deg/sec ²])
Minimum Value	1
Maximum value	25

Default: 10

▪ SpeedRPriority Property

This property sets whether to prioritize tool orientation changes during force guide object execution.

When prioritizing tool orientation changes: The robot moves using the SpeedR property.

When not prioritizing tool orientation changes: The robot moves using the SpeedS property.

The following values can be specified:

Value	Description
Disabled	When the moving distance is not 0, executes the force guide object using the SpeedS property. When the moving distance is 0, uses the SpeedR property. - Does not give priority to the tool orientation changes. - Gives priority to the SpeedS property.
Enabled	When the orientation change is not 0, executes the force guide object using the SpeedR property. When the orientation change is 0, uses the SpeedS property. - Gives priority to the tool orientation changes. - Gives priority to the SpeedR property.
AutoDistOrientRatio	Executes the force guide object by automatically determining whether to give priority to the SpeedR property based on the moving distance and the orientation change.

Default: AutoDistOrientRatio

▪ CPEnabled Property

Set enable/disable the path motion.

Use this property to synthesize the trajectory for multiple force guide objects with movement.

When specifying True, path motion is enabled and the program starts the next force guide object when entering into the slowdown zone.

When specifying False, path motion is disabled and the program starts the next force guide object after the set trajectory ends.

However, if the end conditions are set and achieved, the program pauses once when they are achieved and proceeds to the next force guide object.

Value	Description
True	Enable the path motion.
False	Disable the path motion.

Default: False

▪ DestType Property

This property sets the method to specify a destination point of the trajectory.

When specifying RobotPoint, set the destination point on by point.

When specifying Relative, set a relative distance (e.g. 10mm from the start point in the X direction).

Value	Description
RobotPoint	Set a point as the destination.
Relative	Set a destination position by relative distance.

Default: RobotPoint

▪ DestPoint Property

This property sets the point used as the destination point of the trajectory.

It is used when specifying RobotPoint in DestType.

	Value
Minimum Value	0
Maximum value	999

Default: 0

▪ MidPoint Property

This property sets the midpoint used for the arc trajectory.

It is used when specifying Arc in MotionTrajectory and RobotPoint in DestType.

	Value
Minimum Value	0
Maximum value	999

Default: 0

▪ RelativeOrient Property

This property sets the coordinate system that moves relatively.

It is used when specifying Relative in DestType.

Value	Description
Base	Specify a relative distance based on the Base coordinate system.
Local	Specify a relative distance based on the Local coordinate system.
Tool	Specify a relative distance based on the Tool coordinate system.

Default: Tool

▪ RelativeRobotLocal Property

This property sets the number of local coordinate system for the coordinate system that moves relatively. It is used when specifying Relative in DestType and Local in RelativeOrient.

Value	Description
0 (Base)	Use the Local 0 coordinate system (Base coordinate system). It is the same as when specifying Base in RelativeOrient
1 to 15	Use the Local coordinate system of the specified number.

Default: 0 (Base)

▪ DestRelativeX Property

For the destination point, this property sets the moving amount in X direction of coordinate systems specified by RelativeOrient and RelativeRobotLocal.

It is used when specifying Relative in DestType.

	Value (Unit: [mm])
Minimum Value	-2000
Maximum value	2000

Default: 0

▪ DestRelativeY Property

For the destination point, this property sets the moving amount in Y direction of coordinate systems specified by RelativeOrient and RelativeRobotLocal.

It is used when specifying Relative in DestType.

	Value (Unit: [mm])
Minimum Value	-2000
Maximum value	2000

Default: 0

▪ DestRelativeZ Property

For the destination point, this property sets the moving amount in Z direction of coordinate systems specified by RelativeOrient and RelativeRobotLocal.

It is used when specifying Relative in DestType.

	Value (Unit: [mm])
Minimum Value	-2000
Maximum value	2000

Default: 0

▪ DestRelativeU Property

For the destination point, this property sets the rotation amount in U direction of coordinate systems specified by RelativeOrient and RelativeRobotLocal.

It is used when specifying Relative in DestType.

	Value (unit: [deg])
Minimum Value	-360
Maximum value	360

Default: 0

▪ DestRelativeV Property

For the destination point, this property sets the rotation amount in V direction of coordinate systems specified by RelativeOrient and RelativeRobotLocal.

It is used when specifying Relative in DestType.

	Value (unit: [deg])
Minimum Value	-360
Maximum value	360

Default: 0

▪ DestRelativeW Property

For the destination point, this property sets the rotation amount in W direction of coordinate systems specified by RelativeOrient and RelativeRobotLocal.

It is used when specifying Relative in DestType.

	Value (unit: [deg])
Minimum Value	-360
Maximum value	360

Default: 0

▪ MidRelativeX Property

For the mid-point, this property sets the moving amount in X direction of coordinate systems specified by RelativeOrient and RelativeRobotLocal.

It is used when specifying Arc in MotionTrajectory and Relative in DestType.

	Value (Unit: [mm])
Minimum Value	-2000
Maximum value	2000

Default: 0

▪ MidRelativeY Property

For the mid-point, this property sets the moving amount in Y direction of coordinate systems specified by RelativeOrient and RelativeRobotLocal.

It is used when specifying Arc in MotionTrajectory and Relative in DestType.

	Value (Unit: [mm])
Minimum Value	-2000
Maximum value	2000

Default: 0

▪ MidRelativeZ Property

For the mid-point, this property sets the moving amount in Z direction of coordinate systems specified by RelativeOrient and RelativeRobotLocal.

It is used when specifying Arc in MotionTrajectory and Relative in DestType.

	Value (Unit: [mm])
Minimum Value	-2000
Maximum value	2000

Default: 0

▪ MidRelativeU Property

For the mid-point, this property sets the rotating amount in U direction of coordinate systems specified by RelativeOrient and RelativeRobotLocal.

It is used when specifying Arc in MotionTrajectory and Relative in DestType.

	Value (unit: [deg])
Minimum Value	-360
Maximum value	360

Default: 0

▪ MidRelativeV Property

For the mid-point, this property sets the rotating amount in V direction of coordinate systems specified by RelativeOrient and RelativeRobotLocal.

It is used when specifying Arc in MotionTrajectory and Relative in DestType.

	Value (unit: [deg])
Minimum Value	-360
Maximum value	360

Default: 0

▪ MidRelativeW Property

For the mid-point, this property sets the rotating amount in W direction of coordinate systems specified by RelativeOrient and RelativeRobotLocal.

It is used when specifying Arc in MotionTrajectory and Relative in DestType.

	Value (unit: [deg])
Minimum Value	-360
Maximum value	360

Default: 0

▪ StartPoint Property

This property sets the start position of the continuous moving trajectory.

Used when specifying MultiStraight or MultiStraightCP in MotionTrajectory.

	Value
Minimum Value	0
Maximum value	999

Default: 0

▪ EndPoint Property

This property sets the end position of the continuous moving trajectory.

Used when specifying MultiStraight or MultiStraightCP in MotionTrajectory.

	Value
Minimum Value	0
Maximum value	999

Default: 0

▪ Fx_ControlMode Property

Set the control mode in Fx direction in the coordinate system specified by ForceOrient of the force guide sequence.

When specifying Disabled, the force control functions to Fx direction are not executed.

When specifying Press+ or Press-, the force control function in the Fx direction is executed in the press mode. In the press mode, the robot presses so as to become the force specified by Fx_PressForce.

When specifying Follow, the force control functions to Fx direction is executed as the follow mode. In the follow mode, the robot moves so that the external force will be "0". Therefore, when the external force is applied, the robot moves to follow it.

Value	Description
Disabled	Disable the force control functions.
Press+	The force control functions are executed to press in the positive direction.
Press-	The force control functions are executed to press in the negative direction.
Follow	The force control functions are executed to perform the Follow motion.

Default: Disabled

■ Fx_PressForce Property

This property sets pressing force to Fx direction during the execution of force guide objects. It is used when Fx_ControlMode is Press+ or Press-

- When ControlMode is Press+:

	Value (unit: [N])
Minimum Value	-250
Maximum value	0

Default: 0

- When ControlMode is Press-

	Value (unit: [N])
Minimum Value	0
Maximum value	250

Default: 0

■ Fx_Firmness Property

This property sets a firmness of force control functions in Fx direction during the execution of force guide object.

It is used when Fx_ControlMode is Press+, Press-, or Follow

When the value of Fx_Firmness increases, the force control function in the Fx direction will become stronger. Response to changes in force is slow; however, vibration rarely occurs.

When Fx_Firmness decreases, the force control function in the Fx direction will become weaker. Response to changes in force becomes faster; however, vibrations easily occur.

	Value
Minimum Value	0.1
Maximum value	200

Default: 10

■ Fy_ControlMode Property

Set the control mode in Fy direction in the coordinate system specified by ForceOrient of the force guide sequence.

When specifying Disabled, the force control functions to Fy direction are not executed.

When specifying Press+ or Press-, the force control function in the Fy direction is executed in the press mode. In the press mode, the robot presses so as to become the force specified by Fy_PressForce.

When specifying Follow, the force control functions to Fy direction is executed as the follow mode. In the follow mode, the robot moves so that the external force will be "0". Therefore, when the external force is applied, the robot moves to follow it.

Value	Description
Disabled	Disable the force control functions.
Press+	The force control functions are executed to press in the positive direction.
Press-	The force control functions are executed to press in the negative direction.
Follow	The force control functions are executed to perform the Follow motion.

Default: Disabled

■ Fy_PressForce Property

This property sets pressing force to Fy direction during the execution of force guide objects. It is used when Fy_ControlMode is Press+ or Press-

- When ControlMode is Press+:

	Value (unit: [N])
Minimum Value	-250
Maximum value	0

Default: 0

- When ControlMode is Press-

	Value (unit: [N])
Minimum Value	0
Maximum value	250

Default: 0

■ Fy_Firmness Property

This property sets a firmness of force control functions in Fy direction during the execution of force guide object.

It is used when Fy_ControlMode is Press+, Press-, or Follow.

When the value of Fy_Firmness increases, the force control function in Fy direction will become stronger. Response to changes of the force is slow, however, vibration hardly occurs.

When Fy_Firmness decreases, the force control function in Fy direction will become weaker. Response to changes of the force is fast, however, vibration is easy to occur.

	Value
Minimum Value	0.1
Maximum value	200

Default: 10

■ Fz_ControlMode Properties

Set the control mode in Fz direction in the coordinate system specified by ForceOrient of the force guide sequence.

When specifying Disabled, the force control functions to Fz direction are not executed.

When specifying Press+ or Press-, the force control function in the Fz direction is executed in the press mode. In the press mode, the robot presses so as to become the force specified by Fz_PressForce.

When specifying Follow, the force control functions to Fz direction is executed as the follow mode. In the follow mode, the robot moves so that the external force will be "0". Therefore, when the external force is applied, the robot moves to follow it.

Value	Description
Disabled	Disable the force control functions.
Press+	The force control functions are executed to press in the positive direction.
Press-	The force control functions are executed to press in the negative direction.
Follow	The force control functions are executed to perform the Follow motion.

Default: Disabled

■ Fz_PressForce Property

This property sets pressing force to Fz direction during the execution of force guide objects. It is used when Fz_ControlMode is Press+ or Press-

- When ControlMode is Press+:

	Value (unit: [N])
Minimum Value	-250
Maximum value	0

Default: 0

- When ControlMode is Press-

	Value (unit: [N])
Minimum Value	0
Maximum value	250

Default: 0

■ Fz_Firmness Property

This property sets a firmness of force control functions in Fz direction during the execution of force guide object. It is used when Fz_ControlMode is Press+, Press- or Follow.

When the value of Fz_Firmness increases, the force control function in Fz direction will become stronger. Response to changes in force is slow; however, vibration rarely occurs.

When Fz_Firmness decreases, the force control function in Fz direction will become weaker. Response to changes of the force is fast, however, vibration is easy to occur.

	Value
Minimum Value	0.1
Maximum value	200

Default: 10

■ Tx_ControlMode Property

Set the control mode in Tx direction in the coordinate system specified by ForceOrient of the force guide sequence.

When specifying Disabled, the force control functions in the Tx direction are not executed.

When specifying Press+ or Press-, the force control function in the Tx direction is executed in the press mode. In the press mode, the robot presses so as to become the force specified by Tx_PressForce.

When specifying Follow, the force control functions to Tx direction is executed as the follow mode. In the follow mode, the robot moves so that the external torque will be "0". Therefore, when the external torque is applied, the robot moves to follow it.

Value	Description
Disabled	Disable the force control functions.
Press+	The force control functions are executed to press in the positive direction.
Press-	The force control functions are executed to press in the negative direction.
Follow	The force control functions are executed to perform the Follow motion.

Default: Disabled

▪ Tx_PressForce Property

This property sets pressing force to Tx direction during the execution of force guide objects. It is used when Tx_ControlMode is Press+ or Press-

- When ControlMode is Press+:

	Value (unit: [N · mm])
Minimum Value	-18000
Maximum value	0

Default: 0

- When ControlMode is Press-

	Value (unit: [N · mm])
Minimum Value	0
Maximum value	18000

Default: 0

▪ Tx_Firmness Property

This property sets a firmness of force control functions in Tx direction during the execution of force guide object.

It is used when Tx_ControlMode is Press+, Press-, or Follow.

When the value of Tx_Firmness increases, the force control function in Tx direction will become stronger. Response to changes of the torque is slow, however, vibration hardly occurs.

When Tx_Firmness decreases, the force control function to Tx direction will become weaker. Response to changes of the torque is fast, however, vibration is easy to occur.

	Value
Minimum Value	10
Maximum value	1000000

Default: 3000

▪ Ty_ControlMode Property

Set the control mode in Ty direction in the coordinate system specified by ForceOrient of the force guide sequence.

When specifying Disabled, the force control functions in the Ty direction are not executed.

When specifying Press+ or Press-, the force control function in the Ty direction is executed in the press mode. In the press mode, the robot presses so as to become the force specified by Ty_PressForce.

When specifying Follow, the force control functions to Ty direction is executed as the follow mode. In the follow mode, the robot moves so that the external torque will be "0". Therefore, when the external torque is applied, the robot moves to follow it.

Value	Description
Disabled	Disable the force control functions.
Press+	The force control functions are executed to press in the positive direction.
Press-	The force control functions are executed to press in the negative direction.
Follow	The force control functions are executed to perform the Follow motion.

Default: Disabled

▪ Ty_PressForce Property

This property sets pressing force to Ty direction during the execution of force guide objects. It is used when Ty_ControlMode is Press+ or Press-

- When ControlMode is Press+:

	Value (unit: [N · mm])
Minimum Value	-18000
Maximum value	0

Default: 0

- When ControlMode is Press-

	Value (unit: [N · mm])
Minimum Value	0
Maximum value	18000

Default: 0

▪ Ty_Firmness Property

This property sets a firmness of force control functions in Ty direction during the execution of force guide object.

It is used when Ty_ControlMode is Press+, Press-, or Follow.

When the value of Ty_Firmness increases, the force control function in Ty direction will become stronger. Response to changes of the torque is slow, however, vibration hardly occurs.

When Ty_Firmness decreases, the force control function to Ty direction will become weaker. Response to changes of the torque is fast, however, vibration is easy to occur.

	Value
Minimum Value	10
Maximum value	1000000

Default: 3000

▪ Tz_ControlMode Property

Set the control mode in Tz direction in the coordinate system specified by ForceOrient of the force guide sequence.

When specifying Disabled, the force control functions to Tz direction are not executed.

When specifying Press+ or Press-, the force control function in the Tz direction is executed in the press mode. In the press mode, the robot presses so as to become the force specified by Tz_PressForce.

When specifying Follow, the force control functions to Tz direction is executed as the follow mode. In the follow mode, the robot moves so that the external torque will be "0". Therefore, when the external torque is applied, the robot moves to follow it.

Value	Description
Disabled	Disable the force control functions.
Press+	The force control functions are executed to press in the positive direction.
Press-	The force control functions are executed to press in the negative direction.
Follow	The force control functions are executed to perform the Follow motion.

Default: Disabled

■ Tz_PressForce Property

This property sets pressing force to Tz direction during the execution of force guide objects. It is used when Tz_ControlMode is Press+ or Press-.

- When ControlMode is Press+:

	Value (unit: [N · mm])
Minimum Value	-18000
Maximum value	0

Default: 0

- When ControlMode is Press-

	Value (unit: [N · mm])
Minimum Value	0
Maximum value	18000

Default: 0

■ Tz_Firmness Property

This property sets a firmness of force control functions in Tz direction during the execution of force guide object.

It is used when Tz_ControlMode is Press+, Press-, or Follow.

When the value of Tz_Firmness increases, the force control function in Tz direction will become stronger. Response to changes of the torque is slow, however, vibration hardly occurs.

When Tz_Firmness decreases, the force control function to Tz direction will become weaker. Response to changes of the torque is fast, however, vibration is easy to occur.

	Value
Minimum Value	10
Maximum value	1000000

Default: 3000

■ CFEnabled Property

This property sets whether to continue the force control functions after the force guide object is ended. When the force guide sequence ends even if CFEnabled is True, the force control functions will end.

Value	Description
True	The force control functions continue to the next force guide object even when a force guide object is ended.
False	The force control functions end when the force guide object is ended.

Default: False

■ EndCheckOperator Property

This property sets the combination conditions when using several end conditions of the force guide object. When specifying AND, if all of the enabled end conditions are satisfied, the force guide object execution ends. The execution is deemed successful, and it proceeds to the next force guide object. When specifying OR, if some of the enabled end conditions are satisfied, the force guide object execution ends. The execution is determined as succeeded and proceed to the next force guide object.

Value	Description
OR	Combine as OR condition.
AND	Combine as AND condition.

Default: AND

■ ForceCheckEnabled Property

For the force guide object end conditions, this property sets conditions related to force.

Value	Description
True	Enable the end conditions related to force.
False	Disable the end conditions related to force.

Default: False

■ ForceCheckMode Property

This property sets the direction used as an end condition related to force.

Value	Description
Press	Direction (Press+, Press-) specified by ControlMode is a force condition.
PressFollow	Direction (Press+, Press-, and Follow) specified by ControlMode is a force condition.

Default: Press

■ ForceCheckPolarity Property

For an end condition related to force, this property sets whether the end condition is being inside or outside of the specified range.

Value	Description
Outside	Being outside of the specified range is an end condition.
Inside	Being inside of the specified range is an end condition.

Default: Inside

■ PressCheckToF Property

This property sets the range of the end conditions related to force.

It is used when ForceCheckEnabled is True in a direction where Press is specified by ControlMode in Fx, Fy, and Fz directions.

Determine that the force in each direction is inside or outside of the range of PressForce -PressCheckToIF to PressForce +PressCheckToIF.

	Value (unit: [N])
Minimum Value	0.1
Maximum value	10

Default: 1

- PressCheckToIT Property

This property sets the range of the end conditions related to force.

It is used when ForceCheckEnabled is True in a direction where Press is specified by ControlMode in Tx, Ty, and Tz directions.

Determine that the force in each direction is inside or outside of the range of PressForce -PressCheckToIT to PressForce +PressCheckToIT.

	Value (unit: [N · mm])
Minimum Value	If the sequence version is 7.5.1: 1 If the sequence version is 7.4.0: 100
Maximum value	10000

Default: 500

- FollowCheckToIF Property

This property sets the range of the end conditions related to force.

It is used when ForceCheckEnabled is True and ForceCheckMode is set to PressFollow in a direction where Follow is specified by ControlMode in Fx, Fy, and Fz directions.

Determine that the force in each direction is inside or outside of the range of -FollowCheckToIF to +FollowCheckToIF.

	Value (unit: [N])
Minimum Value	0.1
Maximum value	10

Default: 1

- FollowCheckToIT Property

This property sets the range of the end conditions related to force.

It is used when ForceCheckEnabled is True and ForceCheckMode is set to PressFollow in a direction where Follow is specified by ControlMode in Tx, Ty, and Tz directions.

Determine that the force in each direction is inside or outside of the range of -FollowCheckToIT to +FollowCheckToIT.

	Value (unit: [N · mm])
Minimum Value	If the sequence version is 7.5.1: 1 If the sequence version is 7.4.0: 100
Maximum value	10000

Default: 500

- HoldTimeThresh Property

This property sets the duration time until the determination of the end conditions related to force.

It is used when ForceCheckEnabled is True.

When the specified condition continues for the time specified by HoldTimeThresh, it is determined as the end conditions are satisfied.

	Value (unit: [sec])
Minimum Value	0
Maximum value	10

Default: 0

■ PosCheckEnabled Property

This property sets the end conditions of the force guide object related to position.

Value	Description
True	Enable the end conditions related to position.
False	Disable the end conditions related to position.

Default: False

■ PosCheckType Property

For the end conditions related to positions, this property sets whether to use Plane which is defined in advance or set a relative position from the start position of force guide object.

When specifying RobotPlane, set the end conditions by using the defined Plane.

When specifying RelativePlane, reset Plane to the relative position from the force guide object start position each time the force guide object is executed.

Value	Description
RobotPlane	Use the defined Plane as the end condition.
RelativePlane	Set Plane to the relative position and use it as the end condition.

Default: RobotPlane

■ PlaneNumber Property

This property sets the Plane number of the plane that will be used for end conditions related to position.

When specifying Plane in the PosCheckType property, Plane of the specified number will not be changed.

When specifying Relative in the PosCheckType property, redefine a new Plane to the specified number each time the force guide object is executed. Therefore, note that the original setting will be lost.

	Value
Minimum Value	1
Maximum value	15

Default: 1

■ PlaneEndCond Property

For the end conditions related to positions, this property sets the conditions to be determined as an end.

Value	Description
Outside	Being outside of the Plane is an end condition.
Inside	Being inside of the Plane is an end condition.

Default: Inside

■ PlaneRelativeOrg Property

For the end conditions related to positions, this property specifies which coordinate system is used to set the relative

position that sets the Plane.

It is used when RelativePlane is specified by PosCheckType.

Value	Description
Base	Specify a relative position based on the Base coordinate system.
Local	Specify a relative position based on the Local coordinate system. The local coordinate system number is specified by PlaneRelativeRobotLocal.
Tool	Specify a relative position based on the Tool coordinate system.

Default: Tool

■ PlaneRelativeX Property

For the end conditions related to positions, this property sets the relative position in X direction to set Plane.

It is used when RelativePlane is specified by PosCheckType.

X direction follows the coordinate system specified by PlaneRelativeOrg.

	Value (Unit: [mm])
Minimum Value	-2000
Maximum value	2000

Default: 0

■ PlaneRelativeY Property

For the end conditions related to positions, this property sets the relative position in Y direction to set Plane.

It is used when RelativePlane is specified by PosCheckType.

Y direction follows the coordinate system specified by PlaneRelativeOrg.

	Value (Unit: [mm])
Minimum Value	-2000
Maximum value	2000

Default: 0

■ PlaneRelativeZ Property

For the end conditions related to positions, this property sets the relative position in Z direction to set Plane.

It is used when RelativePlane is specified by PosCheckType.

Z direction follows the coordinate system specified by PlaneRelativeOrg.

	Value (Unit: [mm])
Minimum Value	-2000
Maximum value	2000

Default: 0

■ PlaneRelativeOrient Property

For the end conditions related to positions, this property sets the coordinate system to set Plane.

It is used when RelativePlane is specified by PosCheckType.

Plane is set on the axis specified by PlaneAxes, according to the coordinate system specified by PlaneRelativeOrient.

When specifying Base, Plane is set on axis specified by PlaneAxes in the Base coordinate system.

When specifying Local, Plane is set on axis specified in PlaneAxes in the Local coordinate system of the number specified by PlaneRelativeRobotLocal.

When specifying Tool, Plane is set on axis specified by PlaneAxes in the Tool coordinate system.

Value	Description
Base	Specify a Plane direction based on the Base coordinate system.
Local	Specify a Plane direction based on the Local coordinate system.
Tool	Specify a Plane direction based on the Tool coordinate system.

Default: Tool

■ PlaneAxes Property

For the end conditions related to positions, this property sets the axis to set Plane. It is used when RelativePlane is specified by PosCheckType.

Plane is set on the axis specified by PlaneAxes, according to the coordinate system specified by PlaneRelativeOrient.

Value	Description
XY	Set Plane on the XY plane.
YZ	Set Plane on the YZ plane.
XZ	Set Plane on the XZ plane.

Default: XY

■ PlaneRelativeRobotLocal Property

For the end conditions related to positions, this property sets Local coordinate system number that specifies the relative position or direction of Plane.

It is used in either of the following cases: RelativePlane is specified in PosCheckType and Local is specified in PlaneRelativeOrg. RelativePlane is specified in PosCheckType and Local is specified in PlaneRelativeOrient.

Value	Description
0 (Base)	Use the Local 0 coordinate system (Base coordinate system). It is the same as when specifying Base by PlaneRelativeOrg or PlaneRelativeOrient.
1 to 15	Use the Local coordinate system of the specified number.

Default: 0 (Base)

■ IOCheckEnabled Property

This property sets the end conditions of the force guide object related to I/O.

Value	Description
True	Enable the end conditions related to I/O.
False	Disable the end conditions related to I/O.

Default: False

■ IOCheckInputBit Property

This property sets the bit of determination target of the end conditions related to I/O.

It is used when IOCheckEnabled is True.

	Value
Minimum Value	0
Maximum value	7167

Default: 0

■ IOCheckInputStatus Property

This property sets the determination conditions of the end conditions related to I/O.

It is used when IOCheckEnabled is True.

According to the bit specified by IOCheckInputBit, it is determined as the end conditions are satisfied.

Value	Description
Off	When the input bit is OFF (0), it is determined as the end conditions are satisfied.
On	When the input bit is ON (1), it is determined as the end conditions are satisfied.

Default: Off

4.4.2.2.8.4 Details on the results of the PressMove object

■ EndStatus Result

It is a result of the execution.

It succeeds when the "success conditions" described in 4.2.2.2 Relax Object are satisfied.

PressMove Object

Value	Description
Passed	Force guide object is succeeded.
Failed	Force guide object is failed.
NoExec	Force guide object is not executed.
Aborted	Aborted during the execution of force guide object.

■ Time Result

This is the time required for execution.

Unit: [sec]

■ EndForces Result

It is force and torque when force guide object ends. Acquire values of Fx, Fy, Fz, Tx, Ty, and Tz.

Unit: Fx, Fy, Fz [N] / Tx, Ty, Tz [N · mm]

■ EndPos Result

Positions when the force guide object ends. Acquire values of X, Y, Z, U, V, and W.

Unit: X, Y, Z [mm] / U, V, W [deg]

■ AvgForces Result

Average values of force and torque during the force guide object execution. Acquire values of Fx, Fy, Fz, Tx, Ty, and Tz.

Unit: Fx, Fy, Fz [N] / Tx, Ty, Tz [N · mm]

■ PeakForces Result

Peak values of force and torque during the force guide object execution. The peak value is a value which absolute value is the largest. Acquire values of Fx, Fy, Fz, Tx, Ty, and Tz.

Unit: Fx, Fy, Fz [N] / Tx, Ty, Tz [N · mm]

■ ForceCondOK Result

Shows whether the end conditions related to force were satisfied.

Value	Description
True	Satisfy the end conditions related to force.
False	The end conditions related to force are not satisfied.

- **TriggeredForces Result**
It is the force and torque when satisfying the end conditions related to force. Acquire values of Fx, Fy, Fz, Tx, Ty, and Tz.
Unit: Fx, Fy, Fz [N] / Tx, Ty, Tz [N · mm]
- **TriggeredPos Result**
Positions when satisfying the end conditions related to force. Acquire values of X, Y, Z, U, V, and W.
Unit: X, Y, Z [mm] / U, V, W [deg]
- **PosCondOK Result**
Shows whether the end conditions related to position were satisfied.

Value	Description
True	Satisfy the end conditions related to position.
False	The end conditions related to position are not satisfied.

- **IOCondOK Result**
Shows whether the end conditions related to I/O were satisfied.

Value	Description
True	Satisfy the end conditions related to I/O.
False	The end conditions related to I/O are not satisfied.

4.4.2.2.9 Decision Object

Decision object changes the force guide object to be executed based on the results of the objects in the force guide sequence.

This object is used for determination for execution of PressProbe object for Peg In Hole task. This object allows executing the required force guide objects based on the actual motion status of the robot.

4.4.2.2.9.1 Property setting guidelines for the Decision object

Step 1. Set basic information

Set properties (Name, Description, Enabled) related to the basic information.

Properties	Description, setting guide
Name	Name of the force guide object. Set a particular name.
Description	Description for the force guide object. Describe the operations. Set a character string.
Enabled	Set whether to execute the force guide object.
	True : Normal
	False : When you do not execute the force guide object (e.g., when you execute another force guide object instead).

Step 2. Set a condition

Set properties (ConditionObject, TrueCond) related to conditions.

Properties	Description, setting guide
ConditionObject	Force guide object to check the results. Set the force guide object that you want to check.

Properties	Description, setting guide
TrueCond	Set a condition to be True. Proceed to True branching when EndStatus of the force guide object specified by ConditionObject is satisfied a condition specified by TrueCond.

4.4.2.2.9.2 Details on properties of the Decision object

- **Name Property**
 This property sets a particular name that is assigned to force guide object.
 When creating the Decision object, name is assigned automatically. Automatically assigned name is added a number after Decision (e.g. Decision01).
 You can change the name. Set up 16 characters at the maximum. Please use alphanumeric characters and underscores [_].
 Note: The initial character cannot be a numeric character.
- **Description Property**
 This property sets descriptions about force guide objects.
 You can set the character string up to 255 characters.
- **Enabled Property**
 This property sets whether to enable force guide objects.
 When specifying True, the force guide object is executed.
 When specifying False, execute the next force guide object without executing the Decision object or any force guide objects branching from it.
 Use this property when you want to save the force guide sequence temporary or try with different parameters by copying the force guide object during the force guide sequence creation.

Value	Description
True	Enable a force guide object.
False	Disable a force guide object.

Default: True

- **ConditionObject Property**
 Set the force guide object to be a target of the conditional determination.
 Specify the force guide object which is written before the Decision object. Based on that result, the program proceeds to True or False branch.
- **TrueCond Property**
 Set a condition to branch to True.
 Depending on a result of the force guide object (EndStatus result) specified by ConditionObject, the program proceeds to True branch.

Value	Description
TargetPassed	When the target force guide object is succeeded, the program proceeds to True branch.
TargetFailed	When the target force guide object is failed, the program proceeds to True branch.
TargetNoExec	When the target force guide object is not executed, the program proceeds to True branch.

Default: TargetPassed

4.4.2.2.10 SPELFunc Object

SPELFunc object executes the specified SPELFunc during the execution of the sequence.

Use this object for performing processing other than the force control function such as I/O operations or a safety movement to the start position.

A function to be specified by SPELFunc object must have a string type variable for an argument and the return value type must be Boolean. Object name is passed to the argument.

SPELFunc object is succeeded when the return value of the specified function is True, and it failed when the return value is False.

4.4.2.2.10.1 Property setting guideline for SPELFunc object

Step 1. Set basic information

Set properties (Name, Description, Enabled, StepID, AbortSeqOnFail) related to the basic information.

Properties	Description, setting guide
Name	This property sets names of force guide objects. Set a particular name.
Description	This property sets descriptions about force guide objects. Describe the operations. Set a character string.
Enabled	Set whether to execute the force guide object.
	True : Normal
	False : When you do not execute the force guide object (e.g., when you execute another force guide object instead).
StepID	StepID during the force guide object execution. Set an ID. StepID is an ID which is recorded in the log data. It helps you to understand which log data support a process. It is applied when AutoStepID of the force guide sequence is False.
AbortSeqOnFail	It is whether to abort or continue the force guide sequence when the force guide object fails. SPELFunc object is failed when the return value of the SPELFunc to be executed is False.
	True : Normal End a force guide sequence.
	False : Cases where the force guide sequence contains recovery operations in case of failure; cases where the sequence will be able to continue even in the event of a failure.

Step 2. Set a function to be executed

Set a property (FuncName) related to a function to be executed.

Properties	Description, setting guide
FuncName	Set a SPELFunc name to be executed. As the example below, a function to be specified by SPELFunc object must have a string type variable for an argument and the return value type must be Boolean.

```
Function MyFunc(ObjectName$ As String) As Boolean
    MyFunc = True
End
```

4.4.2.2.10.2 Details on the properties of the SPELFunc object

■ Name Property

This property sets a particular name that is assigned to force guide object.

When creating the SPELFunc object, name is assigned automatically. Automatically assigned name is added a number after SPELFunc (e.g. SPELFunc01).

You can change the name. Set up 16 characters at the maximum. Please use alphanumeric characters and underscores [_].

Note: The initial character cannot be a numeric character.

■ Description Property

This property sets descriptions about force guide objects. You can set the character string up to 255 characters.

■ Enabled Property

This property sets whether to enable force guide objects.

When specifying True, the force guide object is executed.

When specifying False, execute the next force guide object without executing the Decision object or any force guide objects branching from it.

Use this property when you want to save the force guide sequence temporary or try with different parameters by copying the force guide object during the force guide sequence creation.

Value	Description
True	Enable a force guide object.
False	Disable a force guide object.

Default: True

■ StepID Property

This property sets StepID during the execution of the force guide objects. It is only used when AutoStepID is False.

	Value
Minimum Value	0
Maximum value	32767

Default: Automatically set according to the numbers of the force guide sequence and the force guide object.

■ AbortSeqOnFail Property

This property sets operations when force guide object fails.

When True is specified: If the force guide object fails, the program ends the force guide sequence and proceeds to the next SPEL statement.

When specifying False: If force guide object fails, the program proceeds to the next force guide object without ending the force guide sequence.

Use this property when you want to continue the force guide sequence (e.g. the recovery processes are included in the force guide sequence when the force guide object fails.)

Value	Description
True	Abort the force guide sequence when the force guide object fails.
False	Start the next force guide sequence when the force guide object fails.

Default: True

■ FuncName Property

Set a name of SPELFunc name to be executed.

A function to be specified by SPELFunc object must have a string type variable for an argument and the return value type must be Boolean.

SPELFunc object is failed when the return value of the SPELFunc to be specified is False.

The following is an example of the available SPELFunc.

```
Function MyFunc(ObjectName$ As String) As Boolean
  MyFunc = True
End
```

4.4.2.2.10.3 Details on results of the SPELFunc object

- EndStatus Result
It is a result of the execution.
It succeeds when the "success conditions" described in 4.2.2.2 Relax Object are satisfied.

SPELFunc Object

Value	Description
Passed	Force guide object is succeeded.
Failed	Force guide object is failed.
NoExec	Force guide object is not executed.
Aborted	Aborted during the execution of force guide object.

- Time Result
This is the time required for execution.
Unit: [sec]

4.4.3 Paste Sequence and Object

The Paste sequence specifies the robot's direction and force, and performs a press action. When it presses, it can also perform the follow motion to align with the surface to be pressed. It is used for pasting the gripped workpiece to the surface of another workpiece.

The Paste sequence is composed of Paste objects. General force guide objects can also be added depending on the work procedure.

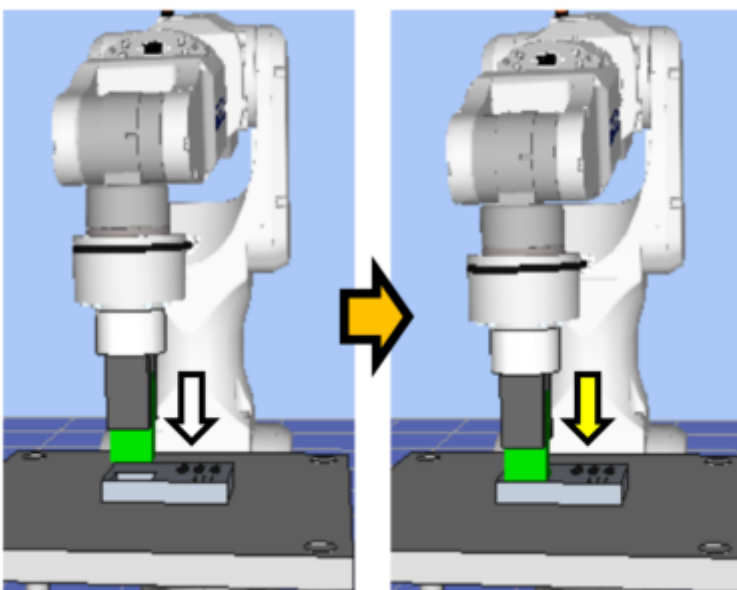

The diagram above provides a visual representation of a Paste sequence. Executed from a non-contact state, this sequence moves the robot in the pressing direction depicted by the white arrow. From the point of contact, the robot continues to apply a

set amount of force in the direction shown by the yellow arrow. The motion procedure up to this point is executed by a Paste object.

This chapter covers the sequence wizards and properties of Paste sequence, Paste objects, and describes how to configure them. For more information about general force guide objects, see the next section.

Software [General force guide object](#)

4.4.3.1 Setting Guidelines for the Paste Sequence Wizard

Use the sequence wizard to create a Paste sequence. This sequence wizard can be displayed by doing the following.

- Right click the sequence flow in the flowchart, or the sequence node in the sequence tree, and then select [Sequence Wizard].
- Click the  button shown to the right of the [Click to open->] Wizard setting in the Paste sequence property.

When the sequence wizard appears, configure settings as instructed on the screen.

The sequence wizard for a Paste sequence can also be configured on the new sequence screen for creating a new force guide sequence. For more information, see the following section.

Software [Force Guidance] [\[Tools\] menu](#)

- Create a new force guide sequence - Sequence Wizard, Create a new system force guide sequence

Step 1. Select the robot tool to use for the end effector

Select the tool number to be used for the Paste sequence and Paste object.

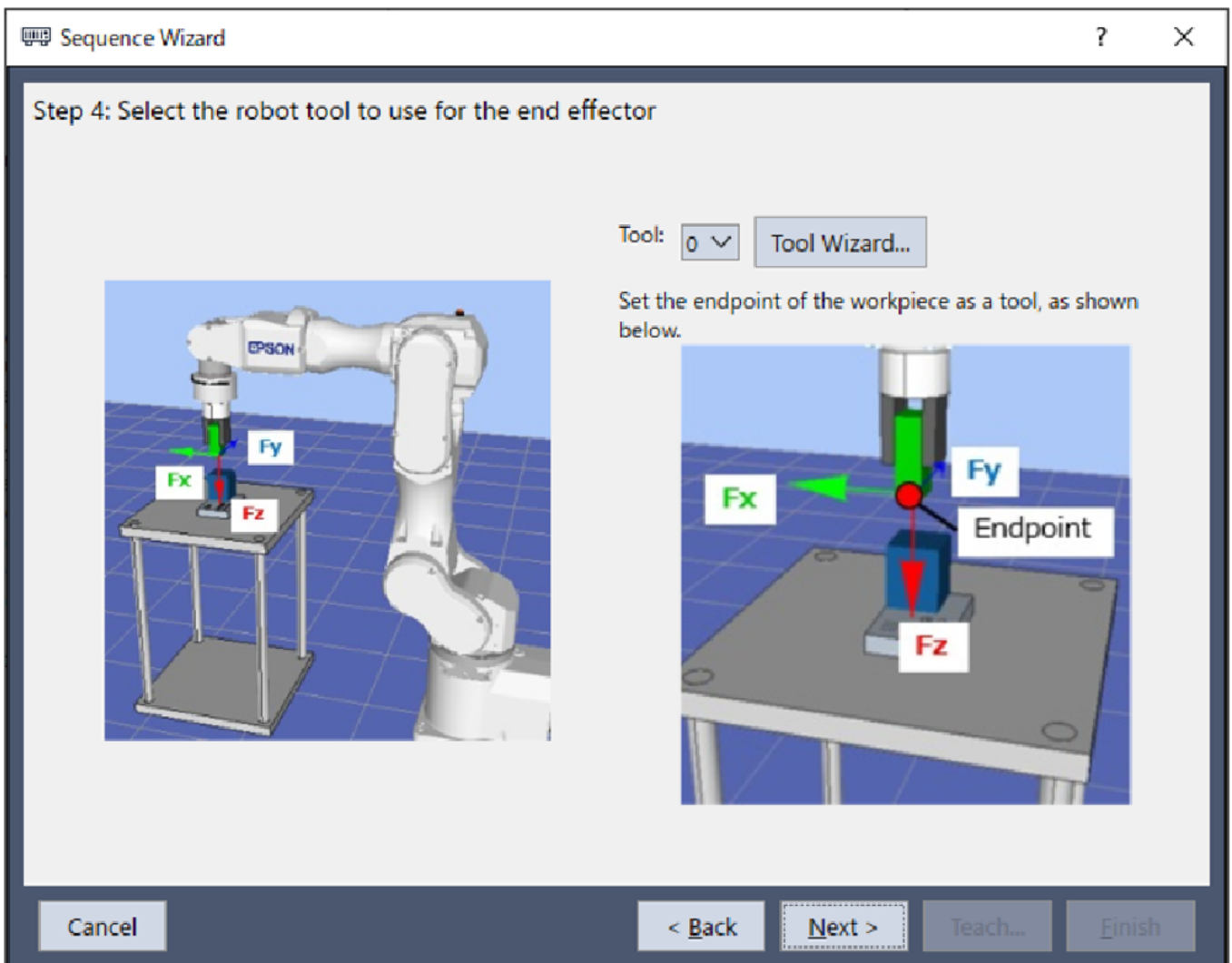

Item	Description, setting guide
Tool	Select the tool number to be used. Select a tool number so that the end point of the workpiece is at the tool origin point. Tool numbers set are sorted in the list. To set a new tool, use the Tool Wizard button. For more information, see the following section. "Epson RC+ 8.0 User's Guide - Epson RC+ 8.0 GUI - [Tools] menu, [Tools] - [Robot Manager] - [Tool Settings] panel" Minimum value: 0 Maximum value: Maximum value for the set tool number Default: 0
[Cancel] button	Cancels a new Paste sequence creation. Click it to end a sequence wizard.
[Back] button	When opening from the new sequence creation screen, you can return to the previous Step.
[Next] button	Proceeds to the next Step.
[Finish] button	You cannot click this button.

Step 2. Set tool offsets

When the tool set in Step 1 is not set in the center of the workpiece tip, this setting is required. Set the offset amount from the tool to the center of the workpiece tip.

Sequence Wizard
? X

Step 5: Set tool offsets

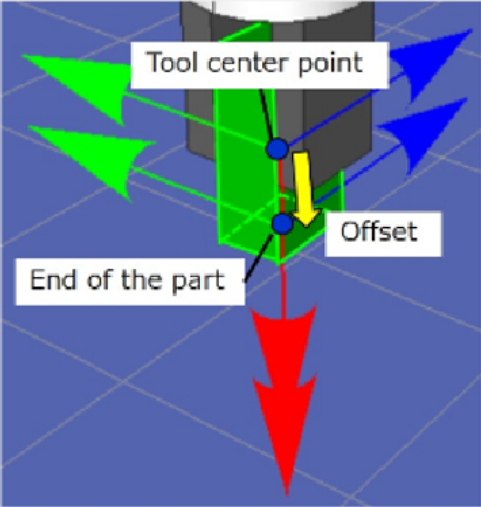

Use the offsets if the tool is not the endpoint of the part.

Set the offsets from X and Y center of the robot tool to the X and Y center of the part. In addition, set the Z offset from the end of the robot tool to the end of the part.

X Offset: mm

Y Offset: mm

Z Offset: mm

Cancel
< Back
Next >
Teach...
Finish

Item	Description, setting guide
X Offset	Sets the offset amount in the X direction from the tool set in Step 1 to the tip of the workpiece. Minimum value: -2000.000 [mm] Maximum value: 2000.000 [mm] Default: 0.000[mm]
Y Offset	Sets the offset amount in the Y direction from the tool set in Step 1 to the tip of the workpiece. Minimum value: -2000.000 [mm] Maximum value: 2000.000 [mm] Default: 0.000[mm]
Z Offset	Sets the offset amount in the Z direction from the tool set in Step 1 to the tip of the workpiece. Minimum value: -2000.000 [mm] Maximum value: 2000.000 [mm] Default: 0.000[mm]
[Cancel] button	Cancels a new Paste sequence creation. Click it to end a sequence wizard.
[Back] button	Returns to the previous Step.
[Next] button	Proceeds to the next Step.
[Finish] button	You cannot click this button.

Step 3. Paste coordinate system and direction

Set the paste direction.

Select "Tool" to perform the paste operation that matches the orientation when starting the sequence.

Select "Base or Local" to perform the paste operation in the direction that matches the workpiece regardless of the orientation

when starting the sequence.

Sequence Wizard

Step 6: Paste coordinate system and direction

- Run the paste in the tool coordinate system
- Run the paste in the selected base or local coordinate system

Robot local: Base

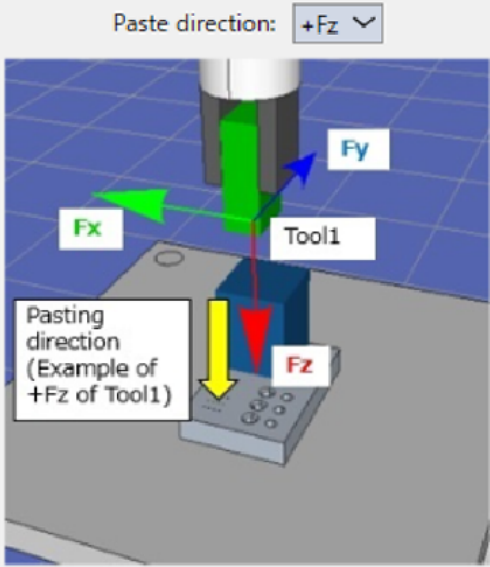
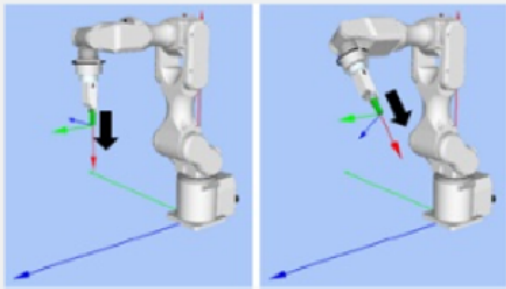

Paste direction: +Fz

Pasting direction (Example of +Fz of Tool1)

Cancel < Back Next > Teach... Finish

Item	Description, setting guide
Robot local	<p>Select the coordinate system used in the Paste sequence.</p> <p>When the paste coordinate system is selected as "Base or Local", the robot operates in this coordinate system.</p> <p>Select the coordinate system according to the workpiece direction to be pasted.</p> <p>Minimum value: Base (0)</p> <p>Maximum value: 15</p> <p>Default: Base</p>
Paste direction	<p>Select the direction to paste.</p> <p>When the paste coordinate system is selected in "Tool", the tool coordinate system set in Step 1 is selected, and the Paste sequence and Paste object operate in the paste direction.</p> <p>When the paste coordinate system "Base or Local" is selected, the Paste sequence and Paste object selected in the base or local coordinate system operate in the paste direction.</p> <p>Values: +Fx, -Fx, +Fy, -Fy, +Fz, -Fz</p> <p>Default: +Fz</p>
[Cancel] button	<p>Cancels a new Paste sequence creation.</p> <p>Click it to end a sequence wizard.</p>
[Back] button	<p>Returns to the previous Step.</p>
[Next] button	<p>Proceeds to the next Step.</p>
[Finish] button	<p>You cannot click this button.</p>

Step 4. Set whether paste surface alignment should be performed

Select whether to enable surface alignment.

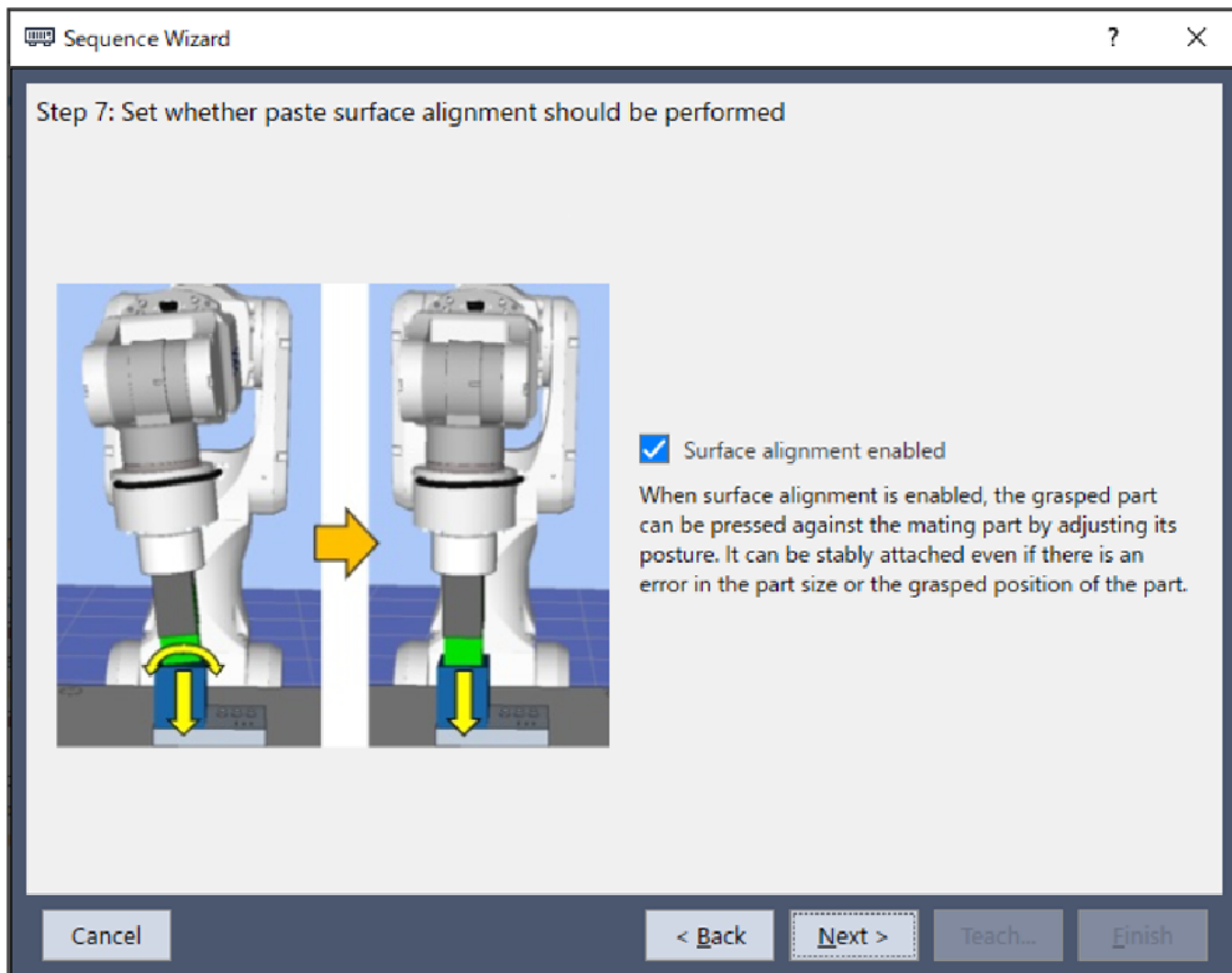

Item	Description, setting guide
Surface alignment enabled	Sets whether to follow the workpiece to the pasting target. When enabled, the operation to follow the surface in the direction of the yellow arrow (rotation) shown on the left of the wizard is performed while the paste operation. Set when pasting is not completed until the workpiece surface and the target surface to be pasted match. Default: Enabled
[Cancel] button	Cancels a new Paste sequence creation. Click it to end a sequence wizard.
[Back] button	Returns to the previous Step.
[Next] button	Proceeds to the next Step.
[Finish] button	You cannot click this button.

Step 5. Set paste approach distance

Set approach distance for paste operation.

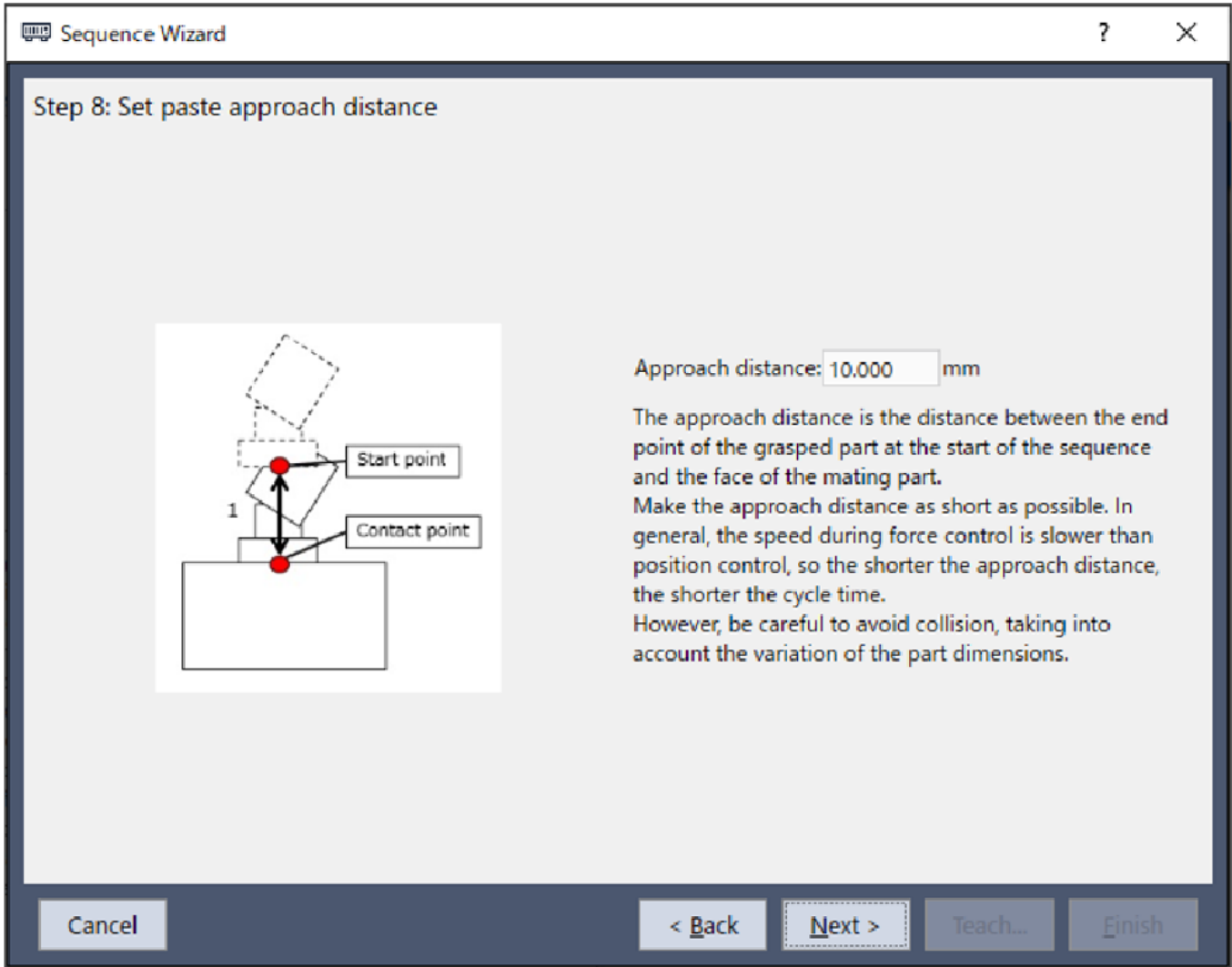

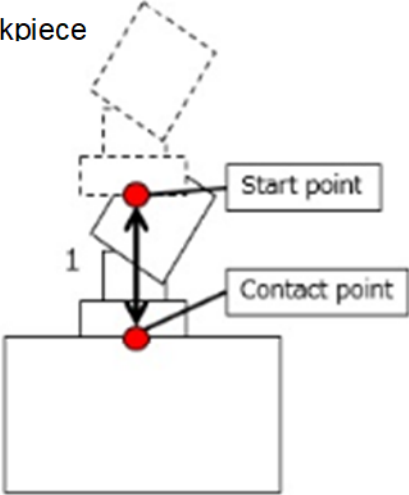

Item	Description, setting guide
Approach distance	<p>Set an approach distance.</p> <p>The approach distance is distance 1 depicted in the diagram below, which is the distance between the end point of the gripped workpiece at the start point of the Paste sequence indicated by the red dot, and upper surface of paste target.</p> <p>Teach the robot a start point of the motion that shortens the approach distance as much as possible. As the force control function is slower than position control, longer approach distances will result in longer cycle times.</p>

Item	Description, setting guide
	<p data-bbox="272 219 424 253">Workpiece</p>  <p data-bbox="571 376 715 409">Start point</p> <p data-bbox="571 477 746 510">Contact point</p> <p data-bbox="400 454 416 488">1</p> <p data-bbox="261 745 531 779">Minimum value: 0 [mm]</p> <p data-bbox="261 781 547 815">Maximum value: 50 [mm]</p> <p data-bbox="261 817 448 851">Default: 10[mm]</p>
[Cancel] button	Cancels a new Paste sequence creation. Click it to end a sequence wizard.
[Back] button	Returns to the previous Step.
[Next] button	Proceeds to the next Step.
[Finish] button	You cannot click this button.

Step 6. Set paste force

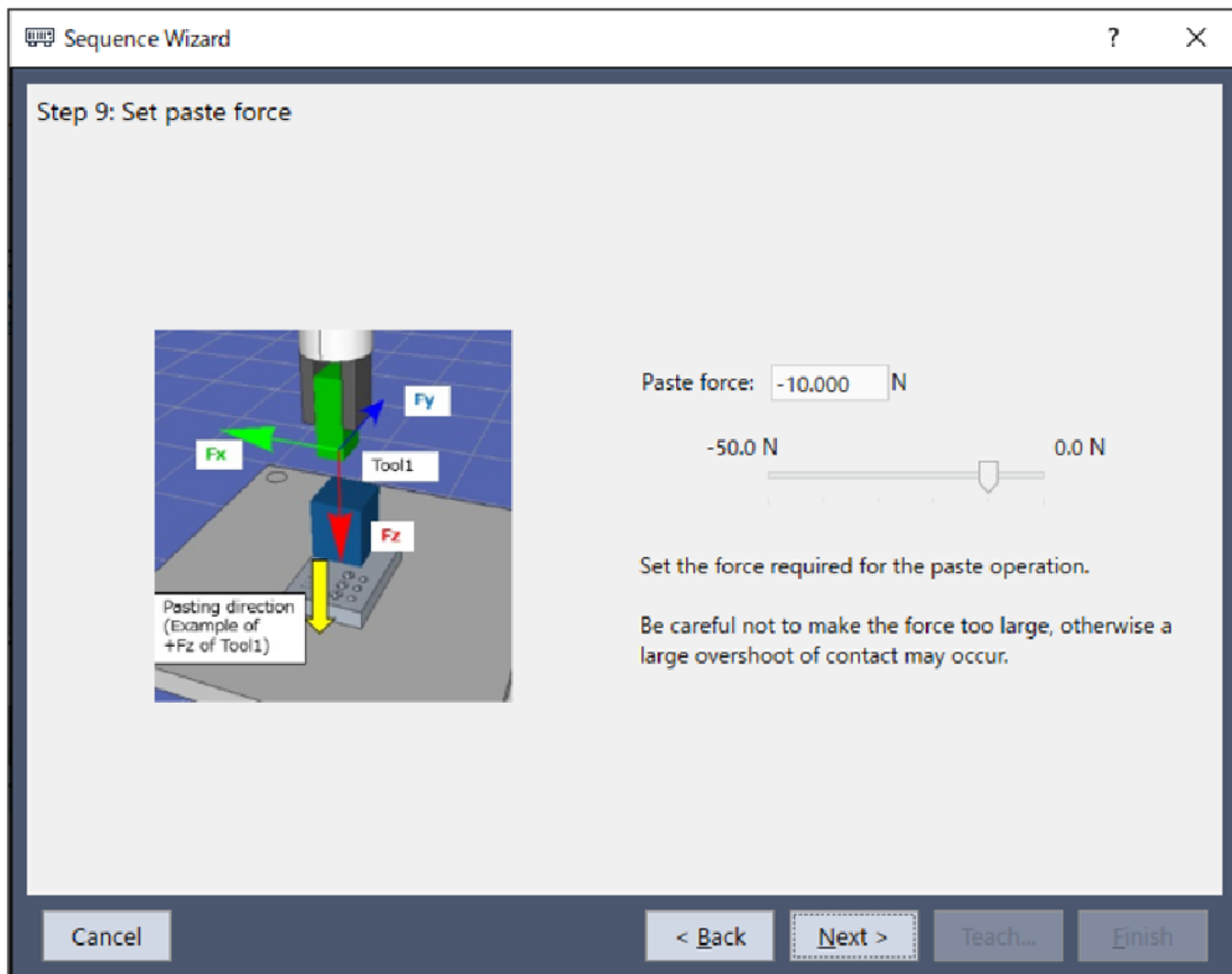
Set force for paste operation.



Item	Description, setting guide
Paste force	Set a force applied to the paste direction. When you press the  button, you can adjust the paste force with the slider.
	When the paste direction is positive Minimum value: -50.0 [N] Maximum value: 0.0 [N] Default: -10.0 [N]
	When the paste direction is negative Minimum value: 0.0 [N] Maximum value: 50.0 [N] Default: 10.0 [N]
[Cancel] button	Cancels a new Paste sequence creation. Click it to end a sequence wizard.
[Back] button	Returns to the previous Step.
[Next] button	Proceeds to the next Step.

Item	Description, setting guide
[Finish] button	You cannot click this button.

Step 7. Set paste firmness

Set the firmness of the force control function in the paste direction from the preset.

While this property setting can be configured directly, this is for advanced users.

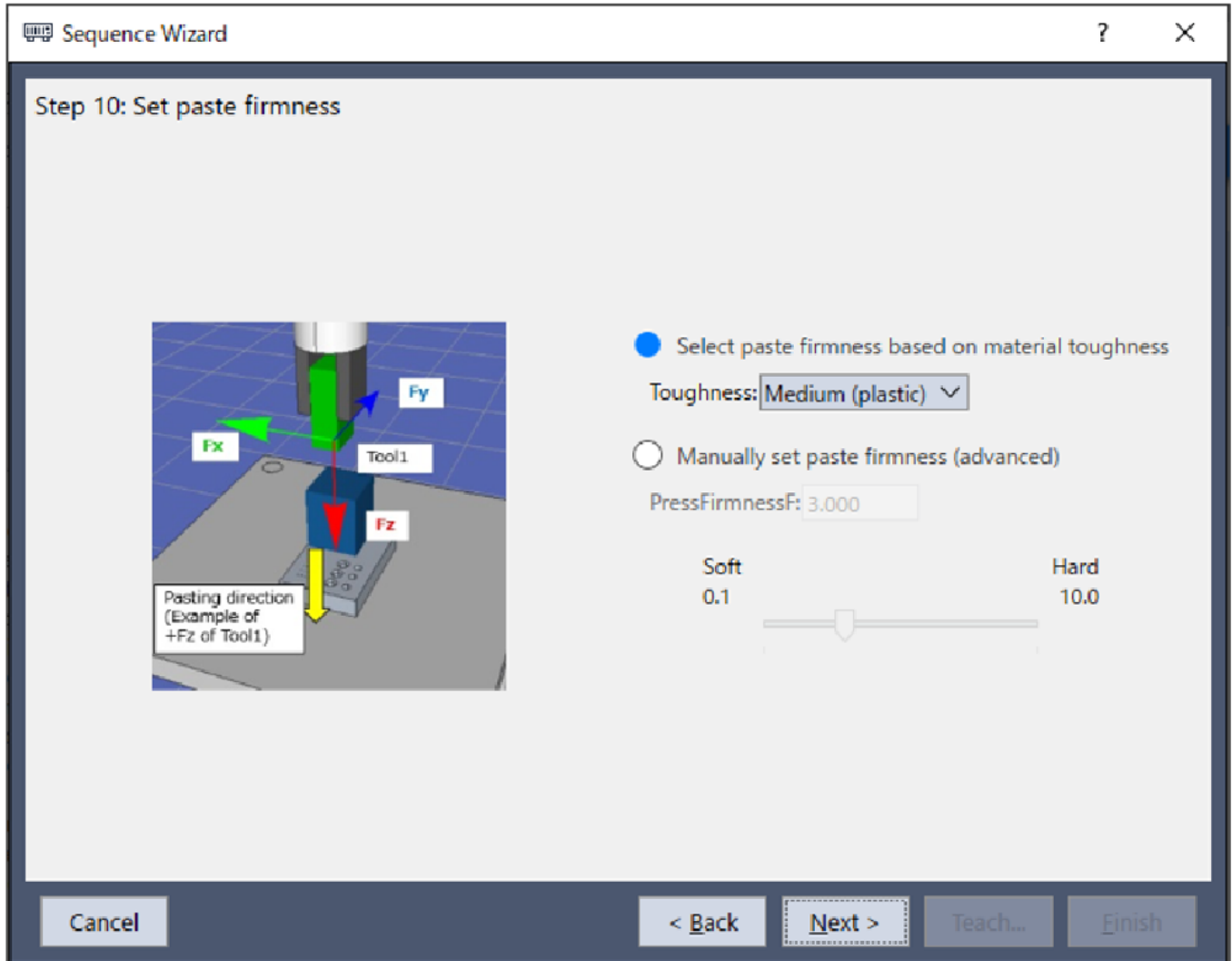

Item	Description, setting guide
Toughness	Set a firmness of the workpiece. Select from three presets, "Fragile (glass)", "Medium (plastic)", or "Hard (metal)"
	When selecting "Fragile": The reaction speed of the force applied in the pasting direction is reduced.
	When selecting "Hard": The reaction speed of the force applied in the pasting direction is increased.
PressFirmnessF	Set the firmness of the force control function in the direction of pasting.
	When setting a large value: The Force Control functions become stronger, but response to changes in force is slow.



Item	Description, setting guide
	<p>When setting a small value: The Force Control function will become weaker. Response to changes in force is fast; however, vibrations can easily occur.</p> <p>This can be set by selecting advanced settings. By pressing the  button, you can adjust the firmness with the slider. Minimum value: 0.1 Maximum value: 10 Default: 3.0</p>
[Cancel] button	Cancels a new Paste sequence creation. Click it to end a sequence wizard.
[Back] button	Returns to the previous Step.
[Next] button	Proceeds to the next Step.
[Finish] button	You cannot click this button.

Step 8. Set paste surface alignment firmness

Set the firmness of the force control function in the paste surface alignment direction from the preset.

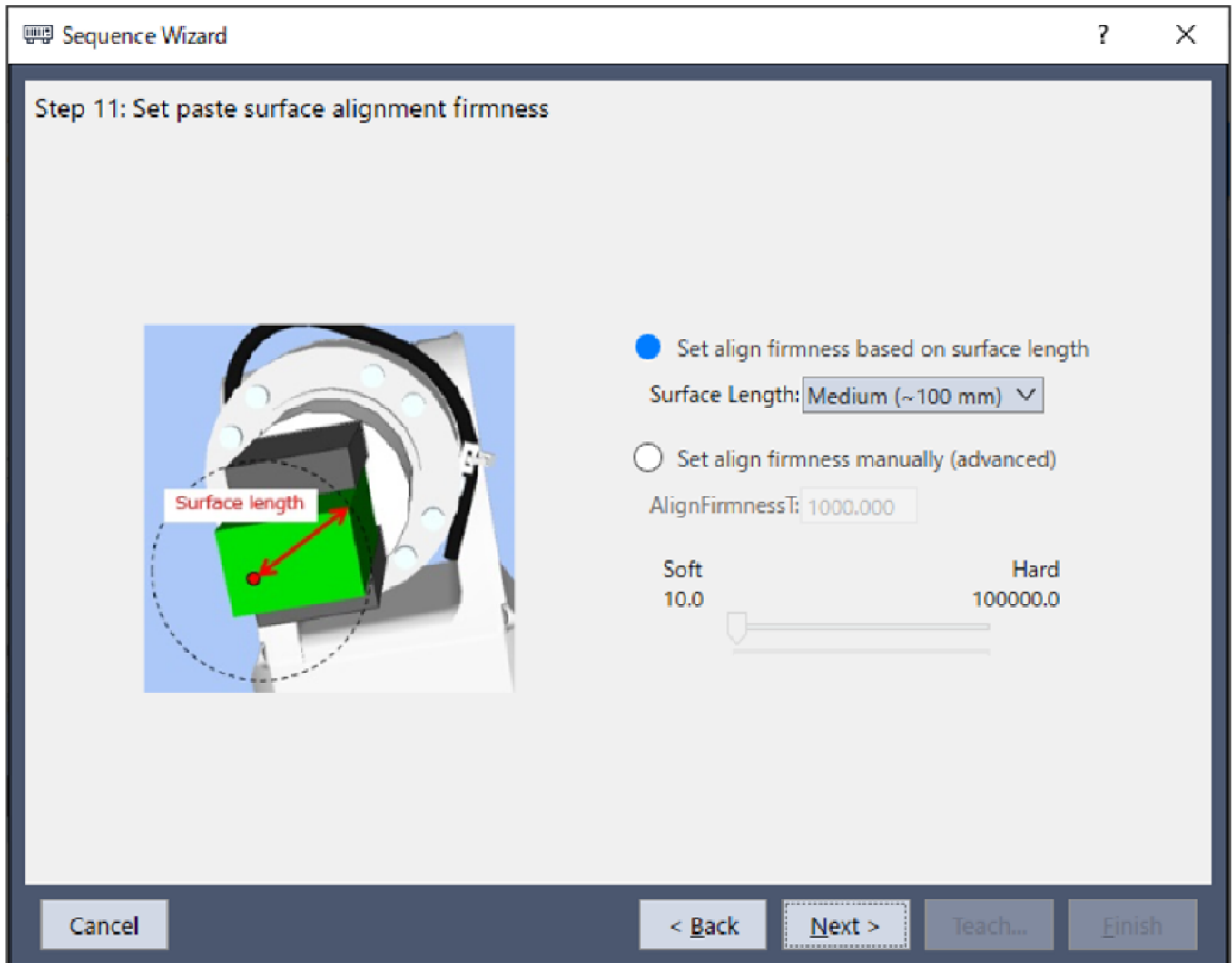
While this property setting can be configured directly, this is for advanced users.

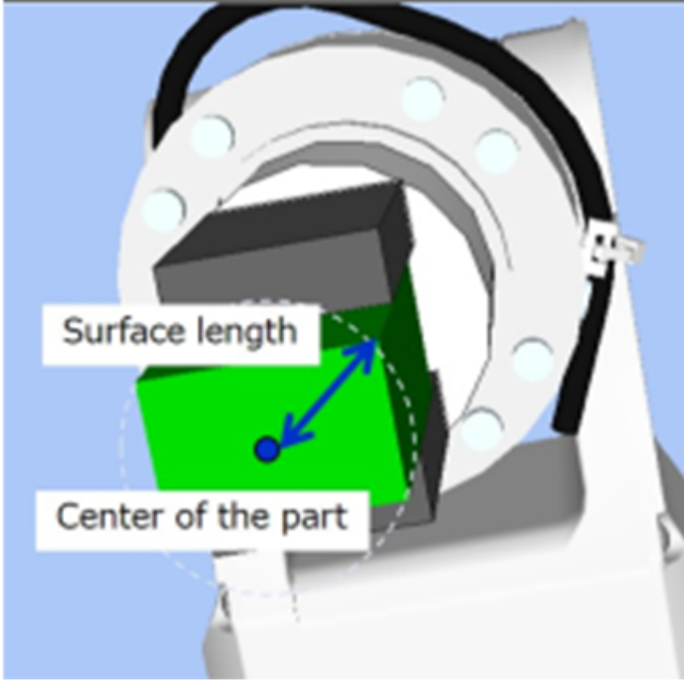

Item	Description, setting guide
Surface Length	<p>Select the length from the contact position (set as tool center position) to the workpiece end point. Choose from three presets: "Short", "Medium", and "Long". The guideline for the tolerance to select is as follows.</p> <p>Short: up to 60 [mm] Medium: up to 100 [mm] Long: up to 200 [mm]</p> <p>The length is the blue arrow in the figure below. This is the length of the radius of a circle from the center point (point of contact) to the most distant edge of the workpiece, thus large enough to fit the surface area of the workpiece.</p>  <p>The shorter the selection, the faster the reaction will follow the face-to-face direction. The longer the selection, the slower the reaction to follow the face-to-face direction.</p>
AlignFirmnessT	<p>Set the firmness of the force control function in the direction of surface alignment.</p> <p>When setting a large value: The Force Control functions become stronger, but response to changes in force is slow.</p> <p>When setting a small value: The Force Control function will become weaker. Response to changes in force is fast; however, vibrations can easily occur.</p> <p>This can be set by selecting advanced settings. Press the  button to adjust the firmness using a slider. Minimum value: 10.0 Maximum value: 100000 Default: 1000</p>
[Cancel] button	<p>Cancels a new Paste sequence creation. Click it to end a sequence wizard.</p>
[Back] button	<p>Returns to the previous Step.</p>
[Next] button	<p>Proceeds to the next Step.</p>

Item	Description, setting guide
[Finish] button	You cannot click this button.

Step 9. Configure the completion conditions for the paste operation

Configure the completion conditions for the paste operation.

Item	Description, setting guide
Force Tolerance	<p>The paste direction range for the end condition related to force. Set a range to use as the end condition. This monitors whether the force in the direction specified either by the Fx, Fy, or Fz paste direction (PasteForce) is within the $\text{PressForce} \pm \text{Tolerance}$ tolerance range. For example, if the direction of insertion is set to +Fz, the force in the Fz direction will be monitored on whether its value is within this range. The following diagram provides a visual representation.</p>

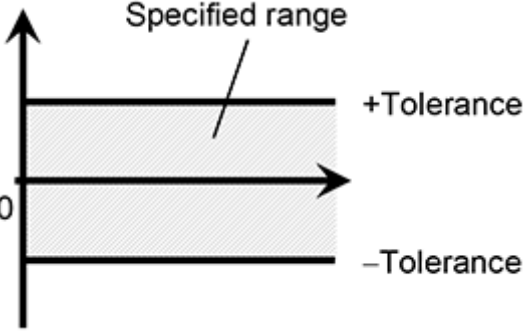
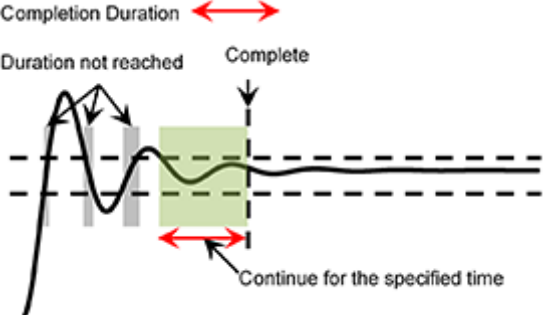
Item	Description, setting guide
	<p>The lower this tolerance value, the stricter success conditions are for the operation. It is recommended that you increase the tolerance, and then adjust it back based on actual operation results obtained.</p> <p>Minimum value: 0.1 [N] Maximum value: 10 [N] Default: 1.0 [N]</p>
Torque Tolerance	<p>Set the range to use as the end condition related to torque.</p> <p>This monitors whether the torque represented by Tx, Ty, or Tz is within the tolerance range. However, note that torque around the direction of paste is not monitored. For example, if the direction of paste is set to +Fz and alignment is enabled, the torque in the Tx and Ty directions will be monitored on whether its value is within this range. If alignment is disabled, torque is not monitored.</p> <p>The following diagram provides a visual representation.</p>  <p>The lower this tolerance value, the stricter success conditions are for the operation. It is recommended that you increase the tolerance, and then adjust it back based on actual operation results obtained.</p> <p>Minimum value: 1 [N·mm] Maximum value: 100000 [N · mm] Default: 100 [N · mm]</p>
Completion Duration	<p>Set the duration time which is used to determine whether the end conditions have satisfied.</p> <p>As shown below, if the specified condition continues for the time specified by Completion Duration, it is determined as the end conditions are satisfied.</p>  <p>Normally, set a short time close to "0".</p> <p>Minimum value: 0.0 [sec] Maximum value: 10 [sec] Default: 0.1 [sec]</p>
[Cancel] button	<p>Cancels a new Paste sequence creation. Click it to end a sequence wizard.</p>
[Back] button	<p>Returns to the previous Step.</p>

Item	Description, setting guide
[Next] button	Proceeds to the next Step.
[Finish] button	You cannot click this button.

Step 10. Set the timeout for the operation

Set the time-out for the operation.

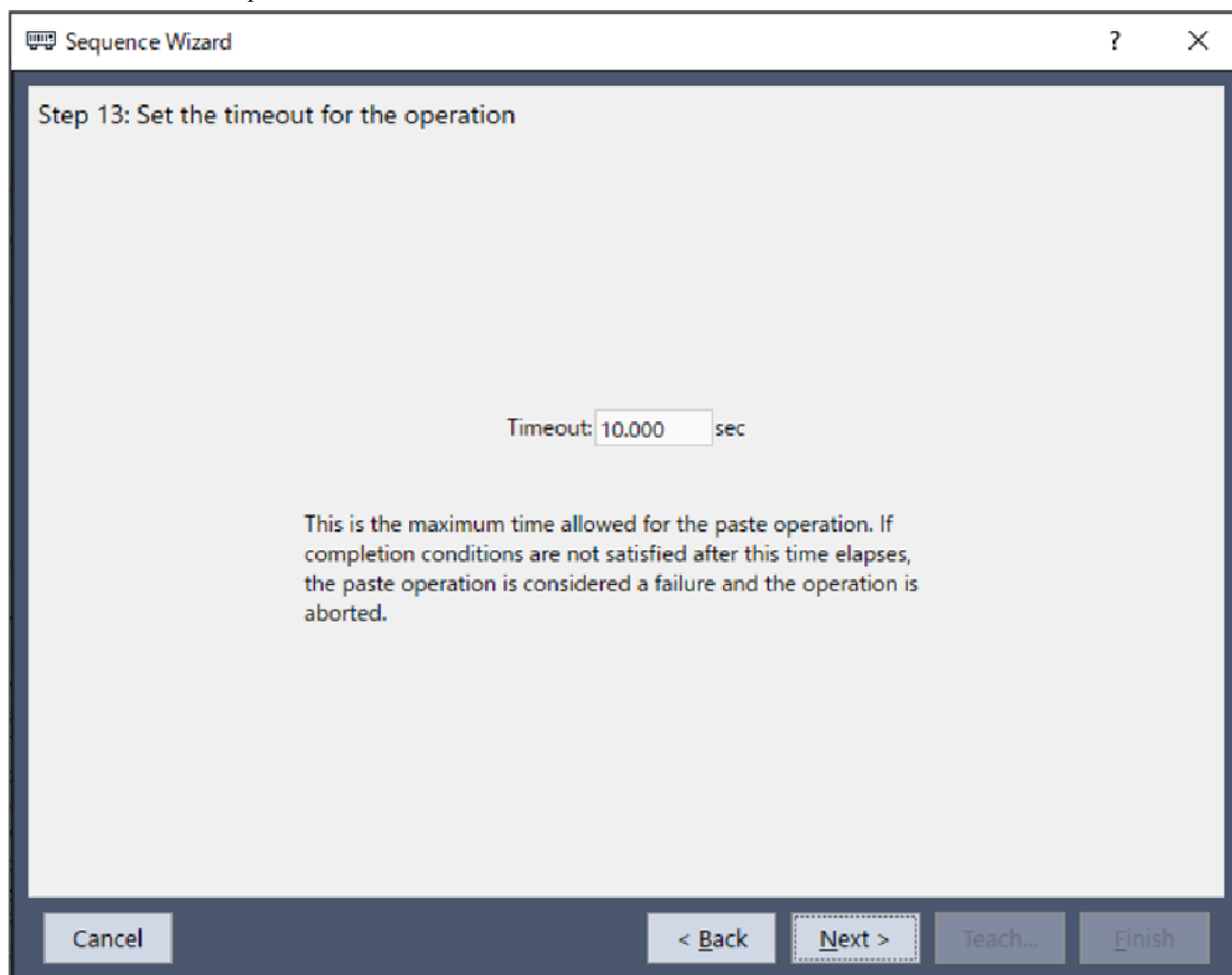

Item	Description, setting guide
Timeout	Set the time-out duration. The time-out set is the paste operation execution time. If the paste operation fails to meet the end conditions set in Step 9 even when the time-out elapses, the paste operation will be aborted in failure. Minimum value: 0.1 [sec] Maximum value: 60 [sec] Default: 10.0 [sec]
[Cancel] button	Cancels a new Paste sequence creation. Click it to end a sequence wizard.
[Back] button	Returns to the previous Step.

Item	Description, setting guide
[Next] button	You can proceed to the Change Summary screen. When you open from the new sequence creation screen, you can proceed to the Finish screen.
[Finish] button	You cannot click this button.

Step 11. Change Summary

You can see the list of properties that have been changed in the wizard.

This is displayed when you edit the created Paste sequence in the Sequence Wizard. It is not displayed when creating a new one.

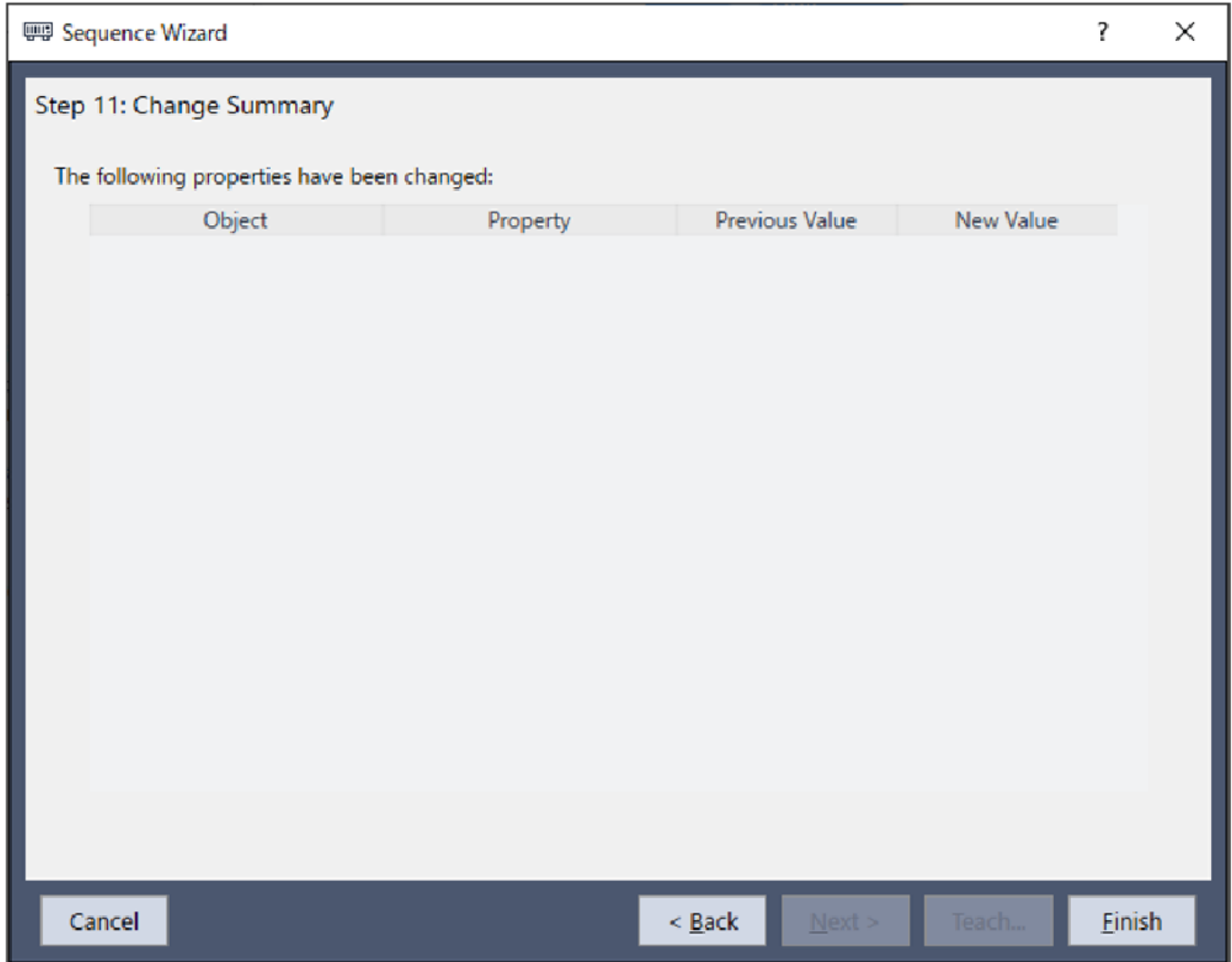

Item	Description
Object Property	Shows which properties of which sequence or object have been changed as a result of changing settings in the wizard.
Previous Value New Value	Shows how the properties have been changed as a result of changing the settings in the wizard.
[Cancel] button	Cancels a new Paste sequence creation. Click it to end a sequence wizard.
[Back] button	Returns to Step 10.

Item	Description
[Next] button	You cannot click this button.
[Finish] button	Completes changing the Paste sequence with the entered contents.

Finish: Paste Sequence Created

This is the completion screen for the set sequence. You can check the created sequence name and type. The screen is displayed when opening from the new sequence creation screen.



Item	Description
Name	The sequence name set in Step 1. General. Refer to the next section for setting the sequence name. Software [Force Guidance] [Tools] menu - Create a new force guide sequence - Sequence Wizard: Create a new system force guide sequence - Step1: General
Type	The sequence type set in Step 3. Select system sequence. Refer to the next section for selecting the sequence type. Software [Force Guidance] [Tools] menu Create a new force guide sequence - Sequence Wizard: Create a new system force guide sequence -Step 3: Select system sequence

Item	Description
[Cancel] button	Cancels a new Paste sequence creation. Click it to end a sequence wizard.
[Back] button	Returns to Step 10.
[Next] button	You cannot click this button.
[Finish] button	Completes creating a new Paste sequence with the entered contents.

4.4.3.2 Paste Sequence

The following describes properties of the Paste sequence and its setting steps.

4.4.3.2.1 Property setting guidelines for Paste sequence

Step 1. Set basic information

Set properties related to the basic information.

Properties	Description
Name	Force guide sequence name. Set a particular name.
Index	Particular number for a force guide sequence. It is assigned automatically. You cannot set this.
Description	Descriptions for force guide sequence. Describe the tasks. Set a character string.
Version	A compatible version of the sequence. The sequence operates with the specified version function.
RobotNumber	Robot number to execute a force guide sequence. Set a robot number to be executed.
RobotType	Robot number to execute a force guide sequence. Set a robot number to be executed.
AutoStepID	Set whether to set StepID of force guide object automatically. StepID is an ID which is recorded in the log data. It helps you to understand which log data support a process. True: Normal False: When you want to set StepID manually.
PointFile	Set a point file which will be used in a force guide sequence. An error occurs when the specified point file is not loaded at the start. This is a property for preventing a wrong operation. If a point file is not set, any point file whichever loads is executed.
RobotTool	Set a tool number which will be used in a force guide sequence. An error occurs when the set tool number is not selected at the start. This is a property for preventing a wrong operation.

Step 2. Set for correction of sensor value

Set properties (ResetSensor, MPNumber) related to sensor value correction.

Properties	Description, setting guide
ResetSensor	Set whether to reset the Force Sensor when executing a force guide object other than Decision object and SPELFunc object for the first time during the force guide sequence execution.
	<p>True: When a workpiece has not been in contact with anything at the start of the force guide sequence. (Normally, it is in the non-contact state at the start of the force guide sequence.)</p> <p>False : Used in rare cases, such as when a force guide sequence is executed, and then another force guide sequence is executed with the contact state unchanged.</p>
MPNumber	Specify the number of Mass Property Object which is used during the force guide sequence execution. Mass Property Object is a collection of properties using for gravity compensation.
	<p>"0": When the orientations (U, V, W) do not change greatly during the force guide sequence execution.</p> <p>Created Mass Property number: When the orientations change greatly during the force guide sequence execution.</p>
	For more details on Mass Property, refer to the following section. Software Gravity Compensation

Step 3. Set for coordinate system of force control function

Set properties (ForceOrient, RobotLocal, RotationCenterType, RotationCenterTLX, RotationCenterTLY, RotationCenterTLZ) related to a coordinate system of the force control function.

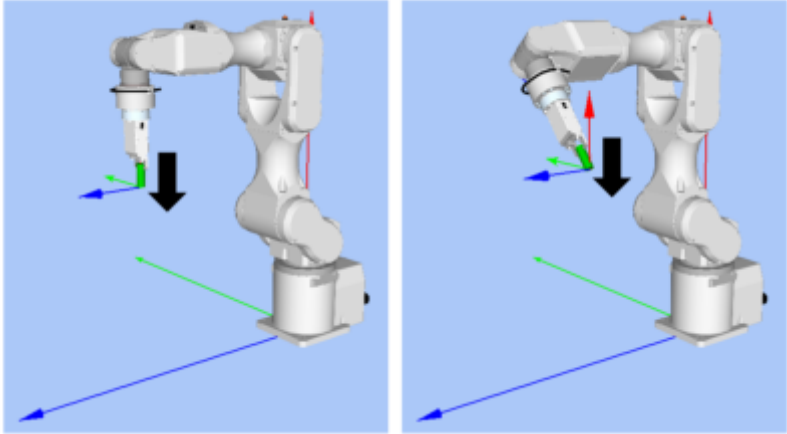
Properties	Description, setting guide
ForceOrient	Set a coordinate system direction which executes the force control function.
	<p>Base, Local: When you want to execute the force control function to a defined direction as viewed from outside, such as pressing to vertical-downward, even if the start orientation of force guide sequence is changed.</p> <p>Local is specified when a defined direction is different from the axis of the Base coordinate system. The following is an example to set Base.</p> 

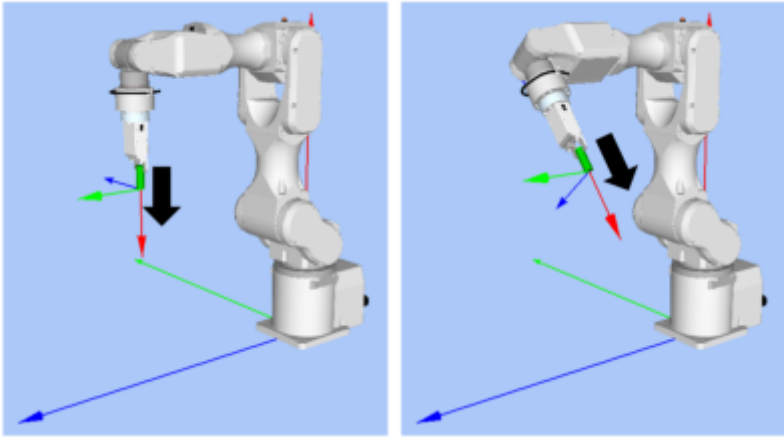
Properties	Description, setting guide
	<p>Tool: When you want to execute the force control function depending on an orientation at the start. The following is an example to set Tool. When pressing to +Z direction, the pressing direction changes depending on the orientation of end effector at the start.</p> 
RobotLocal	Set Local coordinate system number which is used when ForceOrient is Local.
RotationCenterTLX RotationCenterTLY RotationCenterTLZ	Set an offset amount to each axis from Tool coordinate system to the rotation center.

You can check the settings related to the coordinate system of the force control function by using a simulator. However, if no force guide object is aligned in the force guide sequence, check the setting after adding the force guide objects. For details on how to check by using simulator, refer to the following manual.
 "Epson RC+ 8.0 User's Guide: - Simulator - Description of Functions"

Step 4. Set the maximum speed and the maximum acceleration

Set properties (LimitAccelS, LimitAccelR, LimitSpeedS, LimitSpeedR) related to the maximum speed and the maximum acceleration.

Properties	Description, setting guide
LimitSpeedS LimitSpeedR	Set a maximum speed during the execution of the force guide sequence. LimitSpeedS: Maximum translational speed LimitSpeedR: Maximum rotational rotation speed In the force control function, the speed changes depending on the how the force is applied. It is controlled not to exceed LimitSpeedS and LimitSpeedR.
LimitAccelS LimitAccelR	Set a maximum acceleration during the execution of the force guide sequence. LimitAccelS: Maximum translational acceleration LimitAccelR: Maximum rotational rotation acceleration In the force control function, the acceleration changes depending on how the force is applied. It is controlled not to exceed LimitAccelS and LimitAccelR. If the value is small, reaction when the force is applied will be slow and the robot will bounce largely. Set a larger value when the robot bounces. When the robot vibrates, set the value smaller.

Step 5. Set conditions about recording

Set properties (LogRobotLocal, LogFileEnabled, LogFileAutoName, LogFileNameVar, LogFileMaxTime, LogFileInterval) related to recording.

Properties	Description, setting guide
LogRobotLocal	Set a Local coordinate system number which will be a reference of the recording robot position. Log data related to positions is recorded as positions of the specified Local coordinate system.
	Base: Normal
	Local coordinate system number: When you want to record as a position in the specified Local coordinate system
LogFileEnabled	Set whether to save the log data which is executing a force guide sequence to a file.
	False: It is not saved in a file. You can check the log data on the graph of force guide window when executing.
LogFileAutoName	Set whether to set the log data file name automatically.
	True : When Automatically set Is generated by the force guide sequence name and the start time. "Force guide sequence name_yyyymmdd_hh:mm:ss.ms"
	False: When specifying a name
LogFileNameVar	Set a global variable which indicates a log data file name when LogFileAutoName is False.
LogFileInterval	Set a sampling interval of log data when creating files.
LogFileMaxTime	Set a maximum time of log data when creating files.

4.4.3.2.2 Details on properties of Paste sequence

- Name Property

This property sets a particular name that is assigned to force guide sequences.

You cannot create the force guide sequence with the same name.

You can change the name. Set up 16 characters at the maximum. Please use alphanumeric characters and underscores [_].

Note: The initial character cannot be a numeric character.

- Index Property

This property displays a number of force guide sequence.

This property is set and updated automatically. It cannot be edited.

	Value
Minimum Value	1
Maximum value	32

- Description Property

This property sets a description of force guide sequence.

You can set the character string up to 255 characters.

- Version Property

For system sequence, the version 7.5.1 supports. It cannot be changed.

- RobotNumber Property

This property sets a robot number that uses a force guide sequence.

An error occurs when executing the force guide sequence by the robot which is not specified.

Value	Description
1 to 16	Robot number to use a force guide sequence.

Default: Robot number specified in the sequence wizard.

▪ RobotType Property

This property is the robot types that use a force guide sequence.
It is automatically set from the robot number specified by RobotNumber. It cannot be edited.

▪ AutoStepID Property

This property sets an automatic assignment of StepID in force guide object execution.
When assigning a StepID automatically, it is set to the force guide sequence number*100 + the force guide object number.
StepID is recorded to files that the force and the position during the force guide sequence execution is recorded. It is used to determine which interval corresponds to which force guide object.

Value	Description
True	Set StepID automatically.
False	Set a property value of StepID of each force guide object.

Default: True

▪ ResetSensor Property

This property sets whether to reset a Force Sensor when starting force guide object other than Decision object and SPELFunc object for the first time in the force guide sequence.

Value	Description
True	Reset the Force Sensor when starting a force guide object other than Decision object and SPELFunc object.
False	Force Sensor is not reset.

Default: True

▪ MPNumber Property

This property sets the number of Mass Property Object which is used during the force guide sequence execution.
Mass Property Object is a collection of properties using for gravity compensation.
You need to define Mass Property Object in advance.
If an angle will change largely during the execution of the force guide sequence, make sure to specify the proper Mass Property Object.

Value	Description
0	Turn OFF the gravity compensation.
1 to 15	Use the specified Mass Property.

Default: 0

▪ PointFile Property

This property sets the point file name that is used during the force guide sequence execution.
If the point file which is not specified by this property is loaded when the force guide sequence starts, an error occurs. This is a property for preventing a wrong operation.

Value	Description
None	Not specified (Any point file whichever loads can be executed without checking it.)
Point file name	An error occurs when the specified point file is not loaded.

Default: None

▪ RobotTool Property

This property sets the Tool coordinate system number that is used during the force guide sequence execution.

If the Tool coordinate system number which is not specified by this property is selected when the force guide sequence starts, an error occurs. This is a property for preventing a wrong operation.

Value	Description
0 to 15	An error occurs when the set tool number is not selected.

Default: 0

- ForceOrient Property

This property specifies the direction of coordinate system that uses the force control functions during the force guide sequence execution.

You can select from Base, Local, and Tool. Specify the coordinate system that the direction to paste.

If Base or Local is specified, the direction to paste will not be changed even if the robot orientation changes.

If Tool is specified, the direction to paste changes since the direction of Tool coordinate system changes when the robot orientation is changed.

Value	Description
Base	The direction of the coordinate system to which the force control function is applied is the Base coordinate system
Local	The direction of the coordinate system to which the force control function is applied is the Local coordinate system
Tool	The direction of the coordinate system to which the force control function is applied is the Tool coordinate system

Default: Tool

- RobotLocal Property

This property specifies the Local coordinate system number of coordinate system that applies the force control functions during the force guide sequence execution.

It is used when ForceOrient property is Local.

Value	Description
0 (Base)	Use the Local 0 coordinate system (Base coordinate system). It is the same as when specifying Base in ForceOrient.
1 to 15	Use the Local coordinate system of the specified number.

Default: 0 (Base)

- RotationCenterTLX Property

This property sets a distance in X direction from Tool coordinate system to the rotation center of the force control function.

It is the X direction of the Tool coordinate system which is selected in RobotTool.

	Value (Unit: [mm])
Minimum Value	-2000
Maximum value	2000

Default: 0

- RotationCenterTLY Property

This property sets a distance in Y direction from Tool coordinate system to the rotation center of the force control function.

It is the Y direction of the Tool coordinate system which is selected in RobotTool.

	Value (Unit: [mm])
Minimum Value	-2000

Maximum value	2000
---------------	------

Default: 0

■ RotationCenterTLZ Property

This property sets a distance in Z direction from Tool coordinate system to the rotation center of the force control function. It is the Z direction of the Tool coordinate system which is selected in RobotTool.

	Value (Unit: [mm])
Minimum Value	-2000
Maximum value	2000

Default: 0

■ LimitSpeedS Property

This property sets the maximum speed during the execution of force guide sequence.

The robot motion will change depending on applied force and torque when executing the force guide sequence since it is adjusted by the force control functions. However, it is restricted by the speed which is specified by this property.

	Value (unit: [mm/sec])
Minimum Value	0.1
Maximum value	250

Default: 50

■ LimitSpeedR Property

This property sets the maximum rotation speed during the execution of force guide sequence.

The robot motion will change depending on applied force and torque when executing the force guide sequence since it is adjusted by the force control functions. However, it is restricted by the rotation speed which is specified by this property.

	Value (unit: [deg/sec])
Minimum Value	0.1
Maximum value	180

Default: 25

■ LimitAccelS Property

This property sets the maximum acceleration during the execution of force guide sequence.

The robot motion will change depending on applied force and torque when executing the force guide sequence since it is adjusted by the force control functions. However, it is restricted by the acceleration which is specified by this property.

	Value (unit: [mm/sec ²])
Minimum Value	0.1
Maximum value	25000

Default: 200

■ LimitAccelR Property

This property sets the maximum rotation acceleration during the execution of force guide sequence.

The robot motion will change depending on applied force and torque when executing the force guide sequence since it is adjusted by the force control functions. However, it is restricted by the rotation acceleration which is specified by this property.

	Value (unit: [deg/sec ²])
Minimum Value	0.1

	Value (unit: [deg/sec ²])
Maximum value	5000

Default: 100

■ LogRobotLocal Property

For the positional orientation of the robot that is recorded during the force guide sequence execution, set a reference local coordinate system number.

The position of the robot is recorded as that of Tool coordinate system as viewed from the Local coordinate system specified by this property.

Value	Description
0 (Base)	Use the Local 0 coordinate system (Base coordinate system).
1 to 15	Use the Local coordinate system of the specified number.

Default: 0 (Base)

■ LogFileEnabled Property

This property sets whether to save the force, torque, and the position of the robot during the force guide sequence execution in files.

When specifying True, value will be displayed in the graph on the monitor and saved in the files simultaneously.

When specifying False, value will be displayed in the graph on the monitor. However, the value is not saved in the files.

Value	Description
True	Save the log data in a file.
False	The log data is not saved in a file.

Default: False

■ LogFileAutoName Property

This property sets whether to automatically set the file name that records force, torque, and the position of the robot during the force guide sequence execution.

When specifying True, the file name is automatically set with the force guide sequence name + start time.

Force guide sequence name `__yyymmdd_hhmmssfff.csv`

When specifying False, add ".csv" to the string in variables which is specified in LogFileNameVar to make it a file name.

Value	Description
True	Set the name of the log data file automatically.
False	Set a log data file name to the one which is specified by LogFileNameVar.

Default: True

■ LogFileNameVar Property

This property sets a global string variable that saves a file name which records force, torque, and the position of the robot during the force guide sequence execution.

It is used when False is specified in LogFileAutoName. Add ".csv" to the string in variables and set it as a file name.

Value	Description
None	Not specified (automatically set)

Value	Description
Variable name	Value of the specified global string variable will be a file name. Only a string variable can be specified.

Default: None

▪ LogFileInterval Property

This property sets the sampling period for the files that record force, torque, and the position of the robot during the force guide sequence execution.

	Value (unit: [sec])
Minimum Value	0.002
Maximum value	1

Default: 0.2

▪ LogFileMaxTime Property

This property sets the maximum recording time for the files that record force, torque, and the position of the robot during the force guide sequence execution.

If the specified recording time is shorter than the execution time of the force guide sequence, nothing is recorded in the file after the recording time is passed. note that

	Value (unit: [sec])
Minimum Value	60
Maximum value	600

Default: 60

4.4.3.2.3 Details on the results of the Paste sequence

▪ EndStatus Result

It is a result of the execution.

Result will be succeeded when the force guide sequences are executed to the end and the final force guide object is succeeded or AbortSeqOnFail property of the final force guide object is False.

Value	Description
Passed	Force guide sequence is succeeded.
Failed	Force guide sequence is failed.
NoExec	Force guide sequence is not executed.
Aborted	Aborted during the execution of force guide sequence.

▪ FailedStatus Result

It is the reason why the force guide sequence failed.

It is the reason for failure when the result of executing an object with AbortSeqOnFail set to True.

Value	Description
OK	Force guide sequence is succeeded.
GeneralObjectFailed	General object is failed.
ForceConditionFailed	Failed due to the force is out of the range of success conditions.

Value	Description
PosConditionFailed	Failed due to the position is out of the range of success conditions.
Overrun	Failed due to overrun.

- **Time Result**
This is the time required for execution.
Unit: [sec]
- **LastExecObject Result**
Force guide object name which is executed at the end.
- **EndForces Result**
Force and torque when force guide sequence ends. Acquire values of Fx, Fy, Fz, Tx, Ty, and Tz.
Unit: Fx, Fy, Fz [N] / Tx, Ty, Tz [N · mm]
- **PeakForces Result**
Peak values of force and torque during the force guide object execution. The peak value is a value which absolute value is the largest. Acquire values of Fx, Fy, Fz, Tx, Ty, and Tz.
Unit: Fx, Fy, Fz [N] / Tx, Ty, Tz [N · mm]

4.4.3.3 Paste Object

The Paste object is a force guide object used to move the robot by pressing in a specified direction with a specified amount of force. When pressing, operation to follow is also available to follow the pressed surface.

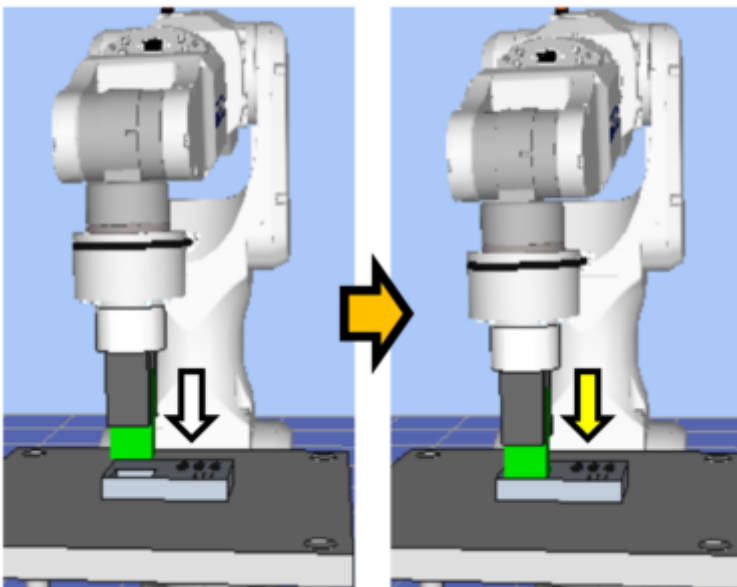

The diagram above provides a visual representation of a Paste object. Executed from a non-contact state, this sequence moves the robot in the pressing direction depicted by the white arrow. From the point of contact, the robot continues to apply a set amount of force in the direction shown by the yellow arrow.

- The Paste object succeeds or fails when the end conditions are met within the specified time. The Paste object can apply end conditions related to force and position.
- Each end condition is always applied.
- When all the success conditions for each end condition are met:
The Paste object execution ends. The execution is determined to be successful and the force guide sequence proceeds to the next force guide object.

- When at least one of the failure conditions for each end condition is met:
The Paste object execution ends. The execution is determined as failed and the force guide sequence is aborted.

End condition	Success condition
End conditions related to force	During the specified Timeout period, keep all of the following conditions satisfied for the length of the HoldTimeThresh period: In Fx, Fy, or Fz, the axis which is specified in PressOrient should be within the range of PressForce - PressCheckToIF to PressForce + PressCheckToIF In Tx, Ty, Tz, The axis torque which is specified in FollowOrient Should be within the range of -FollowCheckToIT to +FollowCheckToIT
End conditions related to position	Satisfy the following within the specified time of Timeout. The moving distance from the force guide object start point in the axial direction specified in PressOrient is within the range of ApproachDist - DistCheckTol to ApproachDist + DistCheckTol

End condition	Failure condition
related to position End condition	Satisfy the following within the specified time of Timeout. The moving distance from the force guide object start point in the axial direction specified in PressOrient is exceeds the range of ApproachDist + DistCheckTol

4.4.3.3.1 Property guideline for Paste object

Step 1. Set basic information

Set properties (Name, Description, StepID, AbortSeqOnFail) related to the basic information.

Properties	Description, setting guide
Name	This property sets names of force guide objects. Set a particular name.
Description	This property sets descriptions about force guide objects. Describe the operations. Set a character string.
StepID	StepID during the force guide object execution. Set an ID. StepID is an ID which is recorded in the log data. It helps you to understand which log data support a process. It is applied when AutoStepID of the force guide sequence is False.
AbortSeqOnFail	Set whether to abort or continue the force guide sequence when the force guide object fails.
	True : Normal End a force guide sequence.
	False : Cases where the force guide sequence contains recovery operations in case of failure; cases where the sequence will be able to continue even in the event of a failure.

Step 2. Set a destination point

Set properties (ApproachDist) related to trajectories to move.

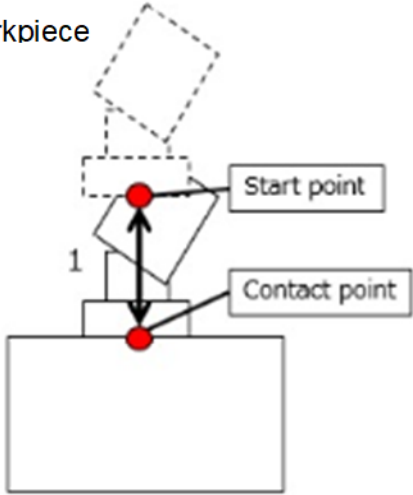
Properties	Description, setting guide
ApproachDist	<p>Set an approach distance. The approach distance is distance 1 depicted in the diagram below, which is the distance between the end point of the gripped workpiece at the start point of the Paste sequence indicated by the red dot, and upper surface of paste target.</p>  <p>Teach the robot a start point of the motion that shortens the approach distance as much as possible. As the force control function is slower than position control, longer approach distances will result in longer cycle times.</p>

Step 3. Set the pressing direction and force control functions

Set properties (PressOrient, PressForce, PressFirmnessF, AlignEnabled, AlignOrient, AlignFirmnessT) related to the pressing direction and force control functions.

Properties	Description, setting guide
PressOrient	Set a direction to press. The robot moves to the specified direction.
PressForce	Set a force to press in the paste direction. When PressOrient is positive direction: Enter a negative value. When PressOrient is negative direction: Enter a positive value. Set a proper value for your workpiece. If the value is too small, the robot may not operate.
PressFirmnessF	Set a firmness of the force control functions. When setting a large value: The Force Control functions become stronger, but response to changes in force is slow. When setting a small value: The Force Control function will become weaker. Response to changes in force is fast; however, vibrations can easily occur.
AlignEnabled	This property sets whether to execute surface alignment.

Properties	Description, setting guide
AlignOrient	Rotational direction for aligning surfaces. It is changed automatically according to PressOrient. Read only. It cannot be edited. Rotate around two translational directions which are not set by PressOrient. For example, when specifying +Fz or -Fz in PressOrient, Tx and Ty (rotation around Fx and Fy) will be AlignOrient.
AlignFirmnessT	Set a firmness of the force control functions in rotation direction.
	When setting a large value: The Force Control functions become stronger, but response to changes in force is slow.
	When setting a small value: The Force Control function will become weaker. Response to changes in force is fast; however, vibrations can easily occur.

You can check the settings of PressOrient by a simulator.

A coordinate system with grayed out except the specified direction is displayed.

However, the robot is displayed based on the current position. When you check the settings, make sure to move the robot to the position where executing the force guide object.

For details on how to check by using simulator, refer to the following manual.

"Epson RC+ 8.0 User's Guide: - Simulator - Description of Functions"

Step 4. Set basic information for end conditions

Set property (Timeout) related to time-out.

Properties	Description, setting guide
Timeout	Set the time-out duration. When the end conditions are not set: Time-out period is the execution time. When the end conditions are set: Fails when the end conditions are not satisfied within the specified time.

Step 5. Set end conditions related to force

Set properties (PressCheckToIF, AlignCheckToIT, HoldTimeThresh) related to the end conditions of force.

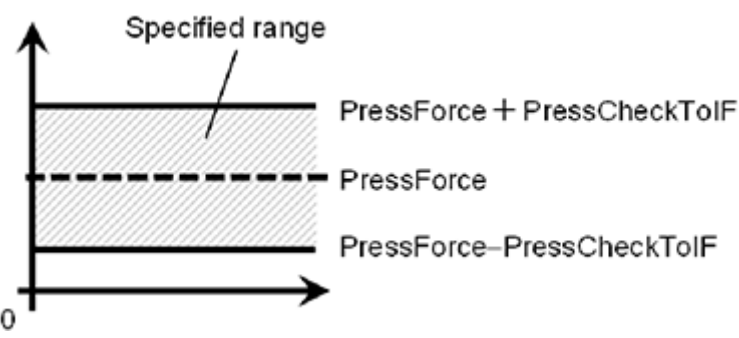
Properties	Description, setting guide
PressCheckToIF	This property sets the pressing direction range of the end conditions related to force. Set a range of the end conditions. PressCheckToIF is applied for Fx, Fy, and Fz. It monitors that the force of directions specified by PressOrient of Fx, Fy, and Fz are within the range of PressForce- PressCheckToIF to PressForce + PressCheckToIF. The following is an image of InsertCheckToIF. 

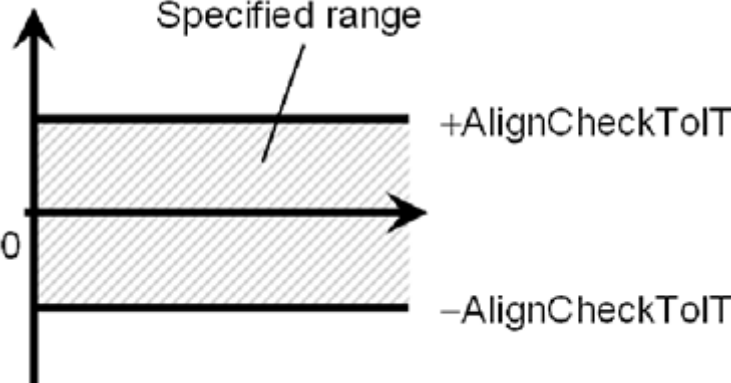
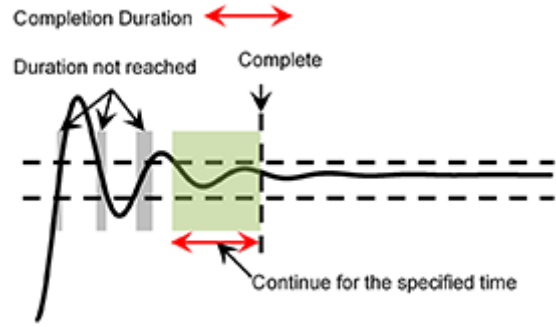
Properties	Description, setting guide
AlignCheckToIT	<p>This property sets the range in the follow direction of the end conditions related to force.</p> <p>AlignCheckToIT is applied for Tx, Ty, and Tz</p> <p>It monitors that the torque of directions specified by AlignOrient of Tx, Ty, and Tz are within the range of - AlignCheckToIT to + AlignCheckToIT.</p> <p>The following is an image of AlignCheckToIT.</p>  <p>The diagram shows a vertical axis with an upward arrow and a horizontal axis with a rightward arrow. The origin is labeled '0'. Two horizontal lines are drawn parallel to the horizontal axis, one above and one below the origin. The region between these two lines is shaded with diagonal lines and labeled 'Specified range'. The upper line is labeled '+AlignCheckToIT' and the lower line is labeled '-AlignCheckToIT'.</p>
HoldTimeThresh	<p>Set the duration time which is used to determine whether the end conditions have satisfied.</p> <p>As shown below, if the specified condition continues for the time specified by HoldTimeThresh, it is determined as the end conditions are satisfied.</p>  <p>The diagram shows a signal waveform on a coordinate system. A horizontal dashed line represents the threshold level. The signal starts below the threshold, crosses it, and then oscillates around it. A green shaded area is shown between the signal and the threshold line, starting from the point where the signal first crosses the threshold and ending at a point where the signal has remained above the threshold for a certain duration. This duration is labeled 'Completion Duration' with a red double-headed arrow. The area before the green shading is labeled 'Duration not reached' and the area after is labeled 'Complete'. A red double-headed arrow below the green area is labeled 'Continue for the specified time'.</p> <p>Normally, set to a short time close to "0".</p> <p>We recommend setting the time according to the actual result.</p>

Step 6. Set end conditions about position

Set property (DistCheckToI) related to the end conditions of the positions.

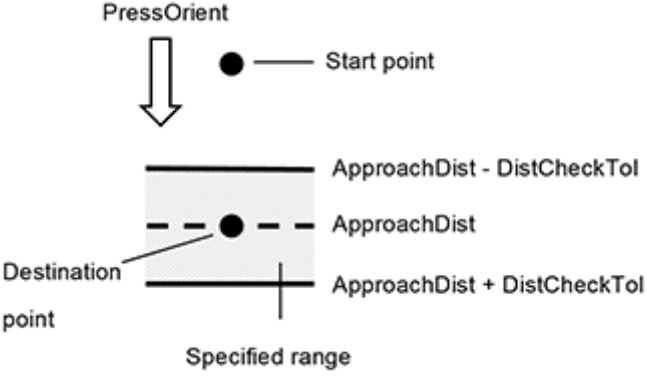
Properties	Description, setting guide
DistCheckTol	<p>This property sets the inserting direction range of the end conditions related to position. It monitors that the moving distance from the operation start point to the destination point in the direction specified by PressOrient is within the range of ApproachDist - DistCheckTol to ApproachDist + DistCheckTol</p> <p>The following is an image of DistCheckTol.</p> 

4.4.3.3.2 Details on properties of Paste object

- **Name Property**
 This property sets a particular name that is assigned to force guide object.
 This property sets a particular name that is assigned to force guide object. Automatically assigned name is added a number after Paste (e.g. Paste01).
 You can change the name. Set up 16 characters at the maximum. Please use alphanumeric characters and underscores [_].
 Note: The initial character cannot be a numeric character.
- **Description Property**
 This property sets descriptions about force guide objects.
 You can set the character string up to 255 characters.
- **StepID Property**
 This property sets StepID during the execution of the force guide objects. It is only used when AutoStepID is False.

	Value
Minimum Value	0
Maximum value	32767

Default: Automatically set according to the numbers of the force guide sequence and the force guide object.

- **AbortSeqOnFail Property**
 This property sets operations when force guide object fails.
 When True is specified: If the force guide object fails, the program ends the force guide sequence and proceeds to the next SPEL statement.
 When specifying False: If force guide object fails, the program proceeds to the next force guide object without ending the force guide sequence.
 Use this property when you want to continue the force guide sequence (e.g. the recovery processes are included in the force guide sequence when the force guide object fails.)

Value	Description
True	Abort the force guide sequence when the force guide object fails.
False	Start the next force guide sequence when the force guide object fails.

Default: True

■ PressOrient Property

This property sets the direction of motion for pasting operations in the coordinate system specified by the ForceOrient property for the force guide sequence.

Value	Description
+Fx	Sets the direction of motion to the +Fx direction in the specified coordinate system.
-Fx	Sets the direction of motion to the -Fx direction in the specified coordinate system.
+Fy	Sets the direction of motion to the +Fy direction in the specified coordinate system.
-Fy	Sets the direction of motion to the -Fy direction in the specified coordinate system.
+Fz	Sets the direction of motion to the +Fz direction in the specified coordinate system.
-Fz	Sets the direction of motion to the -Fz direction in the specified coordinate system.

Default: +Fz

■ PressForce Property

This property sets the pressing force in the direction of motion specified by the PressOrient property for the force guide object during the execution of the force guide object.

- If PressOrient is +Fx, +Fy, +Fz:

	Value (unit: [N])
Minimum Value	-50
Maximum value	0

Default: -10

- If the PressOrient is -Fx, -Fy, or -Fz:

	Value (unit: [N])
Minimum Value	0
Maximum value	50

Default: 10

■ PressFirmnessF Property

This property sets the firmness in relation to the force control function in the direction of motion specified by the PressOrient property for the force guide object during the execution of the force guide object.

The larger the PressFirmnessF value, the stronger the force control function becomes in the direction of motion. This slows response to changes in force, but reduces vibration.

The smaller the PressFirmnessF value, the weaker the force control function becomes in the direction of motion. This speeds up response to changes in force, but increases vibration.

	Value
Minimum Value	0.1
Maximum value	10

Default: 3

■ **AlignEnabled Property**

This property sets whether to execute surface alignment.

Value	Description
True	Executes surface alignment.
False	Does not execute surface alignment.

Default: True

■ **AlignOrient Property**

This property sets the translational and rotational following orientation set for paste operations.

This property is set automatically based on the direction of motion set by the PressOrient property for the force guide object. It cannot be edited.

Value	Description
TyTz	Motion following in the TyTz direction.
TxTz	Motion following in the TxTz direction.
TxTy	Motion following in the TxTy direction.

Default: TxTy

■ **AlignFirmnessT Property**

This property sets the firmness in relation to the force control function for torque in the following direction during the execution of the force guide object.

The larger the AlignFirmnessT value, the stronger the force control function becomes in the following direction. This slows response to changes in force, but reduces vibration.

The smaller the AlignFirmnessT value, the weaker the force control function becomes in the following direction. This speeds up response to changes in force, but increases vibration.

	Value
Minimum Value	10
Maximum value	100000

Default: 1000

■ **PressCheckToIF Property**

This property sets the tolerance range for the force used as an end condition in the direction of motion specified by the PressOrient property for the force guide object.

This sets the $\text{PressForce} \pm \text{PressCheckToIF}$ range as the end condition.

	Value
Minimum Value	0.1
Maximum value	10

Default: 1

■ **AlignCheckToIT Property**

This property sets the tolerance range for the torque used as an end condition in the rotational direction being followed.

This sets the $\pm \text{AlignCheckToIT}$ range as the end condition.

	Value
Minimum Value	1
Maximum value	10000

Default: 100

■ HoldTimeThresh Property

This property sets the duration time until the determination of the end conditions related to force.

When the specified condition continues for the time specified by HoldTimeThresh, it is determined as the end conditions are satisfied.

	Value (unit: [sec])
Minimum Value	0
Maximum value	10

Default: 0.1

■ ApproachDist Property

This property sets the moving distance from the start point of the force guide object to the start point of the paste operation.

	Value (Unit: [mm])
Minimum Value	0
Maximum value	50

Default: 10

■ DistCheckTol Property

Specify the range that is the success condition (when the operation is finished) of the distance moved from the operation start position.

This sets the ApproachDist ± DistCheckTol range as the success condition.

	Value
Minimum Value	0.01
Maximum value	10

Default: 1

■ Timeout Property

This property sets the time-out period of the force guide object.

When the robot does not satisfy the conditions enabled by PressForce, PressCheckToIF, and AlignCheckToIT even the time specified by Timeout has passed, it determines as failure of the Paste object.

After the determination, end the force guide sequence according to AbortSeqOnFail or proceed to the next force guide object.

	Value (unit: [sec])
Minimum Value	0.1
Maximum value	60

Default: 10

4.4.3.3.3 Details on results of Paste object

■ EndStatus Result

It is a result of the execution.

It will be succeeded when satisfying "success conditions" described in

Paste Object

Value	Description
Passed	Force guide object is succeeded.

Value	Description
Failed	Force guide object is failed.
NoExec	Force guide object is not executed.
Aborted	Aborted during the execution of force guide object.

▪ Time Result

This is the time required for execution.

Unit: [sec]

▪ TimedOut Result

Shows whether the time-out period set in the Timeout property was reached.

Value	Description
True	Reached the time-out period.
False	End before reaching to the time-out period.

▪ EndForces Result

It is force and torque when force guide object ends. Acquire values of Fx, Fy, Fz, Tx, Ty, and Tz.

Unit: Fx, Fy, Fz [N] / Tx, Ty, Tz [N · mm]

▪ EndPos Result

Positions when the force guide object ends. Acquire values of X, Y, Z, U, V, and W.

Unit: X, Y, Z [mm] / U, V, W [deg]

▪ AvgForces Result

Average values of force and torque during the force guide object execution. Acquire values of Fx, Fy, Fz, Tx, Ty, and Tz.

Unit: Fx, Fy, Fz [N] / Tx, Ty, Tz [N · mm]

▪ PeakForces Result

Peak values of force and torque during the force guide object execution. The peak value is a value which absolute value is the largest. Acquire values of Fx, Fy, Fz, Tx, Ty, and Tz.

Unit: Fx, Fy, Fz [N] / Tx, Ty, Tz [N · mm]

▪ ForceCondOK Result

Shows whether the end conditions related to force were satisfied.

Value	Description
True	Satisfy the end conditions related to force.
False	The end conditions related to force are not satisfied.

▪ TriggeredForces Result

It is the force and torque when satisfying the end conditions related to force. Acquire values of Fx, Fy, Fz, Tx, Ty, and Tz.

Unit: Fx, Fy, Fz [N] / Tx, Ty, Tz [N · mm]

▪ TriggeredPos Result

Positions when satisfying the end conditions related to force. Acquire values of X, Y, Z, U, V, and W.

Unit: X, Y, Z [mm] / U, V, W [deg]

▪ PosCondOK Result

Shows whether the end conditions related to position were satisfied.

Value	Description
True	Satisfy the end conditions related to position.
False	The end conditions related to position are not satisfied.

- PosLimited Result

This shows whether the limit range related to position was exceeded.

Value	Description
True	Exceed the limit range related to position.
False	The limit range related to position is not exceeded.

4.4.3.4 Adjustment Guidelines for the Paste sequence and Object Property Values

The following section describes how to adjust when using Paste sequence and objects.

- If GeneralObjectFailed appears as the FailedStatus result:
A failure has occurred with a general object placed in the Paste sequence.
The last executed object appears in the LastExecObject result. Adjust the property of the object that appears here by referring to the property setting guideline or adjustment guideline for the property.
- If ForceConditionFailed appears as the FailedStatus result:
Decrease the Firmness value of the paste or rotational direction.
However, the robot motion may be easy to vibrate. Please perform proper adjustments for your operations.
To adjust the Firmness, we recommend changing the value gradually (e.g. decrease the value by 10% from its current state).
If decreasing Firmness does not refine, increase Timeout.
- If PosConditionFailed appears as the FailedStatus result:
A failure has occurred because the position did not meet the position success condition set by the object during Paste object execution.
Check that the ApproachDist value is not too large compared to the actual operating environment.
- If Overrun appears as the FailedStatus result:
Even though the position exceeded the position success condition range set by the object during Paste object execution, a position overrun was detected and a failure has occurred because the motion executed without enough force to satisfy the force success condition.
Check that the ApproachDist value is not too small compared to the actual operating environment.
- When it takes time to align a surface:
Decrease the value of AlignFirmnessT or increase the value of PressForce.
However, decreasing the value of AlignFirmnessT may result in the vibration of the robot motion. Please perform proper adjustments for your operations.
To adjust the AlignFirmnessT, we recommend adjusting the value gradually (e.g. change the value by 10% from its present value).
If increasing the value of PressForce, applied force to workpiece will be large. Set a proper value for your workpiece.
If the contact surface of the workpiece is small, torque when pressing will be small. If the torque is small, rotational speed will be slow depending on the force control functions. Therefore, even adjusting the above two properties, the operation will not be able to finish in the specified time.
- When the robot motion vibrates:
Increase the PressFirmnessF or AlignFirmnessT value.
Adjust Firmness value in the direction where is vibrating.
However, response of the robot will be slow. Please perform proper adjustments for your operations.
To adjust the Firmness, we recommend changing the value gradually (e.g. increase the value by 10% from its present state).

- When the robot bounces largely in the pressing direction:

If the robot repeatedly bounces largely in a few seconds, the robot motion may be restricted by `LimitAccelS` of the force guide sequence.

Also, it likely to happen during the execution in low power mode.

If the robot still bounces even executing in high power mode, increase the value of `LimitAccelS`. If the robot still bounces, decrease the value of `PressFirmnessF`.
- When the Paste object ends when aligning a surface:

If the specified time is not enough, increase the value of `Timeout`.

When the end conditions are satisfied even the surface is not aligned, decrease the value of `AlignCheckToIT`. If it does not work, set `HoldTimeThresh`.

If the contact surface of the workpiece is small, torque when pressing will be small. Therefore, the object will be within the range specified by `AlignCheckToIT` even the surfaces are not aligned. In this case, decrease the value of `AlignCheckToIT` or Disabled the `ForceCheckEnabled`. Please consider to manage by the execution time specified by `Timeout`.

4.4.4 ScrewTighten Sequence and Object

The `ScrewTighten` sequence is a function used to move the robot by pressing in a specified direction with a specified amount of force. This is used for screw tightening using an electric screwdriver that can operate I/O. Furthermore, if the screw is jammed while screw tightening and the screw is not tightened correctly, it is possible to retighten the screw.

A `ScrewTighten` sequence is composed of two objects - a `ScrewTighten` object and a `ScrewRetighten` object. General force guide objects can also be added depending on the work procedure.

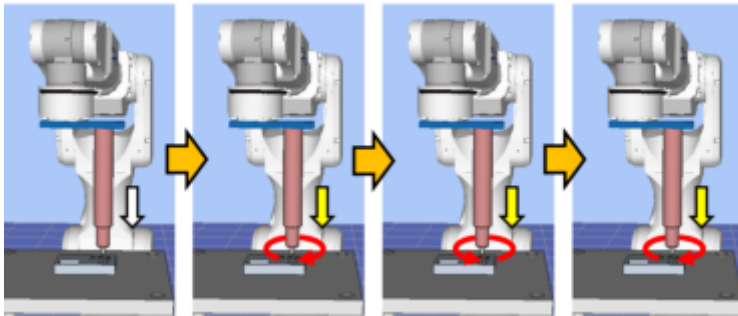

The diagram above provides a visual representation of a `ScrewTighten` object.

Executed from a non-contact state, this object moves the robot in the screw tightening direction depicted by the white arrow. From the point of contact, the robot tightens screws with a set amount of force in the screw tightening direction shown by the yellow arrow. The motion procedure up to this point is executed by a `ScrewTighten` object.

After this, if the screw is not tightened correctly, the robot continues to apply a set amount of force to loosen the screw and then retighten in the screw tighten direction as shown by the yellow arrow. This motion is executed by a `ScrewRetighten` object.

This chapter covers the sequence wizards and properties of `ScrewTighten` sequence, `ScrewTighten` objects, and `ScrewRetighten` objects, and describes how to configure them.

For more information about general force guide objects, see the next section.

Software [General force guide object](#)

4.4.4.1 Sequence Wizard for a ScrewTighten Sequence

Use the sequence wizard to create a `ScrewTighten` sequence. This sequence wizard can be displayed by doing the following.

- Right click the sequence flow in the flowchart, or the sequence node in the sequence tree, and then select [Sequence Wizard].

- Click the  button shown to the right of the [Click to open->] Wizard setting in the ScrewTighten sequence property.

When the sequence wizard appears, configure settings as instructed on the screen.

The sequence wizard for a ScrewTighten sequence can also be configured on the new sequence screen for creating a new force guide sequence. For more information, see the following section.

Software [Force Guidance] [\[Tools\] menu](#)

- Create a new force guide sequence - Sequence Wizard, Create a new system force guide sequence

Step 1. Set screw parameters

Select the hand number you plan to use for the ScrewTighten sequence, ScrewTighten object, and ScrewRetighten object, and set the screwdriver and screw.

The robot operating speed during screw tightening is determined by the rotational speed of the screwdriver and the lead length of the screw.

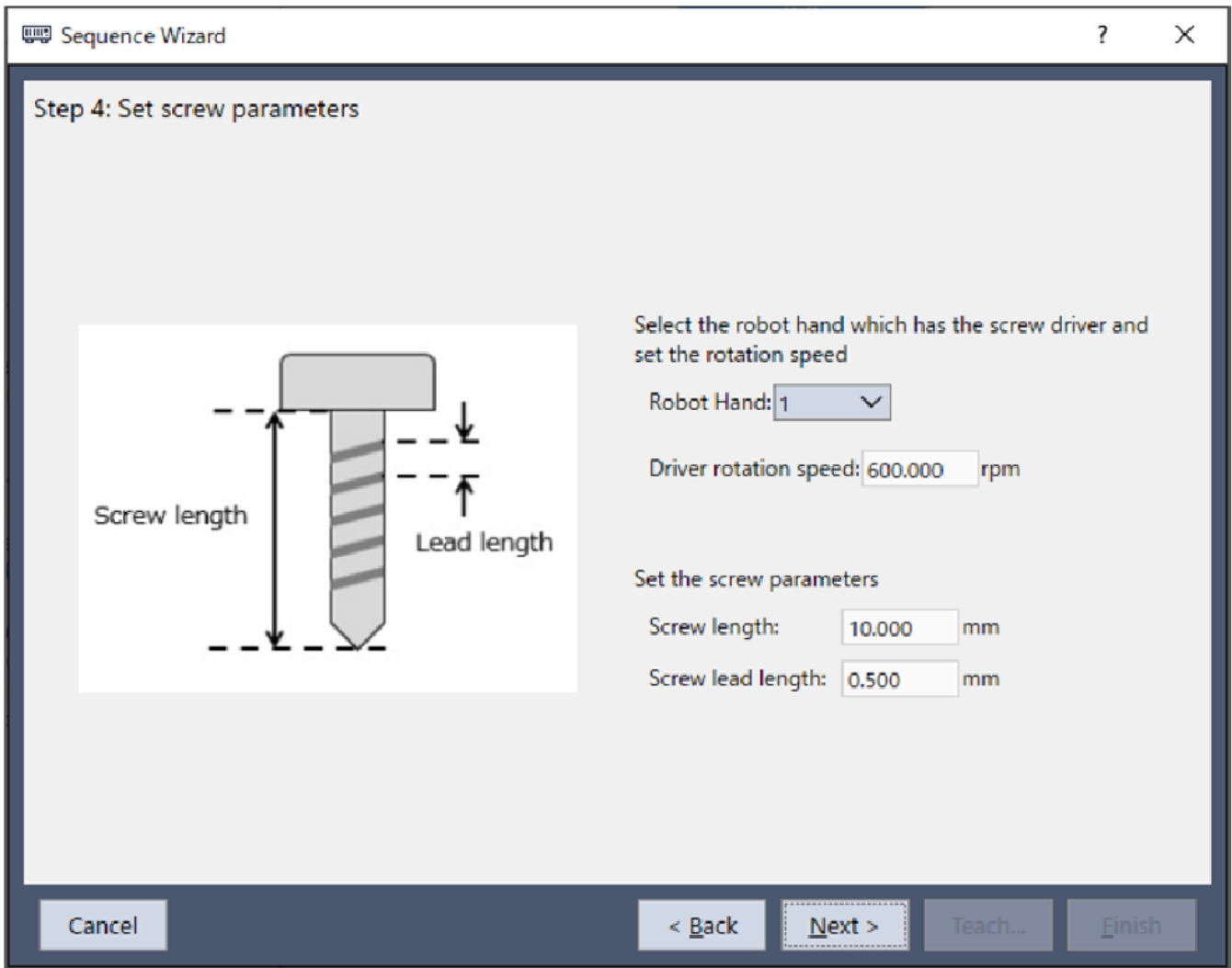

Item	Description, setting guide
Robot Hand	Select the robot hand number to be used. A label is displayed on the set robot hand. To set a new tool, use Robot Manager. For more information about the robot hand setting, see the following manual. "Hand Function Manual" Minimum value: 1 Maximum value:15 Default: 1

Item	Description, setting guide
Driver rotation speed	Set driver rotation speed. Minimum value: 10.000[rpm] Maximum value: 2000.000[rpm] Default: 600.000[rpm]
Screw length	Set screw length. Minimum value: 1.000 [mm] Maximum value: 100.000 [mm] Default: 10.000[mm]
Screw lead length	Set screw lead length. Minimum value: 0.100 [mm] Maximum value: 6.000 [mm] Default: 0.500[mm]
[Cancel] button	Cancels a new ScrewTighten sequence creation. Click it to end a sequence wizard.
[Back] button	When opening from the new sequence creation screen, you can return to the previous Step.
[Next] button	Proceeds to the next Step.
[Finish] button	You cannot click this button.

Step 2. Select the robot tool to use for the end effector

Select the tool number to be used for the ScrewTighten sequence, ScrewTighten object, and ScrewRetighten object.

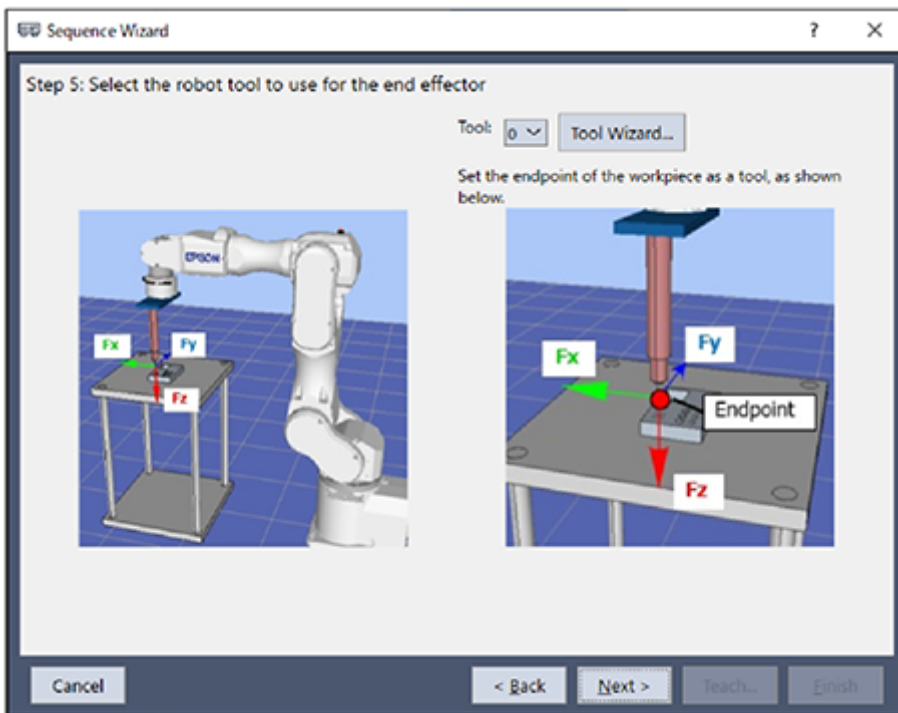

Item	Description, setting guide
Tool	Select the tool number to be used. Select a tool number so that the end point of the workpiece is at the tool origin point. Tool numbers set are sorted in the list. To set a new tool, use the Tool Wizard button. "Epson RC+ 8.0 User's Guide - Epson RC+ 8.0 GUI - [Tools] menu, [Tools] - [Robot Manager] - [Tool Settings] panel" Minimum value: 0 Maximum value: Maximum value for the set tool number Default: 0
[Cancel] button	Cancels a new ScrewTighten sequence creation. Click it to end a sequence wizard.
[Back] button	When opening from the new sequence creation screen, you can return to the previous Step.
[Next] button	Proceeds to the next Step.
[Finish] button	You cannot click this button.

Step 3. Set tool offsets

When the tool set in Step 2 is not set in the center of the workpiece tip, this setting is required. Set the offset amount from the tool to the center of the workpiece tip.

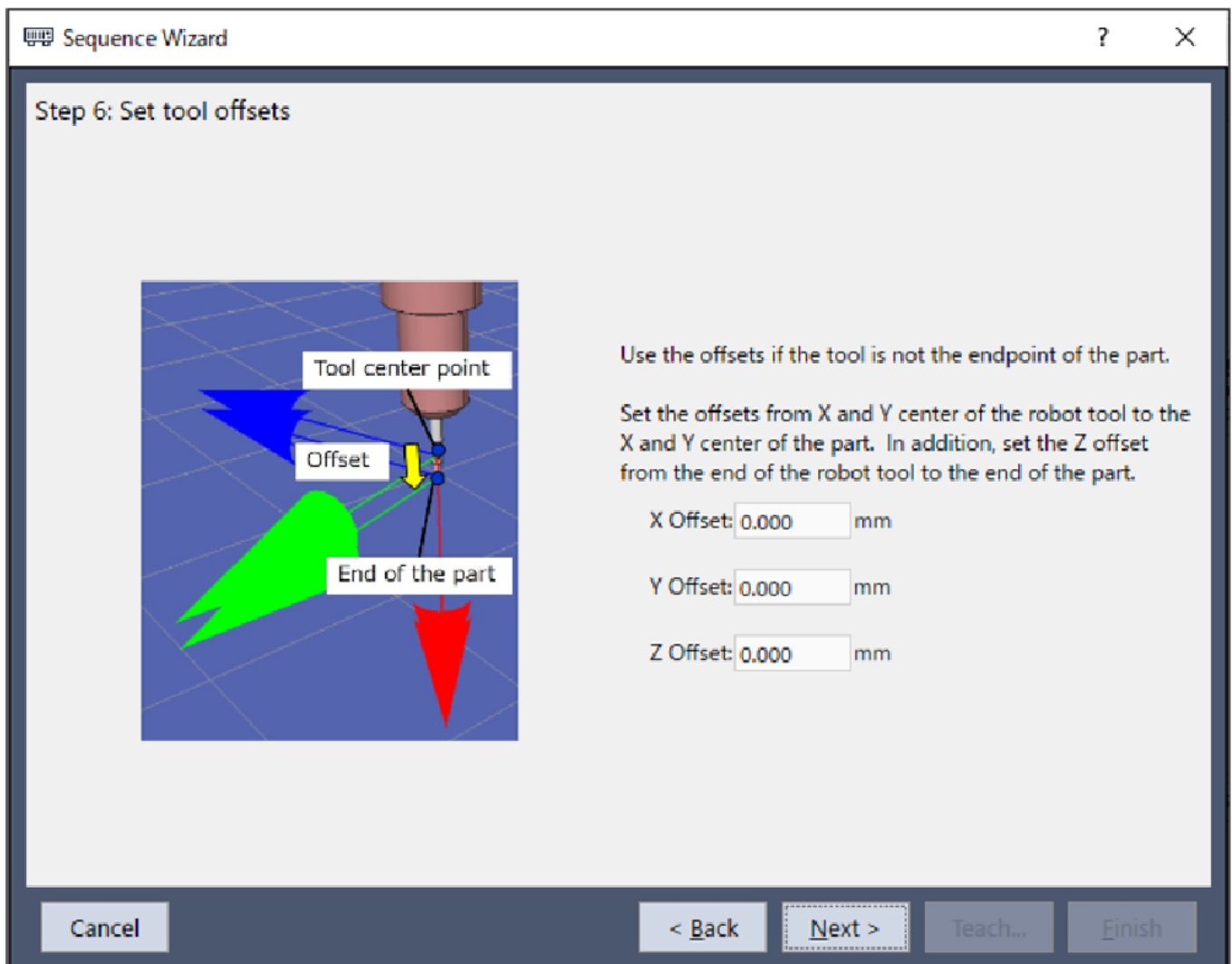

Item	Description, setting guide
X Offset	Sets the offset amount in the X direction from the tool set in Step 1 to the tip of the workpiece. Minimum value: -2000.000 [mm] Maximum value: 2000.000 [mm] Default: 0.000[mm]
Y Offset	Sets the offset amount in the Y direction from the tool set in Step 1 to the tip of the workpiece. Minimum value: -2000.000 [mm] Maximum value: 2000.000 [mm] Default: 0.000[mm]
Z Offset	Sets the offset amount in the Z direction from the tool set in Step 1 to the tip of the workpiece. Minimum value: -2000.000 [mm] Maximum value: 2000.000 [mm] Default: 0.000[mm]
[Cancel] button	Cancels a new ScrewTighten sequence creation. Click it to end a sequence wizard.
[Back] button	Returns to the previous Step.
[Next] button	Proceeds to the next Step.
[Finish] button	You cannot click this button.

Step 4. Set the screw tighten operation coordinate system and direction

Set the screw tighten direction.

Select "Tool" to perform the screw tighten operation that matches the orientation when starting the sequence.

Select "Base or Local" to perform the screw tighten operation in the direction that matches the workpiece regardless of the

orientation when starting the sequence.

Sequence Wizard

Step 7: Set the screw tighten operation coordinate system and direction

Drive the screw in the tool coordinate system
 Drive the screw in the selected base or local coordinate system

Robot local: Base

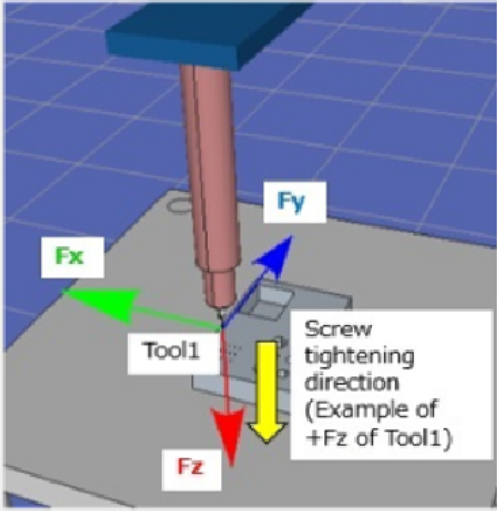
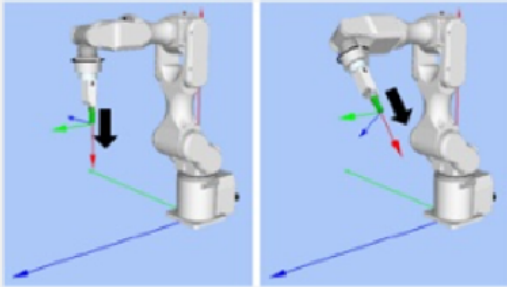

Screw tighten direction: +Fz

Tool1

Screw tightening direction (Example of +Fz of Tool1)

Fx

Fy

Fz

Cancel < Back Next > Teach... Finish

Item	Description, setting guide
Robot local	<p>Select the coordinate system used by the ScrewTighten sequence.</p> <p>When the screw tighten coordinate system is set to "Base" or "Local", the robot will move in the corresponding coordinate system. Select the coordinate system according to the orientation of the workpiece being inserted.</p> <p>Minimum value: Base (0)</p> <p>Maximum value: 15</p> <p>Default: Base</p>
Screw tighten direction	<p>Select the direction of screw tightening.</p> <p>When the screw tighten coordinate system is set to "Tool", the ScrewTighten sequence and ScrewTighten object will move in the direction of screw tightening selected for the tool coordinate system set in Step 2.</p> <p>When the screw tighten coordinate system is set to "Base" or "Local", the ScrewTighten sequence and ScrewTighten object will move in the direction of screw tightening selected for the base or local coordinate system set as the coordinate system.</p> <p>Values: +Fx, -Fx, +Fy, -Fy, +Fz, -Fz</p> <p>Default: +Fz</p>
[Cancel] button	<p>Cancels a new ScrewTighten sequence creation.</p> <p>Click it to end a sequence wizard.</p>
[Back] button	<p>Returns to the previous Step.</p>
[Next] button	<p>Proceeds to the next Step.</p>
[Finish] button	<p>You cannot click this button.</p>

Step 5. Select whether to enable screw retightening

Select whether to enable screw retightening.

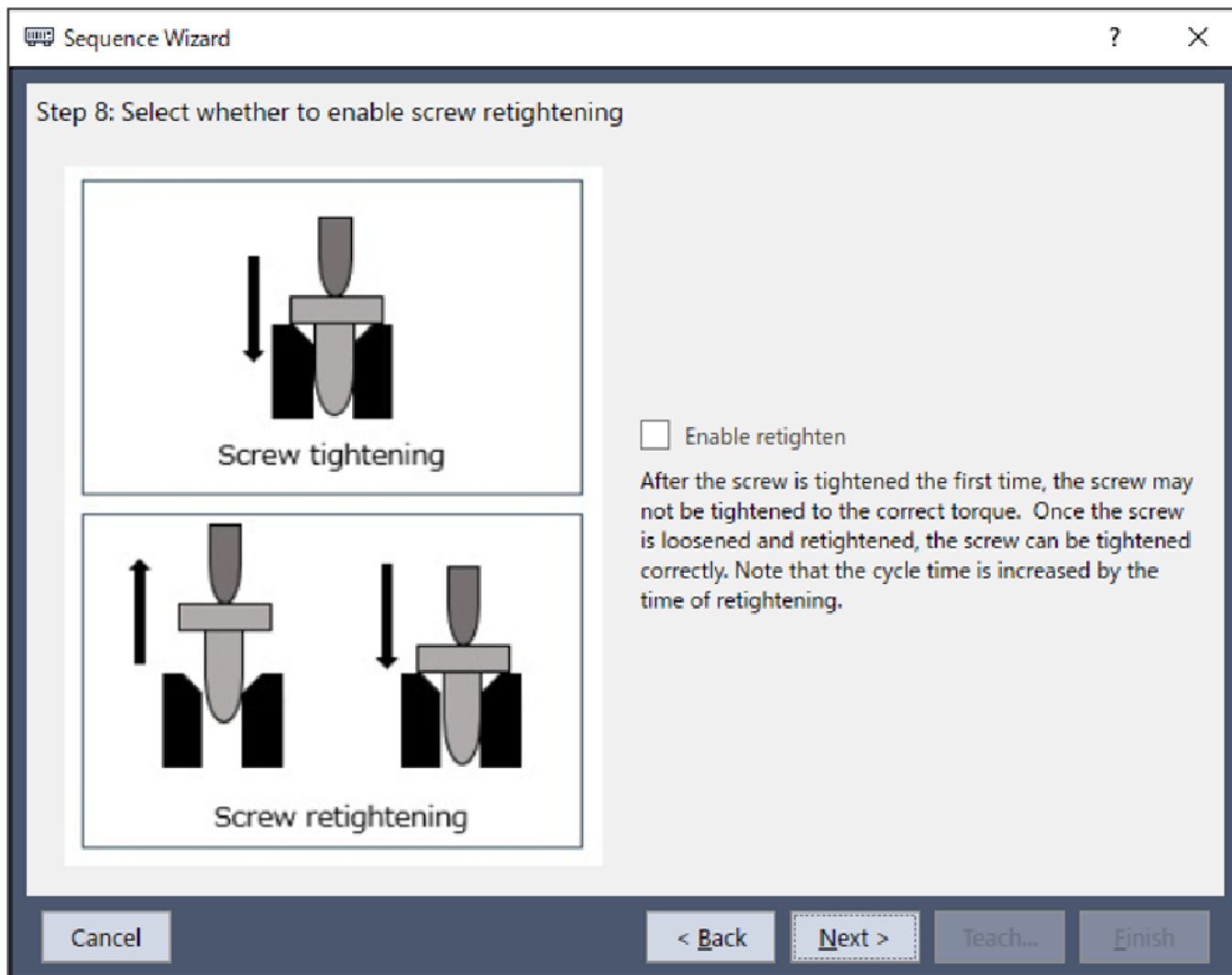

Item	Description, setting guide
Enable retighten	Set whether to retighten the screw. When enabled, if the screw is not tightened properly, loosen it and retighten it. Retightening may tighten the screw correctly, but the cycle time will increase. Default: Disabled
[Cancel] button	Cancels a new ScrewTighten sequence creation. Click it to end a sequence wizard.
[Back] button	Returns to the previous Step.
[Next] button	Proceeds to the next Step.
[Finish] button	You cannot click this button.

Step 6. Set the approach distance for the screw driving operation

Set the approach distance for the screw driving.

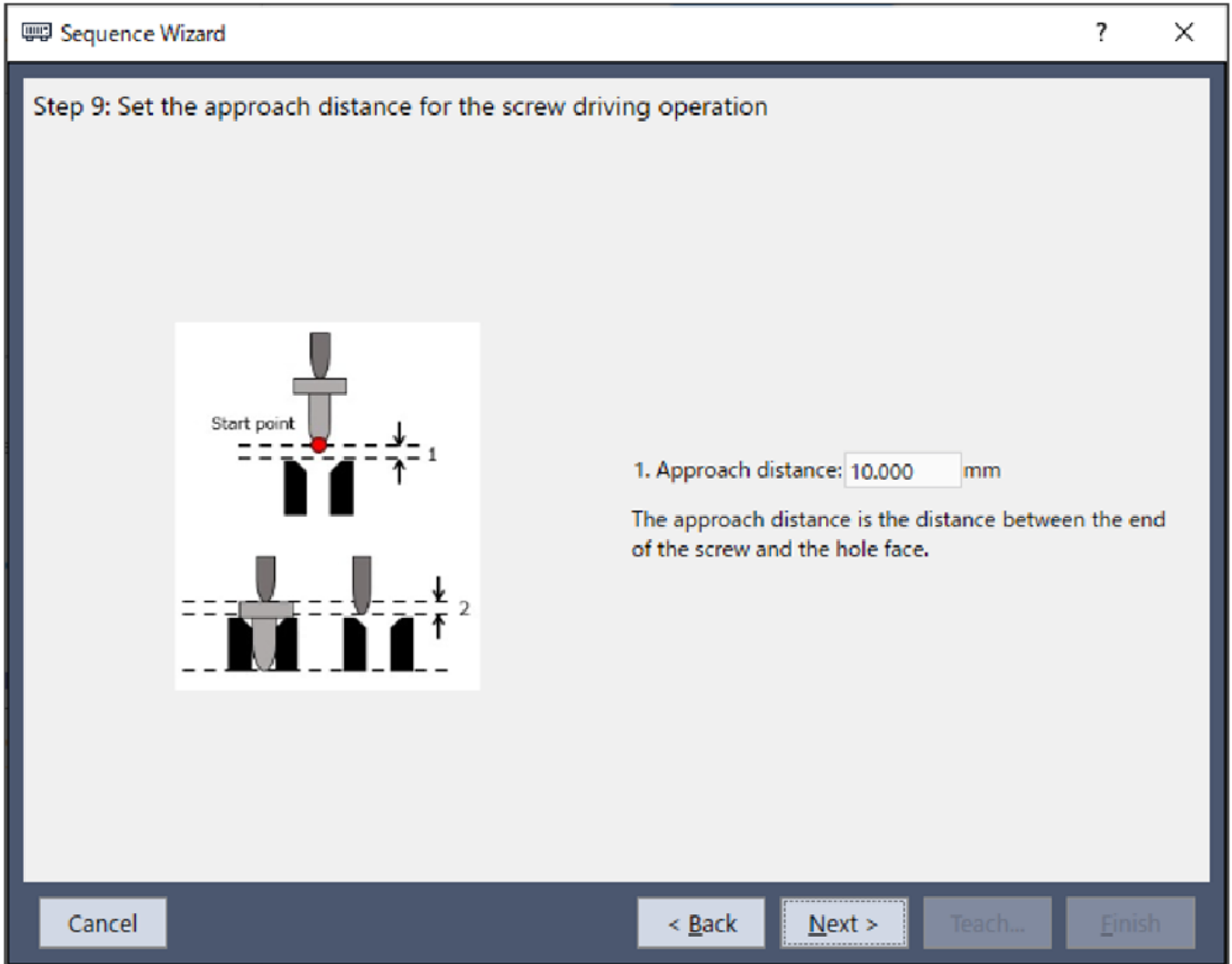

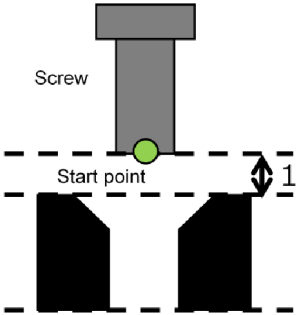
Item	Description, setting guide
Approach distance	<p>Set an approach distance.</p> <p>The approach distance is the distance 1 depicted in the diagram below, which is the distance between the end point of the gripped screw at the start of the ScrewTighten sequence indicated by the green dot in the diagram, and the opening of the screw hole.</p> <p>Teach the robot a start point of the motion that shortens the approach distance as much as possible. As the force control function is slower than position control, longer approach distances will result in longer cycle times.</p>  <p>Minimum value: 0.000 [mm] Maximum value: 50.000 [mm] Default: 10.000[mm]</p>

Item	Description, setting guide
[Cancel] button	Cancels a new ScrewTighten sequence creation. Click it to end a sequence wizard.
[Back] button	Returns to the previous Step.
[Next] button	Proceeds to the next Step.
[Finish] button	You cannot click this button.

Step 7. Set the screw driving force required

Set the screw driving force required. While this property setting can be configured directly, this is for advanced users.

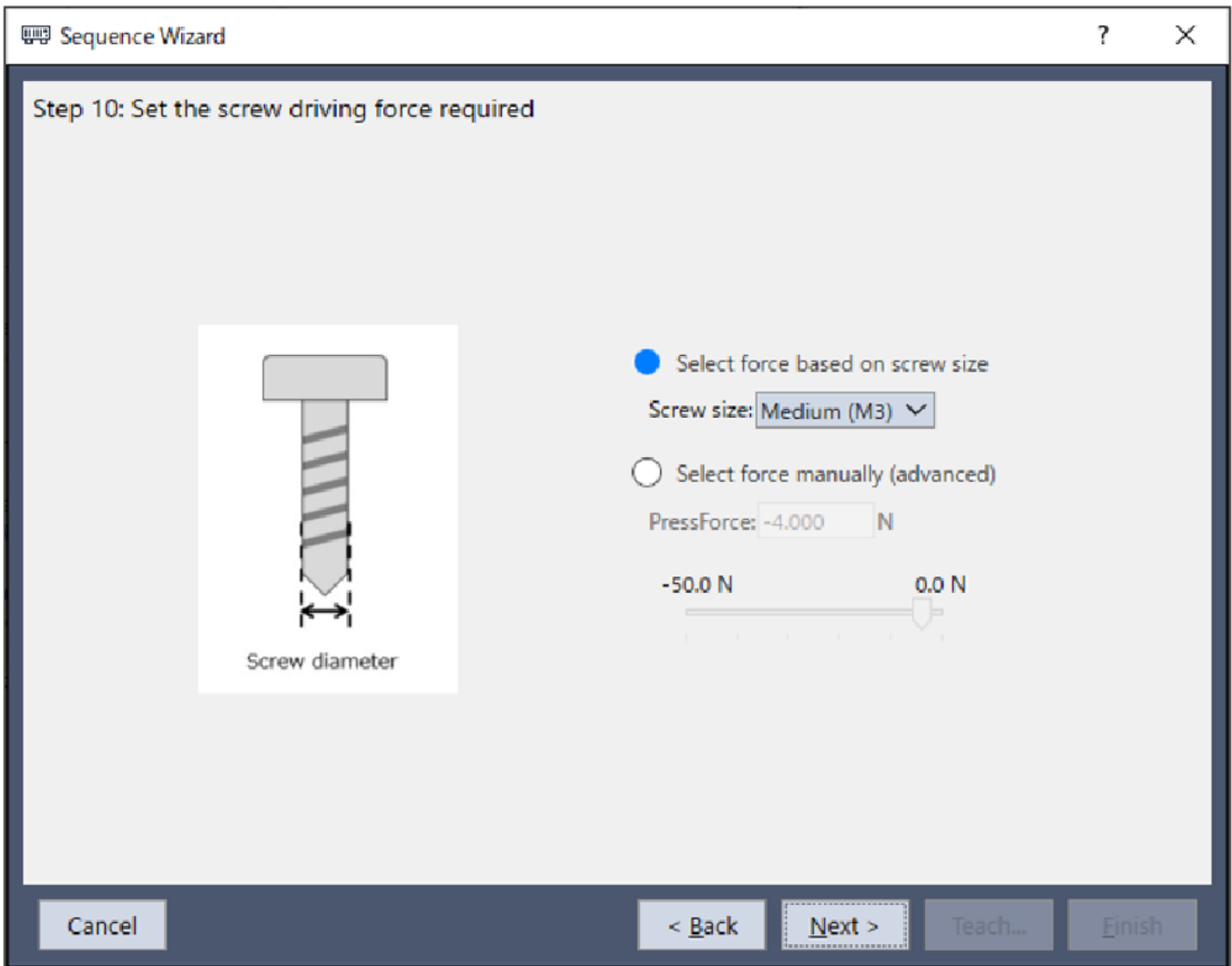

Item	Description, setting guide
Screw size	Set a screw size. Choose from three presets, "Small", "Medium", and "Large". A guideline for the screw size to choose from is provided below. Small: M1.5 Medium: M3 Large: M6

Item	Description, setting guide
PressForce	<p>Set a pressing force to apply in the direction of screw tightening. The actual force will be greater than the force set due to friction between the screw and the screw hole while tightening screw.</p> <p>This can be set by selecting advanced settings.</p> <p>Press the  button to adjust the pressing force using a slider.</p>
	<p>When the screw tightening direction is in the positive direction:</p> <p>Minimum value: -50.0 [N] Maximum value: 0.0 [N] Default: -10.0 [N]</p>
	<p>When the screw tightening direction is in the negative direction:</p> <p>Minimum value: 0.0 [N] Maximum value: 50.0 [N] Default: 10.0 [N]</p>
[Cancel] button	<p>Cancels a new ScrewTighten sequence creation.</p> <p>Click it to end a sequence wizard.</p>
[Back] button	Returns to the previous Step.
[Next] button	Proceeds to the next Step.
[Finish] button	You cannot click this button.

Step 8. Set the end condition for screw tightening force

Set the screw collision detection force.

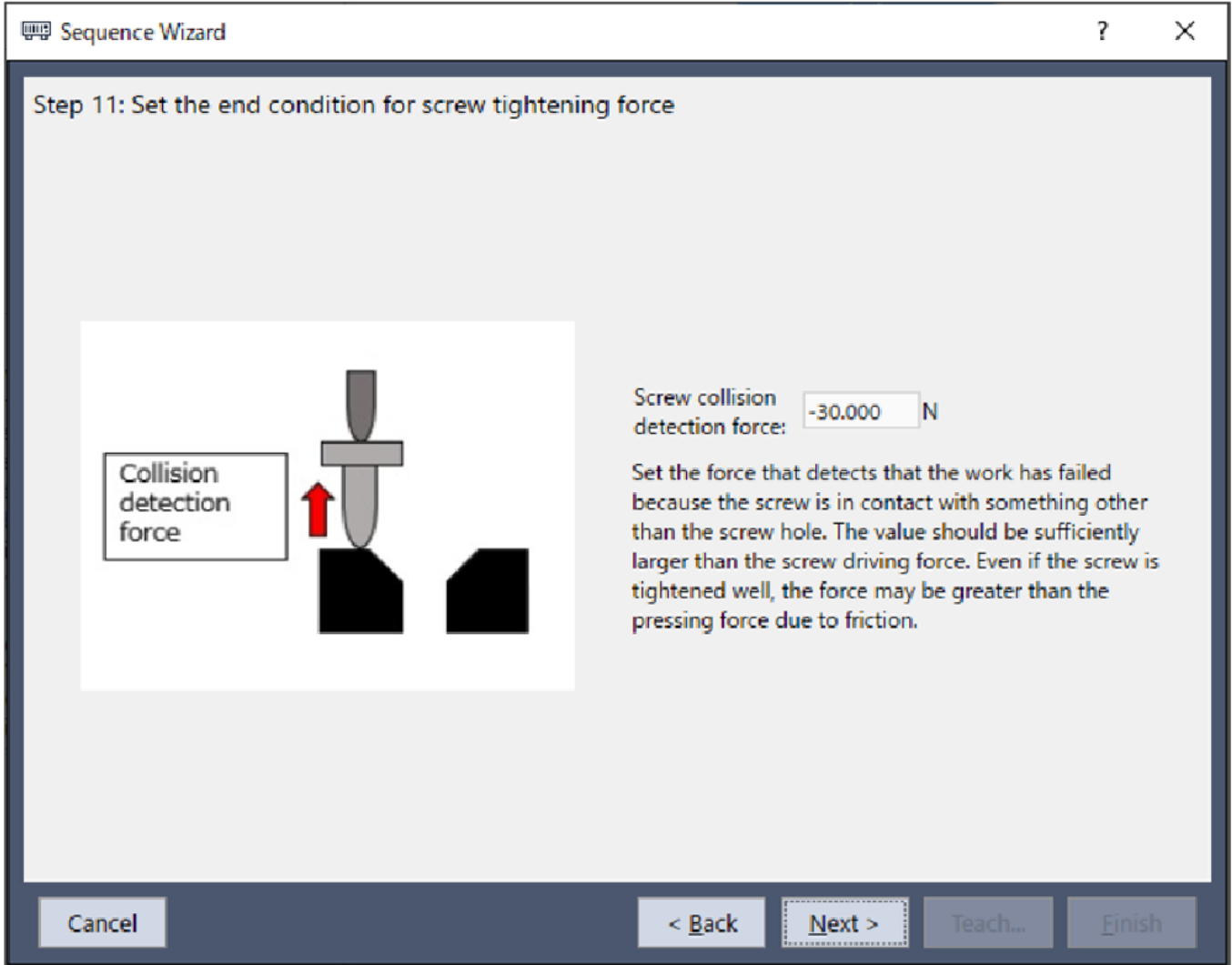

Item	Description, setting guide
Screw collision detection force	<p>Set a screw collision detection force.</p> <p>The screw collision detection force is the size of the force used to determine an operation failure when the screw is pressed against an object other than the screw hole. Set this force to a sufficiently greater value than the screw force set in Step 7. This is because the pressing force may be greater than the force set due to friction between the screw and the screw hole.</p> <p>When the screw tightening direction is in the positive direction: Minimum value: -100.000 [N] Maximum value: -10.000 [N] Default: -30.000 [N]</p> <p>When the screw tightening direction is in the negative direction: Minimum value: 10.000 [N] Maximum value: 100.000 [N] Default: 30.000 [N]</p>
[Cancel] button	<p>Cancels a new ScrewTighten sequence creation.</p> <p>Click it to end a sequence wizard.</p>

Item	Description, setting guide
[Back] button	Returns to the previous Step.
[Next] button	Proceeds to the next Step.
[Finish] button	You cannot click this button.

Step 9. Configure screw retightening operation

Configure screw retightening operation parameters. This settings screen will appear when screw retightening is enabled in Step 5.

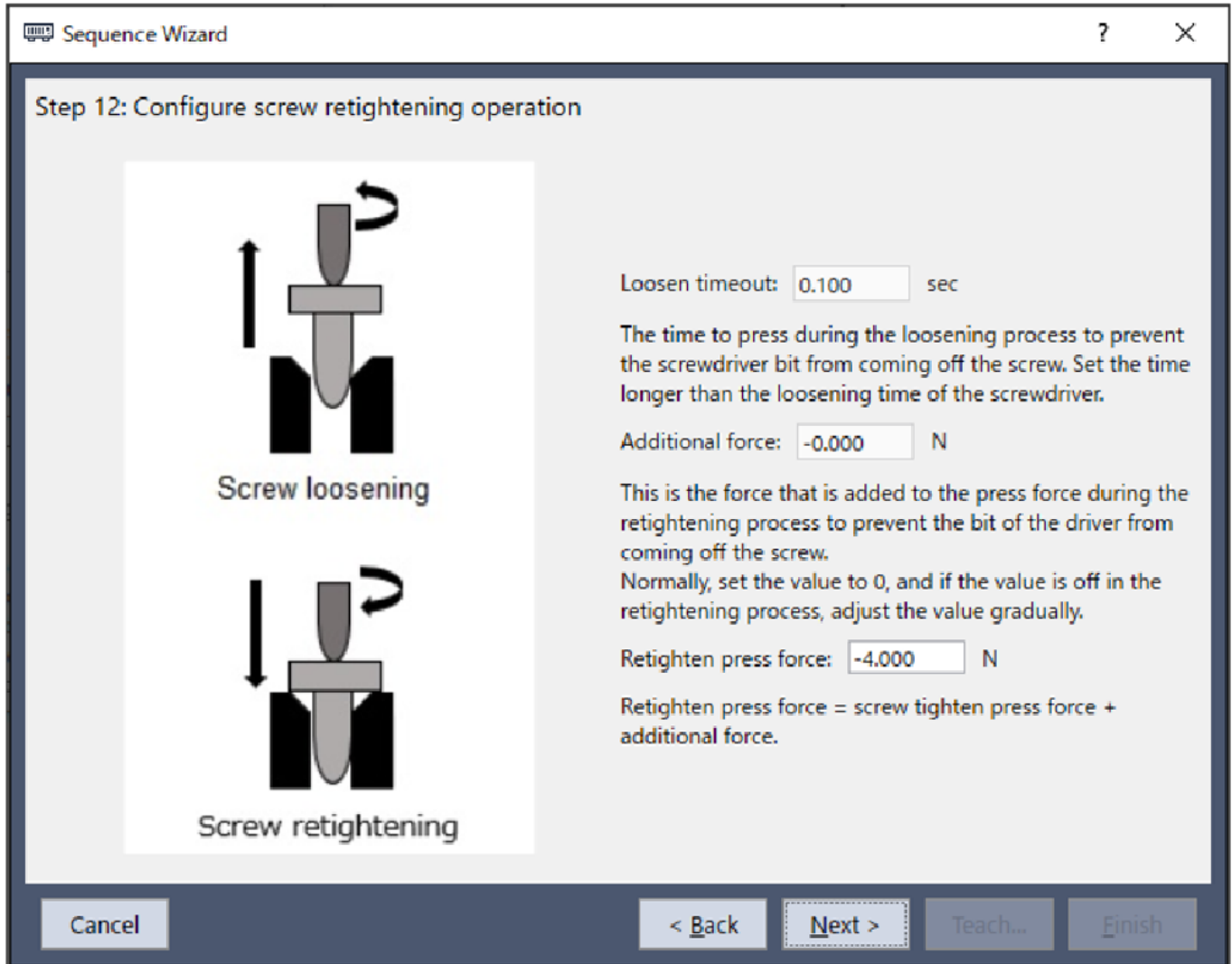

Item	Description, setting guide
Loosen timeout	<p>Set the screw loosening duration.</p> <p>If the screw loosening complete bit is configured for the screwdriver in robot hand settings, screw loosening will stop if the screw loosening complete signal is received before the loosen timeout elapses. Screw loosening will stop regardless of whether a screw loosening complete signal is received when the loosen timeout runs out.</p> <p>Minimum value: 0.000 [sec] Maximum value: 1.000 [sec] Default: 0.100 [sec]</p>

Item	Description, setting guide
Additional force	<p>Set an additional pressing force.</p> <p>The additional force is an additional force to the pressing force set in Step 7 to ensure that the screw does not come out from the screwdriver bit during retightening. Normally, leave the default value of 0. Gradually increase this if the screw comes out during retightening.</p>
	<p>When the screw tightening direction is in the positive direction:</p> <p>Minimum value: -20.000 [N] Maximum value: 0.000 [N] Default: 0.000 [N]</p>
	<p>When the screw tightening direction is in the negative direction:</p> <p>Minimum value: 0.000 [N] Maximum value: 20.000 [N] Default: 0.000 [N]</p>
Retighten press force	<p>This shows the retighten pressing force.</p> <p>The retighten pressing force is calculated by adding the screw tightening pressing force set in Step 7, and the additional force.</p>
[Cancel] button	<p>Cancels a new ScrewTighten sequence creation.</p> <p>Click it to end a sequence wizard.</p>
[Back] button	<p>Returns to the previous Step.</p>
[Next] button	<p>Proceeds to the next Step.</p>
[Finish] button	<p>You cannot click this button.</p>

Step 10. Change Summary

You can see the list of properties that have been changed in the wizard.

This is displayed when you edit the created ScrewTighten sequence in the Sequence Wizard. It is not displayed when creating a new one.

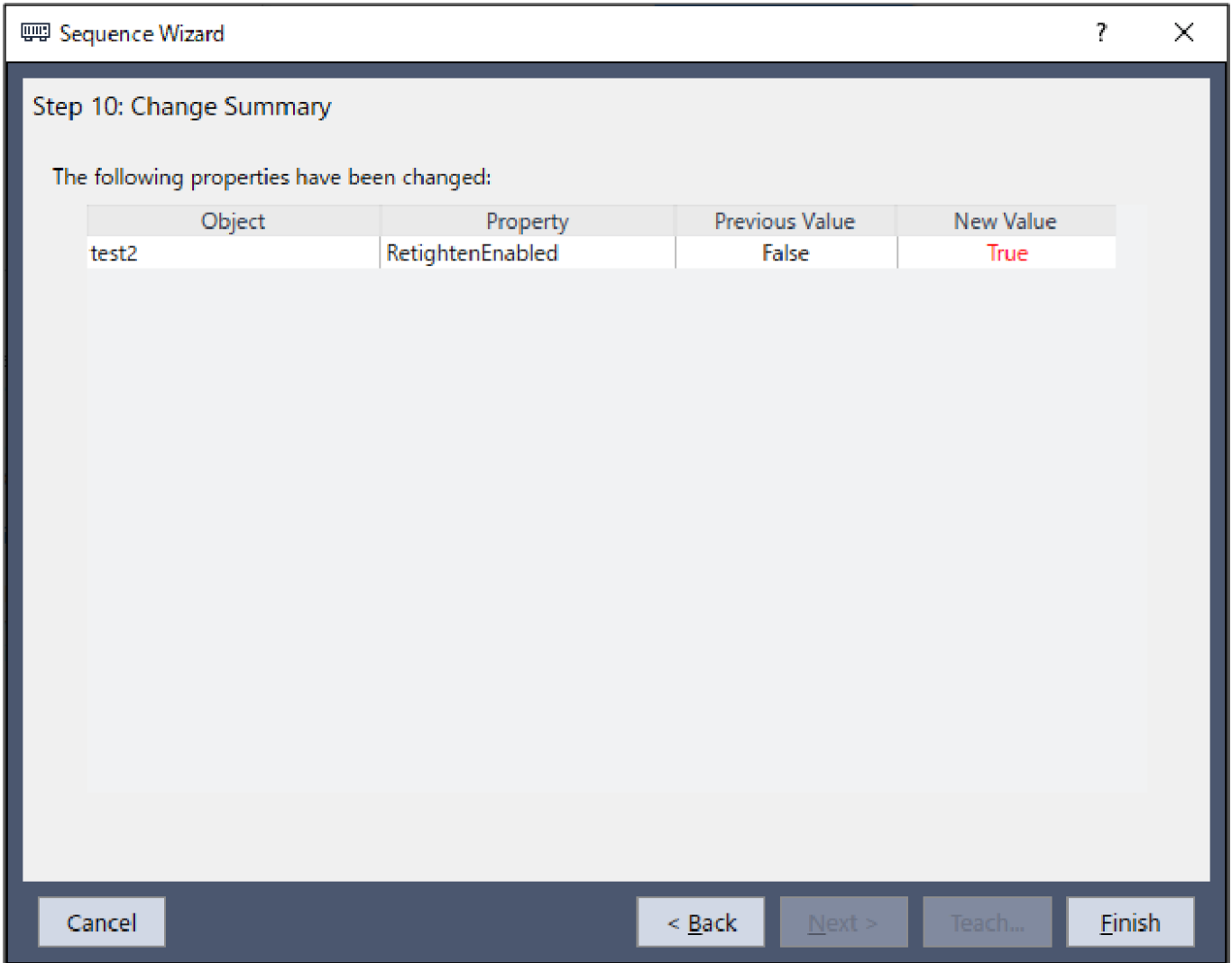

Item	Description
Object Property	Shows which properties of which sequence or object have been changed as a result of changing settings in the wizard.
Previous Value New Value	Shows how the properties have been changed as a result of changing the settings in the wizard.
[Cancel] button	Cancels a new ScrewTighten sequence creation. Click it to end a sequence wizard.
[Back] button	Returns to Step 8 when the screw retightening operation in Step 5 is disabled. Returns to Step 9 when the screw retightening operation in Step 5 is enabled.
[Next] button	You cannot click this button.
[Finish] button	Completes changing the ScrewTighten sequence with the entered contents.

Finish: ScrewTighten Sequence Created

This is the completion screen for the set sequence. You can check the created sequence name and type. The screen is displayed when opening from the new sequence creation screen.

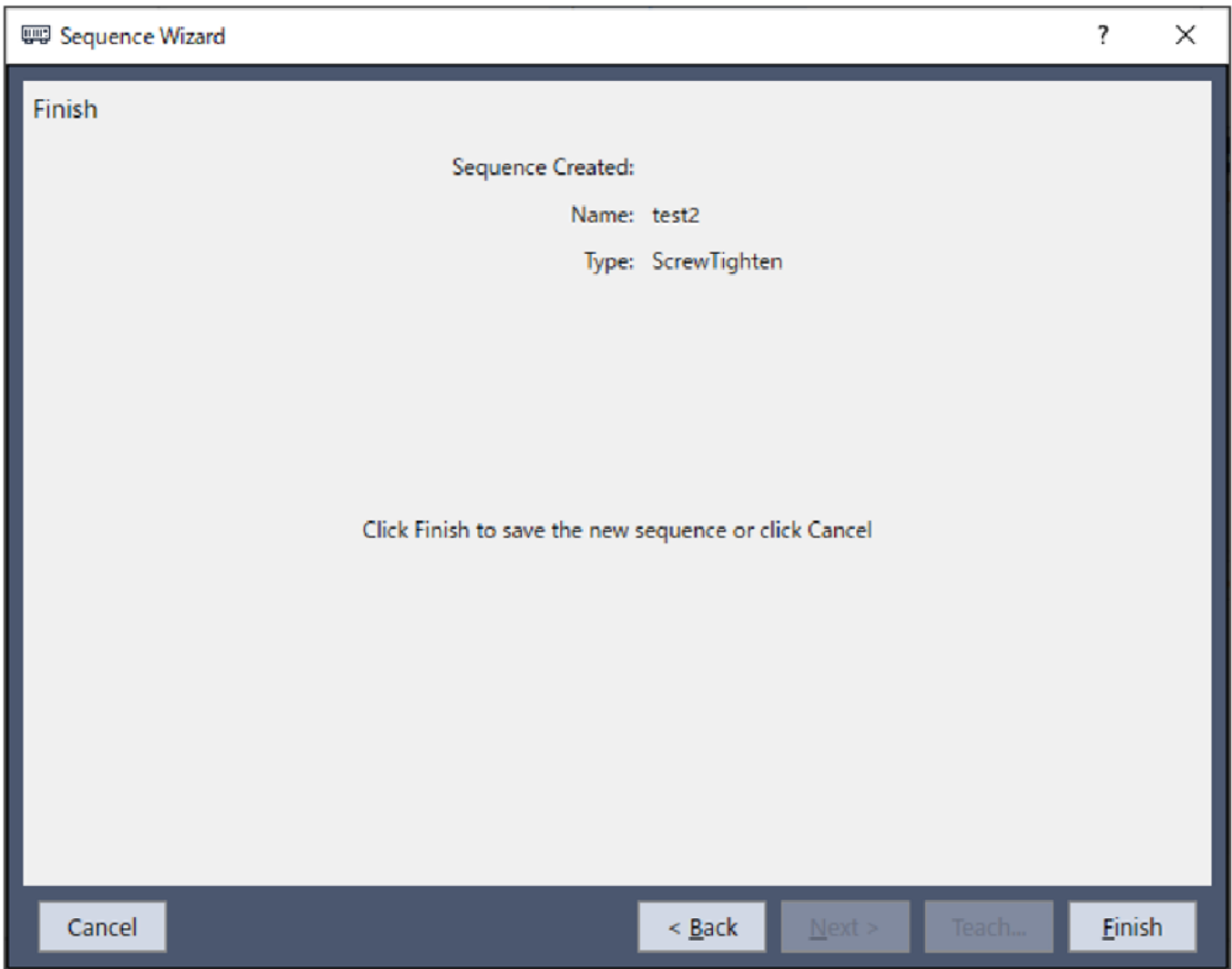

Item	Description
Name	The sequence name set in Step 1. General. Refer to the next section for setting the sequence name. Software [Force Guidance] [Tools] menu - Create a new force guide sequence - Sequence Wizard: Create a new system force guide sequence - Step1: General
Type	The sequence type set in Step 3. Select system sequence. Refer to the next section for selecting the sequence type. Software [Force Guidance] [Tools] menu Create a new force guide sequence - Sequence Wizard: Create a new system force guide sequence -Step 3: Select system sequence
[Cancel] button	Cancels a new ScrewTighten sequence creation. Click it to end a sequence wizard.
[Back] button	Returns to Step 8 when the screw retightening operation in Step 5 is disabled. Returns to Step 9 when the screw retightening operation in Step 5 is enabled.

Item	Description
[Next] button	You cannot click this button.
[Finish] button	Completes creating a new ScrewTighten sequence with the entered contents.

4.4.4.2 ScrewTighten Sequence

4.4.4.2.1 Property setting guidelines for ScrewTighten sequence

General setting steps and setting methods for each property are as follows:

Step 1. Set basic information

Set properties related to the basic information.

Properties	Description
Name	Force guide sequence name. Set a particular name.
Index	Particular number for a force guide sequence. It is assigned automatically. You cannot set this.
Description	Descriptions for force guide sequence. Describe the tasks. Set a character string.
Version	A compatible version of the sequence. The sequence operates with the specified version function.
RobotNumber	Robot number to execute a force guide sequence. Set a robot number to be executed.
RobotType	Robot type which is set by RobotNumber. You cannot set this.
AutoStepID	Set whether to set StepID of force guide object automatically. StepID is an ID which is recorded in the log data. It helps you to understand which log data support a process. True: Normal False: When you want to set StepID manually.
PointFile	Set a point file which will be used in a force guide sequence. An error occurs when the specified point file is not loaded at the start. This is a property for preventing a wrong operation. If a point file is not set, any point file whichever loads is executed.
RobotTool	Set a tool number which will be used in a force guide sequence. An error occurs when the set tool number is not selected at the start. This is a property for preventing a wrong operation.

Properties	Description
RobotHand	<p>This property sets the robot hand number to use during the force guide sequence execution.</p> <p>If the robot hand specified in this property is not set at the start of the force guide sequence, an error will occur.</p> <p>For details on the robot hand, refer to the following manual: "Hand Function Manual"</p>

Step 2. Set for correction of sensor value

Set properties (ResetSensor, MPNumber) related to sensor value correction.

Properties	Description, setting guide
ResetSensor	Set whether to reset the Force Sensor when executing a force guide object other than Decision object and SPELFunc object for the first time during the force guide sequence execution.
	True: When a workpiece has not been in contact with anything at the start of the force guide sequence. (Normally, it is in the non-contact state at the start of the force guide sequence.)
	False : Used in rare cases, such as when a force guide sequence is executed, and then another force guide sequence is executed with the contact state unchanged.
MPNumber	Specify the number of Mass Property Object which is used during the force guide sequence execution. Mass Property Object is a collection of properties using for gravity compensation.
	"0": When the orientations (U, V, W) do not change greatly during the force guide sequence execution.
	Created Mass Property number: When the orientations change greatly during the force guide sequence execution.
	For more details on Mass Property, refer to the following section. Software Gravity Compensation

Step 3. Set for driver operation

Set a property (DriverWaitTime) related to the driver operation.

Properties	Description
DriverWaitTime	<p>Set the time from when the driver to use gives the screw tightening completion signal to when it accepts the operation signal again.</p> <p>Set according to the feature of the driver to use.</p>

Step 4. Set for coordinate system of force control function

Set properties (ForceOrient, RobotLocal, RotationCenterType, RotationCenterTLX, RotationCenterTLY, RotationCenterTLZ) related to a coordinate system of the force control function.

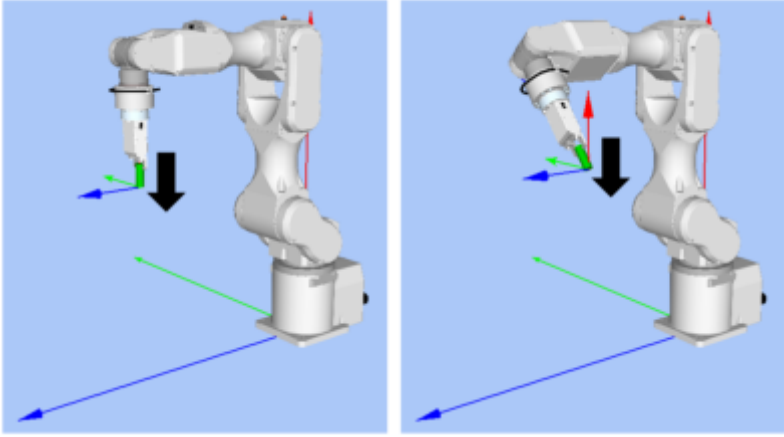
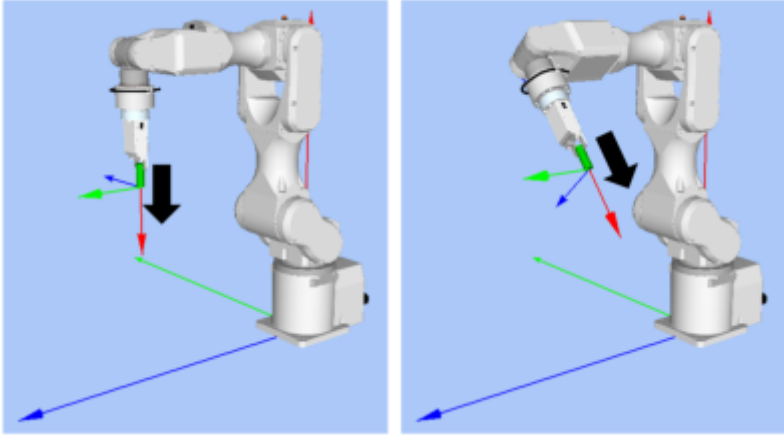
Properties	Description, setting guide
ForceOrient	<p>Set a coordinate system direction which executes the force control function.</p> <p>Base, Local: When you want to execute the force control function to a defined direction as viewed from outside, such as pressing to vertical-downward, even if the start orientation of force guide sequence is changed.</p> <p>Local is specified when a defined direction is different from the axis of the Base coordinate system. The following is an example to set Base.</p> <p>When pressing to -Z direction, the robot always presses to the vertical-downward (-Z direction in Base coordinate system) even the orientation of end effector changed. (Black arrow is a direction of the robot motion.)</p>  <p>Tool: When you want to execute the force control function depending on an orientation at the start. The following is an example to set Tool.</p> <p>When pressing to +Z direction, the pressing direction changes depending on the orientation of end effector at the start.</p> 
RobotLocal	Set Local coordinate system number which is used when ForceOrient is Local.
RotationCenterTLX RotationCenterTLY RotationCenterTLZ	Set an offset amount to each axis from Tool coordinate system to the rotation center.

You can check the settings related to the coordinate system of the force control function by using a simulator. However, if no force guide object is aligned in the force guide sequence, check the setting after adding the force guide objects. For details on how to check by using simulator, refer to the following manual.
 "Epson RC+ 8.0 User's Guide: - Simulator - Description of Functions"

Step 5. Set the maximum speed and the maximum acceleration

Set properties (LimitAccelS, LimitAccelR, LimitSpeedS, LimitSpeedR) related to the maximum speed and the maximum acceleration.

Properties	Description, setting guide
LimitSpeedS LimitSpeedR	<p>Set a maximum speed during the execution of the force guide sequence.</p> <p>LimitSpeedS: Maximum translational speed LimitSpeedR: Maximum rotational rotation speed</p> <p>In the force control function, the speed changes depending on the how the force is applied. It is controlled not to exceed LimitSpeedS and LimitSpeedR.</p>
LimitAccelS LimitAccelR	<p>Set a maximum acceleration during the execution of the force guide sequence.</p> <p>LimitAccelS: Maximum translational acceleration LimitAccelR: Maximum rotational rotation acceleration</p> <p>In the force control function, the acceleration changes depending on how the force is applied. It is controlled not to exceed LimitAccelS and LimitAccelR.</p> <p>If the value is small, reaction when the force is applied will be slow and the robot will bounce largely. Set a larger value when the robot bounces. When the robot vibrates, set the value smaller.</p>

Step 6. Set conditions about recording

Set properties (LogRobotLocal, LogFileEnabled, LogFileAutoName, LogFileNameVar, LogFileMaxTime, LogFileInterval) related to recording.

Properties	Description, setting guide
LogRobotLocal	Set a Local coordinate system number which will be a reference of the recording robot position. Log data related to positions is recorded as positions of the specified Local coordinate system.
	Base: Normal
	Local coordinate system number: When you want to record as a position in the specified Local coordinate system
LogFileEnabled	Set whether to save the log data which is executing a force guide sequence to a file.
	False: It is not saved in a file. You can check the log data on the graph of force guide window when executing.
LogFileAutoName	Set whether to set the log data file name automatically.
	True : When Automatically set Is generated by the force guide sequence name and the start time. "Force guide sequence name_yyyymmdd_hh:mm:ss:ms"
	False: When specifying a name
LogFileNameVar	Set a global variable which indicates a log data file name when LogFileAutoName is False.
LogFileInterval	Set a sampling interval of log data when creating files.
LogFileMaxTime	Set a maximum time of log data when creating files.

4.4.4.2.2 Details on properties of the ScrewTighten sequence

- Name Property
This property sets a particular name that is assigned to force guide sequences.
You cannot create the force guide sequence with the same name.

You can change the name. Set up 16 characters at the maximum. Please use alphanumeric characters and underscores [_].

Note: The initial character cannot be a numeric character.

- **Index Property**

This property displays a number of force guide sequence. This property is set and updated automatically. It cannot be edited.

	Value
Minimum Value	1
Maximum value	32

- **Description Property**

This property sets a description of force guide sequence.

You can set the character string up to 255 characters.

- **Version Property**

For system sequence, the version 7.5.1 supports. It cannot be changed.

- **RobotNumber Property**

This property sets a robot number that uses a force guide sequence.

An error occurs when executing the force guide sequence by the robot which is not specified.

Value	Description
1 to 16	Robot number to use a force guide sequence.

Default: Robot number specified in the sequence wizard.

- **RobotType Property**

This property is the robot types that use a force guide sequence.

It is automatically set from the robot number specified by RobotNumber. It cannot be edited.

- **AutoStepID Property**

This property sets an automatic assignment of StepID in force guide object execution.

When assigning a StepID automatically, it is set to the force guide sequence number*100 + the force guide object number. StepID is recorded to files that the force and the position during the force guide sequence execution is recorded. It is used to determine which interval corresponds to which force guide object.

Value	Description
True	Set StepID automatically.
False	Set a property value of StepID of each force guide object.

Default: True

- **ResetSensor Property**

This property sets whether to reset a Force Sensor when starting force guide object other than Decision object and SPELFunc object for the first time in the force guide sequence.

Value	Description
True	Reset the Force Sensor when starting a force guide object other than Decision object and SPELFunc object.
False	Force Sensor is not reset.

Default: True

- **MPNumber Property**

This property sets the number of Mass Property Object which is used during the force guide sequence execution.

Mass Property Object is a collection of properties using for gravity compensation. You need to define Mass Property Object in advance.

If an angle will change largely during the execution of the force guide sequence, make sure to specify the proper Mass Property Object.

Value	Description
0	Turn OFF the gravity compensation.
1 to 15	Use the specified Mass Property.

Default: 0

■ PointFile Property

This property sets the point file name that is used during the force guide sequence execution.

If the point file which is not specified by this property is loaded when the force guide sequence starts, an error occurs. This is a property for preventing a wrong operation.

Value	Description
None	Not specified (Any point file whichever loads can be executed without checking it.)
Point file name	An error occurs when the specified point file is not loaded.

Default: None

■ RobotTool Property

This property sets the Tool coordinate system number that is used during the force guide sequence execution.

If the Tool coordinate system number which is not specified by this property is selected when the force guide sequence starts, an error occurs. This is a property for preventing a wrong operation.

Value	Description
0 to 15	An error occurs when the set tool number is not selected.

Default: 0

■ RobotHand Property

This property sets the robot hand number to use during the force guide sequence execution.

If the robot hand specified in this property is not set at the start of the force guide sequence, an error will occur.

Value	Description
1 to 15	An error occurs when the robot hand is not set.

Default: 1

■ DriverWaitTime Property

Set the time from when the driver to use gives the screw tightening completion signal to when it accepts the operation signal again.

Set according to the feature of the driver to use.

	Value (unit: [sec])
Minimum Value	0
Maximum value	10

Default: 1

■ ForceOrient Property

This property specifies the direction of coordinate system that uses the force control functions during the force guide sequence execution.

You can select from Base, Local, and Tool. Specify the coordinate system that the direction to tighten screw.

If Base or Local is specified, the direction to tighten screw will not be changed even if the robot orientation changes.

If Tool is specified, the direction to tighten screw changes since the direction of Tool coordinate system changes when the robot orientation is changed.

Value	Description
Base	The direction of the coordinate system to which the force control function is applied is the Base coordinate system
Local	The direction of the coordinate system to which the force control function is applied is the Local coordinate system
Tool	The direction of the coordinate system to which the force control function is applied is the Tool coordinate system

Default: Tool

▪ RobotLocal Property

This property specifies the Local coordinate system number of coordinate system that applies the force control functions during the force guide sequence execution.

It is used when ForceOrient property is Local.

Value	Description
0 (Base)	Use the Local 0 coordinate system (Base coordinate system). It is the same as when specifying Base in ForceOrient.
1 to 15	Use the Local coordinate system of the specified number.

Default: 0 (Base)

▪ RotationCenterTLX Property

This property sets a distance in X direction from Tool coordinate system to the rotation center of the force control function. It is the X direction of the Tool coordinate system which is selected in RobotTool.

	Value (Unit: [mm])
Minimum Value	-2000
Maximum value	2000

Default: 0

▪ RotationCenterTLY Property

This property sets a distance in Y direction from Tool coordinate system to the rotation center of the force control function. It is the Y direction of the Tool coordinate system which is selected in RobotTool.

	Value (Unit: [mm])
Minimum Value	-2000
Maximum value	2000

Default: 0

▪ RotationCenterTLZ Property

This property sets a distance in Z direction from Tool coordinate system to the rotation center of the force control function. It is the Z direction of the Tool coordinate system which is selected in RobotTool.

	Value (Unit: [mm])
Minimum Value	-2000
Maximum value	2000

Default: 0

▪ **LimitSpeedS Property**

This property sets the maximum speed during the execution of force guide sequence.

The robot motion will change depending on applied force and torque when executing the force guide sequence since it is adjusted by the force control functions. However, it is restricted by the speed which is specified by this property.

	Value (unit: [mm/sec])
Minimum Value	0.1
Maximum value	250

Default: 50

▪ **LimitSpeedR Property**

This property sets the maximum rotation speed during the execution of force guide sequence.

The robot motion will change depending on applied force and torque when executing the force guide sequence since it is adjusted by the force control functions. However, it is restricted by the rotation speed which is specified by this property.

	Value (unit: [deg/sec])
Minimum Value	0.1
Maximum value	180

Default: 25

▪ **LimitAccelS Property**

This property sets the maximum acceleration during the execution of force guide sequence.

The robot motion will change depending on applied force and torque when executing the force guide sequence since it is adjusted by the force control functions. However, it is restricted by the acceleration which is specified by this property.

	Value (unit: [mm/sec ²])
Minimum Value	0.1
Maximum value	25000

Default: 200

▪ **LimitAccelR Property**

This property sets the maximum rotation acceleration during the execution of force guide sequence.

The robot motion will change depending on applied force and torque when executing the force guide sequence since it is adjusted by the force control functions. However, it is restricted by the rotation acceleration which is specified by this property.

	Value (unit: [deg/sec ²])
Minimum Value	0.1
Maximum value	5000

Default: 100

▪ **LogRobotLocal Property**

For the positional orientation of the robot that is recorded during the force guide sequence execution, set a reference local coordinate system number.

The position of the robot is recorded as that of Tool coordinate system as viewed from the Local coordinate system specified by this property.

Value	Description
0 (Base)	Use the Local 0 coordinate system (Base coordinate system).

Value	Description
1 to 15	Use the Local coordinate system of the specified number.

Default: 0 (Base)

■ LogFileEnabled Property

This property sets whether to save the force, torque, and the position of the robot during the force guide sequence execution in files.

When specifying True, value will be displayed in the graph on the monitor and saved in the files simultaneously.

When specifying False, value will be displayed in the graph on the monitor. However, the value is not saved in the files.

Value	Description
True	Save the log data in a file.
False	The log data is not saved in a file.

Default: False

■ LogFileAutoName Property

This property sets whether to automatically set the file name that records force, torque, and the position of the robot during the force guide sequence execution.

When specifying True, the file name is automatically set with the force guide sequence name + start time.

Force guide sequence name `__yyymmdd_hhmmssfff.csv`

When specifying False, add ".csv" to the string in variables which is specified in LogFileNameVar to make it a file name.

Value	Description
True	Set the name of the log data file automatically.
False	Set a log data file name to the one which is specified by LogFileNameVar.

Default: True

■ LogFileNameVar Property

This property sets a global string variable that saves a file name which records force, torque, and the position of the robot during the force guide sequence execution.

It is used when False is specified in LogFileAutoName. Add ".csv" to the string in variables and set it as a file name.

Value	Description
None	Not specified (automatically set)
Variable name	Value of the specified global string variable will be a file name. Only a string variable can be specified.

Default: None

■ LogFileInterval Property

This property sets the sampling period for the files that record force, torque, and the position of the robot during the force guide sequence execution.

	Value (unit: [sec])
Minimum Value	0.002
Maximum value	1

Default: 0.2

■ LogFileMaxTime Property

This property sets the maximum recording time for the files that record force, torque, and the position of the robot during the force guide sequence execution.

If the specified recording time is shorter than the execution time of the force guide sequence, nothing is recorded in the file after the recording time is passed. note that

	Value (unit: [sec])
Minimum Value	60
Maximum value	600

Default: 60

4.4.4.2.3 Details on results of ScrewTighten sequence

- EndStatus Result

It is a result of the execution.

Result will be succeeded when the force guide sequences are executed to the end and the final force guide object is succeeded or AbortSeqOnFail property of the final force guide object is False.

Value	Description
Passed	Force guide sequence is succeeded.
Failed	Force guide sequence is failed.
NoExec	Force guide sequence is not executed.
Aborted	Aborted during the execution of force guide sequence.

- FailedStatus Result

It is the reason why the force guide sequence failed.

It is the reason for failure when the result of executing an object with AbortSeqOnFail set to True.

Value	Description
OK	Force guide sequence is succeeded.
GeneralObjectFailed	General object is failed.
CollisionDetect	Failed due to the detection of collision.
Overrun	Failed due to overrun.
Jammed	The screw tightening completion signal was given by a driver, but failed due to the position is out of the success conditions.
NoOKSignal	Failed due to the screw tightening completion signal is not accepted.

- Time Result

This is the time required for execution.

Unit: [sec]

- LastExecObject Result

Force guide object name which is executed at the end.

- EndForces Result

Force and torque when force guide sequence ends. Acquire values of Fx, Fy, Fz, Tx, Ty, and Tz.

Unit: Fx, Fy, Fz [N] / Tx, Ty, Tz [N · mm]

- PeakForces Result

Peak values of force and torque during the force guide object execution. The peak value is a value which absolute value is

the largest. Acquire values of F_x , F_y , F_z , T_x , T_y , and T_z .

Unit: F_x , F_y , F_z [N] / T_x , T_y , T_z [N · mm]

4.4.4.3 ScrewTighten Object

The ScrewTighten object is a force guide object used to tighten screws while moving the robot by pressing in a specified direction with a specified amount of force.

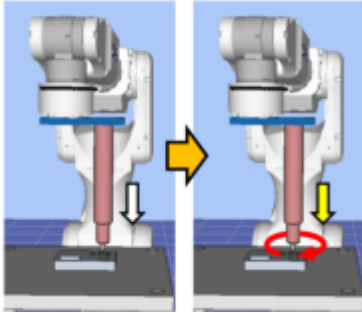

The diagram above provides a visual representation of a ScrewTighten object. Executed from a non-contact state, this object moves the robot in the screw tightening direction depicted by the white arrow. From the point of contact, the robot tightens screws with a set amount of force in the screw tightening direction shown by the yellow arrow.

The ScrewTighten object can apply end conditions related to the screw tightening completion signal given by driver, and force and position. Each end condition is always applied.

When all the success conditions for each end condition are met: The ScrewTighten object execution ends. The execution is determined as succeeded and proceed to the next force guide object. When the screw retightening operation is enabled, skip the ScrewRetighten object and proceed to the next object.

When at least one of the failure conditions for each end condition is met: The ScrewTighten object execution ends. The execution is determined as failed and abort the force guide sequence. When the screw retightening operation is enabled, when the screw tightening completion signal given by driver is received and the failure condition of the position end condition is satisfied, it is determined that the execution of the ScrewTighten object is finished and the screw is jammed, then proceed to the ScrewRetighten object.

End condition	Success condition
End conditions related to the screw tightening completion signal	The screw tightening completion signal given by driver is received.
End conditions related to position	The moving distance from the force guide object start point in the axial direction specified in PressOrient is within the range of ApproachDist + ScrewLength - DistCheckTol to ApproachDist + ScrewLength + DistCheckTol

End condition	Failure condition
End conditions related to the screw tightening completion signal	Moved from the force guide object start point by the amount specified by ApproachDist and InsertDepth, but did not receive the screw tightening completion signal from the driver.

End condition	Failure condition
End conditions related to position	Before receiving the screw tightening completion signal, the following is satisfied: Before receiving the screw tightening completion signal, the following is satisfied: The moving distance from the force guide object start point in the axial direction specified by PressOrient exceeds ApproachDist + InsertDepth + DistCheckTol. Alternatively, after receiving the screw tightening completion signal, the following is satisfied: The moving distance from the force guide object start point in the axial direction specified by PressOrient does not reach ApproachDist + InsertDepth - DistCheckTol.
End conditions related to force	The pressing force in the axial direction specified by PressOrient exceeds the value set by CollisionForceThresh.

4.4.4.3.1 Property guideline for ScrewTighten object

Step 1. Set basic information

Set properties (Name, Description, StepID, AbortSeqOnFail) related to the basic information.

Properties	Description, setting guide
Name	This property sets names of force guide objects. Set a particular name.
Description	This property sets descriptions about force guide objects. Describe the operations. Set a character string.
StepID	StepID during the force guide object execution. Set an ID. StepID is an ID which is recorded in the log data. It helps you to understand which log data support a process. It is applied when AutoStepID of the force guide sequence is False.
AbortSeqOnFail	Set whether to abort or continue the force guide sequence when the force guide object fails.
	True : Normal End a force guide sequence.
	False : Cases where the force guide sequence contains recovery operations in case of failure; cases where the sequence will be able to continue even in the event of a failure.

Step 2. Set a movement motion

Set properties (AccelS, SpeedS) related to movements.

Properties	Description, setting guide
AccelS	Set the translational acceleration of the movement. It is automatically set from the driver rotation speed and screw lead length set in the sequence wizard. When having trouble tightening the screws, you can change the value. Actual acceleration is adjusted by the force control functions.
SpeedS	Set the translational velocity of the movement. It is automatically set from the driver rotation speed and screw lead length set in the sequence wizard. When having trouble tightening the screws, you can change the value. Actual speed is adjusted by the force control functions.

Step 3. Set a destination point

Set properties (ApproachDist, ScrewLength) related to trajectories to move.

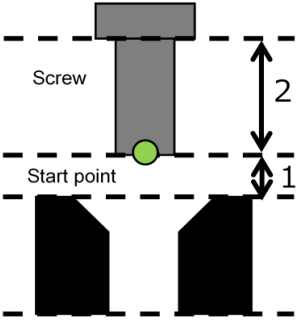
Properties	Description, setting guide
ApproachDist	<p>Set an approach distance from the start point of the force guide object to the opening of the screw hole. The approach distance is distance 1 depicted in the diagram below, which is the distance between the screw end point of the gripped workpiece at the start point of the force guide object indicated by the green dot, and the opening of screw hole.</p>  <p>Teach the robot a start point of the motion that shortens the approach distance as much as possible. As the force control function is slower than position control, longer approach distances will result in longer cycle times.</p>
ScrewLength	<p>Set the length of the screw. As shown in the ApproachDist diagram, ScrewLength is a length of 2.</p>

Step 4. Set force control functions

Set properties (PressOrient, PressForce, PressFirmnessF, FollowOrient, FollowFirmnessF) related to the force control functions.

Properties	Description, setting guide
PressOrient	<p>Set a direction to tighten screw. The robot moves to the specified direction.</p>
PressForce	<p>Set a pressing force to apply in the direction of screw tightening. When PressOrient is positive direction: Enter a negative value. When PressOrient is negative direction: Enter a positive value.</p>
PressFirmnessF	<p>Set a firmness of the force control functions in screw tightening direction.</p>
	<p>When setting a large value: The Force Control functions become stronger, but response to changes in force is slow.</p> <p>When setting a small value: The Force Control function will become weaker. Response to changes in force is fast; however, vibrations can easily occur.</p>
FollowOrient	<p>In addition to the PressOrient direction, it is the direction to move while following. It is changed automatically according to PressOrient. Read only. It cannot be edited.</p>
FollowFirmnesF	<p>Set a firmness of the force control functions in translational direction except for screw tightening direction.</p>
	<p>When setting a large value: The Force Control functions become stronger, but response to changes in force is slow.</p>

Properties	Description, setting guide
	When setting a small value: The Force Control function will become weaker. Response to changes in force is fast; however, vibrations can easily occur.

Step 5. Set end conditions related to force

Set properties (CollisionForceThresh) related to the end conditions of force.

Properties	Description, setting guide
CollisionForceThresh	This property sets a force to detect that a screw collides with a hole other than the screw hole during screw tightening operation. It fails when the pressing force exceeds the set value. The pressing force may be larger than the PressForce value due to the frictional force generated between the screw and the screw hole. Set it to a value sufficiently larger than the force set by PressForce.

Step 6. Set end conditions about position

Set property (DistCheckTol) related to the end conditions of the positions.

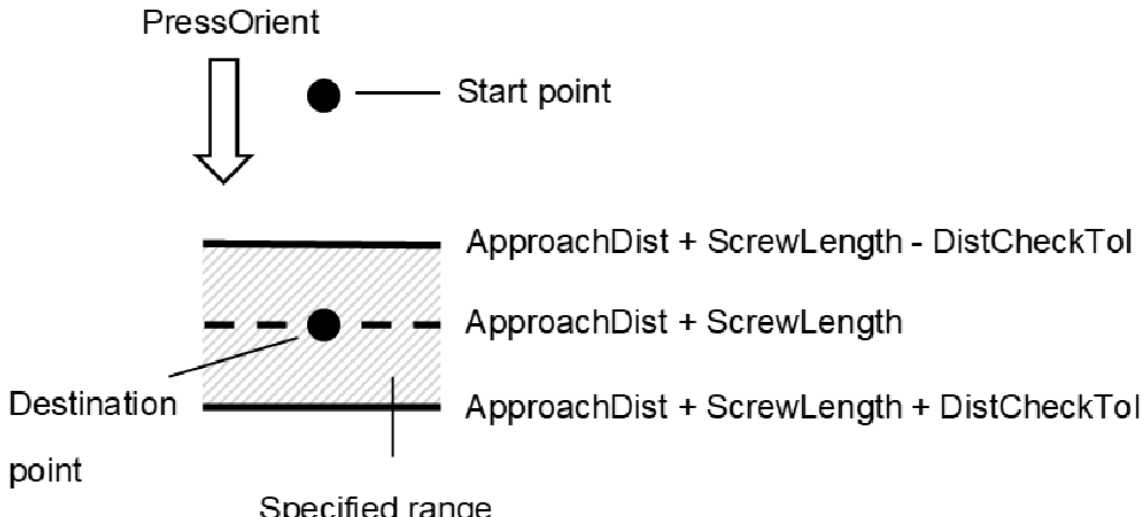
Properties	Description, setting guide
DistCheckTol	<p>This property sets the screw tightening direction range of the end conditions related to position. It monitors that the moving distance from the operation start point to the destination point in the direction specified by PressOrient is within the range of ApproachDist + ScrewLength - DistCheckTol to ApproachDist + ScrewLength + DistCheckTol</p> <p>The following is an image of DistCheckTol.</p> 

4.4.4.3.2 Details on the properties of the ScrewTighten object

- Name Property

This property sets a particular name that is assigned to force guide object.

When creating the ScrewTighten sequence, name is assigned automatically. Automatically assigned name is added a number after ScrewTighten (e.g. ScrewTighten01).

You can change the name. Set up 16 characters at the maximum. Please use alphanumeric characters and underscores [_].

Note: The initial character cannot be a numeric character.
- Description Property

This property sets descriptions about force guide objects. You can set the character string up to 255 characters.

▪ StepID Property

This property sets StepID during the execution of the force guide objects. It is only used when AutoStepID is False.

	Value
Minimum Value	0
Maximum value	32767

Default: Automatically set according to the numbers of the force guide sequence and the force guide object.

▪ AbortSeqOnFail Property

This property sets operations when force guide object fails.

When True is specified: If the force guide object fails, the program ends the force guide sequence and proceeds to the next SPEL statement.

When specifying False: If force guide object fails, the program proceeds to the next force guide object without ending the force guide sequence.

Use this property when you want to continue the force guide sequence (e.g. the recovery processes are included in the force guide sequence when the force guide object fails.)

Value	Description
True	Abort the force guide sequence when the force guide object fails.
False	Start the next force guide sequence when the force guide object fails.

Default: True

▪ SpeedS Property

This property sets speed of force guide objects during the execution.

When you create a ScrewTighten sequence, it is automatically set from the driver rotation speed and screw lead length set in the sequence wizard.

However, this set value is the speed for the set trajectory. The actual speed is adjusted by the force control functions.

	Value (unit: [mm/sec])
Minimum Value	0.1
Maximum value	200

Default: 5

▪ AccelS Property

This property sets acceleration of force guide objects.

When you create a ScrewTighten sequence, it is automatically set from the driver rotation speed and screw lead length set in the sequence wizard.

However, this set value is the acceleration for the set trajectory. The actual acceleration is adjusted by the force control functions.

	Value (unit: [mm/sec ²])
Minimum Value	1
Maximum value	2000

Default: 50

▪ ApproachDist Property

This property sets the moving distance from the start point of the force guide object to the start point of the insert operation.

Teach the robot a start point of the motion that shortens the moving distance as much as possible. As the force control function is slower than position control, longer moving distances will result in longer cycle times.

	Value (Unit: [mm])
Minimum Value	0
Maximum value	50

Default: 10

▪ ScrewLength Property

This property sets the screw length.

	Value (Unit: [mm])
Minimum Value	1
Maximum value	100

Default: 10

▪ PressOrient Property

This property sets the direction of motion for screw tightening operations in the coordinate system specified by the ForceOrient property for the force guide sequence.

Value	Description
+Fx	Sets the direction of motion to the +Fx direction in the specified coordinate system.
-Fx	Sets the direction of motion to the -Fx direction in the specified coordinate system.
+Fy	Sets the direction of motion to the +Fy direction in the specified coordinate system.
-Fy	Sets the direction of motion to the -Fy direction in the specified coordinate system.
+Fz	Sets the direction of motion to the +Fz direction in the specified coordinate system.
-Fz	Sets the direction of motion to the -Fz direction in the specified coordinate system.

Default: +Fz

▪ PressForce Property

This property sets the pressing force in the direction of motion specified by the PressOrient property for the force guide object during the execution of the force guide object.

- If PressOrient is +Fx, +Fy, +Fz:

	Value (unit: [N])
Minimum Value	-50
Maximum value	0

Default: -4

- If the PressOrient is -Fx, -Fy, or -Fz:

	Value (unit: [N])
Minimum Value	0
Maximum value	50

Default: 4

■ PressFirmnessF Property

This property sets the firmness in relation to the force control function in the direction of motion specified by the PressOrient property for the force guide object during the execution of the force guide object.

The larger the PressFirmnessF value, the stronger the force control function becomes in the direction of motion. This slows response to changes in force, but reduces vibration.

The smaller the PressFirmnessF value, the weaker the force control function becomes in the direction of motion. This speeds up response to changes in force, but increases vibration.

	Value
Minimum Value	0.1
Maximum value	10

Default: 2

■ FollowOrient Property

This property sets the translational following orientation set for screw tightening operations.

This property is set automatically based on the direction of motion set by the PressOrient property for the force guide object. It cannot be edited.

Value	Description
FyFz	Motion following in the FyFz direction.
FxFz	Motion following in the FxFz direction.
FxFy	Motion following in the FxFy direction.

Default: FxFy

■ FollowFirmnessF Property

This property sets the firmness in relation to the force control function for force in the following direction during the execution of the force guide object.

The larger the FollowFirmnessF value, the stronger the force control function becomes in the following direction. This slows response to changes in force, but reduces vibration.

The smaller the FollowFirmnessF value, the weaker the force control function becomes in the following direction. This speeds up response to changes in force, but increases vibration.

	Value
Minimum Value	0.1
Maximum value	10

Default: 1

■ CollisionForceThresh Property

This property sets a force to detect that a screw collides with a hole other than the screw hole during screw tightening operation.

Set it to a value sufficiently larger than the force set by PressForce.

- If PressOrient is +Fx, +Fy, +Fz:

	Value (unit: [N])
Minimum Value	-100
Maximum value	-10

Default: -30

- If the PressOrient is -Fx, -Fy, or -Fz:

	Value (unit: [N])
Minimum Value	10
Maximum value	100

Default: 30

- DistCheckTol Property

Specify the range that is the success condition (when the operation is finished) of the distance moved from the operation start position.

This sets the ApproachDist + ScrewLength ± DistCheckTol range as the success condition.

	Value
Minimum Value	0.01
Maximum value	10

Default: 1

4.4.4.3.3 Details on results of ScrewTighten object

- EndStatus Result

It is a result of the execution.

It succeeds when the "success conditions" described in 4.2.2.2 Relax Object are satisfied.

ScrewTighten Object

Value	Description
Passed	Force guide object is succeeded.
Failed	Force guide object is failed.
NoExec	Force guide object is not executed.
Aborted	Aborted during the execution of force guide object.
FailedCont	Force guide object is failed, but the next force guide object is executed.

- Time Result

This is the time required for execution.

Unit: [sec]

- EndForces Result

It is force and torque when force guide object ends. Acquire values of Fx, Fy, Fz, Tx, Ty, and Tz.

Unit: Fx, Fy, Fz [N] / Tx, Ty, Tz [N · mm]

- EndPos Result

Positions when the force guide object ends. Acquire values of X, Y, Z, U, V, and W.

Unit: X, Y, Z [mm] / U, V, W [deg]

- AvgForces Result

Average values of force and torque during the force guide object execution. Acquire values of Fx, Fy, Fz, Tx, Ty, and Tz.

Unit: Fx, Fy, Fz [N] / Tx, Ty, Tz [N · mm]

- PeakForces Result

Peak values of force and torque during the force guide object execution. The peak value is a value which absolute value is

the largest. Acquire values of Fx, Fy, Fz, Tx, Ty, and Tz.

Unit: Fx, Fy, Fz [N] / Tx, Ty, Tz [N · mm]

▪ TriggeredForces Result

It is the force and torque when satisfying the end conditions related to force. Acquire values of Fx, Fy, Fz, Tx, Ty, and Tz.

Unit: Fx, Fy, Fz [N] / Tx, Ty, Tz [N · mm]

▪ TriggeredPos Result

Positions when satisfying the end conditions related to force. Acquire values of X, Y, Z, U, V, and W.

Unit: X, Y, Z [mm] / U, V, W [deg]

▪ PosCondOK Result

Shows whether the end conditions related to position were satisfied.

Value	Description
True	Satisfy the end conditions related to position.
False	The end conditions related to position are not satisfied.

▪ IOCondOK Result

Shows whether the end conditions related to I/O were satisfied.

Value	Description
True	Satisfy the end conditions related to I/O.
False	The end conditions related to I/O are not satisfied.

▪ PosLimited Result

Shows whether the limit range related to position was exceeded.

Value	Description
True	Exceed the limit range related to position.
False	The limit range related to position is not exceeded.

▪ ForceLimited Result

Shows whether the limiting range related to force was exceeded.

Value	Description
True	Exceed the limit range related to force.
False	The limit range related to force is not exceeded.

4.4.4.4 ScrewRetighten Object

The ScrewTighten object is a force guide object used to loosen screws once, while moving the robot by pressing in a specified direction with a specified amount of force, then retighten screws.

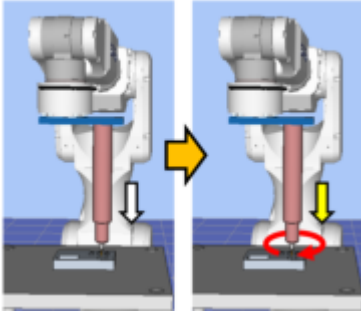

The diagram above provides a visual representation of a ScrewTighten object. After executing the ScrewTighten object, if the screw is not tightened properly, the robot loosens the screw with pressing force in the screw tightening direction shown by the yellow arrow and retighten.

The ScrewRetighten object can apply end conditions related to the screw tightening completion signal given by driver, and force and position. Each end condition is always applied.

When all the success conditions for each end condition are met: The ScrewRetighten object execution ends. The execution is determined as succeeded and proceed to the next force guide object.

When at least one of the failure conditions for each end condition is met: The ScrewRetighten object execution ends. The execution is determined as failed and abort the force guide sequence.

End condition	Success condition
End conditions related to the screw tightening completion signal	The screw tightening completion signal given by driver is received.
End conditions related to position	The moving distance from the force guide object start point in the axial direction specified in PressOrient is within the range of ApproachDist + ScrewLength - DistCheckTol to ApproachDist + ScrewLength + DistCheckTol

End condition	Failure condition
End conditions related to the screw tightening completion signal	The screw tightening completion signal given by driver is not received.
End conditions related to position	Before receiving the screw tightening completion signal, the following is satisfied: The moving distance from the force guide object start point in the axial direction specified by PressOrient exceeds ApproachDist + InsertDepth + DistCheckTol. Alternatively, after receiving the screw tightening completion signal, the following is satisfied: The moving distance from the force guide object start point in the axial direction specified by PressOrient does not reach ApproachDist + InsertDepth - DistCheckTol.

4.4.4.4.1 Property guidelines for the ScrewRetighten object

Step 1. Set basic information

Set properties (Name, Description, StepID, AbortSeqOnFail) related to the basic information.

Properties	Description, setting guide
Name	This property sets names of force guide objects. Set a particular name.
Description	This property sets descriptions about force guide objects. Describe the operations. Set a character string.
Enabled	Set whether to execute the force guide object.
	True : Normal
	False : When you do not execute the force guide object (e.g., when you execute another force guide object instead).
StepID	StepID during the force guide object execution. Set an ID. StepID is an ID which is recorded in the log data. It helps you to understand which log data support a process. It is applied when AutoStepID of the force guide sequence is False.
AbortSeqOnFail	Set whether to abort or continue the force guide sequence when the force guide object fails.
	True : Normal End a force guide sequence.
	False : Cases where the force guide sequence contains recovery operations in case of failure; cases where the sequence will be able to continue even in the event of a failure.

Step 2. Set force control functions

Set properties (AddRetightenPressForce, RetightenPressForce) related to the pressing direction and force control functions.

Properties	Description, setting guide
AddRetightenPressForce	This property sets a pressing force to apply to retighten a screw. It is the force to apply to PressForce of the ScrewTighten object to prevent the screw from coming out of the driver bit during the screw tightening operation. Normally set to 0. If the screw comes out during the screw retightening operation, add the force gradually.
RetightenPressForce	This property displays the pressing force to retighten the screw. It is the value obtained by adding AddRetightenPressForce to PressForce of the screw tightening object. Read only. It cannot be edited.

Step 3. Set driver operation

Set properties (LoosenTime) related to driver operation.

Properties	Description, setting guide
LoosenTime	This property sets a time for loosening screw. If the driver screw loosening completion bit is not set in the robot hand settings, rotate the driver in the loosening direction for the set time. If the screwdriver loosening completion bit is set in the robot hand settings, rotate the driver in the loosening direction until the screw loosening completion signal is received or the set time elapses.

4.4.4.4.2 Details on the properties of the ScrewRetighten object

- Name Property
This property sets a particular name that is assigned to force guide object.

When creating the screw retighten sequence, name is assigned automatically. Automatically assigned name is added a number after ScrewRetighten (e.g. ScrewRetighten01).

You can change the name. Set up 16 characters at the maximum. Please use alphanumeric characters and underscores [_].

Note: The initial character cannot be a numeric character.

■ Description Property

This property sets descriptions about force guide objects.

You can set the character string up to 255 characters.

■ StepID Property

This property sets StepID during the execution of the force guide objects. It is only used when AutoStepID is False.

	Value
Minimum Value	0
Maximum value	32767

Default: Automatically set according to the numbers of the force guide sequence and the force guide object.

■ AbortSeqOnFail Property

This property sets operations when force guide object fails.

When True is specified: If the force guide object fails, the program ends the force guide sequence and proceeds to the next SPEL statement.

When specifying False: If force guide object fails, the program proceeds to the next force guide object without ending the force guide sequence.

Use this property when you want to continue the force guide sequence (e.g. the recovery processes are included in the force guide sequence when the force guide object fails.)

Value	Description
True	Abort the force guide sequence when the force guide object fails.
False	Start the next force guide sequence when the force guide object fails.

Default: True

■ LoosenTime Property

This property sets a time for loosening screw.

If the screw loosening complete bit is configured for the screwdriver in robot hand settings, screw loosening will stop if the screw loosening complete signal is received before the loosen timeout elapses. Screw loosening will stop regardless of whether a screw loosening complete signal is received when the loosen timeout runs out.

	Value (unit: [sec])
Minimum Value	0.1
Maximum value	1

Default: 0.1

■ AddRetightenPressForce Property

This property sets a pressing force to apply to retighten a screw.

It is the force to apply to PressForce of the ScrewTighten object to prevent the screw from coming out of the driver bit during the screw tightening operation. Normally set to 0.

If the screw comes out during the screw retightening operation, add the force gradually.

- If PressOrient of the ScrewTighten object is +Fx, +Fy, and +Fz:

	Value (unit: [N])
Minimum Value	-10

	Value (unit: [N])
Maximum value	0

Default: 0

- If PressOrient of the ScrewTighten object is -Fx, -Fy, and -Fz:

	Value (unit: [N])
Minimum Value	0
Maximum value	10

Default: 0

- RetightenPressForce Property

This property displays the pressing force to retighten the screw.

It is the value obtained by adding AddRetightenPressForce to PressForce of the screw tightening object. Read only. It cannot be edited.

4.4.4.4.3 Details on the results of the ScrewRetighten object

- EndStatus Result

It is a result of the execution.

It succeeds when the "success conditions" described in 4.2.2.2 Relax Object are satisfied.

ScrewRetighten Object

Value	Description
Passed	Force guide object is succeeded.
Failed	Force guide object is failed.
NoExec	Force guide object is not executed.
Aborted	Aborted during the execution of force guide object.

- Time Result

This is the time required for execution.

Unit: [sec]

- EndForces Result

It is force and torque when force guide object ends. Acquire values of Fx, Fy, Fz, Tx, Ty, and Tz.

Unit: Fx, Fy, Fz [N] / Tx, Ty, Tz [N · mm]

EndPos Result

Positions when the force guide object ends. Acquire values of X, Y, Z, U, V, and W.

Unit: X, Y, Z [mm] / U, V, W [deg]

- AvgForces Result

Average values of force and torque during the force guide object execution. Acquire values of Fx, Fy, Fz, Tx, Ty, and Tz.

Unit: Fx, Fy, Fz [N] / Tx, Ty, Tz [N · mm]

- PeakForces Result

Peak values of force and torque during the force guide object execution. The peak value is a value which absolute value is the largest. Acquire values of Fx, Fy, Fz, Tx, Ty, and Tz.

Unit: Fx, Fy, Fz [N] / Tx, Ty, Tz [N · mm]

▪ PosCondOK Result

Shows whether the end conditions related to position were satisfied.

Value	Description
True	Satisfy the end conditions related to position.
False	The end conditions related to position are not satisfied.

▪ IOCondOK Result

Shows whether the end conditions related to I/O were satisfied.

Value	Description
True	Satisfy the end conditions related to I/O.
False	The end conditions related to I/O are not satisfied.

4.4.4.5 Adjustment Guideline for ScrewTighten Sequence and Object Property Values

The following section describes how to adjust when using ScrewTighten sequence and objects.

- If GeneralObjectFailed appears as the FailedStatus result:
A failure has occurred with a general object placed in the ScrewTighten sequence. The last executed object appears in the LastExecObject result. Adjust the property of the object that appears here by referring to the property setting guideline or adjustment guideline for the property.
- If CollisionDetect appears as the FailedStatus result:
A failure has occurred because the force met the force failure condition set by the object during sequence execution.
- If the ScrewTighten object appears as the LastExecObject result:
The screw may have been tightened in a position where it is not in the screw hole. Check the operation start point and teach again.
If the teaching is correct, increase the CollisionForceThresh value. If the CollisionForceThresh is small, it may be falsely detected as a collision due to the force applied during screw tightening.
- If the ScrewRetighten object appears as the LastExecObject result:
Increase the CollisionForceThresh value. If the CollisionForceThresh is small, it may be falsely detected as a collision due to the force applied during screw retightening.
- If Overrun appears as the FailedStatus result:
Even though the position exceeded the position success condition range set by the object during the ScrewTighten object or ScrewRetighten object execution, a position overrun was detected and a failure has occurred because the motion executed without receiving the screw tightening completion signal.
Check that the ApproachDist and ScrewLength values are not too small compared to the actual operating environment.
- If Jammed appears as the FailedStatus result:
A jamming failure has occurred because the position did not meet the position success condition at the point when the screw tightening completion signal is received during the ScrewTighten object or ScrewRetighten object execution. The screw may be at too much of a tilt toward the screw hole. Check the orientation of the screw at the start point of the motion, and redo the teaching process.
If the teaching is correct, check that the ApproachDist and ScrewLength values are not too large compared to the actual operating environment.

- NoOKSignal appears as the FailedStatus result:
If the screw tightening completion signal cannot be received during execution of the sequence, it is determined that the completion signal has not been received and it has failed.
Make sure that the screw tightening completion bit is set correctly in the robot hand settings.
- If the driver bit comes out from screw hole during screw retightening:
Increase the AddRetightenPressForce value. However, the pressing force during screw tightening will increase, adjust it to an appropriate value.
- When the robot motion vibrates:
Increase the Firmness value. However, response of the robot will be slow. Please perform proper adjustments for your operations.
To adjust the Firmness, we recommend changing the value gradually (e.g. increase the value by 10% from its present state).
- When the robot bounces largely in the pressing direction:
If the robot repeatedly bounces largely in a few seconds, the robot motion may be restricted by LimitAccelS of the force guide sequence.
Also, it likely to happen during the execution in low power mode.
If the robot still bounces even executing in high power mode, increase the value of LimitAccelS. If the robot still bounces, decrease the value of Firmness in pressing direction.
- When the robot does not reach to the target force:
Decrease the Firmness value of the pressing direction.
However, the robot motion may be easy to vibrate. Please perform proper adjustments for your operations.
To adjust the Firmness, we recommend changing the value gradually (e.g. decrease the value by 10% from its current state).
- When the robot does not move to the pressing direction:
Confirm that the ControlMode where the robot does not move is either Press+ or Press-.
When Press+ or Press- is set, confirm whether the PressForce is set to "0".
- When the robot moves in the reverse direction:
Confirm that the ControlMode where the robot moves in the reverse direction is either Press+ or Press-.
When the robot is set to assumed direction, confirm the ForceOrient or RobotLocal of the force guide sequence, tool coordinate system, or local coordinate system.
- When the robot does not reach to the destination point:
If the direction where the force control functions are not enabled is not reached to the destination point, it may be affected by the LimitAccel or LimitSpeed of the force guide sequence. Increase the value.
Also, in low power mode, it is restricted according to the maximum speed or maximum acceleration of the low power mode even the value of LimitSpeed or LimitAccel is large. Be sure to execute in high power mode.

4.4.5 HeightInspect Sequence and Object

The HeightInspect sequence is a function that moves the robot in a specified direction and inspects the contact position with a specified force. It is used for dimensional inspection of workpiece and confirmation of success or failure of assembly.

A HeightInspect sequence is composed of a HeightInspect object. General force guide objects can also be added depending on the work procedure.

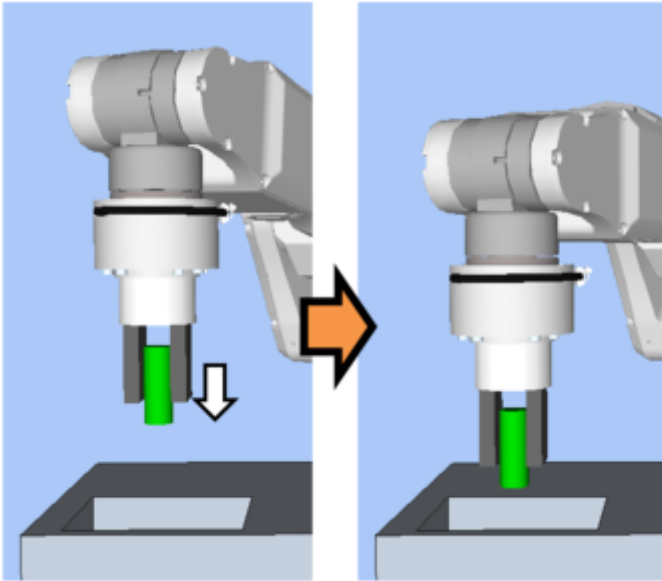

The diagram above provides a visual representation of a HeightInspect sequence. Executed from a non-contact state, this sequence moves the robot in the pressing direction depicted by the white arrow. The motion procedure up to this point is executed by a HeightInspect object.

This chapter covers the sequence wizards and properties of force guide HeightInspect sequence and HeightInspect objects. For more information about general force guide objects, see the next section.

Software [General force guide object](#)

Key Point

The function provided by the HeightInspect sequence is not a function that guarantees absolute accuracy like an inspection machine. Accuracy is affected by the position and orientation of the robot performing the operation, a hand and a workpiece, and the gantry on which the robot is installed. Check the repeatability accuracy from the result of executing the sequence multiple times for a normal workpiece, and then apply it to the actual operation.

4.4.5.1 Sequence Wizard for a HeightInspect Sequence

Use the sequence wizard to create a HeightInspect sequence. This sequence wizard can be displayed by doing the following.

- Right click the sequence flow in the flowchart, or the sequence node in the sequence tree, and then select [Sequence Wizard].
- Click the  button shown to the right of the [Click to open->] Wizard setting in the HeightInspect sequence property.

When the sequence wizard appears, configure settings as instructed on the screen.

The sequence wizard for a HeightInspect sequence can also be configured on the new sequence screen for creating a new force guide sequence. For more information, see the following section.

Software [Force Guidance] [\[Tools\] menu](#)

- Create a new force guide sequence - Sequence Wizard, Create a new system force guide sequence

Step 1. Select the robot tool to use for the end effector

Select the tool number to be used for the HeightInspect sequence and HeightInspect object.

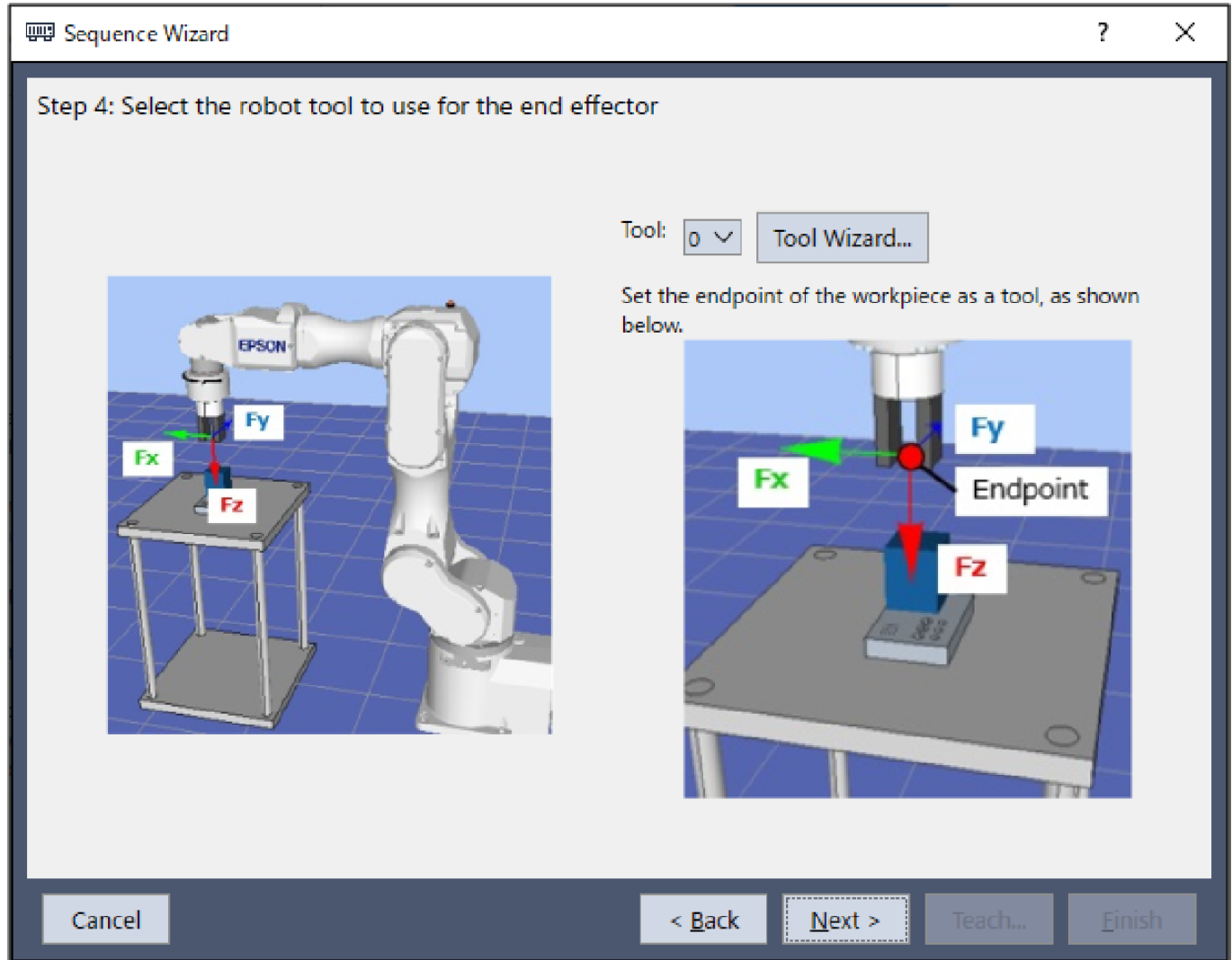

Item	Description, settings guide
Tool	Select the tool number to be used. Select a tool number so that the end point of the workpiece is at the tool origin point. Tool numbers set are sorted in the list. To set a new tool, use the Tool Wizard button. "Epson RC+ 8.0 User's Guide - Epson RC+ 8.0 GUI - [Tools] menu, [Tools] - [Robot Manager] - [Tool Settings] panel" Minimum value: 0 Maximum value: Maximum value for the set tool number Default: 0
[Cancel] button	Cancels a new HeightInspect sequence creation. Click it to end a sequence wizard.
[Back] button	When opening from the new sequence creation screen, you can return to the previous Step.
[Next] button	Proceeds to the next Step.
[Finish] button	You cannot click this button.

Step 2. Set tool offsets

When the tool set in Step 1 is not set in the center of the workpiece tip, this setting is required. Set the offset amount from the tool to the center of the workpiece tip.

Sequence Wizard
?
×

Step 5: Set tool offsets

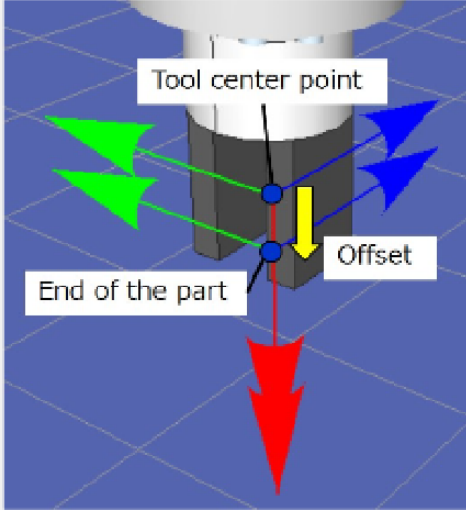

Use the offsets if the tool is not the endpoint of the part.

Set the offsets from X and Y center of the robot tool to the X and Y center of the part. In addition, set the Z offset from the end of the robot tool to the end of the part.

X Offset: mm

Y Offset: mm

Z Offset: mm

Cancel
< Back
Next >
Teach...
Finish

Item	Description, setting guide
X Offset	Sets the offset amount in the X direction from the tool set in Step 1 to the tip of the workpiece. Minimum value: -2000.000 [mm] Maximum value: 2000.000 [mm] Default: 0.000[mm]
Y Offset	Sets the offset amount in the Y direction from the tool set in Step 1 to the tip of the workpiece. Minimum value: -2000.000 [mm] Maximum value: 2000.000 [mm] Default: 0.000[mm]
Z Offset	Sets the offset amount in the Z direction from the tool set in Step 1 to the tip of the workpiece. Minimum value: -2000.000 [mm] Maximum value: 2000.000 [mm] Default: 0.000[mm]
[Cancel] button	Cancels a new HeightInspect sequence creation. Click it to end a sequence wizard.
[Back] button	Returns to the previous Step.

Item	Description, setting guide
[Next] button	Proceeds to the next Step.
[Finish] button	You cannot click this button.

Step 3. Set height inspection method and direction

Set the height inspection method.

Select "Tool" to measure the distance from the position when starting the sequence to the contact point of workpiece.

Select "Base or Local" to measure the position on the specified robot coordinate system when contacting workpiece.

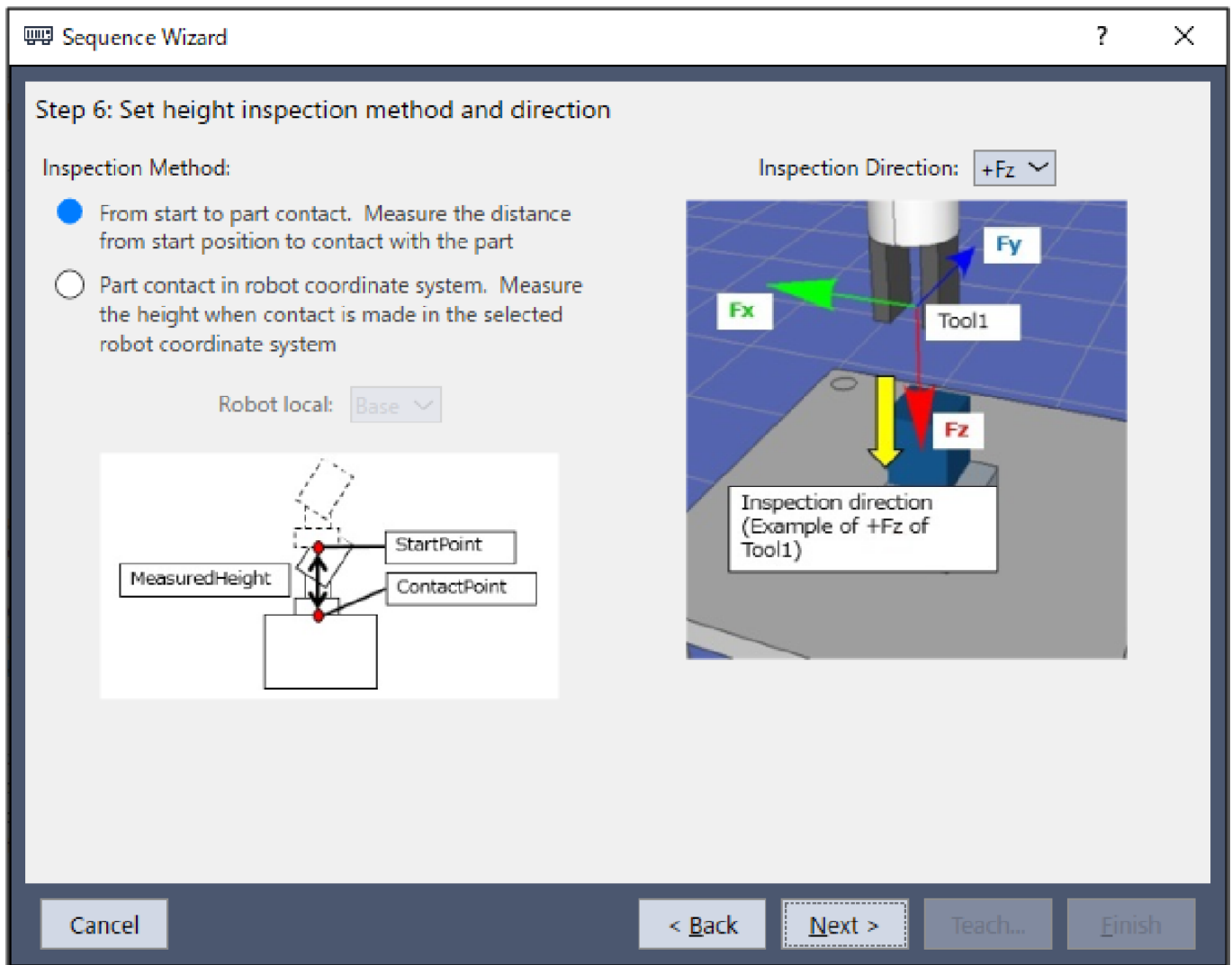

Item	Description, setting guide
Robot local	<p>Select the coordinate system used by the HeightInspect sequence.</p> <p>When the height inspection method is set to "Base" or "Local", the robot will move in the corresponding coordinate system. Select the coordinate system according to the orientation of the workpiece being inserted.</p> <p>Minimum value: Base (0)</p> <p>Maximum value: 15</p> <p>Default: Base</p>
Inspection direction	<p>Select the direction of the inspection.</p> <p>When the inspection method is set to "Tool", the HeightInspect sequence and HeightInspect object will move in the direction of the inspection selected for the tool coordinate system set in Step 1.</p> <p>When the height inspection method is set to "Base" or "Local", the HeightInspect sequence and HeightInspect object will move in the direction of the inspection selected for the base or local coordinate system set as the coordinate system.</p> <p>Values: +Fx, -Fx, +Fy, -Fy, +Fz, -Fz</p> <p>Default: +Fz</p>
[Cancel] button	<p>Cancels a new HeightInspect sequence creation.</p> <p>Click it to end a sequence wizard.</p>
[Back] button	<p>Returns to the previous Step.</p>
[Next] button	<p>Proceeds to the next Step.</p>
[Finish] button	<p>You cannot click this button.</p>

Step 4. Configure the reference distance/position and tolerance

When the tool coordinate system is selected in Step 3, configure the reference distance and tolerance of the height inspection.

Sequence Wizard
?
×

Step 7: Configure the reference distance and tolerance

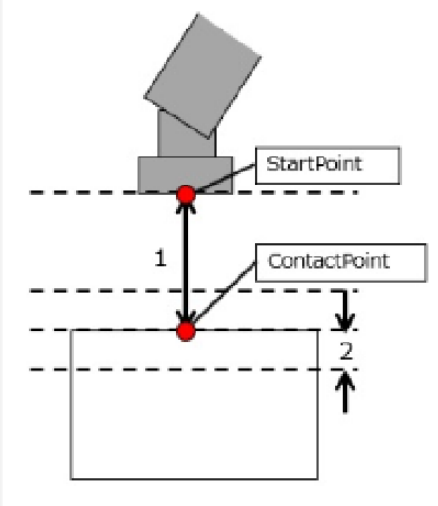

1. Reference distance: mm

2. Tolerance: mm

Cancel
< Back
Next >
Teach...
Finish

Item	Description, setting guide
Reference distance	<p>Set a reference distance.</p> <p>This is the moving distance in the direction set in the height inspect direction of the coordinate system set in the inspection method in Step 3.</p> <p>The reference distance is distance 1 (in the figure below) between the operation start point indicated by the upper red dot in the figure below and the planned contact point indicated by the lower red dot.</p> <p>Teach the robot a start point of the motion that shortens the inspection reference distance as much as possible.</p> <p>As the force control function is slower than position control, longer inspection reference distances will result in longer cycle times.</p>

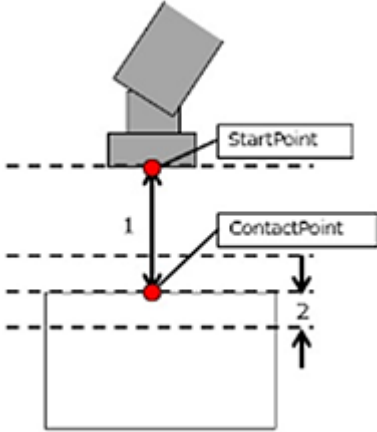
Item	Description, setting guide
	 <p>Minimum value: 0 [mm] Maximum value: 50 [mm] Default: 10[mm]</p>
Effective Range	<p>Set a tolerance. The tolerance is the length of 2 in the inspection success condition range in the figure in Reference distance. The lower this tolerance value, the stricter success conditions are for the operation. It is recommended that you increase the tolerance, and then adjust it back based on actual operation results obtained.</p> <p>Minimum value: 0.01 [mm] Maximum value: 10 [mm] Default: 1[mm]</p>
[Cancel] button	<p>Cancels a new HeightInspect sequence creation. Click it to end a sequence wizard.</p>
[Back] button	<p>Returns to the previous Step.</p>
[Next] button	<p>Proceeds to the next Step.</p>
[Finish] button	<p>You cannot click this button.</p>

When the "Base or Local" coordinate system is selected in Step 3, set the reference position and tolerance for height inspection.

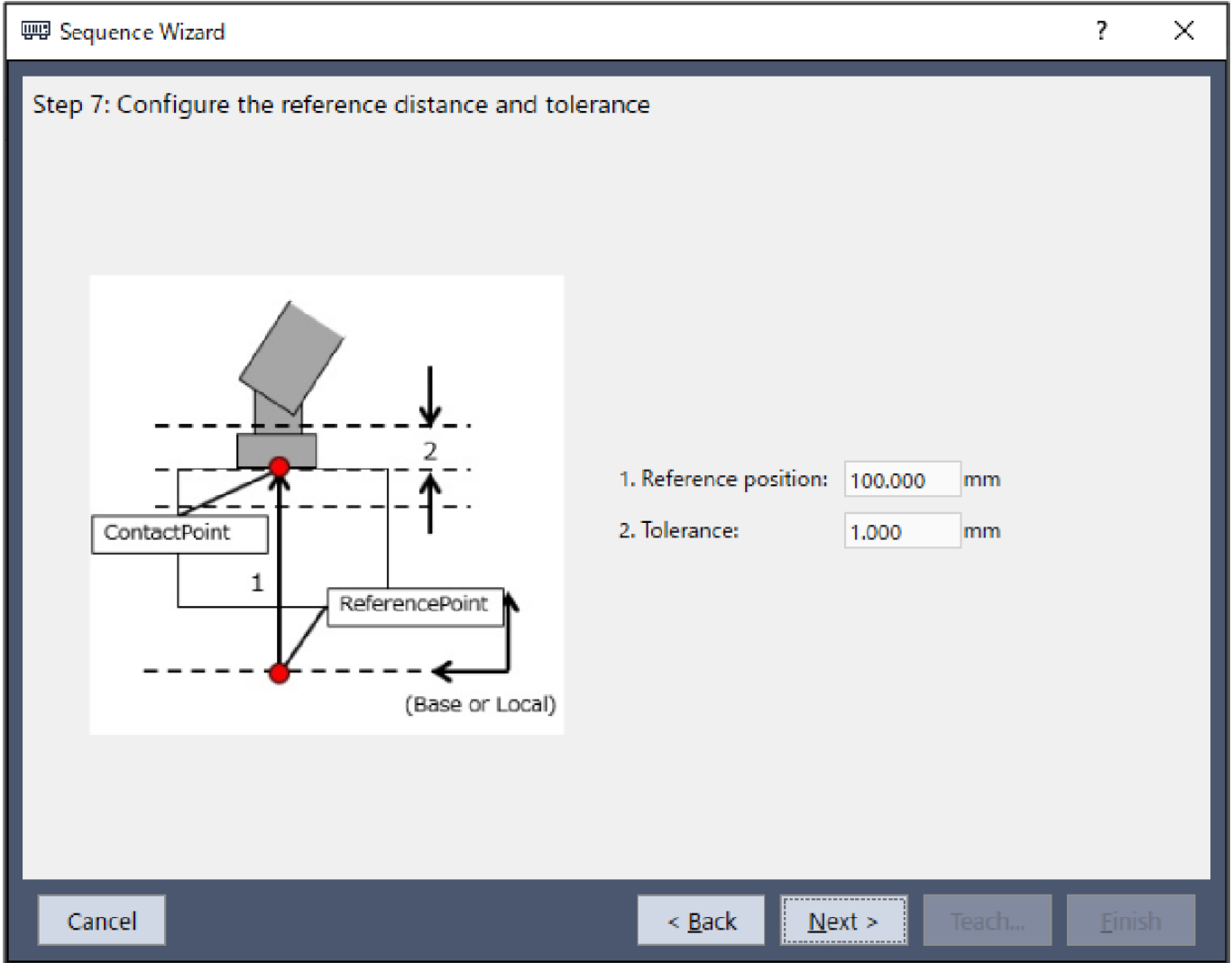

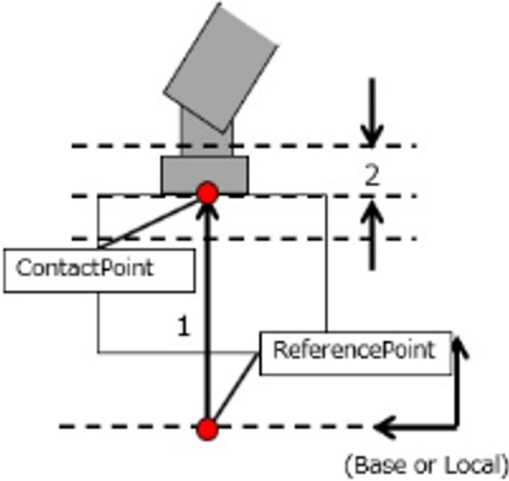

Item	Description, setting guide
Reference position	<p>Set a reference position. This is the position in the direction set in the height inspecting direction of the coordinate system set in the inspection method in Step 3.</p> <p>The reference position is the position to be contacted, which is indicated by the upper red dot in the figure below.</p> <p>Teach the robot a start point of the motion that shortens the distance from the start point to the contact point as much as possible. As the force control function is slower than position control, longer motion distances will result in longer cycle times.</p>

Item	Description, setting guide
	 <p>Minimum value: -2000 [mm] Maximum value: 2000 [mm] Default: 100[mm]</p>
Effective Range	<p>Set a tolerance. The tolerance is the length of 2 in the inspection success condition range in the figure in Reference position. The lower this tolerance value, the stricter success conditions are for the operation. It is recommended that you increase the tolerance, and then adjust it back based on actual operation results obtained.</p> <p>Minimum value: 0.01 [mm] Maximum value: 10 [mm] Default: 1[mm]</p>
[Cancel] button	<p>Cancels a new HeightInspect sequence creation. Click it to end a sequence wizard.</p>
[Back] button	<p>Returns to the previous Step.</p>
[Next] button	<p>Proceeds to the next Step.</p>
[Finish] button	<p>You cannot click this button.</p>

Step 5. Set height inspect speed

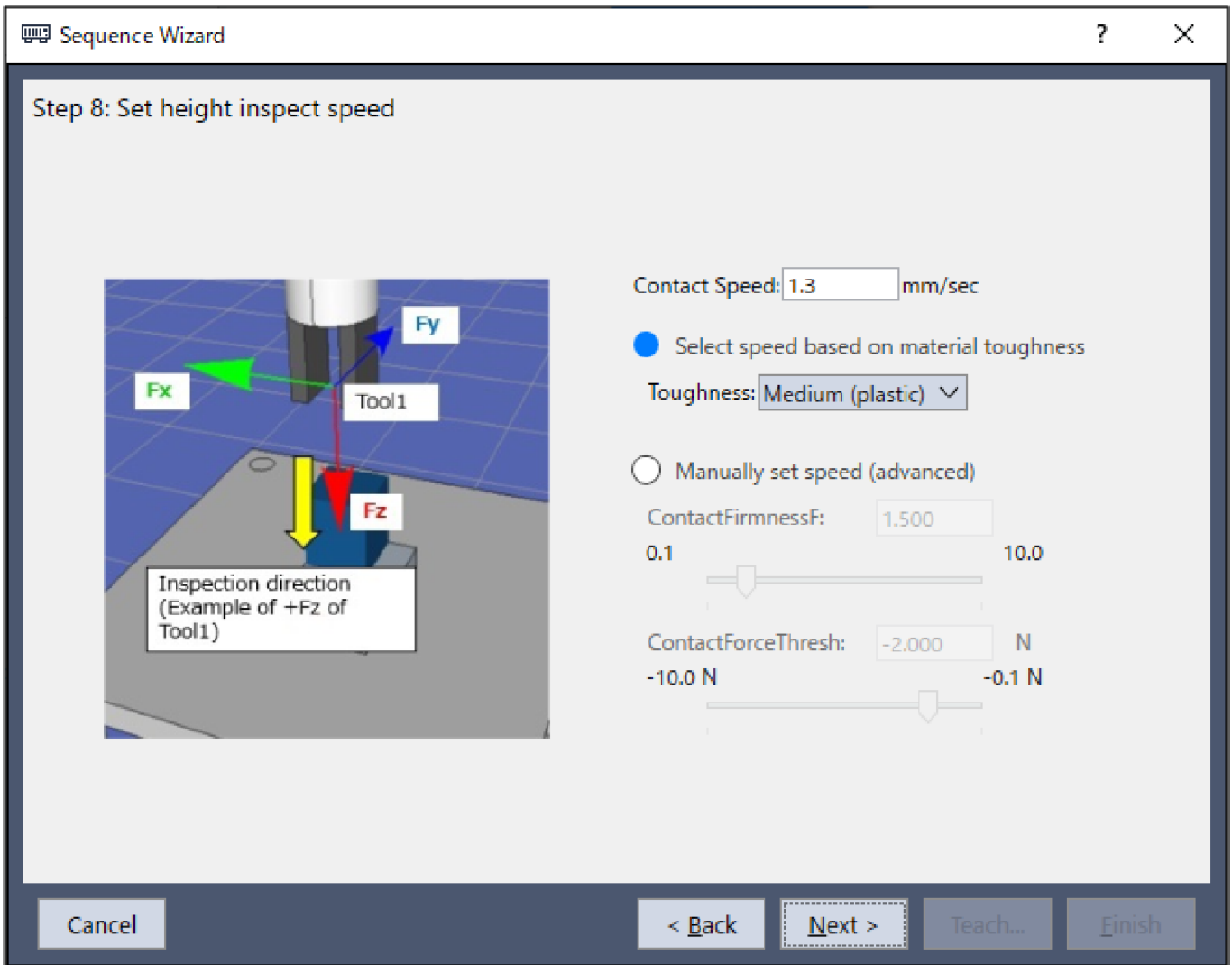
Set the contact speed of the height inspection from the preset. While this property setting can be configured directly, this is for advanced users.



Item	Description, setting guide
Toughness	Select the toughness of the workpiece material. Choose from three presets, "Fragile", "Normal", and "Hard". A guideline for the different levels of toughness to choose from is provided below. Fragile: Glass Normal: Plastic Hard: Metal When "Fragile" is selected for toughness, the contact speed will be slow. When "Hard" is selected, the contact speed will be increased. This can be set by selecting "Select speed based on material toughness".
ContactFirmnessF	Set a toughness of the force control function. When you set a large value: It becomes tough and slows down the contact speed. When you set a small value: It becomes soft and increases the contact speed, but may be vibrating. This can be set by selecting "Manually set speed (advanced)". Press the  button to adjust the toughness using a slider. Minimum value: 0.1 [mm] Maximum value: 10 [mm] Default: 1.5[mm]

Item	Description, setting guide
ContactForceThresh	Set a threshold to determine that the target is contacted. This can be set by selecting "Manually set speed (advanced)". Press the  button to adjust the force threshold using a slider.
	When the contact direction is in the positive direction: Minimum value: -10 [N] Maximum value: -0.1 [N] Default: -2 [N]
	When the contact direction is in the negative direction: Minimum value: 0.1 [N] Maximum value: 10 [N] Default: 2 [N]
[Cancel] button	Cancels a new HeightInspect sequence creation. Click it to end a sequence wizard.
[Back] button	Returns to the previous Step.
[Next] button	Proceeds to the next Step.
[Finish] button	You cannot click this button.

Step 6. Set the timeout for the operation

Set the time-out for the operation.

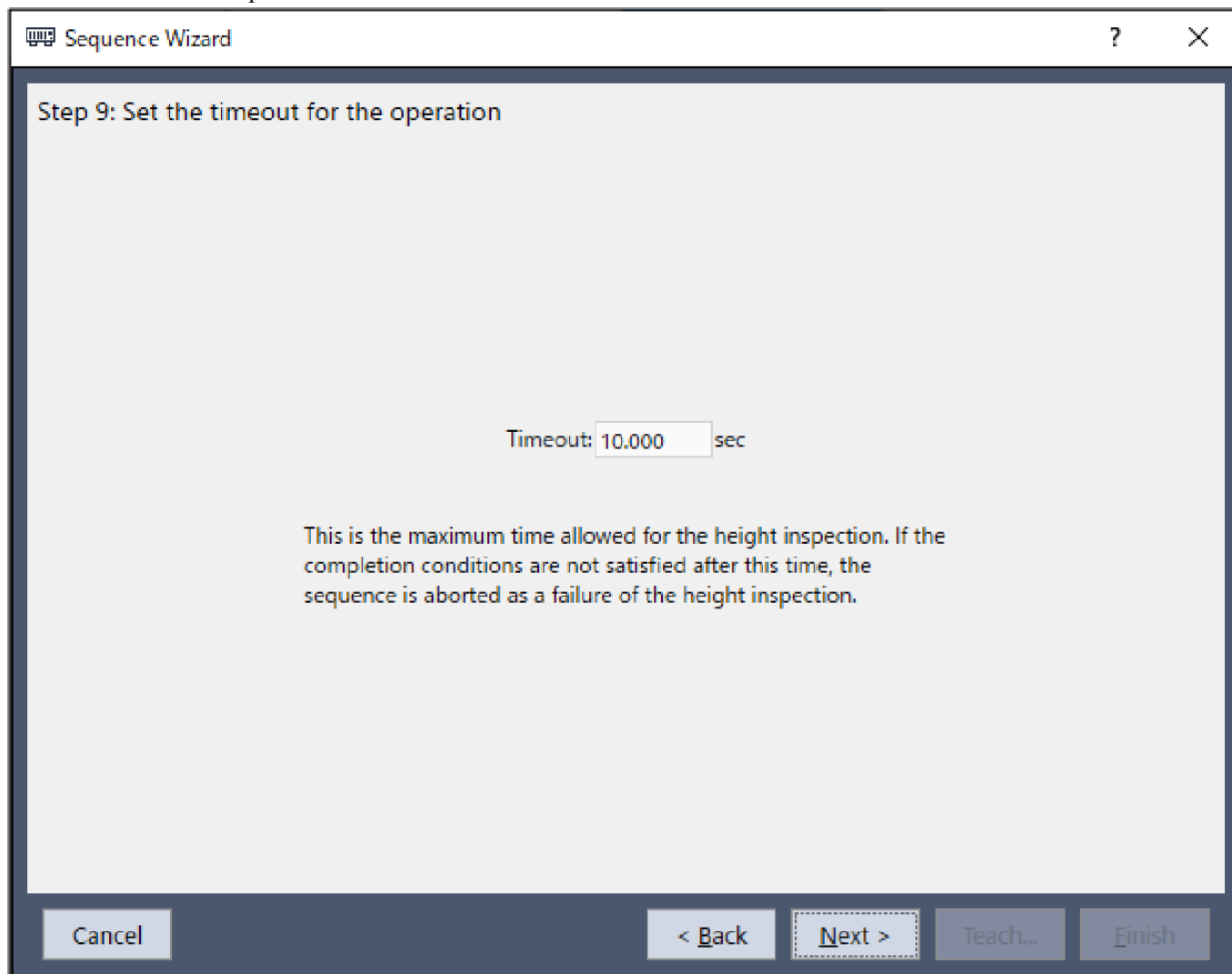

Item	Description, setting guide
Timeout	Set the time-out duration. The time-out set is the height inspect operation execution time. If the height inspect operation fails to complete even when the timeout elapses, the height inspect operation will be aborted in failure. Minimum value: 0.1 [sec] Maximum value: 60 [sec] Default: 10.0 [sec]
[Cancel] button	Cancels a new HeightInspect sequence creation. Click it to end a sequence wizard.
[Back] button	Returns to the previous Step.
[Next] button	You can proceed to the Change Summary screen. When you open from the new sequence creation screen, you can proceed to the Finish screen.
[Finish] button	You cannot click this button.

Step 7. Change Summary

You can see the list of properties that have been changed in the wizard.

This is displayed when you edit the created HeightInspect sequence in the Sequence Wizard. It is not displayed when creating a new one.

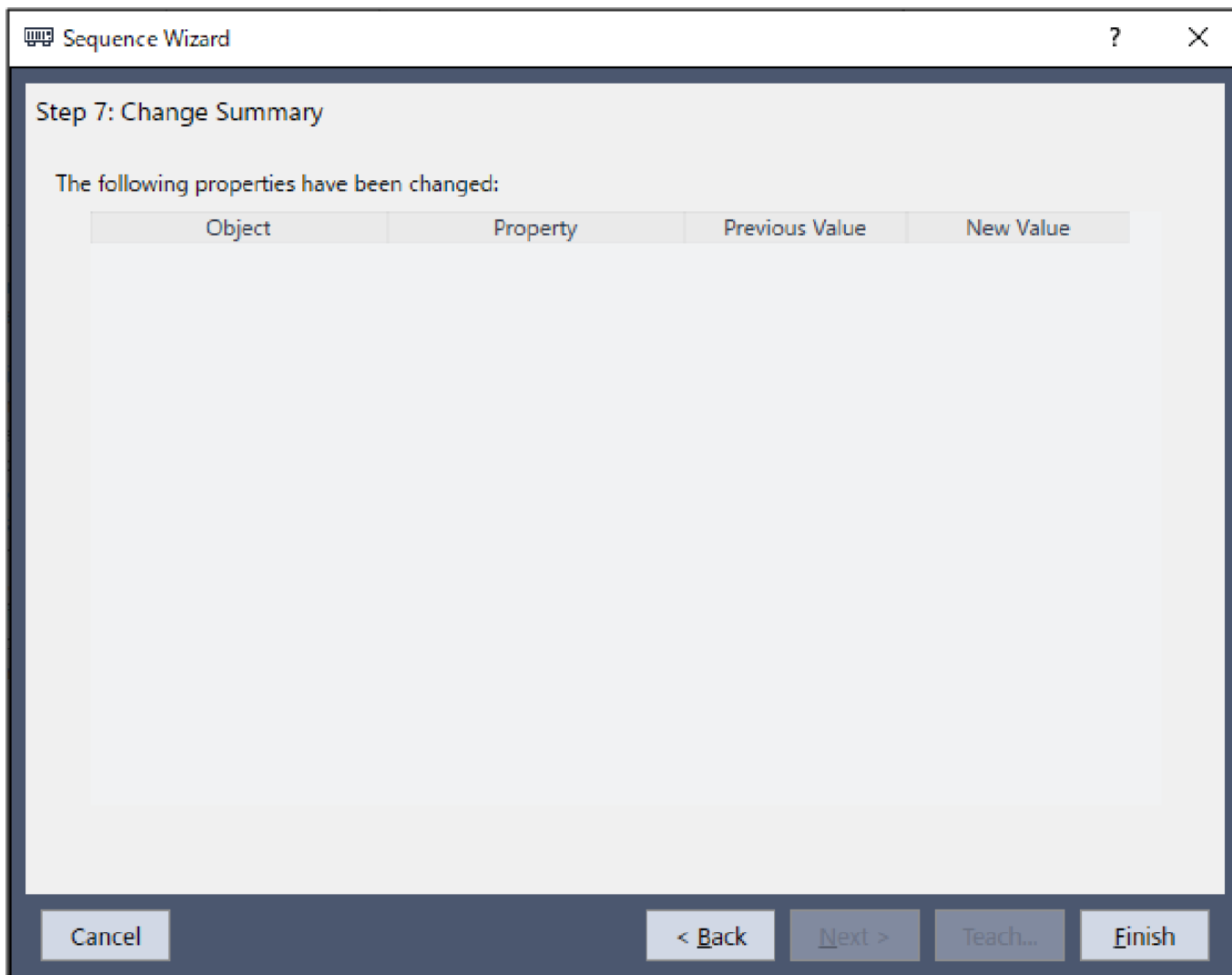

Item	Description
Object Property	Shows which properties of which sequence or object have been changed as a result of changing settings in the wizard.
Previous Value New Value	Shows how the properties have been changed as a result of changing the settings in the wizard.
[Cancel] button	Cancels a new HeightInspect sequence creation. Click it to end a sequence wizard.
[Back] button	Returns to Step 6.
[Next] button	You cannot click this button.
[Finish] button	Completes changing the HeightInspect sequence with the entered contents.

Finish: Height Inspect Sequence Created

This is the completion screen for the set sequence. You can check the created sequence name and type. The screen is displayed when opening from the new sequence creation screen.

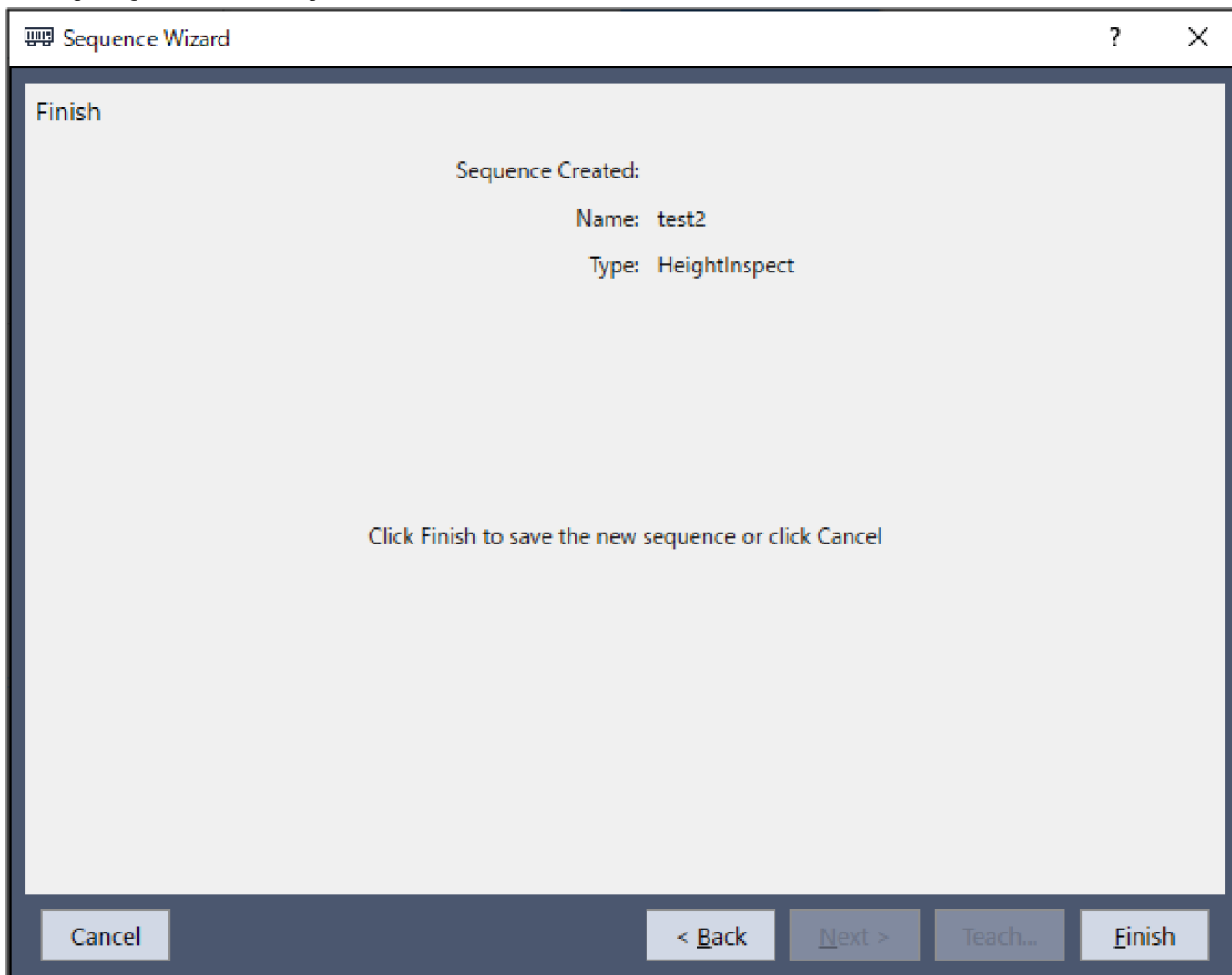

Item	Description
Name	The sequence name set in Step 1. General. Refer to the next section for setting the sequence name. Software [Force Guidance] [Tools] menu - Create a new force guide sequence - Sequence Wizard: Create a new system force guide sequence - Step1: General
Type	The sequence type set in Step 3. Select system sequence. Refer to the next section for selecting the sequence type. Software [Force Guidance] [Tools] menu Create a new force guide sequence - Sequence Wizard: Create a new system force guide sequence -Step 3: Select system sequence
[Cancel] button	Cancels a new HeightInspect sequence creation. Click it to end a sequence wizard.
[Back] button	Returns to Step 6.
[Next] button	You cannot click this button.

Item	Description
[Finish] button	Completes creating a new HeightInspect sequence with the entered contents.

4.4.5.2 HeightInspect Sequence

The following describes properties of the HeightInspect sequence and its setting steps.

4.4.5.2.1 Property setting guidelines for HeightInspect sequence

General setting steps and setting methods for each property are as follows:

Step 1. Set basic information

Set properties related to the basic information.

Properties	Description
Name	Force guide sequence name. Set a particular name.
Index	Particular number for a force guide sequence. It is assigned automatically. You cannot set this.
Description	Descriptions for force guide sequence. Describe the tasks. Set a character string.
Version	A compatible version of the sequence. The sequence operates with the specified version function.
RobotNumber	Robot number to execute a force guide sequence. Set a robot number to be executed.
RobotType	Robot type which is set by RobotNumber. You cannot set this.
AutoStepID	Set whether to set StepID of force guide object automatically. StepID is an ID which is recorded in the log data. It helps you to understand which log data support a process. True: Normal False: When you want to set StepID manually.
PointFile	Set a point file which will be used in a force guide sequence. An error occurs when the specified point file is not loaded at the start. This is a property for preventing a wrong operation. If a point file is not set, any point file whichever loads is executed.
RobotTool	Set a tool number which will be used in a force guide sequence. An error occurs when the set tool number is not selected at the start. This is a property for preventing a wrong operation.

Step 2. Set for correction of sensor value

Set properties (ResetSensor, MPNumber) related to sensor value correction.

Properties	Description, setting guide
ResetSensor	Set whether to reset the Force Sensor when executing a force guide object other than Decision object and SPELFunc object for the first time during the force guide sequence execution.
	True: When a workpiece has not been in contact with anything at the start of the force guide sequence. (Normally, it is in the non-contact state at the start of the force guide sequence.)
	False : Used in rare cases, such as when a force guide sequence is executed, and then another force guide sequence is executed with the contact state unchanged.
MPNumber	Specify the number of Mass Property Object which is used during the force guide sequence execution. Mass Property Object is a collection of properties using for gravity compensation.
	"0": When the orientations (U, V, W) do not change greatly during the force guide sequence execution.
	Created Mass Property number: When the orientations change greatly during the force guide sequence execution.
	For more details on Mass Property, refer to the following section. Software Gravity Compensation

Step 3. Set for coordinate system of force control function

Set properties (InspectMethod, ForceOrient, RobotLocal, RotationCenterType, RotationCenterTLX, RotationCenterTLY, RotationCenterTLZ) related to a coordinate system of the force control function.

Properties	Description, setting guide
InspectMethod	Set a height inspect method of parts. Set DistInspect to inspect by the moving distance. Set PosInspect to inspect by the position.
ForceOrient	Set a coordinate system direction which executes the force control function. If DistInspect is set in InspectMethod, the Tool coordinate system is applied. If PosInspect is set in InspectMethod, select Base or Local.
	Base, Local: When you want to execute the force control function to a defined direction as viewed from outside, such as pressing to vertical-downward, even if the start orientation of force guide sequence is changed. Local is specified when a defined direction is different from the axis of the Base coordinate system. The following is an example to set Base. When pressing to -Z direction, the robot always presses to the vertical-downward (-Z direction in Base coordinate system) even the orientation of end effector changed. (Black arrow is a direction of the robot motion.)

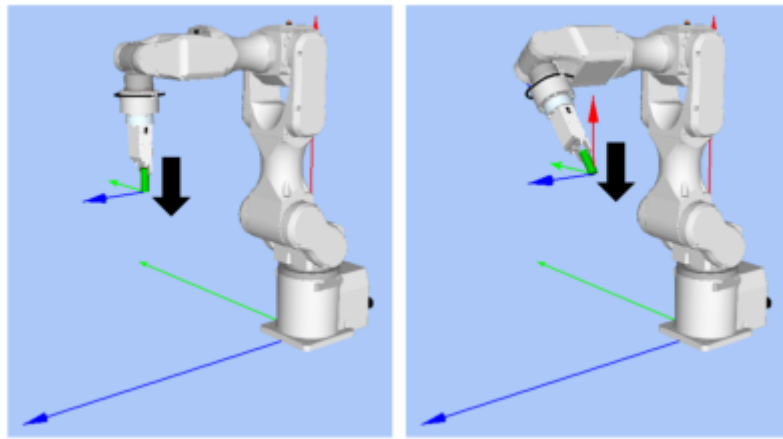

Tool:

When you want to execute the force control function depending on an orientation at the start. The following is an example to set Tool.

When pressing to +Z direction, the pressing direction changes depending on the orientation of end effector at the start.

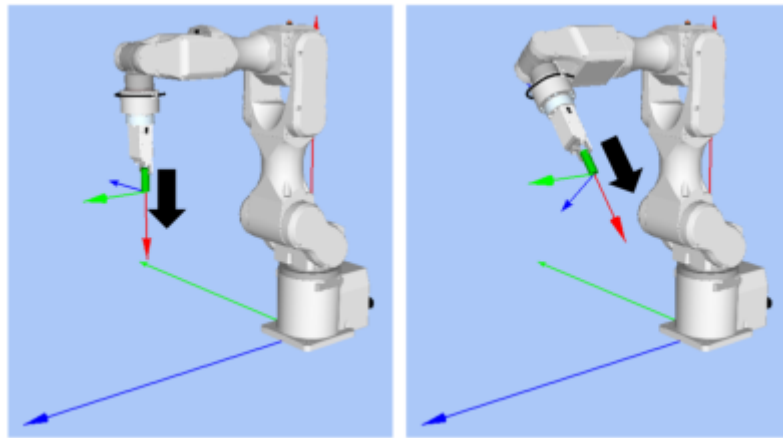

RobotLocal	Set Local coordinate system number which is used when ForceOrient is Local.
RotationCenterTLX RotationCenterTLY RotationCenterTLZ	Set an offset amount to each axis from Tool coordinate system to the rotation center.

You can check the settings related to the coordinate system of the force control function by using a simulator. However, if no force guide object is aligned in the force guide sequence, check the setting after adding the force guide objects.

For details on how to check by using simulator, refer to the following manual.

"Epson RC+ 8.0 User's Guide: - Simulator - Description of Functions"

Step 4. Set the maximum speed and the maximum acceleration

Set properties (LimitAccelS, LimitAccelR, LimitSpeedS, LimitSpeedR) related to the maximum speed and the maximum acceleration.

Properties	Description, setting guide
LimitSpeedS LimitSpeedR	Set a maximum speed during the execution of the force guide sequence. LimitSpeedS: Maximum translational speed LimitSpeedR: Maximum rotational rotation speed In the force control function, the speed changes depending on the how the force is applied. It is controlled not to exceed LimitSpeedS and LimitSpeedR.

LimitAccelS LimitAccelR	Set a maximum acceleration during the execution of the force guide sequence. LimitAccelS: Maximum translational acceleration LimitAccelR: Maximum rotational rotation acceleration In the force control function, the acceleration changes depending on how the force is applied. It is controlled not to exceed LimitAccelS and LimitAccelR. If the value is small, reaction when the force is applied will be slow and the robot will bounce largely. Set a larger value when the robot bounces. When the robot vibrates, set the value smaller.
----------------------------	---

Step 5. Set conditions about recording

Set properties (LogRobotLocal, LogFileEnabled, LogFileAutoName, LogFileNameVar, LogFileMaxTime, LogFileInterval) related to recording.

Properties	Description, setting guide
LogRobotLocal	Set a Local coordinate system number which will be a reference of the recording robot position. Log data related to positions is recorded as positions of the specified Local coordinate system.
	Base: Normal
	Local coordinate system number: When you want to record as a position in the specified Local coordinate system
LogFileEnabled	Set whether to save the log data which is executing a force guide sequence to a file.
	False: It is not saved in a file. You can check the log data on the graph of force guide window when executing.
LogFileAutoName	Set whether to set the log data file name automatically.
	True : When Automatically set Is generated by the force guide sequence name and the start time. "Force guide sequence name_yyyymmdd_hh:mm:ss:ms"
	False: When specifying a name
LogFileNameVar	Set a global variable which indicates a log data file name when LogFileAutoName is False.
LogFileInterval	Set a sampling interval of log data when creating files.
LogFileMaxTime	Set a maximum time of log data when creating files.

4.4.5.2.2 Details on properties of HeightInspect sequence

- **Name Property**
 This property sets a particular name that is assigned to force guide sequences. You cannot create the force guide sequence with the same name.
 You can change the name. Set up 16 characters at the maximum. Please use alphanumeric characters and underscores [_].
 Note: The initial character cannot be a numeric character.
- **Index Property**
 This property displays a number of force guide sequence. This property is set and updated automatically. It cannot be edited.

	Value
Minimum Value	1
Maximum value	32

- **Description Property**
This property sets a description of force guide sequence. You can set the character string up to 255 characters.
- **Version Property**
For system sequence, the version 7.5.1 supports. It cannot be changed.
- **RobotNumber Property**
This property sets a robot number that uses a force guide sequence. An error occurs when executing the force guide sequence with a robot which is not specified.

Value	Description
1 to 16	Robot number to use a force guide sequence.

Default: Robot number specified in the sequence wizard.

- **RobotType Property**
This property is the robot types that use a force guide sequence.
It is automatically set from the robot number specified by RobotNumber. It cannot be edited.
- **AutoStepID Property**
This property sets an automatic assignment of StepID in force guide object execution.
When assigning a StepID automatically, it is set to the force guide sequence number*100 + the force guide object number. StepID is recorded to files that the force and the position during the force guide sequence execution is recorded. It is used to determine which interval corresponds to which force guide object.

Value	Description
True	Set StepID automatically.
False	Set a property value of StepID of each force guide object.

Default: True

- **ResetSensor Property**
This property sets whether to reset a Force Sensor when starting force guide object other than Decision object and SPELFunc object for the first time in the force guide sequence.

Value	Description
True	Reset the Force Sensor when starting a force guide object other than Decision object and SPELFunc object.
False	Force Sensor is not reset.

Default: True

- **MPNumber Property**
This property sets the number of Mass Property Object which is used during the force guide sequence execution.
Mass Property Object is a collection of properties using for gravity compensation. You need to define Mass Property Object in advance. If an angle will change largely during the execution of the force guide sequence, make sure to specify the proper Mass Property Object.

Value	Description
0	Turn OFF the gravity compensation.
1 to 15	Use the specified Mass Property.

Default: 0

- **PointFile Property**
This property sets the point file name that is used during the force guide sequence execution.

If the point file which is not specified by this property is loaded when the force guide sequence starts, an error occurs. This is a property for preventing a wrong operation.

Value	Description
None	Not specified (Any point file whichever loads can be executed without checking it.)
Point file name	An error occurs when the specified point file is not loaded.

Default: None

■ RobotTool Property

This property sets the Tool coordinate system number that is used during the force guide sequence execution.

If the Tool coordinate system number which is not specified by this property is selected when the force guide sequence starts, an error occurs. This is a property for preventing a wrong operation.

Value	Description
0 to 15	An error occurs when the set tool number is not selected.

Default: 0

■ InspectMethod Property

This property sets a height inspect method.

When you set DistInspect, the inspection is performed by the distance from the inspection start point to the contact point with the workpiece. ForceOrient of the force guide sequence is "Tool".

When you set PosInspect, the inspection is performed by the point when the robot contacted with the workpiece.

ForceOrient of the force guide sequence is "Base" or "Local".

Value	Description
DistInspect	Inspects by the distance from the inspection start point to the contact point with the workpiece.
PosInspect	Inspects by the robot posture when the robot contacted with the workpiece.

Default: DistInspect

■ ForceOrient Property

This property specifies the direction of coordinate system that uses the force control functions during the force guide sequence execution.

When "DistInspect" is set in InspectMethod of the force guide sequence, ForceOrient is "Tool". It cannot be edited.

When Tool is set, when the orientation of the robot changes, the direction of the tool coordinate system changes, and the direction of height inspection changes.

When "PosInspect" is set in InspectMethod of the force guide sequence, you can set "Base" or "Local" to ForceOrient.

When Base or Local is set, the direction of height inspection does not change even if the orientation of the robot changes.

Value	Description
Base	The direction of the coordinate system to which the force control function is applied is the Base coordinate system
Local	The direction of the coordinate system to which the force control function is applied is the Local coordinate system
Tool	The direction of the coordinate system to which the force control function is applied is the Tool coordinate system

Default: Tool

■ RobotLocal Property

This property specifies the Local coordinate system number of coordinate system that applies the force control functions

during the force guide sequence execution.

It is used when ForceOrient property is Local.

Value	Description
0 (Base)	Use the Local 0 coordinate system (Base coordinate system). It is the same as when specifying Base in ForceOrient.
1 to 15	Use the Local coordinate system of the specified number.

Default: 0 (Base)

- **RotationCenterTLX Property**

This property sets a distance in X direction from Tool coordinate system to the rotation center of the force control function. It is the X direction of the Tool coordinate system which is selected in RobotTool.

	Value (Unit: [mm])
Minimum Value	-2000
Maximum value	2000

Default: 0

- **RotationCenterTLY Property**

This property sets a distance in Y direction from Tool coordinate system to the rotation center of the force control function. It is the Y direction of the Tool coordinate system which is selected in RobotTool.

	Value (Unit: [mm])
Minimum Value	-2000
Maximum value	2000

Default: 0

- **RotationCenterTLZ Property**

This property sets a distance in Z direction from Tool coordinate system to the rotation center of the force control function. It is the Z direction of the Tool coordinate system which is selected in RobotTool.

	Value (Unit: [mm])
Minimum Value	-2000
Maximum value	2000

Default: 0

- **LimitSpeedS Property**

This property sets the maximum speed during the execution of force guide sequence.

The robot motion will change depending on applied force and torque when executing the force guide sequence since it is adjusted by the force control functions. However, it is restricted by the speed which is specified by this property.

	Value (unit: [mm/sec])
Minimum Value	0.1
Maximum value	250

Default: 50

- **LimitSpeedR Property**

This property sets the maximum rotation speed during the execution of force guide sequence.

The robot motion will change depending on applied force and torque when executing the force guide sequence since it is adjusted by the force control functions. However, it is restricted by the rotation speed which is specified by this property.

	Value (unit: [deg/sec])
Minimum Value	0.1
Maximum value	180

Default: 25

▪ LimitAccelS Property

This property sets the maximum acceleration during the execution of force guide sequence.

The robot motion will change depending on applied force and torque when executing the force guide sequence since it is adjusted by the force control functions. However, it is restricted by the acceleration which is specified by this property.

	Value (unit: [mm/sec ²])
Minimum Value	0.1
Maximum value	25000

Default: 200

▪ LimitAccelR Property

This property sets the maximum rotation acceleration during the execution of force guide sequence.

The robot motion will change depending on applied force and torque when executing the force guide sequence since it is adjusted by the force control functions. However, it is restricted by the rotation acceleration which is specified by this property.

	Value (unit: deg/sec ²)
Minimum Value	0.1
Maximum value	5000

Default: 100

▪ LogRobotLocal Property

For the positional orientation of the robot that is recorded during the force guide sequence execution, set a reference local coordinate system number.

The position of the robot is recorded as that of Tool coordinate system as viewed from the Local coordinate system specified by this property.

Value	Description
0 (Base)	Use the Local 0 coordinate system (Base coordinate system).
1 to 15	Use the Local coordinate system of the specified number.

Default: 0 (Base)

▪ LogFileEnabled Property

This property sets whether to save the force, torque, and the position of the robot during the force guide sequence execution in files.

When specifying True, value will be displayed in the graph on the monitor and saved in the files simultaneously.

When specifying False, value will be displayed in the graph on the monitor. However, the value is not saved in the files.

Value	Description
True	Save the log data in a file.
False	The log data is not saved in a file.

Default: False

▪ LogFileAutoName Property

This property sets whether to automatically set the file name that records force, torque, and the position of the robot during the force guide sequence execution.

When specifying True, the file name is automatically set with the force guide sequence name + start time.

Force guide sequence name_yyyymmdd_hhmmssfff.csv

When specifying False, add ".csv" to the string in variables which is specified in LogFileNameVar to make it a file name.

Value	Description
True	Set the name of the log data file automatically.
False	Set a log data file name to the one which is specified by LogFileNameVar.

Default: True

▪ LogFileNameVar Property

This property sets a global string variable that saves a file name which records force, torque, and the position of the robot during the force guide sequence execution.

It is used when False is specified in LogFileAutoName. Add ".csv" to the string in variables and set it as a file name.

Value	Description
None	Not specified (automatically set)
Variable name	Value of the specified global string variable will be a file name. Only a string variable can be specified.

Default: None

▪ LogFileInterval Property

This property sets the sampling period for the files that record force, torque, and the position of the robot during the force guide sequence execution.

	Value (unit: [sec])
Minimum Value	0.002
Maximum value	1

Default: 0.2

▪ LogFileMaxTime Property

This property sets the maximum recording time for the files that record force, torque, and the position of the robot during the force guide sequence execution.

If the specified recording time is shorter than the execution time of the force guide sequence, nothing is recorded in the file after the recording time is passed. note that

	Value (unit: [sec])
Minimum Value	60
Maximum value	600

Default: 60

4.4.5.2.3 Details on results of HeightInspect sequence

▪ EndStatus Result

It is a result of the execution.

Result will be succeeded when the force guide sequences are executed to the end and the final force guide object is succeeded or AbortSeqOnFail property of the final force guide object is False.

Value	Description
Passed	Force guide sequence is succeeded.
Failed	Force guide sequence is failed.
NoExec	Force guide sequence is not executed.
Aborted	Aborted during the execution of force guide sequence.

▪ FailedStatus Result

It is the reason why the force guide sequence failed.

It is the reason for failure when the result of executing an object with AbortSeqOnFail set to True.

Value	Description
OK	Force guide sequence is succeeded.
GeneralObjectFailed	General object is failed.
ContactFailed	Failed due to the position does not reach the destination.
PosConditionFailed	Failed due to the position is out of the range of success conditions.
Overrun	Failed due to overrun.

▪ Time Result

This is the time required for execution.

Unit: [sec]

▪ LastExecObject Result

Force guide object name which is executed at the end.

▪ EndForces Result

Force and torque when force guide sequence ends. Acquire values of Fx, Fy, Fz, Tx, Ty, and Tz.

Unit: Fx, Fy, Fz [N] / Tx, Ty, Tz [N · mm]

▪ PeakForces Result

Peak values of force and torque during the force guide object execution. The peak value is a value which absolute value is the largest. Acquire values of Fx, Fy, Fz, Tx, Ty, and Tz.

Unit: Fx, Fy, Fz [N] / Tx, Ty, Tz [N · mm]

▪ MeasuredHeight Result

When ForceOrient is set to "Tool", it is the distance from the operation start point. When ForceOrient is set to "Base, or Local", it is the position of the inspection direction set by ContactOrient of the HeightInspect object as seen from the coordinate system set by ForceOrient.

Unit:[mm]

4.4.5.3 HeightInspect Object

The HeightInspect object is a force guide object used to move the robot to the specified direction, and detect the contacted point contacted with a specified amount of force.

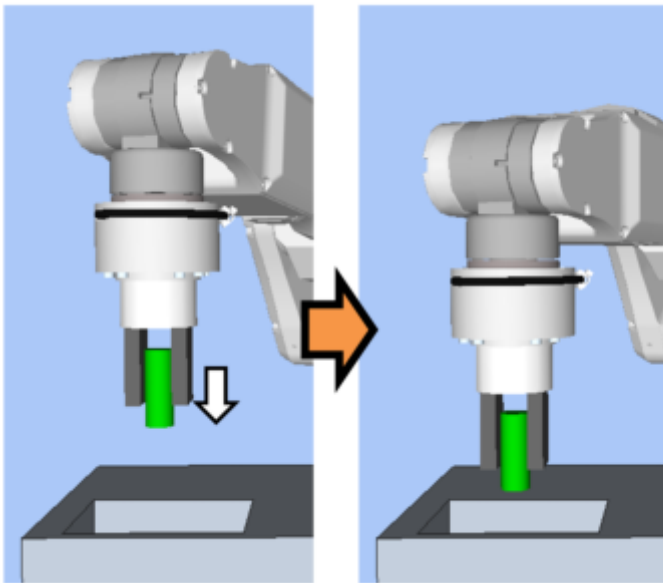

The diagram above provides a visual representation of a HeightInspect object. Executed from a non-contact state, moves to the direction depicted by the white arrow, and stop at the contacted point.

The HeightInspect object succeeds or fails when the end conditions are met within the specified time. The HeightInspect object can apply end conditions related to force and position.

Each end condition is always applied.

When all the success conditions for each end condition are met: The HeightInspect object execution ends. The execution is determined as succeeded and proceed to the next force guide object.

When at least one of the failure conditions for each end condition is met: The HeightInspect object execution ends. The execution is determined as failed and abort the force guide sequence.

End condition	Success condition
End conditions related to force	Within the specified time of Timeout, reach the force specified by ContactForceThresh in the axial direction specified by ContactOrient
End conditions related to position	Satisfy the following within the specified time of Timeout.
	When the height inspection method is set to be inspected by distance (Tool): The moving distance from the force guide object start point in the axial direction specified by ContactOrient exceeds the range of DistExpected - DistExpectedTol to DistExpected + DistExpectedTol.
	When the height inspection method is set to be inspected by position (Base, Local): The position when the workpiece touches in the axial direction specified by ContactOrient in the specified coordinate system is within the range of PosExpected - PosExpectedTol to PosExpected + PosExpectedTol.

End condition	Failure condition
End conditions related to position	Satisfy the following within the specified time of Timeout.
	When the height inspection method is set to be inspected by distance (Tool): The moving distance from the force guide object start point in the axial direction specified by ContactOrient exceeds DistExpected + DistCheckTol.
	When the height inspection method is set to be inspected by position (Base, Local): The position when the workpiece touches in the axial direction specified by ContactOrient in the specified coordinate system exceeds PosExpected + PosExpectedTol.
	When the inspection method is set to be inspected by position (Base, Local) and the direction of operation is negative: The position when the workpiece touches in the axial direction specified by ContactOrient in the specified coordinate system exceeds PosExpected- PosExpectedTol.

4.4.5.3.1 Property guidelines for HeightInspect object

Step 1. Set basic information

Set properties (Name, Description, StepID, AbortSeqOnFail) related to the basic information.

Properties	Description, setting guide
Name	This property sets names of force guide objects. Set a particular name.
Description	This property sets descriptions about force guide objects. Describe the operations. Set a character string.
StepID	StepID during the force guide object execution. Set an ID. StepID is an ID which is recorded in the log data. It helps you to understand which log data support a process. It is applied when AutoStepID of the force guide sequence is False.
AbortSeqOnFail	Set whether to abort or continue the force guide sequence when the force guide object fails.
	True : Normal End a force guide sequence.
	False : Cases where the force guide sequence contains recovery operations in case of failure; cases where the sequence will be able to continue even in the event of a failure.

Step 2. Set contact direction and force control functions

Set properties (ContactOrient, ContactFirmnessF) related to the contact direction and the force control functions.

Properties	Description, setting guide
ContactOrient	Set a direction to contact. The robot moves to the specified direction.
ContactFirmnessF	Set a firmness of the force control functions.
	When setting a large value: The Force Control functions become stronger, but response to changes in force is slow.

Properties	Description, setting guide
	When setting a small value: The Force Control function will become weaker. Response to changes in force is fast; however, vibrations can easily occur.

You can check the settings of ContactOrient by a simulator. A coordinate system with grayed out except the specified direction is displayed.

However, the robot is displayed based on the current position. When you check the settings, make sure to move the robot to the position where executing the force guide object.

For details on how to check by using simulator, refer to the following manual.

"Epson RC+ 8.0 User's Guide: - Simulator - Description of Functions"

Step 3. Set the end conditions

Set properties (ContactForceThresh, Timeout) related to the end conditions.

Properties	Description, setting guide
ContactForceThresh	Set a threshold to determine a contact. Set this to a tolerable value considering the workpiece in use.
	When setting a large absolute value: Movement speed until the robot makes contact will be fast.
	When the value is too small: Robot may not move.
Timeout	Set a time-out period of the HeightInspect object. It fails if the specified time is passed before contacting.

Step 4. Set success conditions

Set properties (DistExpected, DistExpectedTol, PosExpected, PosExpectedTol) related to success conditions.

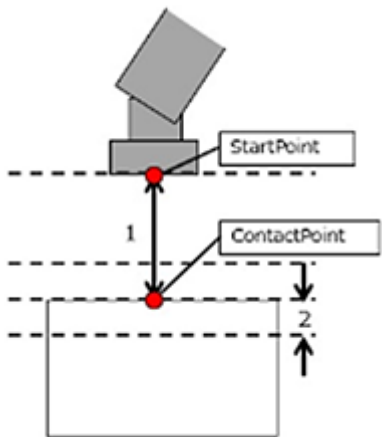
Properties	Description, setting guide
DistExpected	<p>Set a reference distance to the expected point of contact from the start point of the motion. This is the moving distance in the direction set by the HeightInspect object ContactOrient in the coordinate system set by the ForceOrient property for the HeightInspect sequence. The inspection reference distance is distance 1 from the start point of the motion indicated by the red dot at the top of the diagram below, to the contact point represented by the red dot at the bottom.</p>  <p>If DistInspect is set as the InspectMethod for the HeightInspect sequence, it will be used as a success condition.</p>

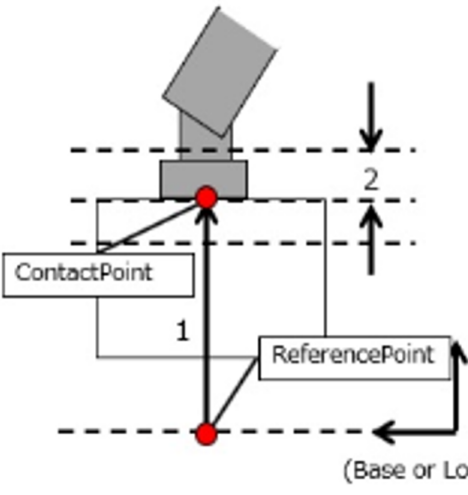
Properties	Description, setting guide
	<p>Teach the robot a start point of the motion that shortens the inspection reference distance as much as possible. As the force control function is slower than position control, longer inspection reference distances will result in longer cycle times.</p>
<p>DistExpectedTol</p>	<p>Set a tolerance of the reference distance to the expected point of contact from the start point of the motion.</p> <p>The diagram below provides a visual representation of the DistExpectedTol property.</p>  <p>If "DistInspect" is set as the InspectMethod for the HeightInspect sequence, it will be used as a success condition.</p>
<p>PosExpected</p>	<p>Set an expected point of contact.</p> <p>This is the position in the direction set by the HeightInspect object ContactOrient in the coordinate system set by the ForceOrient property for the HeightInspect sequence.</p> <p>The inspection reference point is the point of contact depicted by the red dot at the top of the diagram below.</p>  <p>If "PosInspect" is set as the InspectMethod for the HeightInspect sequence, it will be used as a success condition.</p>

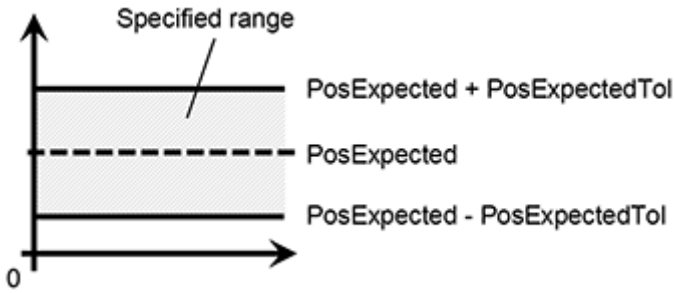
Properties	Description, setting guide
PosExpectedTol	<p>Set a tolerance for the expected point of contact. The diagram below provides a visual representation of the PosExpectedTol property.</p>  <p>If "PosInspect" is set as the InspectMethod for the HeightInspect sequence, it will be used as a success condition.</p>

4.4.5.3.2 Details on properties of HeightInspect object

- Name Property**
This property sets a particular name that is assigned to force guide object.
When creating the HeightInspect sequence, name is assigned automatically. Automatically assigned name is added a number after HeightInspect (e.g. HeightInspect01).
You can change the name. Set up 16 characters at the maximum. Please use alphanumeric characters and underscores [_].
Note: The initial character cannot be a numeric character.

- Description Property**
This property sets descriptions about force guide objects. You can set the character string up to 255 characters.

- StepID Property**
This property sets StepID during the execution of the force guide objects.
It is only used when AutoStepID is False.

	Value
Minimum Value	0
Maximum value	32767

Default: Automatically set according to the numbers of the force guide sequence and the force guide object.

- AbortSeqOnFail Property**
This property sets operations when force guide object fails.
When True is specified: If the force guide object fails, the program ends the force guide sequence and proceeds to the next SPEL statement.
When specifying False: If force guide object fails, the program proceeds to the next force guide object without ending the force guide sequence.
Use this property when you want to continue the force guide sequence (e.g. the recovery processes are included in the force guide sequence when the force guide object fails.)

Value	Description
True	Abort the force guide sequence when the force guide object fails.
False	Start the next force guide sequence when the force guide object fails.

Default: True

- ContactOrient Property**
This property sets the direction of motion for height inspection operations in the coordinate system specified by the

ForceOrient property for the force guide sequence. The robot moves to the specified direction, and when the robot contacts something, stops.

Value	Description
+Fx	Sets the direction of motion to the +Fx direction in the specified coordinate system.
-Fx	Sets the direction of motion to the -Fx direction in the specified coordinate system.
+Fy	Sets the direction of motion to the +Fy direction in the specified coordinate system.
-Fy	Sets the direction of motion to the -Fy direction in the specified coordinate system.
+Fz	Sets the direction of motion to the +Fz direction in the specified coordinate system.
-Fz	Sets the direction of motion to the -Fz direction in the specified coordinate system.

Default: +Fz

■ ContactFirmnessF Property

This property sets the firmness in relation to the force control function in the direction of motion specified by the ContactOrient property for the force guide object during the execution of the force guide object.

The larger the ContactFirmnessF value, the stronger the force control function becomes in the direction of motion. This slows response to changes in force, but reduces vibration.

The smaller the ContactFirmnessF value, the weaker the force control function becomes in the direction of motion. This speeds up response to changes in force, but increases vibration.

	Value
Minimum Value	0.1
Maximum value	10

Default: 1.5

■ ContactForceThresh Property

This property sets a threshold of force to determine the contact.

If the threshold set by this property is exceeded during execution of HeightInspect object, the robot recognizes that the robot is contacted and stops the motion. Then, proceed to the next force guide object.

- When ContactOrient is in positive direction:

	Value (unit: [N])
Minimum Value	-10
Maximum value	-0.1

Default: -2

- When ContactOrient is in negative direction:

	Value (unit: [N])
Minimum Value	0.1
Maximum value	10

Default: 2

■ DistExpected Property

This property sets the distance from the height inspection start point to the position to be contacted. Use this property when DistInspect is set for the InspectMethod property of the force guide sequence.

	Value (Unit: [mm])
Minimum Value	0
Maximum value	50

Default: 10

■ DistExpectedTol Property

Specify the range that is the success condition (when the operation is finished) of the distance moved from the operation start position.

The success condition is the range of DistExpected - DistExpectedTol to DistExpected + DistExpectedTol

	Value
Minimum Value	0.01
Maximum value	10

Default: 1

■ PosExpected Property

This property sets the position to be contacted. Use when PosInspect is set for the InspectMethod property of the force guide sequence.

	Value (Unit: [mm])
Minimum Value	-2000
Maximum value	2000

Default: 100

■ PosExpectedTol Property

This property sets the range that is the success condition of the contacted distance when the operation is finished.

The success condition is the range of PosExpected - PosExpectedTol to PosExpected + PosExpectedTol

	Value
Minimum Value	0.01
Maximum value	10

Default: 1

■ Timeout Property

This property sets the time-out period of the force guide object.

When the robot does not satisfy the conditions set by ContactForceThresh even the time specified by Timeout has passed, it determines as failure of the HeightInspect object.

After the determination, end the force guide sequence according to AbortSeqOnFail or proceed to the next force guide object.

	Value (unit: [sec])
Minimum Value	0.1
Maximum value	60

Default: 10

4.4.5.3.3 Details on results of HeightInspect object

- EndStatus Result

It is a result of the execution.

It will be succeeded when satisfying "success conditions" described in

[HeightInspect Object](#)

Value	Description
Passed	Force guide object is succeeded.
Failed	Force guide object is failed.
NoExec	Force guide object is not executed.
Aborted	Aborted during the execution of force guide object.

- Time Result

This is the time required for execution.

Unit: [sec]

- TimedOut Result

Shows whether the time-out period set in the Timeout property was reached.

Value	Description
True	Reached the time-out period.
False	End before reaching to the time-out period.

- EndForces Result

It is force and torque when force guide object ends. Acquire values of Fx, Fy, Fz, Tx, Ty, and Tz.

Unit: Fx, Fy, Fz [N] / Tx, Ty, Tz [N · mm]

- EndPos Result

Positions when the force guide object ends. Acquire values of X, Y, Z, U, V, and W.

Unit: X, Y, Z [mm] / U, V, W [deg]

- AvgForces Result

Average values of force and torque during the force guide object execution. Acquire values of Fx, Fy, Fz, Tx, Ty, and Tz.

Unit: Fx, Fy, Fz [N] / Tx, Ty, Tz [N · mm]

- PeakForces Result

Peak values of force and torque during the force guide object execution. The peak value is a value which absolute value is the largest. Acquire values of Fx, Fy, Fz, Tx, Ty, and Tz.

Unit: Fx, Fy, Fz [N] / Tx, Ty, Tz [N · mm]

- ForceCondOK Result

Shows whether the end conditions related to force were satisfied.

Value	Description
True	Satisfy the end conditions related to force.
False	The end conditions related to force are not satisfied.

- TriggeredForces Result

It is the force and torque when satisfying the end conditions related to force. Acquire values of Fx, Fy, Fz, Tx, Ty, and Tz.

Unit: Fx, Fy, Fz [N] / Tx, Ty, Tz [N · mm]

- TriggeredPos Result

Positions when satisfying the end conditions related to force. Acquire values of X, Y, Z, U, V, and W.

Unit: X, Y, Z [mm] / U, V, W [deg]

■ PosCondOK Result

Value	Description
True	Satisfy the end conditions related to position.
False	The end conditions related to position are not satisfied.

■ PosLimited Result

Shows whether the limit range related to position was exceeded.

Value	Description
True	Exceed the limit range related to position.
False	The limit range related to position is not exceeded.

4.4.5.4 Adjustment Guidelines for the HeightInspect Sequence and Object Property Values

The following section describes how to adjust when using HeightInspect sequence and objects.

- If GeneralObjectFailed appears as the FailedStatus result:
A failure has occurred with a general object placed in the HeightInspect sequence. The last executed object appears in the LastExecObject result. Adjust the property of the object that appears here by referring to the property setting guideline or adjustment guideline for the property.
- If ContactFailed appears as the FailedStatus result:
Decrease the Firmness value of the height inspection direction.
However, the robot motion may be easy to vibrate. Please perform proper adjustments for your operations.
To adjust the Firmness, we recommend changing the value gradually (e.g. decrease the value by 10% from its current state).
If the robot still bounces, increase the value of Timeout.
- If PosConditionFailed appears as the FailedStatus result:
A failure has occurred because the position did not meet the position success condition set by the object during HeightInspect object execution.
Conform the set DistExpected, DistExpectedTol, or PosExpected, PosExpectedTol with the specifications of the actual environment and workpiece.
- If Overrun appears as the FailedStatus result:
Even though the position exceeded the position success condition range set by the object during HeightInspect object execution, a position overrun was detected and a failure has occurred because the motion executed without enough force to satisfy the force success condition.
Conform the set DistExpected or PosExpected with the specifications of the actual environment and workpiece.
- When the contacting force is large:
Decrease the value of ContactForceThresh. Or, increase the value of ContactFirmnessF.
However, the movement speed will be slow. Please perform proper adjustments for your operations.
- When the force guide object ends before contacting:
If the execution time is short, increase Timeout value.
- When incorrectly determining as "contacted" before contacting:
Contact object determines incorrectly due to the inertia force or noise when moving.
Increase the value of ContactForceThresh. However, force when contacting will be large. Please perform proper

adjustments for your operations.

Or, increase the value of ContactFirmnessF. However, the movement speed will be slow. Please perform proper adjustments for your operations.

- When the movement speed until the robot contacts is slow:
Increase the value of ContactForceThresh. Or, decrease the value of ContactFirmnessF.
However, force when contacting will be large, or vibrations may be generated. Please perform proper adjustments for your operations.
- When it takes time to contact:
If the start position of the force guide object is far from a contact position, it takes time since moving distance is long.
Change the start position to a position where is as close as possible to the position to be contacted, but where does not contact with the position.
- When the robot does not move to the contacting direction or move to an opposite direction:
The Force Sensor may not be reset properly. Check the ResetSensor setting of the force guide sequence.
When starting the force guide sequence, the object may start with the contact state. Be sure to start from the non-contact state.
The absolute values of ContactForceThresh may be small. Increase the absolute value. However, force when contacting will be large. Please perform proper adjustments for your operations.

4.4.6 Insert Sequence and Object

The Insert sequence is a function used to move the robot by pressing in a specified direction with a specified amount of force while simultaneously following another direction. This is used to insert a gripped workpiece into a hole. Once inserted, you can also check that the workpiece cannot be removed by applying a set amount of force in the opposite direction, such as when using a connector.

An Insert sequence is composed of two objects - an Insert object, and a TensileTest object. General force guide objects can also be added depending on the work procedure.

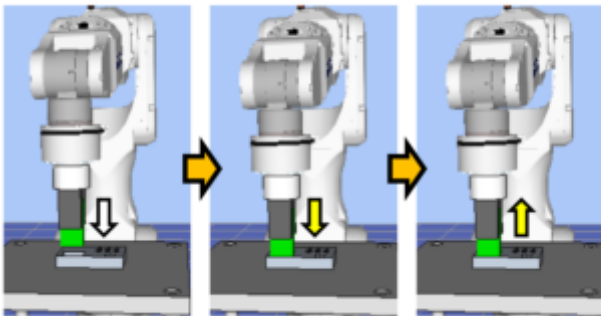

The diagram above provides a visual representation of an Insert sequence. Executed from a non-contact state, this sequence moves the robot in the pressing direction depicted by the white arrow. From the point of contact, the robot continues to apply a set amount of force in the direction shown by the yellow arrow. The motion procedure up to this point is executed by an Insert object.

After this, the robot continues to apply a set amount of force in the opposite direction to the pressing direction, as shown by the yellow arrow. This motion is executed by a TensileTest object.

This chapter covers the sequence wizards and properties of Insert sequence, Insert objects, and TensileTest objects, and describes how to configure them.

For more information about general force guide objects, see the next section.

Software [General force guide object](#)

4.4.6.1 Sequence Wizard for an Insert Sequence

Use the sequence wizard to create an Insert sequence. This sequence wizard can be displayed by doing the following.

- Right click the sequence flow in the flowchart, or the sequence node in the sequence tree, and then select [Sequence Wizard].
- Click the  button shown to the right of the [Click to open->] Wizard setting in the Insert sequence property.

When the sequence wizard appears, configure settings as instructed on the screen.

The sequence wizard for an Insert sequence can also be configured on the new sequence screen for creating a new force guide sequence. For the details, refer to the following section.

Software [Force Guidance] [\[Tools\] menu](#)

- Create a new force guide sequence - Sequence Wizard, Create a new system force guide sequence

Step 1. Select the robot tool to use for the end effector

Select the tool number to be used for the Insert sequence, Insert object, and TensileTest object.

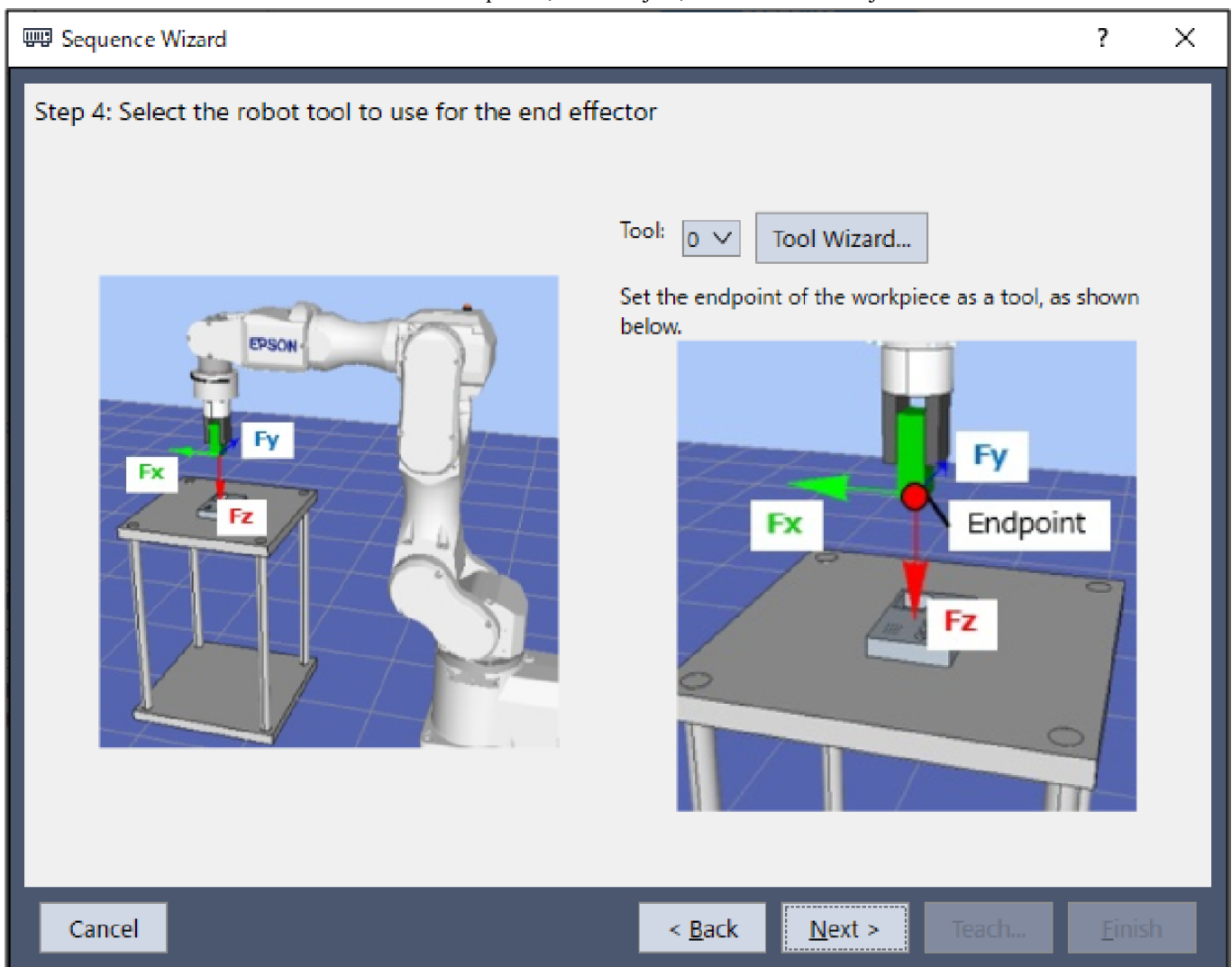

Item	Description, setting guide
Tool	Select the tool number to be used. Select a tool number so that the end point of the workpiece is at the tool origin point. Tool numbers set are sorted in the list. To set a new tool, use the Tool Wizard button. "Epson RC+ 8.0 User's Guide - Epson RC+ 8.0 GUI - [Tools] menu, [Tools] - [Robot Manager] - [Tool Settings] panel" Minimum value: 0 Maximum value: Maximum value for the set tool number Default: 0
[Cancel] button	Cancels a new Insert sequence creation. Click it to end a sequence wizard.
[Back] button	When opening from the new sequence creation screen, you can return to the previous Step.
[Next] button	Proceeds to the next Step.
[Finish] button	You cannot click this button.

Step 2. Set tool offsets

When the tool set in Step 1 is not set in the center of the workpiece tip, this setting is required. Set the offset amount from the tool to the center of the workpiece tip.

Sequence Wizard
?
×

Step 5: Set tool offsets

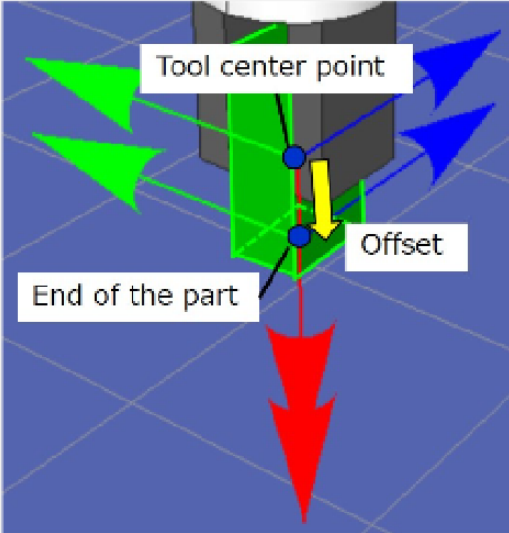

Use the offsets if the tool is not the endpoint of the part.

Set the offsets from X and Y center of the robot tool to the X and Y center of the part. In addition, set the Z offset from the end of the robot tool to the end of the part.

X Offset: mm

Y Offset: mm

Z Offset: mm

Cancel
< Back
Next >
Teach...
Finish

Item	Description, settings guide
X Offset	Sets the offset amount in the X direction from the tool set in Step 1 to the tip of the workpiece. Minimum value: -2000.000 [mm] Maximum value: 2000.000 [mm] Default: 0.000[mm]
Y Offset	Sets the offset amount in the Y direction from the tool set in Step 1 to the tip of the workpiece. Minimum value: -2000.000 [mm] Maximum value: 2000.000 [mm] Default: 0.000[mm]
Z Offset	Sets the offset amount in the Z direction from the tool set in Step 1 to the tip of the workpiece. Minimum value: -2000.000 [mm] Maximum value: 2000.000 [mm] Default: 0.000[mm]
[Cancel] button	Cancels a new Insert sequence creation. Click it to end a sequence wizard.
[Back] button	Returns to the previous Step.
[Next] button	Proceeds to the next Step.
[Finish] button	You cannot click this button.

Step 3. Set insert coordinate system and direction

Set the insert direction.

Select "Tool" to perform the insert operation that matches the orientation when starting the sequence.

Select "Base or Local" to perform the insert operation in the direction that matches the workpiece regardless of the orientation

when starting the sequence.

Sequence Wizard

Step 6: Set insert coordinate system and direction

- Run the insertion in the tool coordinate system
- Run the insertion in the selected base or local coordinate system

Robot local: Base

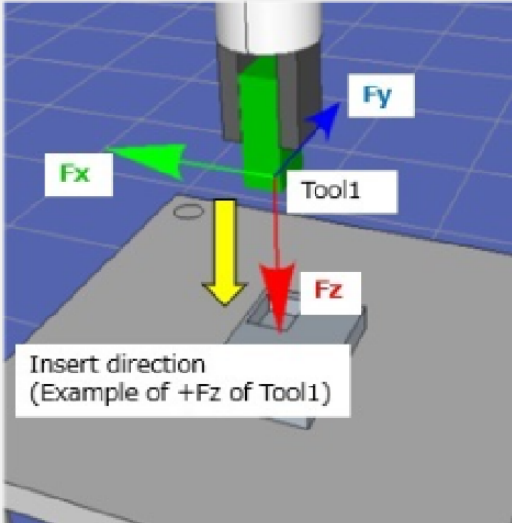
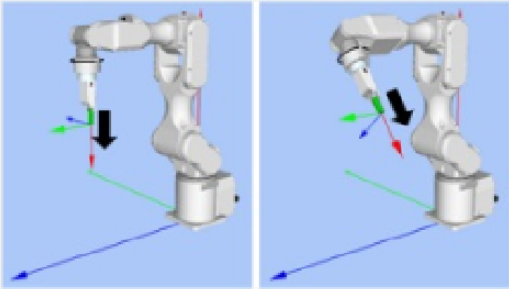

Cancel < Back Next > Teach... Finish

Item	Description, setting guide
Robot local	<p>Select the coordinate system used by the Insert sequence.</p> <p>When the insert coordinate system is set to "Base" or "Local", the robot will move in the corresponding coordinate system. Select the coordinate system according to the orientation of the workpiece being inserted.</p> <p>Minimum value: Base (0)</p> <p>Maximum value: 15</p> <p>Default: Base</p>
Insert direction	<p>Select the direction of insertion.</p> <p>When the insert coordinate system is set to "Tool", the Insert sequence and Insert object will move in the direction of insertion selected for the tool coordinate system set in Step 1.</p> <p>When the insert coordinate system is set to "Base" or "Local", the Insert sequence and Insert object will move in the direction of insertion selected for the base or local coordinate system set as the coordinate system.</p> <p>The TensileTest object will move in the opposite positive or negative direction of the direction of insertion selected.</p> <p>Values: +Fx, -Fx, +Fy, -Fy, +Fz, -Fz</p> <p>Default: +Fz</p>
[Cancel] button	<p>Cancels a new Insert sequence creation.</p> <p>Click it to end a sequence wizard.</p>
[Back] button	<p>Returns to the previous Step.</p>
[Next] button	<p>Proceeds to the next Step.</p>
[Finish] button	<p>You cannot click this button.</p>

Step 4. Set insert operation options

Select whether to enable insertion alignment and tensile tests.

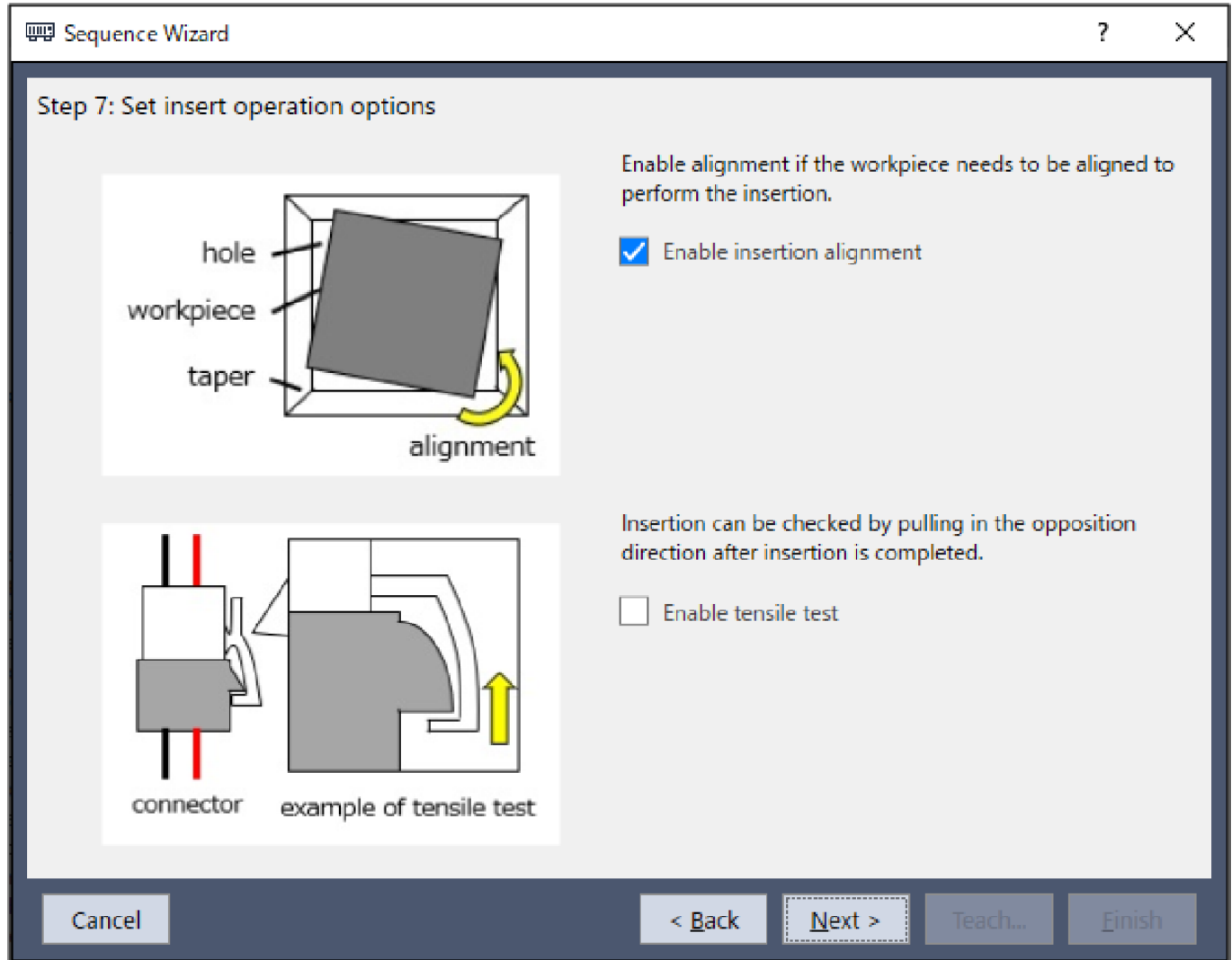

Item	Description, setting guide
Enable insertion alignment	Set whether to enable alignment between the workpiece and the hole. When enabled, the workpiece is aligned in the direction of the yellow arrow depicted in the top image in the wizard while the insert operation is in progress. Enable this for rectangular cylinder workpieces and other workpieces that cannot be inserted without being properly aligned. Default: Enabled
Enable tensile test	Set whether to perform a tensile test. Use this to determine whether a connector, or a similar workpiece, has been properly inserted by applying force in the opposite direction to the direction of insertion. Default: Disabled
[Cancel] button	Cancels a new Insert sequence creation. Click it to end a sequence wizard.
[Back] button	Returns to the previous Step.
[Next] button	Proceeds to the next Step.

Item	Description, setting guide
[Finish] button	You cannot click this button.

Step 5. Set insert approach distance and depth

Set the approach distance and depth for insertion.

Sequence Wizard
?
×

Step 8: Set insert approach distance and depth

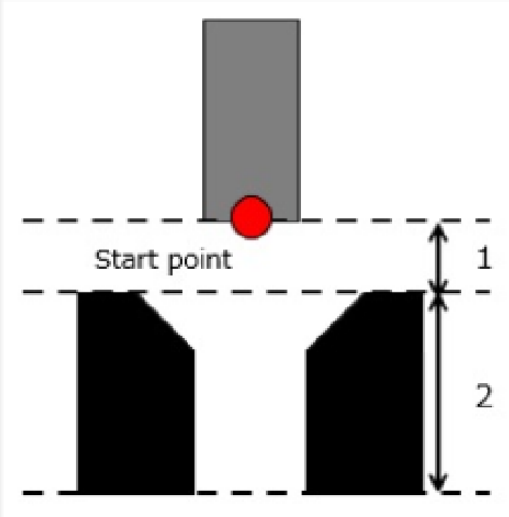

1. Approach distance: mm

The approach distance is the distance between the end point of the grasped part at the start of the sequence and the face of the hole.
Make the approach distance as short as possible. In general, the speed during force control is slower than position control, so the shorter the approach distance, the shorter the cycle time.
However, be careful to avoid collision, taking into account the variation of the part dimensions.

2. Insert depth: mm

Set the depth of the hole

Cancel
< Back
Next >
Teach...
Finish

Item	Description, setting guide
Approach distance	<p>Set an approach distance.</p> <p>The approach distance is distance 1 depicted in the diagram below, which is the distance between the end point of the gripped workpiece at the start of the Insert sequence indicated by the green dot in the diagram, and the opening of the hole.</p> <p>Teach the robot a start point of the motion that shortens the approach distance as much as possible. As the force control function is slower than position control, longer approach distances will result in longer cycle times.</p>

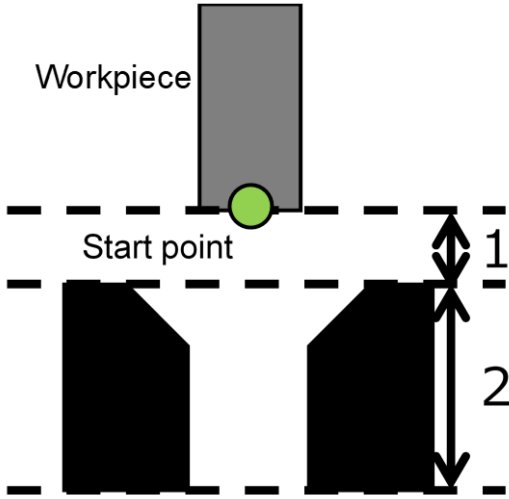

Item	Description, setting guide
	 <p>Workpiece</p> <p>Start point</p> <p>1</p> <p>2</p> <p>Minimum value: 0 [mm] Maximum value: 50 [mm] Default: 10[mm]</p>
Insert depth	<p>Set an insert depth.</p> <p>The insert depth is length 2, the depth of the hole part of the approach distance as depicted in the diagram.</p> <p>Minimum value: 0 [mm] Maximum value: 300 [mm] Default: 30[mm]</p>
[Cancel] button	<p>Cancels a new Insert sequence creation.</p> <p>Click it to end a sequence wizard.</p>
[Back] button	<p>Returns to the previous Step.</p>
[Next] button	<p>Proceeds to the next Step.</p>
[Finish] button	<p>You cannot click this button.</p>

Step 6. Set insertion parameters

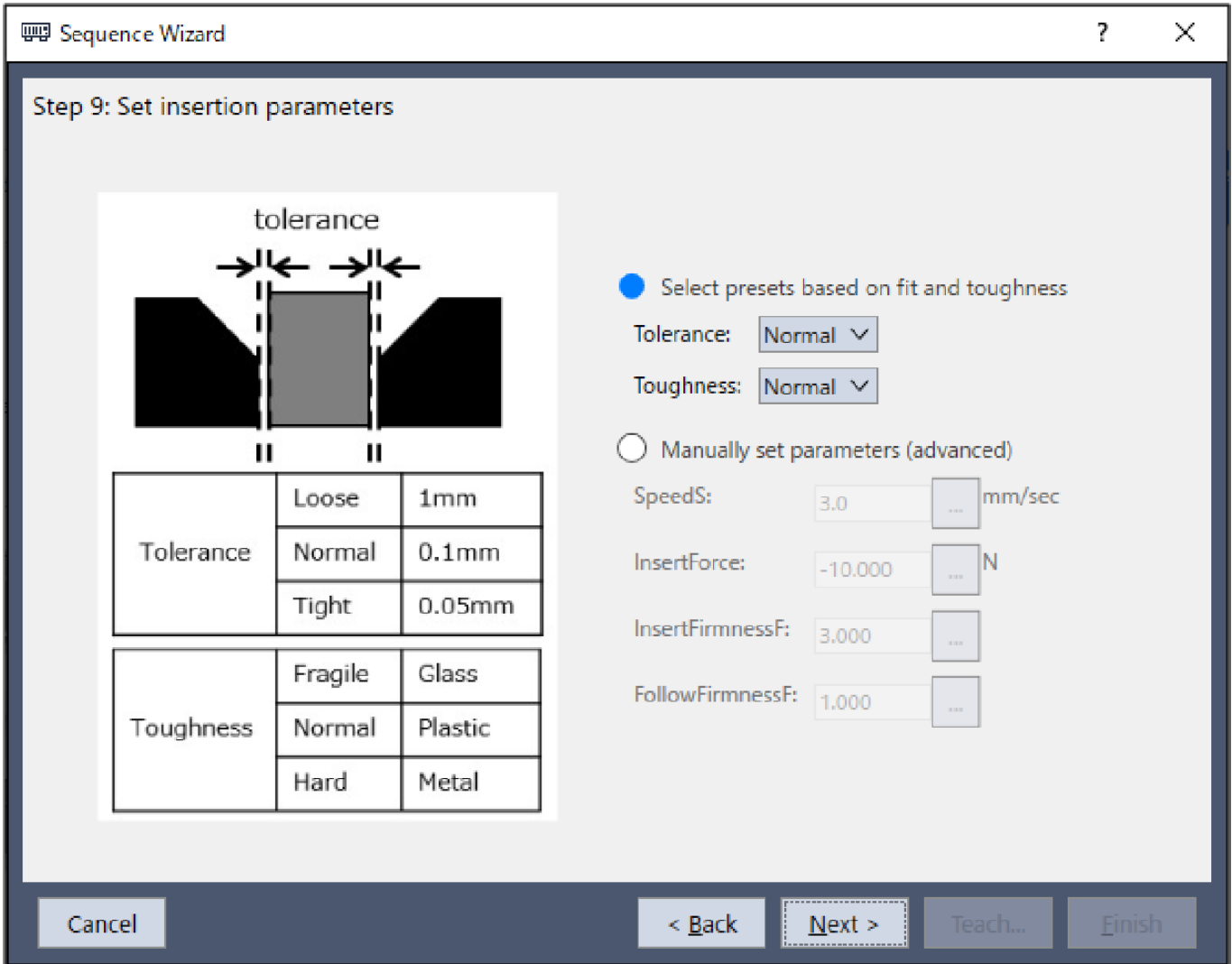
Set insertion parameters from the presets provided. While this property setting can be configured directly, this is for advanced users.



Item	Description, setting guide
Tolerance	<p>Select the tolerance between the gripped workpiece and the hole. Choose from three presets, "Loose", "Normal", and "Tight". A guideline for the different tolerance levels to choose from is provided below.</p> <p>Loose: 1 [mm] Normal: 0.1 [mm] Tight: 0.05 [mm]</p> <p>Selecting a looser tolerance will increase the insertion speed and the amount of pressing force. Conversely, selecting a tighter tolerance will reduce the insertion speed and weaken the pressing force.</p>
Toughness	<p>Select the material toughness of the workpiece and hole. Choose from three presets, "Fragile", "Normal", and "Hard". A guideline for the different levels of toughness to choose from is provided below.</p> <p>Fragile: Glass Normal: Plastic Hard: Metal</p> <p>Setting the toughness to "Fragile" will weaken the pressing force and reduce the reaction speed to force applied in the direction of insertion. Conversely, setting the toughness to "Hard" will increase the pressing force and increase the reaction speed to force applied in the direction of insertion.</p>



Item	Description, setting guide
SpeedS	<p>Set a translational speed of the robot during insertion. Actual speed is adjusted by the force control functions.</p> <p>This can be set by selecting advanced settings.</p> <p>Press the  button to adjust the speed using a slider.</p> <p>Minimum value: 0.1 [mm/sec] Maximum value: 100 [mm/sec] Default: 3.0 [mm/sec]</p>
InsertForce	<p>Set a force to insert in the insert direction. The actual force will be greater than the force set due to friction between the workpiece and the screw hole.</p> <p>This can be set by selecting advanced settings.</p> <p>Press the  button to adjust the insertion force using a slider.</p>
	<p>When the direction of insertion is in the positive direction: Minimum value: -50.0 [N] Maximum value: 0.0 [N] Default: -10.0 [N]</p> <p>When the direction of insertion is in the negative direction: Minimum value: 0.0 [N] Maximum value: 50.0 [N] Default: 10.0 [N]</p>
InsertFirmnessF	<p>Set the firmness of the force control functions in the insert direction.</p>
	<p>When setting a large value: The Force Control functions become stronger, but response to changes in force is slow.</p>
	<p>When setting a small value: The Force Control function will become weaker. Response to changes in force is fast; however, vibrations can easily occur.</p>
	<p>This can be set by selecting advanced settings.</p> <p>Press the  button to adjust the firmness using a slider.</p> <p>Minimum value: 0.1 Maximum value: 10 Default: 3.0</p>
FollowFirmnessF	<p>Set a firmness of the force control function following a translational force in a direction other than the direction of insertion.</p>
	<p>When setting a large value: The Force Control functions become stronger, but response to changes in force is slow.</p>
	<p>When setting a small value: The Force Control function will become weaker. Response to changes in force is fast; however, vibrations can easily occur.</p>

Item	Description, setting guide
	This can be set by selecting advanced settings. Press the  button to adjust the firmness using a slider. Minimum value: 0.1 Maximum value: 10 Default: 1.0
[Cancel] button	Cancels a new Insert sequence creation. Click it to end a sequence wizard.
[Back] button	Returns to the previous Step.
[Next] button	Proceeds to the next Step.
[Finish] button	You cannot click this button.

Step 7. Set insert follow firmness

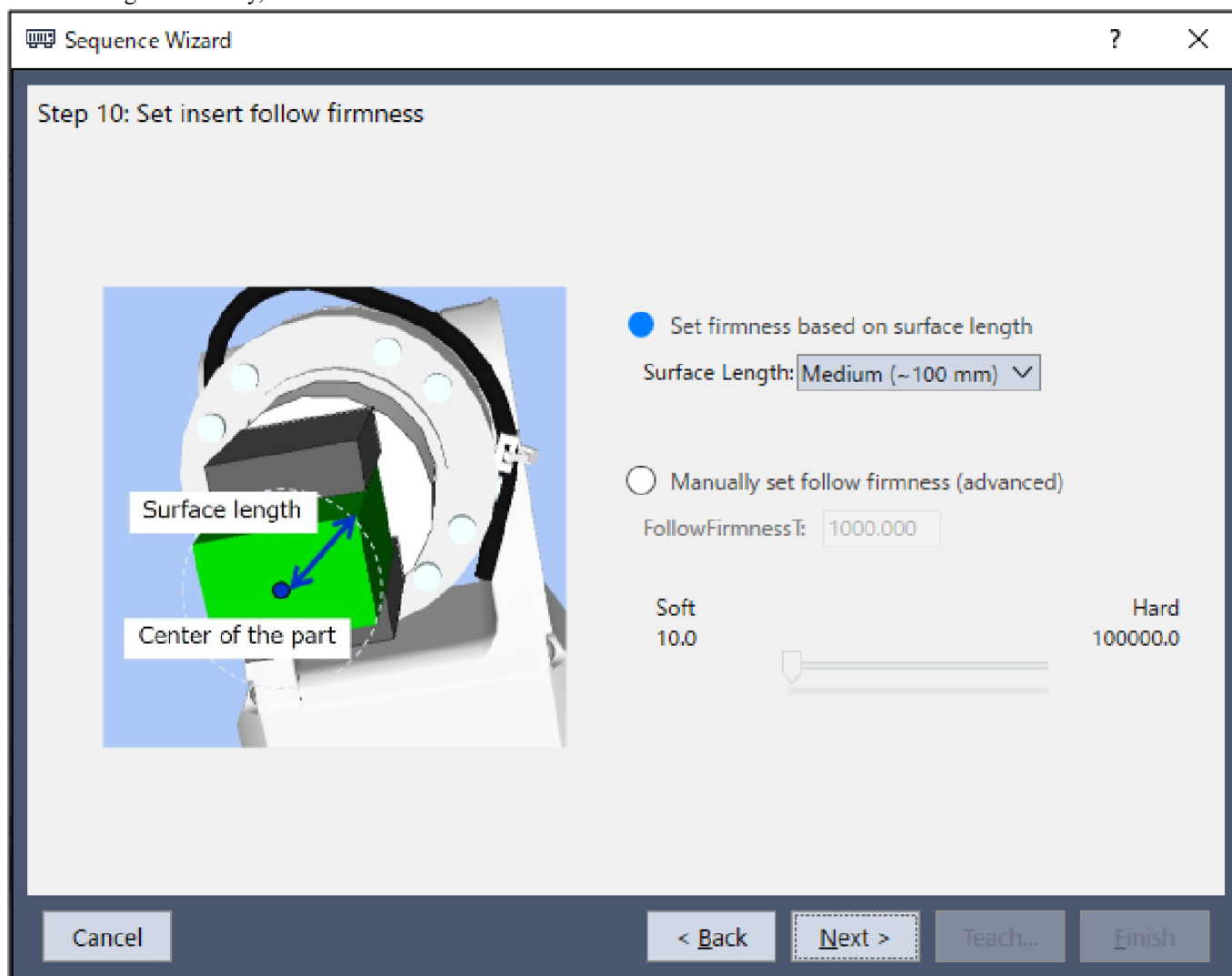
Use the presets to set the firmness of the force control function following the direction of rotation. While this property setting can be configured directly, this is for advanced users.

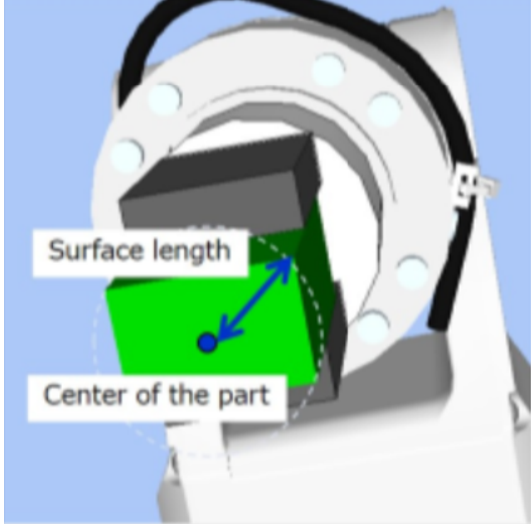

Item	Description, setting guide
Surface Length	<p>Select the length from the point of contact (the specified center point of the tool) to the end point of the workpiece. Choose from three presets, "Short", "Medium", and "Long". A guideline for the different tolerance levels to choose from is provided below.</p> <p>Short: up to 60 [mm] Medium: up to 100 [mm] Long: up to 200 [mm]</p> <p>The length is depicted by the blue arrow in the diagram below. This is the length of the radius of a circle from the center point (point of contact) to the most distant edge of the workpiece, thus large enough to fit the surface area of the workpiece.</p>  <p>The shorter this setting is, the faster the reaction following the direction of rotation. The longer this setting is, the slower the reaction following the direction of rotation.</p>
FollowFirmnessT	<p>Set a firmness of the force control functions in rotation direction.</p> <p>When setting a large value: The Force Control functions become stronger, but response to changes in force is slow.</p> <p>When setting a small value: The Force Control function will become weaker. Response to changes in force is fast; however, vibrations can easily occur.</p> <p>This can be set by selecting advanced settings. Press the  button to adjust the firmness using a slider. Minimum value: 10.0 Maximum value: 100000 Default: 1000</p>
[Cancel] button	<p>Cancels a new Insert sequence creation. Click it to end a sequence wizard.</p>
[Back] button	<p>Returns to the previous Step.</p>
[Next] button	<p>Proceeds to the next Step.</p>
[Finish] button	<p>You cannot click this button.</p>

Step 8. Configure the completion conditions for the insert operation

Configure the completion conditions for the insert operation.

Sequence Wizard
?
×

Step 11: Configure the completion conditions for the insert operation

Set the tolerances for insert force (2) and follow force and torque (3) that must be achieved for the specified duration (4).

2. Insert Force Tolerance: N

3a. Follow Force Tolerance: N

3b. Follow Torque Tolerance: N·mm

4. Completion Duration: sec

Cancel
< Back
Next >
Teach...
Finish

Item	Description, setting guide
Insert Force Tolerance	<p>The insertion direction range for the end condition related to force. Set a range of the end conditions. This monitors whether the force in the direction specified either by the Fx, Fy, or Fz insertion direction (InsertForce) is within the $\text{InsertForce} \pm \text{tolerance}$ range. For example, if the direction of insertion is set to +Fz, the force in the Fz direction will be monitored on whether its value is within this range. The following diagram provides a visual representation.</p> <div style="text-align: center; margin: 10px 0;"> </div> <p>The lower this tolerance value, the stricter success conditions are for the operation. It is recommended that you increase the tolerance, and then adjust it back based on actual operation results obtained.</p> <p>Minimum value: 0.1 [N] Maximum value: 10 [N] Default: 1.0 [N]</p>

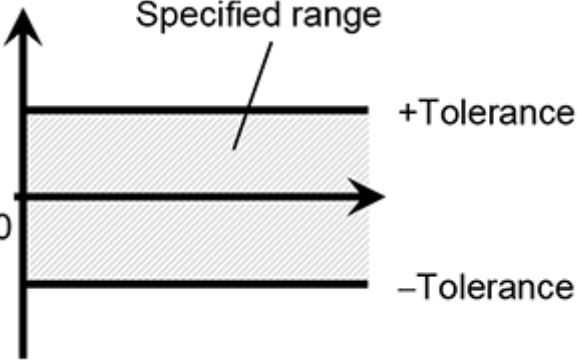
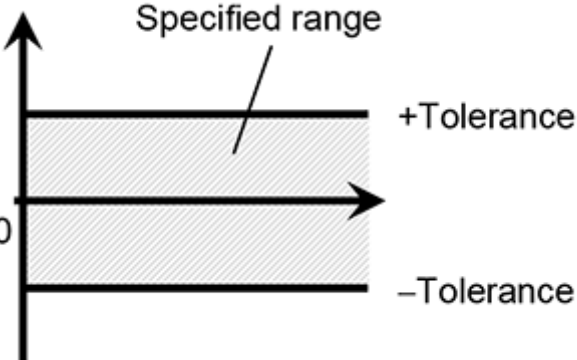
Item	Description, setting guide
<p>Follow Force Tolerance</p>	<p>The tolerance range for following motion in a direction other than the direction of insertion set as an end condition related to force. Set a range of the end conditions.</p> <p>This monitors whether the force in a direction other than that specified either by the Fx, Fy, or Fz insertion direction is within the tolerance range. For example, if the direction of insertion is set to +Fz, the force in the Fx and Fy directions will be monitored on whether its value is within this range.</p> <p>The following diagram provides a visual representation.</p>  <p>The lower this tolerance value, the stricter success conditions are for the operation. It is recommended that you increase the tolerance, and then adjust it back based on actual operation results obtained.</p> <p>Minimum value: 0.1 [N] Maximum value: 10 [N] Default: 1.0 [N]</p>
<p>Follow Torque Tolerance</p>	<p>Set the range to use as the end condition related to torque.</p> <p>This monitors whether the torque represented by Tx, Ty, or Tz is within the tolerance range. However, note that torque around the direction of insertion is only monitored when enabling insertion alignment in Step 4. For example, if the direction of insertion is set to +Fz and insertion alignment is enabled, the torque in the Tx, Ty, Tz directions will be monitored on whether its value is within this range. If insertion alignment is disabled, only torque in the Tx and Ty directions will be monitored. Torque in the Tz direction will not be monitored.</p> <p>The following diagram provides a visual representation.</p>  <p>The lower this tolerance value, the stricter success conditions are for the operation. It is recommended that you increase the tolerance, and then adjust it back based on actual operation results obtained.</p> <p>Minimum value: 1 [N·mm] Maximum value: 10,000 [N · mm] Default: 100 [N · mm]</p>

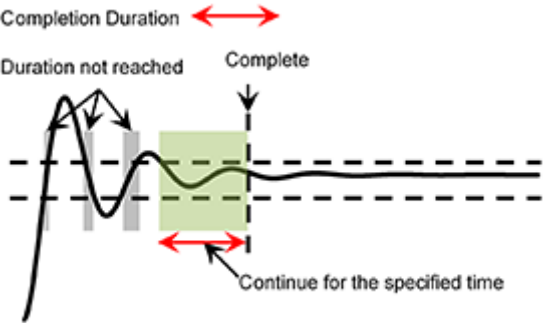
Item	Description, setting guide
<p>Completion Duration</p>	<p>Set the duration time which is used to determine whether the end conditions have satisfied. As shown below, if the specified condition continues for the time specified by Completion Duration, it is determined as the end conditions are satisfied.</p>  <p>Normally, set a short time close to "0". We recommend setting the time according to the actual result. Minimum value: 0.0 [sec] Maximum value: 10 [sec] Default: 0.1 [sec]</p>
<p>[Cancel] button</p>	<p>Cancels a new Insert sequence creation. Click it to end a sequence wizard.</p>
<p>[Back] button</p>	<p>Returns to the previous Step.</p>
<p>[Next] button</p>	<p>Proceeds to the next Step.</p>
<p>[Finish] button</p>	<p>You cannot click this button.</p>

Step 9. Set the timeout for the operation

Set the time-out for the operation. It is recommended that you set a longer time than the minimum required time.

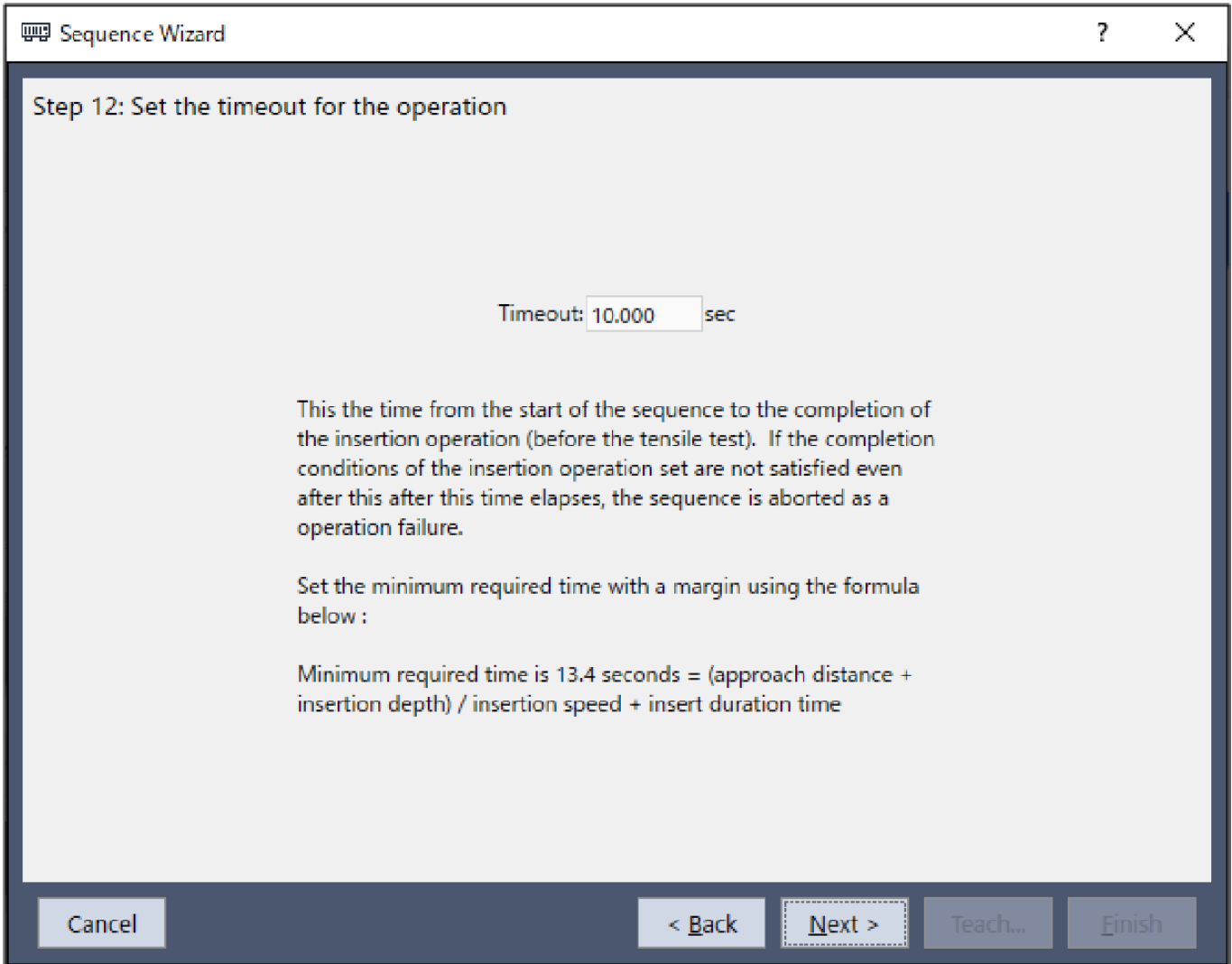

Item	Description, setting guide
Timeout	<p>Set the time-out duration. The time-out set is the insert operation execution time. If the insert operation fails to meet the end conditions set in Step 8 even when the timeout elapses, the insert operation will be aborted in failure.</p> <p>The minimum required time-out duration appears in the wizard. This is the minimum time required to complete the insert operation. As such, set the time-out duration to a longer time than the minimum required time shown. The minimum required time is determined based on the approach distance, insert depth, insertion speed, and time required to determine success set in Steps 5, 6, and 8, respectively.</p> <p>Minimum value: 0.1 [sec] Maximum value: 60 [sec] Default: 10.0 [sec]</p>
[Cancel] button	<p>Cancels a new Insert sequence creation. Click it to end a sequence wizard.</p>
[Back] button	<p>Returns to the previous Step.</p>
[Next] button	<p>When the tensile test is disabled in Step 4, you can proceed to the Change Summary screen. When you open from the new sequence creation screen, you can proceed to the Finish screen.</p>
	<p>When the tensile test is enabled in Step 4, you can proceed to the next Step.</p>

Item	Description, setting guide
[Finish] button	You cannot click this button.

Step 10. Set tensile test force, range, and duration

Set the end conditions for the tensile test. This setting screen is displayed when the tensile test is enabled in Step 4.

Step 13: Set tensile test force, range, and duration

Set the test force, effective range and duration of the tensile test (-Fz) according to the part

1. Test Force: N

2. Effective Range: N

3. Completion Duration: sec

Buttons: Cancel, < Back, Next >, Teach..., Finish

Item	Description, setting guide
Test Force	Set a test force applied in the direction of the tensile test shown in the wizard. Set a test force according to the part in use.
	When the tensile test direction is in the positive direction: Minimum value: -50.0 [N] Maximum value: 0.0 [N] Default: -5.0 [N]
	When the direction of insertion is in the negative direction: Minimum value: 0.0 [N] Maximum value: 50.0 [N] Default: 5.0 [N]

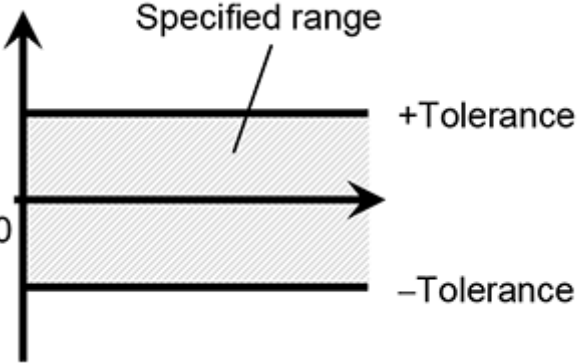
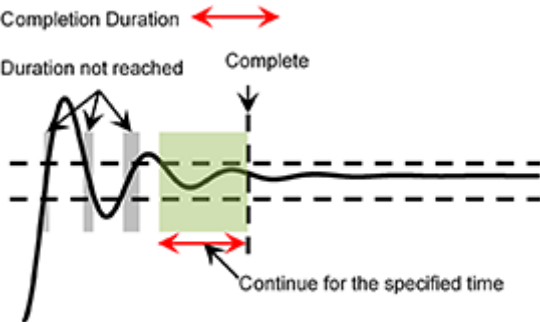
Item	Description, setting guide
Effective Range	<p>Range of the tensile test direction of the end conditions related to force. Set a range of the end conditions. This monitors whether the force in the direction indicated either by the Fx, Fy, or Fz tensile test direction is within the +/- effective range. For example, if the tensile test direction is indicated by -Fz, the force in the -Fz direction will be monitored on whether its value is within this range. The following diagram provides a visual representation.</p>  <p>The diagram shows a vertical axis with an upward arrow and a horizontal axis with a rightward arrow. The origin is labeled '0'. Two horizontal lines are drawn: the upper one is labeled '+Tolerance' and the lower one is labeled '-Tolerance'. The rectangular area between these two lines is shaded with diagonal lines and labeled 'Specified range' with a pointer line.</p> <p>The lower this tolerance value, the stricter success conditions are for the operation. It is recommended that you increase the tolerance, and then adjust it back based on actual operation results obtained. Minimum value: 0.1 [N] Maximum value: 10 [N] Default: 1.0 [N]</p>
Completion Duration	<p>Set the duration time which is used to determine whether the end conditions have satisfied. As shown below, if the specified condition continues for the time specified by Completion Duration, it is determined as the end conditions are satisfied.</p>  <p>The diagram shows a fluctuating signal line on a coordinate system. A horizontal dashed line represents a threshold. A red double-headed arrow at the top is labeled 'Completion Duration'. A green shaded area under the signal line, starting from a vertical dashed line and ending at another vertical dashed line, is labeled 'Continue for the specified time'. The area before the start of the green box is labeled 'Duration not reached' and the area after the end of the green box is labeled 'Complete'.</p> <p>Normally, set a short time close to "0". It is recommended that you set this duration based on actual operation results. Minimum value: 0.0 [sec] Maximum value: 10 [sec] Default: 0.1 [sec]</p>
[Cancel] button	<p>Cancels a new Insert sequence creation. Click it to end a sequence wizard.</p>
[Back] button	<p>Returns to the previous Step.</p>
[Next] button	<p>Proceeds to the next Step.</p>
[Finish] button	<p>You cannot click this button.</p>

Step 11. Set the clearance for the tensile test

Set the clearance for the tensile test. This setting screen is displayed when the tensile test is enabled in Step 4.

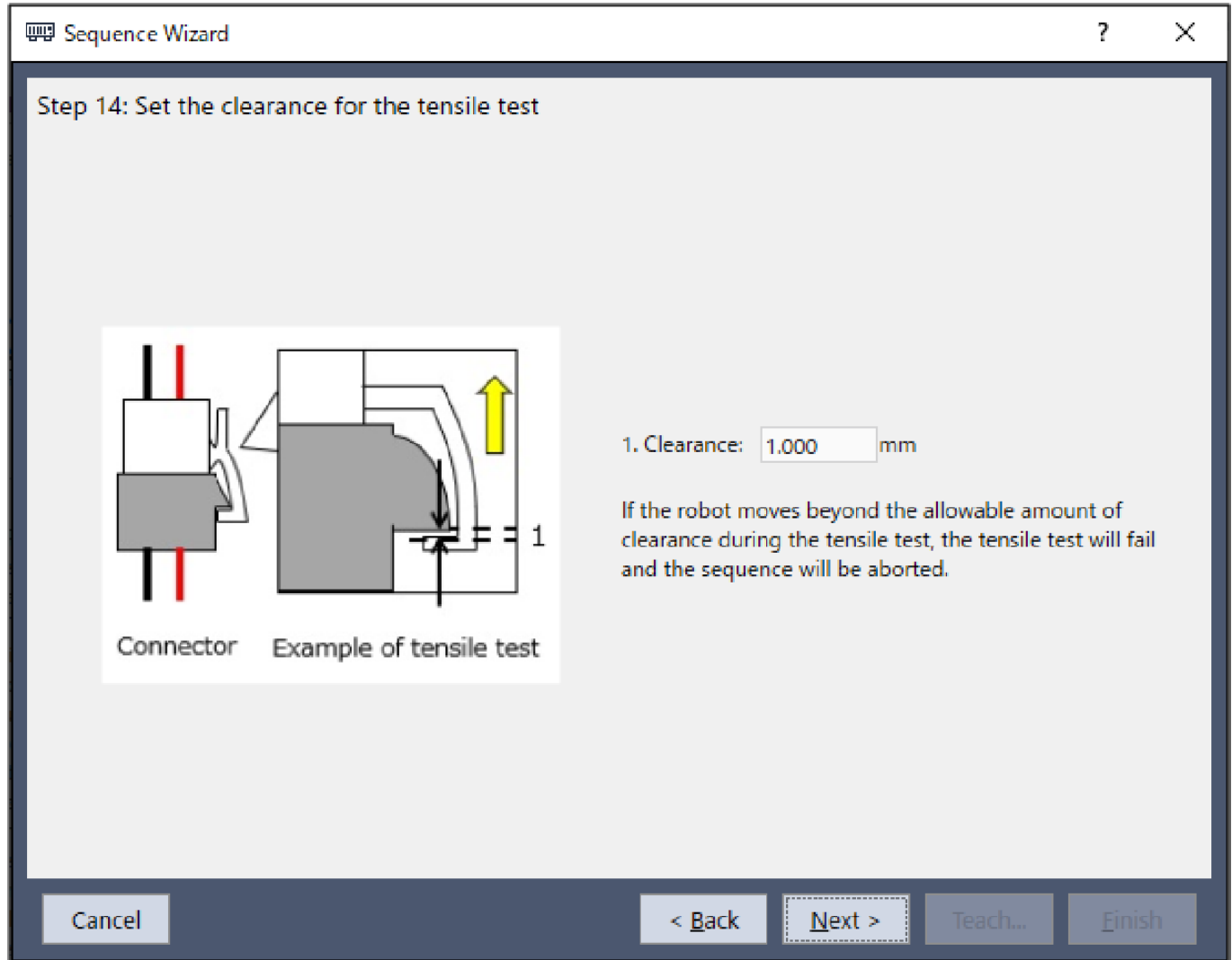

Item	Description, settings guide
Clearance	Sets the clearance between workpieces that occurs when the workpieces are pulled. When performing a tensile test, if the robot moves the allowable amount of clearance set in the Step 10 tensile test direction display or more, the TensileTest object will fail and the will be aborted. Minimum value: 0.1 [mm] Maximum value: 10 [mm] Default: 1[mm]
[Cancel] button	Cancels a new Insert sequence creation. Click it to end a sequence wizard.
[Back] button	Returns to the previous Step.
[Next] button	Proceeds to the next Step.
[Finish] button	You cannot click this button.

Step 12. Set the timeout for the operation

Set the time-out for the tensile test.

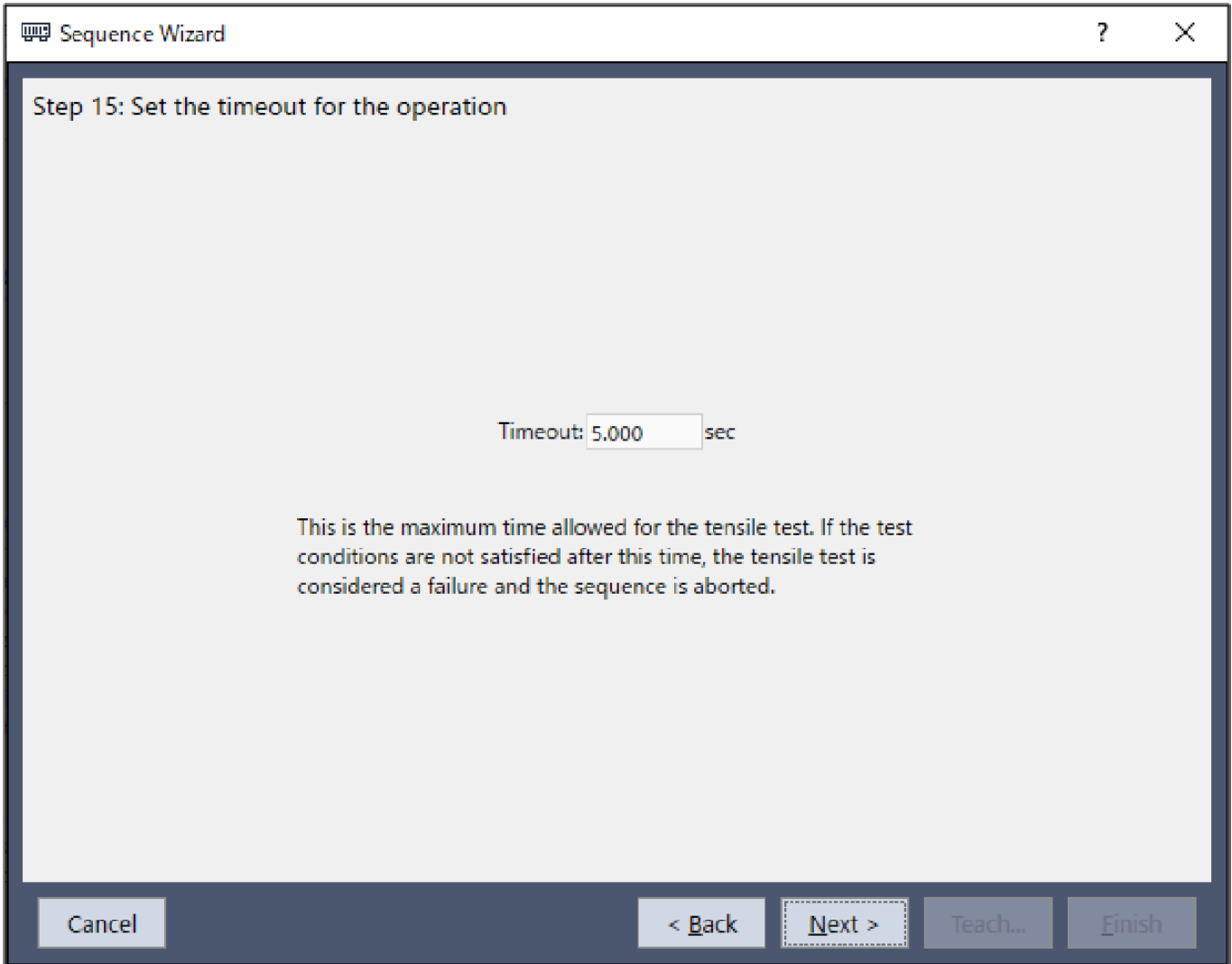

Item	Description, setting guide
Timeout	Set the time-out duration. The time-out set is the tensile test execution time. If the tensile test does not meet the completion condition set in Step 10 even after the set time-out has passed, the test is considered a failure and the Insert sequence is aborted. Minimum value: 0.1 [sec] Maximum value: 60 [sec] Default: 5.0 [sec]
[Cancel] button	Cancels a new Insert sequence creation. Click it to end a sequence wizard.
[Back] button	Returns to the previous Step.
[Next] button	Proceeds to the Change Summary screen. When you open from the new sequence creation screen, you can proceed to the Finish screen.
[Finish] button	You cannot click this button.

Step 13. Change Summary

You can see the list of properties that have been changed in the wizard.

This is displayed when you edit the created Insert sequence in the Sequence Wizard. It is not displayed when creating a new one.

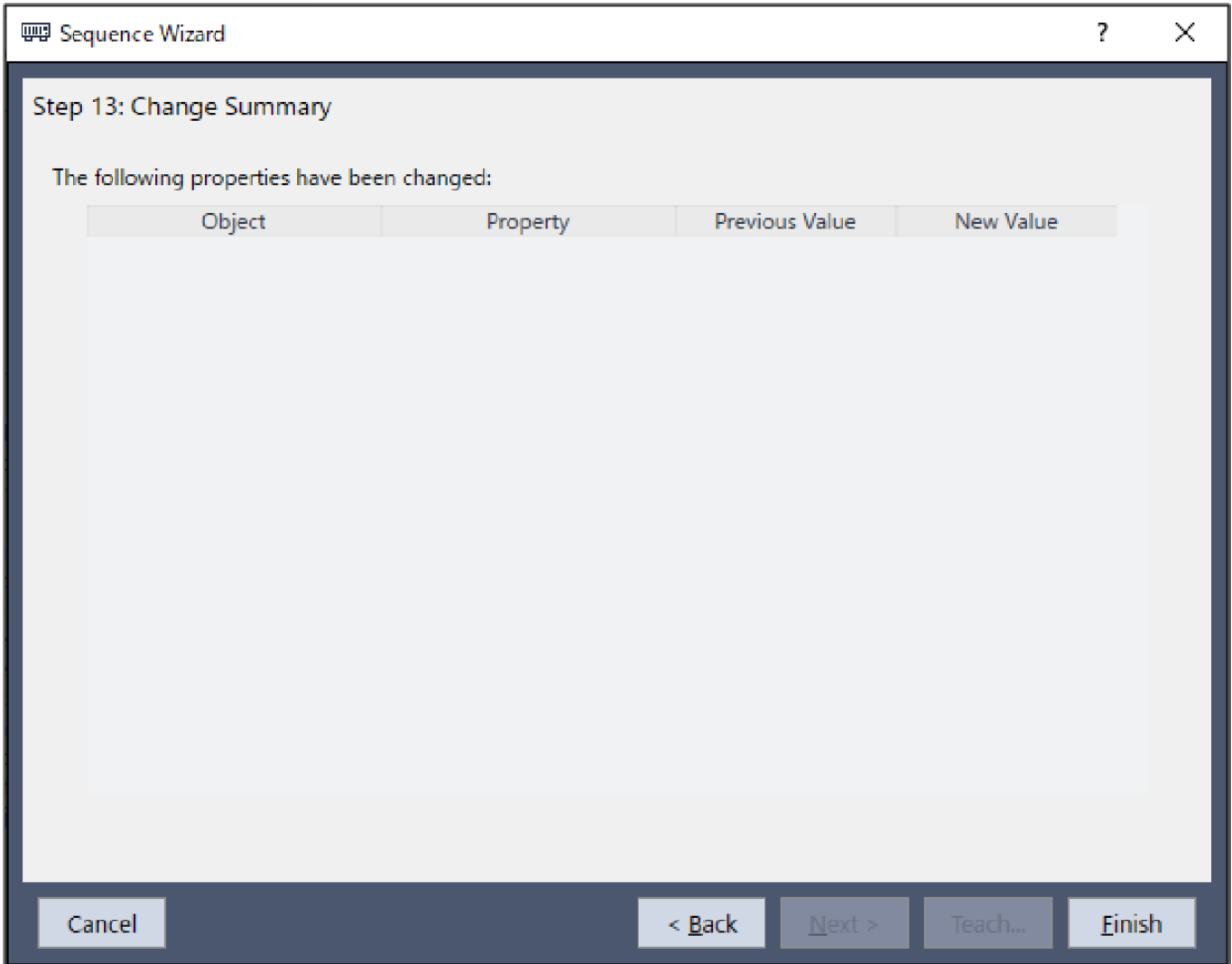

Item	Description
Objects Properties	Shows which properties of which sequence or object have been changed as a result of changing settings in the wizard.
Previous Value New Value	Shows how the properties have been changed as a result of changing the settings in the wizard.
[Cancel] button	Cancels a new Insert sequence creation. Click it to end a sequence wizard.
[Back] button	Returns to Step 9 when the tensile test in Step 4 is disabled.
	Returns to Step 12 when the tensile test in Step 4 is enabled.
[Next] button	You cannot click this button.
[Finish] button	Completes changing the Insert sequence.
	Completes changing the Insert sequence with the entered contents.

Finish: Insert Sequence Created

This is the completion screen for the set sequence.

You can check the created sequence name and type. The screen is displayed when opening from the new sequence creation screen.

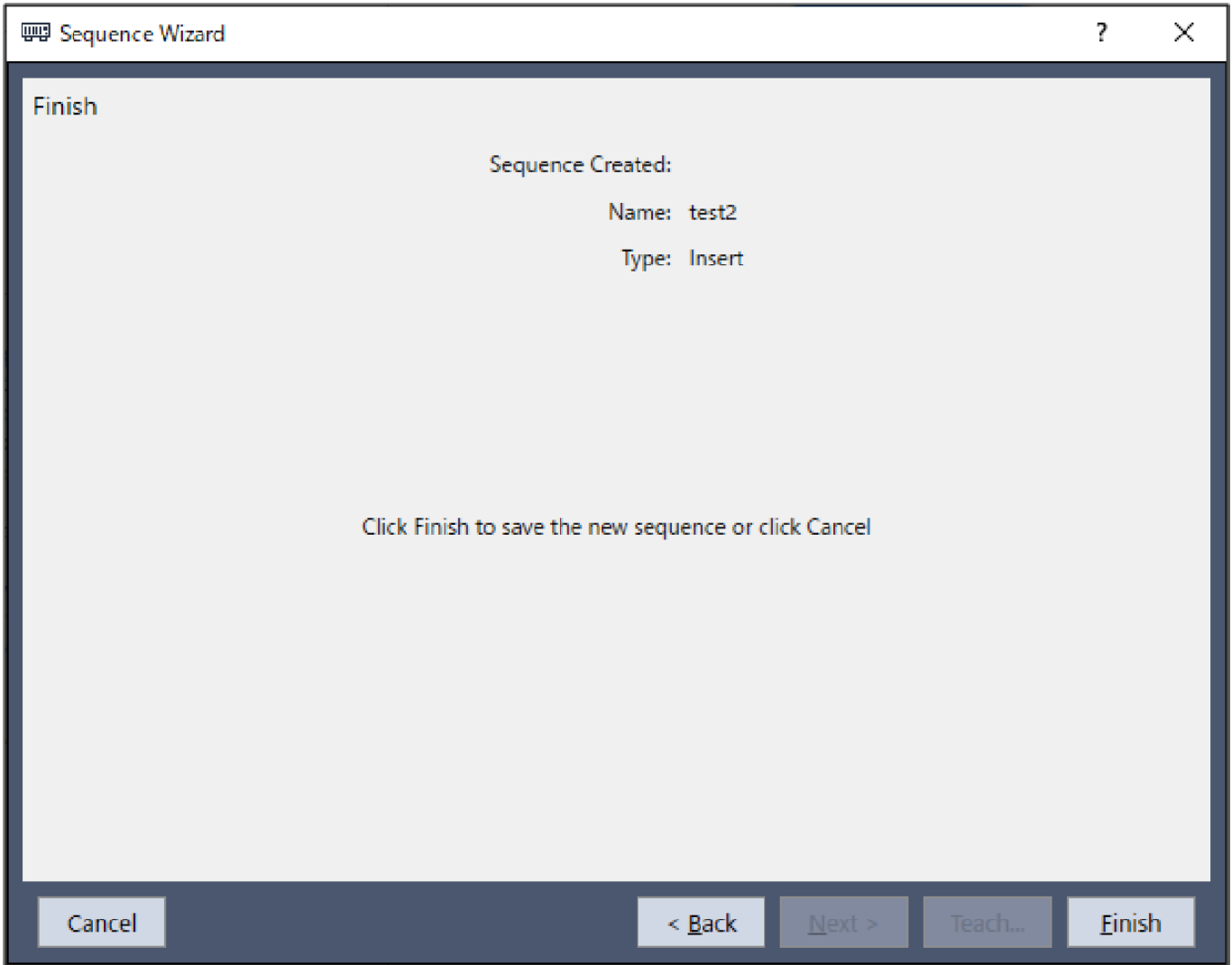

Item	Description
Name	The sequence name set in Step 1. General. Refer to the next section for setting the sequence name. Software [Force Guidance] [Tools] menu - Create a new force guide sequence - Sequence Wizard: Create a new system force guide sequence - Step1: General
Type	The sequence type set in Step 3. Select system sequence. Refer to the next section for selecting the sequence type. Software [Force Guidance] [Tools] menu Create a new force guide sequence - Sequence Wizard: Create a new system force guide sequence -Step 3: Select system sequence
[Cancel] button	Cancels a new Insert sequence creation. Click it to end a sequence wizard.
[Back] button	Returns to Step 9 when the tensile test in Step 4 is disabled.
	Returns to Step 12 when the tensile test in Step 4 is enabled.
[Next] button	You cannot click this button.

Item	Description
[Finish] button	Completes creating a new Insert sequence. Completes creating a new Insert sequence with the entered contents.

4.4.6.2 Insert Sequence

The following describes properties of the Insert sequence and its setting steps.

4.4.6.2.1 Property setting guidelines for Insert sequence

General setting steps and setting methods for each property are as follows:

Step 1. Set basic information

Set properties related to the basic information.

Properties	Description
Name	Force guide sequence name. Set a particular name.
Index	Particular number for a force guide sequence. It is assigned automatically. You cannot set this.
Description	Descriptions for force guide sequence. Describe the tasks. Set a character string.
Version	A compatible version of the sequence. The sequence operates with the specified version function.
RobotNumber	Robot number to execute a force guide sequence. Set a robot number to be executed.
RobotType	Robot type which is set by RobotNumber. You cannot set this.
AutoStepID	Set whether to set StepID of force guide object automatically. StepID is an ID which is recorded in the log data. It helps you to understand which log data support a process. True: Normal False: When you want to set StepID manually.
PointFile	Set a point file which will be used in a force guide sequence. An error occurs when the specified point file is not loaded at the start. This is a property for preventing a wrong operation. If a point file is not set, any point file whichever loads is executed.
RobotTool	Set a tool number which will be used in a force guide sequence. An error occurs when the set tool number is not selected at the start. This is a property for preventing a wrong operation.

Step 2. Set for correction of sensor value

Set properties (ResetSensor, MPNumber) related to sensor value correction.

Properties	Description, setting guide
ResetSensor	Set whether to reset the Force Sensor when executing a force guide object other than Decision object and SPELFunc object for the first time during the force guide sequence execution.
	True: When a workpiece has not been in contact with anything at the start of the force guide sequence. (Normally, it is in the non-contact state at the start of the force guide sequence.)
	False : Used in rare cases, such as when a force guide sequence is executed, and then another force guide sequence is executed with the contact state unchanged.
MPNumber	Specify the number of Mass Property Object which is used during the force guide sequence execution. Mass Property Object is a collection of properties using for gravity compensation.
	"0": When the orientations (U, V, W) do not change greatly during the force guide sequence execution.
	Created Mass Property number: When the orientations change greatly during the force guide sequence execution.
	For more details on Mass Property, refer to the following section. Software Gravity Compensation

Step 3. Set for coordinate system of force control function

Set properties (ForceOrient, RobotLocal, RotationCenterType, RotationCenterTLX, RotationCenterTLY, RotationCenterTLZ) related to a coordinate system of the force control function.

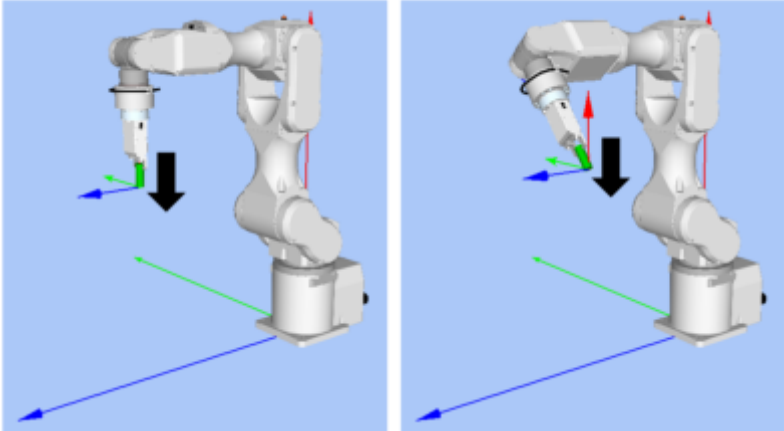
Properties	Description, setting guide
ForceOrient	Set a coordinate system direction which executes the force control function.
	<p>Base, Local:</p> <p>When you want to execute the force control function to a defined direction as viewed from outside, such as pressing to vertical-downward, even if the start orientation of force guide sequence is changed.</p> <p>Local is specified when a defined direction is different from the axis of the Base coordinate system. The following is an example to set Base.</p> <p>When pressing to -Z direction, the robot always presses to the vertical-downward (-Z direction in Base coordinate system) even the orientation of end effector changed. (Black arrow is a direction of the robot motion.)</p> 

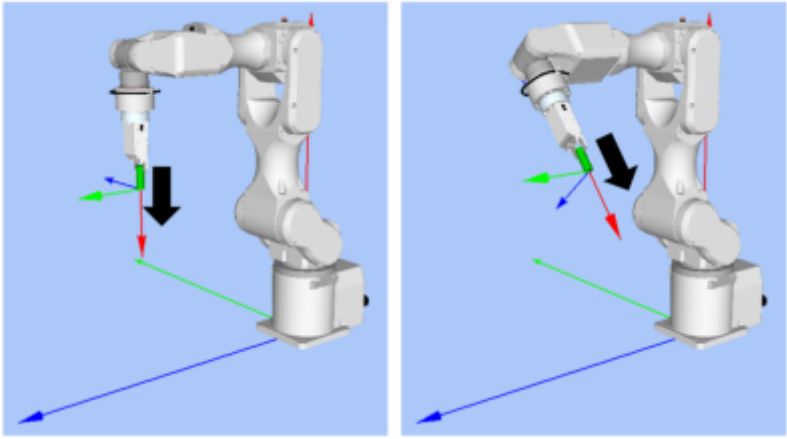
Properties	Description, setting guide
	<p>Tool:</p> <p>When you want to execute the force control function depending on an orientation at the start. The following is an example to set Tool.</p> <p>When pressing to +Z direction, the pressing direction changes depending on the orientation of end effector at the start.</p> 
RobotLocal	Set Local coordinate system number which is used when ForceOrient is Local.
RotationCenterTLX RotationCenterTLY RotationCenterTLZ	Set an offset amount to each axis from Tool coordinate system to the rotation center.

You can check the settings related to the coordinate system of the force control function by using a simulator. However, if no force guide object is aligned in the force guide sequence, check the setting after adding the force guide objects. For details on how to check by using simulator, refer to the following manual. "Epson RC+ 8.0 User's Guide: - Simulator - Description of Functions"

Step 4. Set the maximum speed and the maximum acceleration

Set properties (LimitAccelS, LimitAccelR, LimitSpeedS, LimitSpeedR) related to the maximum speed and the maximum acceleration.

Properties	Description, setting guide
LimitSpeedS LimitSpeedR	<p>Set a maximum speed during the execution of the force guide sequence.</p> <p>LimitSpeedS: Maximum translational speed LimitSpeedR: Maximum rotational rotation speed</p> <p>In the force control function, the speed changes depending on the how the force is applied. It is controlled not to exceed LimitSpeedS and LimitSpeedR.</p>
LimitAccelS LimitAccelR	<p>Set a maximum acceleration during the execution of the force guide sequence.</p> <p>LimitAccelS: Maximum translational acceleration LimitAccelR: Maximum rotational rotation acceleration</p> <p>In the force control function, the acceleration changes depending on how the force is applied. It is controlled not to exceed LimitAccelS and LimitAccelR.</p> <p>If the value is small, reaction when the force is applied will be slow and the robot will bounce largely. Set a larger value when the robot bounces. When the robot vibrates, set the value smaller.</p>

Step 5. Set conditions about recording

Set properties (LogRobotLocal, LogFileEnabled, LogFileAutoName, LogFileNameVar, LogFileMaxTime, LogFileInterval) related to recording.

Properties	Description, setting guide
LogRobotLocal	Set a Local coordinate system number which will be a reference of the recording robot position. Log data related to positions is recorded as positions of the specified Local coordinate system.
	Base: Normal
	Local coordinate system number: When you want to record as a position in the specified Local coordinate system
LogFileEnabled	Set whether to save the log data which is executing a force guide sequence to a file.
	False: It is not saved in a file. You can check the log data on the graph of force guide window when executing.
LogFileAutoName	Set whether to set the log data file name automatically.
	True : When Automatically set Is generated by the force guide sequence name and the start time. "Force guide sequence name _yyyymmdd_hh:mm:ss:ms"
	False: When specifying a name
LogFileNameVar	Set a global variable which indicates a log data file name when LogFileAutoName is False.
LogFileInterval	Set a sampling interval of log data when creating files.
LogFileMaxTime	Set a maximum time of log data when creating files.

4.4.6.2.2 Details on properties of Insert sequence

- Name Property**
 This property sets a particular name that is assigned to force guide sequences.
 You cannot create the force guide sequence with the same name.
 You can change the name. Set up 16 characters at the maximum. Please use alphanumeric characters and underscores [_].
 Note: The initial character cannot be a numeric character.

- Index Property**
 This property displays a number of force guide sequence. This property is set and updated automatically. It cannot be edited.

	Value
Minimum Value	1
Maximum value	32

- Description Property**
 This property sets a description of force guide sequence. You can set the character string up to 255 characters.
- Version Property**
 For system sequence, the version 7.5.1 supports. It cannot be changed.
- RobotNumber Property**
 This property sets a robot number that uses a force guide sequence.
 An error occurs when executing the force guide sequence by the robot which is not specified.

Value	Description
1 to 16	Robot number to use a force guide sequence.

Default: Robot number specified in the sequence wizard.

▪ RobotType Property

This property is the robot types that use a force guide sequence.

It is automatically set from the robot number specified by RobotNumber. It cannot be edited.

▪ AutoStepID Property

This property sets an automatic assignment of StepID in force guide object execution.

When assigning a StepID automatically, it is set to the force guide sequence number*100 + the force guide object number.

StepID is recorded to files that the force and the position during the force guide sequence execution is recorded. It is used to determine which interval corresponds to which force guide object.

Value	Description
True	Set StepID automatically.
False	Set a property value of StepID of each force guide object.

Default: True

▪ ResetSensor Property

This property sets whether to reset a Force Sensor when starting force guide object other than Decision object and SPELFunc object for the first time in the force guide sequence.

Value	Description
True	Reset the Force Sensor when starting a force guide object other than Decision object and SPELFunc object.
False	Force Sensor is not reset.

Default: True

▪ MPNumber Property

This property sets the number of Mass Property Object which is used during the force guide sequence execution.

Mass Property Object is a collection of properties using for gravity compensation. You need to define Mass Property Object in advance. If an angle will change largely during the execution of the force guide sequence, make sure to specify the proper Mass Property Object.

Value	Description
0	Turn OFF the gravity compensation.
1 to 15	Use the specified Mass Property.

Default: 0

▪ PointFile Property

This property sets the point file name that is used during the force guide sequence execution.

If the point file which is not specified by this property is loaded when the force guide sequence starts, an error occurs. This is a property for preventing a wrong operation.

Value	Description
None	Not specified (Any point file whichever loads can be executed without checking it.)
Point file name	An error occurs when the specified point file is not loaded.

Default: None

▪ RobotTool Property

This property sets the Tool coordinate system number that is used during the force guide sequence execution.

If the Tool coordinate system number which is not specified by this property is selected when the force guide sequence starts, an error occurs. This is a property for preventing a wrong operation.

Value	Description
0 to 15	An error occurs when the set tool number is not selected.

Default: 0

■ ForceOrient Property

This property specifies the direction of coordinate system that uses the force control functions during the force guide sequence execution.

You can select from Base, Local, and Tool. Specify the coordinate system that the direction to insert.

If Base or Local is specified, the direction to insert will not be changed even if the robot orientation changes.

If Tool is specified, the direction to insert changes since the direction of Tool coordinate system changes when the robot orientation is changed.

Value	Description
Base	The direction of the coordinate system to which the force control function is applied is the Base coordinate system
Local	The direction of the coordinate system to which the force control function is applied is the Local coordinate system
Tool	The direction of the coordinate system to which the force control function is applied is the Tool coordinate system

Default: Tool

■ RobotLocal Property

This property specifies the Local coordinate system number of coordinate system that applies the force control functions during the force guide sequence execution.

It is used when ForceOrient property is Local.

Value	Description
0 (Base)	Use the Local 0 coordinate system (Base coordinate system). It is the same as when specifying Base in ForceOrient.
1 to 15	Use the Local coordinate system of the specified number.

Default: 0 (Base)

■ RotationCenterTLX Property

This property sets a distance in X direction from Tool coordinate system to the rotation center of the force control function.

It is the X direction of the Tool coordinate system which is selected in RobotTool.

	Value (Unit: [mm])
Minimum Value	-2000
Maximum value	2000

Default: 0

■ RotationCenterTLY Property

This property sets a distance in Y direction from Tool coordinate system to the rotation center of the force control function.

It is the Y direction of the Tool coordinate system which is selected in RobotTool.

	Value (Unit: [mm])
Minimum Value	-2000

Maximum value	2000
---------------	------

Default: 0

▪ **RotationCenterTLZ Property**

This property sets a distance in Z direction from Tool coordinate system to the rotation center of the force control function. It is the Z direction of the Tool coordinate system which is selected in RobotTool.

	Value (Unit: [mm])
Minimum Value	-2000
Maximum value	2000

Default: 0

▪ **LimitSpeedS Property**

This property sets the maximum speed during the execution of force guide sequence. The robot motion will change depending on applied force and torque when executing the force guide sequence since it is adjusted by the force control functions. However, it is restricted by the speed which is specified by this property.

	Value (unit: [mm/sec])
Minimum Value	0.1
Maximum value	250

Default: 50

▪ **LimitSpeedR Property**

This property sets the maximum rotation speed during the execution of force guide sequence. The robot motion will change depending on applied force and torque when executing the force guide sequence since it is adjusted by the force control functions. However, it is restricted by the rotation speed which is specified by this property.

	Value (unit: [deg/sec])
Minimum Value	0.1
Maximum value	180

Default: 25

▪ **LimitAccelS Property**

This property sets the maximum acceleration during the execution of force guide sequence. The robot motion will change depending on applied force and torque when executing the force guide sequence since it is adjusted by the force control functions. However, it is restricted by the acceleration which is specified by this property.

	Value (unit: [mm/sec ²])
Minimum Value	0.1
Maximum value	25000

Default: 200

▪ **LimitAccelR Property**

This property sets the maximum rotation acceleration during the execution of force guide sequence. The robot motion will change depending on applied force and torque when executing the force guide sequence since it is adjusted by the force control functions. However, it is restricted by the rotation acceleration which is specified by this property.

	Value (unit: deg/sec ²)
Minimum Value	0.1

	Value (unit: deg/sec ²)
Maximum value	5000

Default: 100

▪ LogRobotLocal Property

For the positional orientation of the robot that is recorded during the force guide sequence execution, set a reference local coordinate system number.

The position of the robot is recorded as that of Tool coordinate system as viewed from the Local coordinate system specified by this property.

Value	Description
0 (Base)	Use the Local 0 coordinate system (Base coordinate system).
1 to 15	Use the Local coordinate system of the specified number.

Default: 0 (Base)

▪ LogFileEnabled Property

This property sets whether to save the force, torque, and the position of the robot during the force guide sequence execution in files.

When specifying True, value will be displayed in the graph on the monitor and saved in the files simultaneously.

When specifying False, value will be displayed in the graph on the monitor. However, the value is not saved in the files.

Value	Description
True	Save the log data in a file.
False	The log data is not saved in a file.

Default: False

▪ LogFileAutoName Property

This property sets whether to automatically set the file name that records force, torque, and the position of the robot during the force guide sequence execution.

When specifying True, the file name is automatically set with the force guide sequence name + start time.

Force guide sequence name_yyyymmdd_hhmmssfff.csv

When specifying False, add ".csv" to the string in variables which is specified in LogFileNameVar to make it a file name.

Value	Description
True	Set the name of the log data file automatically.
False	Set a log data file name to the one which is specified by LogFileNameVar.

Default: True

▪ LogFileNameVar Property

This property sets a global string variable that saves a file name which records force, torque, and the position of the robot during the force guide sequence execution.

It is used when False is specified in LogFileAutoName. Add ".csv" to the string in variables and set it as a file name.

Value	Description
None	Not specified (automatically set)
Variable name	Value of the specified global string variable will be a file name. Only a string variable can be specified.

Default: None

- LogFileInterval Property

This property sets the sampling period for the files that record force, torque, and the position of the robot during the force guide sequence execution.

	Value (unit: [sec])
Minimum Value	0.002
Maximum value	1

Default: 0.2

- LogFileMaxTime Property

This property sets the maximum recording time for the files that record force, torque, and the position of the robot during the force guide sequence execution.

If the specified recording time is shorter than the execution time of the force guide sequence, nothing is recorded in the file after the recording time is passed. note that

	Value (unit: [sec])
Minimum Value	60
Maximum value	600

Default: 60

4.4.6.2.3 Details on results of Insert sequence

- EndStatus Result

It is a result of the execution.

Result will be succeeded when the force guide sequences are executed to the end and the final force guide object is succeeded or AbortSeqOnFail property of the final force guide object is False.

Value	Description
Passed	Force guide sequence is succeeded.
Failed	Force guide sequence is failed.
NoExec	Force guide sequence is not executed.
Aborted	Aborted during the execution of force guide sequence.

- FailedStatus Result

It is the reason why the force guide sequence failed.

It is the reason for failure when the result of executing an object with AbortSeqOnFail set to True.

Value	Description
OK	Force guide sequence is succeeded.
GeneralObjectFailed	General object is failed.
ForceConditionFailed	Failed due to the force is out of the range of success conditions.
PosConditionFailed	Failed due to the position is out of the range of success conditions.
Overrun	Failed due to overrun.
Jammed	The force is in the range of the success conditions, but failed due to the position is out of the success conditions.

- **Time Result**
This is the time required for execution.
Unit: [sec]
- **LastExecObject Result**
Force guide object name which is executed at the end.
- **EndForces Result**
Force and torque when force guide sequence ends. Acquire values of Fx, Fy, Fz, Tx, Ty, and Tz.
Unit: Fx, Fy, Fz [N] / Tx, Ty, Tz [N · mm]
- **PeakForces Result**
Peak values of force and torque during the force guide object execution. The peak value is a value which absolute value is the largest. Acquire values of Fx, Fy, Fz, Tx, Ty, and Tz.
Unit: Fx, Fy, Fz [N] / Tx, Ty, Tz [N · mm]

4.4.6.3 Insert Object

The Insert object is a force guide object used to move the robot by pressing in a specified direction with a specified amount of force while simultaneously following another direction.

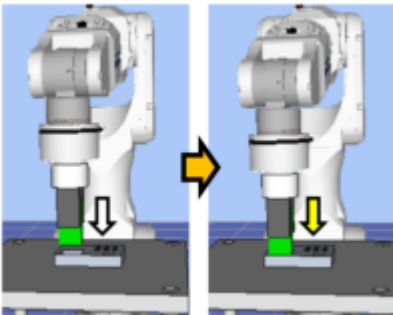

The diagram above provides a visual representation of an Insert sequence. Executed from a non-contact state, this sequence presses the robot in the direction depicted by the white arrow. From the point of contact, the robot continues to apply a set amount of force in the direction shown by the yellow arrow.

The Insert object succeeds or fails when the end conditions are met within the specified time. The Insert object can apply end conditions related to force and position.

Each end condition is always applied.

When all the success conditions for each end condition are met: The Insert object execution ends. The execution is determined as succeeded and proceed to the next force guide object.

When at least one of the failure conditions for each end condition is met: The Insert object execution ends. The execution is determined as failed and abort the force guide sequence.

End condition	Success condition
End conditions related to force	During the specified Timeout period, keep all of the following conditions satisfied for the length of the HoldTimeThresh period: In Fx, Fy, or Fz, the axis which is specified in InsertOrient should be within the range of InsertForce - InsertCheckToIF to InsertForce + InsertCheckToIF
	When ForceCheckMode is PressFollow: In Fx, Fy, Fz, The force in the axis specified in FollowOrient Should be within the range of -FollowCheckToIF to +FollowCheckToIF

End condition	Success condition
	When ForceCheckMode is PressFollow: In Tx, Ty, Tz, The axis torque which is specified in FollowOrient Should be within the range of -FollowCheckToIT to +FollowCheckToIT
End conditions related to position	Satisfy the following within the specified time of Timeout. The moving distance from the force guide object start point in the axial direction specified in InsertOrient is within the range of ApproachDist + InsertDepth + DistCheckTol

End condition	Failure condition
End conditions related to position	Satisfy the following within the specified time of Timeout. The moving distance from the force guide object start point in the axial direction specified in InsertOrient is exceeds the range of ApproachDist + InsertDepth - DistCheckTol to ApproachDist + InsertDepth + DistCheckTol

4.4.6.3.1 Property guideline for Insert object

Step 1. Set basic information

Set properties (Name, Description, StepID, AbortSeqOnFail) related to the basic information.

Properties	Description, setting guide
Name	This property sets names of force guide objects. Set a particular name.
Description	This property sets descriptions about force guide objects. Describe the operations. Set a character string.
StepID	StepID during the force guide object execution. Set an ID. StepID is an ID which is recorded in the log data. It helps you to understand which log data support a process. It is applied when AutoStepID of the force guide sequence is False.
AbortSeqOnFail	Set whether to abort or continue the force guide sequence when the force guide object fails.
	True : Normal End a force guide sequence.
	False : Cases where the force guide sequence contains recovery operations in case of failure; cases where the sequence will be able to continue even in the event of a failure.

Step 2. Set a movement motion

Set properties (AccelS, SpeedS) related to movements.

Properties	Description, setting guide
AccelS	Set an acceleration of the movement. AccelS: Translational Acceleration Actual acceleration is adjusted by the force control functions.

Properties	Description, setting guide
SpeedS	Set the translational velocity of the movement. SpeedS: Translational Speed Actual speed is adjusted by the force control functions.

Step 3. Set a destination point

Set properties (ApproachDist, InsertDepth, DecelStartRaio) related to trajectories to move.

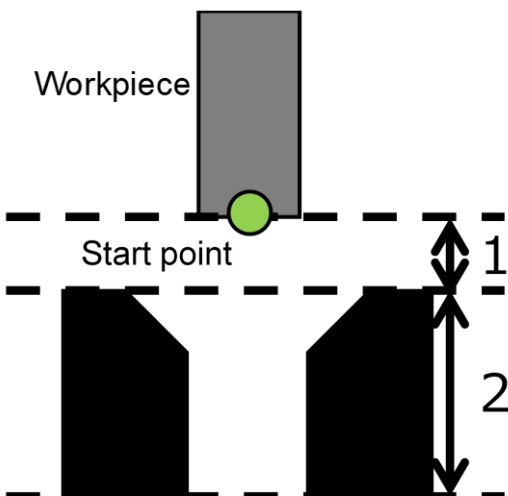
Properties	Description, setting guide
ApproachDist	<p>Set an approach distance from the start point of the force guide object to the opening of the insertion hole.</p> <p>The approach distance is distance 1 depicted in the diagram below, which is the distance between the end point of the gripped workpiece at the start point of the force guide object indicated by the green dot, and the opening of the hole.</p>  <p>Teach the robot a start point of the motion that shortens the approach distance as much as possible. As the force control function is slower than position control, longer approach distances will result in longer cycle times.</p>
InsertDepth	<p>Set an insert depth of the hole.</p> <p>The InsertDepth is length 2 depicted in the ApproachDist diagram.</p>
DecelStartRatio	<p>Set a distance ratio to begin decelerating motion of the force guide object.</p> <p>The force guide object simultaneously executes position control and force control functions to travel from the start point of the motion for the moving distance described below. After this distance is covered, the force guide object will begin decelerating, and will operate by the force control function alone.</p> <p>$ApproachDist + InsertDepth * DecelStartRatio / 100$</p> <p>Reducing the DecelStartRatio will reduce the distance from the start point of the force guide object to the point at which the force guide object begins decelerating. This will reduce the speed of contact between the workpiece and the hole bottom when the force guide object finishes executing, and will decrease the overshoot of the force. However, this will result in slower cycle times.</p> <p>Increasing the DecelStartRatio will lengthen the distance from the start point of the force guide object to the point at which the force guide object begins decelerating. This will increase the speed of contact between the workpiece and the hole bottom when the force guide object finishes executing, and will increase the overshoot of the force. This will result in quicker cycle times.</p>

Step 4. Set force control functions

Set properties (InsertOrient, InsertForce, InsertFirmnessF, FollowOrient, FollowFirmnessF, RotationFollowMode, FollowFirmnessT) related to the force control functions.

Properties	Description, setting guide
InsertOrient	<p>Set a direction to insert. The robot moves to the specified direction.</p>
InsertForce	<p>Set a force to insert in the insert direction. When InsertOrient is positive direction: Enter a negative value. When InsertOrient is negative direction: Enter a positive value. Set a proper value for your workpiece. If the value is too small, the robot may not operate.</p>
InsertFirmnessF	<p>Set the firmness of the force control functions in the insert direction.</p>
	<p>When setting a large value: The Force Control functions become stronger, but response to changes in force is slow.</p>
	<p>When setting a small value: The Force Control function will become weaker. Response to changes in force is fast; however, vibrations can easily occur.</p>
FollowOrient	<p>In addition to the InsertOrient direction, it is the direction to move and rotate while following. It is changed automatically according to InsertOrient and RotationFollowMode. However, the force display does not change depending on the RotationFollowMode setting because it always follows the direction of the force in the two translational directions not specified by InsertOrient. Read only. It cannot be edited. For example, when you specify +Fz or -Fz in InsertOrient and specify Tilt in RotationFollowMode, Fx and Fy not specified in InsertOrient, and Tx and Ty which rotate around Fx and Fy, become FollowOrient.</p>
FollowFirmnesF	<p>Set a firmness of the force control functions in translational direction except for inserting direction. When setting a large value: The force control function will become stronger. However, response to changes of the force is slow. When setting a small value: The force control function will become weaker. Response to changes of the force is fast, however, vibration is easy to occur.</p>

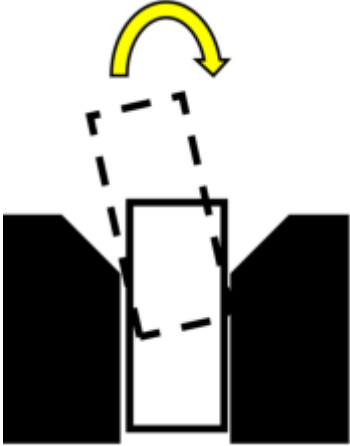
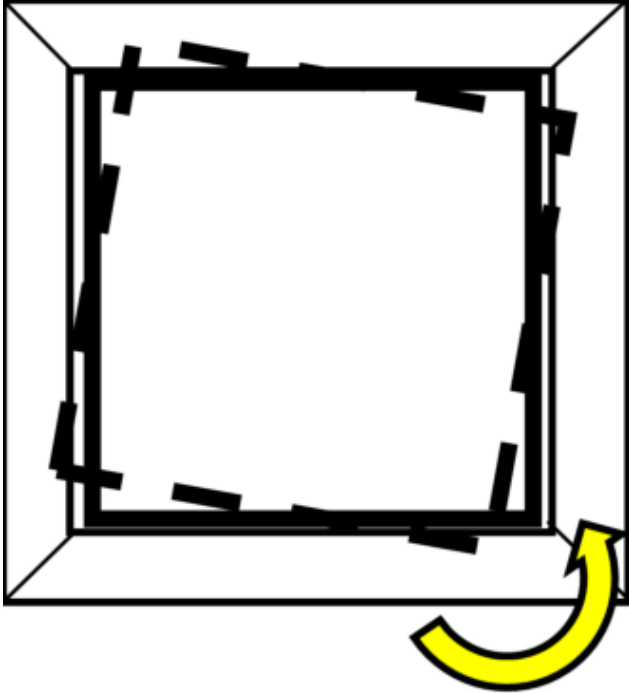
Properties	Description, setting guide
RotationFollowMode	Set a direction to enable the follow operation in the rotation direction.
	Disabled: Does not follow the rotation direction.
	Tilt: Follows the direction to match orientation. Follows the direction of the yellow arrow in the figure below. 
	Rotate: Follows the direction to match phases. Follows the direction of the yellow arrow in the figure below. 
FollowFirmnessT	Set a firmness of the force control functions in rotation direction.
	When setting a large value: The Force Control functions become stronger, but response to changes in force is slow.

Properties	Description, setting guide
	When setting a small value: The Force Control function will become weaker. Response to changes in force is fast; however, vibrations can easily occur.

Step 5. Set basic information for end conditions

Set property (Timeout) related to time-out.

Properties	Description, setting guide
Timeout	Set the time-out duration.
	When the end conditions are not set: Time-out period is the execution time.
	When the end conditions are set: Fails when the end conditions are not satisfied within the specified time.

Step 6. Set end conditions related to force

Set properties (ForceCheckEnabled, ForceCheckMode, ForceCheckPolarity, PressCheckToIF, PressCheckToIT, FollowCheckToIF, FollowCheckToIT, HoldTimeThresh) related to the end conditions of force.

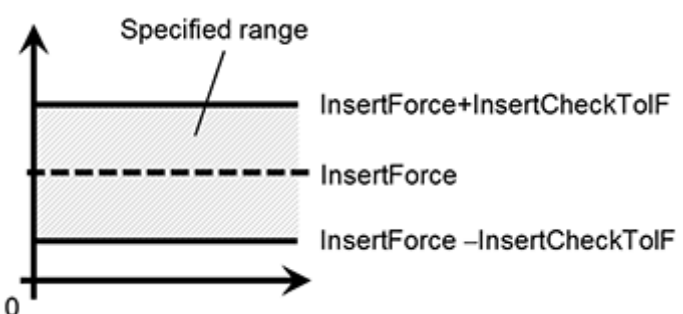
Properties	Description, setting guide
ForceCheckMode	Target direction of determination.
	Press : Only the pressing direction is evaluated. Directions (Press+, Press-) specified by ControlMode are evaluated.
	PressFollow : The pressing direction and follow direction are evaluated. Directions (Press+, Press-, Follow) specified by ControlMode is a target of determination.
InsertCheckToIF	<p>This property sets the pressing direction range of the end conditions related to force. Set a range of the end conditions. InsertCheckToIF is applied for Fx, Fy, and Fz. It monitors that the force of directions specified by InsertOrient of Fx, Fy, and Fz are within the range of InsertForce - InsertCheckToIF to InsertForce + InsertCheckToIF. The following is an image of InsertCheckToIF.</p> 

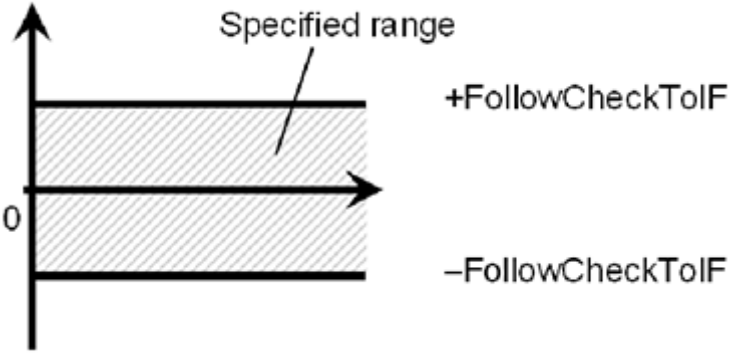
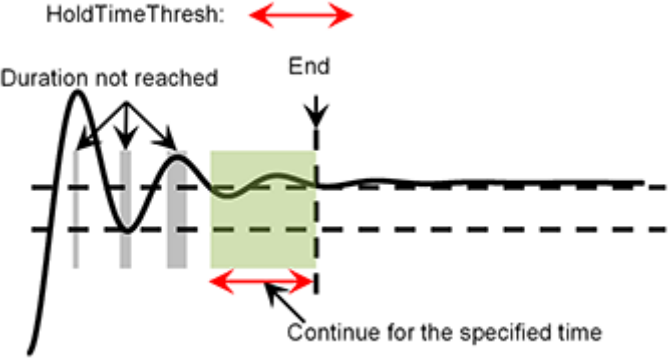
Properties	Description, setting guide
<p>FollowCheckToIF FollowCheckToIT</p>	<p>This property sets the range in the follow direction of the end conditions related to force. FollowCheckToIF is applied for Fx, Fy, and Fz, FollowCheckToIT is applied for Tx, Ty, and Tz It monitors that the force of directions specified by FollowOrient of Fx, Fy, and Fz are within the range of - FollowCheckToIF to + FollowCheckToIF. It monitors that the torque of the force directions specified by FollowOrient of Tx, Ty, and Tz is within the range of - FollowCheckToIT to + FollowCheckToIT. The following is an image of InsertCheckToIF.</p> 
<p>HoldTimeThresh</p>	<p>Set the duration time which is used to determine whether the end conditions have satisfied. As shown below, if the specified condition continues for the time specified by HoldTimeThresh, it is determined as the end conditions are satisfied.</p>  <p>Normally, set to a short time close to "0". We recommend setting the time according to the actual result.</p>

Step 7. Set end conditions about position

Set property (DistCheckToI) related to the end conditions of the positions.

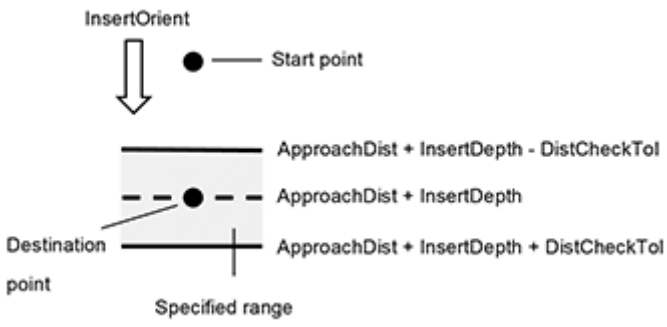
Properties	Description, setting guide
DistCheckTol	<p>This property sets the inserting direction range of the end conditions related to position. It monitors that the moving distance from the operation start point to the destination point in the direction specified by InsertOrient is within the range of ApproachDist + InsertDepth - DistCheckTol to ApproachDist + InsertDepth + DistCheckTol</p> <p>The following is an image of DistCheckTol.</p> 

4.4.6.3.2 Details on properties of Insert object

- **Name Property**
 This property sets a particular name that is assigned to force guide object. When creating the Insert sequence, name is assigned automatically. Automatically assigned name is added a number after Insert (e.g. Insert01). You can change the name. Set up 16 characters at the maximum. Please use alphanumeric characters and underscores [_]. Note: The initial character cannot be a numeric character.
- **Description Property**
 This property sets descriptions about force guide objects. You can set the character string up to 255 characters.
- **StepID Property**
 This property sets StepID during the execution of the force guide objects. It is only used when AutoStepID is False.

	Value
Minimum Value	0
Maximum value	32767

Default: Automatically set according to the numbers of the force guide sequence and the force guide object.

- **AbortSeqOnFail Property**
 This property sets operations when force guide object fails. When True is specified: If the force guide object fails, the program ends the force guide sequence and proceeds to the next SPEL statement. When specifying False: If force guide object fails, the program proceeds to the next force guide object without ending the force guide sequence. Use this property when you want to continue the force guide sequence (e.g. the recovery processes are included in the force guide sequence when the force guide object fails.)

Value	Description
True	Abort the force guide sequence when the force guide object fails.
False	Start the next force guide sequence when the force guide object fails.

Default: True

▪ SpeedS Property

This property sets speed of force guide objects during the execution. However, this set value is the speed for the set trajectory. The actual speed is adjusted by the force control functions.

	Value (unit: [mm/sec])
Minimum Value	0.1
Maximum value	100

Default: 3

▪ AccelS Property

This property sets acceleration of force guide objects. However, this set value is the acceleration for the set trajectory. The actual acceleration is adjusted by the force control functions.

	Value (unit: [mm/sec ²])
Minimum Value	1
Maximum value	1000

Default: 30

▪ ApproachDist Property

This property sets the moving distance from the start point of the force guide object to the start point of the insert operation.

	Value (Unit: [mm])
Minimum Value	0
Maximum value	50

Default: 10

▪ InsertDepth Property

This property sets the length of insertion for the workpiece.

The robot travels in the direction specified by the InsertOrient property for the force guide object in the coordinate system specified by the ForceOrient property for the force guide sequence.

	Value (Unit: [mm])
Minimum Value	0
Maximum value	300

Default: 30

▪ DecelStartRatio Property

This property sets the position at which deceleration begins.

The force guide object simultaneously executes position control and force control functions to travel from its start point for the moving distance described below. After this distance is covered, the force guide object will begin decelerating, and will operate by the force control function alone.

$\text{ApproachDist} + \text{InsertDepth} * \text{DecelStartRatio} / 100$

	Value (Unit: [%])
Minimum Value	0
Maximum value	100

Default: 80

■ InsertOrient Property

This property sets the direction of motion for insert operations in the coordinate system specified by the ForceOrient property for the force guide sequence.

Value	Description
+Fx	Sets the direction of motion to the +Fx direction in the specified coordinate system.
-Fx	Sets the direction of motion to the -Fx direction in the specified coordinate system.
+Fy	Sets the direction of motion to the +Fy direction in the specified coordinate system.
-Fy	Sets the direction of motion to the -Fy direction in the specified coordinate system.
+Fz	Sets the direction of motion to the +Fz direction in the specified coordinate system.
-Fz	Sets the direction of motion to the -Fz direction in the specified coordinate system.

Default: +Fz

■ InsertForce Property

This property sets the pressing force in the direction of motion specified by the InsertOrient property for the force guide object during the execution of the force guide object.

- InsertOrient is +Fx, +Fy, and +Fz:

	Value (unit: [N])
Minimum Value	-50
Maximum value	0

Default: -10

- If the InsertOrient is -Fx, -Fy, -Fz:

	Value (unit: [N])
Minimum Value	0
Maximum value	50

Default: 10

■ InsertFirmnessF Property

This property sets the firmness in relation to the force control function in the direction of motion specified by the InsertOrient property for the force guide object during the execution of the force guide object.

The larger the InsertFirmnessF value, the stronger the force control function becomes in the direction of motion. This slows response to changes in force, but reduces vibration.

The smaller the InsertFirmnessF value, the weaker the force control function becomes in the direction of motion. This speeds up response to changes in force, but increases vibration.

	Value
Minimum Value	0.1
Maximum value	10

Default: 3

■ FollowOrient Property

This property sets the translational and rotational following orientation set for insert operations.

This property is set automatically based on the direction of motion set by the InsertOrient property for the force guide object, and the direction of following motion set by the RotationFollowMode property. It cannot be edited.

Value	Description
FyFz	Motion following in the FyFz direction.
FxFz	Motion following in the FxFz direction.
FxFy	Motion following in the FxFy direction.
FyFzTyTz	Motion following in the FyFzTyTz direction.
FxFzTxTz	Motion following in the FxFzTxTz direction.
FxFyTxTy	Motion following in the FxFyTxTy direction.
FyFzTx	Motion following in the FyFzTx direction.
FxFzTy	Motion following in the FxFzTy direction.
FxFyTz	Motion following in the FxFyTz direction.
FyFzTxTyTz	Motion following in the FyFzTxTyTz direction.
FxFzTxTyTz	Motion following in the FxFzTxTyTz direction.
FxFyTxTyTz	Motion following in the FxFyTxTyTz direction.

Default: FxFyTxTyTz

■ FollowFirmnessF Property

This property sets the firmness in relation to the force control function for force in the following direction during the execution of the force guide object.

The larger the FollowFirmnessF value, the stronger the force control function becomes in the following direction. This slows response to changes in force, but reduces vibration.

The smaller the FollowFirmnessF value, the weaker the force control function becomes in the following direction. This speeds up response to changes in force, but increases vibration.

	Value
Minimum Value	0.1
Maximum value	10

Default: 1

■ RotationFollowMode Property

This property sets the direction in which following the direction of rotation is enabled during the execution of the force guide object.

Value	Description
Disabled	The direction of rotation is not followed.
Tilt	Following motion in the direction of tilt.
Rotate	Following motion around the axis specified for the direction of insertion.
TiltRotate	Following motion in the direction of rotation at all positions.

Default: TiltRotate

▪ FollowFirmnessT Property

This property sets the firmness in relation to the force control function for torque in the following direction during the execution of the force guide object.

The larger the FollowFirmnessT value, the stronger the force control function for torque becomes in the following direction. This slows response to changes in torque, but reduces vibration.

The smaller the FollowFirmnessT value, the weaker the force control function for torque becomes in the following direction. This speeds up response to changes in torque, but increases vibration.

	Value
Minimum Value	10
Maximum value	100000

Default: 1000

▪ ForceCheckMode Property

This property sets the direction used as an end condition related to force.

Value	Description
Insert	Applies the direction set by the InsertOrient property as the force condition.
InsertFollow	Applies the direction set by the InsertOrient property, and the direction set by the FollowOrient property as the force condition.

Default: InsertFollow

▪ InsertCheckToIF Property

This property sets the tolerance range for the force used as an end condition in the direction of motion specified by the InsertOrient property for the force guide object.

This sets the $\text{InsertForce} \pm \text{InsertCheckToIF}$ range as the end condition.

	Value
Minimum Value	0.1
Maximum value	10

Default: 1

▪ FollowCheckToIF Property

This property sets the tolerance range for the force used as an end condition in the translational direction being followed.

This sets the $\pm \text{FollowCheckToIF}$ range as the end condition.

	Value
Minimum Value	0.1
Maximum value	10

Default: 1

▪ FollowCheckToIT Property

This property sets the tolerance range for the torque used as an end condition in the rotational direction being followed.

This sets the $\pm \text{FollowCheckToIT}$ range as the end condition.

	Value
Minimum Value	1
Maximum value	10000

Default: 100

- HoldTimeThresh Property

This property sets the duration time until the determination of the end conditions related to force.

When the specified condition continues for the time specified by HoldTimeThresh, it is determined as the end conditions are satisfied.

	Value (unit: [sec])
Minimum Value	0
Maximum value	10

Default: 0.1

- DistCheckTol Property

Specify the range that is the success condition (when the operation is finished) of the distance moved from the operation start position.

The success condition is the range of ApproachDist + InsertDepth - DistCheckTol to ApproachDist + InsertDepth + DistCheckTol

	Value
Minimum Value	0.01
Maximum value	10

Default: 1

- Timeout Property

This property sets the time-out period of the force guide object.

When the robot does not satisfy the conditions enabled by InsertForce, InsertCheckToIF, FollowCheckToIF, and FollowCheckToIT even the time specified by Timeout has passed, it determines as failure of the Insert object.

After the determination, end the force guide sequence according to AbortSeqOnFail or proceed to the next force guide object.

	Value (unit: [sec])
Minimum Value	0.1
Maximum value	60

Default: 10

4.4.6.3.3 Details on results of Insert object

- EndStatus Result

It is a result of the execution.

It succeeds when the "success conditions" described in 4.2.2.2 Relax Object are satisfied.

Insert Object

Value	Description
Passed	Force guide object is succeeded.
Failed	Force guide object is failed.
NoExec	Force guide object is not executed.
Aborted	Aborted during the execution of force guide object.

- Time Result

This is the time required for execution.

Unit: [sec]

▪ **TimedOut Result**

Shows whether the time-out period set in the Timeout property was reached.

Value	Description
True	Reached the time-out period.
False	End before reaching to the time-out period.

▪ **EndForces Result**

It is force and torque when force guide object ends. Acquire values of Fx, Fy, Fz, Tx, Ty, and Tz.

Unit: Fx, Fy, Fz [N] / Tx, Ty, Tz [N · mm]

▪ **EndPos Result**

Positions when the force guide object ends. Acquire values of X, Y, Z, U, V, and W.

Unit: X, Y, Z [mm] / U, V, W [deg]

▪ **AvgForces Result**

Average values of force and torque during the force guide object execution. Acquire values of Fx, Fy, Fz, Tx, Ty, and Tz.

Unit: Fx, Fy, Fz [N] / Tx, Ty, Tz [N · mm]

▪ **PeakForces Result**

Peak values of force and torque during the force guide object execution. The peak value is a value which absolute value is the largest. Acquire values of Fx, Fy, Fz, Tx, Ty, and Tz.

Unit: Fx, Fy, Fz [N] / Tx, Ty, Tz [N · mm]

▪ **ForceCondOK Result**

Shows whether the end conditions related to force were satisfied.

Value	Description
True	Satisfy the end conditions related to force.
False	The end conditions related to force are not satisfied.

▪ **TriggeredForces Result**

It is the force and torque when satisfying the end conditions related to force. Acquire values of Fx, Fy, Fz, Tx, Ty, and Tz.

Unit: Fx, Fy, Fz [N] / Tx, Ty, Tz [N · mm]

▪ **TriggeredPos Result**

Positions when satisfying the end conditions related to force. Acquire values of X, Y, Z, U, V, and W.

Unit: X, Y, Z [mm] / U, V, W [deg]

▪ **PosCondOK Result**

Shows whether the end conditions related to position were satisfied.

Value	Description
True	Satisfy the end conditions related to position.
False	The end conditions related to position are not satisfied.

▪ **PosLimited Result**

Shows whether the limit range related to position was exceeded.

Value	Description
True	Exceed the limit range related to position.
False	The limit range related to position is not exceeded.

4.4.6.4 TensileTest Object

The TensileTest object is an object used to hold the state with applied the specified amount of force in the specified direction.

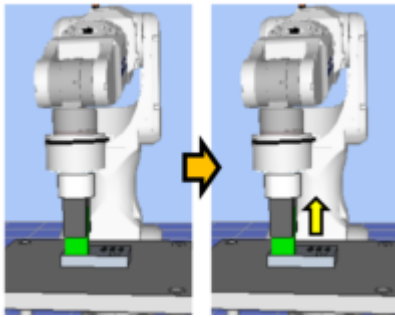

The diagram above provides a visual representation of a TensileTest object. As the yellow arrow indicates, the object holds the state to apply a constant force in the direction opposite to the insert direction inserted by the Insert object.

The TensileTest object succeeds or fails when the end conditions are met within the specified time. The TensileTest object can apply end conditions related to force and position.

Each end condition is always applied.

When all the success conditions for each end condition are met: The TensileTest object execution ends. The execution is determined as succeeded and proceed to the next force guide object.

When at least one of the failure conditions for each end condition is met: The TensileTest object execution ends. The execution is determined as failed and abort the force guide sequence.

End condition	Success condition
End conditions related to force	During the specified Timeout period, keep all of the following conditions satisfied for the length of the HoldTimeThresh period: In Fx, Fy, and Fz, the force for axis specified by InsertOrient is inside the range of TestForce - TestTolF to TestForce + TestTolF.
End conditions related to position	Satisfy the following within the specified time of Timeout. The moving distance from the force guide object start point in the direction opposite to the axis specified by InsertOrient does not exceed Clearance.

End condition	Failure condition
End conditions related to position	Satisfy the following within the specified time of Timeout. The moving distance from the force guide object start point in the direction opposite to the axis specified by InsertOrient exceeds Clearance.

4.4.6.4.1 Property guidelines for the TensileTest object

Step 1. Set basic information

Set properties (Name, Description, Enabled, StepID, AbortSeqOnFail) related to the basic information.

Properties	Description, setting guide
Name	This property sets names of force guide objects. Set a particular name.
Description	This property sets descriptions about force guide objects. Describe the operations. Set a character string.

Properties	Description, setting guide
Enabled	Set whether to execute the force guide object.
	True : Normal
	False : When you do not execute the force guide object (e.g., when you execute another force guide object instead).
StepID	StepID during the force guide object execution. Set an ID. StepID is an ID which is recorded in the log data. It helps you to understand which log data support a process. It is applied when AutoStepID of the force guide sequence is False.
AbortSeqOnFail	Set whether to abort or continue the force guide sequence when the force guide object fails.
	True : Normal End a force guide sequence.
	False : Cases where the force guide sequence contains recovery operations in case of failure; cases where the sequence will be able to continue even in the event of a failure.

Step 2. Set force control functions

Set properties (TestForce) related to the force control functions.

Properties	Description, setting guide
TestForce	Set a force to test in the tensile test direction. When InsertOrient is positive direction: Enter a negative value. When InsertOrient is negative direction: Enter a positive value. Set a proper value for your workpiece. If the value is too large, the inserted workpiece may come off. If the value is too small, the robot may not operate.

Step 3. Set basic information for end conditions

Set property (Timeout) related to time-out.

Properties	Description, setting guide
Timeout	Set the time-out duration.
	When the end conditions are not set: Time-out period is the execution time.
	When the end conditions are set: Fails when the end conditions are not satisfied within the specified time.

Step 4. Set end conditions related to force

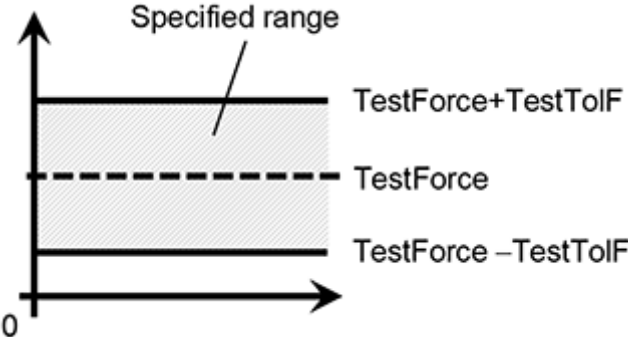
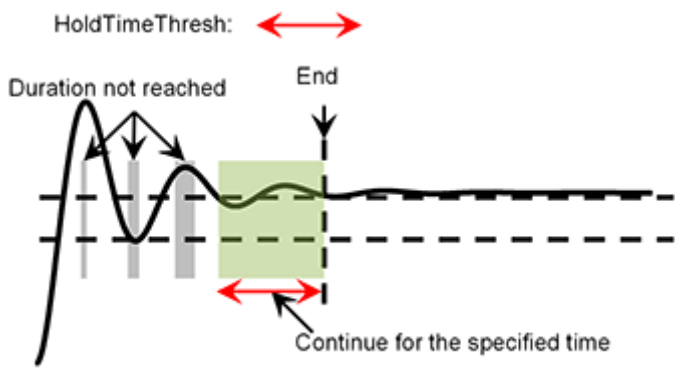
Properties	Description, setting guide
TestTolF	<p>Range of the tensile test direction of the end conditions related to force. Set a range of the end conditions.</p> <p>TestTolF is applied for Fx, Fy, and Fz.</p> <p>It monitors that the force of directions specified by InsertOrient of Fx, Fy, and Fz are within the range of TestForce -TestTolF to TestForce + TestTolF.</p> <p>The following is an image of TestTolF.</p> 
HoldTimeThresh	<p>Set the duration time which is used to determine whether the end conditions have satisfied.</p> <p>As shown below, if the specified condition continues for the time specified by HoldTimeThresh, it is determined as the end conditions are satisfied.</p>  <p>Normally, set to a short time close to "0". We recommend setting the time according to the actual result.</p>

Step 5. Set end conditions about position

Set properties (Clearance) related to the end conditions of the positions.

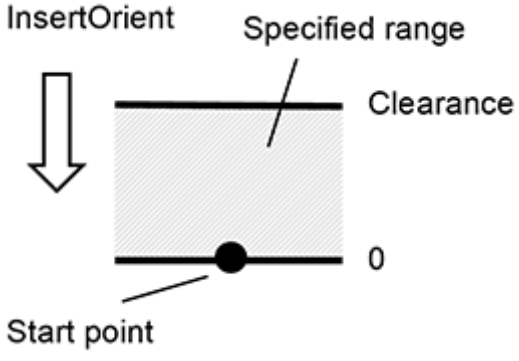
Properties	Description, setting guide
Clearance	<p>This property sets the tensile test direction range of the end conditions related to position. It monitors that the moving distance from the operation start point in the direction opposite to the direction specified by InsertOrient does not exceed Clearance.</p> <p>The following is an image of Clearance.</p> 

4.4.6.4.2 Details on the properties of the TensileTest object

- Name Property**
 This property sets a particular name that is assigned to force guide object.
 When creating the Insert sequence, name is assigned automatically. Automatically assigned name is added a number after TensileTest (e.g. TensileTest01).
 You can change the name. Set up 16 characters at the maximum. Please use alphanumeric characters and underscores [_].
 Note: The initial character cannot be a numeric character.

- Description Property**
 This property sets descriptions about force guide objects.
 You can set the character string up to 255 characters.

- Enabled Property**
 This property sets whether to execute force guide objects.

Value	Description
True	Executes a force guide object.
False	Does not execute a force guide object.

Default: True

- StepID Property**
 This property sets StepID during the execution of the force guide objects. It is only used when AutoStepID is False.

	Value
Minimum Value	0
Maximum value	32767

Default: Automatically set according to the numbers of the force guide sequence and the force guide object.

- AbortSeqOnFail Property**
 This property sets operations when force guide object fails.
 When True is specified: If the force guide object fails, the program ends the force guide sequence and proceeds to the next SPEL statement.
 When specifying False: If force guide object fails, the program proceeds to the next force guide object without ending the force guide sequence.

Use this property when you want to continue the force guide sequence (e.g. the recovery processes are included in the force guide sequence when the force guide object fails.)

Value	Description
True	Abort the force guide sequence when the force guide object fails.
False	Start the next force guide sequence when the force guide object fails.

Default: True

■ TestForce Property

This property sets the tensile force during the force guide object operation in the direction opposite to the operation specified by InsertOrient of the Insert object.

- InsertOrient is +Fx, +Fy, and +Fz:

	Value (unit: [N])
Minimum Value	0
Maximum value	50

Default: 5

- If the InsertOrient is -Fx, -Fy, -Fz:

	Value (unit: [N])
Minimum Value	-50
Maximum value	0

Default: -5

■ TestTolF Property

This property sets the tolerance of the force to be the end condition of the tensile force specified by TestForce of the force guide object.

The end condition is the range of TestForce - TestTolF to TestForce + TestTolF

	Value
Minimum Value	0.1
Maximum value	10

Default: 1

■ Clearance Property

This property sets the success condition of the moving distance from the start point of the force guide object operation to the end point of the operation. It meets the success condition if the moving distance is shorter than the specified distance.

	Value
Minimum Value	0.01
Maximum value	10

Default: 1

■ HoldTimeThresh Property

This property sets the duration time until the determination of the end conditions related to force.

When the specified condition continues for the time specified by HoldTimeThresh, it is determined as the end conditions are satisfied.

	Value (unit: [sec])
Minimum Value	0
Maximum value	10

Default: 0.1

- **Timeout Property**

This property sets the time-out period of the force guide object.

When the robot does not satisfy the conditions enabled by TestForce, and TestToIF even the time specified by Timeout has passed, it determines as failure of the TensileTest object.

After the determination, end the force guide sequence according to AbortSeqOnFail or proceed to the next force guide object.

	Value (unit: [sec])
Minimum Value	0.1
Maximum value	60

Default: 5

4.4.6.4.3 Details on the results of the TensileTest object

- **EndStatus Result**

It is a result of the execution.

It succeeds when the "success conditions" described in 4.2.2.2 Relax Object are satisfied.

Insert Object

Value	Description
Passed	Force guide object is succeeded.
Failed	Force guide object is failed.
NoExec	Force guide object is not executed.
Aborted	Aborted during the execution of force guide object.

Time Result

This is the time required for execution.

Unit: [sec]

- **TimedOut Result**

Shows whether the time-out period set in the Timeout property was reached.

Value	Description
True	Reached the time-out period.
False	End before reaching to the time-out period.

- **EndForces Result**

It is force and torque when force guide object ends. Acquire values of Fx, Fy, Fz, Tx, Ty, and Tz.

Unit: Fx, Fy, Fz [N] / Tx, Ty, Tz [N · mm]

- **EndPos Result**
Positions when the force guide object ends. Acquire values of X, Y, Z, U, V, and W.
Unit: X, Y, Z [mm] / U, V, W [deg]
- **AvgForces Result**
Average values of force and torque during the force guide object execution. Acquire values of Fx, Fy, Fz, Tx, Ty, and Tz.
Unit: Fx, Fy, Fz [N] / Tx, Ty, Tz [N · mm]
- **PeakForces Result**
Peak values of force and torque during the force guide object execution. The peak value is a value which absolute value is the largest. Acquire values of Fx, Fy, Fz, Tx, Ty, and Tz.
Unit: Fx, Fy, Fz [N] / Tx, Ty, Tz [N · mm]
- **ForceCondOK Result**
Shows whether the end conditions related to force were satisfied.

Value	Description
True	Satisfy the end conditions related to force.
False	The end conditions related to force are not satisfied.

- **TriggeredForces Result**
It is the force and torque when satisfying the end conditions related to force. Acquire values of Fx, Fy, Fz, Tx, Ty, and Tz.
Unit: Fx, Fy, Fz [N] / Tx, Ty, Tz [N · mm]
- **TriggeredPos Result**
Positions when satisfying the end conditions related to force. Acquire values of X, Y, Z, U, V, and W.
Unit: X, Y, Z [mm] / U, V, W [deg]
- **PosLimited Result**
Shows whether the limit range related to position was exceeded.

Value	Description
True	Exceed the limit range related to position.
False	The limit range related to position is not exceeded.

4.4.6.5 Adjustment Guidelines for the Insert Sequence and Object Property Values

The following section describes how to adjust when using Insert sequence and objects.

- **If GeneralObjectFailed appears as the FailedStatus result:**
A failure has occurred with a general object placed in the Insert sequence. The last executed object appears in the LastExecObject result. Adjust the property of the object that appears here by referring to the property setting guideline or adjustment guideline for the property.
- **If ForceConditionFailed appears as the FailedStatus result:**
A failure has occurred because the force did not meet the force success condition set by the object during sequence execution.
- **If an Insert object appears in the LastExecObject result:**
Reduce the Firmness value in the direction of insertion, or the following direction.
However, the robot motion may be easy to vibrate. Please perform proper adjustments for your operations.
For example, try reducing the Firmness value by 10% from its current value, and then gradually adjusting this in stages.

- If a TensileTest object appears in the LastExexObject result:
Reduce the InsertFirmnessF property for the Insert object.
However, the robot motion may be easy to vibrate. Please perform proper adjustments for your operations.
To adjust the Firmness, we recommend changing the value gradually (e.g. decrease the value by 10% from its current state).
- If PosConditionFailed appears as the FailedStatus result:
A failure has occurred because the position did not meet the position success condition set by the object during TensileTest object execution.

The operation may have failed after the Insert object was executed. Execute the force guide sequence in step execution and check whether the insert operation is performed successfully when the Insert object ends.

If successful, check the TestForce and Clearance with the specifications of the workpiece. If the TestForce is too large, the workpiece might come out even if the insert operation is successful. If the Clearance is too small, the TensileTest object will fail for not meeting the position success condition.
- If Overrun appears as the FailedStatus result:
Even though the position exceeded the position success condition range set by the object during Insert object execution, a position overrun was detected and a failure has occurred because the motion executed without enough force to satisfy the force success condition.
Check that the ApproachDist and InsertDepth values are not too small compared to the actual operating environment.
- If Jammed appears as the FailedStatus result:
A jamming failure has occurred because the position did not meet the position success condition at the point when the force satisfied the force success condition set by the object during Insert object execution.

The workpiece may be at too much of a tilt toward the hole. Check the orientation of the workpiece at the start point of the motion, and redo the teaching process.

If the teaching is correct, check that the ApproachDist and InsertDepth values are not too large compared to the actual operating environment.
- When the robot motion vibrates:
Increase the Firmness value. However, response of the robot will be slow. Please perform proper adjustments for your operations.
To adjust the Firmness, we recommend changing the value gradually (e.g. increase the value by 10% from its present state).
- When the robot bounces largely in the pressing direction:
If the robot repeatedly bounces largely in a few seconds, the robot motion may be restricted by LimitAccelS of the force guide sequence.
Also, it likely to happen during the execution in low power mode.
If the robot still bounces even executing in high power mode, increase the value of LimitAccelS. If the robot still bounces, decrease the value of Firmness in pressing direction.
- When the robot does not reach to the target force:
Decrease the Firmness value of the insertion direction.
However, the robot motion may be easy to vibrate. Please perform proper adjustments for your operations.
To adjust the Firmness, we recommend changing the value gradually (e.g. decrease the value by 10% from its current state).
- When the robot does not move to the insertion direction:
Confirm that InsertOrient is set in the direction to insert.
If it is set in the direction to insert, check if InsertForce is set to "0".

- When the robot moves in the reverse direction:
Confirm that InsertOrient is not set in the opposite direction.
When the robot is set to assumed direction, confirm the ForceOrient or RobotLocal of the force guide sequence, tool coordinate system, or local coordinate system.
- When the robot does not reach to the destination point:
If the direction where the force control functions are not enabled is not reached to the destination point, it may be affected by the LimitAccel or LimitSpeed of the force guide sequence. Increase the value.
Also, in low power mode, it is restricted according to the maximum speed or maximum acceleration of the low power mode even the value of LimitSpeed or LimitAccel is large. Be sure to execute in high power mode.

4.5 SPEL+ Programming of the Force Functions

The following describes the SPEL programming for using the force functions.

The force functions are executed using special commands added to the SPEL+ language.

Various applications can be implemented using the force functions by combining the special commands added to Force Guide 8.0 with the existing SPEL+ language.

4.5.1 SPEL+ Commands of Force Guide 8.0

The following describes the concept necessary for using the SPEL+ commands added to Force Guide 8.0.

4.5.1.1 Force object

A force object is a set of properties for each function necessary for using the force functions.

Define this object and execute each force function. A force object can be defined using a GUI such as Robot Manager or SPEL+ commands.

There are the following types of force objects.

- "Force control object" used for the force control function
- "Force trigger object" used for the force trigger function
- "Force monitor object" used for the force monitor function
- "Force motion restriction object" used for the force motion restriction function
- "Force coordinate object" used commonly for the force functions

4.5.1.2 Properties

Properties are parameters included in the force objects. The properties can be set and obtained.

The properties can be set using Force Editor before executing a program or can be changed dynamically using SPEL+ commands in a program.

An FSet statement is used to set properties. An FGet statement is used to get properties. Properties set by FSet are copied to the force file at the time when a project is loaded. The set values can be saved in the file using the FSave statement.

4.5.1.3 Status

A status is a value that is included in the force object and is returned after the force function is executed.

A status can be obtained by a SPEL+ command in a program, and the process can be branched based on it. An FGet statement is used to get a status. Each status is cleared at a unique timing. For details on when each status is initialized, refer to each status in the following manual.

"Epson RC+ 8.0 Option Force Guide 8.0 SPEL+ Language Reference"

4.5.2 SPEL+ Programming of the Force Control Function

4.5.2.1 Overview

A force control function is a function to control the robot to achieve a given target force and torque using the Force Sensor. Programming of the force control function is performed with the following procedure.

Set the coordinate system to be executed

Set the parameters

Execute the force control function

4.5.2.2 Coordinate System of the Force Control Function

The force control function works in the force coordinate system.

The force control function calculates the force detected by the sensor, the force applied to the force coordinate system by the torque, and the torque itself, and controls the robot while moving and rotating the force coordinate system according to the results of the calculations.

Specify the origin of the force coordinate system in a point where contact actually occurs and a force is generated. (Example: Tip point of a workpiece)

Furthermore, the orientation of the force coordinate system varies depending on the application. When executing the force control function in a constant direction, regardless of the posture of the robot, like a case where a force is always applied in the vertical downward direction, specify the base coordinate system and local coordinate system.

When executing the force control function in a direction that changes according to the posture of the robot, like a case where a force is applied in a direction of the workpiece held by the robot, specify the tool coordinate system and custom coordinate system.

The force control function can be executed for the six axes (Fx to Tz) specified in the force coordinate system.

4.5.2.3 Parameters of the Force Control Function

Parameters of the force control function are defined in the properties of the force control object.

They can be set in the GUI before executing a program. For details on the settings in the GUI, refer to the following section.

Software: [Robot Manager] **[Tools] menu**

- [Tools]-[Robot Manager]-[Force] Panel

If you want to dynamically change the parameters during executing a program, they can be set using an FSet statement.

- **CoordinateSystem Property**

Specify the force coordinate object for which the force control function is executed.

Changing only the CoordinateSystem property enables the force control function with the same control characteristics to be executed in another coordinate system.

- **Enabled Property**

Specify the axes (Fx to Tz) on which the force control function is executed.

You can enable only the axes necessary for an application; for example, you can enable Fx to Fz and disable Tx to Tz to execute the force control function only in the translation direction.

- **TargetForce Property**

Set the target force and torque of the force control function for each axis.

The robot moves to detect the set force. Note that if a positive value is set, the robot moves in a negative direction to apply a force in the positive direction of the force coordinate system.

If you want to perform the pressing operation in the positive direction of the force coordinate system, set a negative target force.

The robot moves not to apply a force if the TargetForce property is set to 0. The robot can move while following the external force.

- **Spring Property**

Set the spring value of the force control function.

Setting the Spring property enables the force control function to work as if there is a virtual spring, and if an external force is applied, the robot moves to the position to counterbalance the force, and if the applied external force is removed, the robot returns to the original position.

Increasing the value moves the robot as if a harder spring is provided. If "0" is set, there is no virtual spring, so the robot moves as far as it can according to the force.

- **Damper Property**

Set the damper value of the force control function.

Decreasing the Damper property value increases the response of the force control function to changes in the force, but makes the motion of the robot more vibratory due to the environments such as posture, Hand, and workpieces. To adjust the Damper property value, decrease the default value gradually.

- **Mass Property**

Set the mass value of the force control function.

Setting a large value for the Mass property increases the overshoot until the target force is achieved and increases the hunting period. Set the Mass and Damper property values so they are about 1:1 to 10:1 in the translation direction and about 1:1 to 1000:1 in rotation to perform stable control.

However, note that the motion may be vibratory, or a ratio larger than those may be appropriate for some applications or operating conditions.

If the Mass property value is too small compared to that of the Damper property value, an error may occur when the force control function is executed.

- **TargetForcePriorityMode Property**

Set the target force priority mode of the force control function.

The target force may not be able to be achieved after the passing of enough time for some operating conditions such as mechanical rigidity. In this case, enabling the target force priority mode increases the movement and reduces the time to achieve the target force. However, the movement will differ from that specified in Spring, Damper, and Mass. Normally, disable the target force priority mode, and use the mode only when necessary upon fully understanding the characteristics.

- **LimitSpeed Property**

Set the maximum value of the speed at which the hand tip of the robot works during executing of the force control function.

Specify the three values of translation, rotation, and joint speed. The speed is automatically limited to the specified maximum value during executing of the force control function. This property is useful, for example, if you need to move the robot in a high power mode to perform a pressing operation with a strong force, but want to move it at a low speed.

- **LimitAccel Property**

Set the maximum value of the acceleration at which the hand tip of the robot works during executing of the force control function.

Specify the three values of translation, rotation, and joint acceleration. The acceleration is automatically limited to the specified maximum value during executing of the force control function.

4.5.2.4 Executing the Force Control Function

The force control function is executed alone as an operation command, or the position control and force control functions are executed simultaneously by adding a modification parameter to the operation command of the position control. When the force control function is executed, the operation always changes depending on the output of the Force Sensor, so that the robot does not reach the target position of the position control, but even though the same command is executed, the operation ends at different positions every time.

To execute only the force control function, execute the FCKeep statement. The following operation commands can be used in combination with the force control function: Move, BMove, TMove, CVMove, FCMove, Arc, and Arc3 statements. To execute the force control function, add the force control object to each statement as a modification parameter.

Example of combination of the force control function with Move:

```
Move P1 FC1
```

For details on each statement, refer to the following manual.

- "Epson RC+ 8.0 SPEL+ Language Reference"
- "Epson RC+ 8.0 Option Force Guide 8.0 SPEL+ Language Reference"
For details on operation commands with the force control function enabled, refer to the following manual.
- "Epson RC+ 8.0 Option Force Guide 8.0 SPEL+ Language Reference"
- Move

The force control function starts at the same time as the operation command and stops when the travel time calculated at the time when the operation command started has elapsed. The execution of the force control function can be continued after the operation command ends by adding a CF modification parameter. However, if another force control function does not execute an effective operation command or a command to stop the force control function within 60 seconds, an error occurs.

Use an FCKeep statement, for example, in standby mode for a certain period of time with the force control function enabled after an operation command is executed.

The operation end conditions of the force control function (for example, the force control function works until a specified force is reached) can be set in combination with the Till modification parameter or force trigger function.

Key Point

Since errors are accumulated due to a drift of the Force Sensor, the force control function must be executed within 10 minutes after resetting the Force Sensor. The Force Sensor should be reset immediately before using the force control function with no external force applied to it, and should be executed in as short a period of time as possible.

Key Point

The force control function cannot be executed near the singular point of the robot. Execute the force control function avoiding the vicinity of the singular point. If the robot approaches the vicinity of the singular point during executing of the force control function, an error occurs.

4.5.3 SPEL+ Programming of the Force Trigger Function

4.5.3.1 Overview

A force trigger function is a function to detect that the force and torque measured using the Force Sensor reached the set value. The process can be started, ended, and branched using the results.

Programming of the force trigger function is performed with the following procedure.

1. Set the coordinate system to be executed
2. Set the parameters
3. Execute the force trigger function

4. Get the results

4.5.3.2 Coordinate System of the Force Trigger Function

The force trigger function works in the force coordinate system.

The force trigger function calculates the force detected by the Force Sensor, the force applied to the force coordinate system by the torque, and the torque itself, and monitors whether the values met the set conditions.

Specify the origin of the force coordinate system in a point where contact actually occurs and a force is generated. (Example: Tip point of a workpiece)

Furthermore, the orientation of the force coordinate system varies depending on the application. When monitoring the force in a constant direction, regardless of the posture of the robot, specify the base coordinate system and local coordinate system.

When monitoring the force in a direction that changes according to the posture of the robot, specify the tool coordinate system and custom coordinate system.

The force trigger function can monitor the following total of 8-dimensional data specified in the force coordinate system.

- Six axes Fx to Tz
- Fmag: Composite translation force
- Tmag: Composite torque

4.5.3.3 Parameters of the Force Trigger Function

Parameters of the force trigger function are set in the properties of the force trigger object.

They can be set in the GUI before executing a program. For details on the settings in the GUI, refer to the following section.

Software: [Robot Manager] **[Tools] menu**

- [Tools]-[Robot Manager]-[Force] Panel

If you want to dynamically change the parameters during executing a program, they can be set using an FSet statement.

- ForceSensor Property
Specify the Force Sensor number to execute the force trigger function.
- CoordinateSystem Property
Specify the force coordinate object for which the force trigger function is executed.
- Operator Property
Specify the criterion for meeting the condition of the force trigger function; specifically whether all conditions for each axis are met or whether the conditions of a particular axis are met.
- TriggerMode Property
Specify whether to monitor the force and torque, or to monitor the changes in the force and torque.
If a change value is specified, the change value per second is monitored. Since the Force Sensor is susceptible to noise, use a low-pass filter.
- Fmag_Axes Property
Specify the axis from the axes (Fx to Fz) to be combined to calculate the Fmag value.
To monitor the force applied to the X-Y plane, specify the direction to be monitored; for example, specify the X and Y axes.
- Tmag_Axes Property
Specify the axis from the axes (Tx to Tz) to be combined to calculate the Tmag value.
- Enabled Property
Specify the axis (Fx to Tmag) on which the force trigger function is executed.
The force trigger function can be enabled only for the axes necessary for an application.
- Polarity Property
Specify the criterion for meeting the condition, whether the force and torque for each axis falls inside or outside the

upper/lower threshold ranges.

To detect that a force outside the threshold range is applied, specify outside.

To detect that a force inside the threshold range is applied, specify inside.

- UpperLevel Property

Set the upper level of the force trigger function.

This function monitors whether the value is below or rises above the set value.

- LowerLevel Property

Set the lower level of the force trigger function.

This function monitors whether the value is above or falls below the set value.

- LPF_Enabled Property

Specify the axis (Fx to Tmag) on which the low-pass filter is executed in the force trigger function.

Use this property to reduce the noise or when ignoring Force Sensor values such as impulse.

- LPF_TimeConstant Property

Specify the time constant of the low-pass filter to be executed in the force trigger function.

Increasing the value reduces the noise, but also reduces the response to the Force Sensor values.

4.5.3.4 Executing the Force Trigger Function

The force trigger function can be specified by Till, Wait, Trap, and Find.

For the basic functions of the commands, refer to the following manual.

"Epson RC+ 8.0 SPEL+ Language Reference"

The following describes the force trigger function. Up to 15 force triggers for monitoring can be set for each robot simultaneously. Do not use more than 16 force motion restrictions for one robot simultaneously.

- Till

Specifying the force trigger object in the event expression of the Till statement sets the end condition for the operation of the force trigger function. Thus, when the force reaches the specified value, the operation ends.

Use example:

```
Till FT1
Move P1 FC1 Till
```

The force trigger is set to the Till condition by the Till statement. When the condition set in force trigger object FT1 is met during Move operation, the Move operation stops even if part way through the operation and the next statement is executed.

- Trap

Specifying the force trigger object in the event expression of the Trap statement sets the condition for the force trigger function to start the interrupt processing. Thus, the force is always monitored, and when the force reaches the specified value, the interruption starts.

Use example:

```
Trap 1, FT1 Goto TrapLabel
```

The force trigger function is executed by the Trap statement to start monitoring of the condition. When the condition set in force trigger object FT1 is met, the transition to the specified label occurs.

- Wait

Specifying the force trigger object in the event expression of the Wait statement sets the condition for the force trigger function to end the standby state. Thus, the force trigger function stands by until the force reaches the specified value.

Use example:

```
Wait FT1
```

The force trigger function is executed by the Wait statement to start monitoring of the condition. The program is stopped until the condition set in force trigger object FT1 is met, and the program is restarted when the condition is met.

- Find

Specifying the force trigger object in the event expression of the Find statement sets the condition to save the coordinates while the force trigger function is in operation. Thus, the position at which the specified force is reached is recorded.

Use example:

```
Find FT1
P0=FindPos
```

The force trigger function is executed by the Find statement to start monitoring of the condition. The Controller memorizes the position at which the condition set in force trigger object FT1 is met and gets that position with the FindPos function.

The force trigger function can get the position at which the condition is met using the TriggeredPos status. Therefore, Find is useful when specifying an event expression combining multiple conditions. The TriggeredPos status can be used to get the position at which the condition set in the force trigger object is met. The FindPos function can be used to get the position at which an event expression combining multiple conditions is met.

Do not delete the force trigger object which starts monitoring by using FDel statement. When creating a program in multiple tasks, be careful not to execute Till, Wait, Trap, and Find simultaneously which specified force trigger objects.

4.5.3.5 Getting the Results of the Force Trigger Function

Specifying the status of the force trigger object using the FGet statement after executing the force trigger function can get the results. The acquired results can be used to determine the pass or fail of the operation, or perform conditional branching.

The status is initialized when the force trigger function is executed, and the result is set when the force trigger function ends. The set result is retained until either the force trigger function is executed again or a project is loaded.

- Triggered Status

Returns the status of achievement of the force trigger condition.

Returns "True" if the condition is achieved in the previous force trigger condition. This result can be used to determine whether the force exceeded the specified value, and branch the process.

- TriggeredAxes Status

Returns the status of achievement of the force trigger condition for each axis.

It can determine more detailed conditions; for example, determine the axis on which the force exceeded the specified value, and branch the process.

- TriggeredPos Status

Returns the coordinates at which the force trigger condition was achieved.

It can determine whether the position at which the condition was achieved is within the specified range, and branch the process according to the position.

4.5.4 SPEL+ Programming of the Force Monitor Function

4.5.4.1 Overview

A force monitor function is a function to measure the force and torque using the Force Sensor.

The results can be used to adjust the parameters when an application is created, or record and manage the forces applied to each workpiece during the operation.

Programming of the force monitor function is performed with the following procedure.

1. Set the coordinate system to be executed
2. Set the parameters
3. Execute the force monitor function and take measurements

4.5.4.2 Coordinate System of the Force Monitor Function

The force monitor function works in the force coordinate system.

The force monitor function calculates the force detected by the Force Sensor, the force applied to the force coordinate system by the torque, and the torque itself, gets the values, and calculates the average and peak values.

Specify the origin of the force coordinate system in a point where contact actually occurs and a force is generated. (Example: Workpiece edge point, etc.)

Furthermore, the orientation of the force coordinate system varies depending on the application. When measuring the force in a constant direction, regardless of the posture of the robot, specify the base coordinate system and local coordinate system. When measuring the force in a direction that changes according to the posture of the robot, for example, in the forward direction of a workpiece held by the robot, specify the tool coordinate system and custom coordinate system.

The force monitor function can measure the following total of 8-dimensional data specified in the force coordinate system.

- Six axes F_x to T_z
- F_{mag} : Composite translation force
- T_{mag} : Composite torque

4.5.4.3 Parameters of the Force Monitor Function

Parameters of the force monitor function are set in the properties of the force monitor object. They can be set in the GUI before executing a program. For details on the settings in the GUI, refer to the following section.

Software: [Robot Manager] [\[Tools\] menu](#)

- [Tools]-[Robot Manager]-[Force] Panel

If you want to dynamically change the parameters during executing a program, they can be set using an FSet statement.

- ForceSensor Property
Specify the Force Sensor number to execute the force monitor function.
- CoordinateSystem Property
Specify the force coordinate object for which the force monitor function is executed.
- F_{mag_Axes} Property
Specify the axis from F_x to F_z to be combined to calculate the F_{mag} value.
To measure the force applied horizontally to the X-Y plane, specify the direction to be measured; for example, specify the X and Y axes.
- T_{mag_Axes} Property
Specify the axis from the axes (T_x to T_z) to be combined to calculate the T_{mag} value.
- LPF_Enabled Property
Specify the axis (F_x to T_{mag}) on which the low-pass filter is executed in the force monitor function.
Use this property to reduce the noise or when ignoring Force Sensor values such as impulse.

- **LPF_TimeConstant Property**
Specify the time constant of the low-pass filter to be executed in the force monitor function.
Increasing the value reduces the noise, but also reduces the response to the Force Sensor values.

4.5.4.4 Executing the Force Monitor Function

The following operations can be performed with the force monitor function.

- Getting the Force Sensor Values
- Recording the Force Sensor Values
- Getting the Average Value
- Getting the Peak Value

Getting the Force Sensor Values

Execute the `Force` property of the force monitor object to get the Force Sensor values.

Use example:

```
FGet FM1.Forces, rVar()
```

Get the 8-dimensional Force Sensor values for Fx to Tmag in real array variable `rVar`. The Force Sensor values to be acquired are the latest values.

Getting the Average Value

Execute the `AvgForceClear` property of the force monitor object to start calculating the Force Sensor average value.

After the start, the average value can be acquired using the `AvgForce` status.

Use example:

```
FSet FM1.AvgForceClear, True, True, True, True, True, True, True, True
FGet FM1.AvgForces, rVar()
```

Get the 8-dimensional Force Sensor average value for Fz to Tmag in real array variable `rVar`.

Before executing the `AvgForce` status, be sure to start calculating the average value using the `AvgForceClear` property.

If the calculation is not started, "0" is acquired.

Executing the `AvgForce` status stops the calculation of the average value. To get the average value consecutively, every time the average value is acquired, start calculating the average value again and then get the average value.

Executing the `AvgForce` status more than one minute after starting calculating the average value causes an error to occur. Either execute the `AvgForce` status within one minute or start calculating the average value again.

Getting the Peak Value

Execute the `PeakForceClear` property of the force monitor object to start calculating the Force Sensor peak value.

After the start, the peak value can be acquired using the `PeakForce` status.

Use example:

```
FSet FM1.PeakForceClear, True, True, True, True, True, True, True, True
FGet FM1.PeakForces, rVar()
```

Get the 8-dimensional Force Sensor peak value for Fx to Tmag in real array variable `rVar`.

Before executing the `PeakForce` status, be sure to start calculating the peak value using the `PeakForceClear` property. If the calculation is not started, "0" is acquired.

Executing the `PeakForce` status stops the calculation of the peak value. To get the peak value consecutively, every time the peak value is acquired, start calculating the peak value again and then get the peak value.

Recording the Force Sensor Values

Execute the `LogStart` property of the force monitor object to record the Force Sensor values in a file.

This enables information on each operation to be stored in a file.

Use example:

```
FSet FM1.Label, "ForceLog"
FSet FM1.RecordStart, 30, 0.1
```

With the RecordStart property, start recording Force Sensor values, etc to the file for 30-second periods, with 0.1-second intervals. Before recording begins, the file name is determined from the label and start time specified in the Label property. After starting recording, the program goes to the next statement.

4.5.5 SPEL+ Programming of the Force Motion Restriction Function

4.5.5.1 Overview

A force motion restriction function is a function to detect the robot position or posture reaches the set value.

The process can be started, ended, and branched using the results.

Programming of the force motion restriction function is performed with the following procedure.

1. Set the parameters
2. Execute the force motion restriction function
3. Get the results

4.5.5.2 Parameters of the Force Motion Restriction Function

Parameters of the force motion restriction function are set in the properties of the force motion restriction object.

They can be set in the GUI before executing a program. For details on the settings in the GUI, refer to the following section.

Software: [Robot Manager] [\[Tools\] menu](#)

- [Tools]-[Robot Manager]-[Force] Panel

If you want to dynamically change the parameters during executing a program, they can be set using an FSet statement.

- ForceSensor Property
Specify the Force Sensor number that is the target of the force and torque to be recorded when the conditions of the force motion restriction function are achieved.
- CoordinateSystem Property
Specify the force coordinate system object that specifies the force coordinate system of the force and torque to be recorded when the conditions of the force motion restriction function are achieved.
- Operator Property
Specify the criterion for meeting the condition of the force trigger function; specifically whether all conditions for each axis are met or whether the conditions of a particular axis are met.
- RobotLocal Property
Specify the local coordinate system that is the reference for the position monitored by the force motion restriction function.
- RobotTool Property
Specify the tool coordinate system that is the reference for the position monitored by the force motion restriction function.
- TriggerMode Property
Specify the position to be monitored.
For details on each mode, refer to the following manuals:
"Epson RC+ 8.0 Option Force Guide 8.0 SPEL+ Language Reference"
- DatumPoint Property
Specify the reference point when RelativePoint is set for TriggerMode.
- Dist_Axes Property
Specify which axis of X, Y, and Z is used to calculate the distance.
- Rot_Axes Property
Specify which axis of X, Y, and Z is used to calculate the angle.
- Enabled Property
Specify the axis for executing the force motion restriction function for PosX to J6.
You can enable the force motion restriction function only for the axes required by the application.

- **Polarity Property**
Specify the criterion for meeting the condition, whether the position, angle, and indirectly position falls inside or outside the upper/lower threshold ranges.
To detect that the robot moves to the position and posture outside the threshold range, specify outside.
To detect that the position and posture is inside the threshold range, specify inside.
- **UpperLevel Property**
Set the upper level of the force motion restriction function.
This function monitors whether the value is below or rises above the set value.
- **LowerLevel Property**
Set the lower level of the force motion restriction function.
This function monitors whether the value is above or falls below the set value.

4.5.5.3 Executing the Force Motion Restriction Function

The force motion restriction function can be specified by Till, Wait, Trap, and Find.

For the basic functions of the commands, refer to the following manual.

Epson RC+ 8.0 SPEL+ Language Reference

The following describes the force motion restriction function. Up to 15 force motion restrictions for monitoring can be set for each robot simultaneously. Do not use more than 16 force motion restrictions for one robot simultaneously.

- **Till**
Specifying the force motion restriction object in the event expression of the Till statement sets the end condition for the operation of the force motion restriction function. Thus, when the force reaches the specified value, the operation ends.

Use example:

```
Till FMR1
Move P1 FC1 Till
```

The force motion restriction is set to the Till condition by the Till statement. When the condition set in force motion restriction object FMR1 is met during Move operation, the Move operation stops even if part way through the operation and the next statement is executed.

- **Trap**
Specifying the force motion restriction object in the event expression of the Trap statement sets the condition for the force motion restriction function to start the interrupt processing. Thus, the position/posture is always monitored, and when the position/posture reaches the specified value, the interruption starts.

Use example:

```
Trap 1, FMR1 Goto TrapLabel
```

The force motion restriction function is executed by the Trap statement to start monitoring of the condition. When the condition set in force motion restriction object FMR1 is met, the transition to the specified label occurs.

- **Wait**
Specifying the force motion restriction object in the event expression of the Wait statement sets the condition for the force motion restriction function to end the standby state. Thus, the force motion restriction function stands by until the position/posture reaches the specified value.

Use example:

```
Wait FMR1
```

The force motion restriction function is executed by the Wait statement to start monitoring of the condition. The program is stopped until the condition set in force motion restriction object FMR1 is met, and the program is restarted when the condition is met.

- Find

Specifying the force motion restriction object in the event expression of the Find statement sets the condition to save the coordinates while the force motion restriction function is in operation. Thus, the position at which the specified position/posture is reached is recorded.

Use example:

```
Find FMR1
Move P1 FC1 Find
P0=FindPos
```

The force motion restriction is set to the Find condition by the Find statement, and when the condition set on the force motion restriction object FMR1 is reached during the Move operation, the controller memorizes the position where the condition is met, and gets that position with the FindPos function.

The force motion restriction function can get the position at which the condition is met using the TriggeredPos status. Therefore, Find is useful when specifying an event expression combining multiple conditions. The TriggeredPos status can be used to get the position at which the condition set in the force motion restriction object is met. The FindPos function can be used to get the position at which an event expression combining multiple conditions is met.

Do not delete the force motion restriction object which starts monitoring by using FDel statement. When creating a program in multiple tasks, be careful not to execute Till, Wait, Trap, and Find simultaneously which specified force motion restriction objects.

4.5.5.4 Getting the Results of the Force Motion Restriction Function

Specifying the status of the force motion restriction object using the FGet statement after executing the force motion restriction function can get the results. The acquired results can be used to determine the pass or fail of the operation, or perform conditional branching.

The status is initialized when the force motion restriction function is executed, and the result is set when the force motion restriction function ends. The set result is retained until either the force motion restriction function is executed again or a project is loaded.

- Triggered Status

Returns the status of achievement of the force motion restriction condition.

Returns "True" if the condition is achieved in the previous force motion restriction condition. This result can be used to determine whether the position/posture exceeded the specified value, and branch the process.

- TriggeredAxes Status

Returns the status of achievement of the force motion restriction condition for each axis.

It can determine more detailed conditions; for example, determine the axis on which the force exceeded the specified value, and branch the process.

- TriggeredPos Status

Returns the coordinates at which the force motion restriction condition was achieved.

It can determine whether the position at which the condition was achieved is within the specified range, and branch the process according to the position.

- TriggeredForces Status

Returns the force and torque when the force motion restriction condition is reached.

It can determine whether the force at which the condition was achieved is within the specified range, and branch the process according to the force.

4.5.6 Example of a Force Function Program

The following describes an example of a simple operation in combination with the force functions.

⚠ CAUTION

The parameters described in the example are reference values.

Please note that relatively stable parameters are used, but in some operating conditions, the operation may not succeed or there may be vibrations in the motion, in which case the parameters may need to be adjusted. note that

In addition, slow stable parameters are used for convenience of explanation. For high-speed operation, adjusting the parameters is required.

4.5.6.1 Pressing Operation

The following describes an example of a program to perform a pressing operation in a constant direction with a target force.

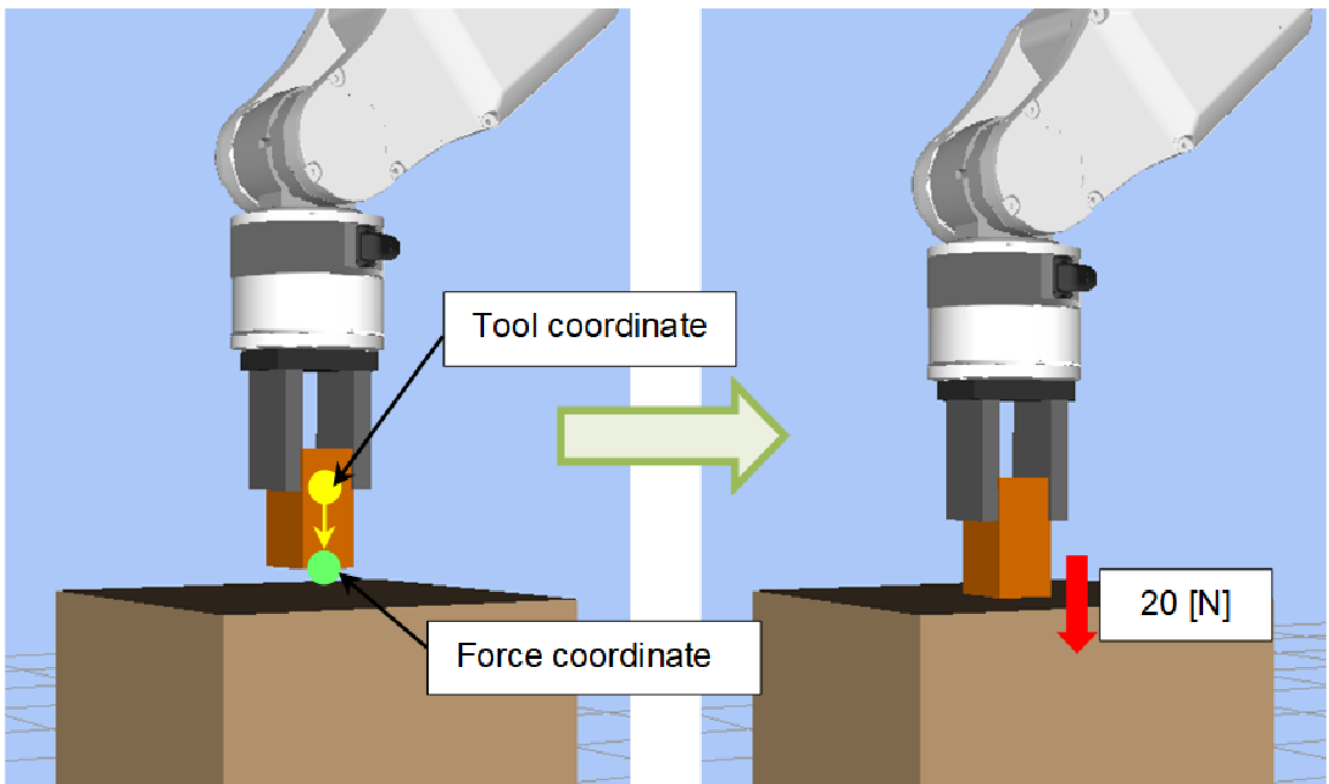

The example operation is to move a workpiece to the position 10 [mm] above the contact position and use the force control function to press the workpiece held by the hand against the worktable with a force of 20 [N].

At the same time, the force trigger function is used to monitor excessive force (100 [N] or more) during the operation, and detecting excessive force causes an error to occur.

Furthermore, when the force motion restriction function is used to operate an unexpected movement (20 [mm] or more) during the operation, the robot will stop operating as an abnormal state in which the worktable does not exist.

Furthermore, the force monitor function is used to measure the Force Sensor values after the operation is completed and also measure the maximum force applied during the operation.

The tool coordinate system is set in the hand tip, and the forward direction of the hand is the Tlz axis direction.

4.5.6.2 Sample Program

```

Function PressSample_Main
  Real rVar(8)
  Integer iVar
  Motor On
  Go P0                                ' Go to the operation start position
  PressSample_PropertySetting          ' Set the property
  FSet FS1.Reset                       ' Reset the Force Sensor
  Trap 1, FT1 Call PressSample_EHandle ' Start monitoring excessive force
  FSet FM1.PeakForceClear, True, True, True, False, False, False, True, False
    ' Start calculating the peak value
  Till FMR1                            ' Set the motion aborting condition for
when the robot moves outside the expected range
  FCKeep FC1 Till, 10                   ' Execute the force control function for 10
seconds
  Print "Motion End"
  FGet FM1.Forces, rVar()               ' Get the Force Sensor value
  Print "Force Fz:", rVar(FG_FZ), ", Fmag:", rVar(FG_FMAG)
  FGet FM1.PeakForces, rVar()          ' Get the peak value
  Print "PeakForce Fz:", rVar(FG_FZ), ", Fmag:", rVar(FG_FMAG)
  FGet FMR1.Triggered, iVar            ' Get result of movement restriction
  If iVar = True Then                  ' If restricted, display the Overrun error
    Print "Overrun Error"
  EndIf
Fend

Function PressSample_PropertySetting
  FSet FCS1.Position, 0, 0, 30          ' The origin of the force coordinate system
is Z30 mm
  FSet FCS1.Orientation, FG_TOOL       ' The orientation is aligned with the tool
coordinate system

  FSet FC1.CoordinateSystem, FCS1      ' Specify the defined force coordinate No.
1
  FSet FC1.Enabled, False, False, True, False, False, False
    'Enable the force control function only for the Fz direction.
  FSet FC1.Fz_TargetForce, -20         ' Pressing of 20 N
  FSet FC1.Fz_Spring, 0                ' The spring value is 0
  FSet FC1.Fz_Damper, 10               ' The damper value is 10
  FSet FC1.Fz_Mass, 10                 ' The mass value is 10

  FSet FT1.ForceSensor, 1              ' Specify Force Sensor No. 1
  FSet FT1.CoordinateSystem, FCS1      ' Specify the defined force coordinate No.
1
  FSet FT1.TriggerMode, FG_FORCE       ' Monitor the force
  FSet FT1.Fmag_Axes, FG_XYZ
  FSet FT1.Enabled, False, False, False, False, False, False, True, False
    'Enable only Fmag
  FSet FT1.Fmag_Polarity, FG_OUT       ' Trigger detects when the value falls
outside the threshold range
  FSet FT1.Fmag_Levels, 0, 100         ' The range of Fmag is 0 to 100

  FSet FM1.ForceSensor, 1              ' Specify Force Sensor No. 1
  FSet FM1.CoordinateSystem, FCS1      ' Specify the defined force coordinate No.
1

  FSet FMR1.TriggerMode, FG_REL_TOOL   'Specify tool relative mode
  FSet FMR1.PosEnabled, False, False, True, False, False
    'Enable only Z direction

```



```

FSet FMR1.PosZ_Levels, -20, 20 ' Z range is -20mm to 20mm
FSet FMR1.PosZ_Polarity, FG_OUT ' Enable the restriction when the value
falls outside the threshold range
FSet FMR1.ForceSensor, 1 ' Specify Force Sensor No. 1
FSet FMR1.CoordinateSystem, FCS1 ' Specify the defined Force coordinate No.
1
Fend

Function PressSample_EHandle
Real rVar(8)
FGet FM1.PeakForces, rVar() ' Get the peak value
Print "Error Handle"
Print "PeakForce Fz:", rVar(FG_FZ), ", Fmag:", rVar(FG_FMAG)
AbortMotion All ' Abort the robot motion and put it into an
error state
Fend

```

4.5.6.3 Description

1. Executing the PressSample_Main function moves the robot to the operation start position.
2. Call PressSample_PropertySetting and execute the settings of the properties.
However, the settings of the properties can also be configured beforehand in Force Editor in the GUI. In this case, there is no need to call the PressSample_PropertySetting.
3. Set the force coordinate object. For the force coordinate system, specify the Z30 [mm] position in the example to specify the workpiece edge position in the tool coordinate system. The orientation is the same as the orientation of the tool coordinate system.
4. Set the force control object. Specify FCS1 set as the coordinate system in which the force control function is executed. Specify a negative value for the target force, as the pressing operation is performed in the positive FZ direction. Set the spring, damper, and mass values. "0" is set in Spring in this example, so the robot does not have a virtual spring and continues to move until the target force is achieved. In addition, stable parameters are used for Damper and Mass. For faster operations, adjust these values by decreasing them gradually. However, decreasing the values increases the overshoot of the force.
5. Set the force trigger object. Specify the Force Sensor number to be used and the coordinate system in which the force trigger function is executed. Specify a force in the TriggerMode property to monitor excessive force. Specify X, Y, and Z, as the composite force to be monitored is calculated using all Fx to Fz. Specify 0 to 100 [N] for the Fmag range to set 100 [N] for the excessive force, and configure to monitor whether the value falls outside this range.
6. Set the force monitor object. Specify the Force Sensor number for measurement and the coordinate system.
7. Set the force motion restriction object. The robot moves in the + Z direction of the tool coordinate system according to the settings in (a) and (b). In the example, if the robot moves more than 20 mm, the setting to detect that there is no object to press is performed. Specify the tool relative mode for TriggerMode to detect the moving distance of the tool coordinate system. In Enabled, enable only PosZ to detect the Z direction. Specify -20 to 20 [mm] as the range in the Z direction, and set to monitor whether it is outside this range.
8. Reset the Force Sensor before using the force functions.
9. Specify the force trigger object in Trap and execute the force trigger function. Thus, excessive force is monitored.
10. Set the force motion restriction object to the Till condition.
11. Calculation of the peak value of the force applied during the operation starts.
12. Execute the force control function for 10 seconds. During execution, if the force motion restriction condition specified in the Till condition is met, the operation is aborted.
13. Get and display the current and peak values of the Force Sensor. In this example, only the values are displayed. These values can be used to determine the pass or fail of the operation and branch the process.
14. Get the result of force motion restriction. In this example, if the condition is met, an error is only displayed as an overrun, but recovery processing etc. can also be performed.

15. If excessive force is detected during the operation, the program is aborted and the PressSample_EHandle function is interrupted and executed. The peak value applied during the operation is acquired and displayed, the robot motion is aborted, and an error state is entered. In this example, an error state is entered, but processes in the event of an error, such as a retry, also can be executed.

4.6 Tutorial

Tutorial describes basic operation steps of Force Guide 8.0 by the following operations or motions.

Tutorial for Force Guidance Function

Tutorial using general sequence

Force Guidance Function (pressing to vertical-downward)

Force Guidance Function (USB Connector Insertion)

Force Guidance Function (Peg In Hole)

Force Guidance Function (Screw Driving)

Tutorial using system sequence

Paste Sequence

Screw Tighten Sequence

Height Inspect Sequence

Insert Sequence

Tutorial for SPEL+ command

Command Version (Simple Pressing)

Before starting Tutorial, make sure that the following connections or settings have completed properly:

- Epson's sensor flange is used
- Force Sensor is installed on the robot
- Force Sensor is connected to Force Sensor I/F unit or the sensor 1 of the board
- • Force Sensor I/F unit is connected to Controller Or Force Sensor I/F board is connected to Controller properly
- Epson RC+ can be communicated with Controller
- Robot and Controller are connected
- Robot is registered as robot 1

For details on connection or settings, refer to the next chapter and the following manuals:

- Hardware **How to Install**
- "Epson RC+ 8.0 User"s Guide 3. Getting Started10. Robot Configuration

Overall flow

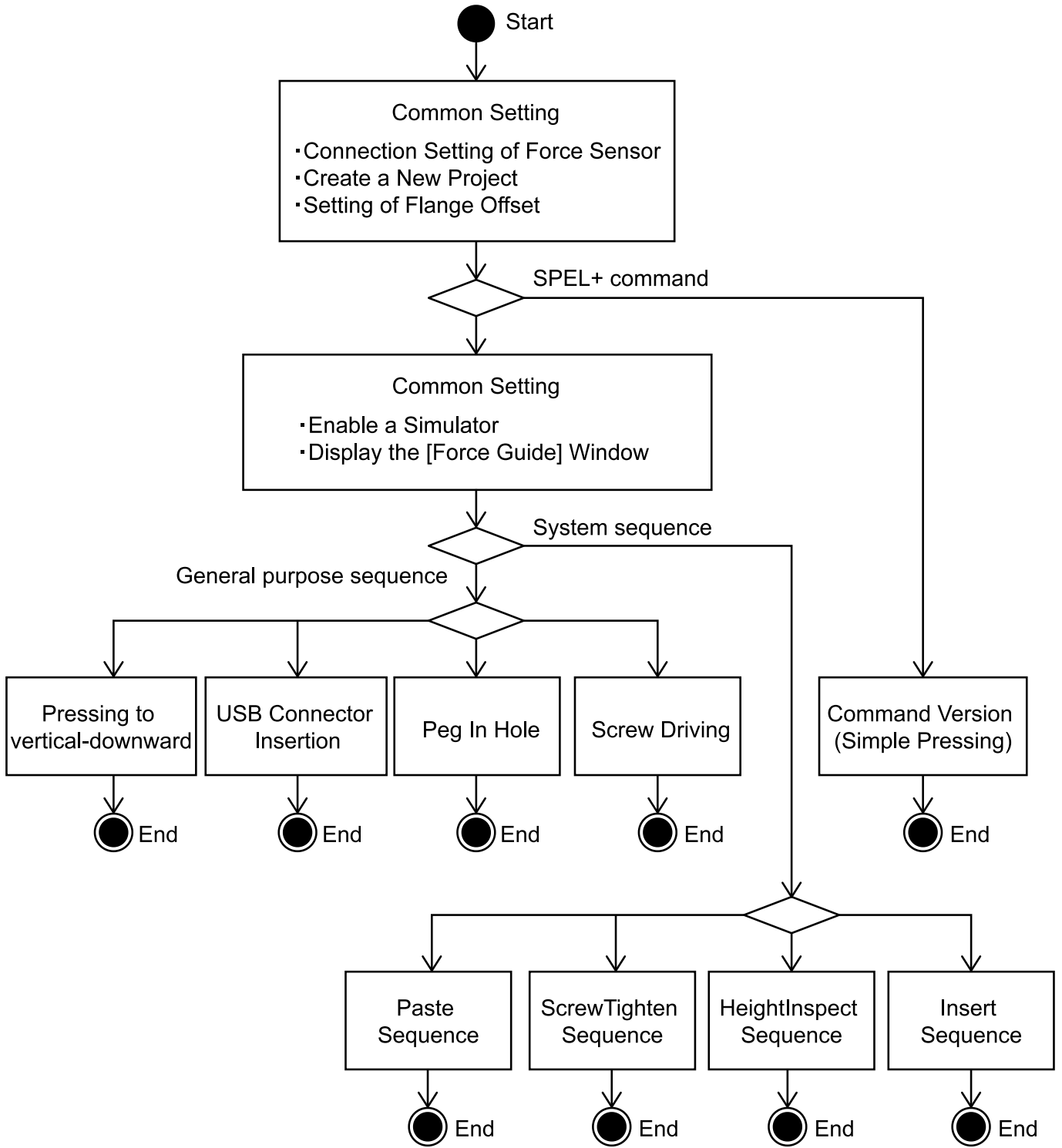

Flow and details of Tutorial

- Force guidance function (General sequence)

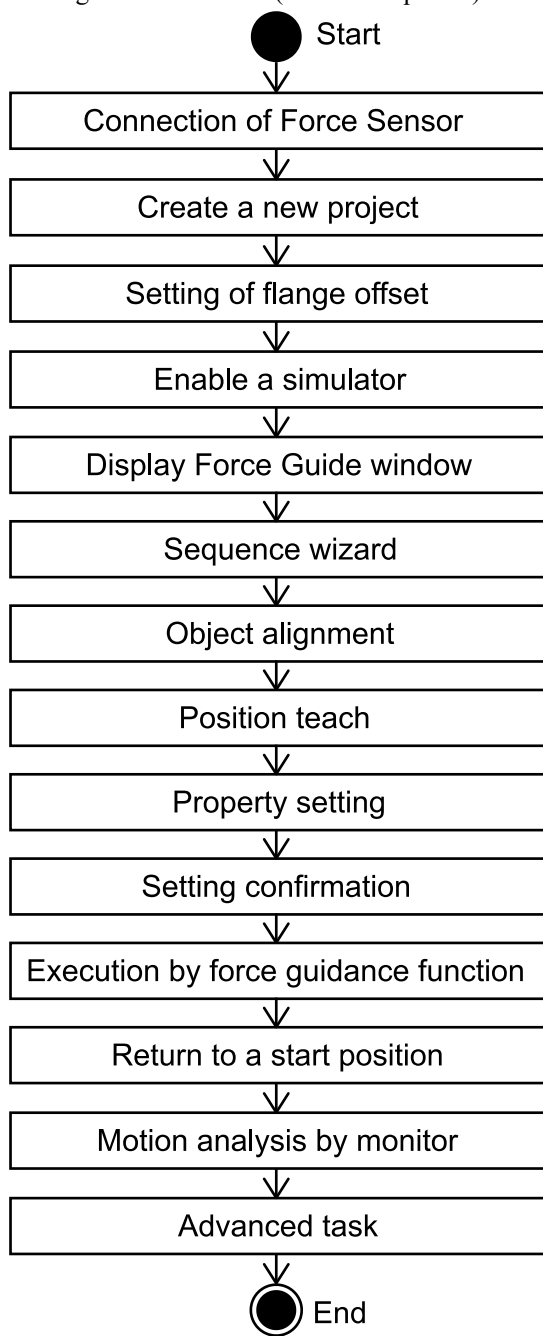

▪ SPEL+ Command function

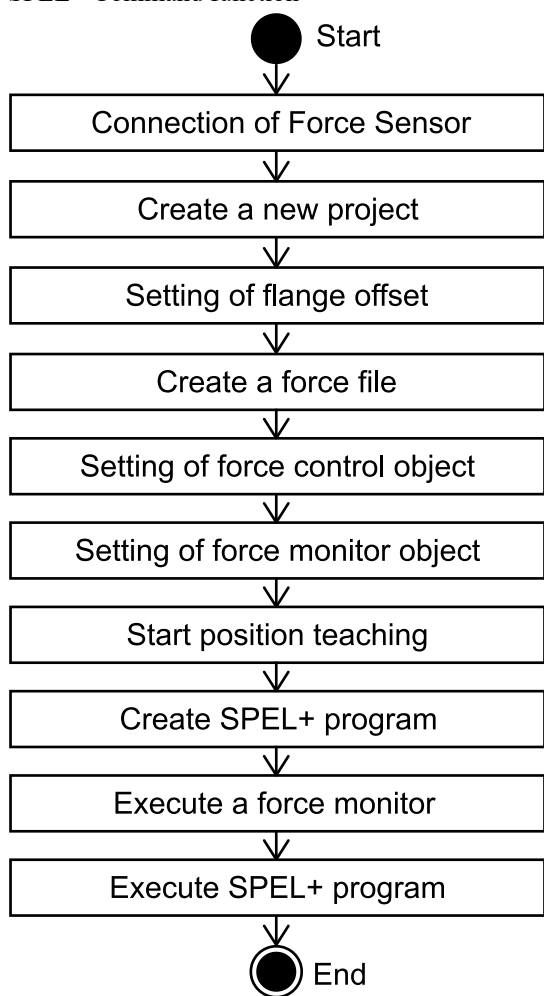

- Force guidance function (System sequence)

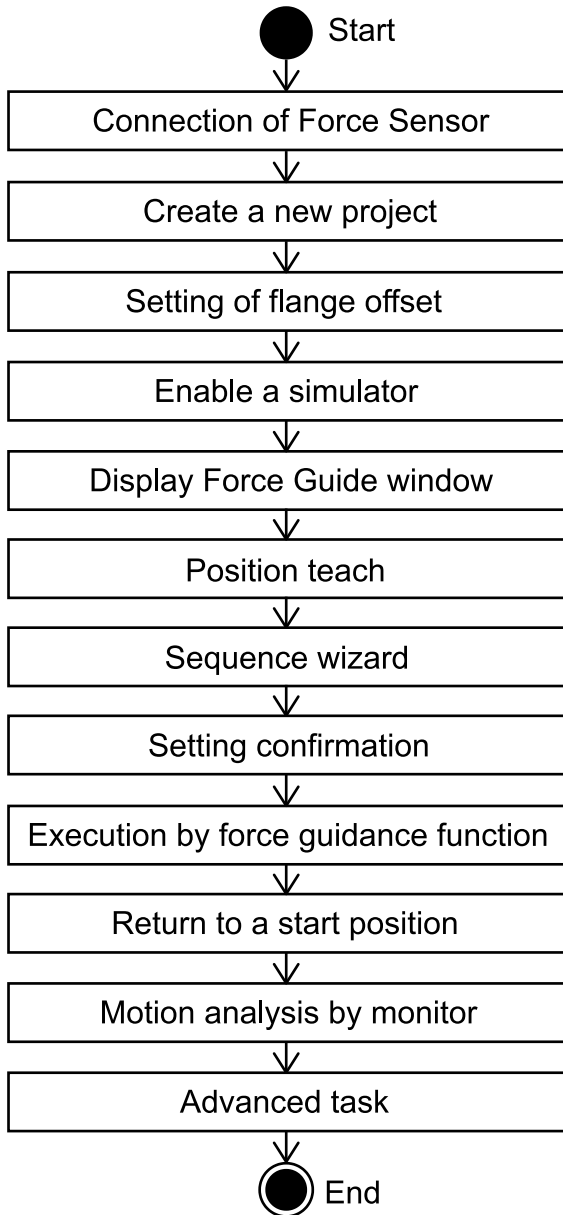

4.6.1 Common Settings

Describe the required settings to use this option by using Epson RC+.

First of all, install a Force Sensor to a robot. Then, refer to the following sections to complete the setting. It is only required when you use this option for the first time. You do not need to set every time.

Connection Settings for the Force Sensor

Create a New Project

Setting the Flange Offset

Enable a Simulator

If the settings above are already completed, refer to the following section and display the [Force Guide] window.

Display the [Force Guide] Window

Then, proceed to the following tutorials:

Force Guidance Function (pressing to vertical-downward)

Force Guidance Function (USB Connector Insertion)

Force Guidance Function (Peg In Hole)

Force Guidance Function (Screw Driving)

Paste Sequence

Screw Tighten Sequence

Height Inspect Sequence

Insert Sequence

Command Version (Simple Pressing)

4.6.1.1 Connection Settings for the Force Sensor

The following describes how to relate the robot that executes the force function with Force Sensor.

1. Select Epson RC+ menu-[Setup]-[System Configuration]-[Controller]-[Force Sensor]-[Sensor 1].

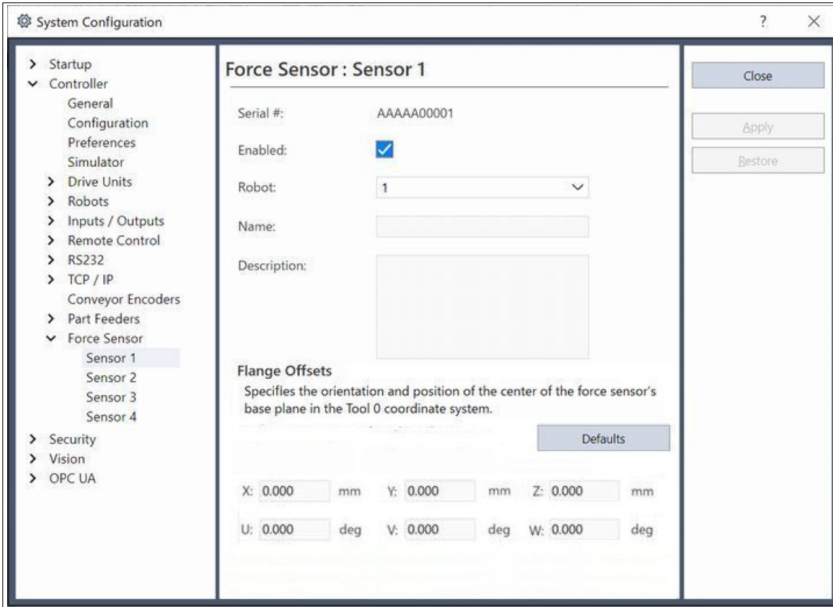

2. Place a checkmark in the [Enabled] check box.
3. Select "1" in [Robot].
4. Wait for the Robot Controller to restart.

4.6.1.2 Create a New Project

The following describes how to create a project that executes force functions.

1. Click Epson RC+ menu-[Project]-[New Project]. The [New Project] dialog box is displayed.

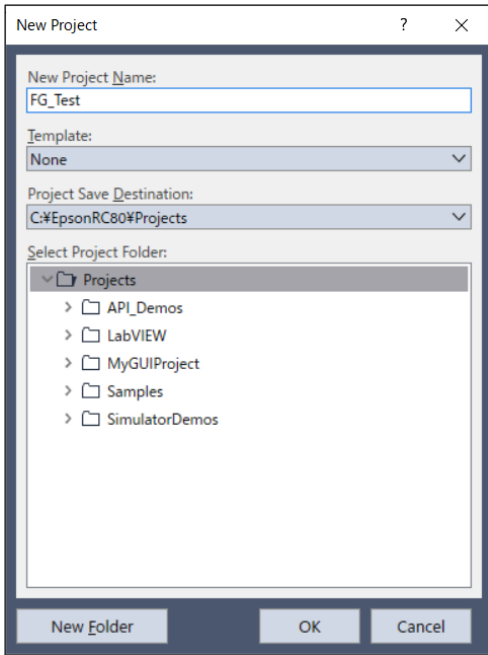

2. Enter "FG_Test" in [New Project Name].
3. Click the [OK] button.

4.6.1.3 Setting the Flange Offset

The following describes how to set the flange offset.

1. Click Epson RC+ menu-[Setup]-[System Configuration]-[Controller]-[Force Sensor]-[Sensor*].

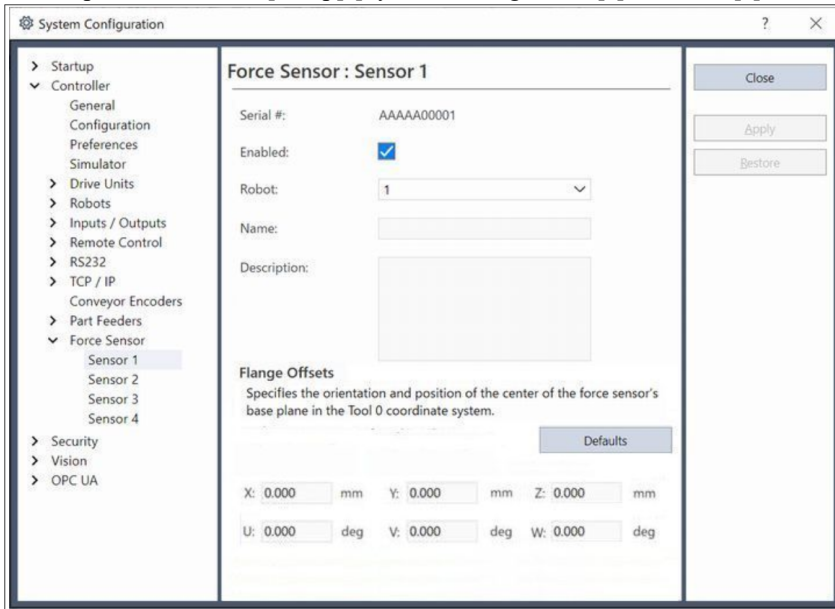

2. Set the flange offset.
When using Epson's sensor flange: Click the [Defaults] button, then click the [Apply] button.

Values are different depending on using Manipulator. Refer to the following section if necessary.
Software [Coordinate Conversion](#)

When using one's own sensor flange:
Enter each value and click the [Apply] button.

Enable a Simulator The sections that follow are settings for the force guidance function.

For SPEL+ command function, go on to the following section:

Command Version (Simple Pressing)

4.6.1.4 Enable a Simulator

The following describes how to enable the simulator function.

1. Click Epson RC+ menu-[Setup]-[System Configuration]. The [System Configuration] dialog box is displayed.

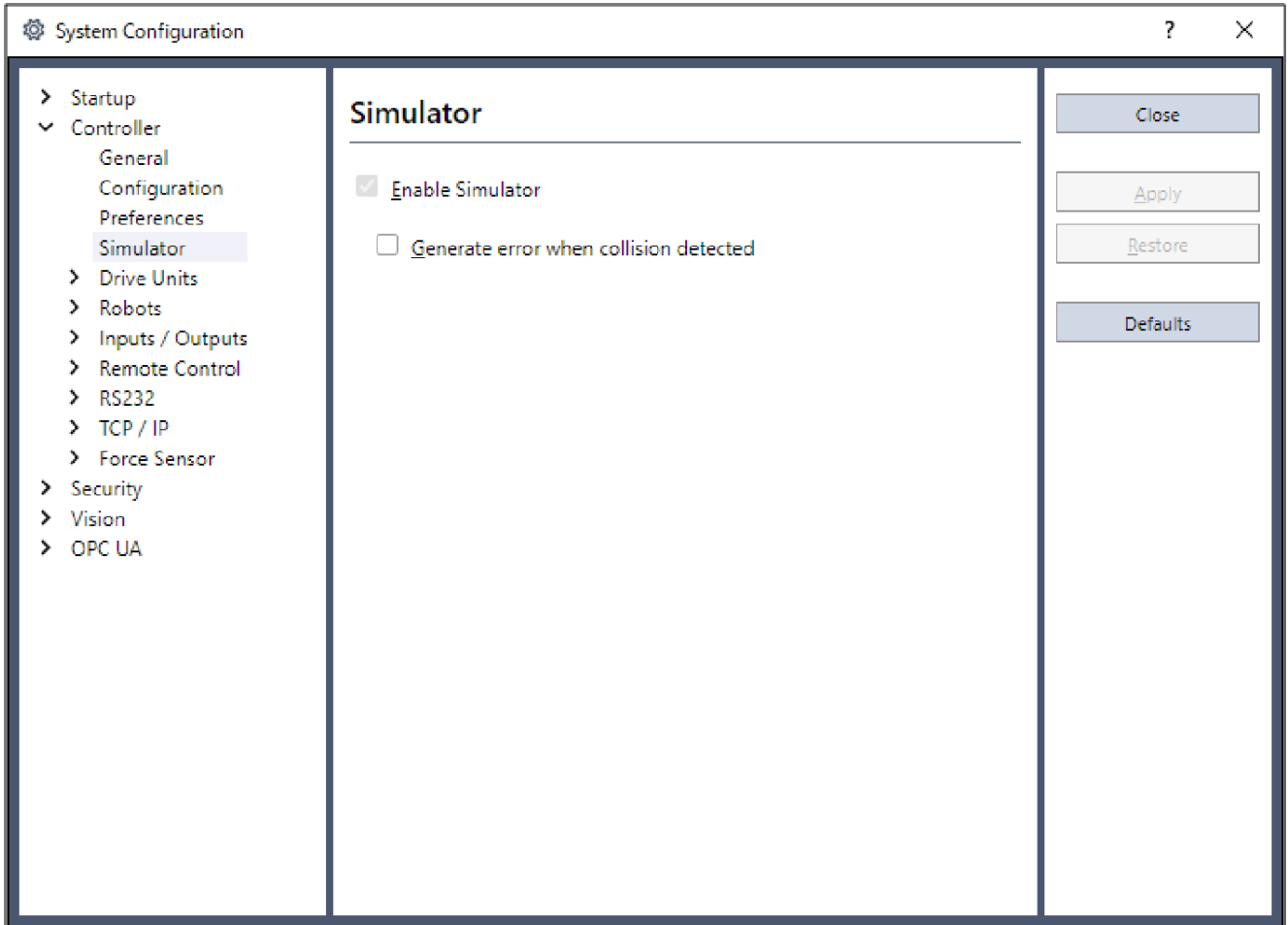

2. Select [Controller]-[Simulator].
3. Place a checkmark in the [Enable Simulator] checkbox.
If already checked, no check is required.
4. Click the [Apply] button.
5. Wait for the Robot Controller to restart.

4.6.1.5 Display the [Force Guide] Window

The following describes how to start the force guidance function.

1. Click Epson RC+ menu-[Tools]-[Force Guide] .
The [Force Guide] window is displayed.

2. Click the [New Sequence ] button.

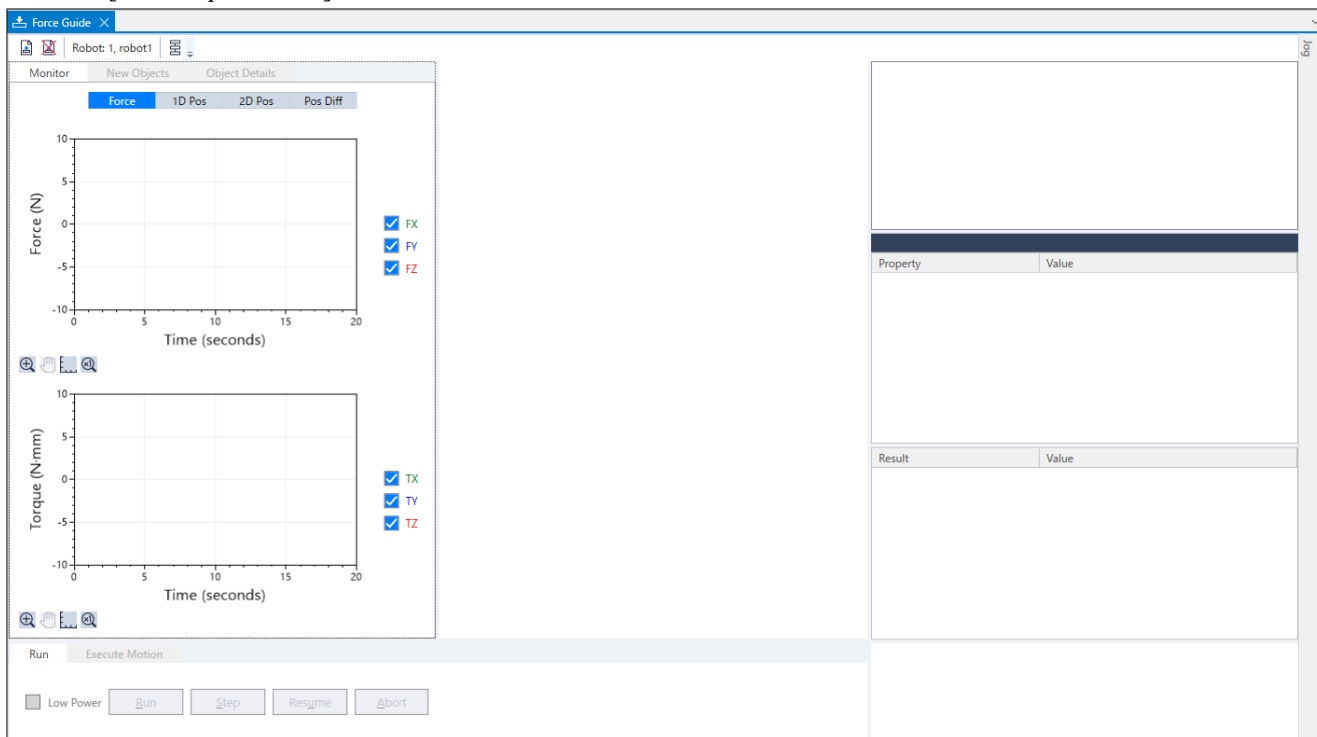

3. The Sequence Wizard is displayed.

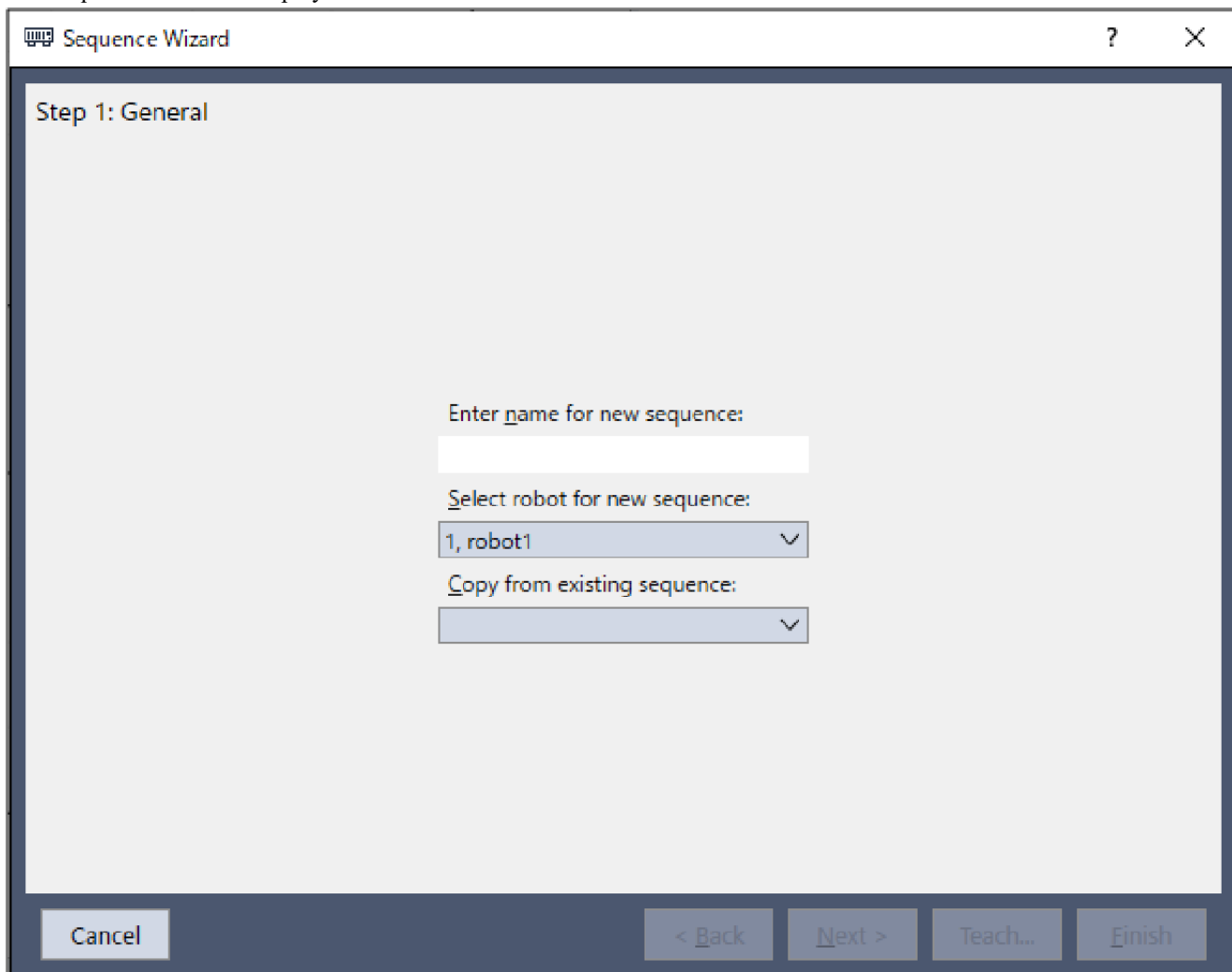

4.6.2 Tutorial Using General Force Guide Sequence

4.6.2.1 Force Guidance Function (pressing to vertical-downward)

As one of the easiest operations, this tutorial describes "pressing" operation to vertical-downward.

If pressing the top plate of Force Sensor to a hard desk or a shape-edged object directly, the plate will get damages or bent. When performing "pressing" operations, be sure to take the following actions:

- Slip a rubber sheet or air cushions in between the "pressing" object and Force Sensor.
- Install a stick shaped end effector for practice.

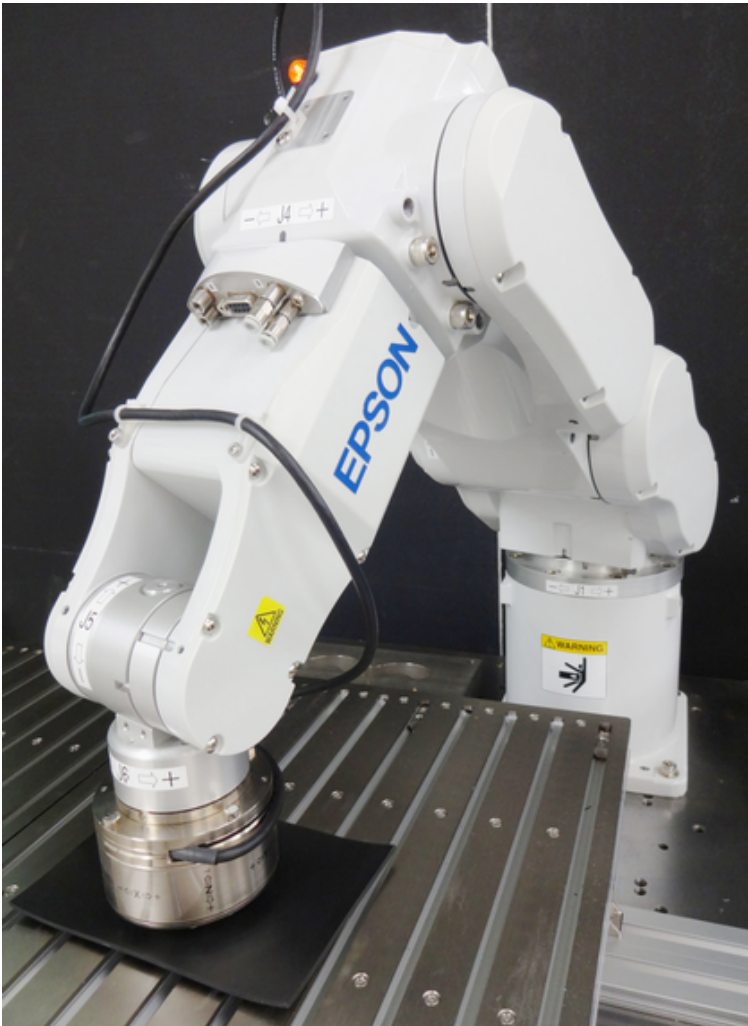

⚠ CAUTION

The parameters described in the example on the following pages are reference values.

This tutorial uses relatively stable parameters, but depending on the operating environment, the operation may not be successful or the motion may be vibratory. Note that adjusting the parameters may be required. Note that Slow, stable parameters are used for convenience of explanation. For high-speed operation, adjusting the parameters is required.

4.6.2.1.1 Sequence wizard

The following describes how to create a force guide sequence that "pressing to vertical-downward".

1. Enter "Press" in the [Enter name for new sequence] box. Click the [Next] button.

Sequence Wizard

Step 1: General

Enter name for new sequence:
Press

Select robot for new sequence:
1, robot1

Copy from existing sequence:

Cancel < Back Next > Teach... Finish

2. The [Step 2: Select sequence type] dialog box is displayed. Select [None]. Click the [Finish] button.

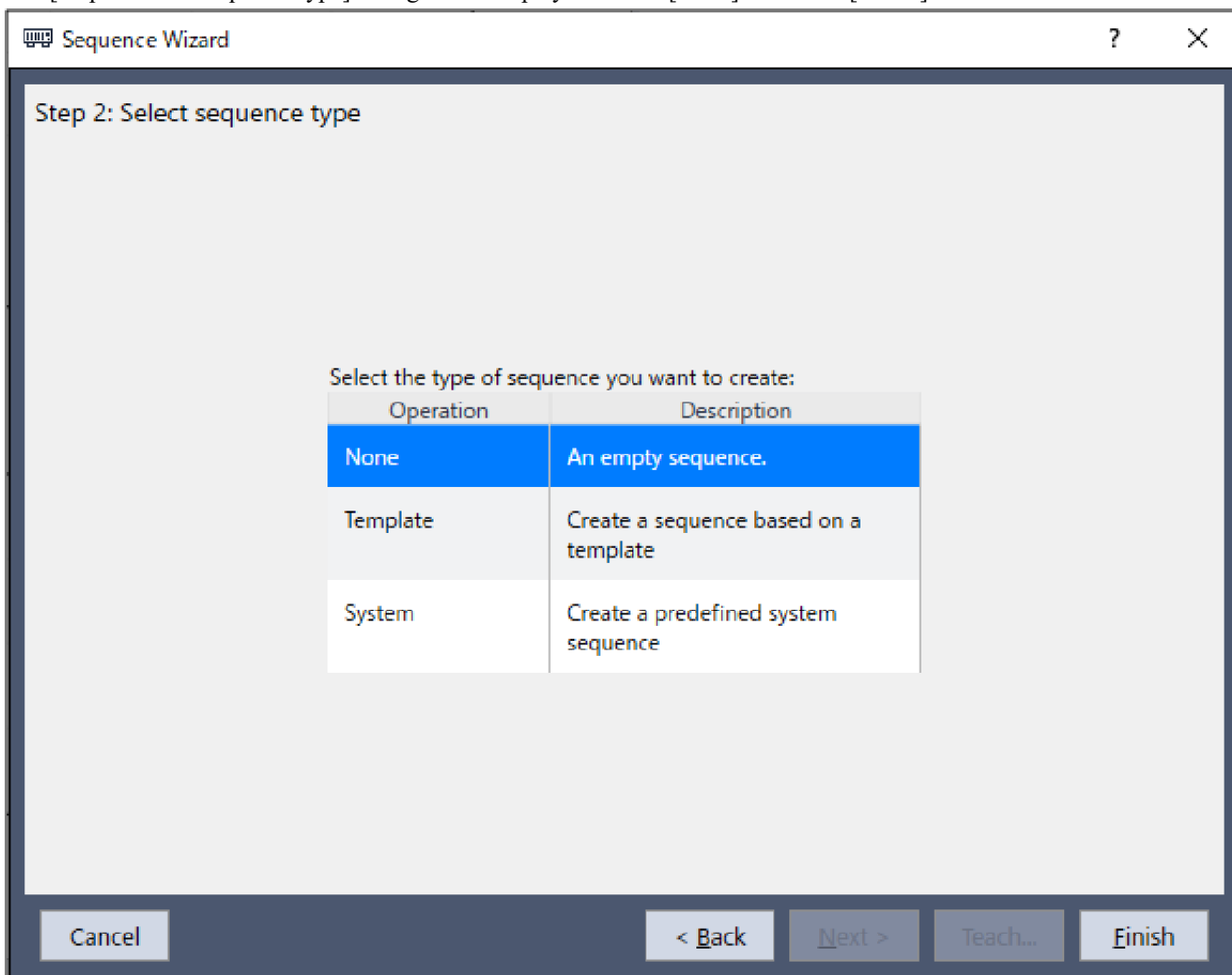

3. Confirm that the [Press] sequence is created.

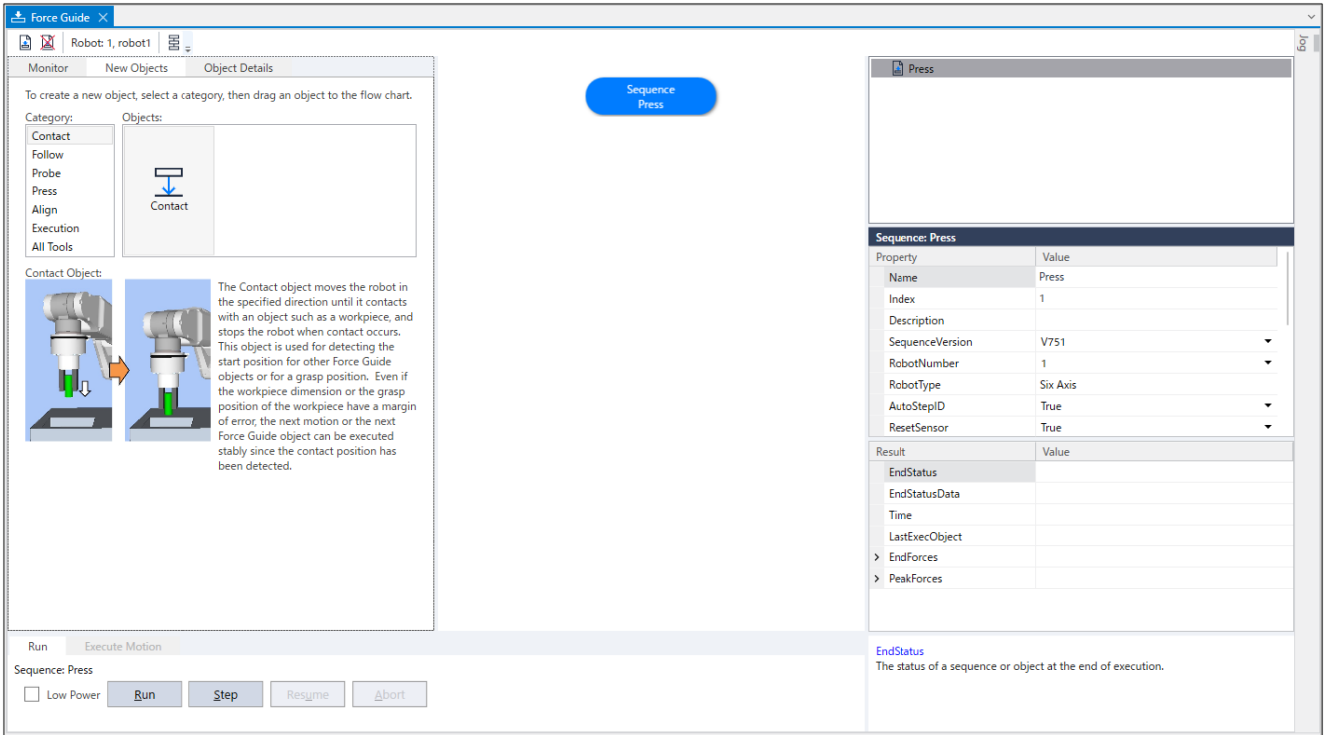

The [Press] sequence is an empty sequence. No objects are aligned. Proceed to the next section.

4.6.2.1.2 Object(s) Alignment

The following describes how to align the force guide objects in the flow chart.

Pressing operations can be performed by using "pressing" object only. However, when improving operation qualities and cycle time, operations will be performed effectively by dividing "contacting operation" from "pressing operation".

In this tutorial, divide "contact" from "press" and create a force guide sequence.

1. Select the [Force Guide] window-[New Objects] tab. Select "Contact" in [Category]. Click [Objects]-[Contact] icon. Description is displayed on the lower half of the window. Drag the [Contact] icon to the flow chart.

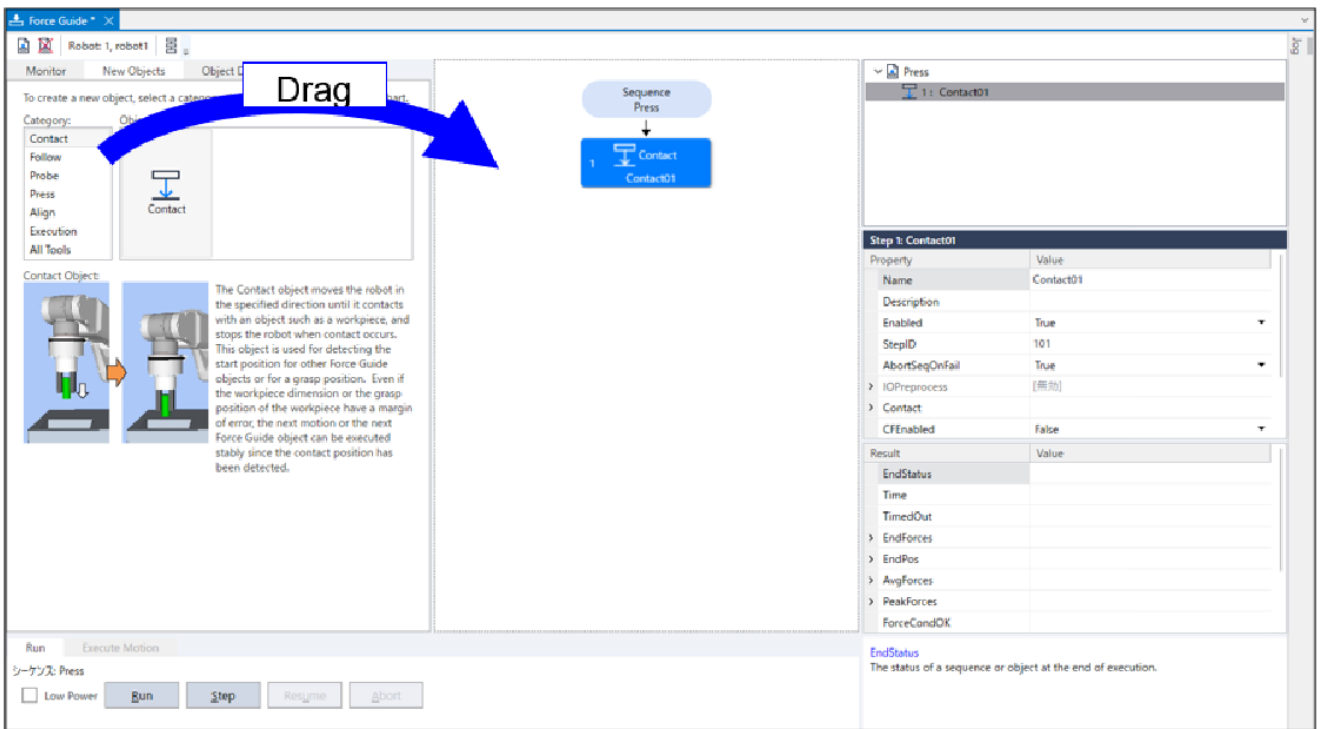

The "Contact" object is registered as [Contact01] object.

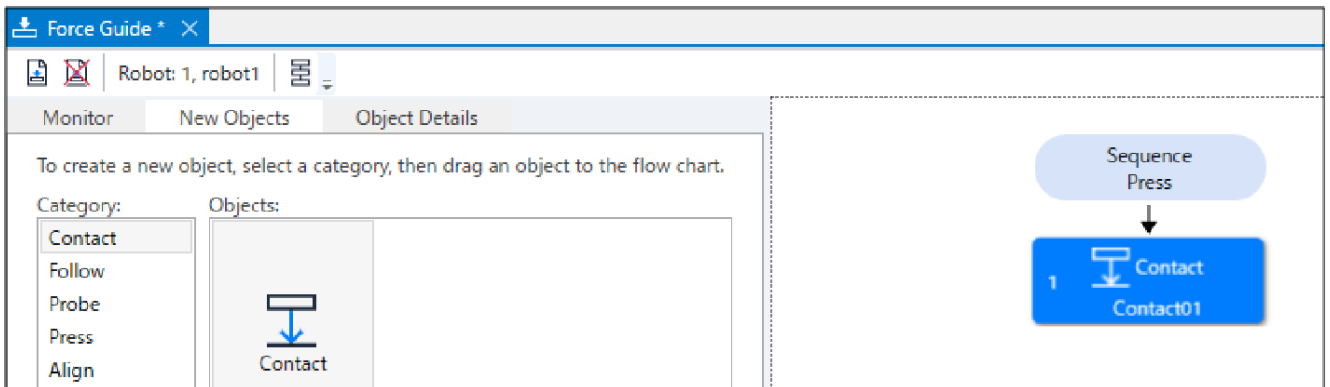

2. Select "Press" in [Category]. Drag the [Objects]-[Press] icon to the flow chart.

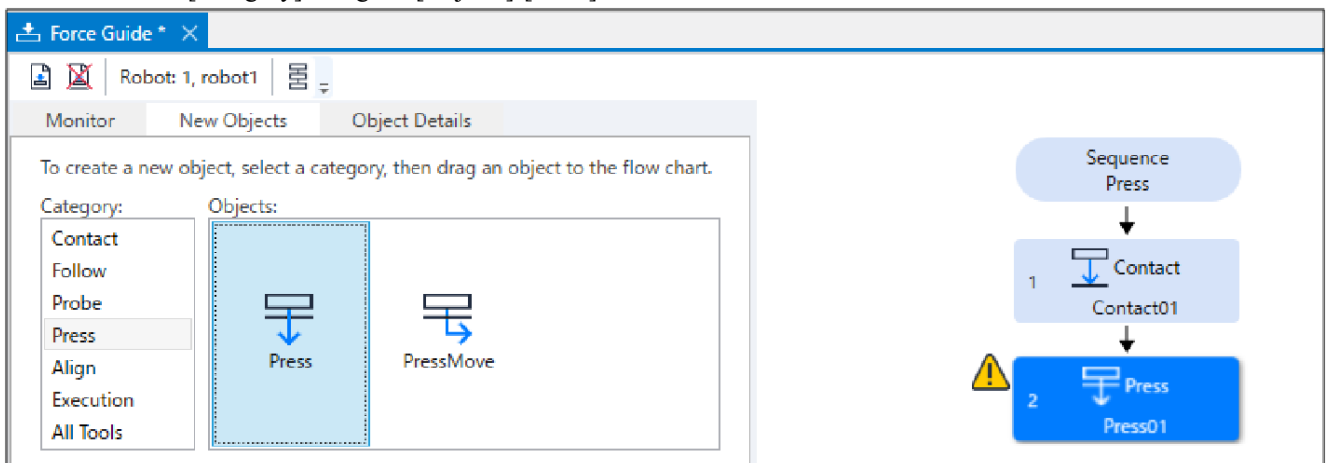

The "Press" object is registered as [Press01] object.

Now, object settings have completed. Next section describes property setting.

4.6.2.1.3 Property Setting

The following describes how to set the required properties for pressing operations.
 Values are as follows:

Threshold to end a contact object	4 [N]
Pressing force	4 [N]
Pressing time	1.0 [s]

1. The  mark is displayed on the flow chart by default. You need to set properties.



Move the mouse pointer onto the  mark to display the tool tips. The tool tips show settings or content which need to be modified.

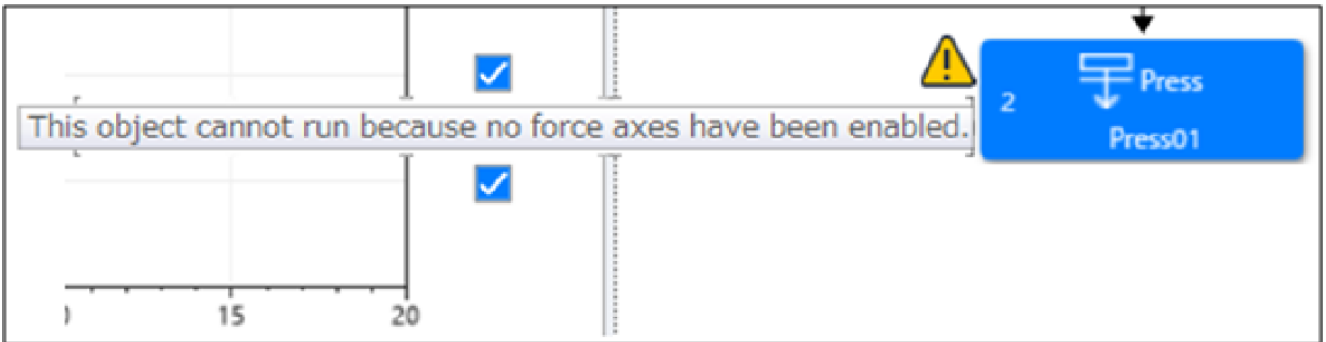

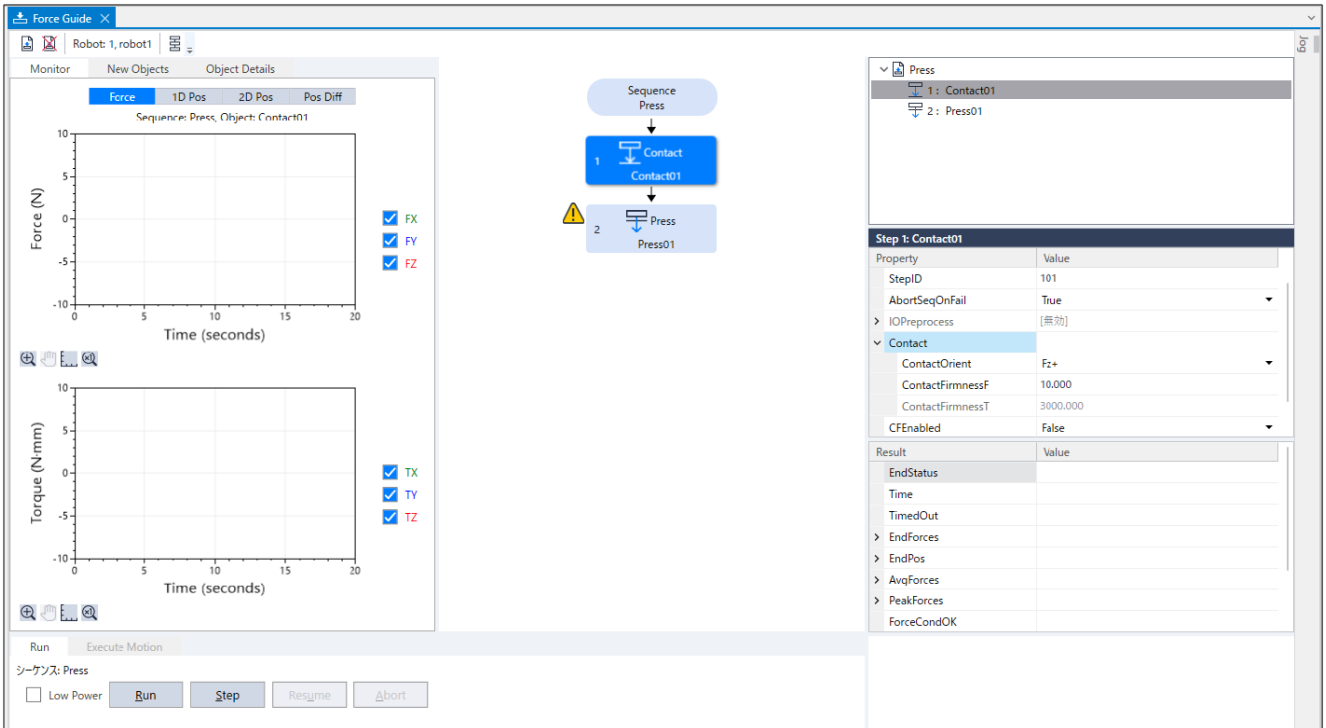

2. Click the [Contact01] object in the flow chart. Properties and Results are displayed.



3. Confirm that the value of the [Contact]-[Orient] property is "+Fz".
 Contacting direction is the same as "+Fz" direction of tool setting. It is set as "downward pressing" of 6-axis robot. At this time, only a negative (-) value can be entered to value of [ContactForceThresh] property.

"Pressing" direction is set depending on the direction of the tool setting. In 6-axis and SCARA robots, when the mounting type is standard (floor mounting), tool settings for the sensor top plate will be opposite. Set as shown below.

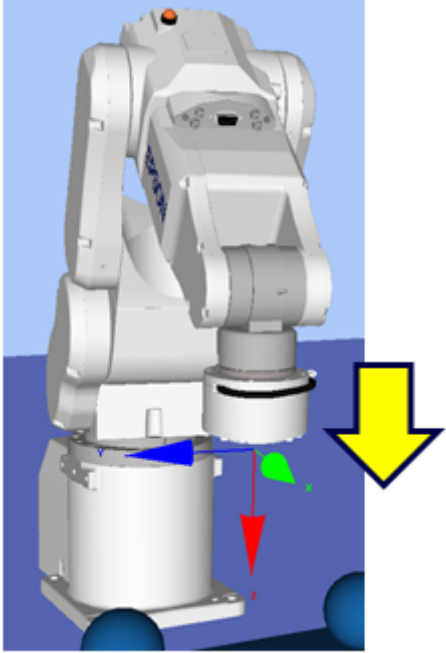
Reference

	6-axis robot	SCARA robot
Robot motion image Pressing		
(Press/Contact) Orient	+Fz	-Fz
Sign of Force (monitor display is included)	-	+

4. Change the [Contact01] object's properties.

You do not need to change items that are not shown in the following list. Click on each item to display its property overview or setting range in the Quick Help column in the bottom right.

For details on the setting items, refer to the following section:

Software **Contact Object**

Item	Value	Description
ContactOrient	+Fz	Set a direction to contact. The robot moves to the specified direction.
ContactFirmnessF	2	Set a firmness of the force control functions.
		When setting a large value: The Force Control functions become stronger, but response to changes in force is slow.
		When setting a small value: The Force Control function will become weaker. Response to changes in force is fast; however, vibrations can easily occur.
		When setting a small absolute value: Movement speed of the contact motion will be fast.
		Set a limit of speed advancement without damaging the workpiece or robot by yourself.

Item	Value	Description
Force End Conditions - ContactForceThresh	-4	Threshold to decide a contacting force. Absolute value of the force in the Fz direction exceeds that of ContactForceThresh in the specified time of Timeout. Approach speed to an object affects the force when the robot contacts with the object completely. Be sure to consider the possibility that the payload is applied to the workpiece or robot due to overshoot.
Timeout	10	If the end condition has not satisfied in 10 seconds, an error occurs. It can prevent an unintended motion such as a target of contact detection is far or a motion with improper setting.

5. Click the [Press01] object in the flow chart.

Properties are displayed.

Step 2: Press01	
Property	Value
▼ Fz	
Fz_ControlMode	Press+
Fz_PressForce	-4.000
Fz_Firmness	2.000
> Tx	Disabled
> Ty	Disabled
> Tz	Disabled
CFFEnabled	False
EndCheckOperator	AND
> ForceEndConditions	
> PosEndConditions	
> IOEndConditions	[Disabled]
Timeout	1.000 sec

6. Change the [Press01] object's properties. You do not need to change items that are not shown in the following list. Click on each item to display its property overview or setting range in the Quick Help column in the bottom right.

Item	Value	Description
FzControlMode	Press+	Mode of the force control functions to Fz direction. Press+: The robot moves to a positive direction of each axis and presses.
Fz - Force	-4	Set a pressing force . (negative value) For fittings or assembly tasts, the force is usually set from 3 to 5[N] or from -3 to -5[N] in Fx, Fy, and Fz. However, a proper value differs depending on tasks or workpiece.
Fz - Firmness	2	Set a firmness of the force control functions in Fz direction.
		When setting a large value: The Force Control functions become stronger, but response to changes in force is slow.

Item	Value	Description
		When setting a small value: The Force Control function will become weaker. Response to changes in force is fast; however, vibrations can easily occur.
Timeout	1	Set the time-out duration. It is not the duration after the force reaches the [PressForce] but duration for the pressing force control.

7. Click Epson RC+ menu-[File]-[Save File]. Modified properties are saved to the project.

4.6.2.1.4 Position Teaching

The following describes how to teach a start point of "pressing" motion.

1. Click Epson RC+ menu-[Tools]-[Robot Manager].
The [Robot Manager] dialog box appears.
2. Select the [Jog & Teach] tab.

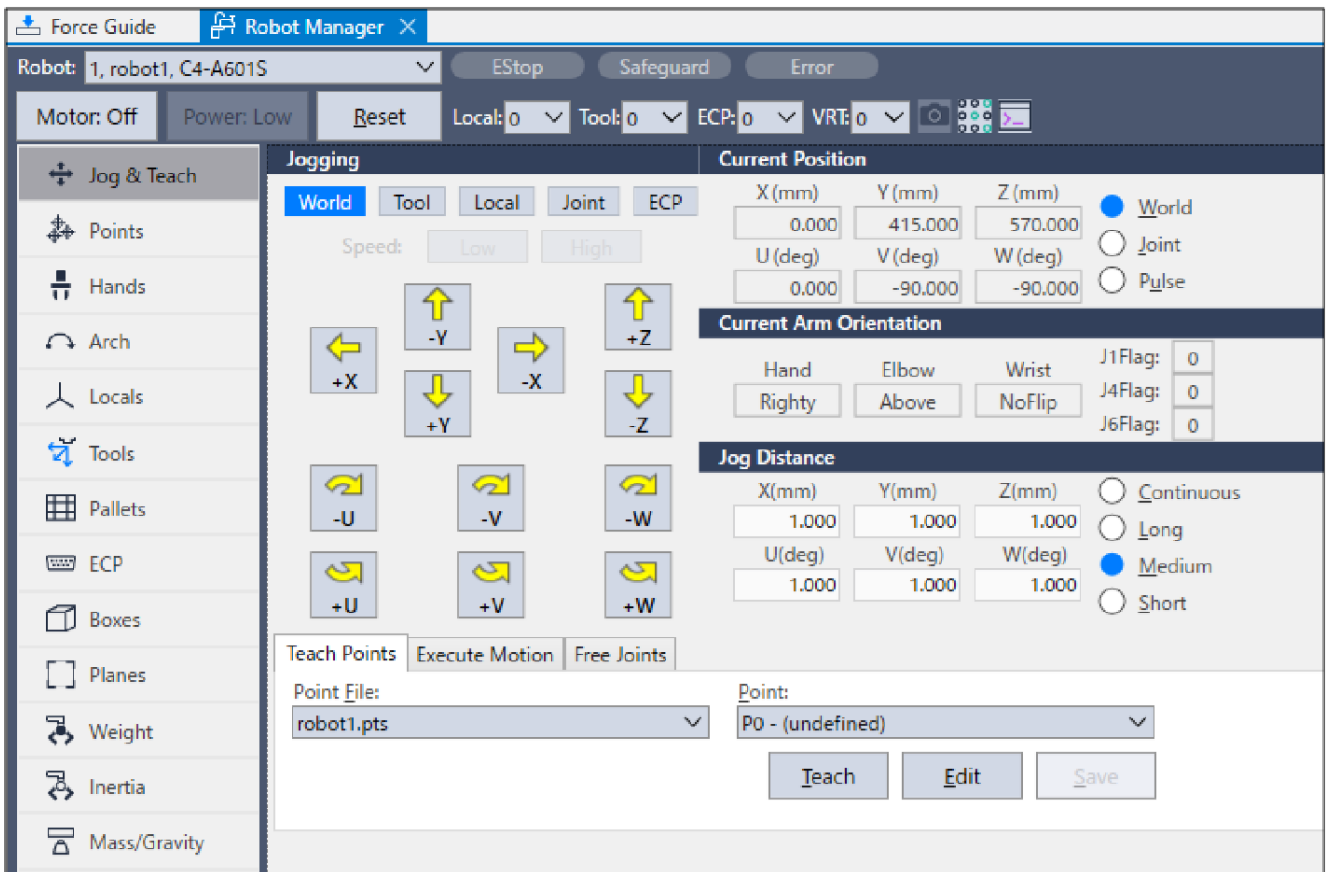

3. Click the Jog button and move the robot to 3mm above the target object to be pressed.

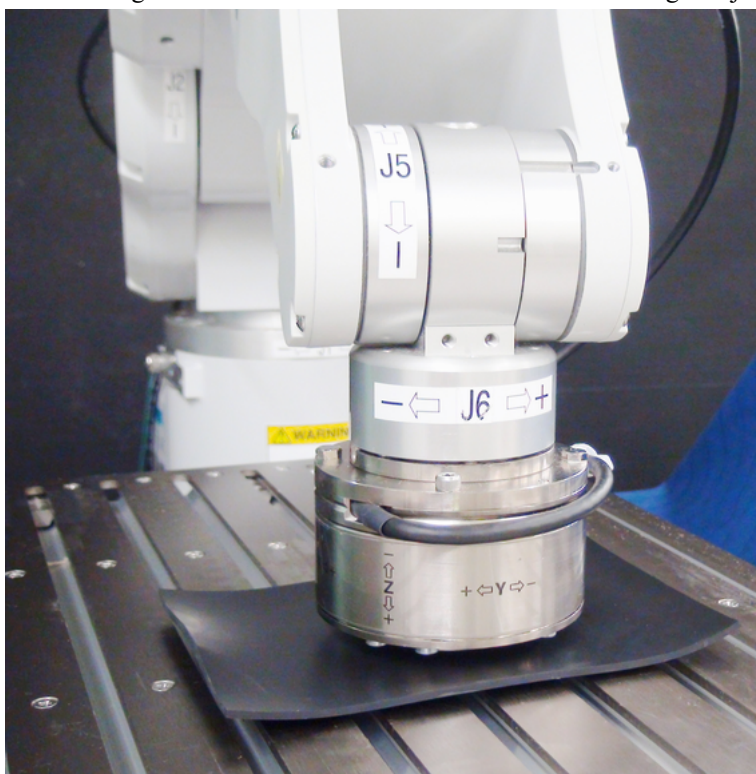

4. Select "P1" in the [Point] dropdown.

5. Click the [Teach] button.

The following message is displayed. Confirm the message and click the [Yes] button.

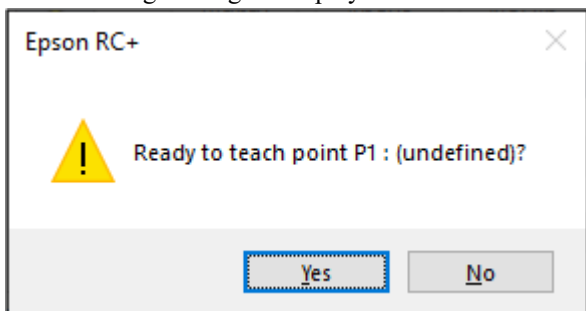

6. The [New Point Information] dialog box is displayed. Enter "Test_P1" in [Point Label] and then click the [OK] button.

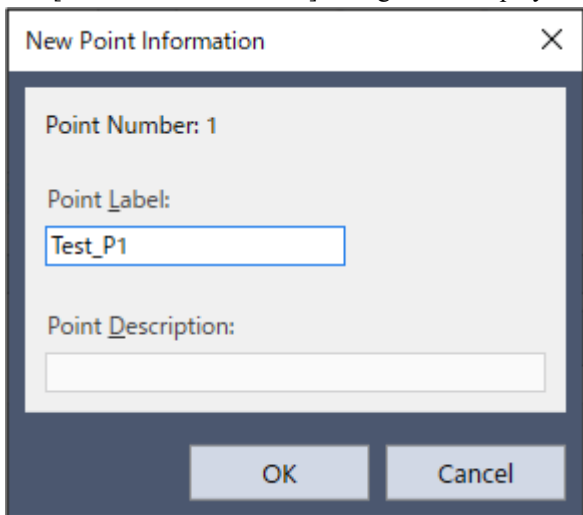

7. Click Epson RC+ menu-[File]-[Save All]. Set contents will be saved in the file.

4.6.2.1.5 Setting Confirmation

The following describes how to check whether the setting of "pressing" direction is correct by using simulator.

1. Click Epson RC+ menu-[Tools]-[Simulator]. The [Simulator] window is displayed.
2. Click the object tree-[Layout]-[robot1]-[Tool].
3. Place a checkmark in "No.0"-[Visible] check box. An arrow for "Tool 0" is displayed.
4. Click the object tree-[Layout]-[robot1]-[Force Sensor].
5. Set the [Transparent] property to "True". The arrow origin of the "Tool 0" is displayed.

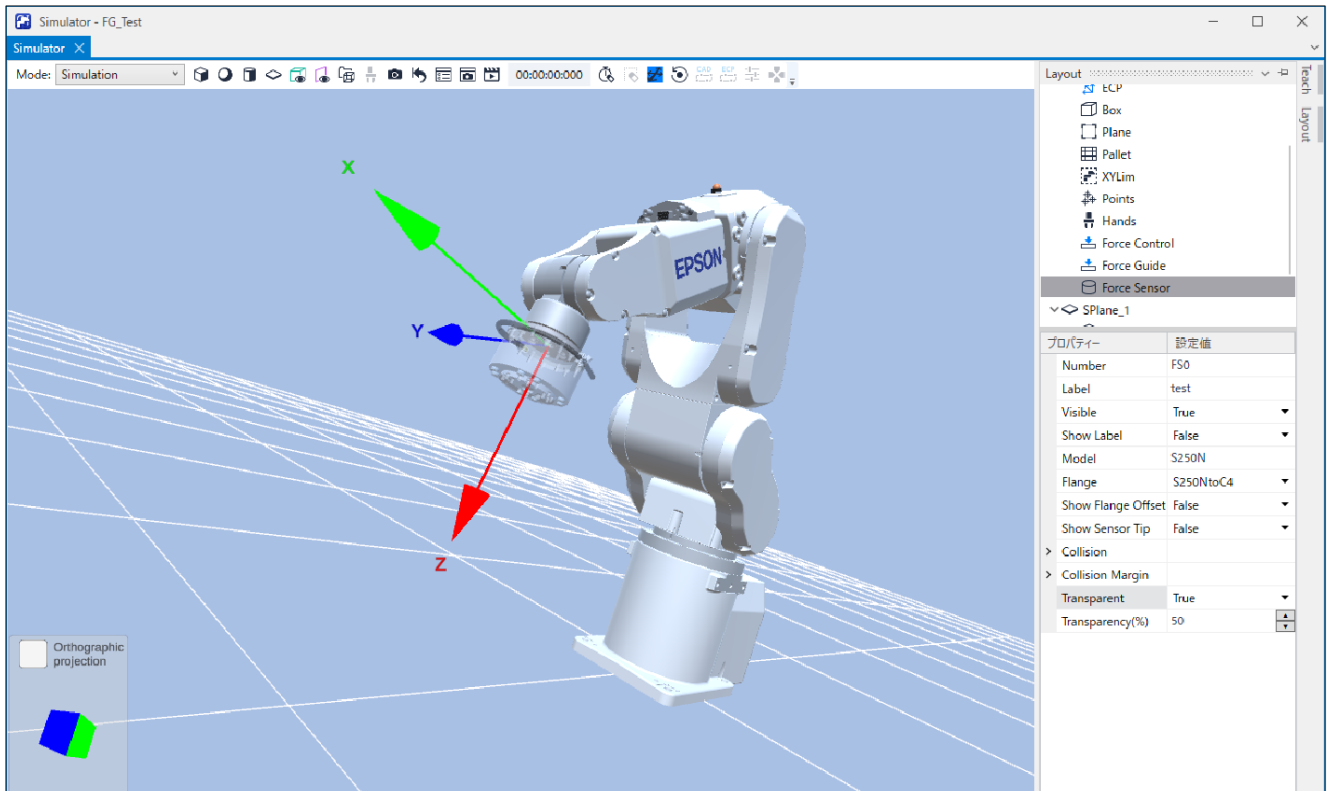

6. Place a checkmark in "No.0"-[Visible] check box. The arrow of "Tool 0" will be hidden.
7. Select the object tree-[Layout]-[robot1]-[Force Guide]-[Press]. Place a check mark in "Contact01" and "Press01"-[Visible] check boxes. Yellow arrow is displayed in a motion direction of the Contact and Press objects. If the arrow direction is not downward, the following setting is improper. Refer to the reference of the guidance function to change the setting.

Software **Property Setting**

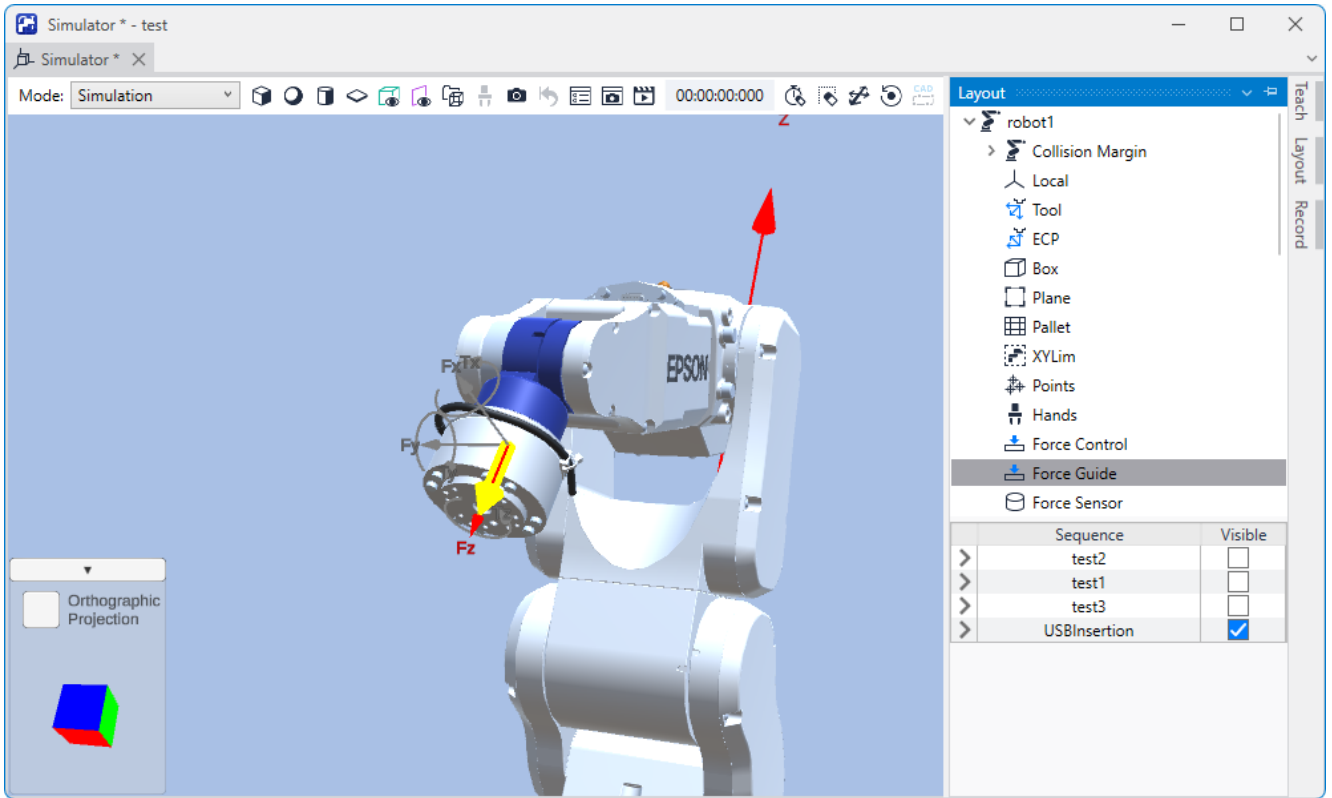

4.6.2.1.6 Motion by Force Guidance Function

The following describes how to run a force guide sequence that performs "pressing" operations by Epson RC+.

1. Open the [Force Guide] window.

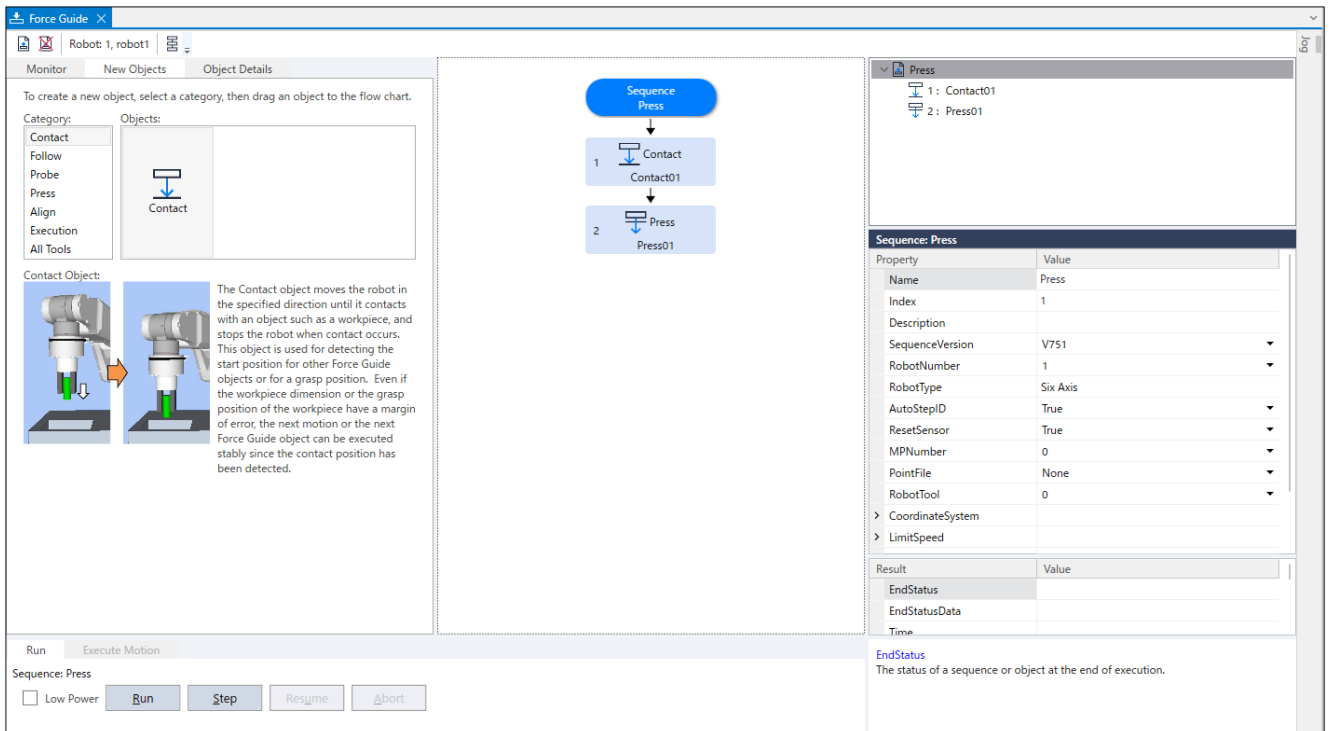

2. Click the [Run] button. Compilation is executed. Program is transmitted to the Robot Controller. If the setting is not correct, an error occurs. If the error occurs, check the settings so far and modify the parameters according to the error message.

4.6.2.1.7 Return to the Non-Contact State

The following describes how to return to the non-contact state.

Force continues to be applied to between the robot and the pressing target object even the "pressing" operation has completed. To prevent the robot and the end effector from malfunction or damage, move the robot away from the object immediately after the operation ends, and make sure that no force is applied to the object. If it is obvious that no force is applied to the object, you can omit this step.

Steps to return to non-contact state are as follows:

- Click Epson RC+ menu-[Tools]-[Robot Manager]-[Jog & Teach] panel-[Jog] group and perform jog motion manually to move the robot away from the object.
- Click Epson RC+ menu-[Tools]-[Robot Manager]-[Jog & Teach] panel-[Execute Motion] tab and move the robot away from the object.
- Execute Move command on [Command Window] and move the robot away from the object.
- Add SPELFunc object after Press object, and automatically move the robot away from the object at the end of the force guide sequence.

This section describes how to set the robot to the non-contact state by clicking [Robot Manager]-[Jog & Teach].

1. Display the [Robot Manager] dialog box.
2. Click the [Jog & Teach] tab.
3. Select the [Execute Motion] tab.
4. Select "Move" in [Command].
5. Select "P1" in [Destination].
6. Click the [Execute] button.

The robot moves to the start point: P1. Now, it is the non-contact state.

[Reference]

In the upper-right of the [Force Guide] window is the [Jog] tab.

When you select the [Jog] tab, the [Jog] window is displayed. The robot will move and be set to non-contact state by clicking the Jog button or entering value.

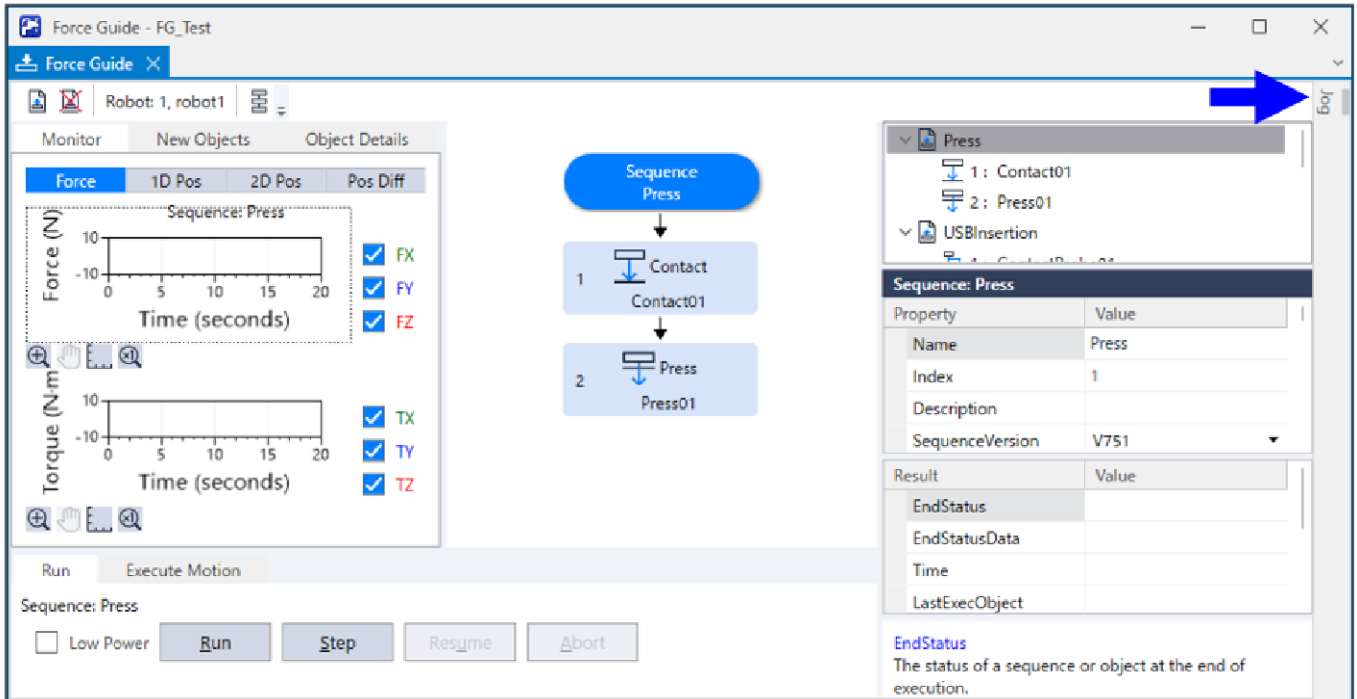

4.6.2.1.8 Motion Analysis by Monitor

The following describes how to use Epson RC+ to check the operation results of a force guide sequence.

1. Open the [Force Guide] window.

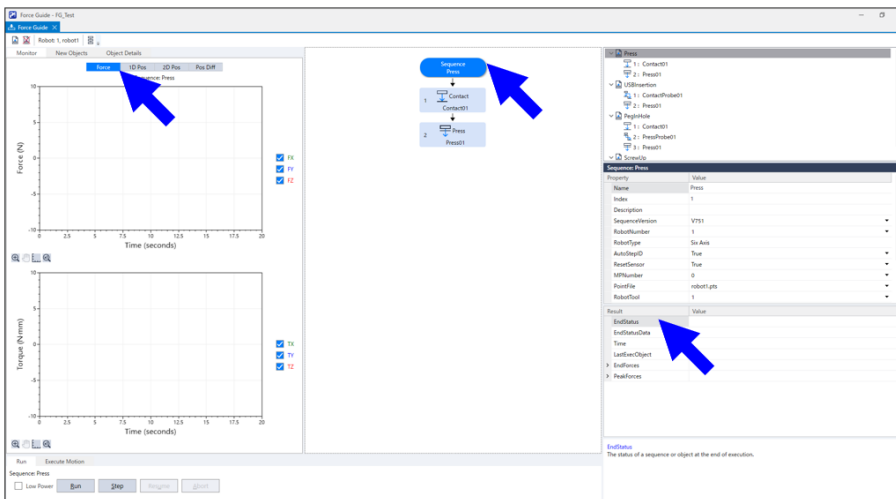

2. Click the sequence flow of [Press].
3. The operation results (Passed / Failed), detected force values at the end of the robot motion, and the time that was required are displayed under [Result].

■ [Monitor] tab

Force and position during the [Press] sequence execution are displayed in the graph. Click the object flows of [Step1] and [Step2] to display the force and the position during the execution of the selected force guide object.

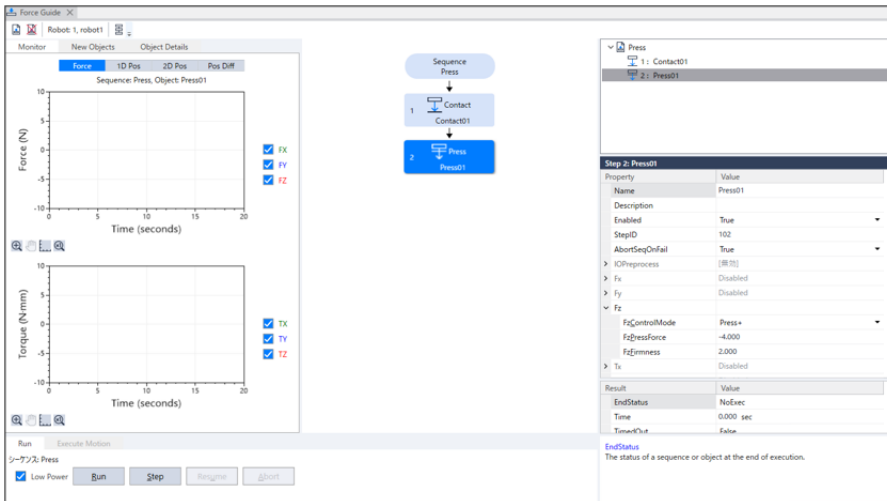

■ [1D Pos] tab

It is a graph for analysis. (horizontal axis: Time, vertical axis: Position) The robot moves to direction where CurZ of the position Z chart is getting low (small). Since the "Step 1" ends near 3.4 seconds and the force control has been completed, you can see that the value of RefZ (reference position) is falling (jumping) straight down to CurZ (current position).

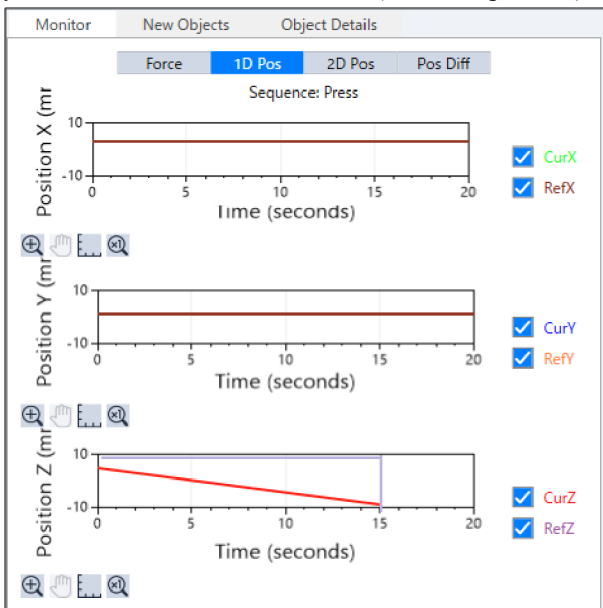

■ [2D Pos] tab

It is a graph for analysis. (horizontal axis, vertical axis: Position) It is not required for simple pressing operation to Z direction since the robot does not move to X-Y directions. Execute the following and check the graph. Software "3" in [Advanced Tasks](#)

■ [Pos Diff] tab

It shows the relative change of positions due to the force control. Change the unit of the graph and check the changes of force or positions.

4.6.2.1.9 Advanced Tasks

Let's do the following advanced tasks.

1. First of all, set the pressing force to 1 [N] for 3 seconds. Next, execute a continuous motion that increases the force to 10 [N] over another 3 seconds. Tip: You need to add objects. Three objects in total are required.
2. Set the properties of the force guide sequence as follows, and record the log. In default setting, it is recorded in the same folder as the projects under development in csv format. Open the file in spreadsheet software and create a graph.

	Item	Value	Description
Log	RobotLocal	Base	For the positional orientation of the robot that is recorded during the force guide sequence execution, set a reference local coordinate system number.
			Set Base coordinate system to record the robot positions.
	FileEnabled	True	Set whether to save in a file.
			Enable the log creation.
	FileAutoName	True	Set whether to automatically set a file name to be recorded.
	Interval	0.05	Set a sampling period for the files to be recorded.
Set the recording interval to 0.05 seconds.			

The screenshot displays the software interface for configuring a force guide sequence. On the left, a sequence diagram shows a 'Sequence Press' block leading to two steps: '1 Contact Contact01' and '2 Press Press01'. On the right, the configuration panel for the 'Press' sequence is shown. The 'Log' section is expanded, revealing the following settings:

Property	Value
LogRobotLocal	Base
LogFileEnabled	False
LogFileAutoName	True
LogFileNameVar	False
LogFileInterval	0.200 sec

Below the settings, a 'Result' table is visible with columns for 'Result' and 'Value'. The 'Result' table includes the following rows:

Result	Value
EndStatus	
EndStatusData	
Time	
LastExecObject	
> EndForces	
> PeakForces	

At the bottom of the configuration panel, there is a description for the 'LogFileEnabled' property: **LogFileEnabled** Enables logging data to a file for the sequence.

3. Set Follow in the X and Y axis directions, and make sure to perform "pressing" in the Z direction only. Tip: X and Y axis perform a follow motion by selecting "Follow".

By setting the tool setting to the center of the contact position, you can assume a tilt of a contact plane or a contact position by torque, or perform the follow motion along the plane.

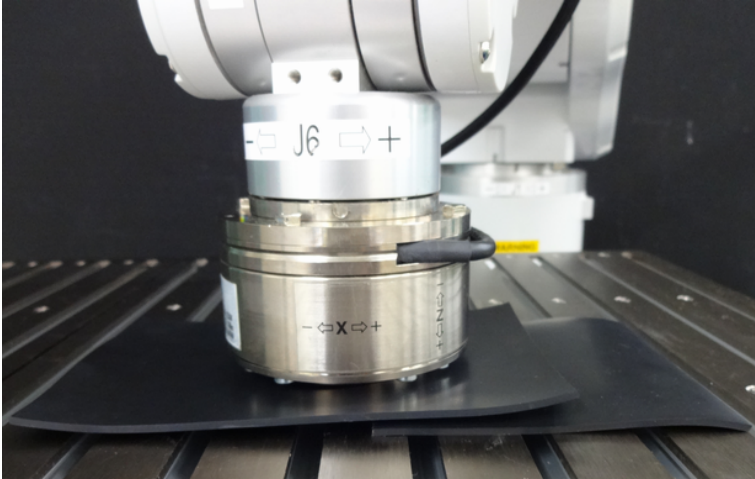

i. When only the Force Sensor is installed on a C4 series Manipulator, the center thickness of the contact position is 49mm.

Set Tool 1 and select it.

Execute the following by command window.

```
> TLSet 1, XY(0, 0, 49, 0, 0, 0)
> Tool 1
```

ii. Click the Force Guide window's [Run] button. The following error occurs.

The following error occurs.

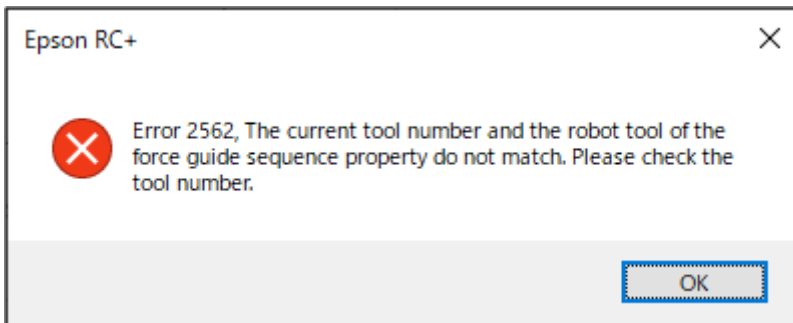

iii. Display the properties of the [Press] sequence.

Select "1" in [RobotTool].

Sequence: Press	
Property	Value
AutoStepID	True
ResetSensor	True
MPNumber	0
PointFile	robot1.pts
RobotTool	1
CoordinateSystem	

If tool settings are not configured properly, the robot's motions may not be carried out properly, and the end effector or workpiece may get damaged. This error occurs to prevent these problems.

iv. Since the tool setting was changed, the actual arm joint angle of the robot is different even though the same point data was used.

Refer to the following to re-teach the teaching positions.

Software **Position Teaching**

- v. Different torque values corresponding to "Tool 0" and "Tool 1" are detected.
(See the following figure). Translational force value is the same.

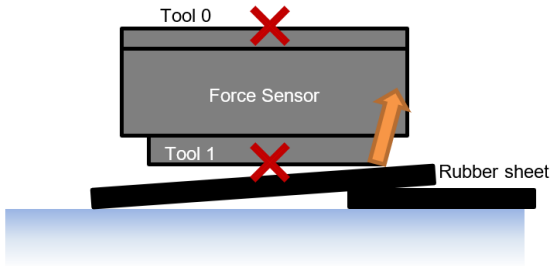

Torque is calculated by multiplying the force by the distance from the contact position, as viewed from the origin of the force coordinate system (normally, this matches the Tool coordinate system). As shown below, waveforms of translational force are the same. However, waveforms of torque differ depending on the distance from the contact position, and "Tool 0" can measure larger values.

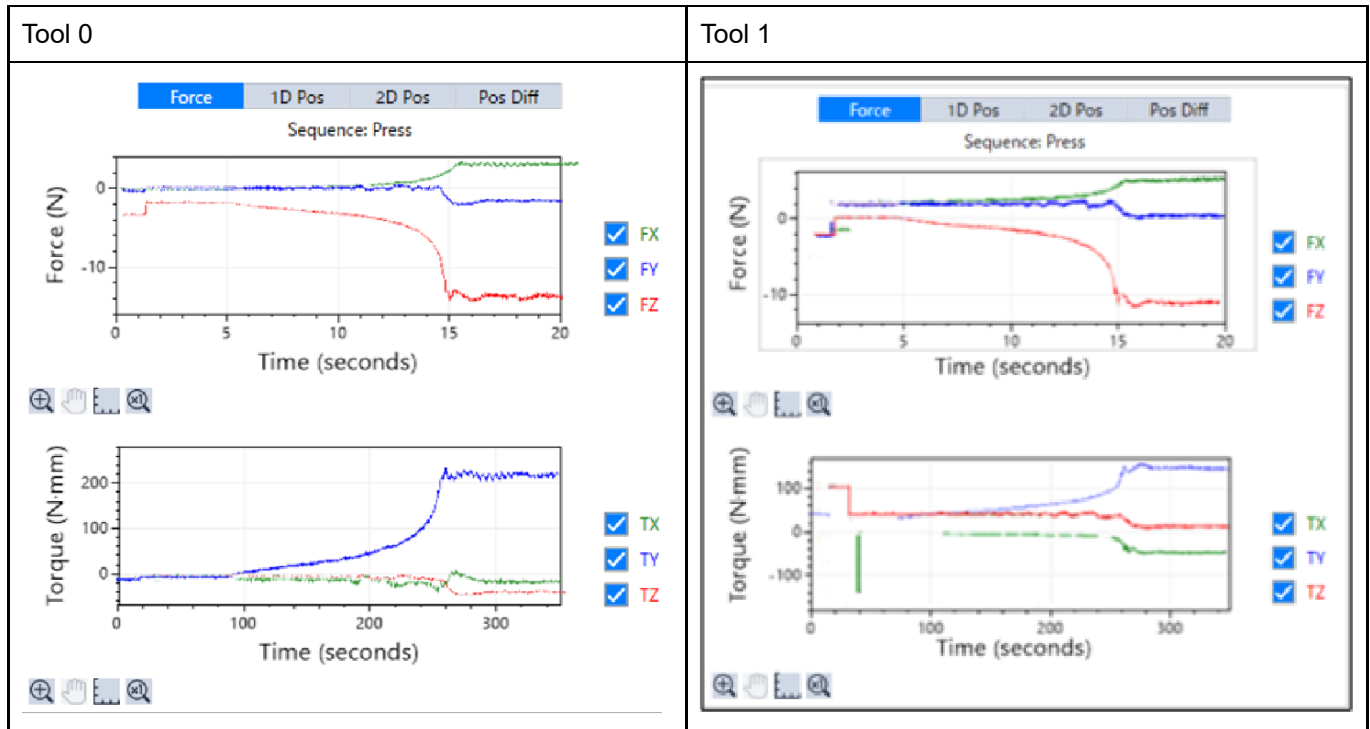

Now, tutorial for pressing to vertical-downward has completed.

4.6.2.2 Force Guidance Function (USB Connector Insertion)

The following describes how to insert a USB connector.

Commercially available USB cable and USB hub can be used for workpiece.

Please prepare a gripper for fixing or grasping the workpiece by yourself. If the setting is not correct, the workpiece will get damages. Make sure to prepare the USB device which is okay to get damages. Also, proceed this tutorial with a workpiece in non-energized state.

Make sure to set the position of workpiece or inserting direction as same as the picture below. To grasp the USB connector, in this tutorial, you can use "screws" to fix the USB connector.

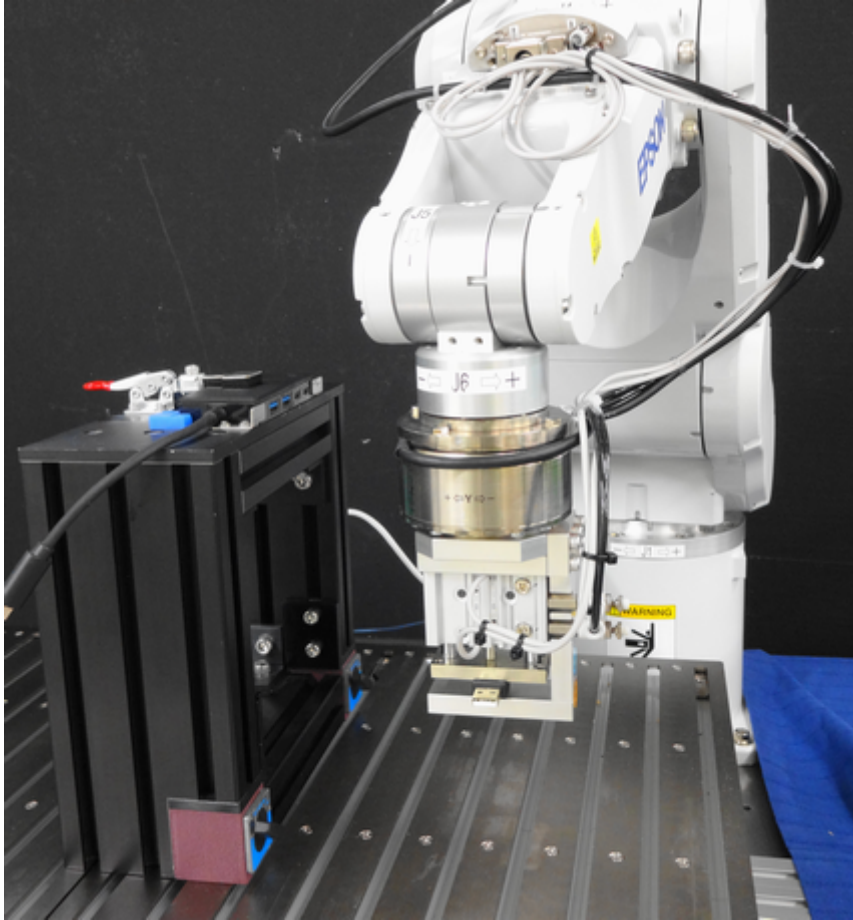

⚠ CAUTION

The parameters described in the example on the following pages are reference values.

This tutorial uses relatively stable parameters, but depending on the operating environment, the operation may not be successful or the motion may be vibratory. Note that adjusting the parameters may be required. note that

Slow, stable parameters are used for convenience of explanation. For high-speed operation, adjusting the parameters is required.

4.6.2.2.1 Sequence wizard

The following describes how to create a force guide sequence for "USB connector insertion".

1. Enter "USBInsertion" in the [Enter name for new sequence] box. Click the [Next] button.

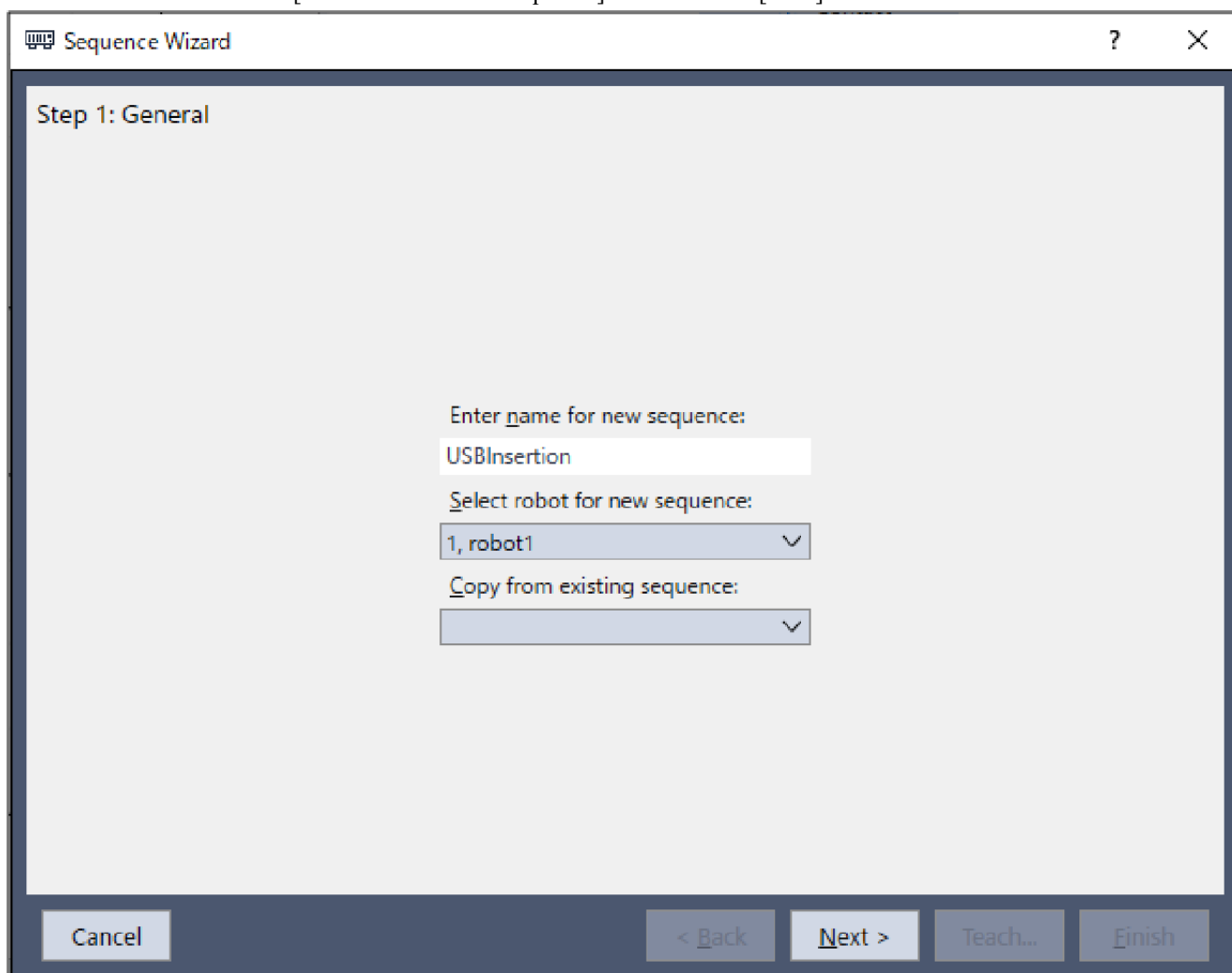

2. The [Step 2: Select sequence type] dialog box is displayed. Select [Template]. Click the [Next] button.

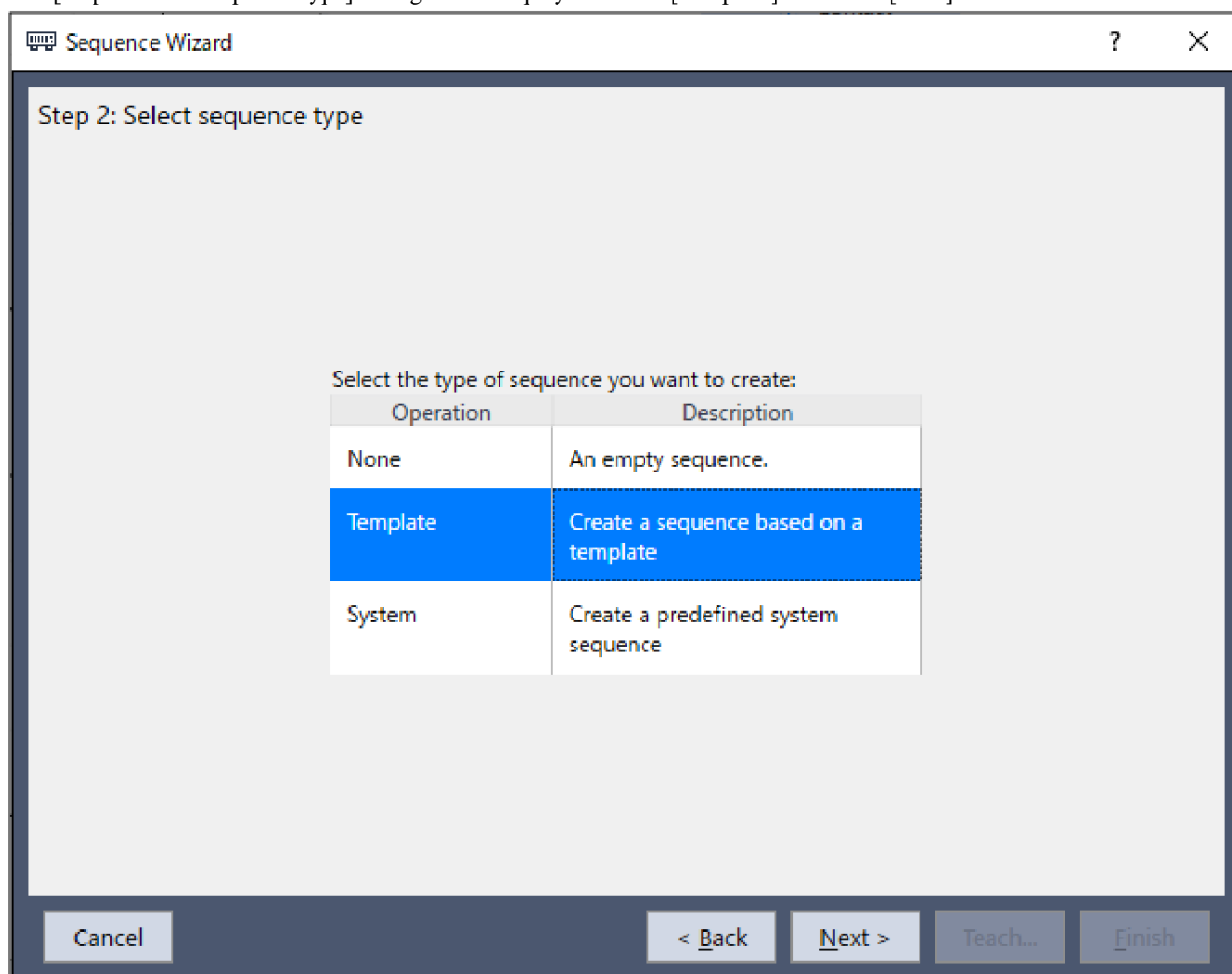

3. The [Step 3: Select type of force guidance operation you want to do] dialog box is displayed. Select [Connector Insertion]. Click the [Next] button.

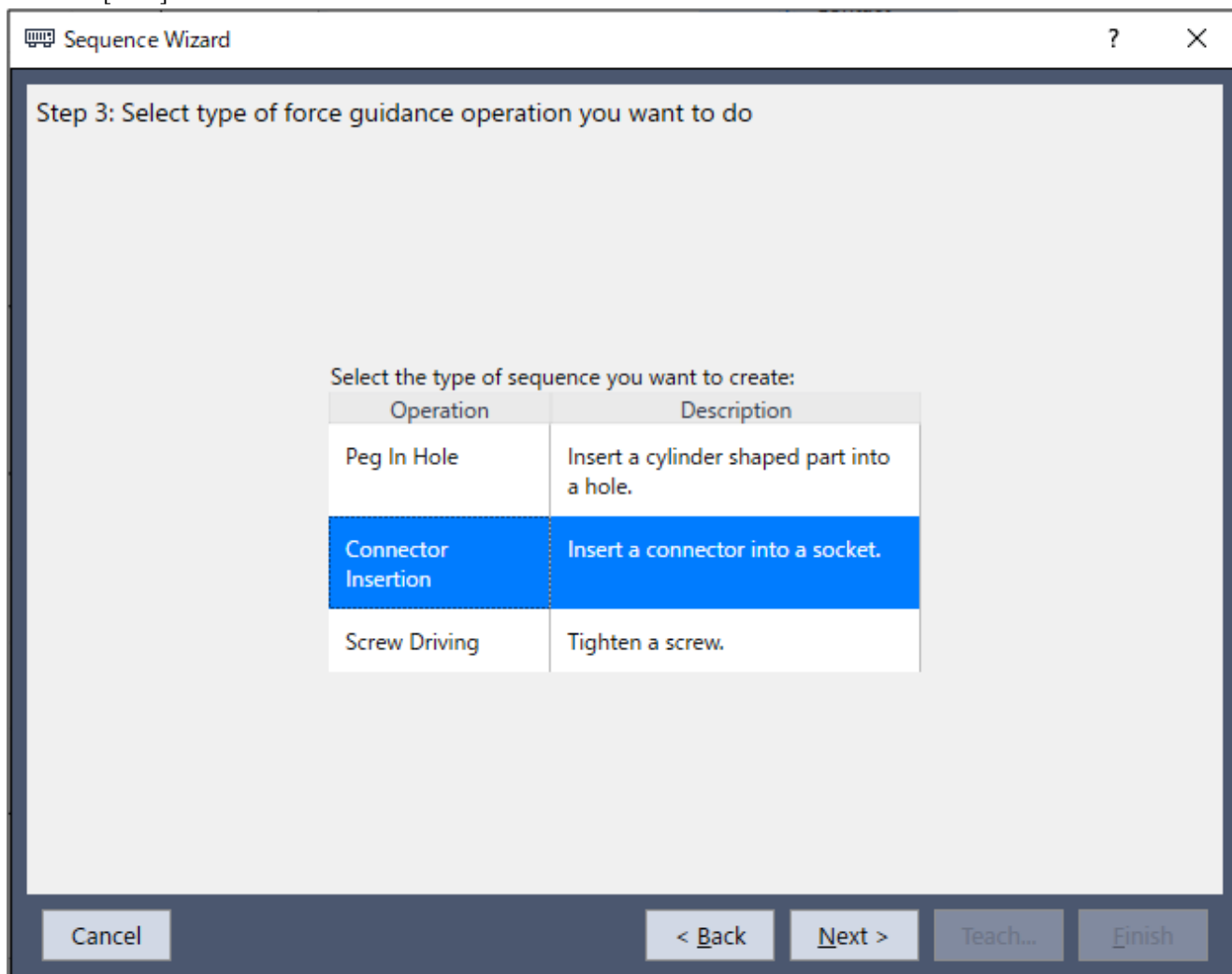

- The [Step 4: Select the sequence template for the selected operation] dialog box is displayed.
Select [With Probe].
Click the [Finish] button.

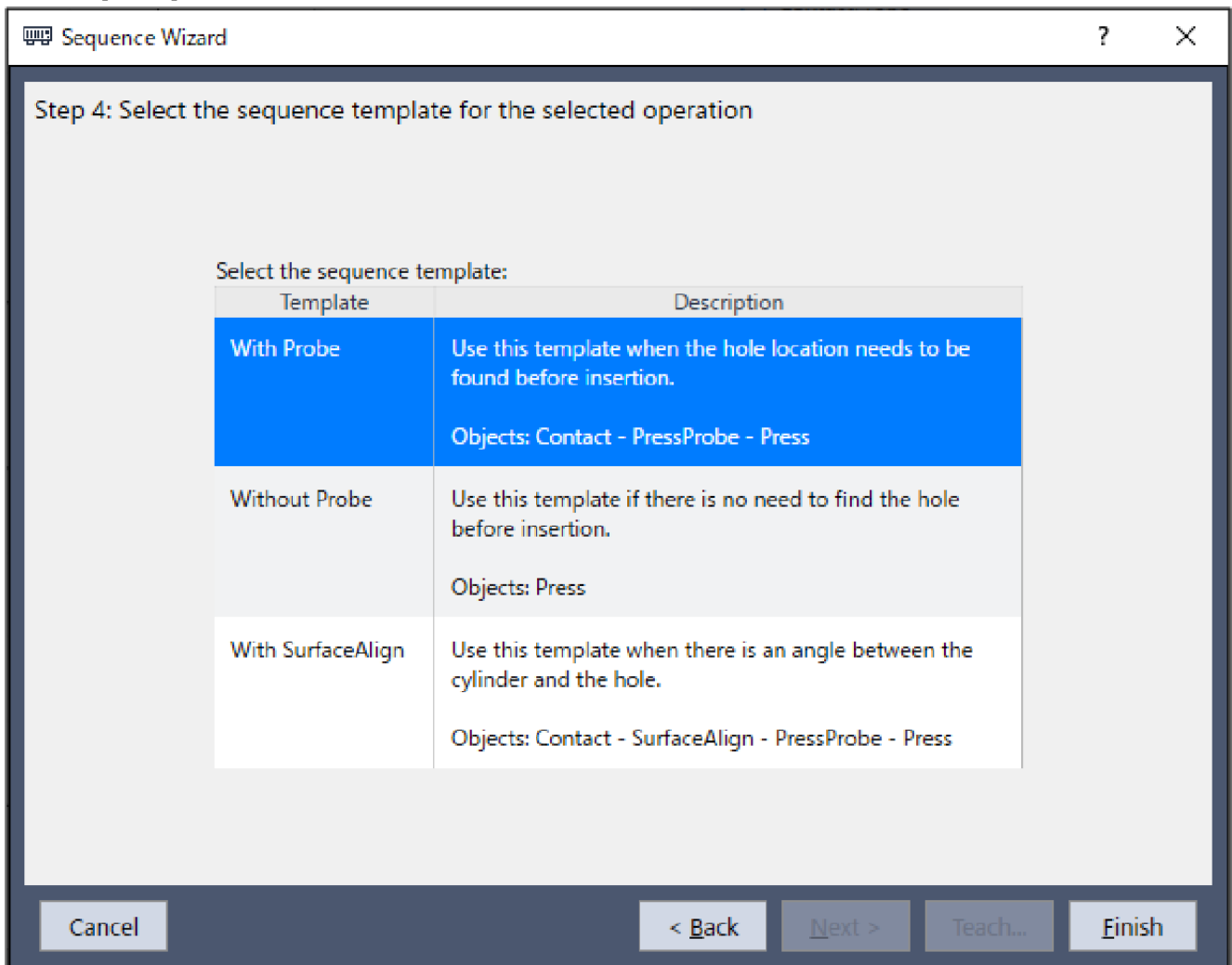

5. Confirm that the [USBInsertion] sequence is created.

ContactProbe - Press

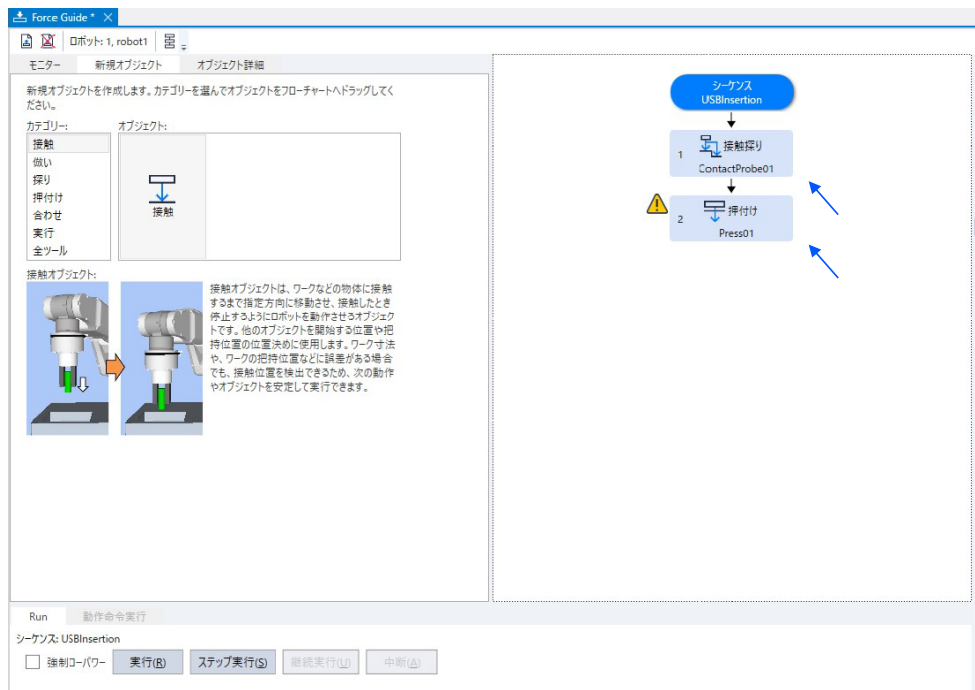

4.6.2.2.2 Confirmation of Tool Setting

When inserting the connector, you need to pay attention to the insertion direction of the actual connector and the setting of the current tool. The following describes how to confirm the setting by using simulator functions.

1. Click Epson RC+ menu-[Tools]-[Simulator]. The [Simulator] window is displayed.

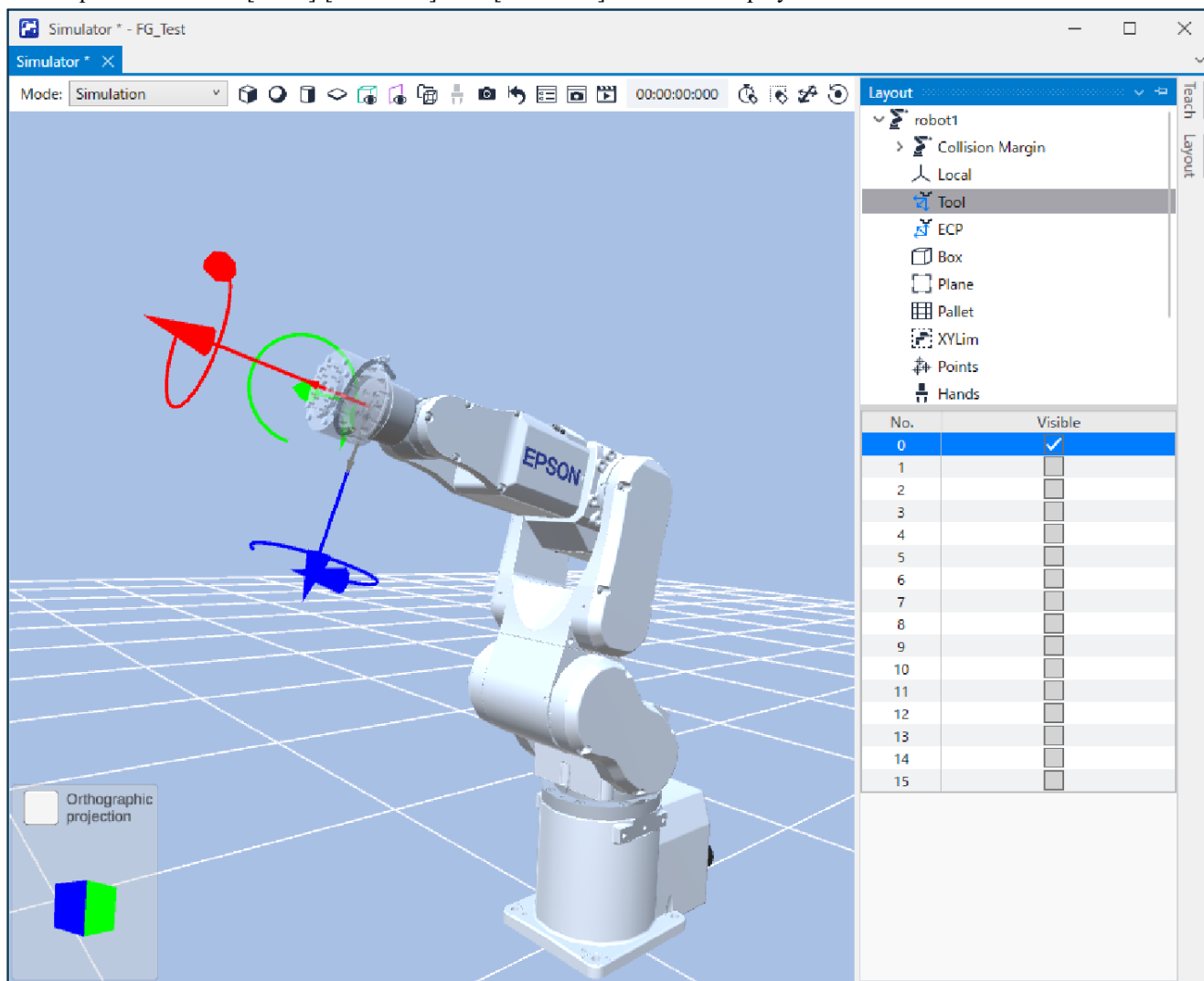

2. Click the object tree-[Manipulator Name]-[Tool].

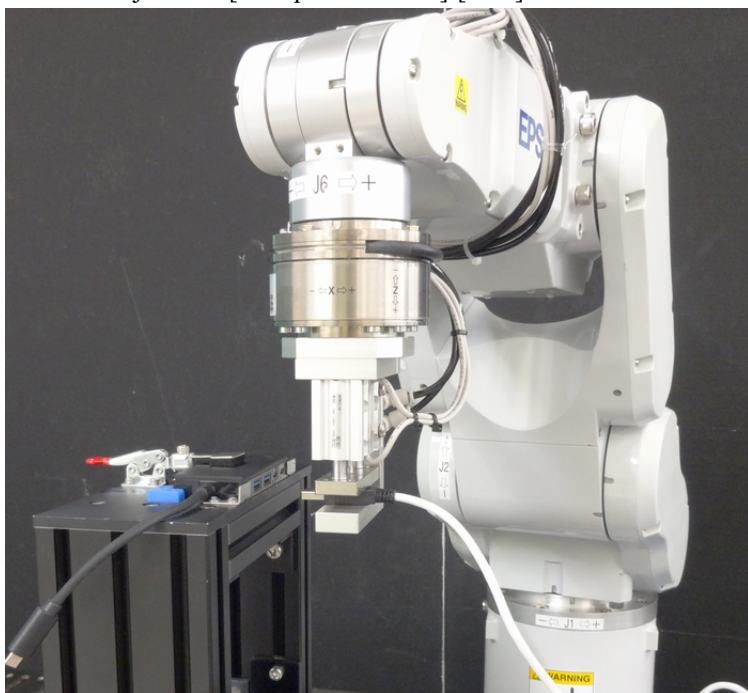

3. Place a checkmark in "No.0"-[Visible] check box. "Tool 0" is selected. Compared with the actual robot, you can see that the robot insets to "-X" direction of the tool in this tutorial.

To detect the force of rotational direction correctly, perform the tool setting to position to grasp or contact.
In this tutorial, only the force control function in the translational direction is used. Therefore, if you omit the setting, motion will be the same.

In this tutorial, proceed with "Tool 0".

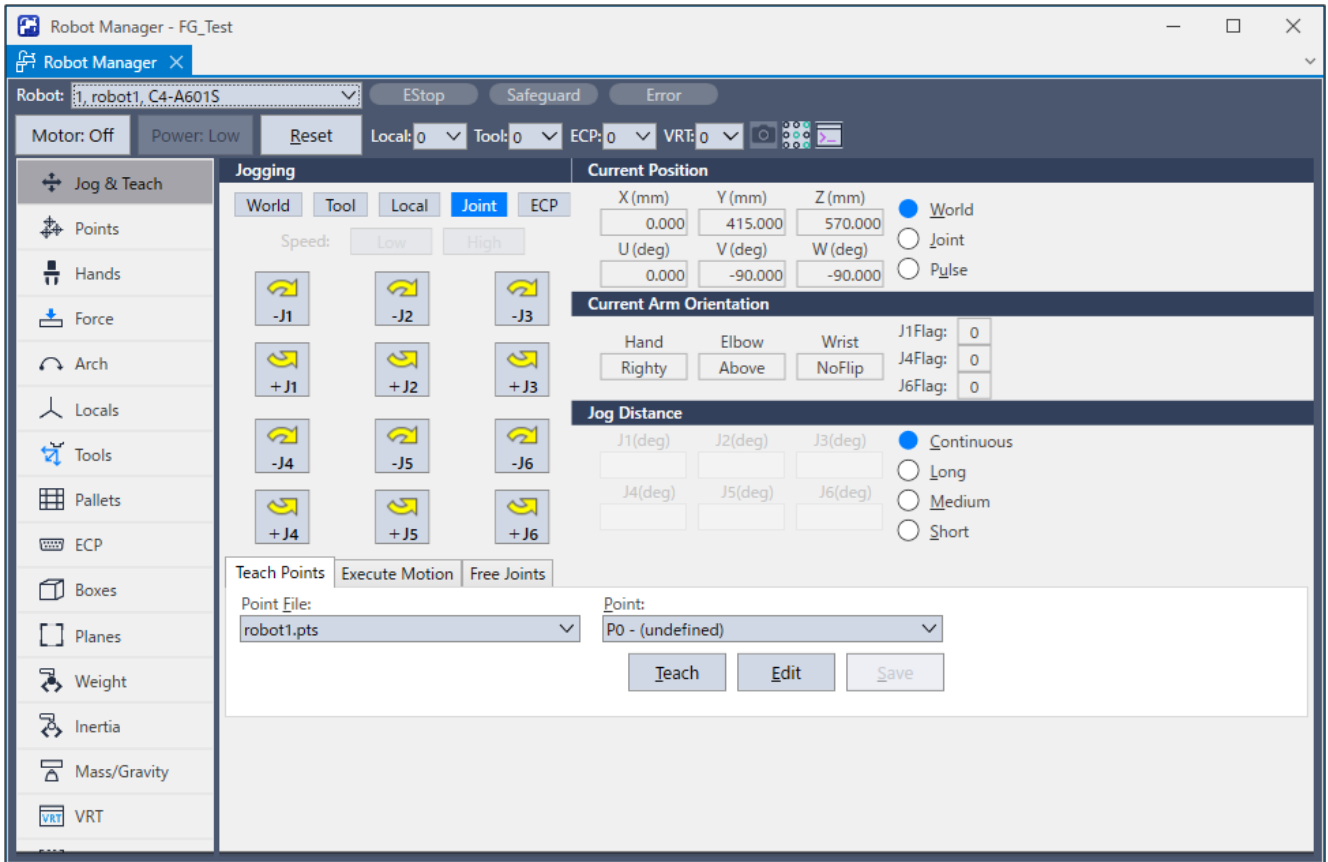

4.6.2.2.3 Position Teaching

The following describes how to teach start position of the connector insertion motion.

1. Click Epson RC+ menu-[Tools]-[Robot Manager]. The [Robot Manager] dialog box appears.

2. Select the [Jog & Teach] tab.

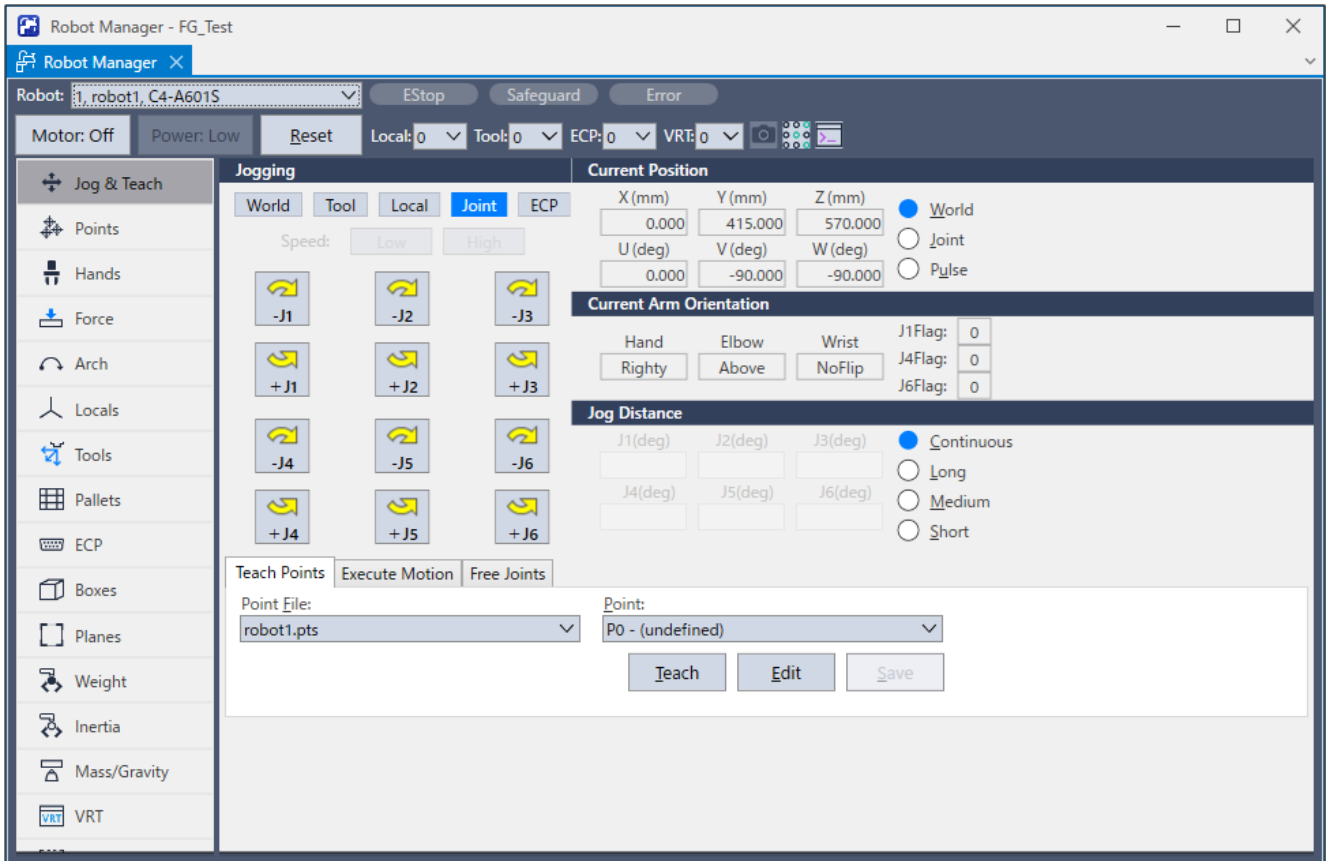

3. Select Epson RC+ menu-[Tools]-[Force Monitor]. The [Force Monitor] dialog box is displayed.

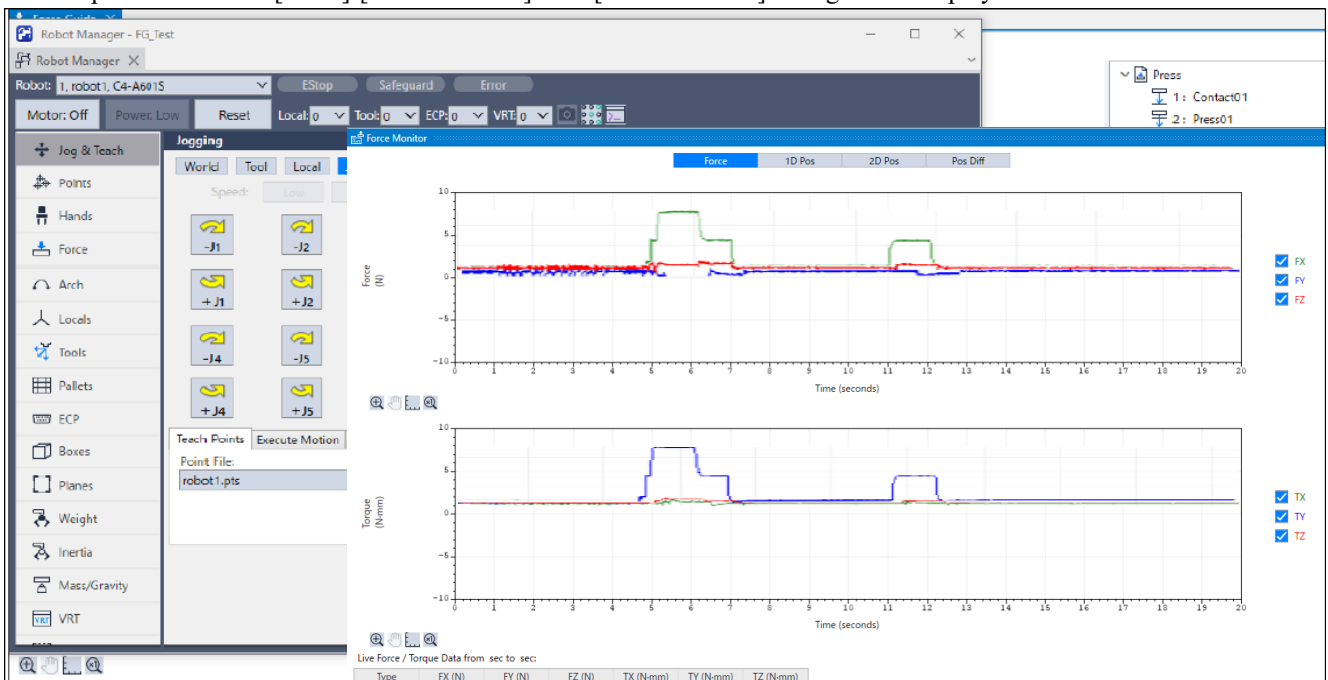

4. Select the [Start Live] button. Start displaying the output value from the current Force Sensor.
5. Click the Jog button and move the robot to a position where the two USB connectors will face each other and be parallel.
6. Click the [Reset Sensor] button. Since the effect of gravity and drift of sensor value are eliminated, the current value will be "zero" position.
7. Select [Jog & Teach]-[Jog Distance] and click the [Short] button. Move the robot to translational direction. Move the robot while clicking the Jog button several times until the USB connector contacts with the USB port.

When the connector contacts with the port, output value of the Force Sensor changes. Check the change of monitor value according to the timing of jog motion.



8. Select "P5" in the [Point] dropdown.
9. Click the [Teach] button.
10. The [New Point Information] dialog box is displayed. Enter "USBContact" on [Point Label] and click the [OK] button.

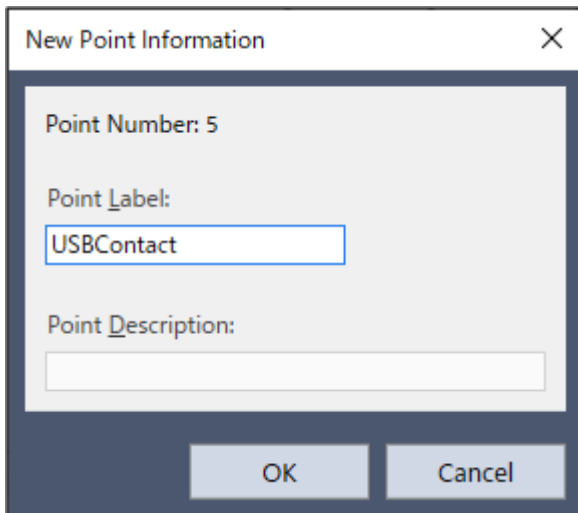

11. Select [Medium] on [Jog Distance]. Move the robot 3mm (click the Jog button three times) in a direction where the USB connector does not make contact with the USB port. Also, visually move the robot in the +Y direction by approximately 1 mm from the center of the connector. Set this position as a start point of inserting the connector.

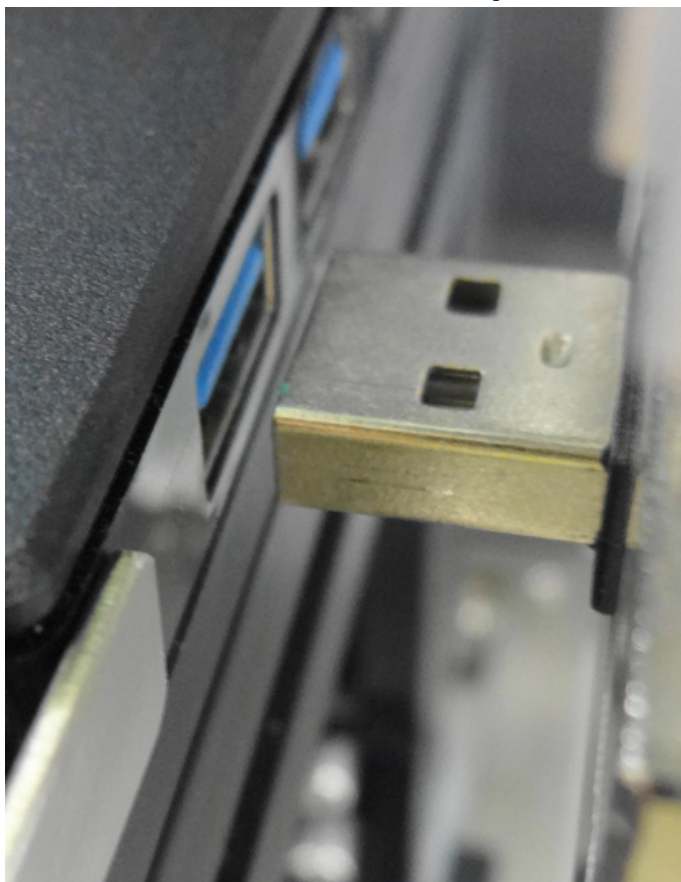

12. Select "P4" in the [Point] dropdown.
13. The [New Point Information] dialog box is displayed. Enter "USBStart" on [Point Label] and click the [OK] button.
14. Click Epson RC+ menu-[File]-[Save All]. The file is saved.

4.6.2.2.4 Property Setting

The following describes how to set properties that are necessary to insert connector.
Specifications of USB TypeA connector are as follows:

Insertion force: 35N or less

1. The  mark is displayed on the flow chart by default. You need to set properties.

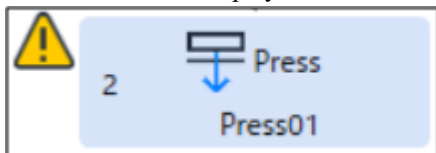

Move the mouse pointer onto the  mark to display the tool tips. The tool tips show settings or content which need to be modified.

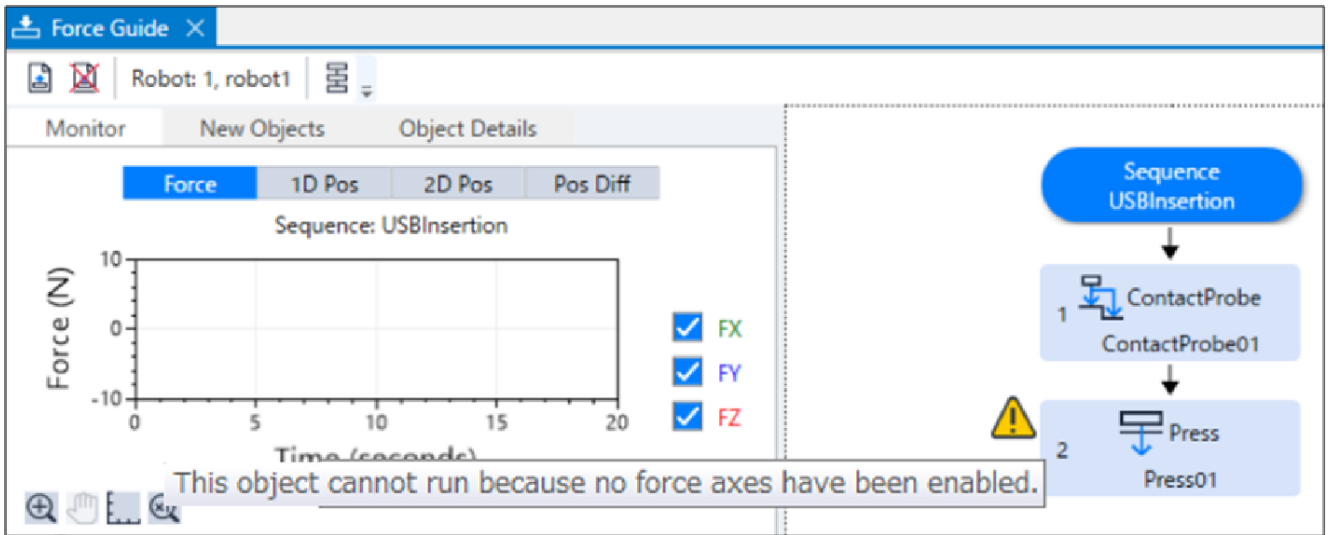

Set in order from the Step 1.

2. Select the [ContactProbe01] object. Properties and Results are displayed.

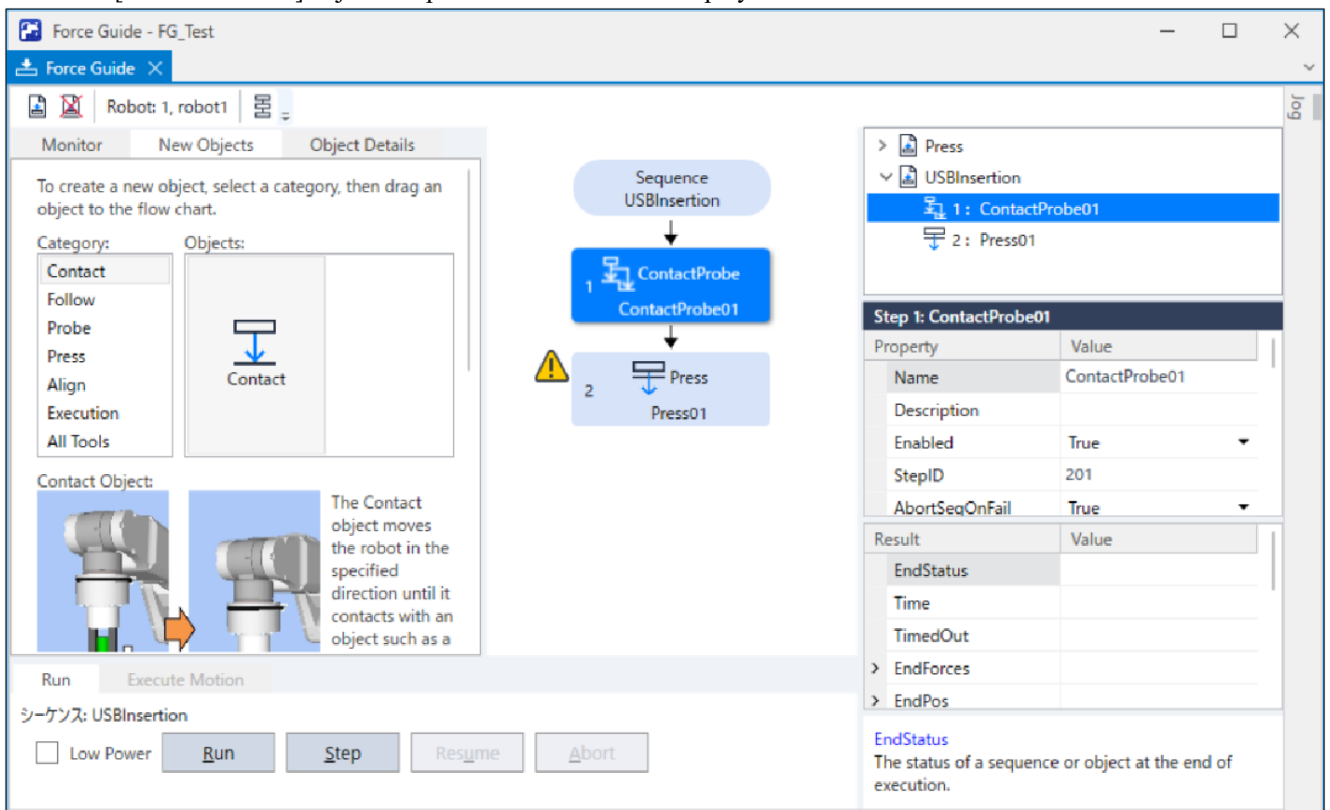

3. Set the value of the [Contact]-[Orient] property to "-Fx".

4. Set other properties as follows.

For more details, refer to the following section.

Software **ContactProbe Object**

Item	Value	Description
ProbeTrajectory	Straight	Set a straight line probe motion. The robot approaches to the plane at a regular interval (set by [Interval]).
AccelS	200	Set the translational acceleration of the movement.
SpeedS	50	Set the translational velocity of the movement. Velocity for depart motion or translation.

Item	Value	Description
Destination	DestRelativeX	0 Set a relative movement amount to each direction from the start point to the destination point. The robot does not shift to X direction.
	DestRelativeY	-3 The robot moves up to 3mm in the -Y direction and probes.
	DestRelativeZ	0 The robot does not shift to Z direction.
Contact	ContactInterval	0.5 Set an interval of the contact motions. Set to 0.5mm.
	Orient	-Fx Set a direction to contact. The robot moves to the specified direction.
	Dist	3 Set a distance from the start point to the target contact point.
	DistMargin	0.5 Set a margin distance from the start point to the target contact point. Set to 0.5mm for one side.
	FirmnessF	2 Set a firmness of the force control functions. ContactProbe object affects to the contact speed. Reference value of the contact speed can be calculated by the following: [ContactForceThresh] / [ContactFirmnessF]
ForceEnd Conditions	Contact ForceThresh	3 Set a threshold to determine a contact. Set 3[N]. When a force of 3N or more is detected outside the expected contact range set by [ContactDist], the robot determines that the probe motion has failed, shifts 0.5mm in the -Y direction, and approaches again in a similar manner.
PosEnd Conditions	PosCheckType	Relative Plane Select the types of the end conditions related to positions . Set a Plane with a condition that the robot moves a relative amount from the start position. It is automatically generated by [ContactDist] +[ContactDistMargin].
	PlaneNumber	1 Set Plane number which is used for an end condition of positions. Overwrite Plane 1.
	PlaneEndCond	Inside Being inside of the Plane is an end condition. When the robot moved to the specified state, determined as the end condition is satisfied.
Timeout	30	Set a time-out period of a contact motion. Maximum time-out period is 30 seconds.

5. Click Epson RC+ menu-[File]-[Save File]. Settings are saved.

6. Set the properties of the [Press01] object as follows:

	Item	Value	Description
Fx	ControlMode	Press-	Mode of force control function. Press : The robot moves along the axis in the negative direction and presses.
	PressForce	20	Applied force when inserting. Set to 20N.
	Firmness	2	Set a firmness of the force control functions in X direction.

	Item	Value	Description
Fy	ControlMode	Follow	Perform the follow motion by the force control functions.
	Firmness	2	Set a firmness of the force control functions in Y direction.
Fz	ControlMode	Follow	Perform the follow motion by the force control functions.
	Firmness	2	Set a firmness of the force control functions in Z direction.
ForceEnd Conditions	ForceCheckEnabled	True	Enable the end conditions related to force.
	ForceCheckMode	Press	Press: Only the pressing is a target of determination.
	ForceCheckPolarity	Inside	Polar of the end conditions related to force. Being inside of the specified range is an end condition.
	PressCheckToIF	10	Range of the pressing direction of the end conditions related to force. Set a range of the end conditions. X axis: the force value remains inside the 20 ± 10 N range
	FollowCheckToIF	1	Y, Z axes: the force value remains inside the 0 ± 1 N range
	HoldTimeThresh	0.1	Set the duration time which is used to determine whether the end conditions have satisfied. Set 0.1 seconds.
Timeout		2	If the end condition has not satisfied for more than 2 seconds (e.g. no workpiece is existed), ends as a failure.

7. Click Epson RC+ menu-[File]-[Save File]. Modified properties are saved to the project.

4.6.2.2.5 Setting Confirmation

The following describes how to confirm the following setting by using a simulator.

- Pressing direction when inserting
 - Approach detection plane (Plane) for determination to start insertion
1. Click Epson RC+ menu-[Tools]-[Simulator].
The [Simulator] window is displayed.
 2. Click the object tree-[Tool]. Place a checkmark in the "No.0"-[Visible] check box. An arrow for "Tool 0" is displayed.

3. Click the object tree-[Force Sensor].

Set the [Transparent] property to "True". The arrow origin of the "Tool 0" is displayed.

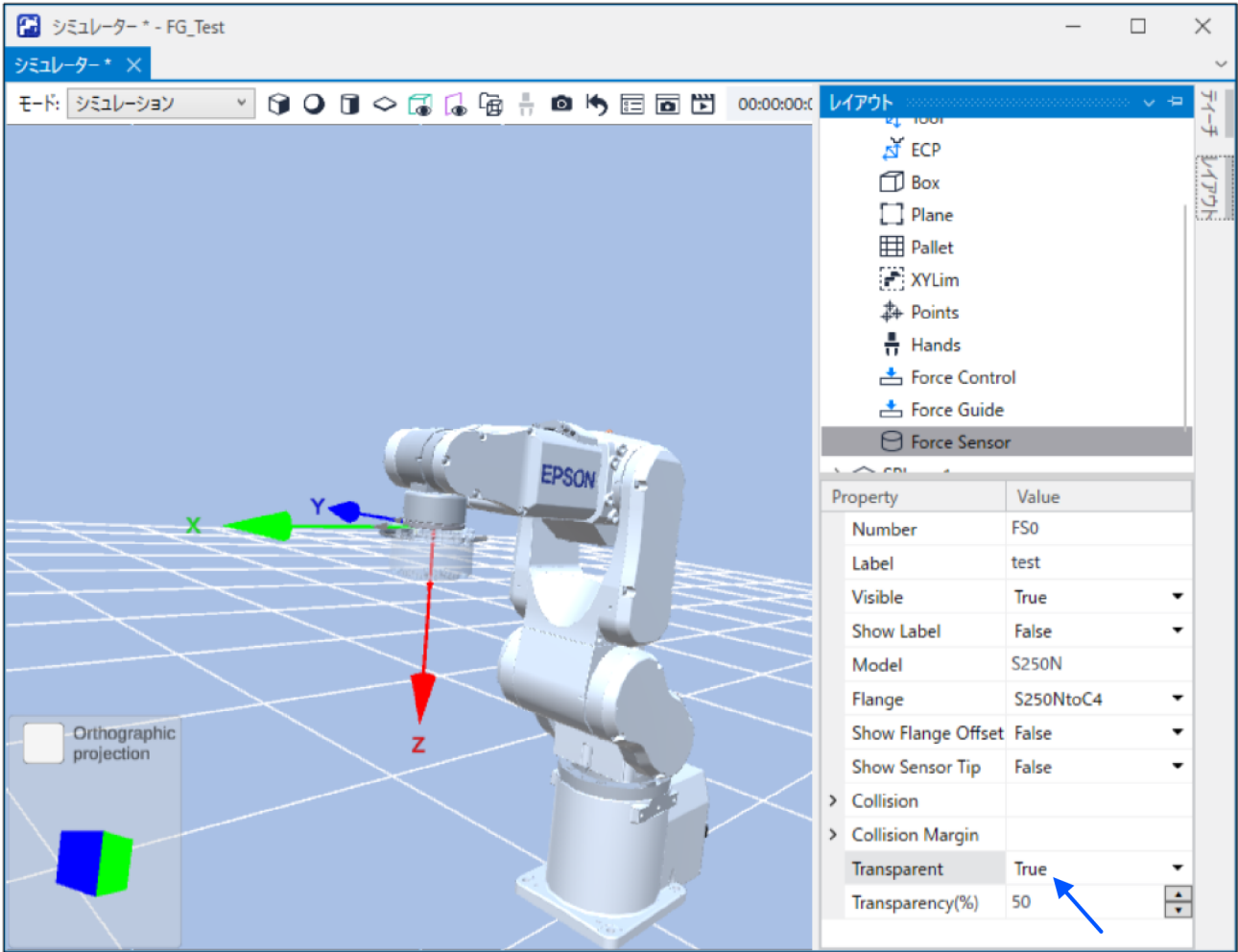

4. Select the object tree -[Force]-[Force Guide]-[USBInsertion].

Place a checkmarks on "ContactProbe01" and "Press01"-[Visible] checkboxes.

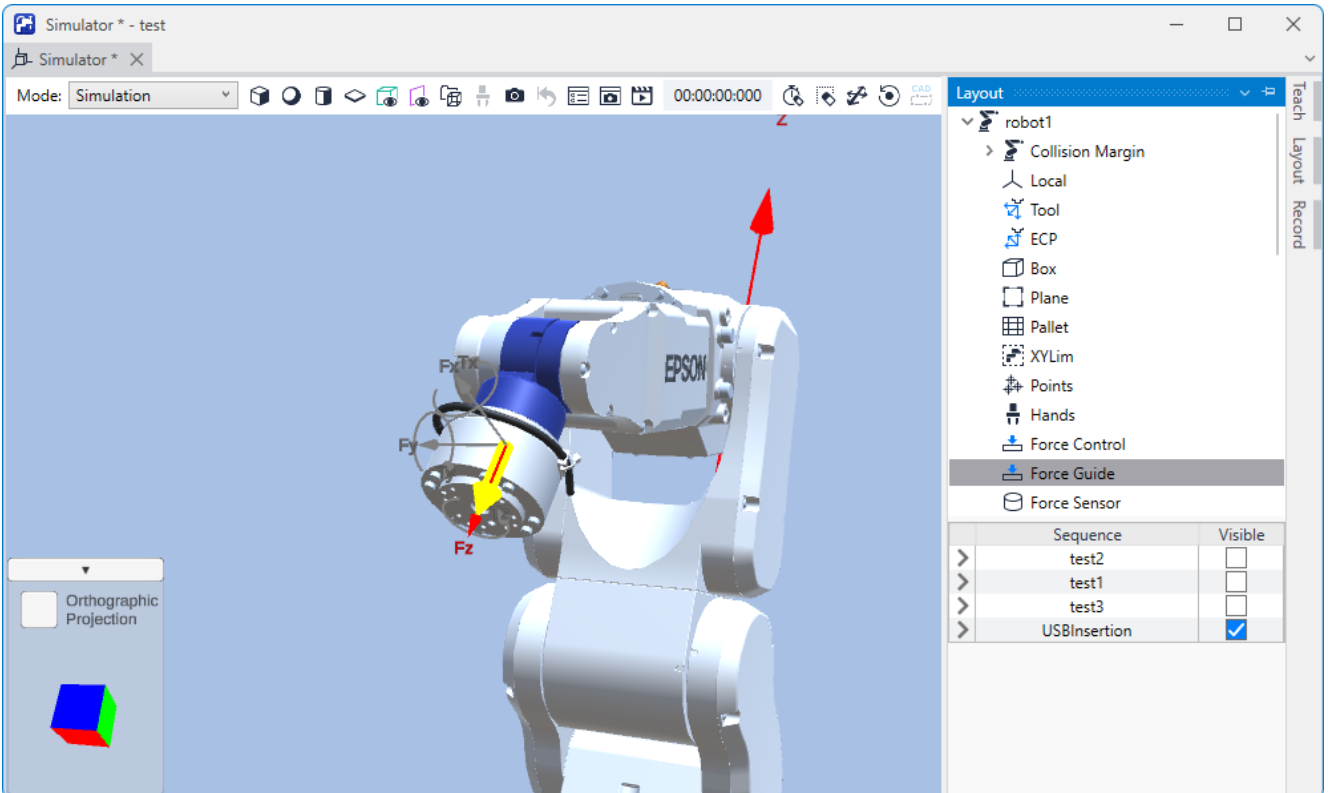

- 5. Check the Plane setting. To see the image more clearly by hiding the yellow arrow, remove the checkmark from the [Visible] checkbox in the step (4).
- 6. Set the [Force Guide] window-[ContactProbe01] property-[Pos End Condition]-[PosCheckEnabled] to "True".

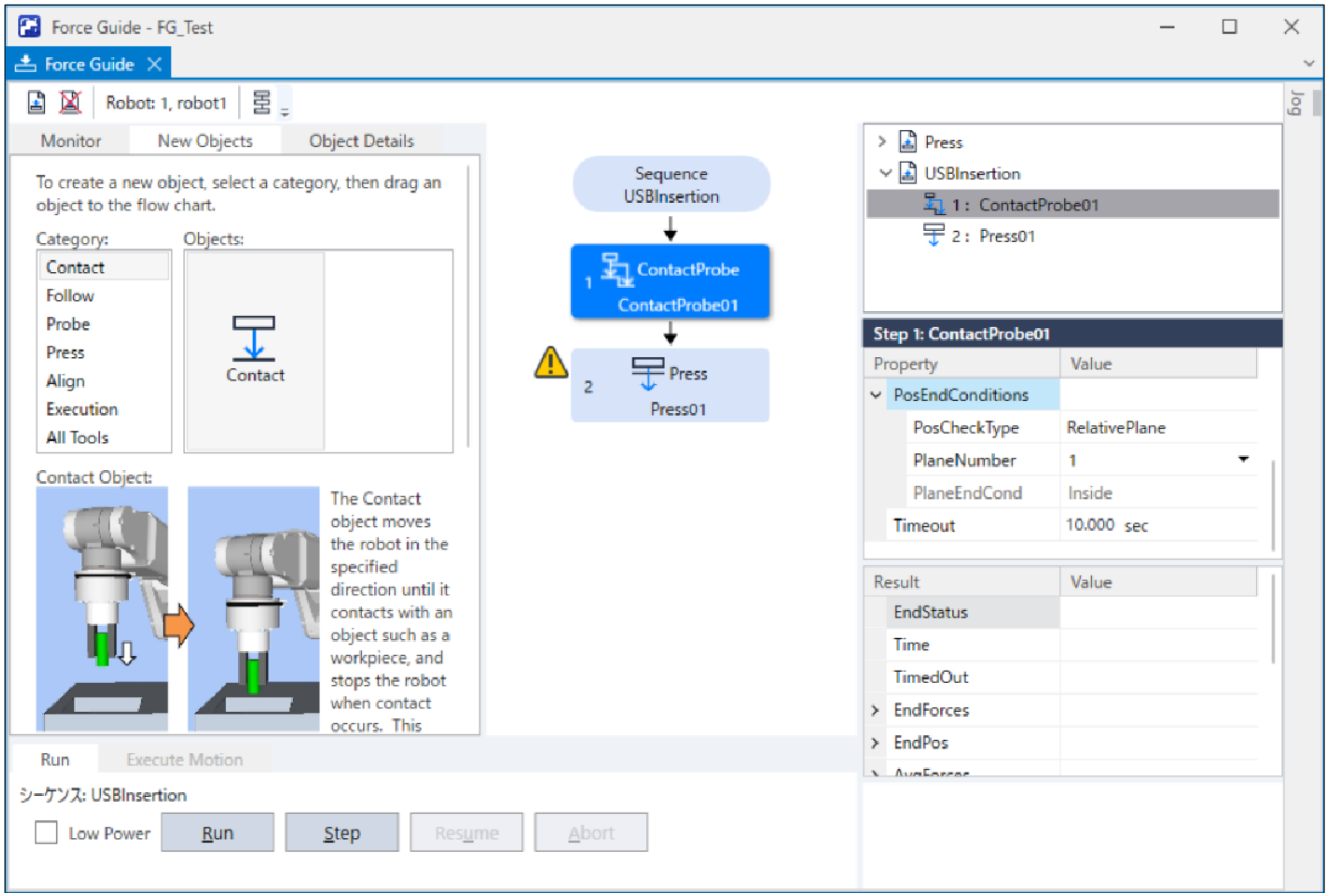

- 7. Click the [Force Guide] window-[ContactProbe01] property-[Pos End Condition]-[PosCheckType], and click the icon on the right side of "RelativePlane" which is the value of [PosCheckType].
- 8. The following dialog box is displayed.
Check that the [PosCheckType:] is "RelativePlane".
Click the [Create] button.

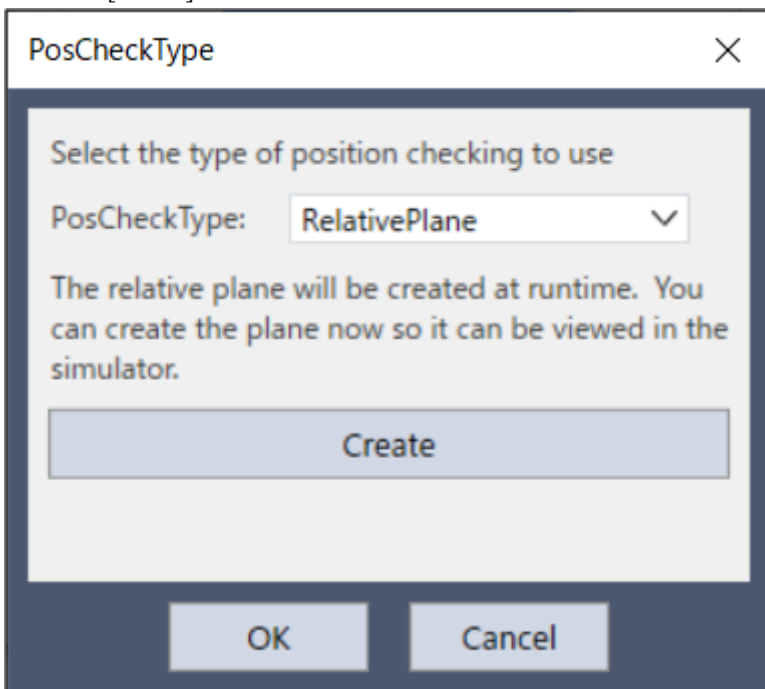

9. The following message is displayed. Click the [OK] button.

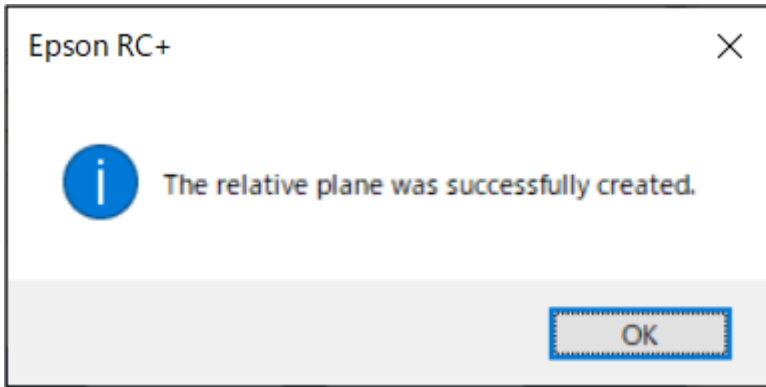

10. Click the [OK] button on the [PosCheckType] dialog box.

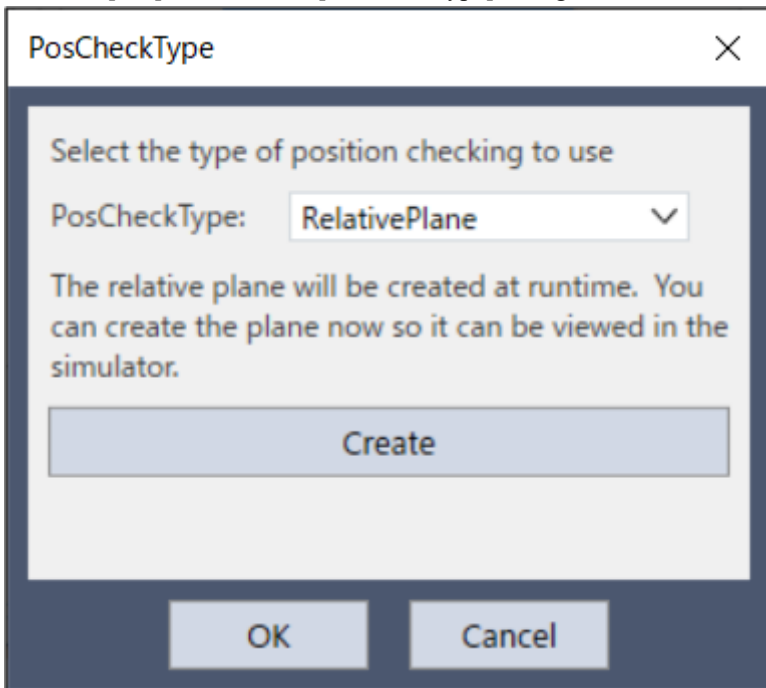

11. Display the [Simulator] window.

Select the object tree-[Plane].

Place checkmarks in the [Visible] and [Origin] checkboxes for "Number 1."

Plane 1 is approach detection place of ContactProbe. If a tool exists inside the range of red arrow (Z direction) which displays an origin, return value of Plane is set to True. If it is not inside the range, the return value is set to False.

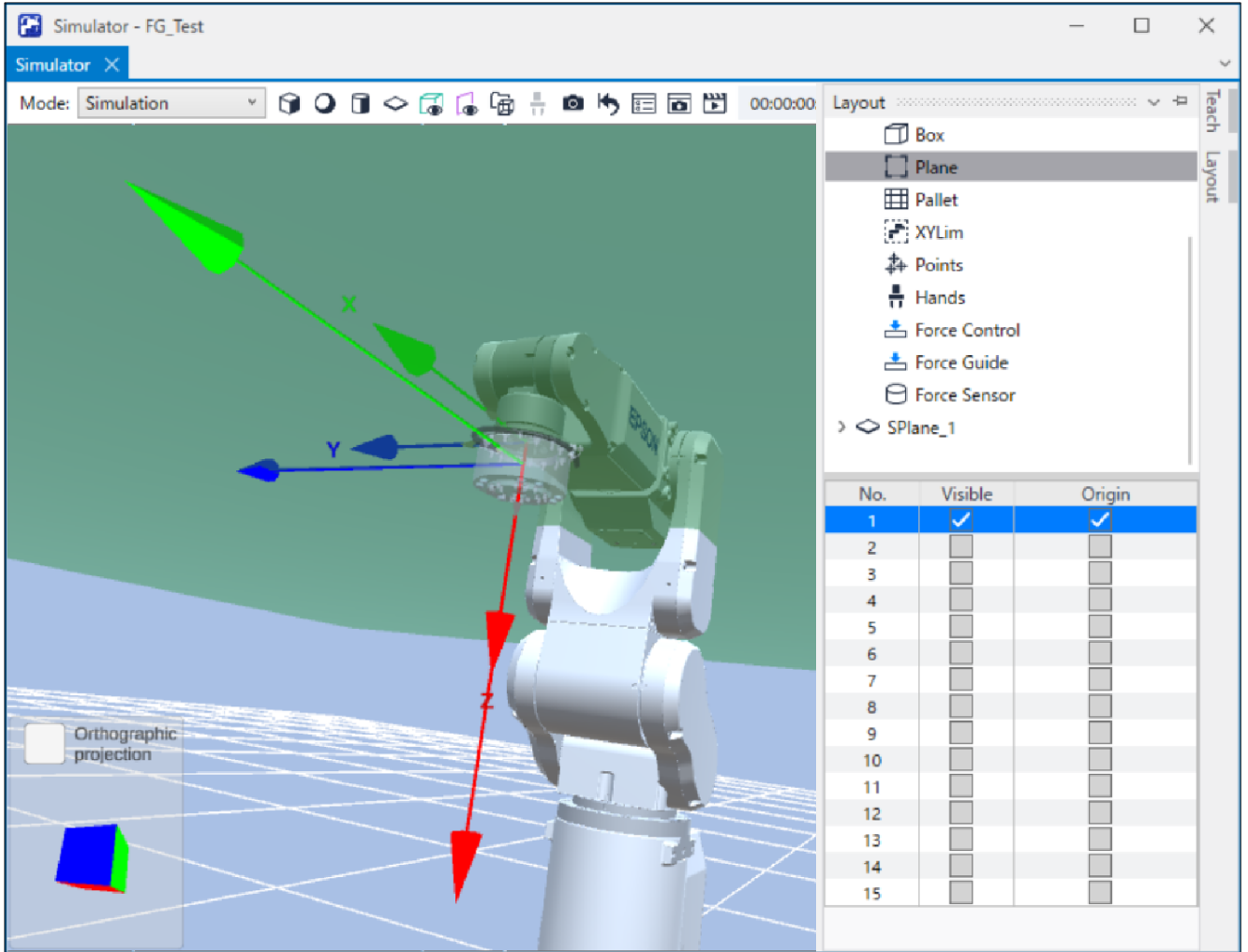

[Reference] Positional relationship with Plane

The positional relationship of the robot's current position and Plane is as shown below. If the robot's current position is in the +Z direction area from the Plane origin, it will be "Inside".

	Outside	Inside
Positional relationship with Plane 6-axis robot		
Determined value of Plane (GetRobotInsidePlane)	0 = Outside	1 = Inside

12. If Plane or Z-axis direction of Plane (end determination condition) is displayed in a different position from the insertion direction, refer to the following section and change the setting.
Software [Property Setting](#)

4.6.2.2.6 Motion by Force Guidance Function

The following describe how to execute a force guide sequence that inserts a USB connector by Epson RC+.

1. Open the [Force Guide] window.
2. Select the [Jog] tab.
3. Click the [POWER HIGH] button.
If the robot will break the workpiece, consider to operate in "Low Power Mode".
(However, the robot motions by the force control motion are different from that in high power mode since settings of speed and acceleration are restricted in low power mode. Therefore, the force which is larger than in the high power mode may be applied to the workpiece.)
4. Click the [Execute] button.
Program is compiled and transmitted to the Robot Controller.
If the setting is not correct, an error occurs. Check the settings so far and follow the error message to modify the parameters.
5. When the operation is correctly completed, the USB connector is fully inserted.

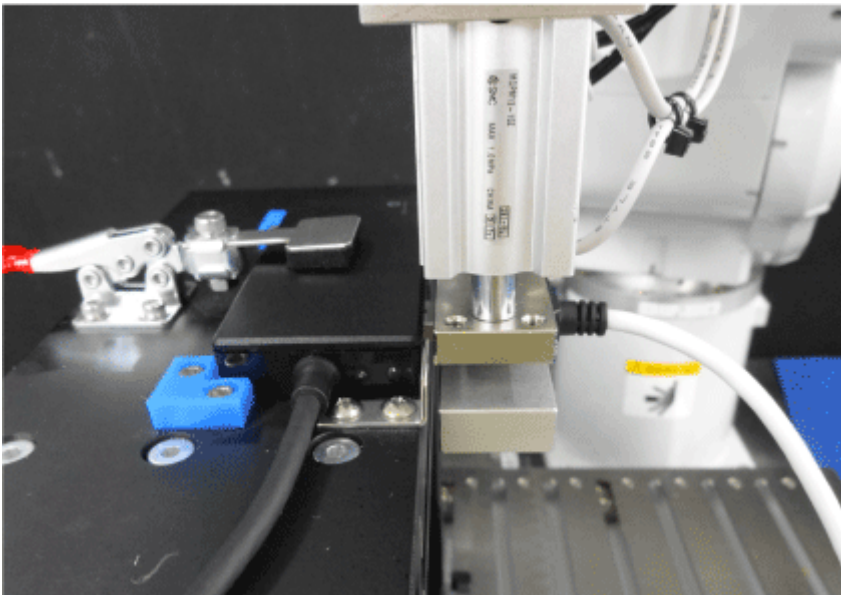

If the connector insertion is failed, you can analyze a cause.
For more details, refer to the following section.
Software [Motion Analysis by Monitor](#)

4.6.2.2.7 Return to the Non-Contact State

The following describes how to return to the non-contact state.

Force continues to be applied to between the robot and the USB device even the connector is connected.
To prevent the robot and the end effector from malfunction or damage, move the robot away from the object immediately after the operation ends, and make sure that no force is applied to the object. If it is obvious that no force is applied to the object, you can omit this step.

Steps to return to a non-contact state are as follows:

- Click Epson RC+ menu-[Tools]-[Robot Manager]-[Jog & Teach] panel-[Jog] group and perform jog motion manually to move the robot away from the object.
- Click Epson RC+ menu-[Tools]-[Robot Manager]-[Jog & Teach] panel-[Execute Motion] tab and move the robot away from the object.
- Execute Move command on [Command Window] and move the robot away from the object.
- Add SPELFunc object after Press object, and automatically move the robot away from the object at the end of the force guide sequence.

This section describes how to set the robot to the non-contact state by clicking [Robot Manager]-[Jog & Teach].

1. Display the [Robot Manager] dialog box.
2. Select the [Jog & Teach] panel. Set the Jog Distance to [Continuous] or less than "1mm". If you select [Long] and move the robot, the workpiece may get damaged if you click the wrong direction button. note that
3. Use the Jog button to move the robot in the +X direction (opposite to the insertion direction).

Now, it is the non-contact state.

4.6.2.2.8 Motion Analysis by Monitor

The following describes how to use Epson RC+ to check the operation results of a force guide sequence. The following windows are when the sequence motions are operated successfully.

1. Open the [Force Guide] window.
2. Click the sequence flow of [USBInsertion].
3. Select the [Monitor] tab. Select the [Force] tab.

Force and position during the [USBInsertion] sequence execution are displayed in the graph.

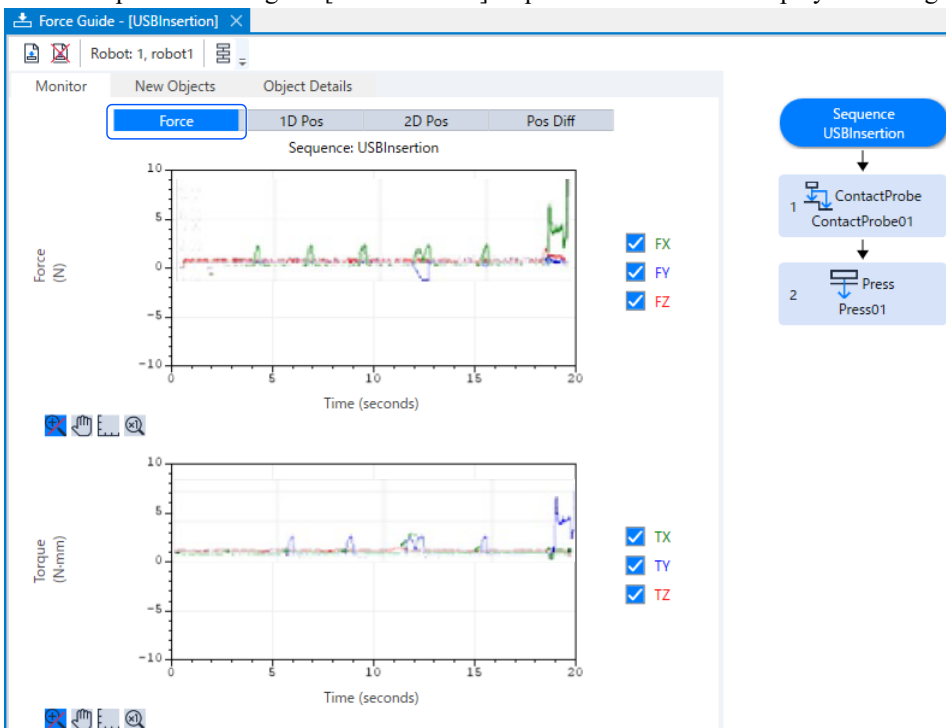

- Click the object flows of [Step1] and [Step1] to display the force and the position during the execution of the selected force guide object.

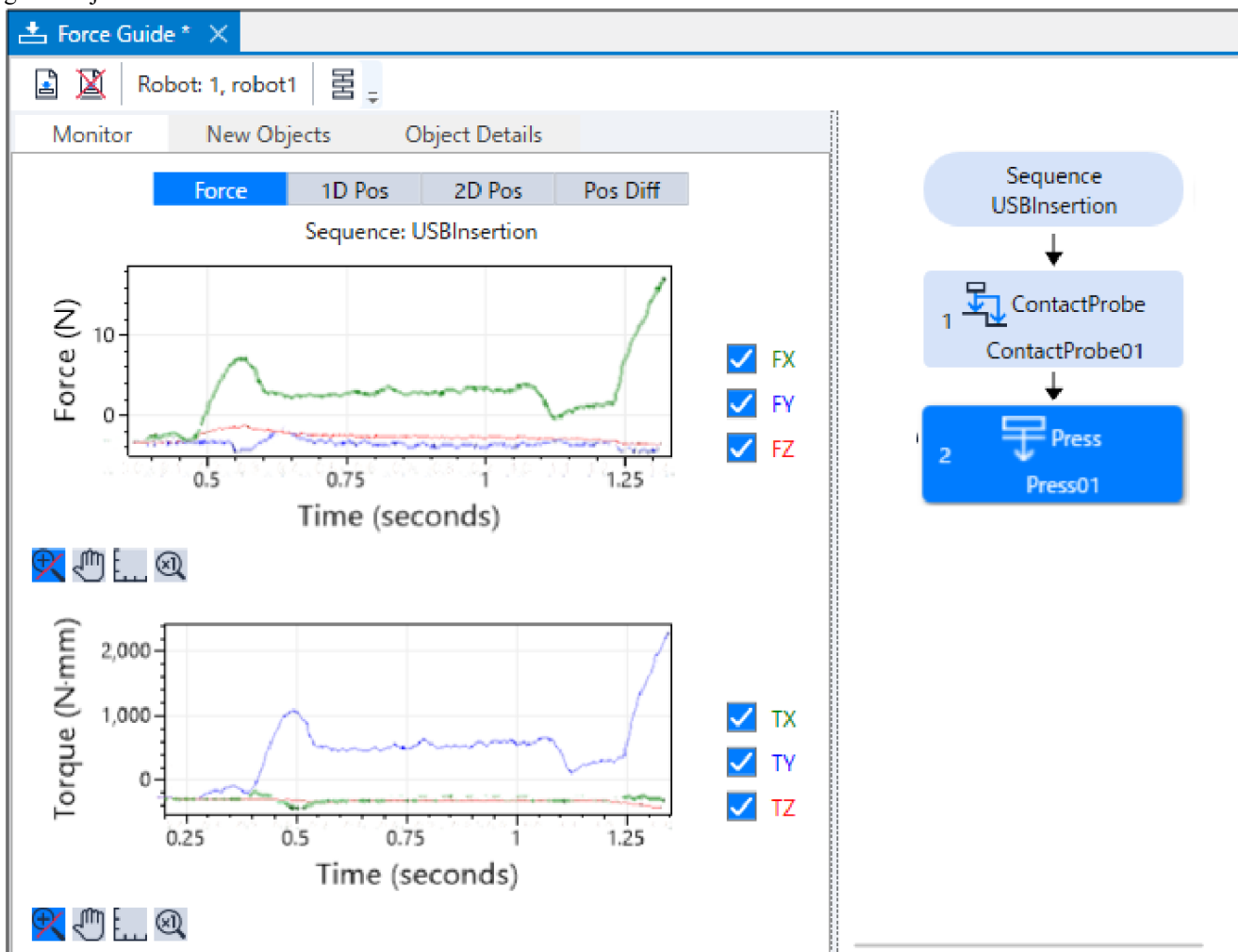

- Click the [USBInsertion] sequence.
Select the [Monitor] tab. Select the [1D Pos] tab.
Graph for analysis is displayed. (horizontal axis: Time, vertical axis: Position)

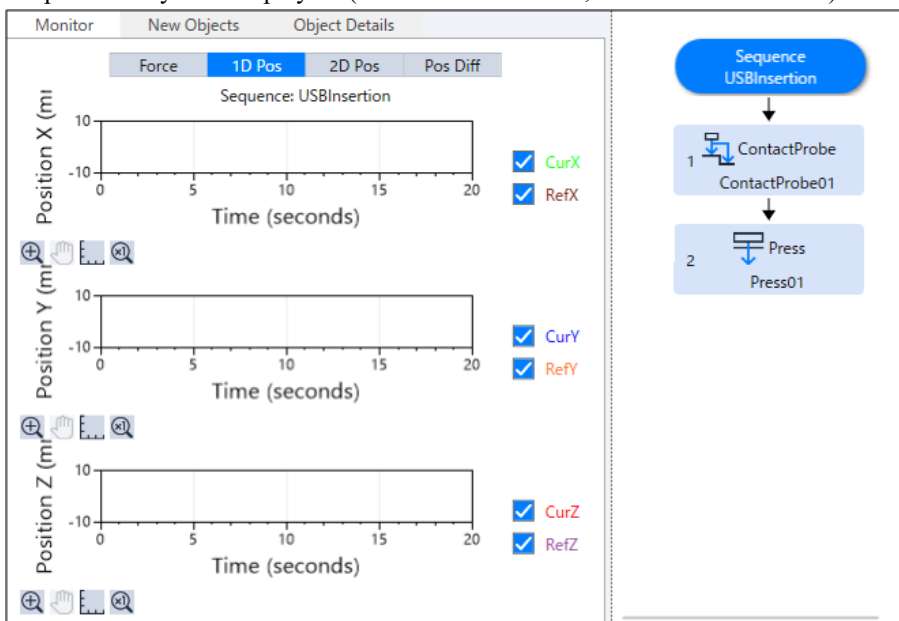

6. Select the [2D Pos] tab.

Graph for analysis is displayed. (horizontal axis, vertical axis: Position)

It helps to imagine the follow trajectory on the Y and Z planes.

- Red line: Cross-sectional trajectory of probe motion
- Blue line: Insertion trajectory in the +X direction by the force control function

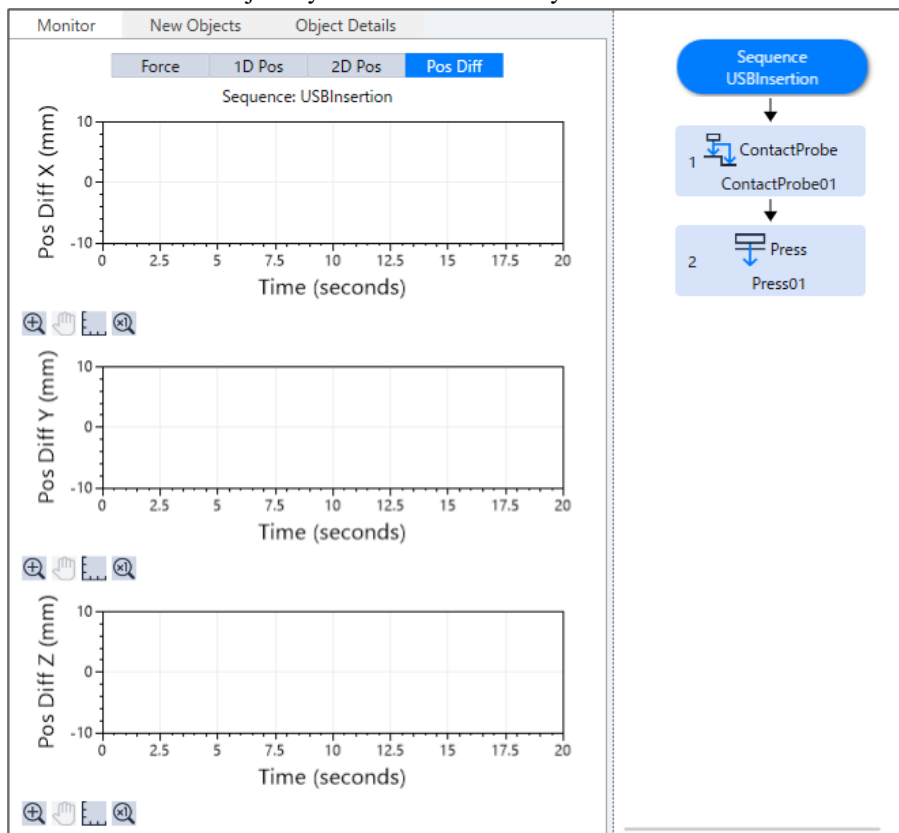

7. Select the [Pos Diff] tab.

Record shifts by force control as relative position changes. It is different from the graph on the [1D Pos] tab.

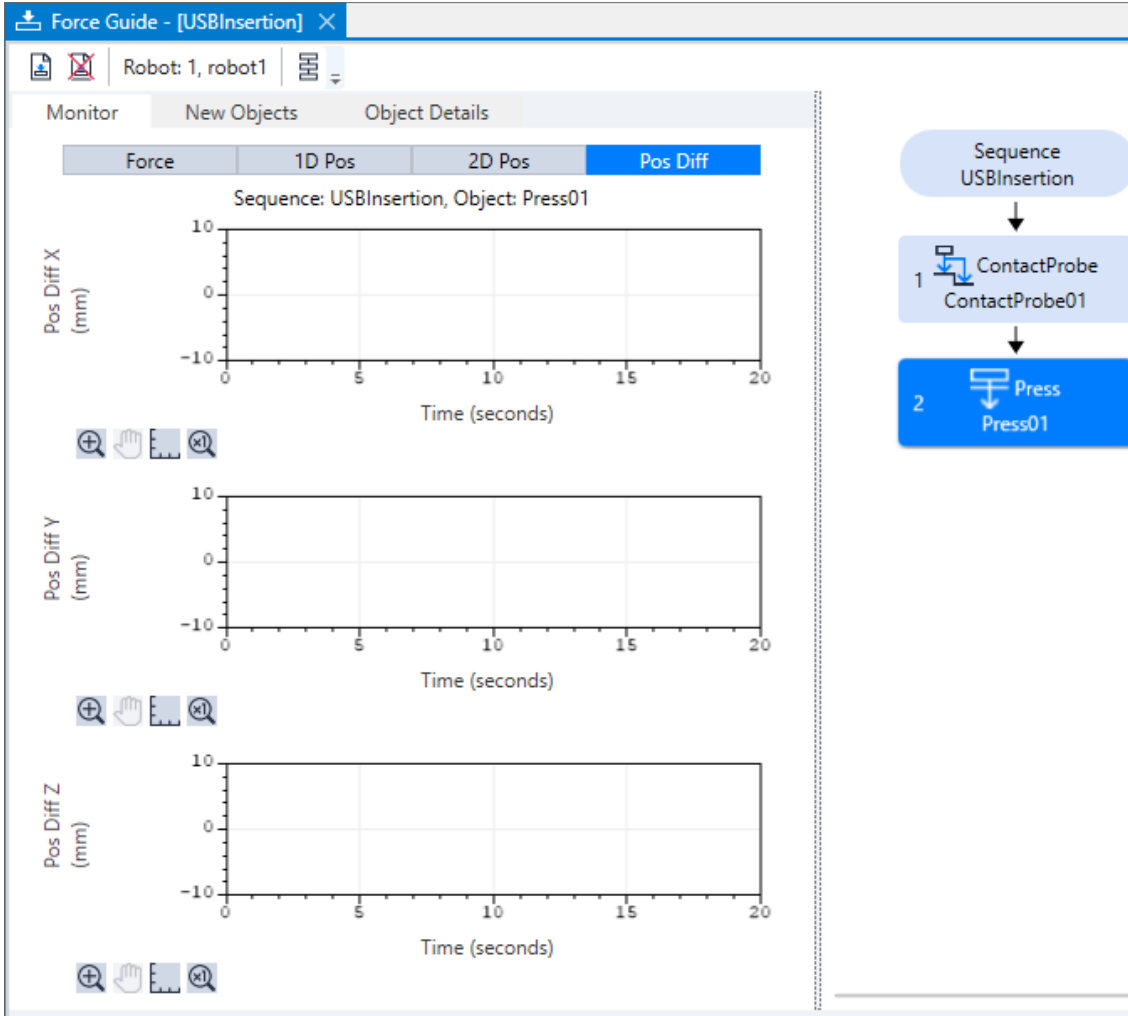

8. Change the unit of the graph and check the changes of force or positions.

If the connector is not connected properly, the setting may be not correct.

Refer to the following and check the procedures of the tutorial.

- Whether a pressing force direction is correct
- Whether a Plane setting is correct (relative position based on tool or base coordinate)
- Whether a start position is correct Or whether a position of height Z is not misaligned
- Whether a setting of [TimeOut] is too short.
- Whether a robot operates slowly in low power mode

4.6.2.2.9 Advanced Tasks

Let's do the following advanced tasks.

1. If the operation ends due solely to the condition "the condition is satisfied by the force when inserting a connector", the connector may have gotten snagged during insertion, and not been inserted completely.

As a remedy, add a position condition.

Change the [Press01 (Press)] property as shown below and execute it.

Check the difference from the last time. (Refer to: Software: [Press Object](#))

Item	Value	Description
EndCheckOperator	AND	Set AND as the end conditions related to force, position, and I/O.

Item	Value	Description
PosCheckEnabled	True	Enable the end conditions related to position.
PosCheckType	Relative Plane	Types of the end conditions related to positions . Make it an end condition that the robot moves a relative amount from the start point.
PlaneNumber	2	Overwrite Plane number 2 and use as the end condition of positions.
PlaneRelativeOrg	Tool	Indicate an offset amount to the origin of Plane based on the Tool coordinate system direction.
PlaneRelativeX	-10	Set an offset amount in each direction from the current position to the origin of Plane . Position is where the robot shifts -10 mm in the X direction based on the Tool coordinates.
PlaneRelativeY	0	
PlaneRelativeZ	0	
PlaneRelativeOrient	Tool	Set a coordinate system based on the Plane direction . Use the Tool coordinate system.
PlaneAxes	YZ	Set the plane direction to be parallel with the YZ plane in the tool coordinates . Normally, set Plane which is perpendicular to the robot motion direction.

Check the setting of [Plane] by using simulator.

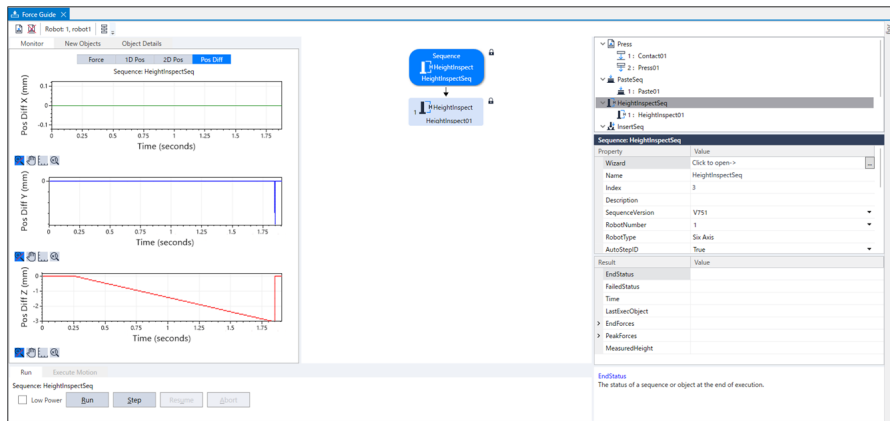

2. Perform the tool setting in the center of the contact area of a USB connector and execute this tutorial.

The force and torque values measured at this time are displayed based on the tool position.

When the right or left side of the USB connector contacts with the USB port, you can assume a tilt level of the USB connector grasped by the end effector by its positive and negative.

3. Increase motion speed.

The following properties affect to speed.

- Increase the [PressForce]. (However, connector's insertion force is set as specification. Change the force within the range.)
- Reduce [Firmness].
- Increase probe motion such as [SpeedS] or [AccelS] that affects to depart or travel time for moving to other probe positions.

Now, tutorial for "Insert USB connector" is completed.

4.6.2.3 Force Guidance Function (Peg In Hole)

The following describes how to operate "Peg In Hole" tasks that probes a hole using the cylinder while contacting the surface in spiral trajectory.

Prepare a workpiece by yourself.

Workpiece used in the picture is a training kit. If you need a drawing, please contact the supplier of your region. The specifications are as follows.

Cylinder on end effector side	Diameter: 20mm, Length 40mm
Hole side Diameter	approx. 20mm, C plane: approx. 7mm

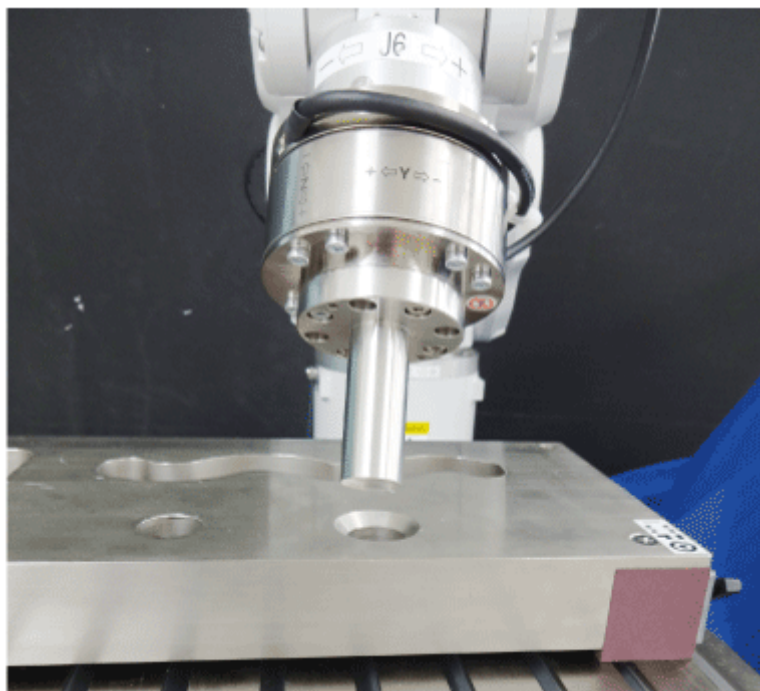

If you do not have a workpiece or a tool as shown above, you can try it easily by using a cylindrical wood, cork, and a plastic bottle. However, do not use a workpiece that has risks when it brakes such as a glass. Broken pieces will be scattered and may result in injury. Also, pay attention to surroundings when you proceed this tutorial.

CAUTION

The parameters described in the example on the following pages are reference values.

This tutorial uses relatively stable parameters, but depending on the operating environment, the operation may not be successful or the motion may be vibratory. Note that adjusting the parameters may be required. note that Slow, stable parameters are used for convenience of explanation. For high-speed operation, adjusting the parameters is required.

4.6.2.3.1 Sequence wizard

The following describes how to create a force guide sequence for Peg In Hole.

1. Enter "PegInHole" in [Enter name for new sequence]. Click the [Next] button.

Sequence Wizard

Step 1: General

Enter name for new sequence:
PegInHole

Select robot for new sequence:
1, robot1

Copy from existing sequence:

Cancel < Back Next > Teach... Finish

2. The [Step 2: Select sequence type] dialog box is displayed. Select [Template]. Click the [Next] button.

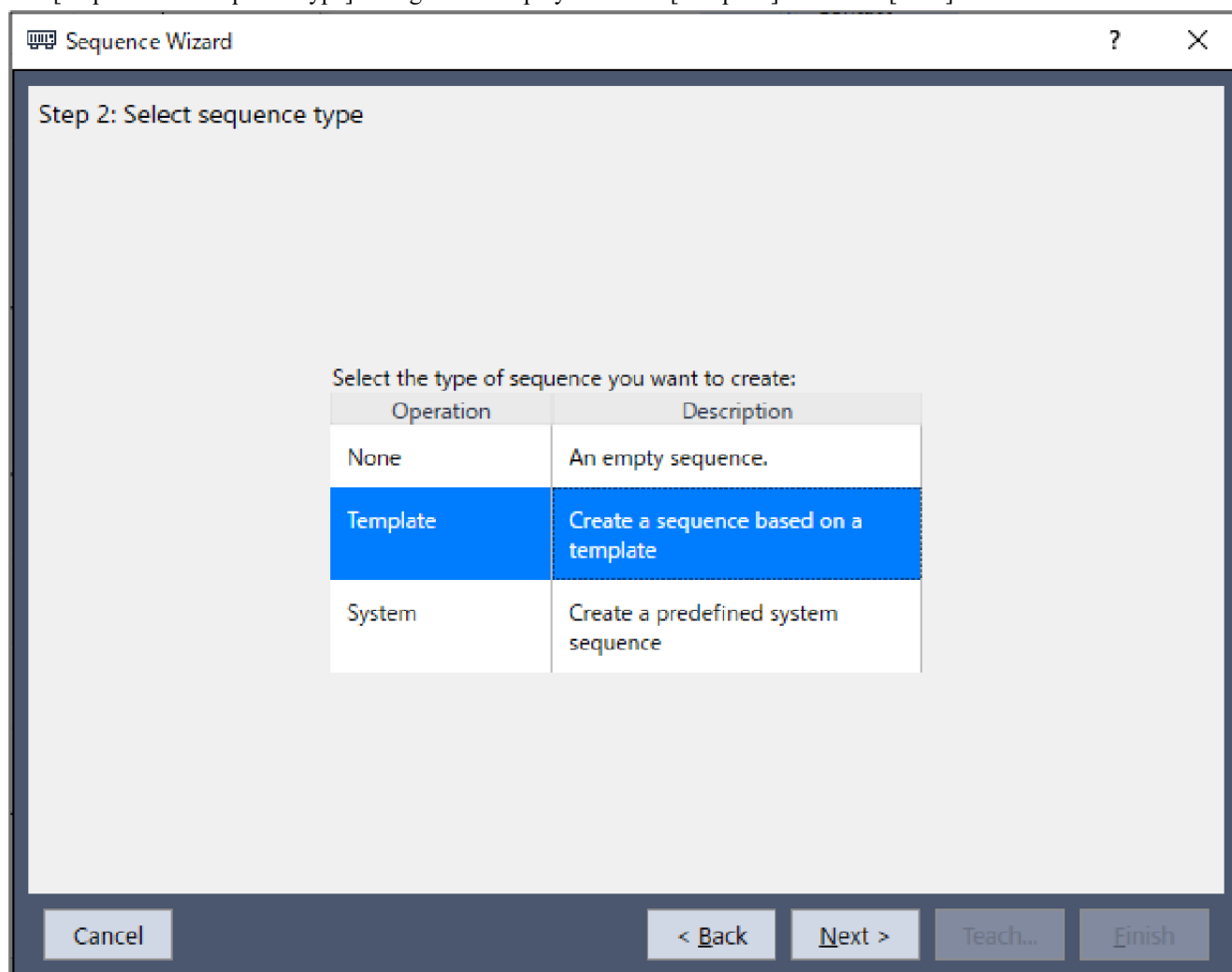

3. The [Step 3: Select type of force guidance operation you want to do] dialog box is displayed. Select [Peg In Hole]. Click the [Next] button.

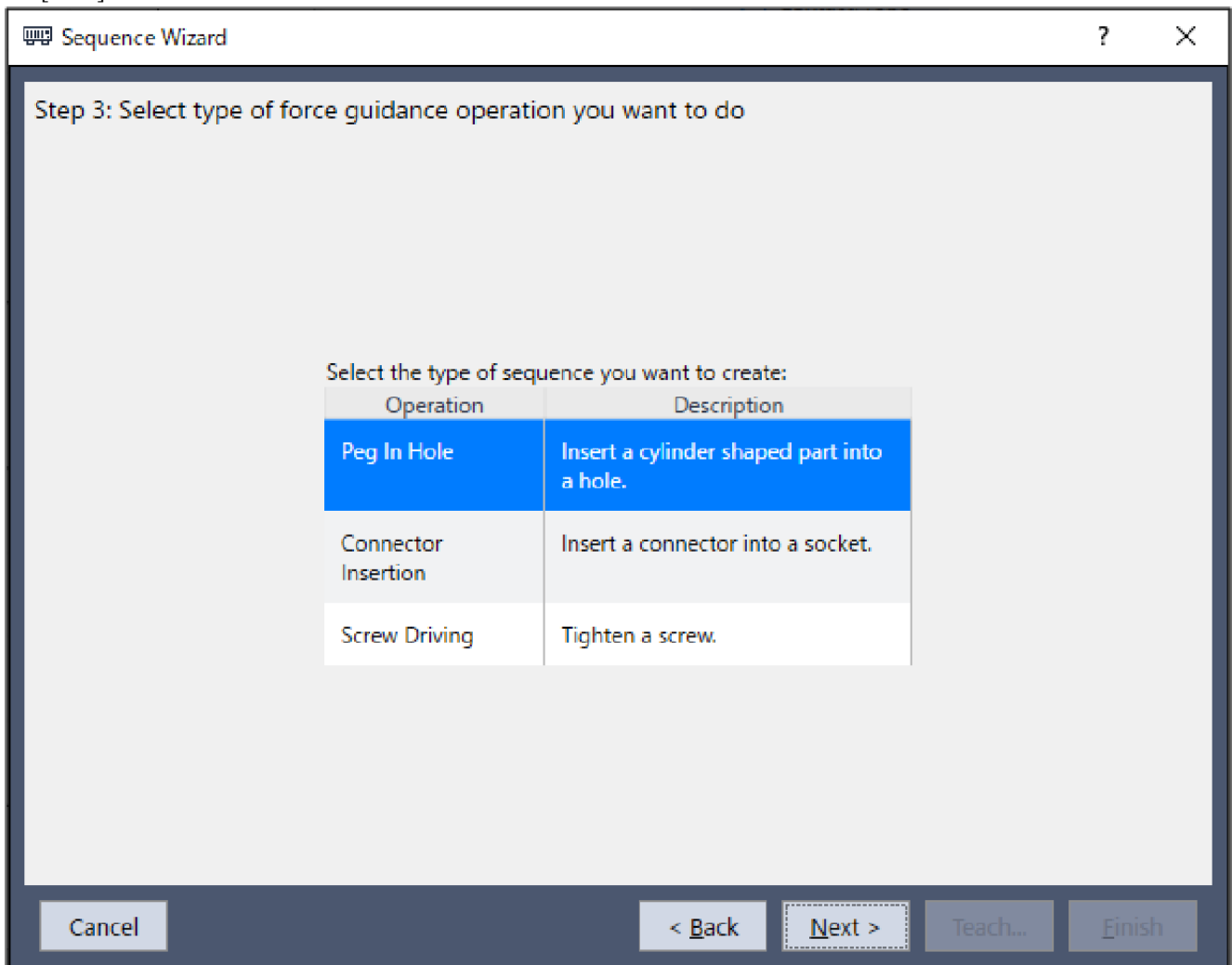

4. The [Step 4: Select the sequence template for the selected operation] dialog box is displayed. Select [With Probe]. Click the [Finish] button.

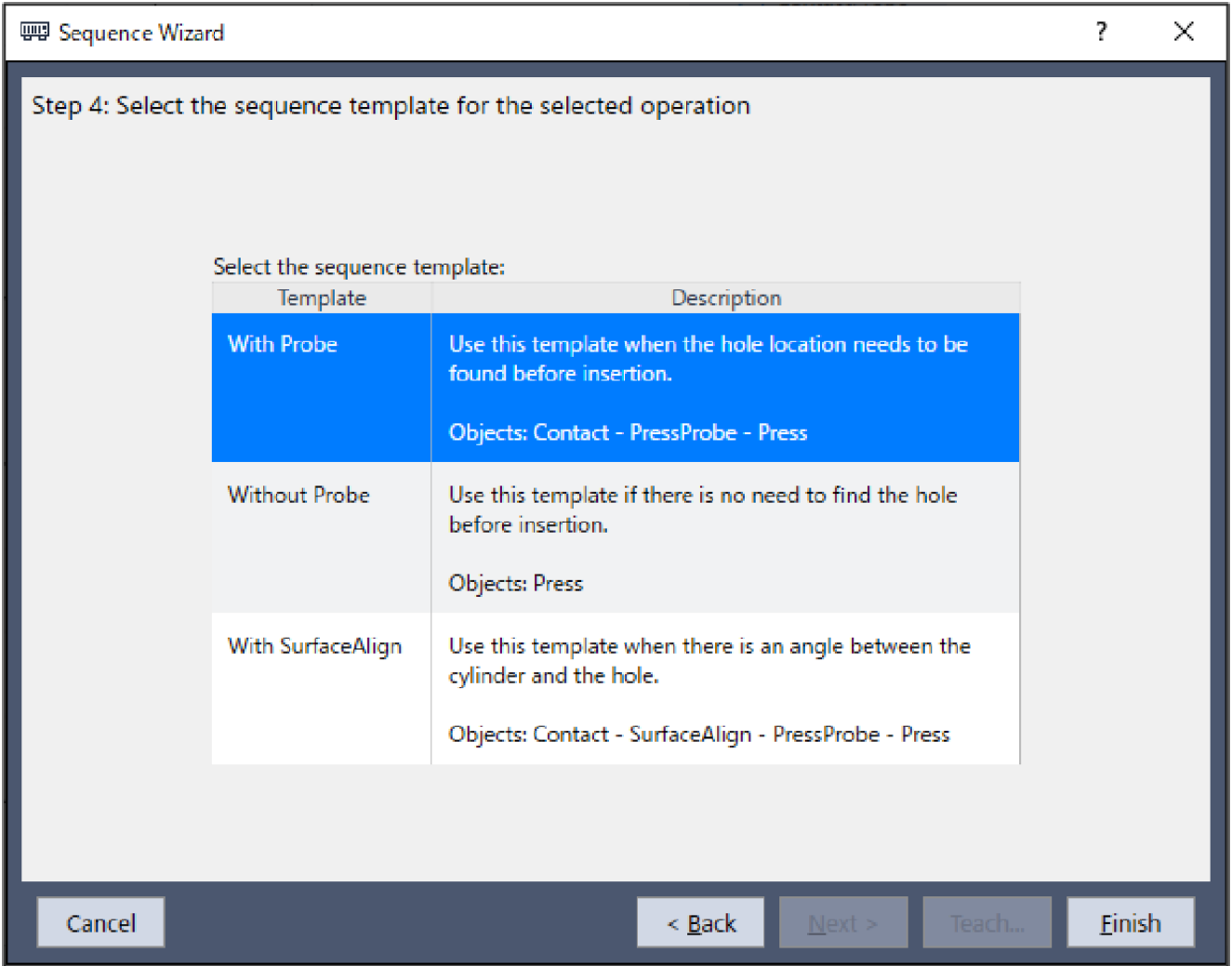

5. Confirm that the [PegInHole] sequence is created. Contact-PressProbe-Press

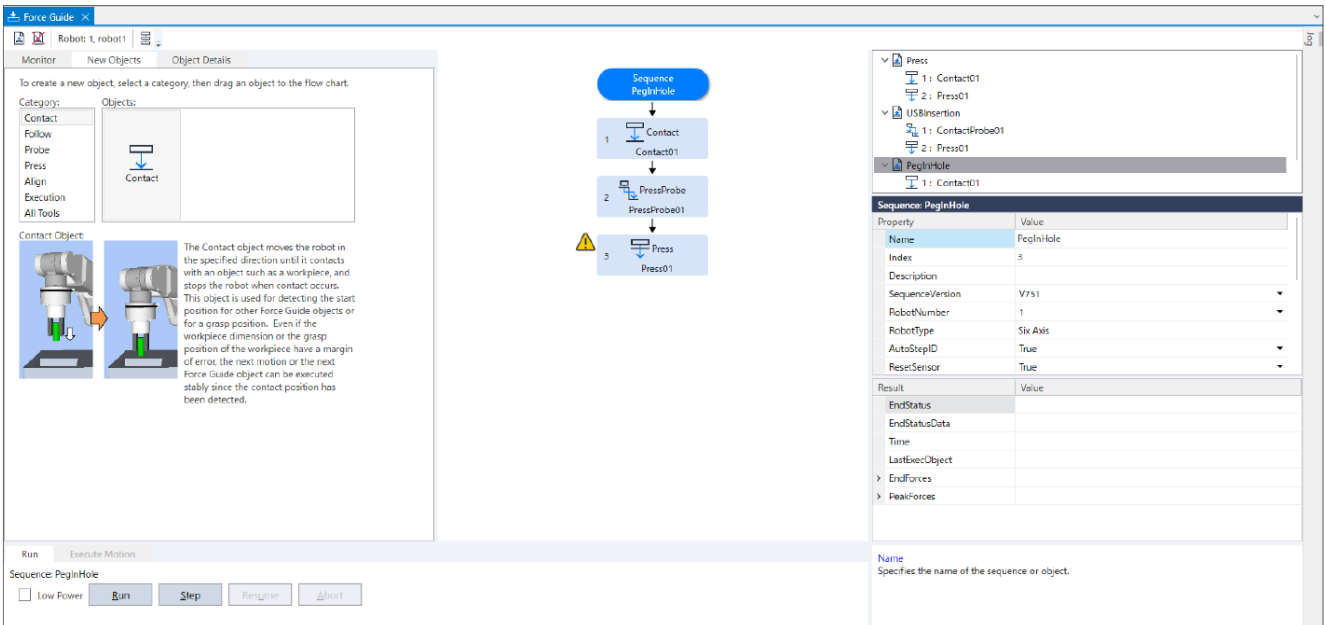

4.6.2.3.2 Tool Setting

During "Peg In Hole" task, the robot moves to X, Y, and Z directions while following to each rotation direction. Make sure to complete the tool setting when operating "Peg In Hole" task. Tool setting is also required when operating the surface align task.

Use a caliper to measure distance from J6 flange plane to the end of the cylinder. In the case of the following picture, the distance is 109mm. (Force Sensor: 49mm, End Effector: 60mm)

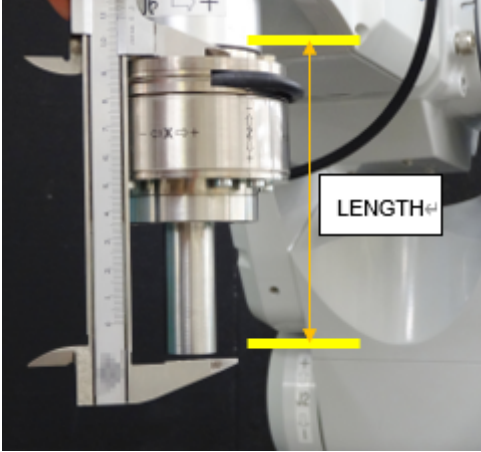

Execute the following command in [Command Window]. Enter the value measured in step (1) to "LENGTH". (unit: mm) Set and select Tool 2. > TLSet 2, XY(0, 0, LENGTH, 0, 0, 0) > Tool 2

Click Epson RC+ menu-[Tools]-[Simulator]. The [Simulator] window is displayed.

Click the object tree-[Tool].

Place a checkmark in the "No.2"-[Visible] check box.

Confirm the position and the orientation (direction) of Tool 2 by using the both simulator and the actual robot. If they are different, check the settings and reset Tool 1.

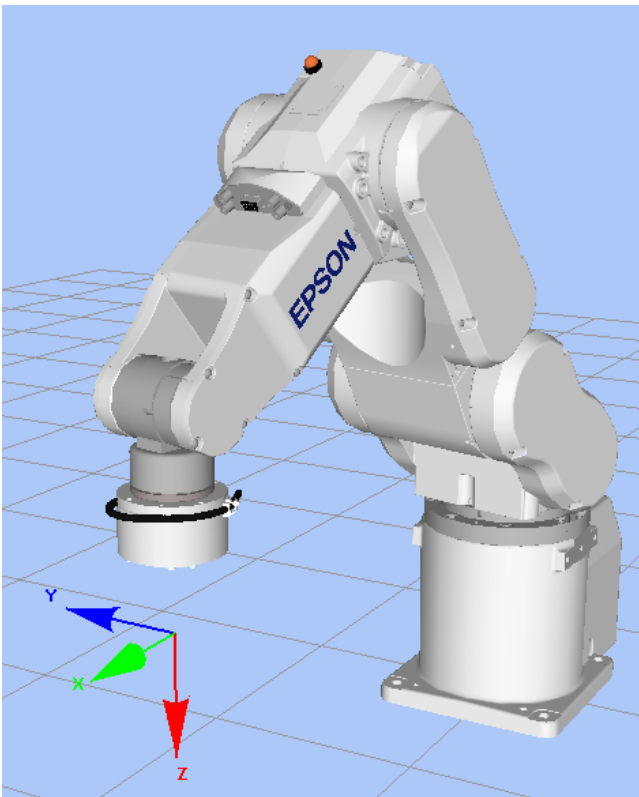

4.6.2.3.3 Position Teaching

The following describes how to teach a start position of the "Peg In Hole" task and a plane where the cylinder starts to fit.

1. Click Epson RC+ menu-[Tools]-[Robot Manager]. The [Robot Manager] dialog box appears.
2. Select [Jog & Teach] and open the panel.

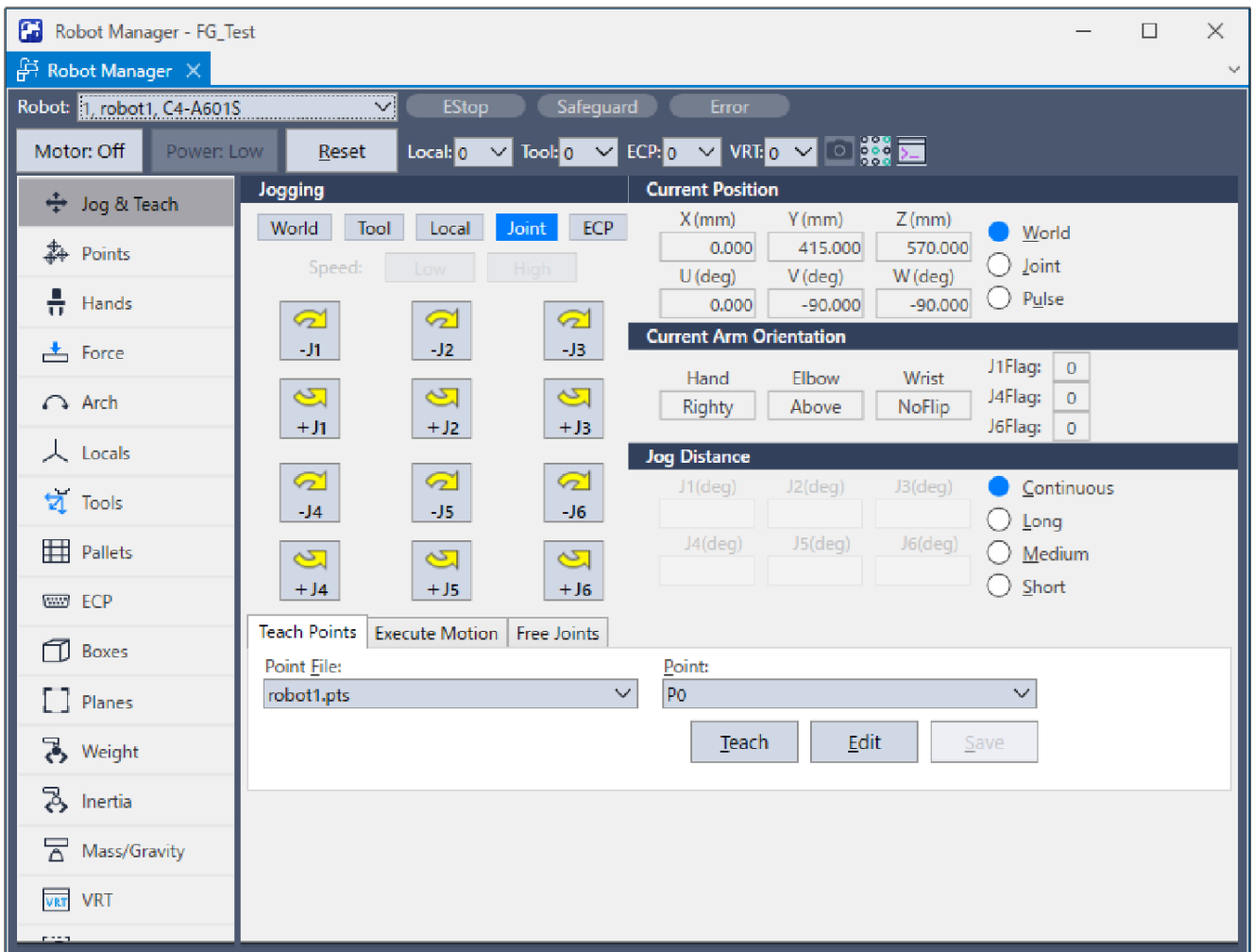

3. Select Epson RC+ menu-[Tools]-[Force Monitor]. The [Force Monitor] dialog box is displayed.
4. Click the [Start Live] button on the [Force Monitor] dialog box. Start to display the output value from the current Force Sensor.
5. Click the Jog button on the [Jog & Teach] window to move the robot to a position where the cylinder and the hole face each other.
Execute the following command in the command window if necessary.

```
> Go Align(Here)
```

By executing the above command, the robot will be a parallel orientation against the Base coordinate system based on the current position. The robot can move more easily when it and the contact point are facing one another.

For details, refer to the following manual: Epson RC+ SPEL+ Language Reference Align Function

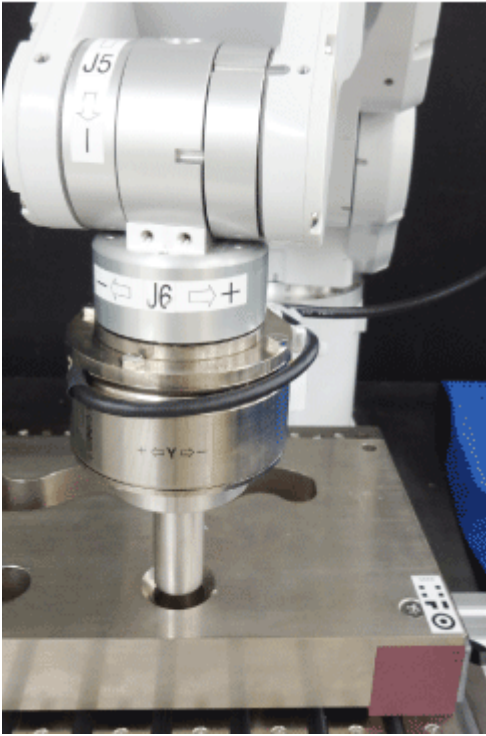

6. In the [Force Monitor] dialog box, click the [Reset Sensor] button. Eliminate the effect of gravity and drift of the sensor value, set the current position to "zero".
7. Click the Jog button on the [Jog & Teach] window to move the robot to a position where it is slightly away from the center of the insertion. To perform the pressing and probe motions, move the robot to a position where is slightly outside of taper (C plane).

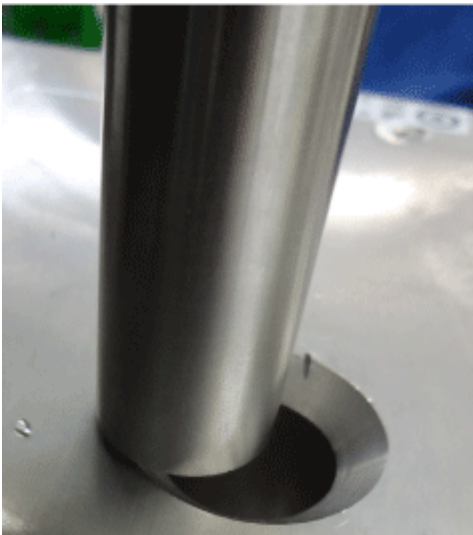

8. Select [Short] button on [Jog Distance]. Click the Jog button several times to move the robot to -Z direction until it contacts with an object near the hole. When the robot contacts with the object, output value of Force Sensor changes. Check the changes of monitor value by the timing of the jog motion.

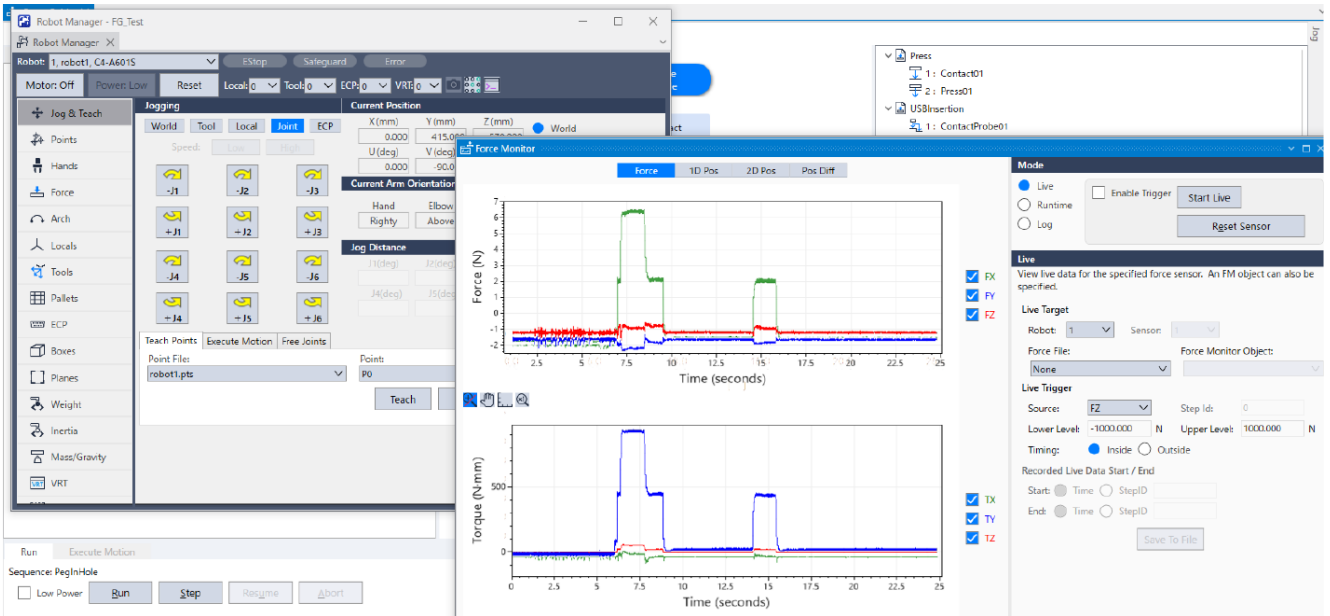

9. Select "P9" in the [Point] dropdown.
10. Click the [Teach] button.
11. The [New Point Information] dialog box is displayed. Enter "PegInHolePlane" to [Point Label] and click the [OK] button.
12. Select the [Medium] button on [Jog Distance].
Click the Jog button three times to move the robot 3mm in the +Z direction and put the cylinder into a non-contact state.

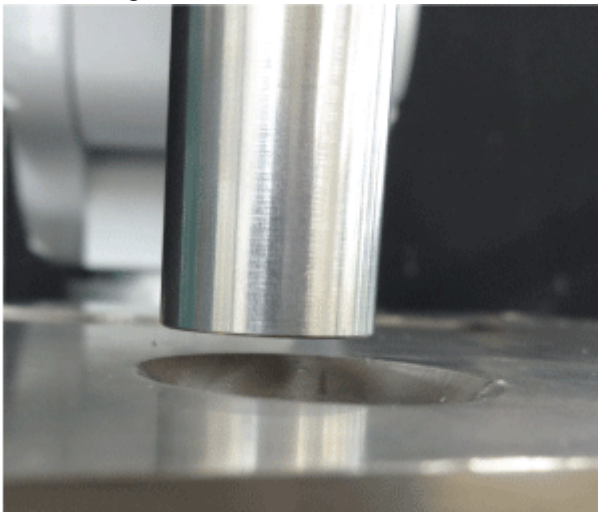



This is the start position for the insertion and the position where the Force Sensor is reset.

13. Select "P8" in the [Point] dropdown.
14. Enter "PegInHoleStart" in [Point Label]. Click the [OK] button.
15. Click Epson RC+ menu-[File]-[Save All]. The file is saved.

4.6.2.3.4 Property Setting

The following describes how to set the required properties for the "Peg In Hole".

1. The  mark is displayed on the flow chart by default. You need to set properties.

Move the mouse pointer onto the  mark to display the tool tips. The tool tips show settings or content which need to be modified.

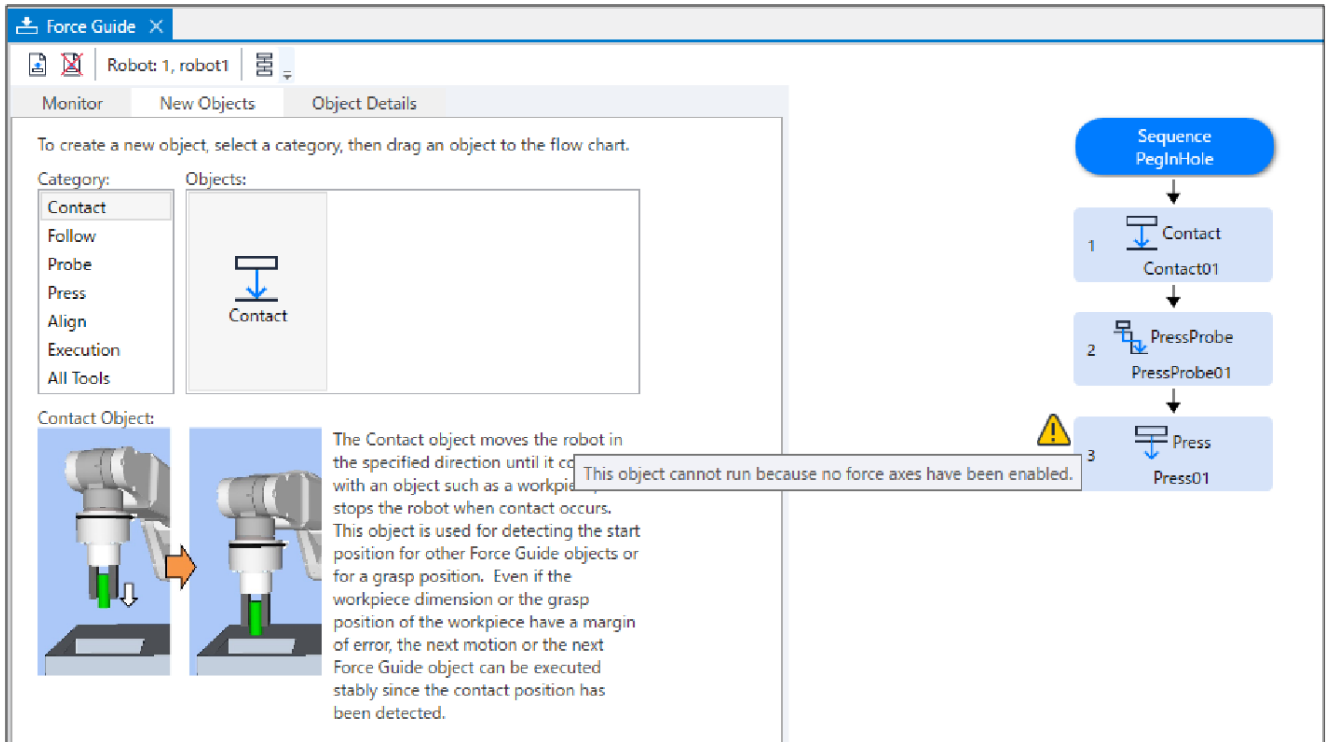

2. Select the [PegInHole] sequence. Properties and Results are displayed.
Change the following properties:



Item	Value	Description
RobotTool	2	Select Tool 2

3. Click Epson RC+ menu-[File]-[Save File]. Settings are saved.

4. Select the object flow of [Contact01] to display the properties.
Change the following properties:

Item	Value	Description
Contact - Orient *1	+Fz	Set a direction to contact. The robot moves to +Fz direction.
Contact - FirmnessF	2	Set a firmness of the force control functions.
Force End Condition - ContactForceThresh	-5	Set -5N to a threshold to determine a contact. Set this to a tolerable value considering the workpiece in use.
Timeout	10	Set a time-out period of a contact motion. When 10 seconds have passed until the robot contacts, it fails.

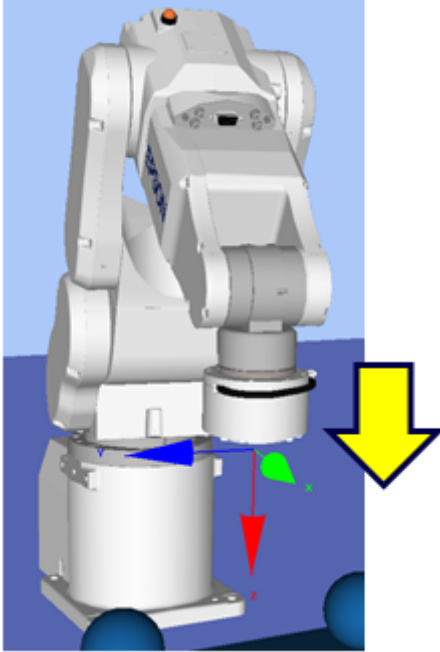
*1 [Reference]

	6-axis robot	SCARA robot
Robot motion image Pressing		
(Press/Contact) Orient	+Fz	-Fz
Sign of Force (monitor display is included)	-	+

5. Click Epson RC+ menu-[File]-[Save File]. Modified properties are saved to the project.

6. Select the object flow of [PressProbe01] to display the properties.

Change the following properties:

Item	Value	Description
ProbeTrajectory	Spiral	Set a trajectory to probe. Set Spiral trajectory.
ProbeDetectType	Hole	Set a target to be detected . Set Hole.
AccelS	100	Set the translational acceleration of the movement. Actual translational acceleration is adjusted by the force control functions. You need to set a large enough value such as ten times larger than SpeedS
SpeedS	10	Set the translational velocity of the movement. Actual translational velocity is adjusted by the force control functions. Set a value of about 10 mm/s.
SpiralDiam	30	Set a diameter of the spiral trajectory. Set this to 30mm.
SpiralPitch	3	Set the pitch of the spiral trajectory . Rotate around the center for ten times. Set this to 3mm.

Item		Value	Description
Press *1	Orient	+Fz	Direction to press. Set a vertical direction to a probe plane. *
	Force	-3	Set the pressing force. When PressOrient is a positive direction: Enter a negative value. When PressOrient is a negative direction: Enter a positive value. Normally, a value of approximately 3 to 5N is set. However, set a value that is proper for your workpiece. If the value is too small, the robot may move away from the probe plane.
	FirmnessF	1	Set a firmness of the force control functions in pressing direction.
PosEnd	PosCheckEnabled	True	Set whether to enable the end conditions related to positions.
Conditions *2	PosCheckType	Relative Plane	Select types of the end conditions related to positions. Every time the force guide sequence is executed, create Plane at a relative position from the current position and set as an end condition of position.
	PlaneNumber	3	Overwrite the Plane number 3 for end condition of positions.
	PlaneRelativeOrg	Tool	Indicate an offset amount to the origin of Plane based on the Tool coordinate system direction.
	PlaneRelativeZ	0.5	Set 0.5 mm to the Fz direction in the Tool coordinate system as an offset amount from the current position to the origin of Plane.
	PlaneRelativeOrient	Tool	Set a Plane direction
	PlaneAxes	XY	Create a Plane inside the XY plane in the Tool coordinate system.

7. Click Epson RC+ menu-[File]-[Save File]. Modified properties are saved to the project.

8. Select the object flow of [Press01] to display the properties.

Change the following properties:

Item		Value	Description
Fx	ControlMode	Follow	Perform the follow motion by the force control functions.
	Firmness	2	Set a firmness of the force control functions in X direction.
Fy	ControlMode	Follow	Perform the follow motion by the force control functions.
	Firmness	2	Set a firmness of the force control functions in Y direction.
Fz *1	ControlMode	Press+	Mode of force control function. Press+: The robot moves in the positive direction of the Fz axis and presses.
	Force	-10	Set an applied force when inserting. Set this to 10N.
	Firmness	2	Set a firmness of the force control functions in Z direction.

	Item	Value	Description
PosEnd Condition2 *2	PosCheckEnabled	True	Enable the end conditions related to position.
	PosCheckType	Relative Plane	Types of the end conditions related to positions. Every time the force guide sequence is executed, create Plane at a relative position from the current position and set as an end condition of position.
	PlaneNumber	3	Set Plane3 to the end condition of positions.
	PlaneRelativeOrg	Tool	Indicate an offset amount to the origin of Plane based on the Tool coordinate system direction.
	PlaneRelativeZ	10	Set an offset amount in Z direction from the current position to the origin of Plane. Direction will be the Tool coordinate system direction specified by PlaneRelativeOrg.
	PlaneRelativeOrient	Tool	Set a coordinate system based on the Plane direction to the Tool coordinate system.
	PlaneAxes	XY	Set XY plane as the plane direction.
TimeOut		20	Set the time-out duration. Fails when the end condition (move 10mm) is not satisfied within 20 seconds.

9. Click Epson RC+ menu-[File]-[Save File]. Modified properties are saved to the project.

*2 [Reference] Positional relationship with Plane

The positional relationship of the robot's current position and Plane is as shown below. If the robot's current position is in the +Z direction area from the Plane origin, it will be "Inside".

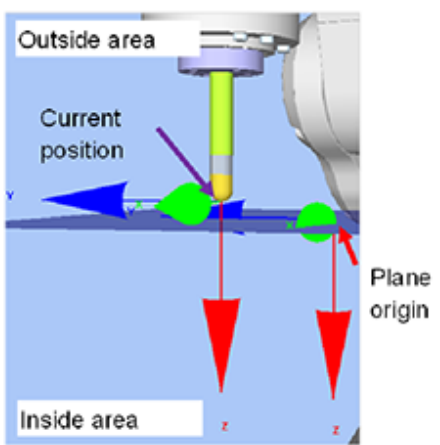
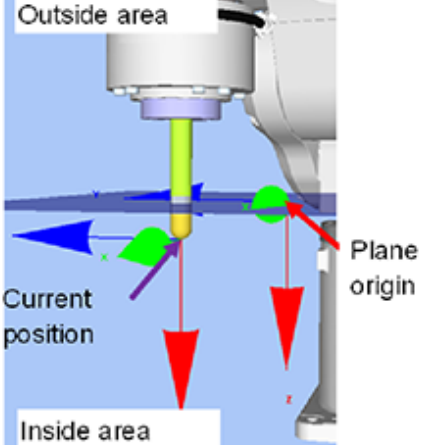
	Outside	Inside
Positional relationship with Plane 6-axis robot		
Determined value of Plane (GetRobotInsidePlane)	0 = Outside	1 = Inside

4.6.2.3.5 Setting Confirmation

The following describes how to check whether the settings for the pressing direction are correct by using a simulator. Click Epson RC+ menu-[Tools]-[Simulator]. The [Simulator] window is displayed.

Click the object tree-[Force]-[Force Guide]-[PegInHole].

Place a checkmark on the following checkboxes. [Contact01]-[Visible], [PressProbe01]-[Visible], [Press01]-[Visible]

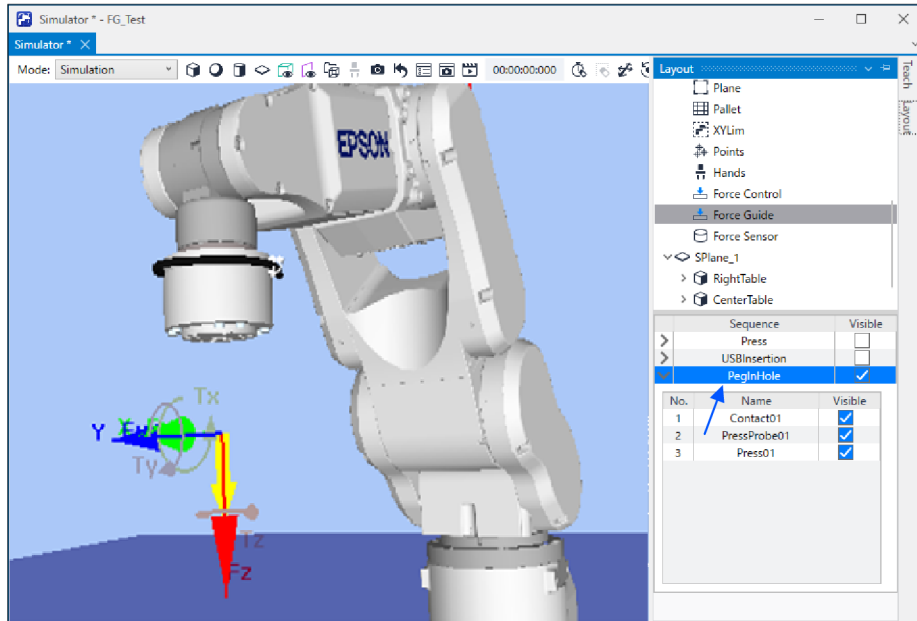

Confirm that the yellow arrow direction is the same as the cylinder insertion direction. If the direction is different, refer to the following section and check the setting.

Software [Property Setting](#)

4.6.2.3.6 Motion by Force Guidance Function

The following describes how to execute a sequence that performs "Peg In Hole" task in the [Force Guide] window.

1. Open the [Force Guide] window.
2. Click the [Execute] button.

Program is compiled and transmitted to the Robot Controller.

If the setting is not correct, an error occurs. Check the settings so far and follow the error message to modify the parameters.

3. When the program satisfies the conditions set in the properties and can be executed to the end, "✔" is displayed on the upper left of the flowchart and the robot motion stops.

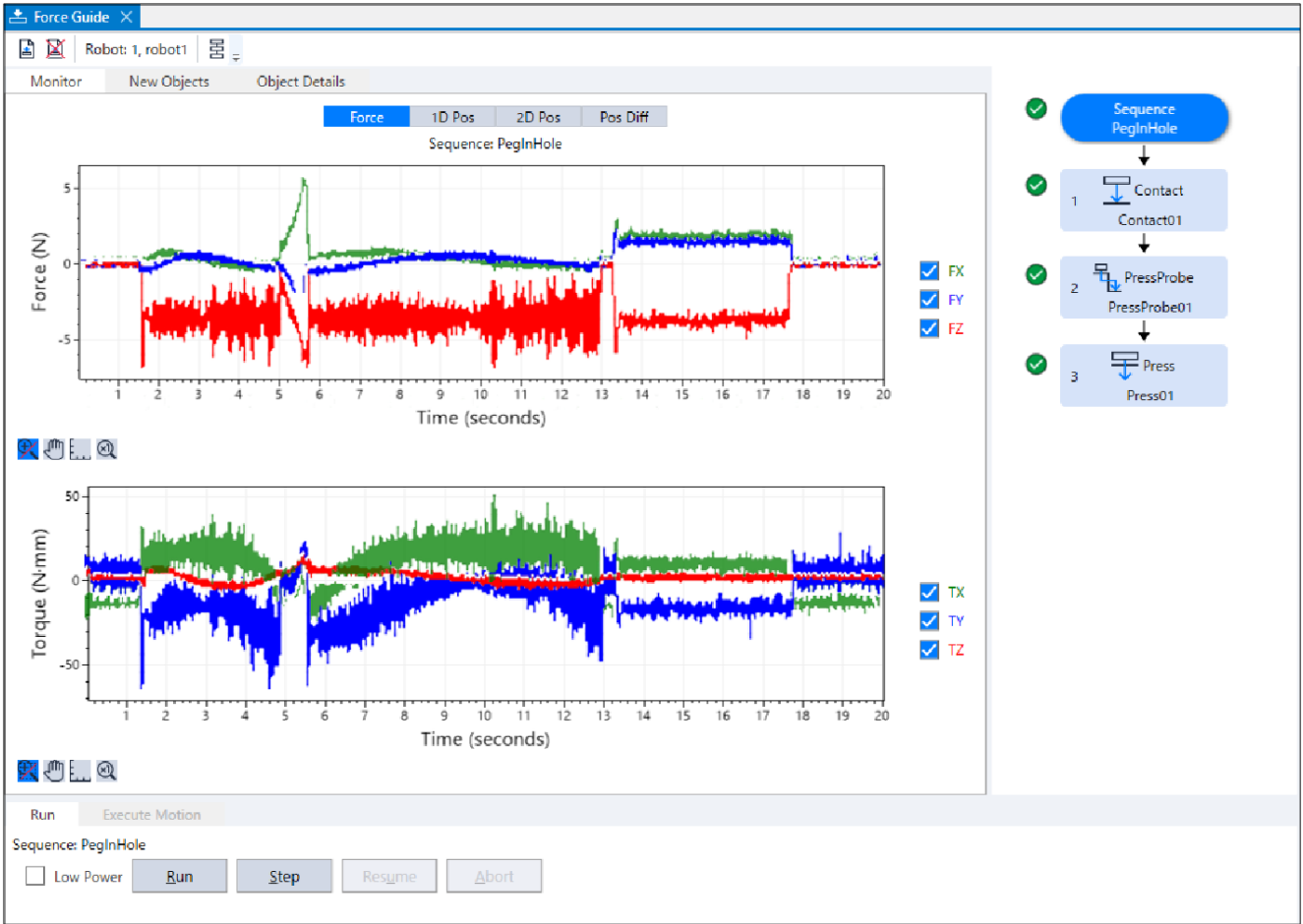

4.6.2.3.7 Return to the Non-Contact State

The following describes how to return to the non-contact state.

Force to perform the Peg In Hole task is still applied even the task is completed. If you operated an accurate Peg In Hole task such as an interval is tens of microns, large force may be applied even the task is in the end state.

To prevent the robot and the end effector from malfunction or damages, move the robot away from the object immediately after the operation ends, and make sure that no force is applied to the object. If it is obvious that no force is applied to the object, you can omit this step.

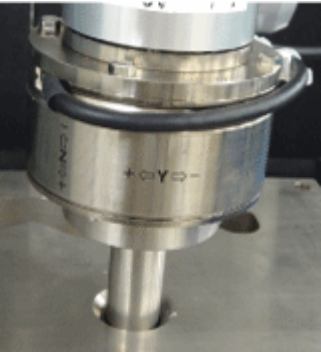

- Operate the jog motion for small distances such as 0.1 mm and set the robot to a non-inserting state.
- Make the cylinder to be non-grasped state.

- Create a force guide sequence that performs "pulling" (press in the opposite direction to the insertion) separately and pull the stick out. When five minutes have passed after the insertion task, you may not be able to pull the stick out since the detection values shift due to drift of the Force Sensor. For more details, refer to the following section.

Software: [Advanced Tasks](#) - 2

In this tutorial, pull the stick out by the jog motion while checking on the force monitor.

1. Select Epson RC+ menu-[Tools]-[Force Monitor]. The [Force Monitor] dialog box is displayed.
2. Select the [Start Live] button. Graph of the currently selected force monitor object is displayed.
3. Display the [Robot Manager] dialog box.
4. Select the [Jog & Teach] panel.
5. Click [Jogging]-[Mode] and select "Tool". It is a proper setting for removing perpendicular to the hole when the Peg In Hole task is performed to the hole with tilt while performing the follow motion.
6. Select [Short] button on [Jog Distance].
7. Move the robot in the -Z direction 0.1 mm at a time.

Output value will be far from "0" with time due to the drift characteristic of the Force Sensor. Relative changes of the force value are reflected the contact state changes correctly.

While checking the graph values to be displayed, click the Jog button to move the robot to X, Y direction. The robot will be to non-contact state.

Reference: Software [Resetting the Force Sensor](#)

[Reference] The [Jog] tab is in the [Force Guide] window. When you select this tab, the [Jog] window is displayed. You can move the robot and set to non-contact state by clicking the Jog button.

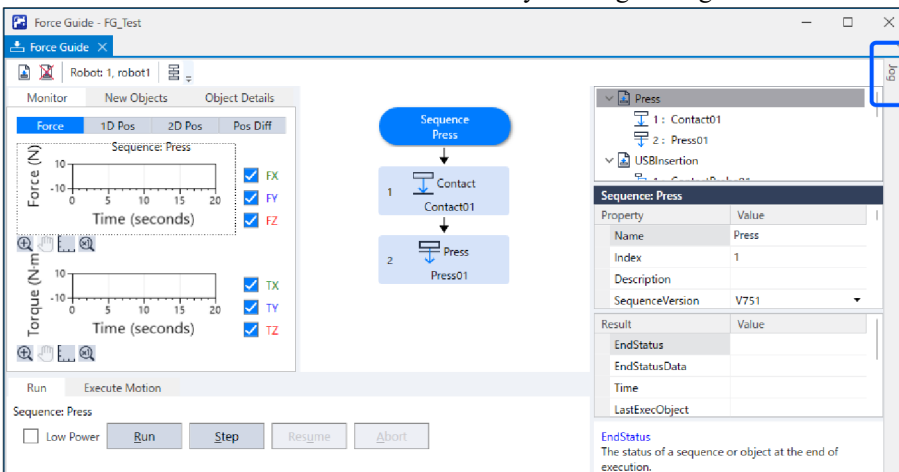

4.6.2.3.8 Motion Analysis by Monitor

The following describes how to use Epson RC+ to check the operation results of a force guide sequence.

Display the [Force Guide] window.

Click the sequence flow of [PegInHole].

Select the [Monitor] tab. Select the [Force] tab. Force and position during the [PegInHole] sequence execution are displayed in the graph.

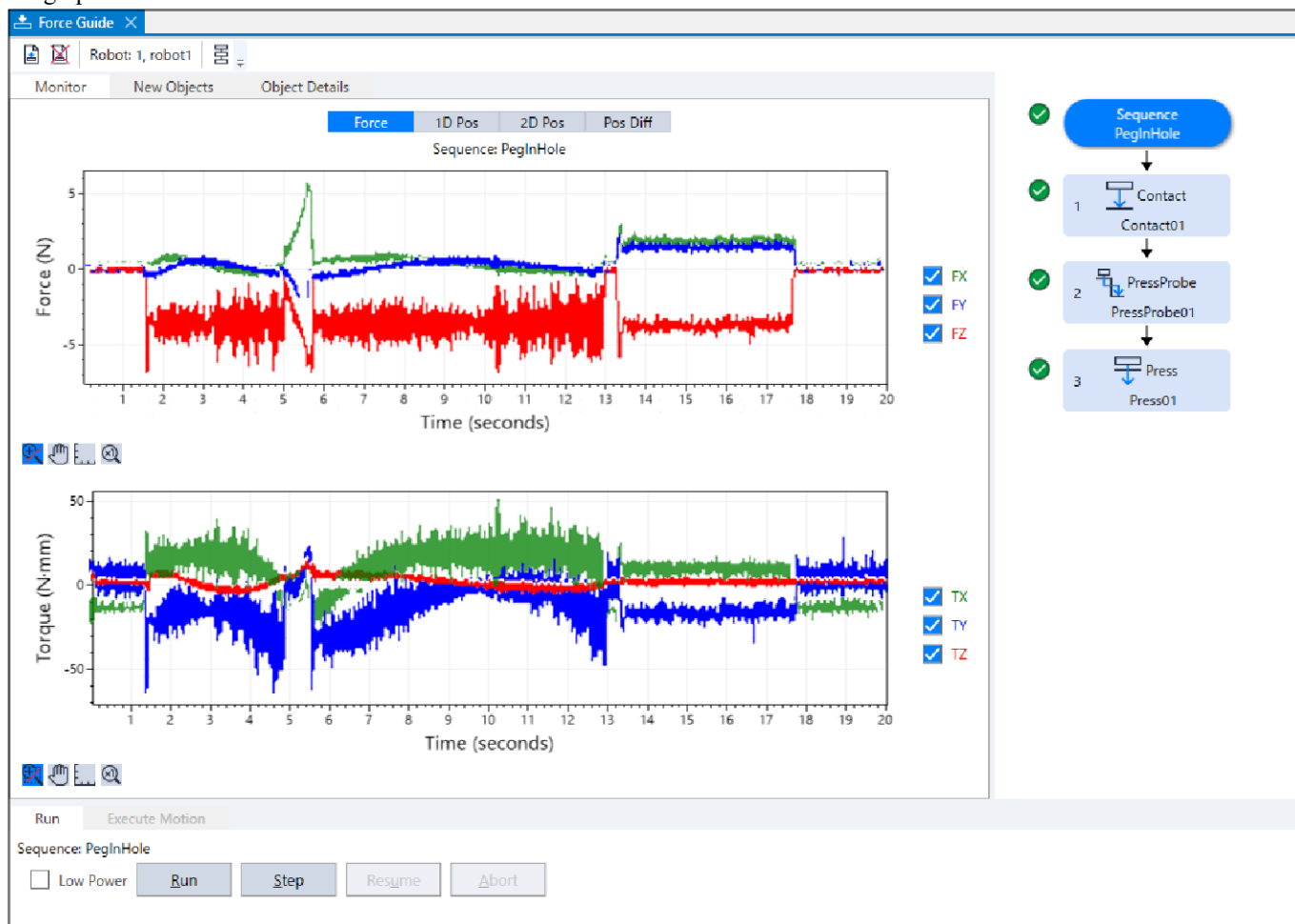

Click the object flows of [Step1], [Step2], and [Step 3] to display the force and the position during the execution of the selected force guide object.

The screenshot displays the Force Guide software interface for a robot named "Robot: 1, robot1". The main window is titled "Force Guide" and has tabs for "Monitor", "New Objects", and "Object Details". The "Object Details" tab is active, showing a "Force" graph and a "Torque" graph. The "Force" graph plots Force (N) on the y-axis (ranging from -5 to 5) against Time (seconds) on the x-axis (ranging from 0 to 9.5). It shows three data series: FX (green), FY (blue), and FZ (red). A significant spike in force occurs at approximately 3.5 seconds. The "Torque" graph plots Torque (N*mm) on the y-axis (ranging from -50 to 50) against Time (seconds) on the x-axis (ranging from 0 to 9.5). It shows three data series: TX (green), TY (blue), and TZ (red). A significant spike in torque also occurs at approximately 3.5 seconds. To the right of the graphs is a sequence flow diagram with four steps: "Sequence PegInHole", "1 Contact Contact01", "2 PressProbe PressProbe01", and "3 Press Press01". The "2 PressProbe PressProbe01" step is highlighted in blue. At the bottom of the interface, there are buttons for "Run", "Execute Motion", "Low Power", "Run", "Step", "Resume", and "Abort".

Click the sequence flow of [PegInHole]. Select the [Monitor] tab. Select the [1D Pos] tab. Graph for analysis is displayed. (horizontal axis: Time, vertical axis: Position)

The screenshot displays the Force Guide software interface. At the top, the window title is 'Force Guide'. Below it, the 'Robot: 1, robot1' is selected. The 'Monitor' tab is active, and the '1D Pos' sub-tab is selected. The main area contains three graphs showing Position (mm) vs. Time (seconds) for the 'Sequence: PegInHole'.

- Position X (mm):** The graph shows a red line for 'CurX' and a blue line for 'RefX'. The red line starts at 0, peaks at approximately 5 mm around 7.5 seconds, and then drops to -10 mm by 12 seconds. The blue line starts at 0 and remains at 0 until 12 seconds, then rises to approximately 5 mm by 18 seconds.
- Position Y (mm):** The graph shows a red line for 'CurY' and a blue line for 'RefY'. The red line starts at 0, peaks at approximately 5 mm around 5.5 seconds, and then drops to -5 mm by 10 seconds. The blue line starts at 0 and remains at 0 until 12 seconds, then rises to approximately 10 mm by 18 seconds.
- Position Z (mm):** The graph shows a red line for 'CurZ' and a blue line for 'RefZ'. The red line starts at 10 mm, drops to 5 mm at 1.5 seconds, and remains constant until 12 seconds. The blue line starts at 10 mm and remains constant until 12 seconds, then drops to -10 mm by 18 seconds.

At the bottom of the interface, there is a 'Run' section with 'Execute Motion' and 'Sequence: PegInHole'. Below this are buttons for 'Low Power', 'Run', 'Step', 'Resume', and 'Abort'. On the right side, a sequence flow diagram is shown, consisting of three steps:

1. Contact (Contact01)
2. PressProbe (PressProbe01)
3. Press (Press01)

Select the [2D Pos] tab. Graph for analysis is displayed. (horizontal axis, vertical axis: Position) Focus on the blue line. You can see that the robot enters into a hole while the spiral probe motion and the motion switches to the pressing motion. Then, the robot moves to -Z direction and moves (follows) inside the X, Y plane.

The screenshot displays the Force Guide software interface for a robot sequence named "PegInHole". The interface is divided into several sections:

- Top Bar:** "Force Guide" window title, "Robot: 1, robot1", and navigation tabs: "Monitor", "New Objects", "Object Details".
- Graphs:** Three 2D position graphs are shown under the "2D Pos" tab. The "Sequence: PegInHole" label is above them.
 - XY plane from +Z axis view:** Shows Position Y (mm) vs Position X (mm). A red spiral line represents the reference position, and a blue line represents the current position.
 - YZ plane from +X axis view:** Shows Position Z (mm) vs Position Y (mm). A red horizontal line represents the reference position, and a blue line shows the current position moving downwards and then along the Y-axis.
 - XZ plane from +Y axis view:** Shows Position Z (mm) vs Position X (mm). A red horizontal line represents the reference position, and a blue line shows the current position moving downwards and then along the X-axis.
- Legend:** Located below the graphs, it indicates that a blue line represents "Current Position" and a red line represents "Reference Position".
- Sequence Flowchart:** On the right side, a vertical flowchart shows the sequence steps:
 - Step 0: "Sequence PegInHole" (blue rounded rectangle).
 - Step 1: "Contact" (light blue rounded rectangle) with sub-label "Contact01".
 - Step 2: "PressProbe" (light blue rounded rectangle) with sub-label "PressProbe01".
 - Step 3: "Press" (light blue rounded rectangle) with sub-label "Press01".Each step is preceded by a green checkmark icon.
- Bottom Bar:** Includes a "Run" button, "Execute Motion" text, and a "Sequence: PegInHole" label. Below this is a "Low Power" checkbox and four buttons: "Run", "Step", "Resume", and "Abort".

Select the [Pos Diff] tab. Record shifts by force control as relative position changes. It is different from the graph on the [1D Pos] tab.

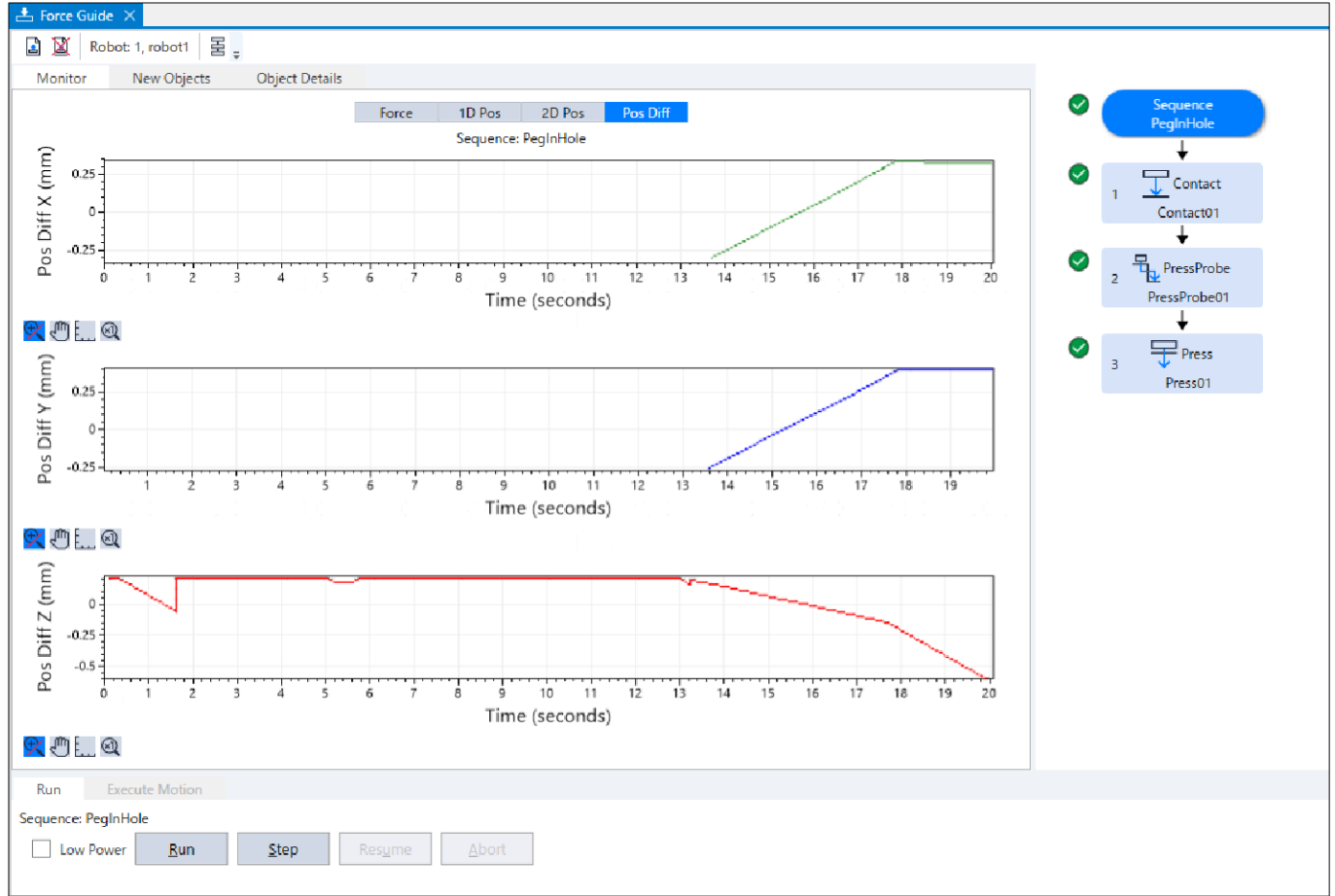

Change the unit of the graph and check the changes of force or positions.

Look the monitor shown by Tutorial and check the motion results. since the robot nearly entered a hole in [Step2]; however, it could not move downward more than 0.5mm, which is set in the position setting of [Plane Z].

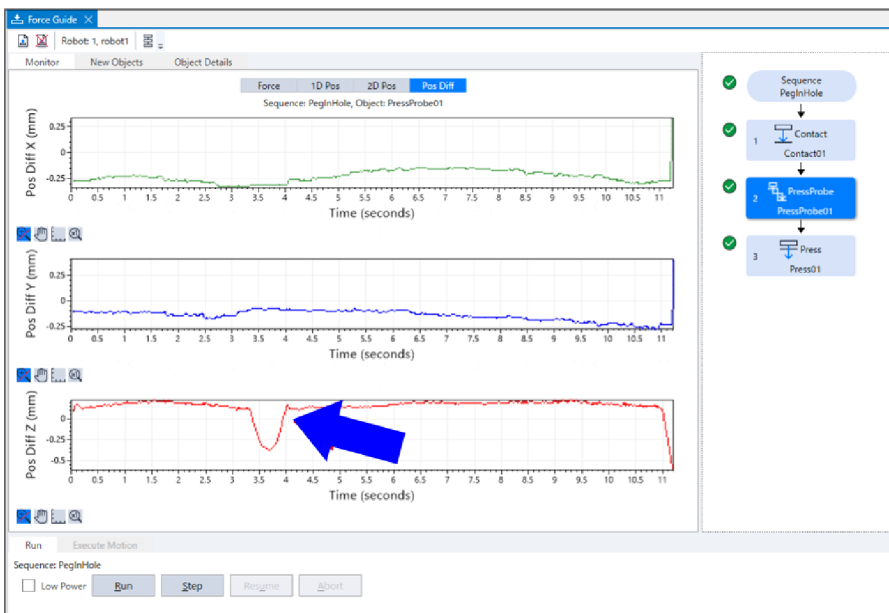

4.6.2.3.9 Advanced Tasks

Let's do the following advanced tasks.

1. When you perform a probe motion, task takes longer to do, since time for the probe motion is added.
If you can omit the probe motion, task time can be shortened.
Follow the steps below to try.
 - i. Change the position of task start position (taught point: PegInHoleStart) to the inside of the taper (C plane).
 - ii. Right-click [Step 2: PressProbe] and select [Delete].
 - iii. Refer to the following and execute the force control function.
Software **Motion by Force Guidance Function**
2. It takes a long time to perform jog motion for a distance of tens of millimeters, as in "Software **Return to the Non-Contact State.**"
Let's try a method to pull the stick out using the force control function right after the Peg In Hole task. At this time, make sure not to reset the Force Sensor by clicking [Sequences]-[Property].

CAUTION

When about five minutes have passed after Peg In Hole task, the robot cannot detect a proper value and fails to pull the stick out due to the drift characteristics of Force Sensor. At this time, a large force will be applied to the workpiece and it may result in damage to workpiece. Be sure to pull the stick out right after the force guide sequence is executed.

If you reset the Force Sensor in the contact state, the force and value at that time will be "0". In this state, the force control function cannot be performed properly and the robot may fail to pull the stick out or the workpiece may get damage. Be sure to set the [ResetSensor] property to "False". Also, when you want to reset the Force Sensor (e.g. click the [Reset Sensor] button or reboot the Controller), move the robot by using the jog motion without performing the force control function and set to the non-insertion state / the non-grasped state.

1. Create another empty force guide sequence which is different from [PegInHole].
Example: PullFromHole
2. Add a Press object only and set the properties.
For 6-axis robot, refer to the following settings and adjust the properties such as [Firmness].
 - Set the "Press-" direction in [Fz_ControlMode]
 - Set "Follow" in [Fx_ControlMode], [Fy_ControlMode]
 - Set a force of less than 10 N in [Fz_ControlMode]
(If the force is too great, the robot may get caught in the hole.)
 - Set a large value in [Timeout] such as 60 sec.
(Robot keeps moving even when the "pulling" task is performed. Click the [Abort] button to stop the robot.)
 - Set [Fx_Firmness], [Fy_Firmness], and [Fz_Firmness] to the same object as [Press01] of [PegInHole].
3. Click the sequence flow in the flowchart.
4. Set the [ResetSensor] property to "False".
5. Refer to the following and execute the force control function.
Motion by Force Guidance Function

Now, tutorial for "Peg In Hole" is completed.

4.6.2.4 Force Guidance Function (Screw Driving)

The following describes how to perform screw driving task.

Please prepare an electric screwdriver, screws, and workpiece to fix screws by yourself. Incorrect settings may result in damage of the workpieces. Prepare workpieces that can be damaged, and proceed with this tutorial.

Make sure to set the position of workpiece or screw driving direction as same as the picture below.

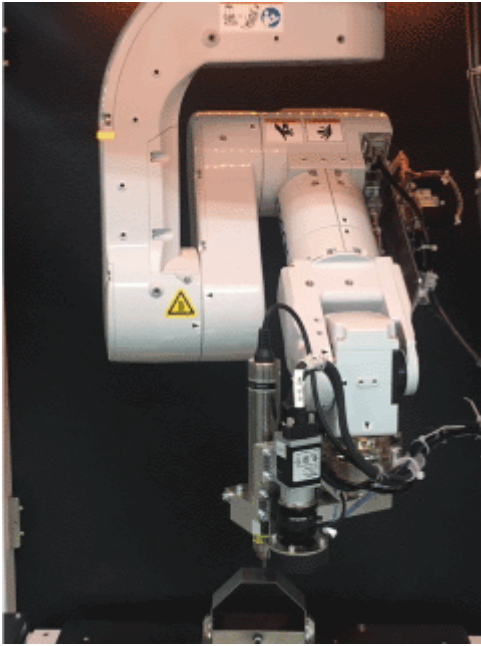

⚠ CAUTION

The parameters described in the example on the following pages are reference values.

This tutorial uses relatively stable parameters, but depending on the operating environment, the operation may not be successful or the motion may be vibratory. Note that adjusting the parameters may be required. note that Slow, stable parameters are used for convenience of explanation. For high-speed operation, adjusting the parameters is required.

4.6.2.4.1 Sequence wizard

The following describes how to create a force guide sequence for "Screw Driving".

1. Enter "ScrewUp" in the [Enter name for new sequence] box. Click the [Next] button.

Sequence Wizard

Step 1: General

Enter name for new sequence:
ScrewUp

Select robot for new sequence:
1, robot1

Copy from existing sequence:

Cancel < Back Next > Teach... Finish

2. The [Step 2: Select sequence type] dialog box is displayed. Select [Template]. Click the [Next] button.

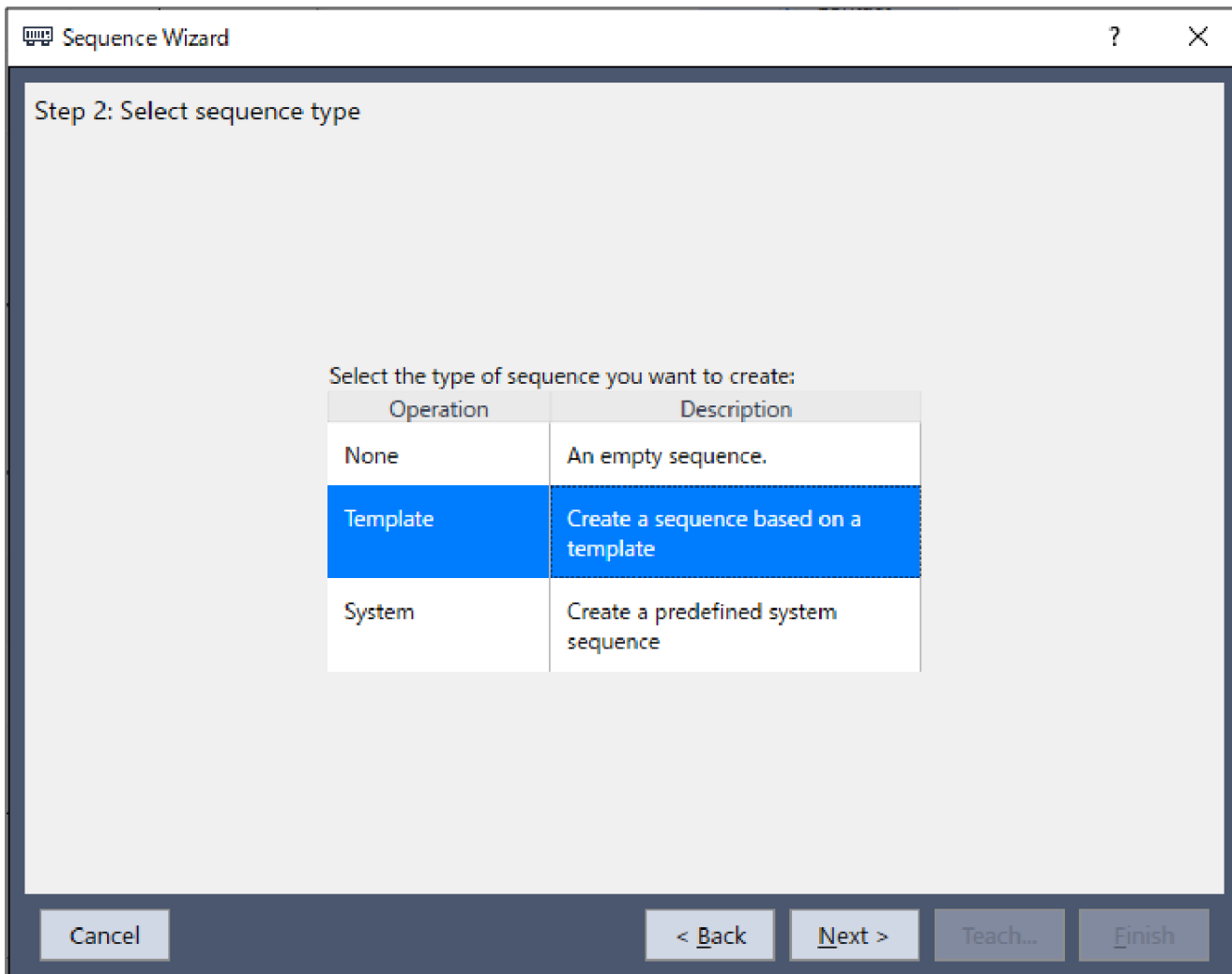

3. The [Step 3: Select type of force guidance operation you want to do] dialog box is displayed. Select [Tighten screw]. Click the [Next] button.

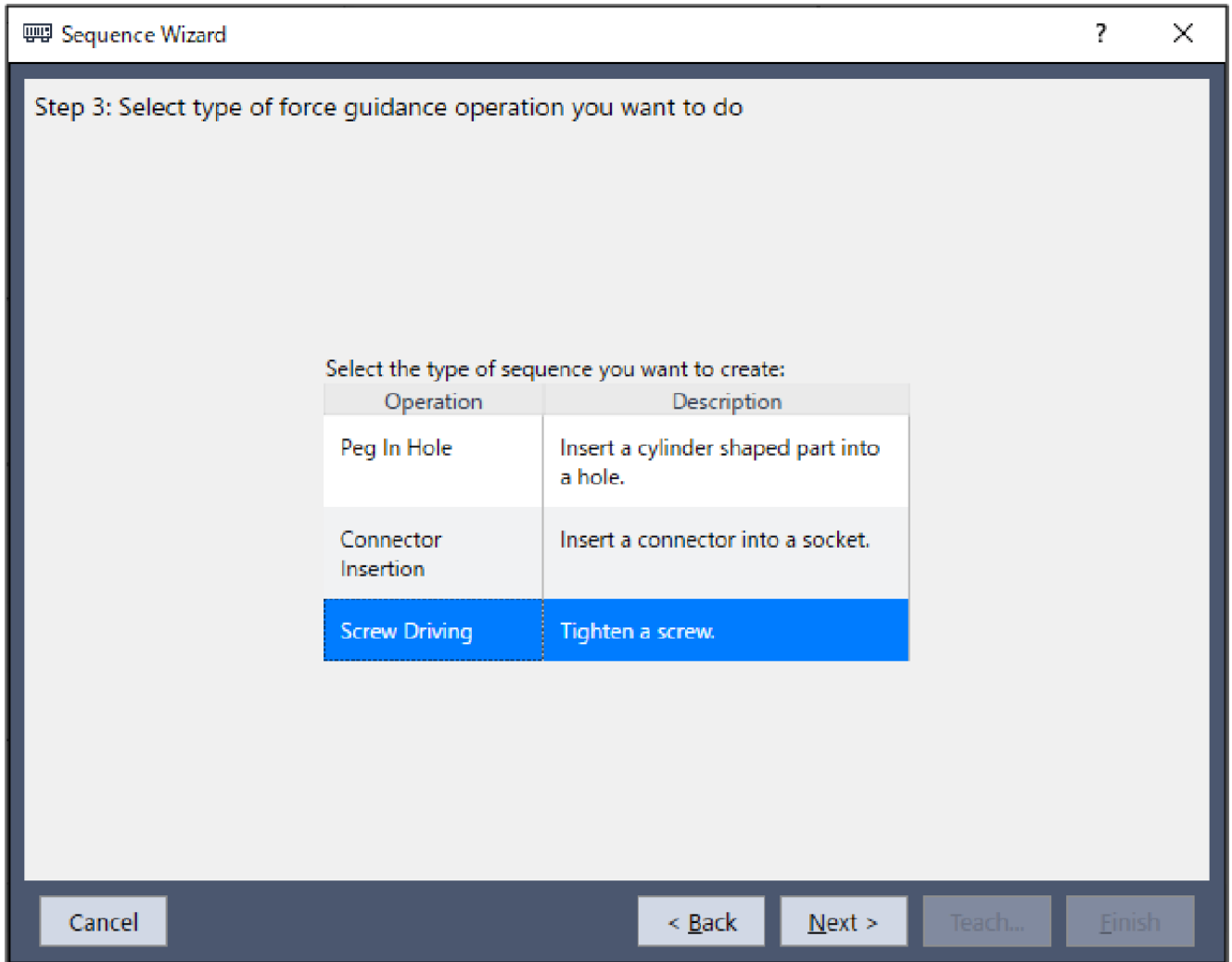

4. The [Step 3: Select the sequence template for the selected operation] dialog box is displayed. Select [Standard]. Click the [Finish] button.

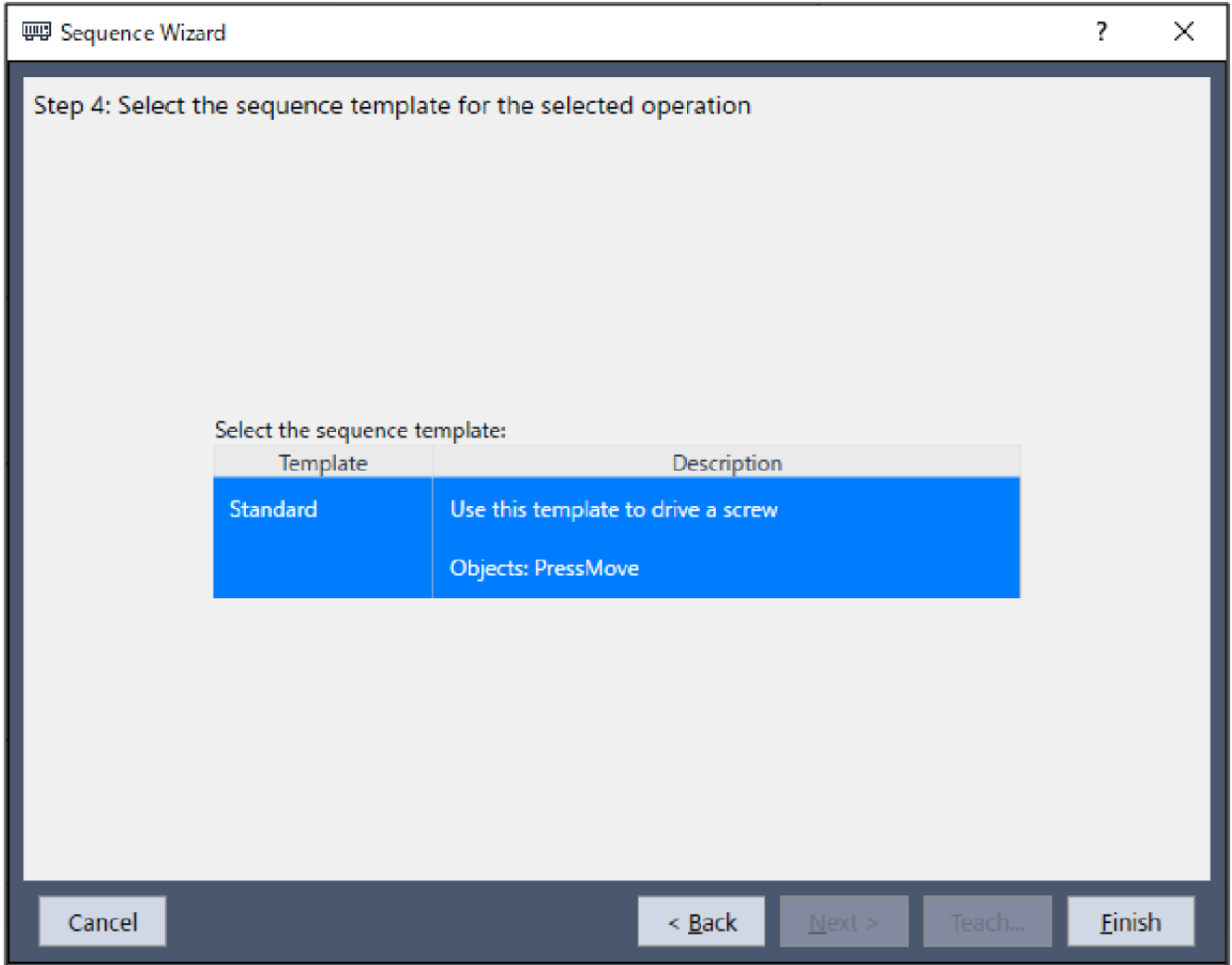

5. Confirm that the [ScrewUp] sequence is created.

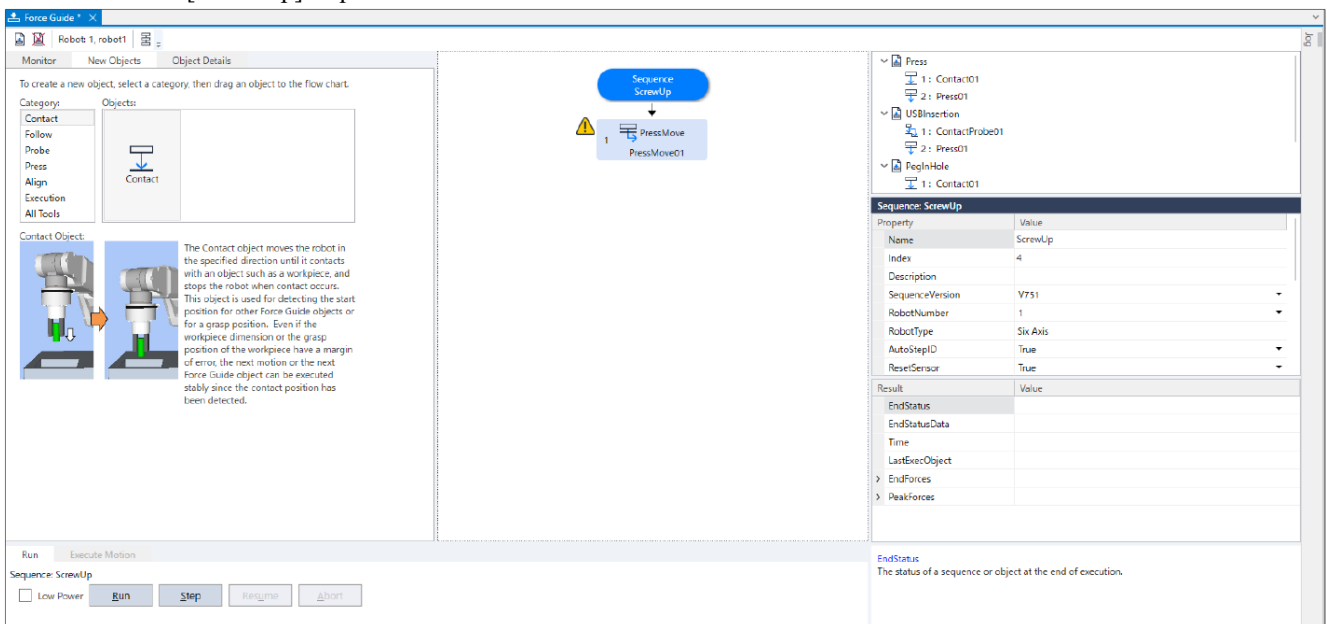

4.6.2.4.2 Confirmation of Tool Setting

The following describes tool setting procedures.

For "Screw Driving", you need to be careful of correspondence between the direction of actual screw driving and the current tool setting.

1. Use a caliper to measure the distance of X, Y, and Z from the J6 flange plane to the end of the electric screwdriver.
2. Execute the following in [Command Window]. Enter the values measured in procedure (1) in "LengthX, LengthY, LengthZ".

```
> Tlset 1,XY (LengthX, LengthY, LengthZ, 0, 0, 0)
```

3. Click Epson RC+ menu-[Tools]-[Simulator]. The [Simulator] window is displayed.
4. Select the object tree-[Manipulator Name]-[Tool].
5. Place a checkmark in "No.1"-[Visible] check box.

To confirm that the tool setting is correct, compare the display of the [Simulator] window and the orientation of the actual robot.

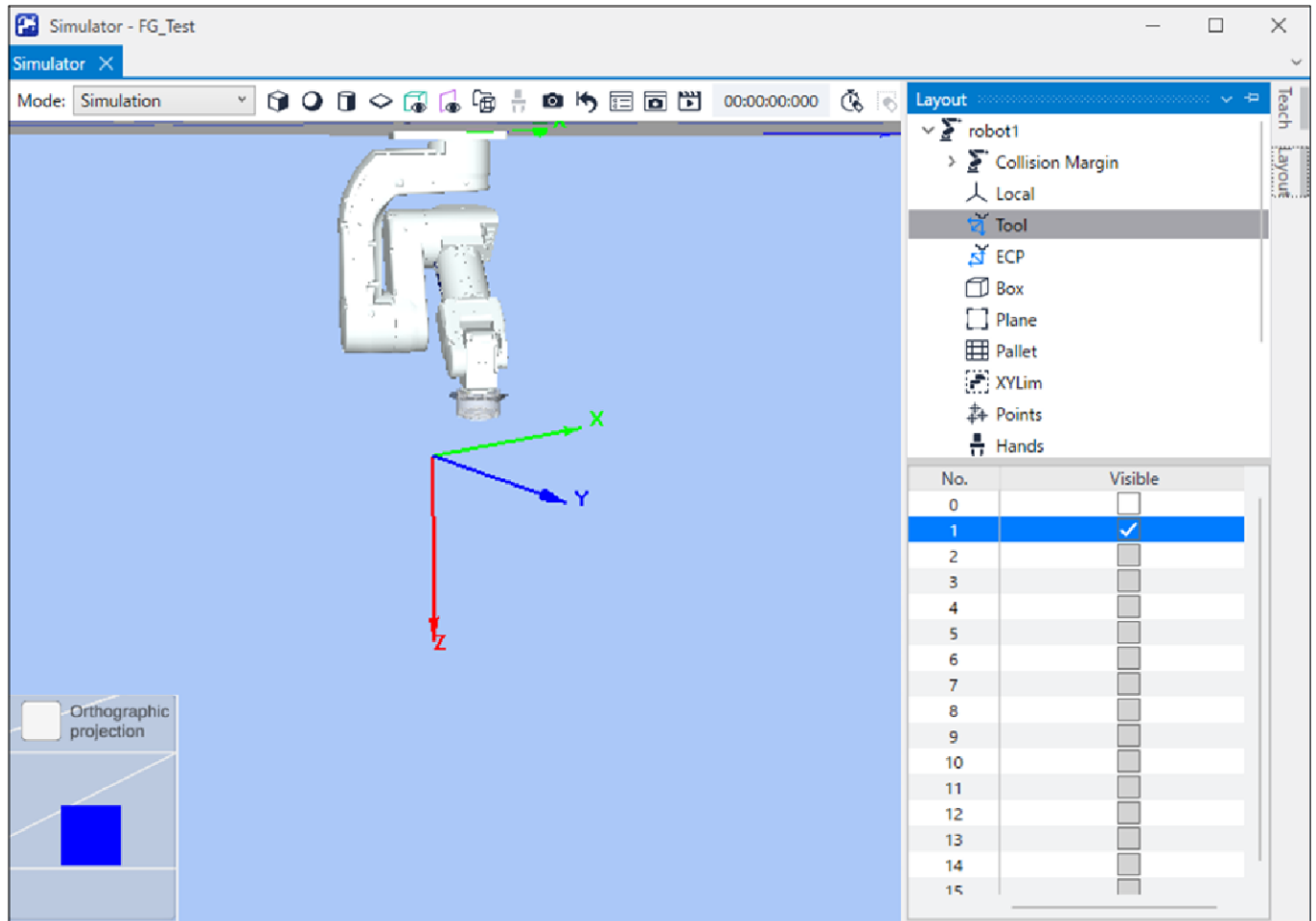

According to the display of the [Simulator] window, you will see that screw driving is performed to +Z direction of the tool.

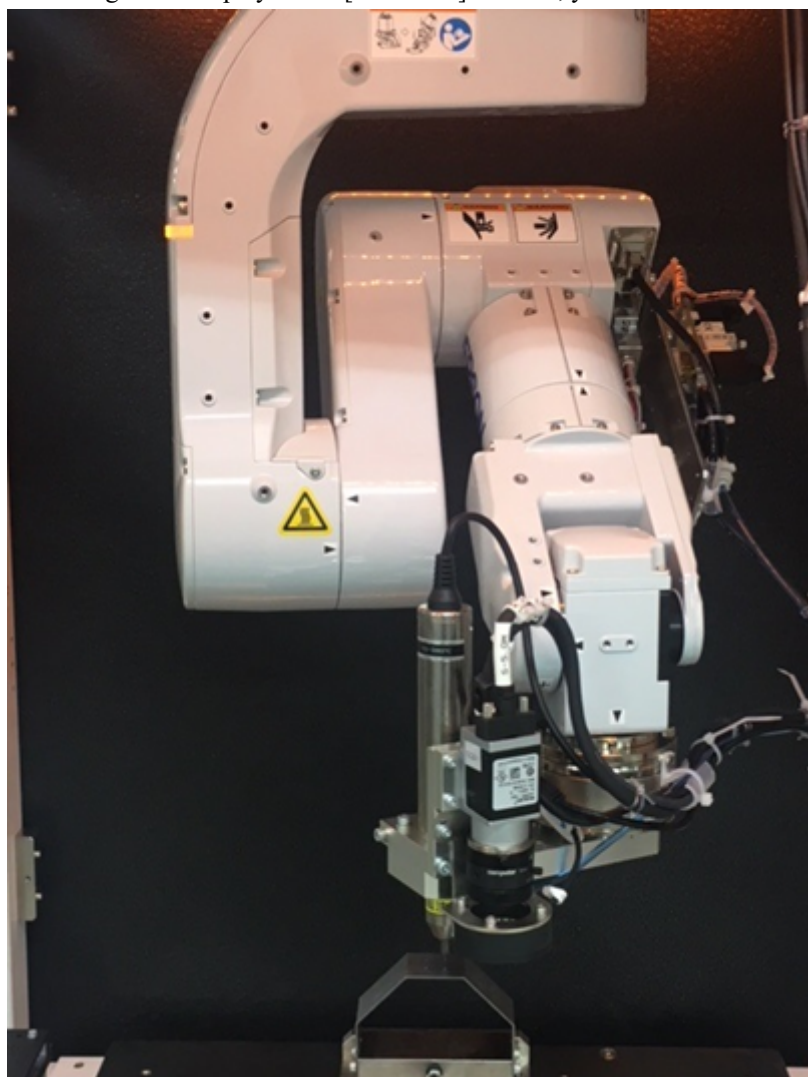

4.6.2.4.3 Position Teaching

The following describes how to teach a start position of "Screw Driving" motion.

1. Click Epson RC+ menu-[Tools]-[Robot Manager]. The [Robot Manager] dialog box appears.
2. Select [Jog & Teach] and open the panel.

3. Select "1" on [Tool].

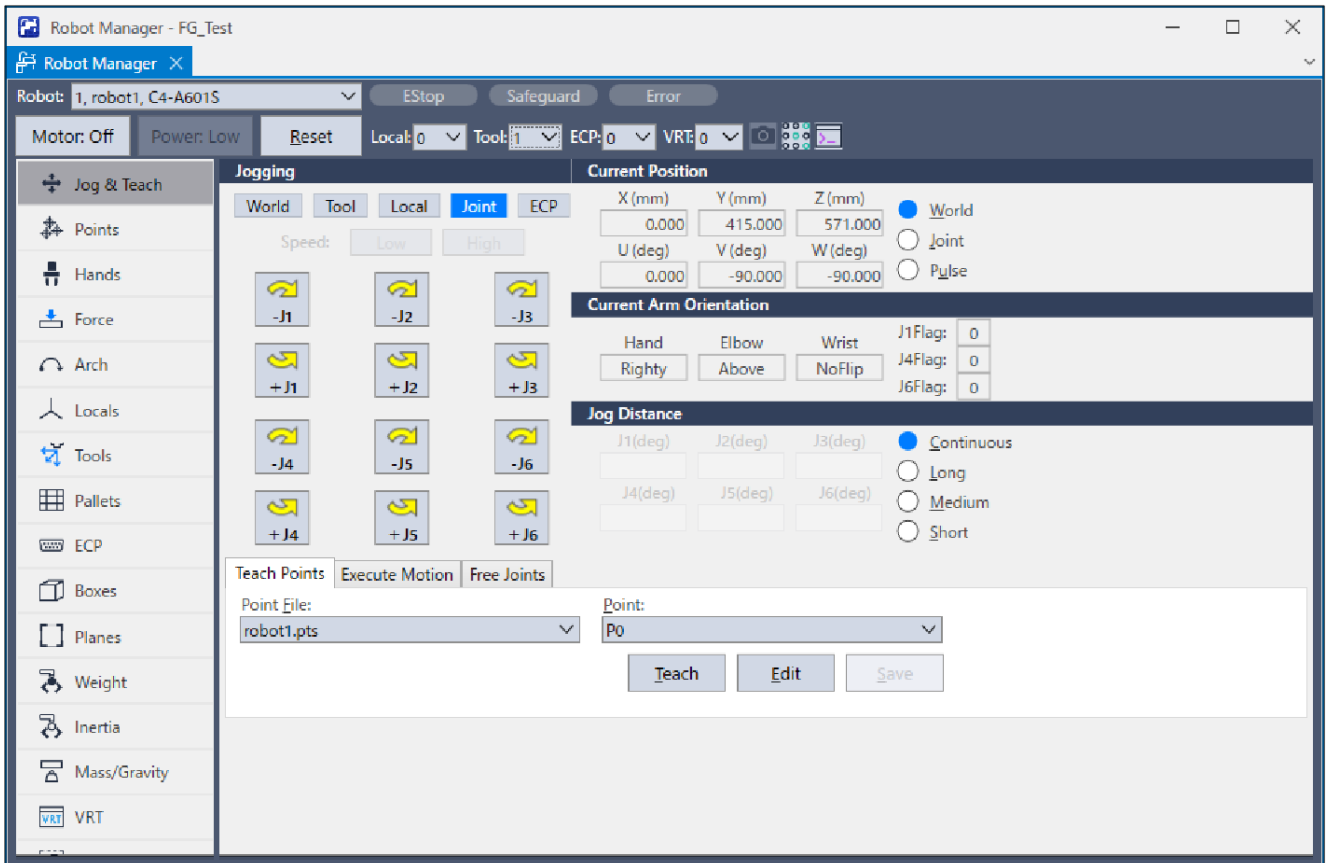

4. An electric screwdriver attaches to a screw.

5. Use the Jog button to move the robot to the following positions.

- X and Y directions : The end of the screw is within the taper part of the screw hole
- Z direction : The end of the screw is 1mm above the screw hole

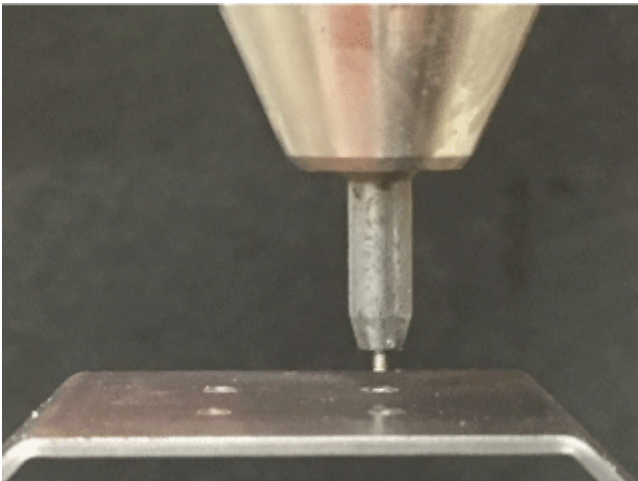

6. Select "P1" in the [Point] dropdown.

7. Click the [Teach] button. The following message is displayed. Confirm the message and click the [Yes] button.

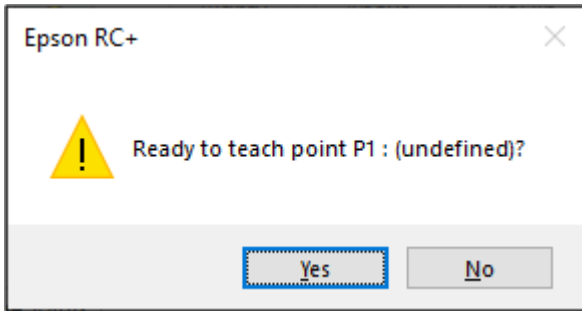

8. The [New Point Information] dialog box is displayed. Enter "Test_P1" on [Point label]. Click the [OK] button.

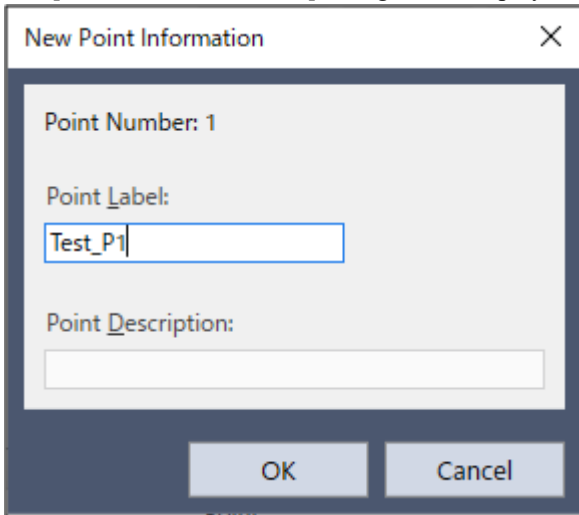



9. Click Epson RC+ menu-[File]-[Save All]. The file is saved.

4.6.2.4.4 Property Setting

The following describes how to set a property which is necessary for "Screw Driving".

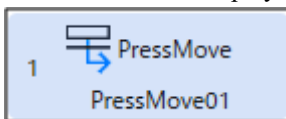
1. The  mark is displayed on the flow chart by default. You need to set properties.



Move the mouse pointer onto the  mark to display the tool tips. The tool tips show settings or content which need to be modified.

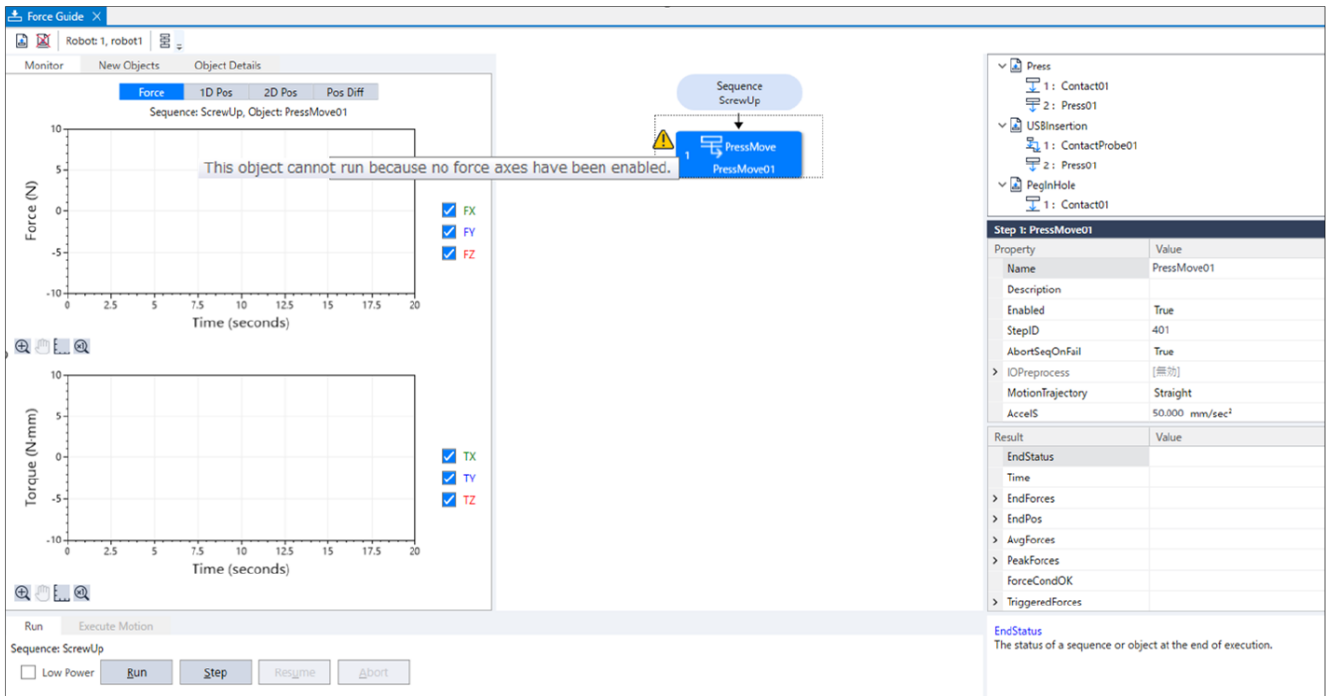

2. Select the sequence flow of [ScrewUp]. Properties and Results are displayed.

3. Select "1" on the [RobotTool] property. Tool 1 is set.

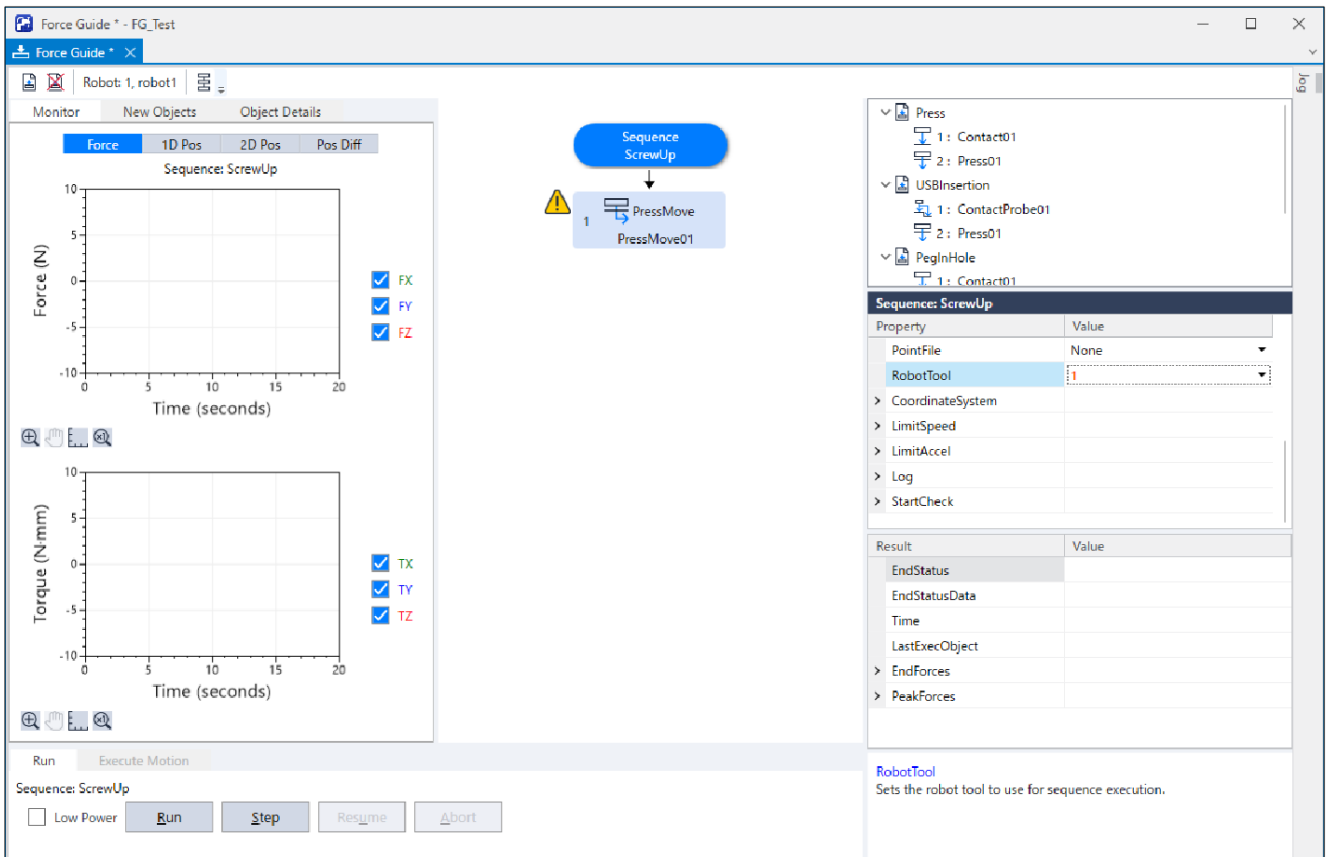



4. Select the [PressMove01] object. Properties and Results are displayed.

5. Click the [Fz]-[ControlMode] property and select "Press+".

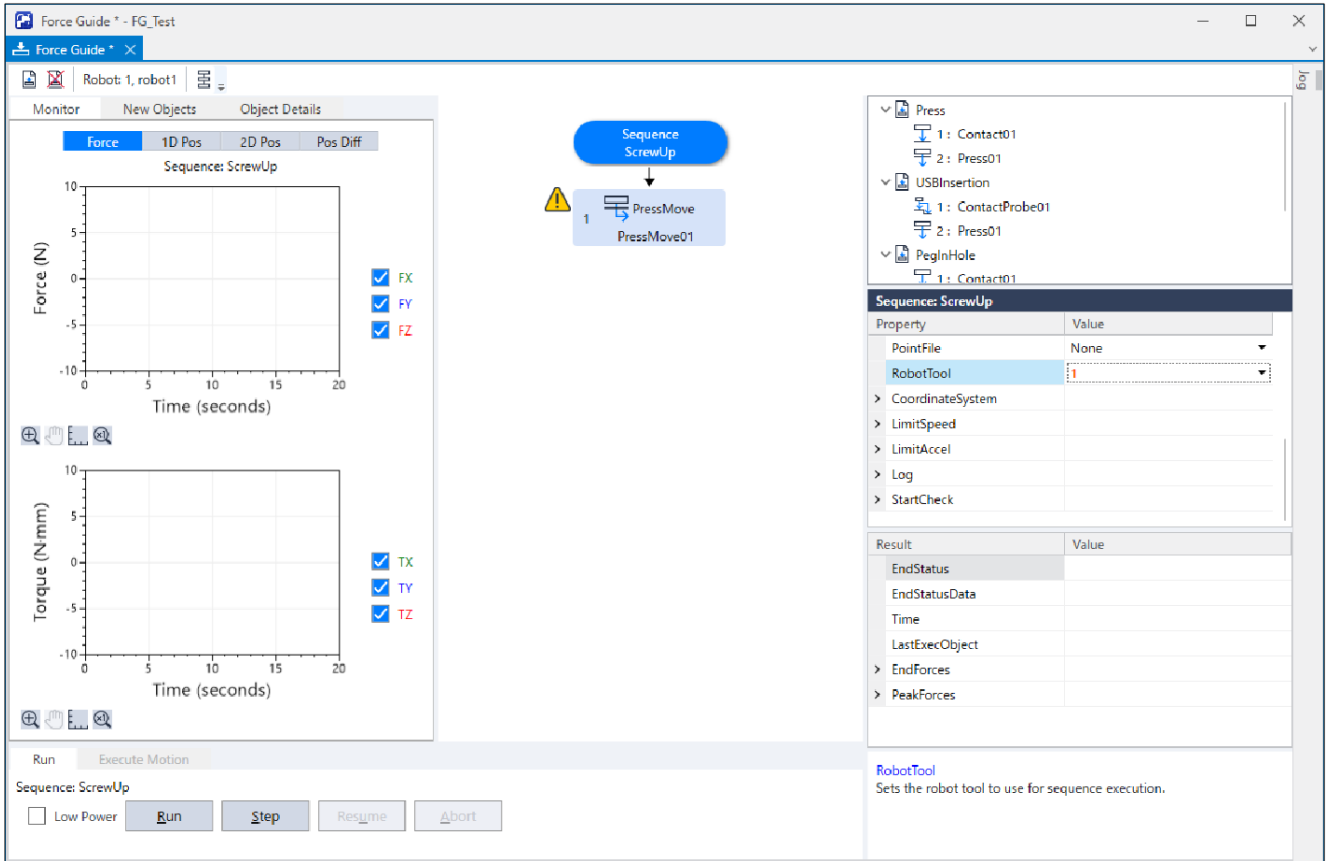
Pressing downward is set to 6-axis robot. At this time, only the negative value can be entered in [Force].

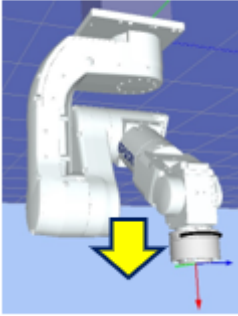

	6-axis robot	SCARA robot
Robot motion image Pressing		
(Press/Contact) Orient	+Fz	-Fz
Sign of Force (monitor display is included)	-	+

6. Change the following properties:

Item		Value	Description
I/O PreProcess	Enabled	True	Operate a specified Bit when an object starts.
	OutputBit	Electric screwdriver rotation output bit	Set the electric screwdriver to rotate when the object starts.
	OutputStatus	On	Enable a specified Bit when the object starts.
Destination	DestType	Relative	Set a destination point by relative distance from the start point.
	RelativeOrient	Tool	Set a destination point by relative distance on Tool coordinate system from the start point.
Fx	ControlMode	Follow	Follow by the force control function.
	Firmness	1	Set a firmness of the force control functions in X direction.
Fy	ControlMode	Follow	Follow by the force control function.
	Firmness	1	Set a firmness of the force control functions in Y direction.
Fz	ControlMode	Press+	Mode of force control function.
			Press+: The robot moves to a positive direction in Fz axis and presses.
	Force	-1	Set an applied force in Z direction
	Firmness	1	Set a firmness of the force control functions in Z direction.
I/O End Conditions	Enabled	True	Set the end conditions related to I/O.
	InputBit	Completion of screw driving	Set the object to end by a completion signal of screw driving.
		Input bit	
InputStatus	On	Make it an end condition that the input Bit is "On".	

7. To prevent the screw hole from being damaged, make sure to tighten screws with an appropriate speed for both the screws and the electric screwdriver. Calculate the following and set an appropriate speed.

SpeedS (mm/sec) = number of revolutions per second in an electric screwdriver (rps) × screw lead (mm)

AccelS (mm/2)=SpeedS × 10

If you set a distance for screw driving = screw length, tightening motion may stop in a middle of screw driving since the screw and its hole contact.

It is necessary to add a margin as follows:

$\text{DestRelativeZ(mm)} = \text{screw length (mm)} + 5(\text{mm})$

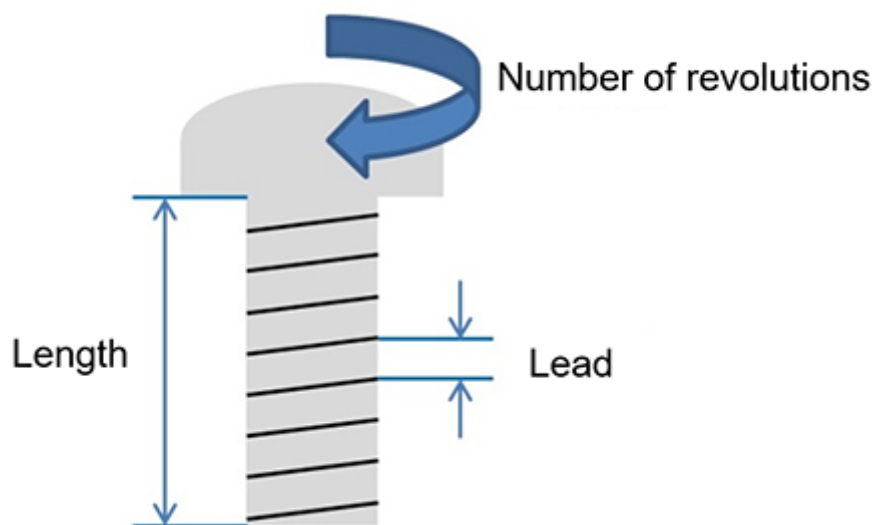

8. Click Epson RC+ menu-[File]-[Save All] to save the files.

4.6.2.4.5 Setting Confirmation

The following describes how to check whether the settings for the pressing direction are correct by using a simulator. Click Epson RC+ menu-[Tools]-[Simulator]. The [Simulator] window is displayed.

Click the object tree-[Tool]. Place a checkmark in the "No.1"-[Visible] check box. An arrow for "Tool 1" is displayed.
Click the object tree-[Force]-[Force Guide]-[ScrewUp]. Place a checkmark in the "PressMove01"-[Visible] check box.

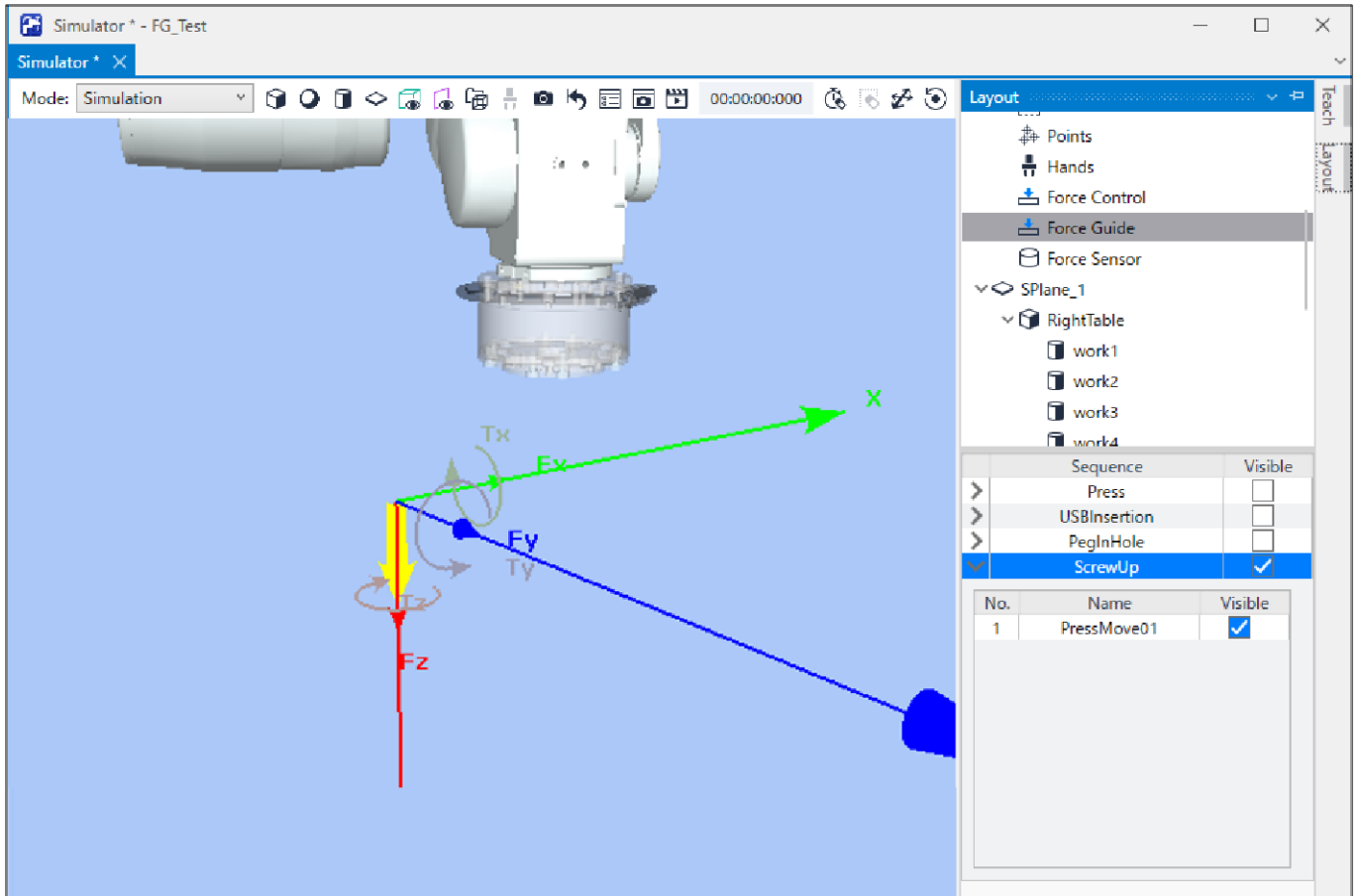

4.6.2.4.6 Motion by Force Guidance Function

The following describes how to execute a sequence that performs "Screw Driving" by Epson RC+.

Display the [Force Guide] window.

Select the [Jog] tab.

Click the [POWER HIGH] button. If the robot might break the workpiece, operate in "Low Power Mode".

Click the [Execute] button. Program is compiled and transmitted to the Robot Controller. If the setting is not correct, an error occurs. Check the settings so far and follow the error message to modify the parameters.

When the operation is performed properly, screw driving is completed.

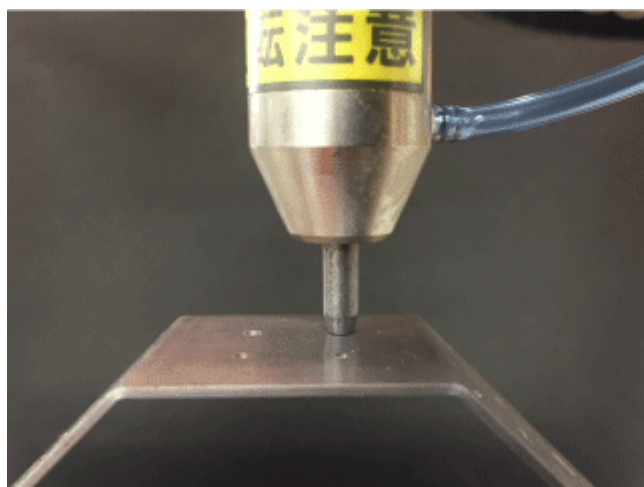
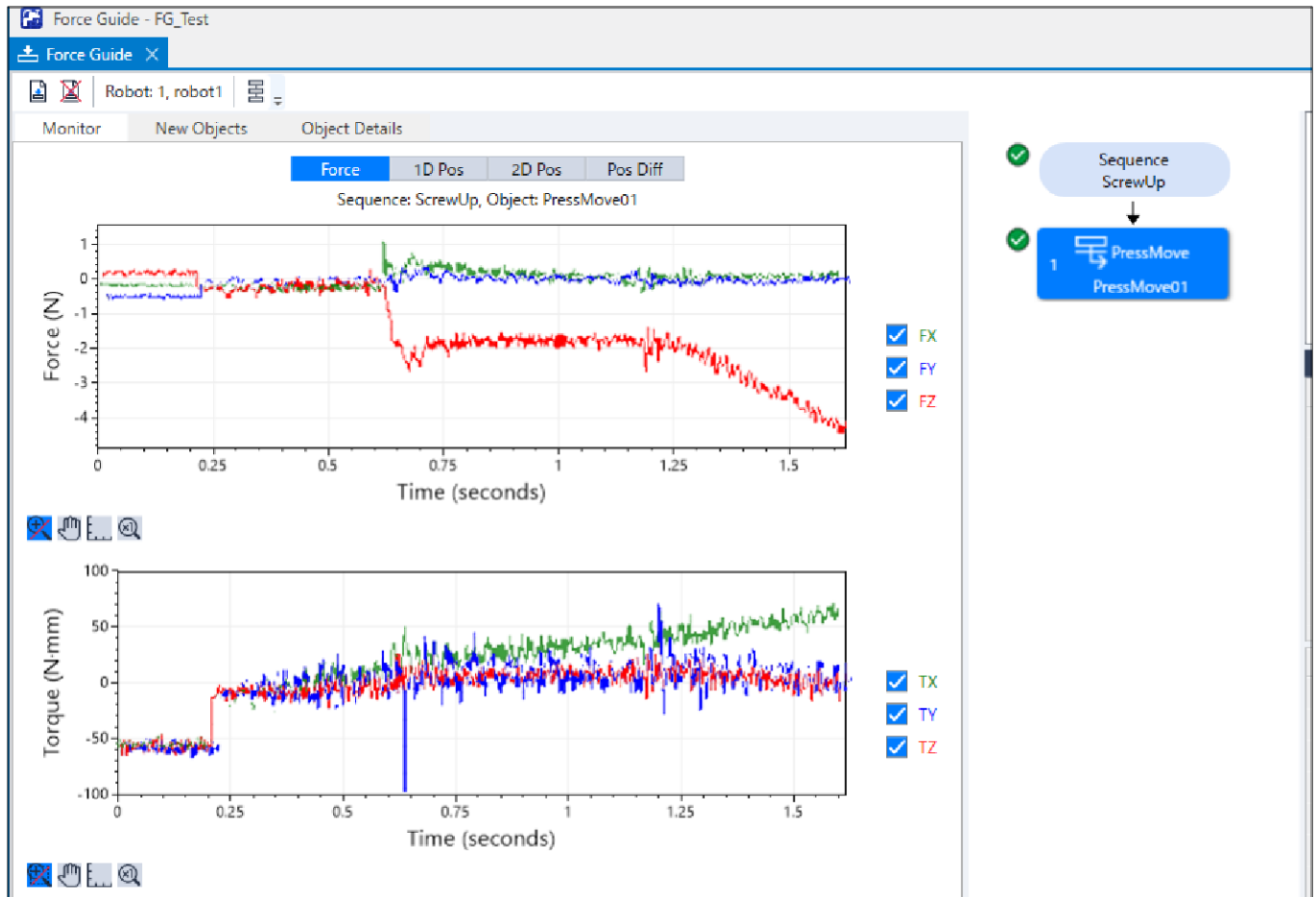

4.6.2.4.7 Return to the Non-Contact State

Force continues to be applied to between the robot and the workpiece even after "Screw Driving" is completed. To prevent the robot and the end effector from malfunction or damages, after the operation ends, make sure that no force is applied to the object. If it is obvious that no force is applied to the object, you can omit this step.

Steps to return to a non-contact state are as follows:

- Click Epson RC+ menu-[Tools]-[Robot Manager]-[Jog & Teach] panel-[Jog] group and perform jog motion manually to move the robot away from the object.
- Click Epson RC+ menu-[Tools]-[Robot Manager]-[Jog & Teach] panel-[Execute Motion] tab and move the robot away from the object.

- Execute Move command on [Command Window] and move the robot away from the object.
- Add SPELFunc object after Press object, and automatically move the robot away from the object at the end of the force guide sequence.

The following describes how to return to non-contact state by clicking [Robot Manager]-[Jog & Teach]-[Execute Motion] tab.

1. Display the [Robot Manager] dialog box.
2. Click the [Jog & Teach] tab.
3. Select the [Execute Motion] tab.
4. Select "Move" in [Command].
5. Select "P1" in [Destination].
6. Click the [Execute] button.

The robot moves to the start point: P1. Now, it is the non-contact state.

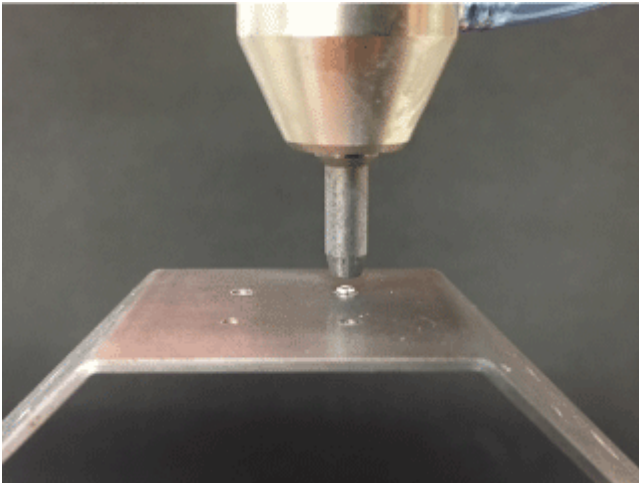

4.6.2.4.8 Motion Analysis by Monitor

The following describes how to use Epson RC+ to check the operation results of a force guide sequence.

1. Open the [Force Guide] window.
2. Click the sequence flow of [ScrewUp].

3. Select the [Monitor] tab.

Select the [Force] tab. Force and position during the [ScrewUp] sequence execution are displayed in the graph.

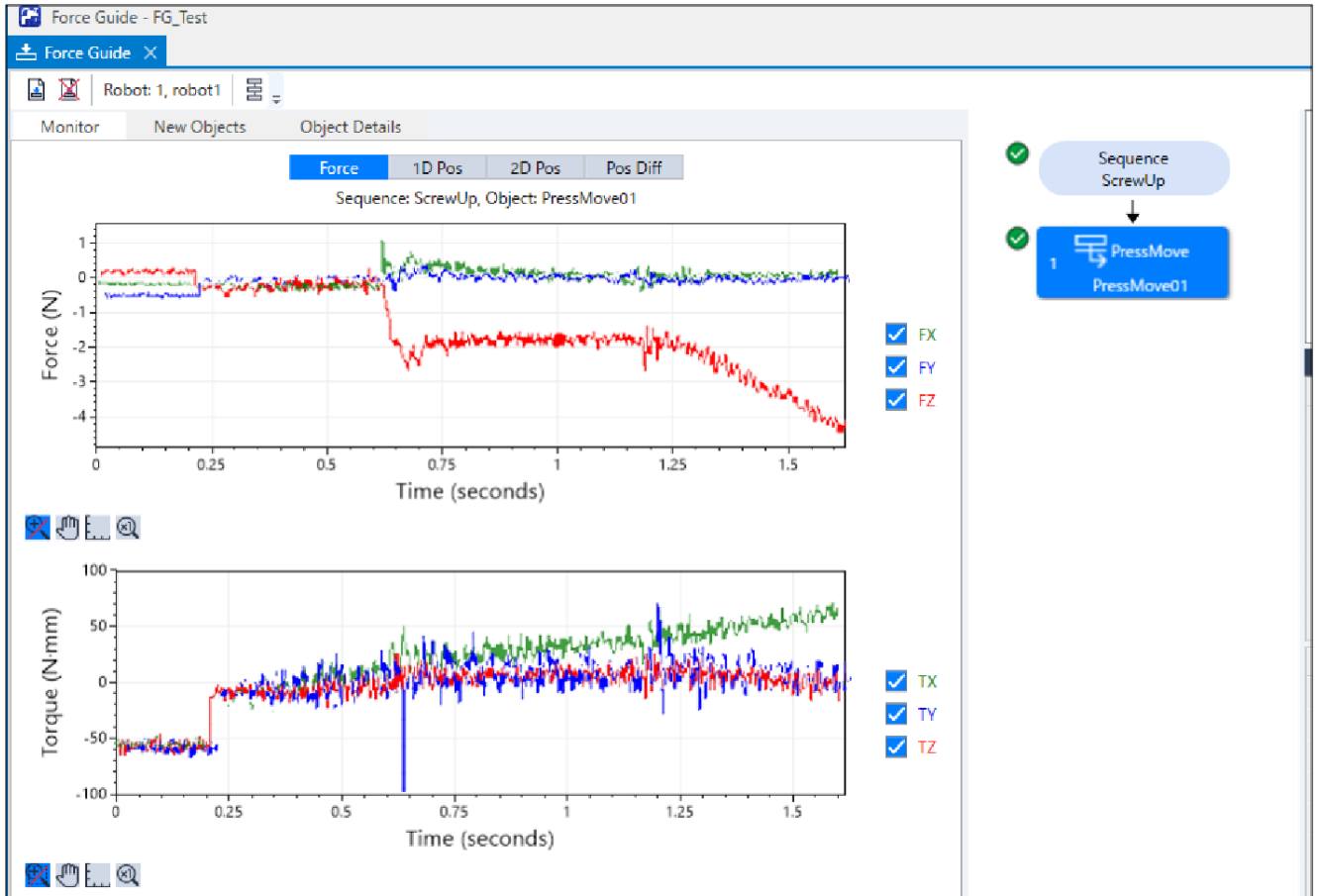

4. Select the [1D Pos] tab.

Graph for analysis is displayed. (horizontal axis: Time, vertical axis: Position)

As you can see by looking the Position Z graph, CurZ (current position) is lowered by about 3mm. As you can see by looking the Position Z graph, CurZ (current position) is lowered about 3mm.

Also, in the Position X and Position Y graphs, RefPos (reference position) is fixed, but CurPos moves up to approximately 0.1mm. It indicates that the robot follows the surface along with the screw insertion.

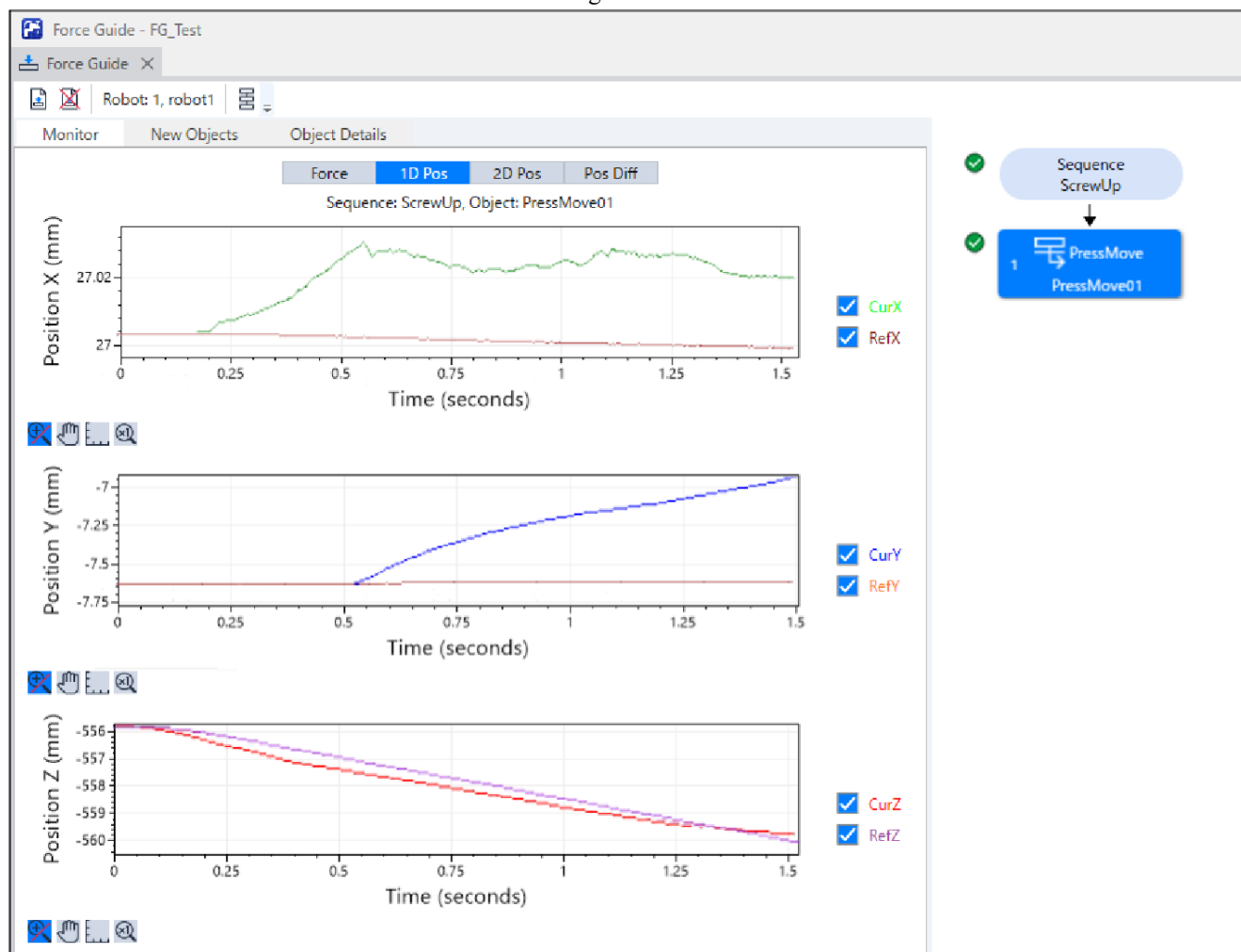

5. Select the [2D Pos] tab.

Graph for analysis is displayed. (horizontal axis, vertical axis: Position)

You can see what you have checked on the [1D Pos] tab as a graph projected on each plane. Be careful of the scale difference of horizontal axis and vertical axis when checking the graphs.

The screenshot displays the Force Guide software interface for a sequence named "Press". The interface includes a menu bar with "Force Guide" and "Robot: 1, robot1", and a toolbar with "Monitor", "New Objects", and "Object Details". The "Object Details" panel is active, showing three 2D position graphs: "XY plane from +Z axis view", "YZ plane from +X axis view", and "XZ plane from +Y axis view". Each graph plots position in millimeters (mm) on both axes, with a blue line for "Current Position" and a red line for "Reference Position". A legend indicates both are checked. To the right, a sequence diagram shows the steps: "Sequence Press", "1 Contact Contact01", and "2 Press Press01". The bottom panel shows "Run" and "Execute Motion" tabs, with a "Sequence: Press" section containing a "Low Power" checkbox and buttons for "Run", "Step", "Resume", and "Abort".

6. Select the [Pos Diff] tab.

Record shifts by force control as relative position changes. It is different from the graph on the [1D Pos] tab.

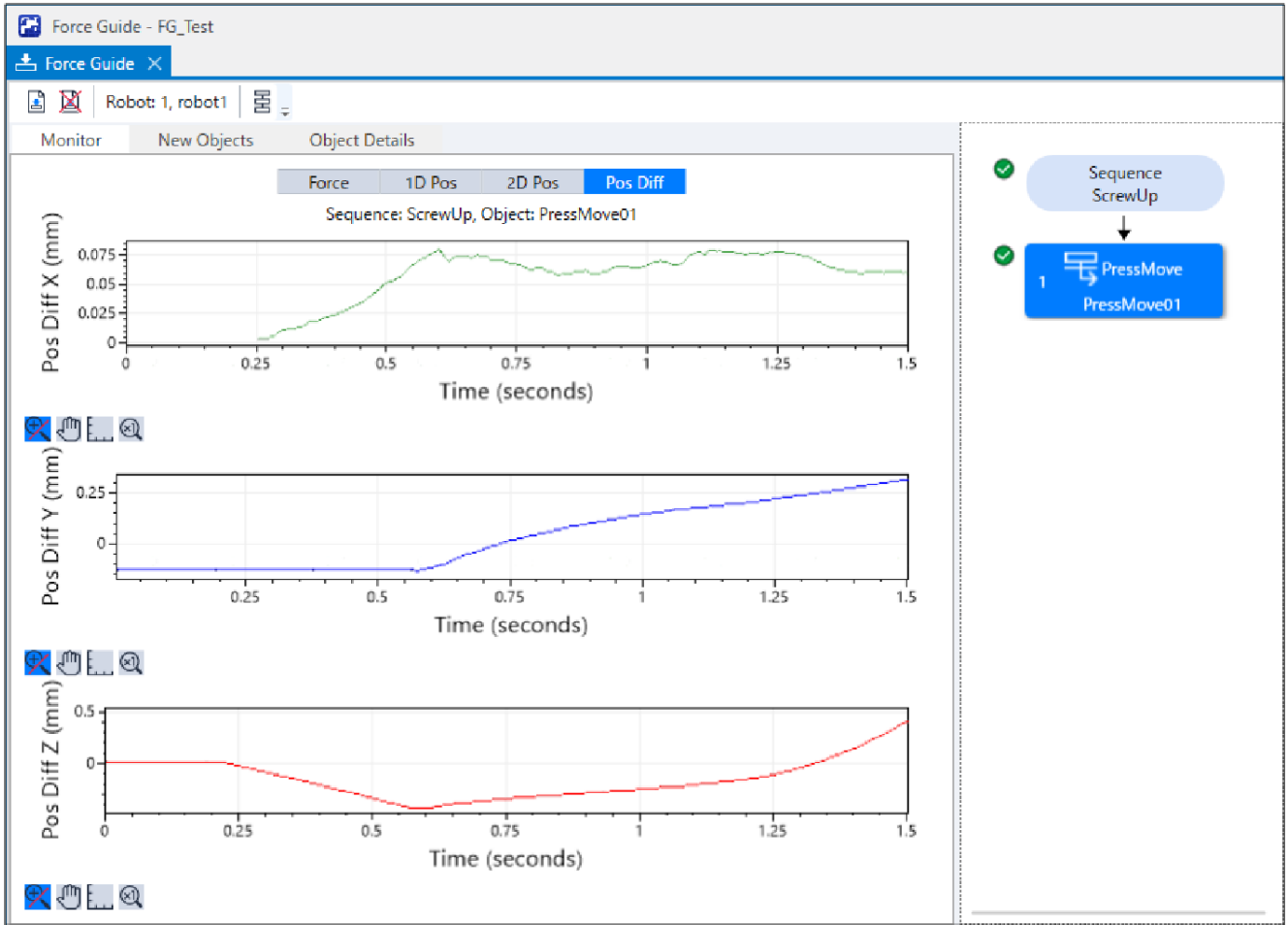

7. Change the unit of the graph and check the changes of force or positions.

If it is not inserted correctly, setting may not be correct. Refer to the following and check the procedures of the tutorial.

- Whether a pressing force direction is correct
- Whether the start point is largely moved from a hole
- Whether settings of AccelS, SpeedS are correct
- Whether a setting value of DestRelativeZ is short

Now, tutorial for screw driving is completed.

4.6.3 Tutorial Using System Force Guide Sequence

4.6.3.1 Paste Sequence

The following describes how to perform a paste operation using Paste sequence of the system force guide sequences.

Prepare a workpiece by yourself. Incorrect settings may result in damage of the workpieces. Prepare workpieces that can be damaged, and proceed with this tutorial.

Set the arrangement and pasting direction of a workpiece in the same way as the image below.

The specification of the workpiece gripped in the image is as follow.

Pasting surface (prism): 30 mm × 30 mm



CAUTION

The parameters described in the example on the following pages are reference values.

This tutorial uses relatively stable parameters, but depending on the operating environment, the operation may not be successful or the motion may be vibratory. Note that adjusting the parameters may be required. note that

Slow, stable parameters are used for convenience of explanation. For high-speed operation, adjusting the parameters is required.

4.6.3.1.1 Confirmation of Tool Setting

The following describes tool setting procedures.

In the Paste sequence, you need to consider the behavior of the actual pasting direction and the current tool settings.

1. Use a metal scale to measure the distance from the J6 flange plane to the pasting surface.

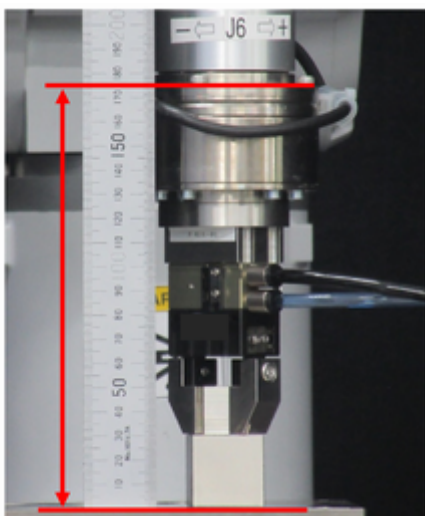

2. Execute the following in [Command Window].

In "Length", enter the value measured in the procedure (1).

```
> T1set 1,XY(0,0,Length,0,0,0)
```

3. Click Epson RC+ menu-[Tools]-[Simulator].
The [Simulator] window is displayed.
4. Select the object tree-[Manipulator Name]-[Tool].
5. Place a checkmark in "No.1"-[Visible] check box.
6. To confirm that the tool setting is correct, compare the display of the [Simulator] window and the orientation of the actual robot.

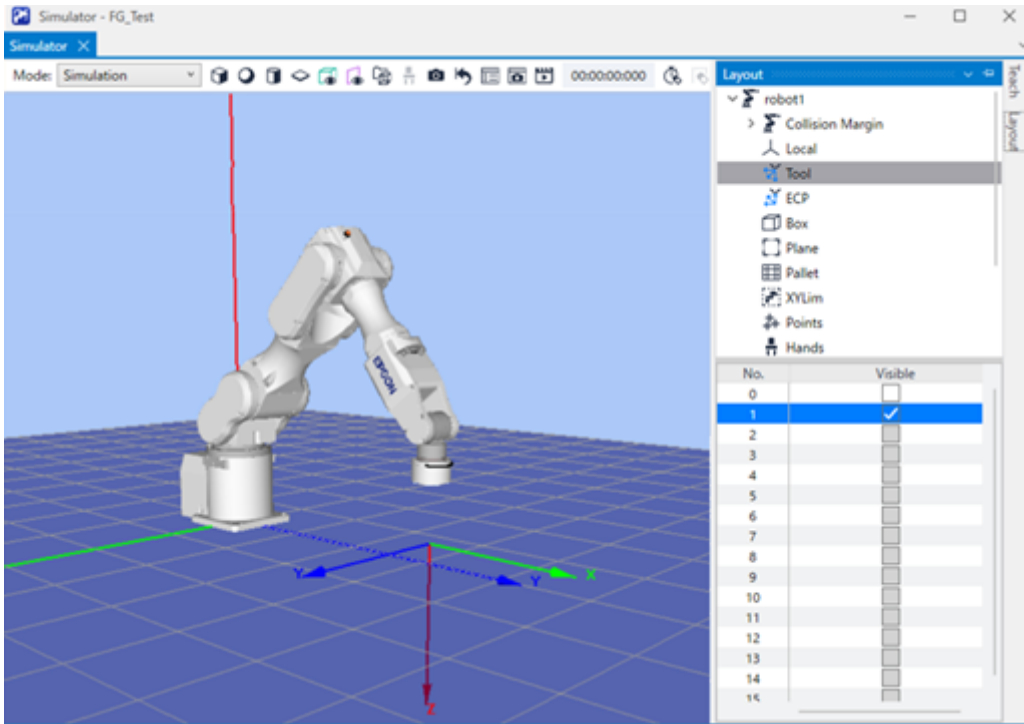

7. According to the display of the [Simulator] window, you will see that pasting is performed to the +Z direction of the tool.



4.6.3.1.2 Position Teaching

The following describes how to teach a sequence start position of Paste sequence.

1. Click Epson RC+ menu-[Tools]-[Robot Manager]. The [Robot Manager] dialog box appears.

- 2. Select [Jog & Teach] and open the panel.
- 3. Select "1" on [Tool].

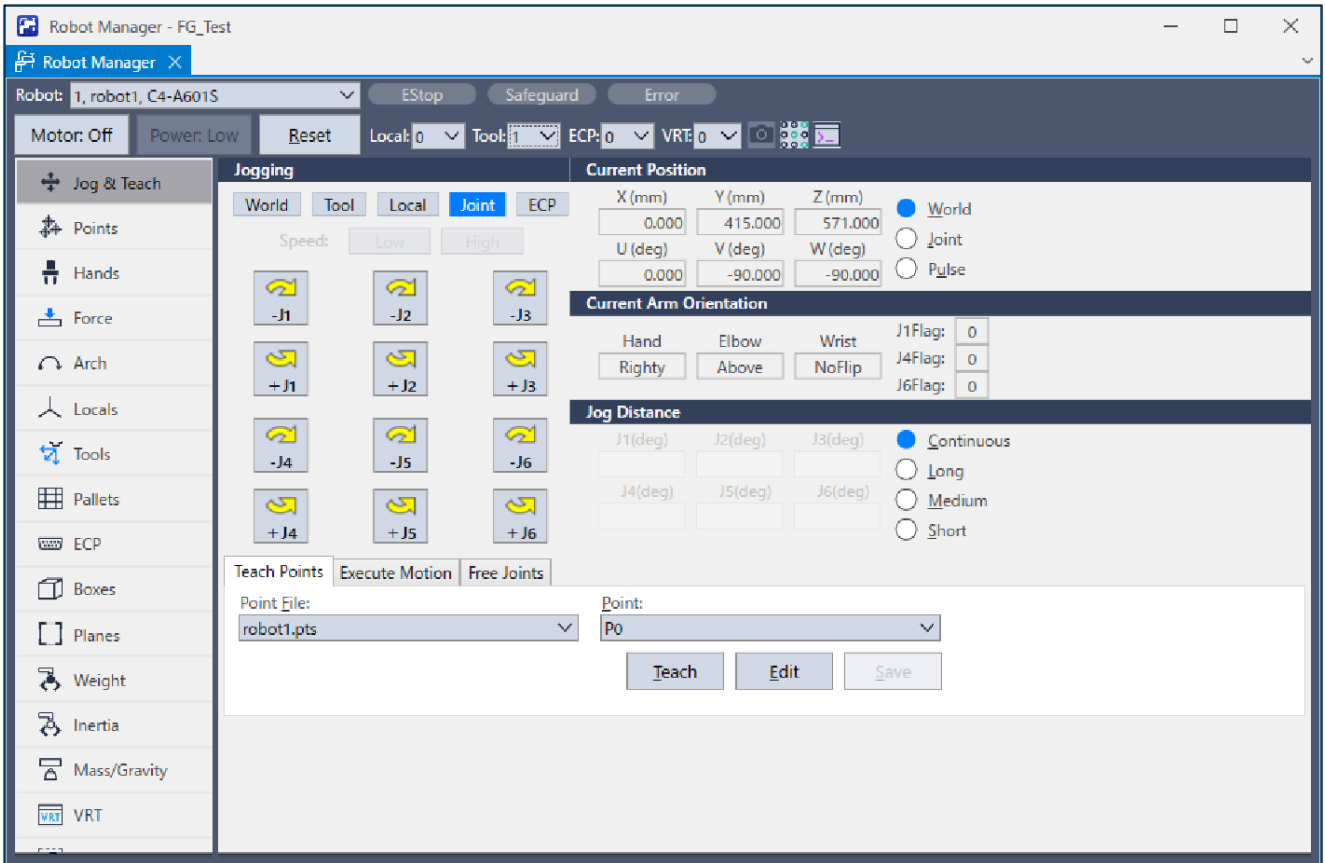

- 4. Use the Jog button to move the robot about 2mm above the pasting position. Execute the following command in the command window if necessary.

```
> Go Align (Here)
```

By executing the above command, the robot will be a parallel orientation against the Base coordinate system based on the current position. The robot can move with the robot and the point facing each other.

For details, refer to the following manual:
"Epson RC+ SPEL+ Language Reference" Align Function

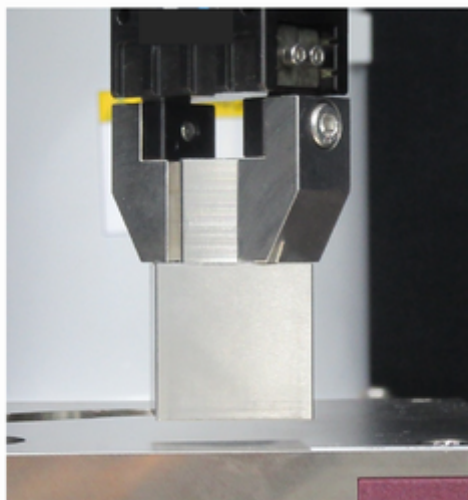

- Select Epson RC+ menu-[Tools]-[Force Monitor].
The [Force Monitor] dialog box is displayed.

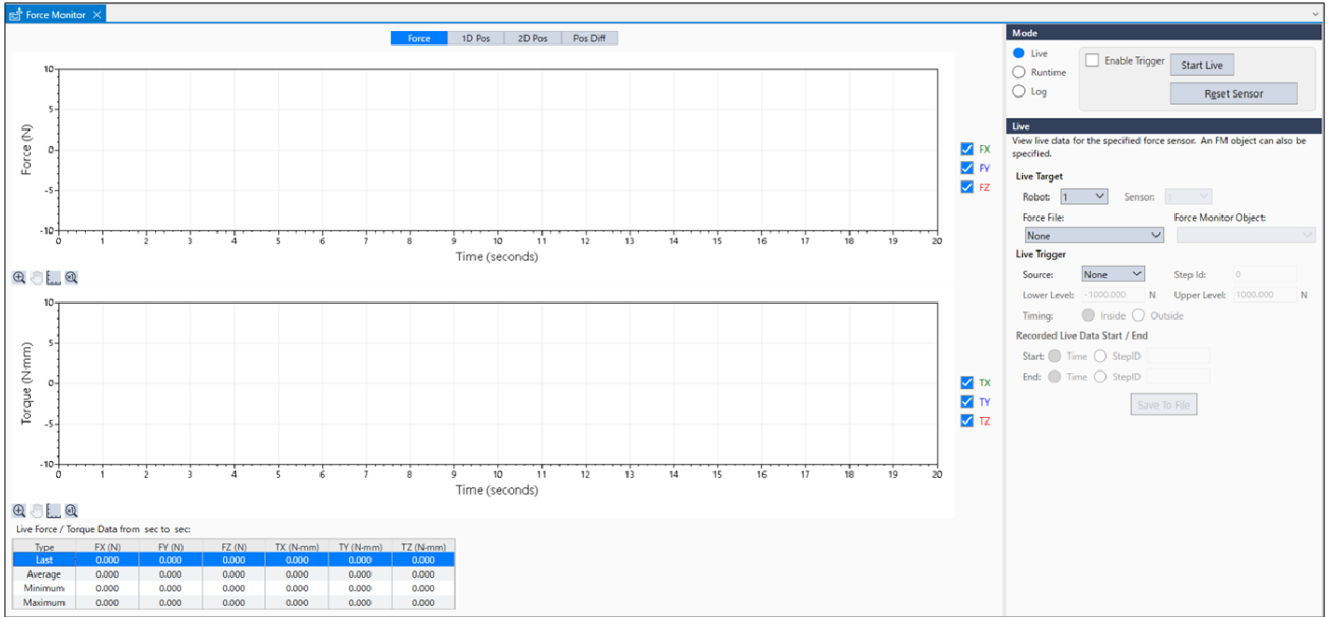

- Select [Short] button on [Jog Distance].
Click the Jog button several times to move the robot to -Z direction until the pasting surface contacts with the workpiece to be pasted. When the robot contacts with the object, output value of Force Sensor changes. Check the changes of monitor value by the timing of the jog motion.

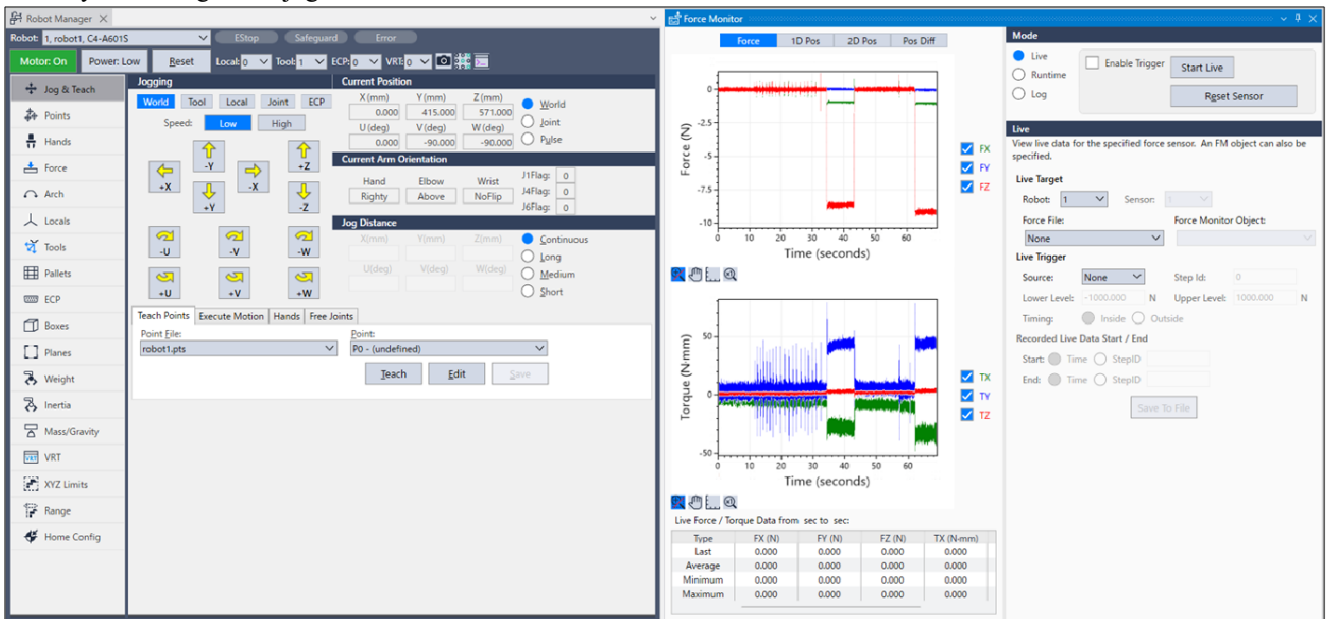

- Select the [Medium] button on [Jog Distance].
Click the Jog button five times and move the robot 5mm to +Z direction to put the workpiece in a non-contact state.

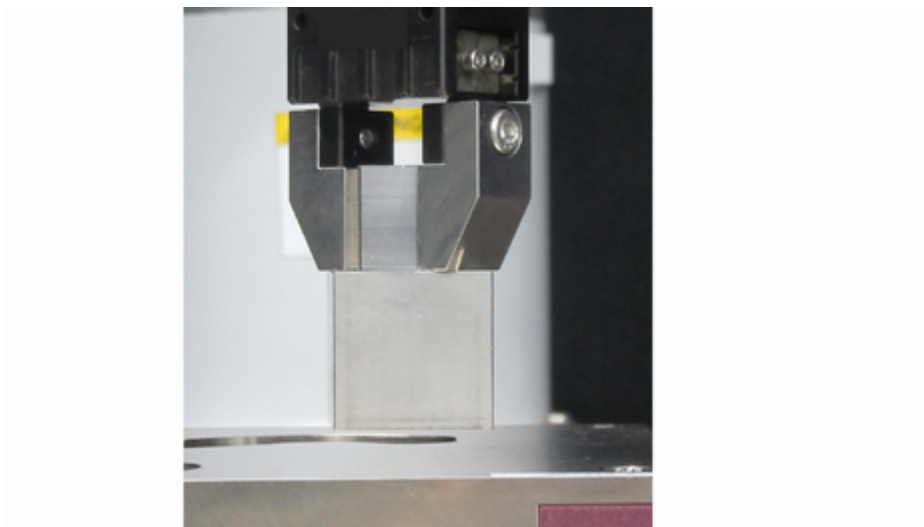

This is a start position of sequence and a position where the Force Sensor is reset.

8. Select "P1" in the [Point] dropdown.
9. Enter "PasteStart" in [Point Label]. Click the [OK] button.
10. Click Epson RC+ menu-[File]-[Save All].
The file is saved.

4.6.3.1.3 Sequence wizard

The following describes how to create a Paste sequence of the system force guide sequences.

1. Enter "PasteSeq" in the [Enter name for new sequence] box.

Click the [Next] button.

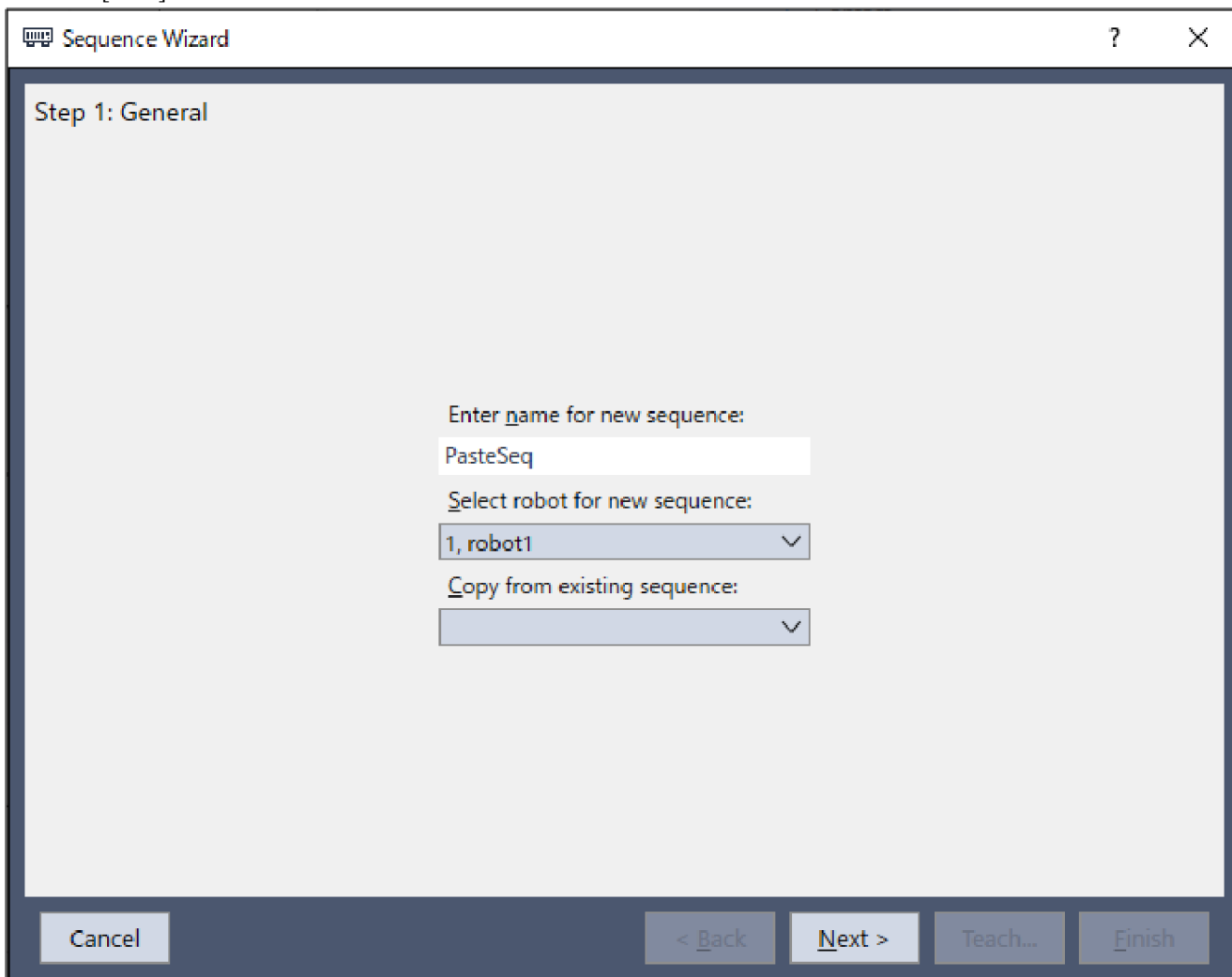

2. The [Step 2: Select sequence type] dialog box is displayed. Select [System]. Click the [Next] button.

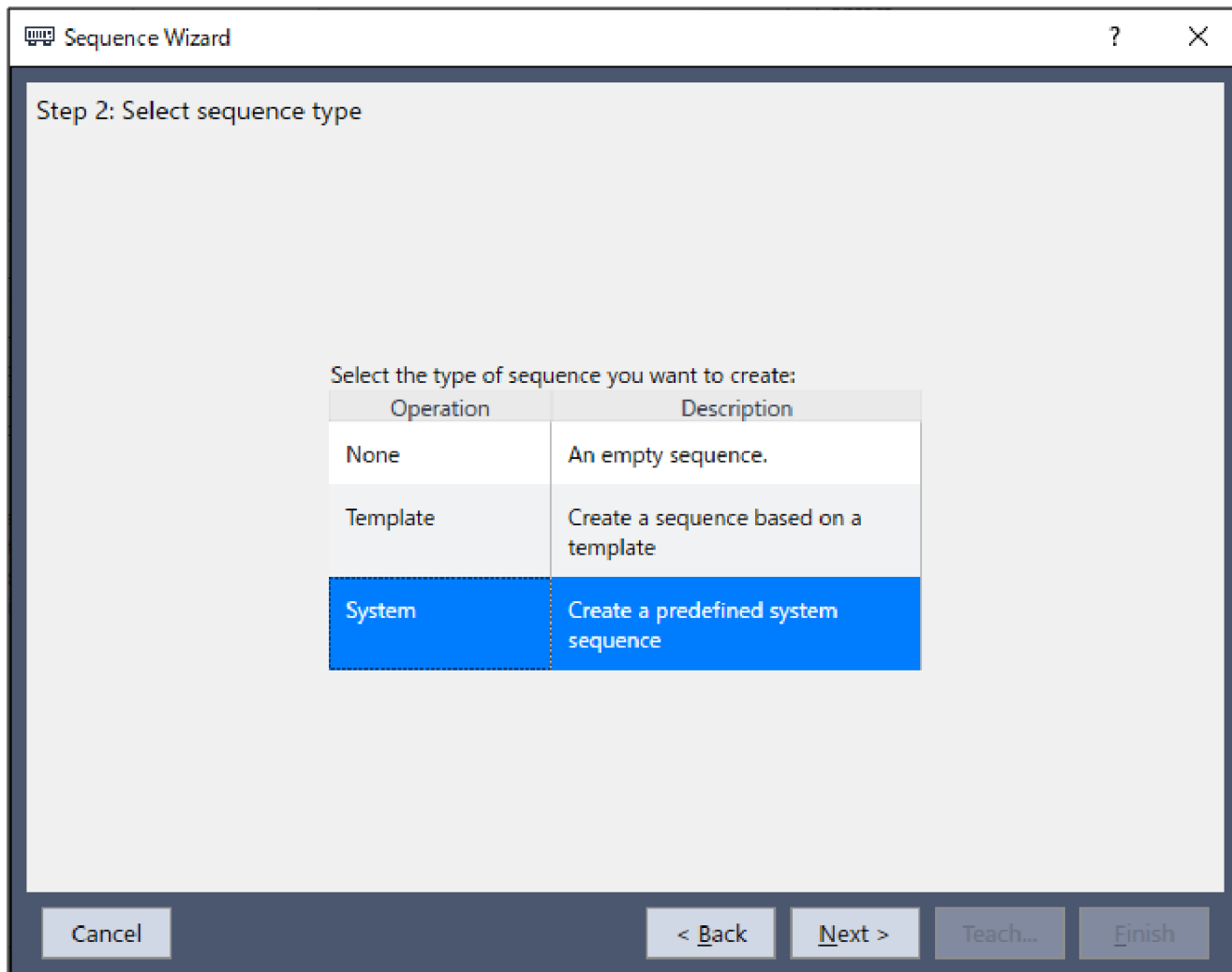

3. The [Step 3: Select system sequence] dialog box is displayed. Select [Paste]. Click the [Next] button.

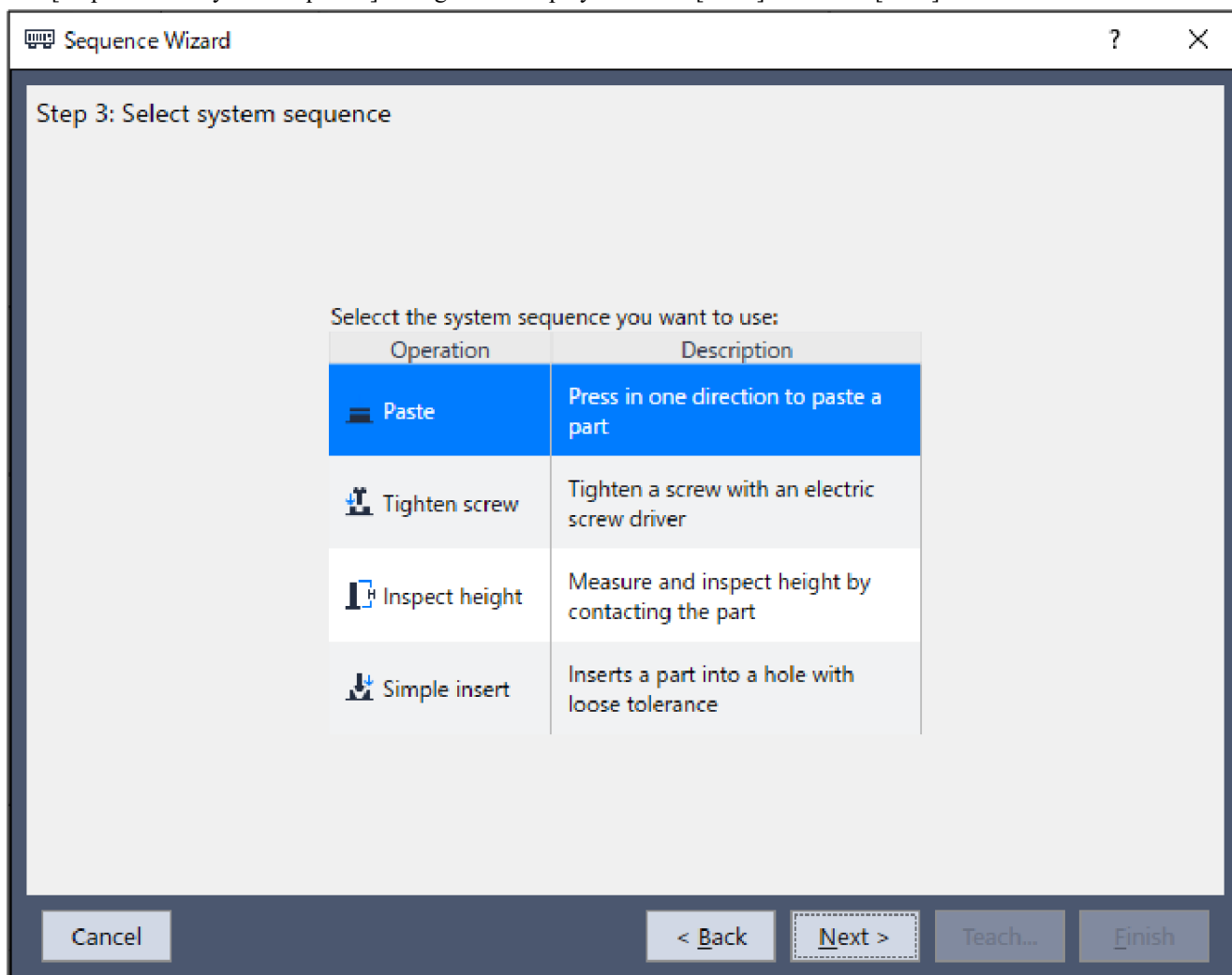

4. The [Step 4: Select the robot tool to use for the end effector] dialog box is displayed. Change the properties according to the table below. Click the [Next] button.

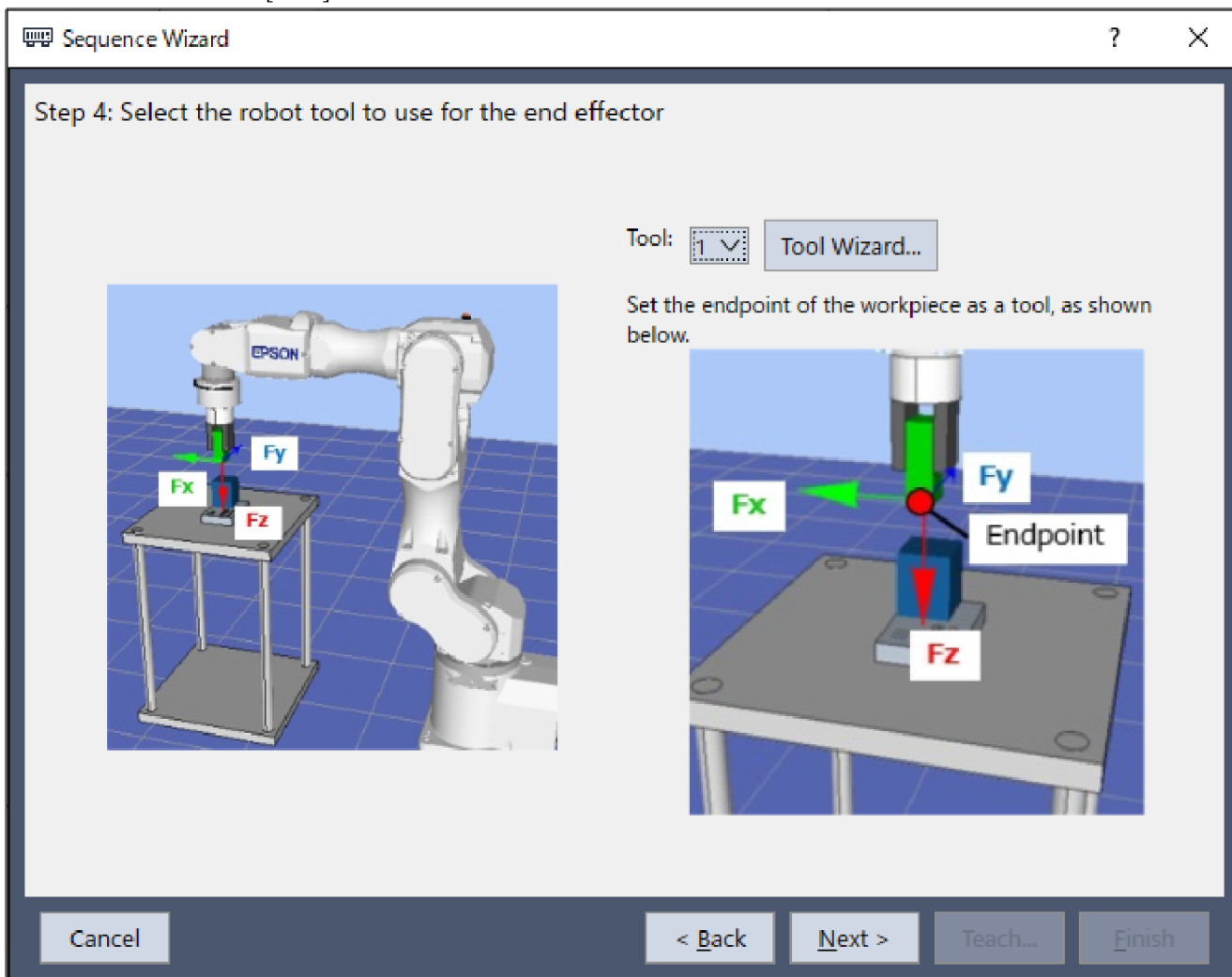

Item	Value	Description
Tool	1	Specify the number set for the tool used in this sequence.

5. The [Step 5: Set tool offsets] dialog box is displayed.

Set tool offset values. These values can be left as the default values and do not need to be changed.

Click the [Next] button.

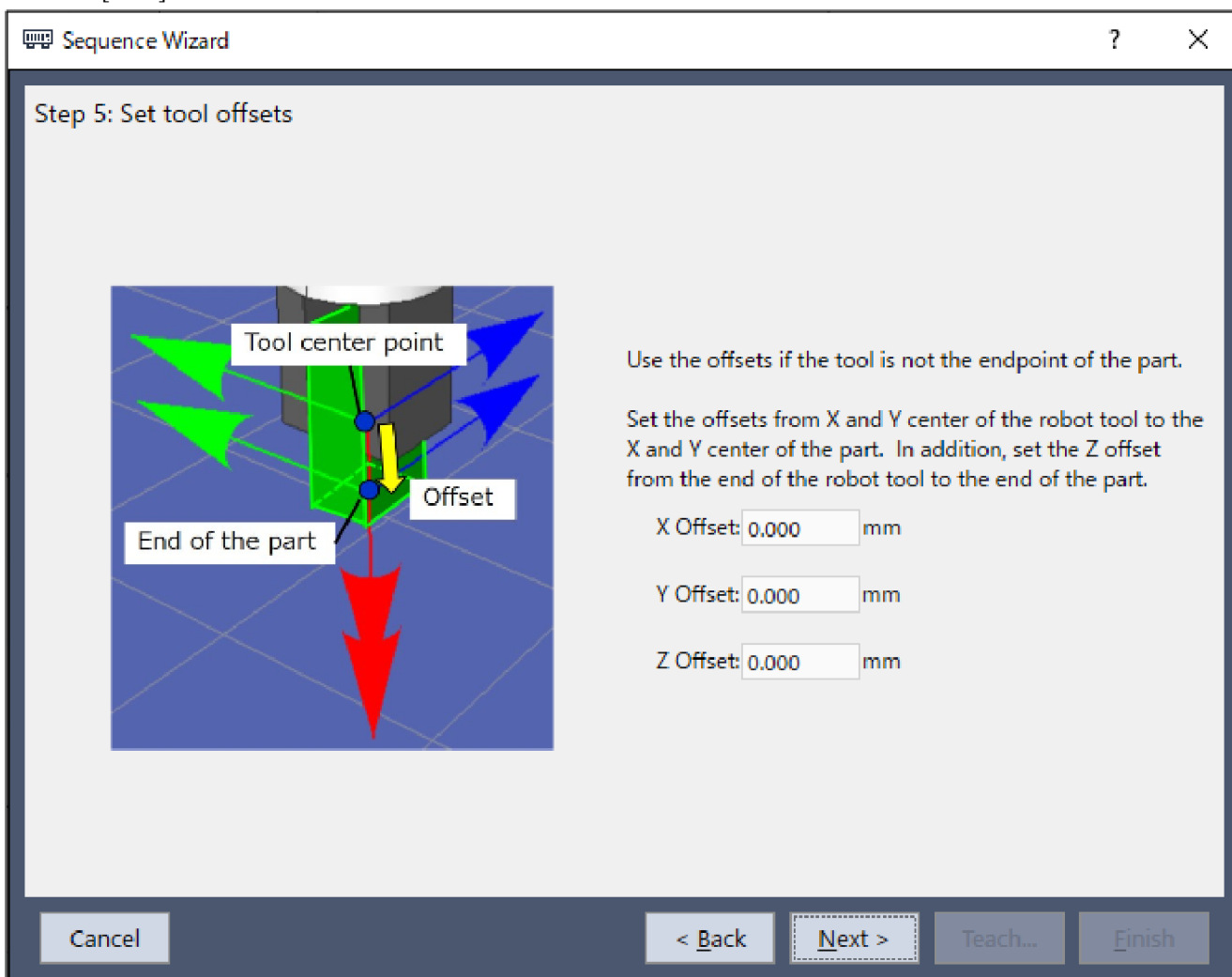

6. The [Step 6: Paste coordinate system and direction] dialog box is displayed.

As the pasting direction is in the +Fz direction in the tool coordinate system, these values can be left as the default values

and do not need to be changed.

Click the [Next] button.

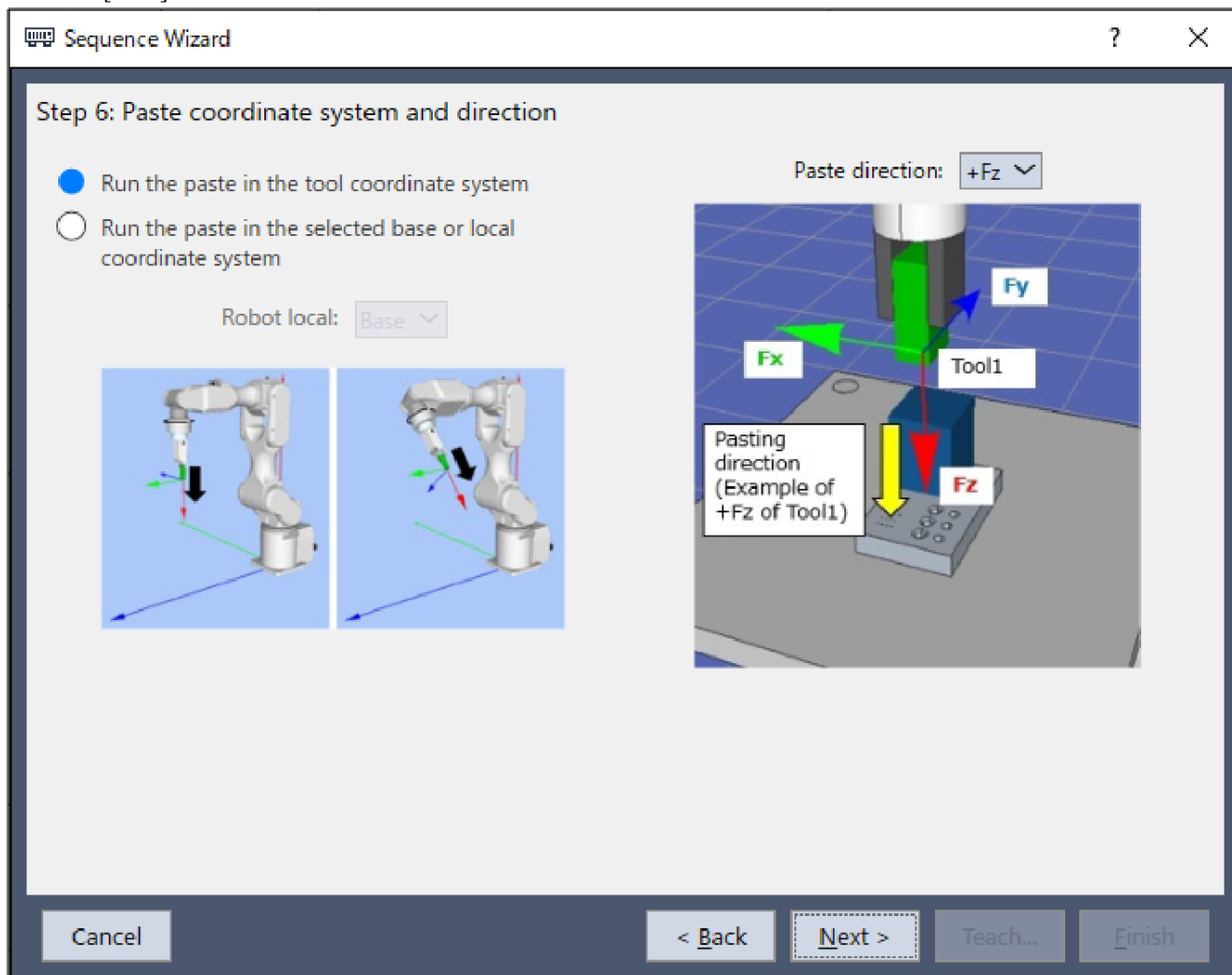

7. The [Step 7: Set whether paste surface alignment should be performed] dialog box is displayed.
Set whether to enable surface alignment.

As surface alignment is performed, this value can be left as the default value and does not need to be changed. Click the [Next] button.

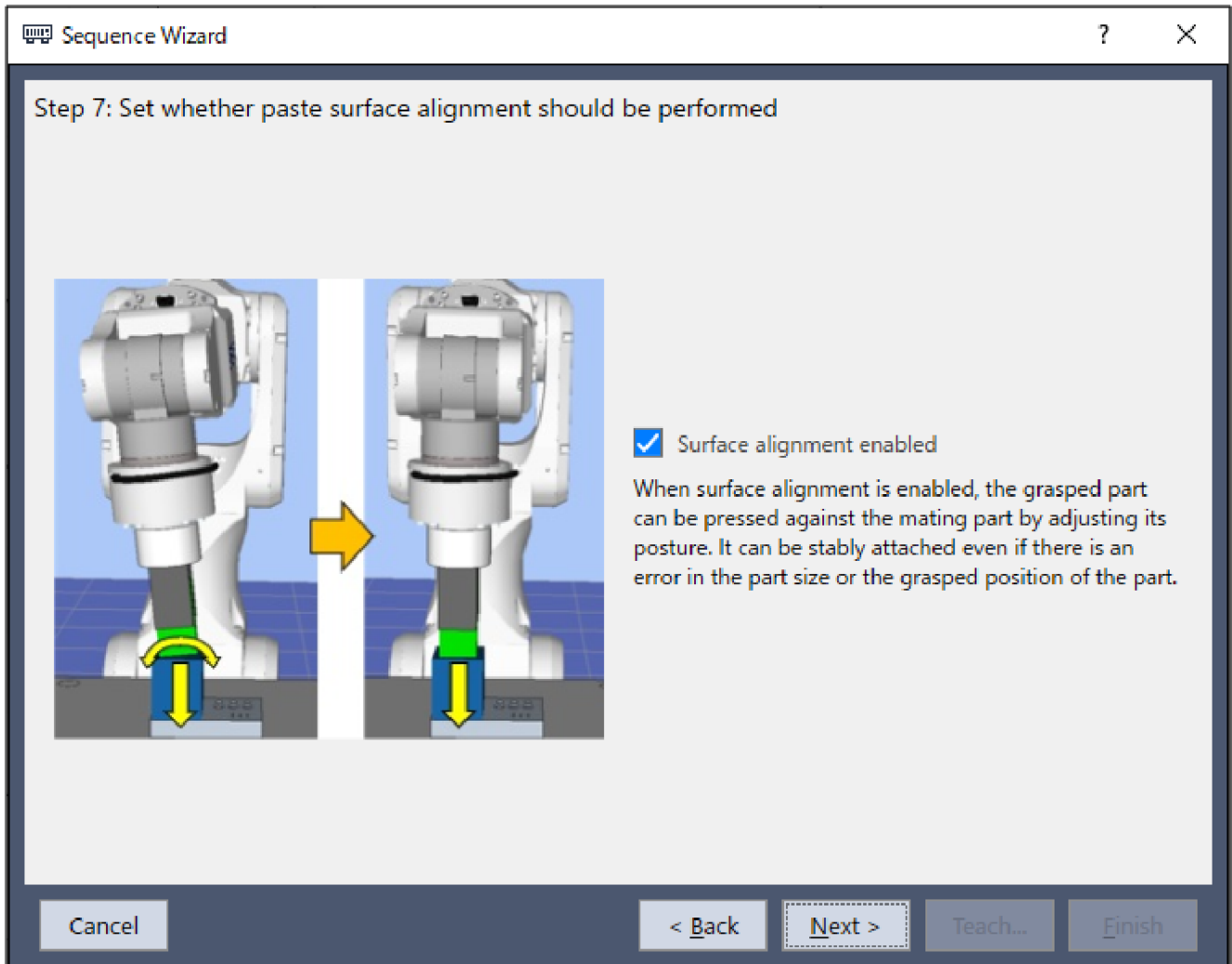

8. The [Step 8: Set paste approach distance] dialog box is displayed.

Change the properties according to the table below. Click the [Next] button.

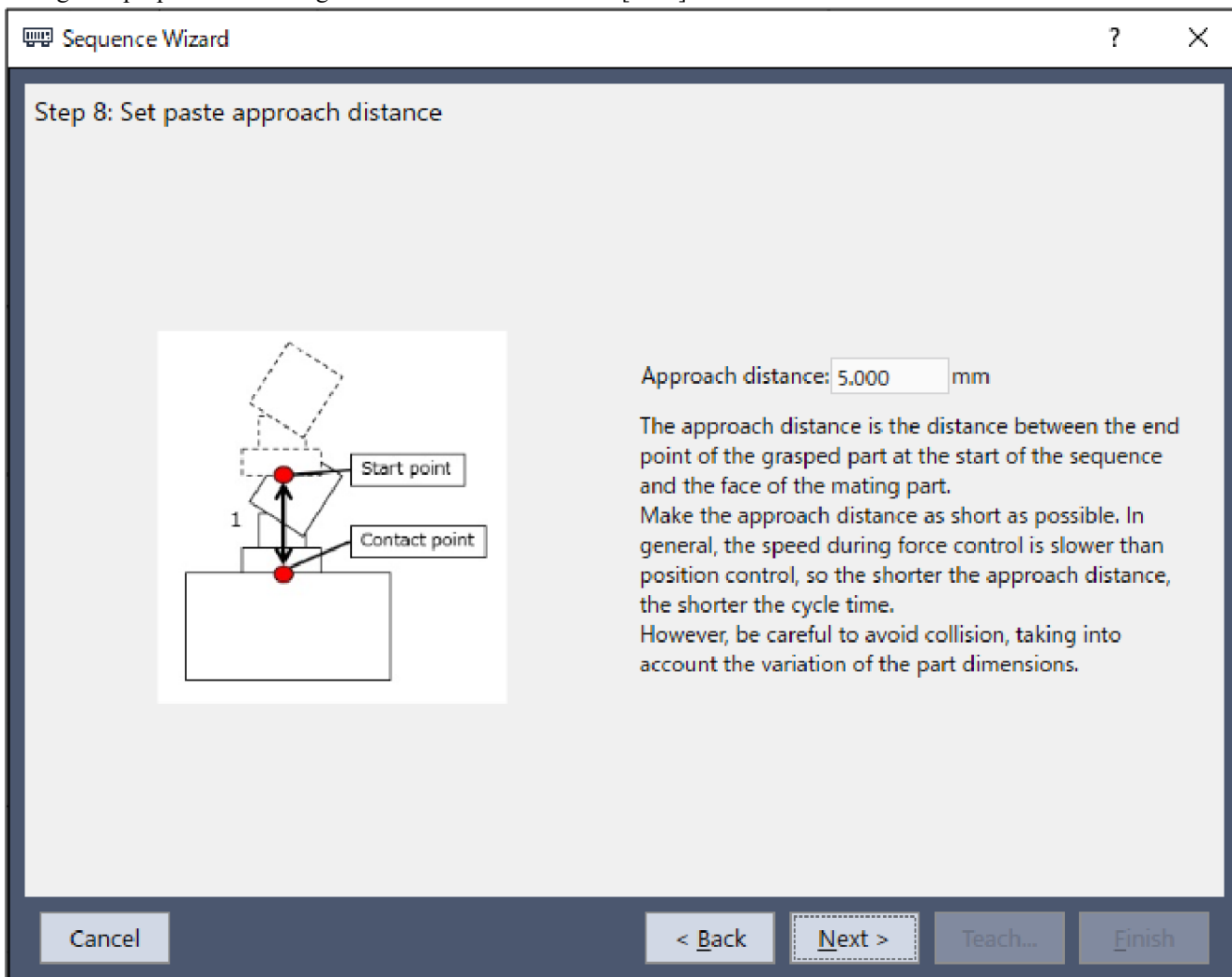

Item	Value	Description
Approach distance	5	Set the distance from the end of the gripped workpiece to the object face to be pasted. Set this to 5mm.

9. The [Step 9: Set paste force] dialog box is displayed. Change the properties according to the table below. Click the [Next] button.

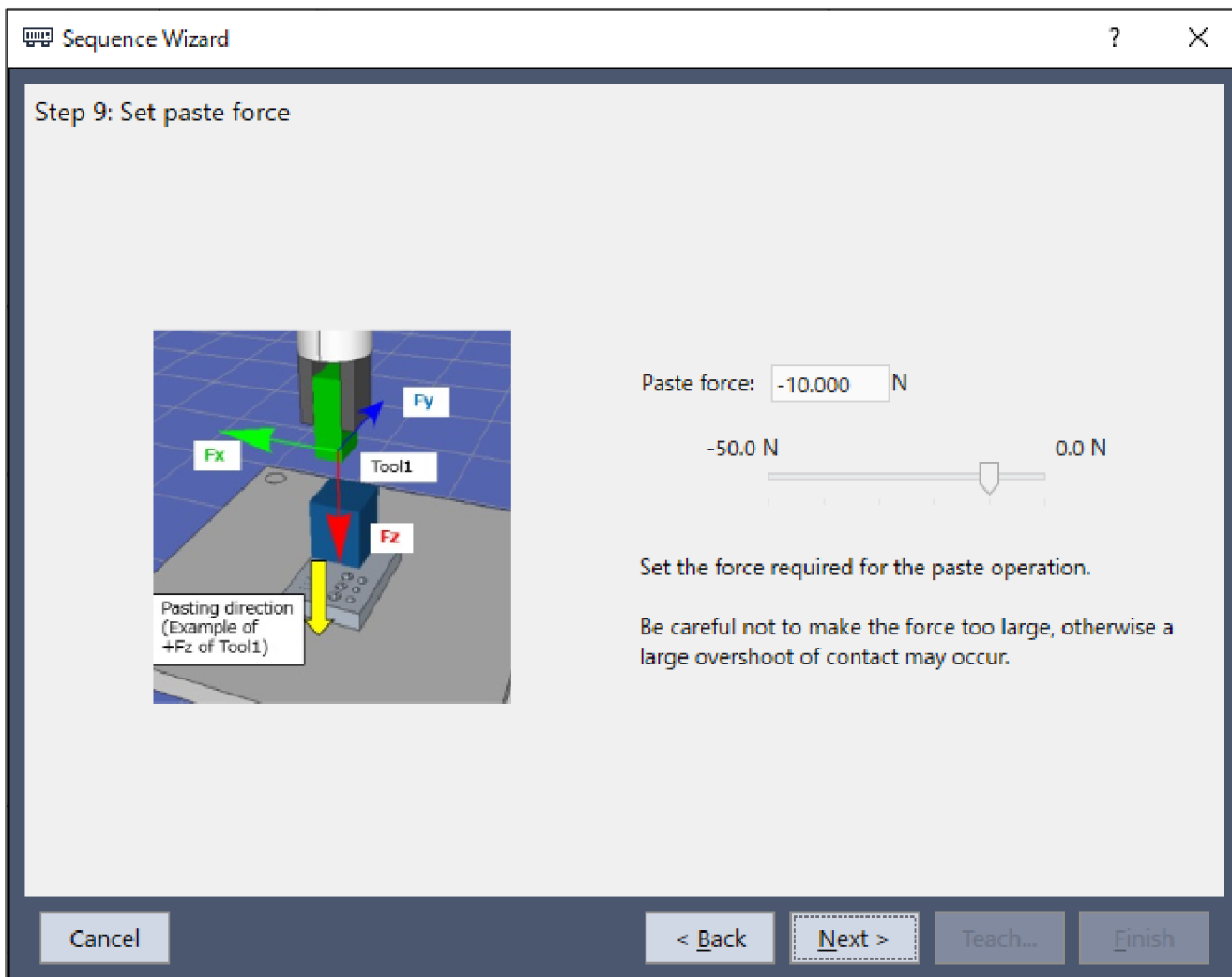

Item	Value	Description
Paste force	-10	Set the paste force. Set this to -10N. Set this to a tolerable value considering the workpiece in use.

10. The [Step 10: Set paste firmness] dialog box is displayed.
Select [Set align firmness manually (advanced)].

Change the properties according to the table below.

Click the [Next] button.

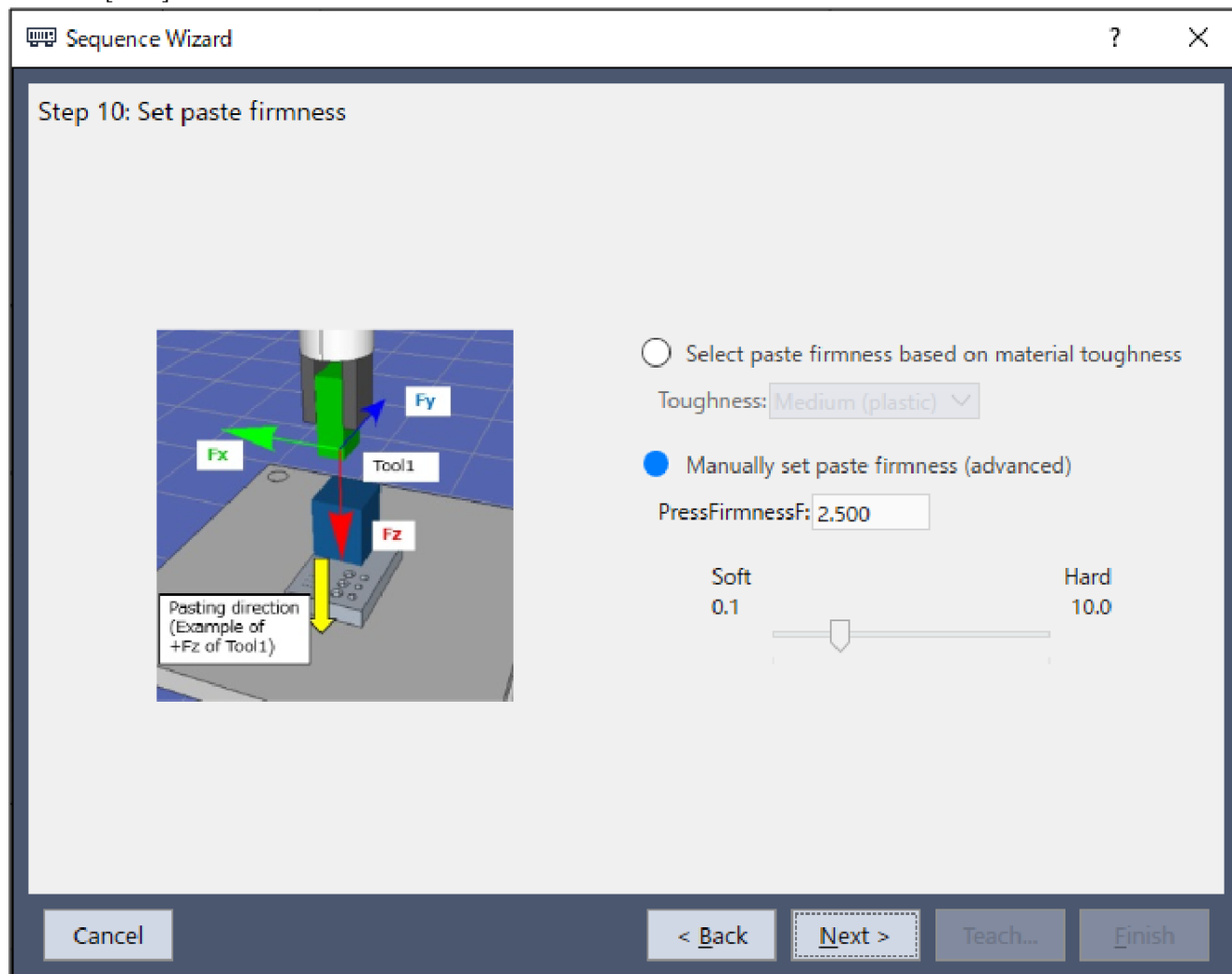

Item	Value	Description
PressFirmnessF	2.5	Set the firmness of the force control function in the direction of pasting. Set this to 2.5.

11. The [Step 11: Set paste surface alignment firmness] dialog box is displayed.

Select [Set align firmness manually (advanced)].

Change the properties according to the table below.

Click the [Next] button.

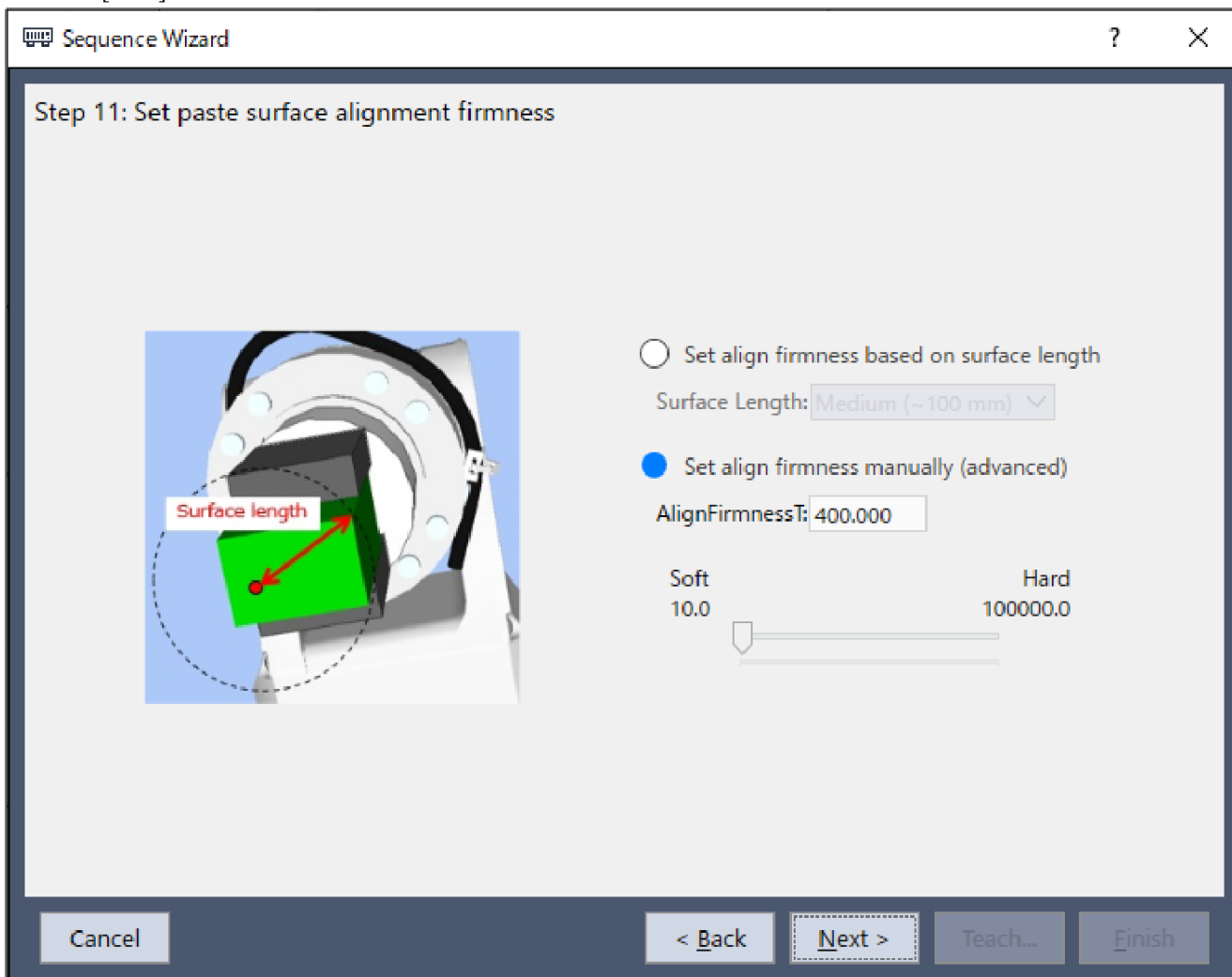

Item	Value	Description
AlignFirmnessT	400	Set the firmness of the force control function in the direction of surface alignment. Set this to 400.

12. The [Step 12: Configure the completion conditions for the paste operation] dialog box is displayed.

Change the properties according to the table below.

Click the [Next] button.

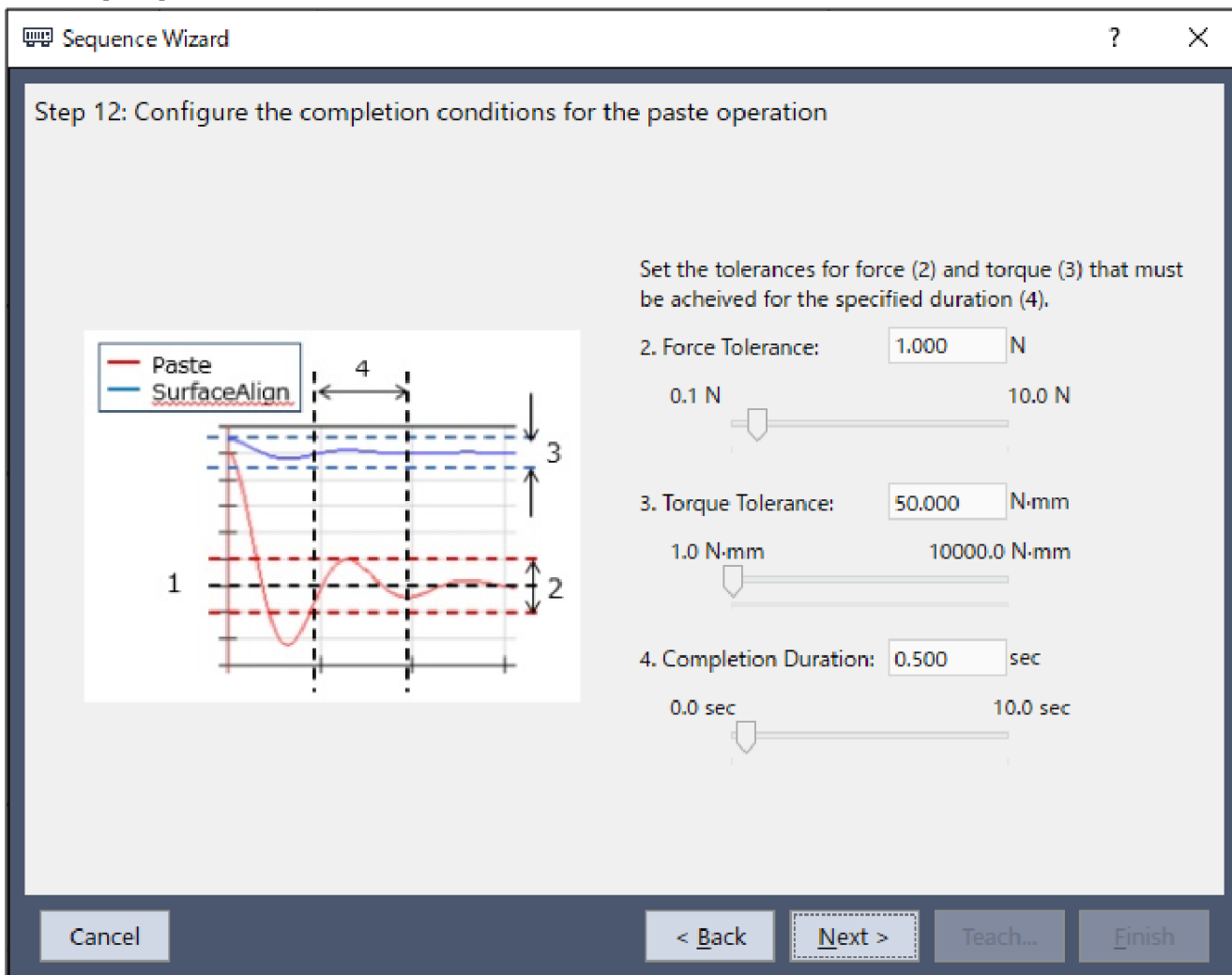

Item	Value	Description
Force Tolerance	1	Set the range to use as the end condition related to force. Set this to 1N.
Torque Tolerance	50	Set the range to use as the end condition related to torque. Set this to 50 Nmm.
Completion Duration	0.5	Set the duration at which end conditions are deemed to have been met. Set this to 0.5 seconds.

13. The [Step 13: Set the timeout for the operation] dialog box is displayed.

Change the properties according to the table below. Click the [Next] button.

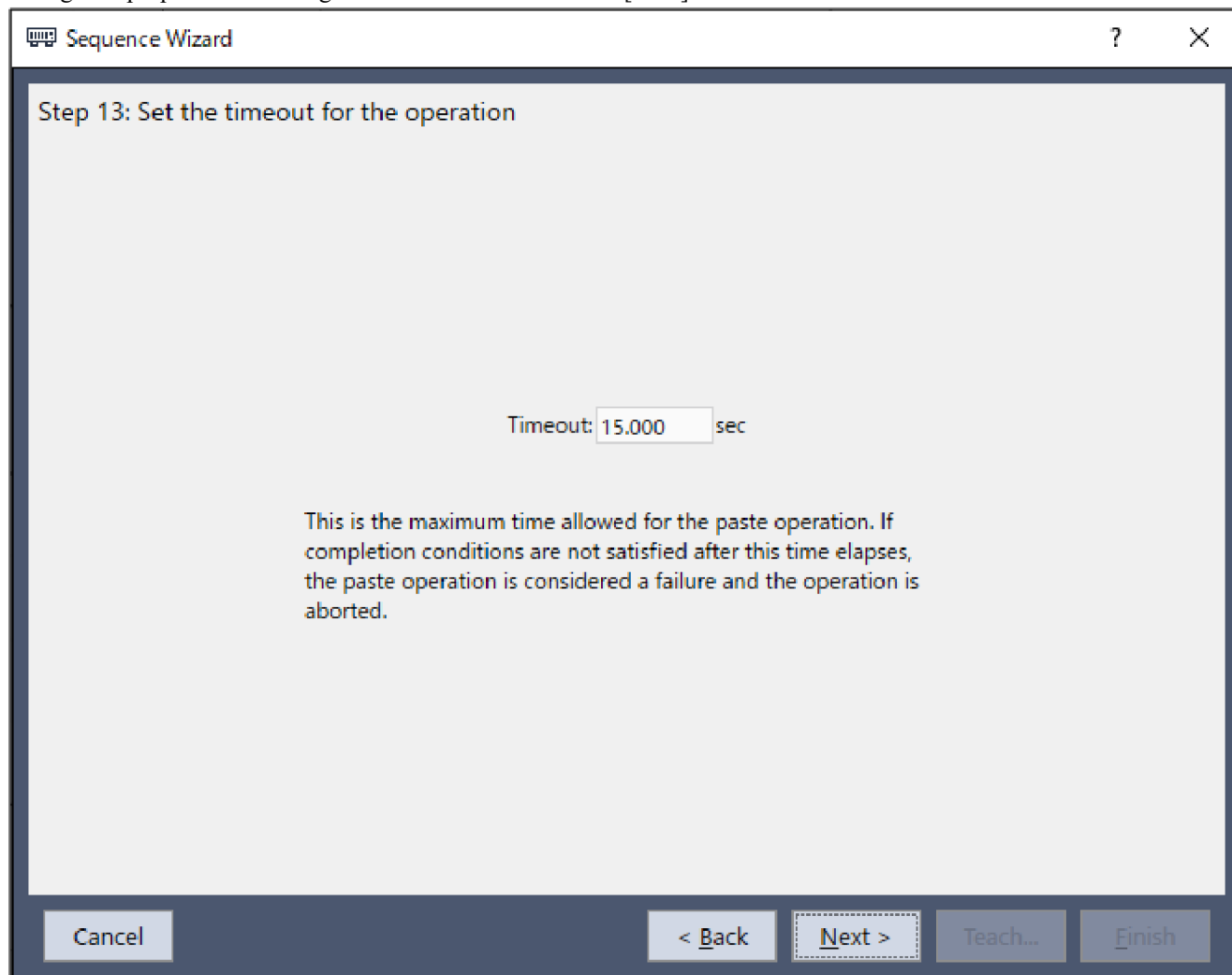

Item	Value	Description
Timeout	15	Set the time-out duration. Set this to 15 seconds.

- 14. The [Finish] dialog box is displayed.
Click the [Finish] button.

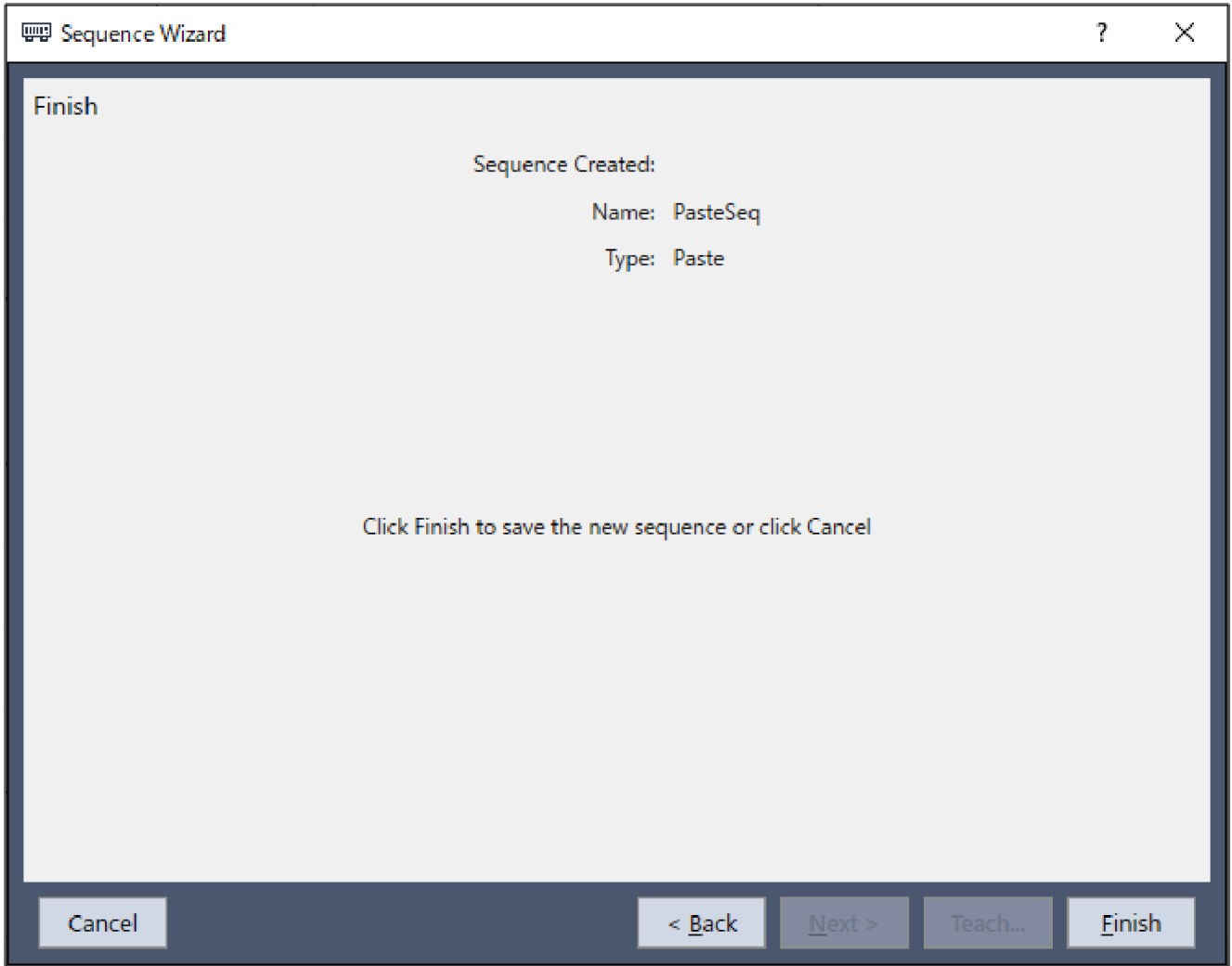

- 15. Check that the [PasteSeq] sequence has been created.

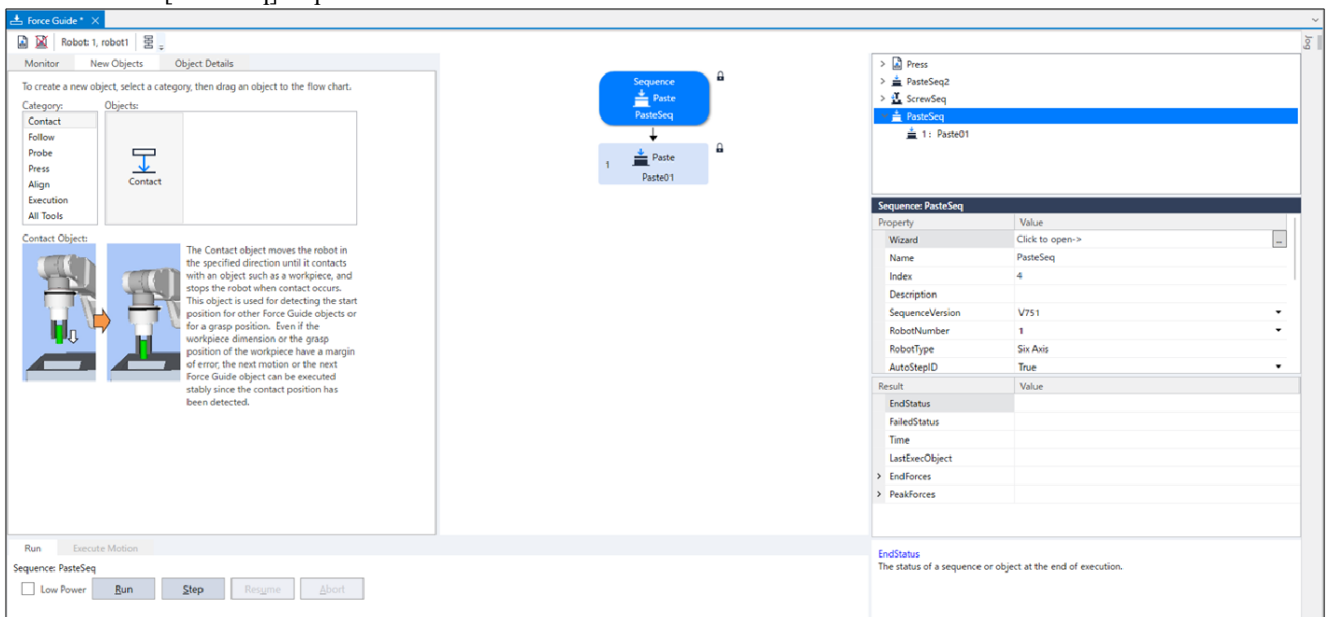

4.6.3.1.4 Setting Confirmation

The following describes how to check whether the settings for pasting direction are correct by using a simulator.

1. Click Epson RC+ menu-[Tools]-[Simulator].
The [Simulator] window is displayed.
2. Click the object tree-[Tool].
Place a checkmark in the "No.1"-[Visible] check box. An arrow for "Tool 1" is displayed.
3. Click the object tree-[Force]-[Force Guide]-[PasteSeq].
Place a checkmark in the "Paste01"-[Visible] check box.

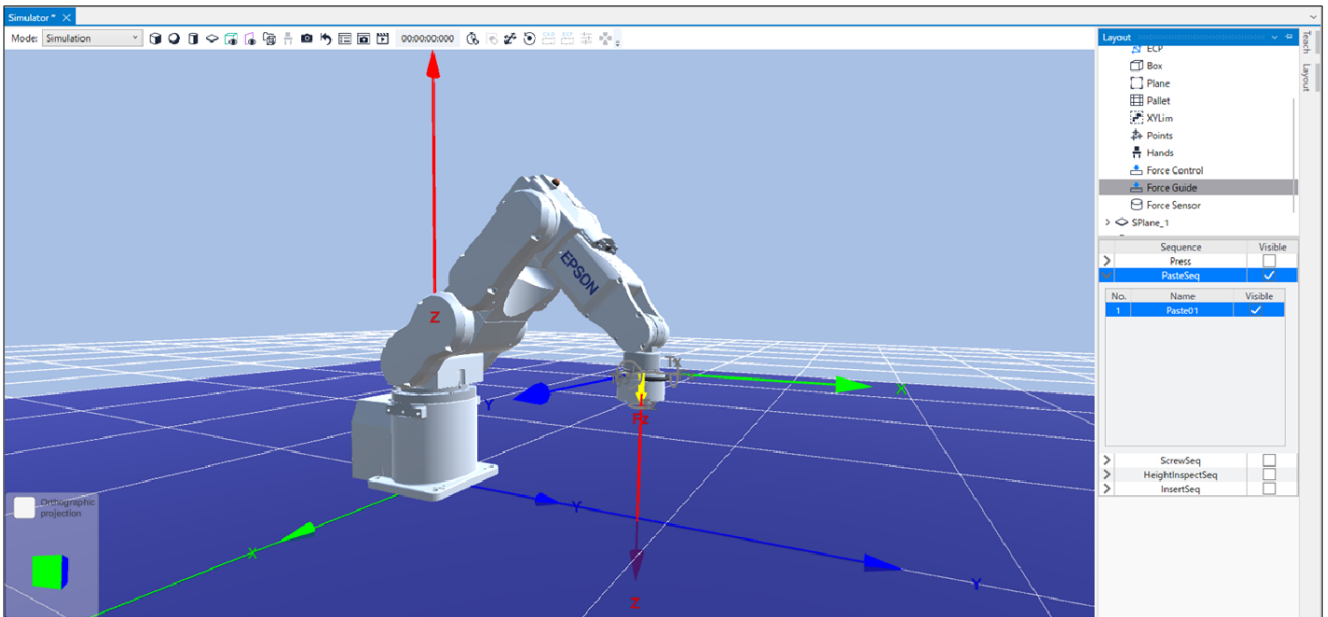

Confirm that the yellow arrow direction is the same as the pasting direction.

4.6.3.1.5 Motion by Force Guidance Function

The following describes how to run the created Paste sequence by Epson RC+.

1. Open the [Force Guide] window.
2. Select the [Jog] tab.
3. Click the [POWER HIGH] button.
If the robot might break the workpiece, operate in "Low Power Mode".
4. Click the [Execute] button.
Program is compiled and transmitted to the Robot Controller.
If the setting is not correct, an error occurs.
Check the settings so far and follow the error message to modify the parameters.

5. When the operation is performed properly,  is displayed on the upper left of the flowchart and the pasting is completed.

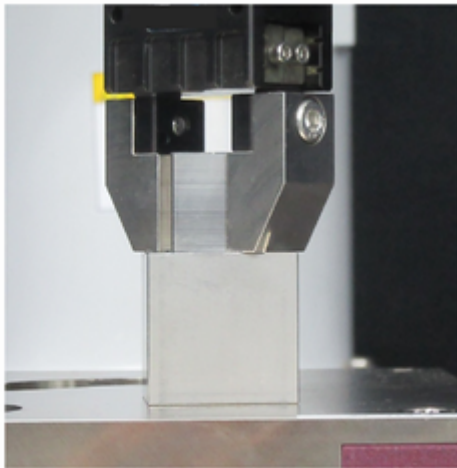
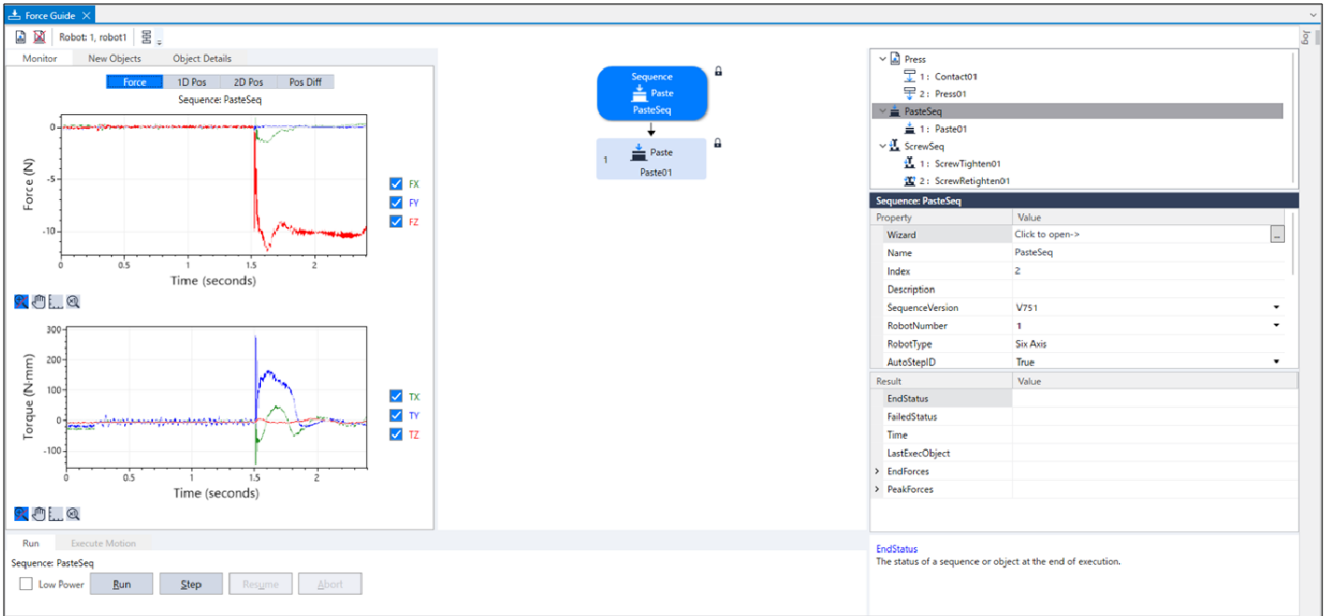

4.6.3.1.6 Return to the Non-Contact State

After completing the Paste sequence, force continues to be applied to between the robot and the workpiece. To prevent the robot and the end effector from malfunction or damages, after the operation ends, make sure that no force is applied to the object.

If it is obvious that no force is applied to the object, you can omit this step.

Steps to return to a non-contact state are as follows:

- Click Epson RC+ menu-[Tools]-[Robot Manager]-[Jog & Teach] panel-[Jog] group and perform jog motion manually to move the robot away from the object.
- Click Epson RC+ menu-[Tools]-[Robot Manager]-[Jog & Teach] panel-[Execute Motion] tab and move the robot away from the object.
- Execute Move command on [Command Window] and move the robot away from the object.
- Add SPelfunc object after Press object, and automatically move the robot away from the object at the end of the force guide sequence.

The following describes how to return to non-contact state by clicking [Robot Manager]-[Jog & Teach]-[Execute Motion] tab.

1. Display the [Robot Manager] dialog box.
2. Click the [Jog & Teach] tab.
3. Select the [Execute Motion] tab.

- 4. Select "Move" in [Command].
- 5. Select "P1" in [Destination].
- 6. Click the [Execute] button.

The robot moves to the start point: P1. Now, it is the non-contact state.

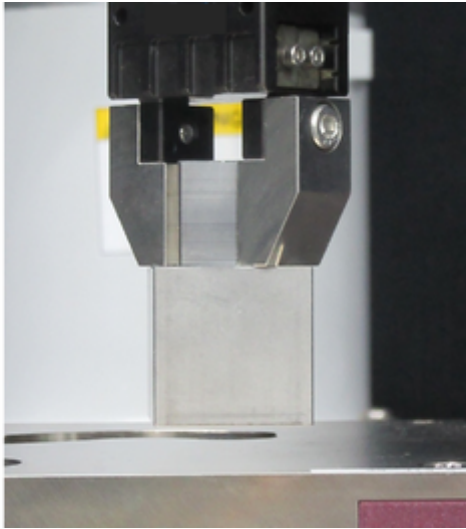

4.6.3.1.7 Motion Analysis by Monitor

The following described how to check the motion results of force guide sequence by Epson RC+.

- 1. Open the [Force Guide] window.
- 2. Click the sequence flow of [PasteSeq].
- 3. Select the [Monitor] tab. Select the [Force] tab.

Force and position during the [PasteSeq] sequence execution are displayed in the graph.

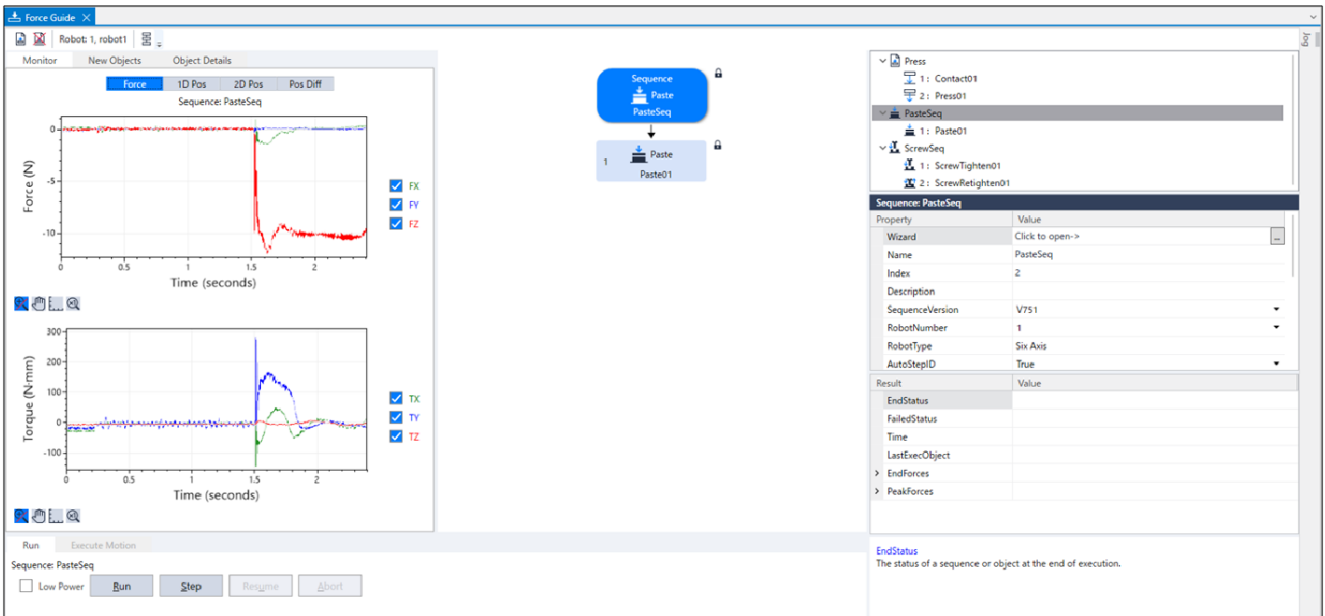

- 4. Select the [1D Pos] tab.

Graph for analysis is displayed. (horizontal axis: Time, vertical axis: Position)

As you can see by looking the Position Z graph, CurZ (current position) is lowered by about 5mm. It indicates that the robot moves 5mm of the approach distance in the pasting direction.

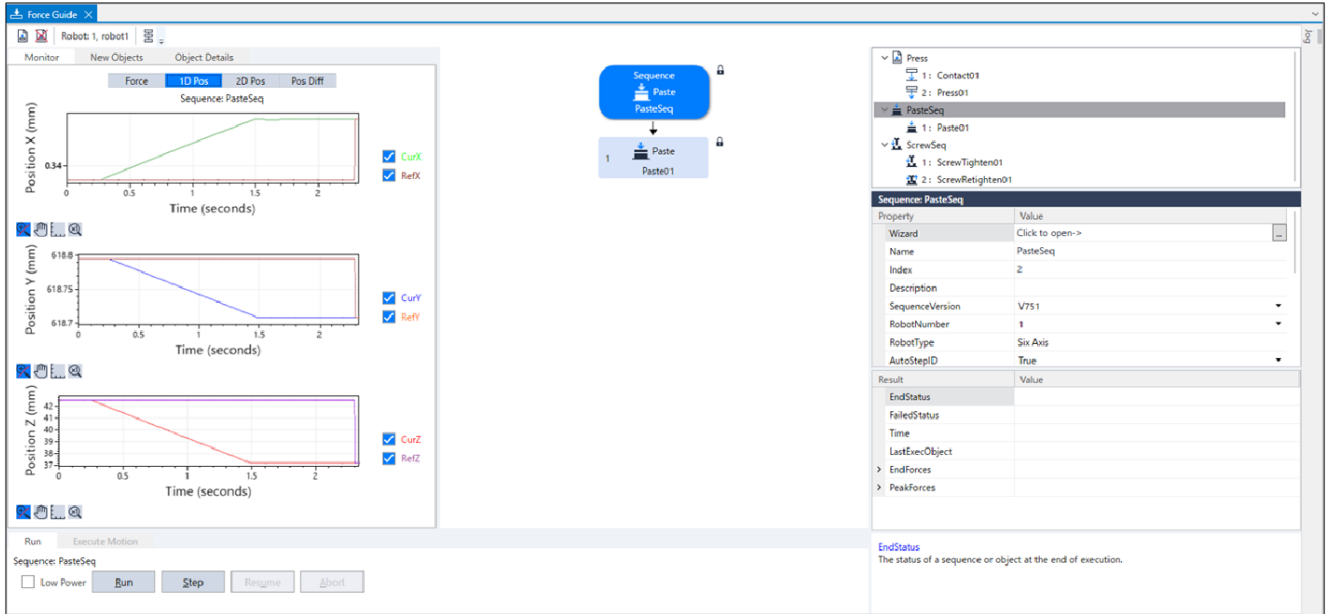

5. Select the [2D Pos] tab.

Graph for analysis is displayed. (horizontal axis, vertical axis: Position)

You can see what you have checked on the [1D Pos] tab as a graph projected on each plane.

Be careful of the scale difference of horizontal axis and vertical axis when checking the graphs.

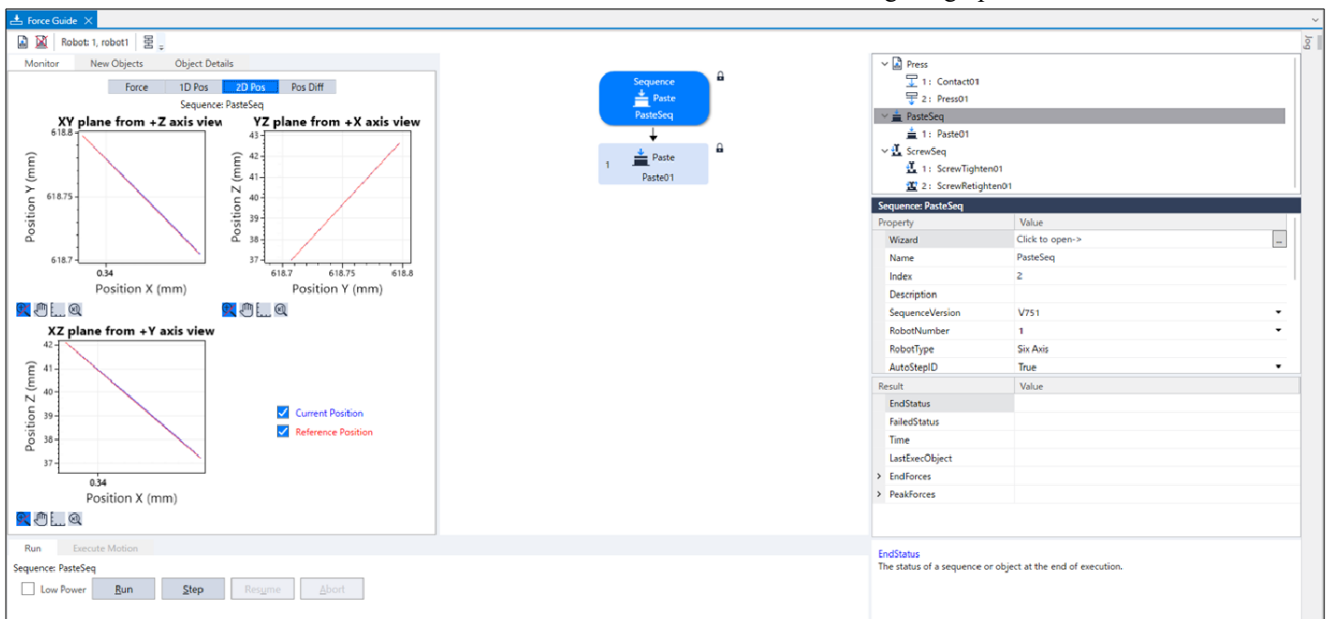

6. Select the [Pos Diff] tab.

Record shifts by force control as relative position changes.

It is different from the graph on the [1D Pos] tab.

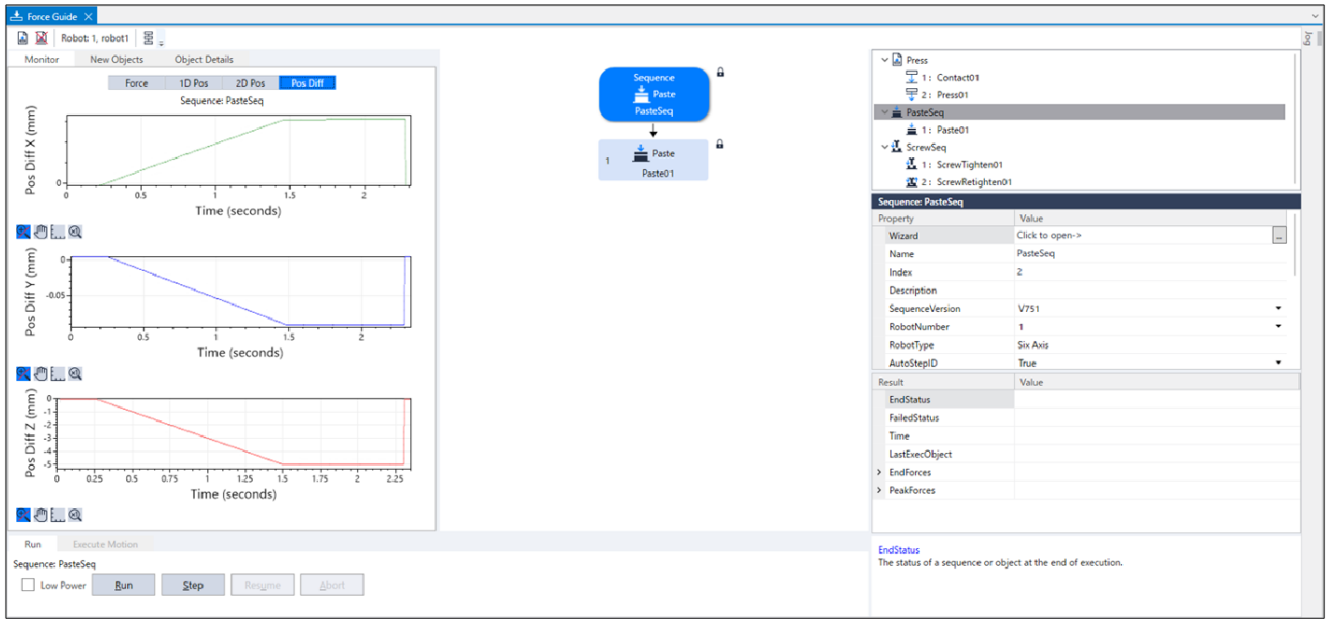

7. Change the unit of the graph and check the changes of force or positions.

If it is not pasted correctly, the setting may not be correct.

Refer to the following and check the procedures of the tutorial.

- Whether a pressing force direction is correct
- Whether the setting of the approach distance is correct
- Whether the Tool setting is correct

4.6.3.1.8 Advanced Tasks

Let's do the following advanced tasks.

The default end condition for the Paste sequence position is whether the position of the object from the start of the Paste sequence is within "the approach distance $\pm 1\text{mm}$ ".

By changing the end condition of the position, it may be possible to detect dimensional abnormalities of workpieces.

When the end condition of the position cannot be met, the sequence is determined to be failure and the operation ends.

Now try setting a failure condition.

1. Change the [Paste01] property as follows.

Item	Value	Description
DistCheckTol	0.1	Specify the success condition range for distance moved from the motion start point. Set the success condition range to "the approach distance $\pm 0.1\text{mm}$ ".

2. Select the [Jog] tab to move the robot to the start point "P1".

3. To simulate that the height dimension of the workpiece being gripped is 0.5mm smaller, move the robot 0.5mm in the +Z direction from the start point "P1" in the [Jog] tab.

4. Now try running the sequence.

This ends the Paste sequence tutorial.

4.6.3.2 ScrewTighten Sequence

The following describes how to perform a screw tightening operation using the ScrewTighten sequence of the system force guide sequence.

Prepare an electric screwdriver, screws, and a workpiece to fix screws. Incorrect settings may result in damage of the workpieces. Prepare workpieces that can be damaged, and proceed with this tutorial.

This tutorial uses the example of tightening screws using M2 screws with a length of 5mm and a lead length of 0.4mm. To proceed with the tutorial, it is necessary to change the parameters according to the electric screwdriver and screws you prepared. Set the arrangement and screw tightening direction of a workpiece in the same way as the image below.

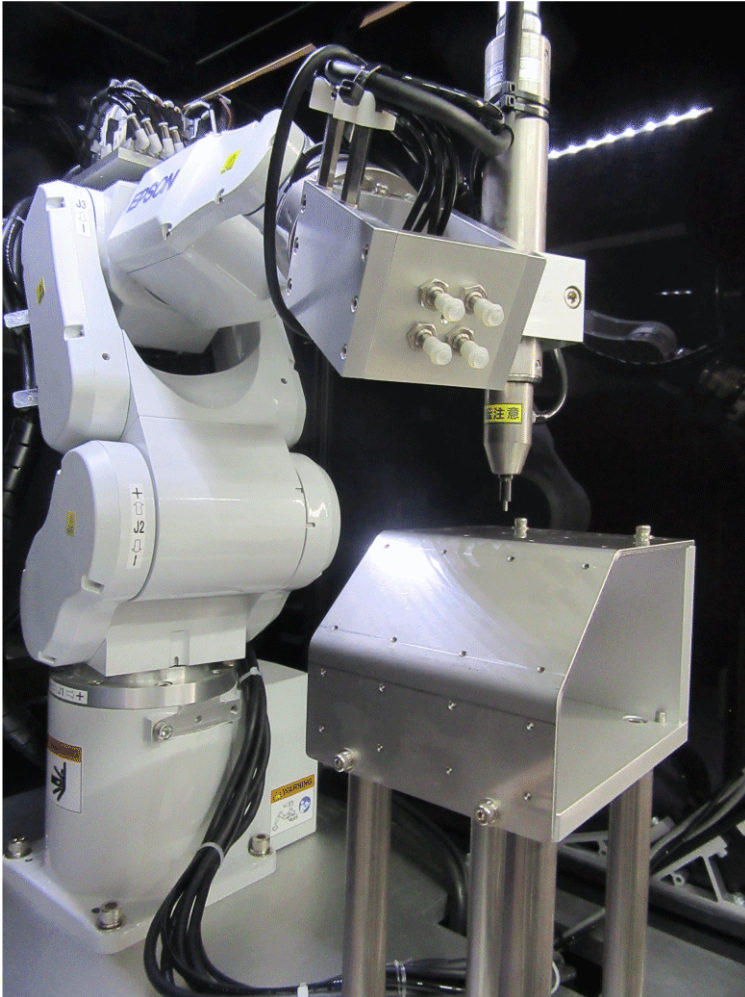

⚠ CAUTION

The parameters described in the example on the following pages are reference values.

This tutorial uses relatively stable parameters, but depending on the operating environment, the operation may not be successful or the motion may be vibratory. Note that adjusting the parameters may be required. note that Slow, stable parameters are used for convenience of explanation. For high-speed operation, adjusting the parameters is required.

4.6.3.2.1 Confirmation of Tool and Hand Setting

The following describes tool setting procedures.

In the ScrewTighten sequence, you need to consider the behavior of the actual screw tightening direction and the current tool settings.

1. Use a caliper to measure the distance of X, Y, and Z from the J6 flange plane to the end of the electric screwdriver.

2. Execute the following in [Command Window].

Enter the values measured in procedure (1) in "LengthX, LengthY, LengthZ".

```
> Tlset 1,XY(LengthX,LengthY,LengthZ,0,0,0)
```

3. Click Epson RC+ menu-[Tools]-[Simulator].

The [Simulator] window is displayed.

4. Select the object tree-[Manipulator Name]-[Tool].

5. Place a checkmark in "No.1"-[Visible] check box.

6. To confirm that the tool setting is correct, compare the display of the [Simulator] window and the orientation of the actual robot.

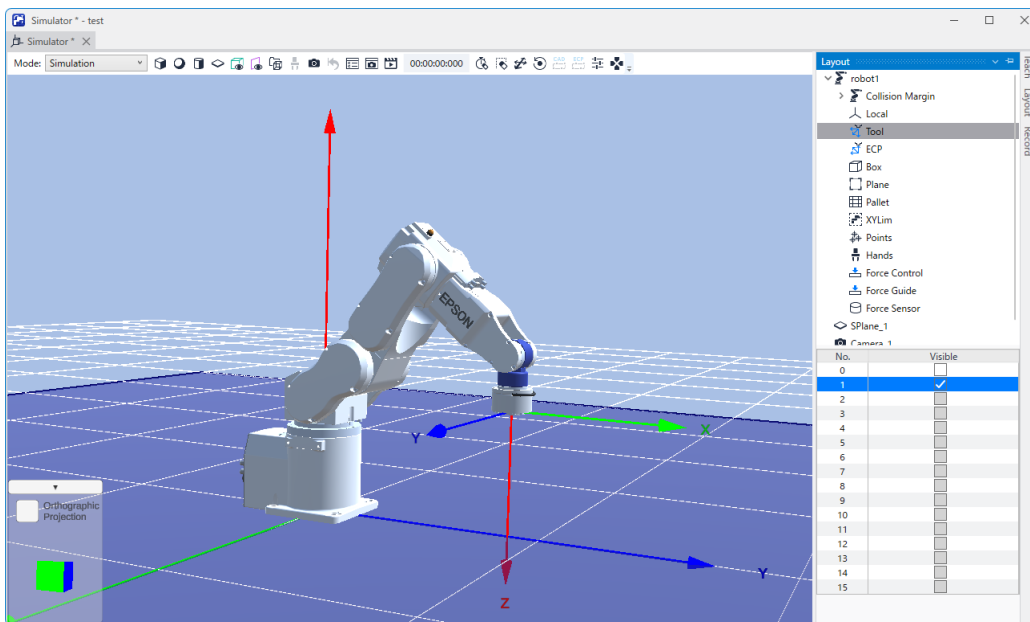

According to the display of the [Simulator] window, you will see that screw driving is performed to +Z direction of the tool.

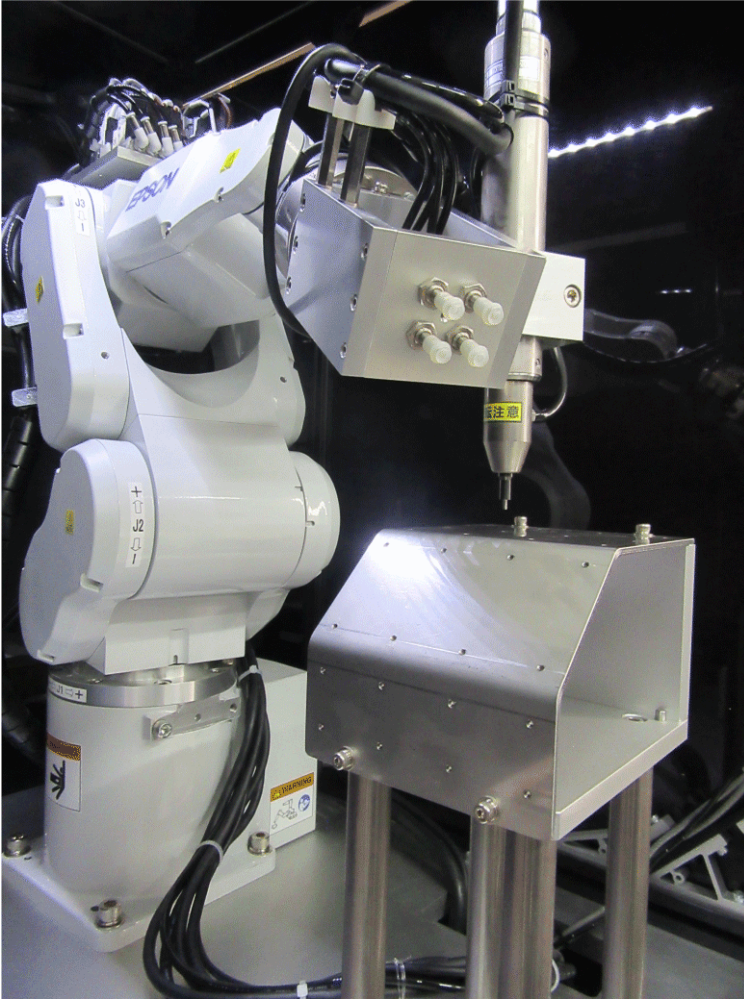

The following describes Hand setting procedures.

Allocate the forward and reverse rotation of the electric screwdriver to the output bit of the controller I/O, and allocate the screw tightening completion signal to the input bit of the controller I/O.

1. Click Epson RC+ menu-[Tools]-[Robot Manager]. The [Robot Manager] dialog box appears.

2. Select the [Hands] panel and open the panel.

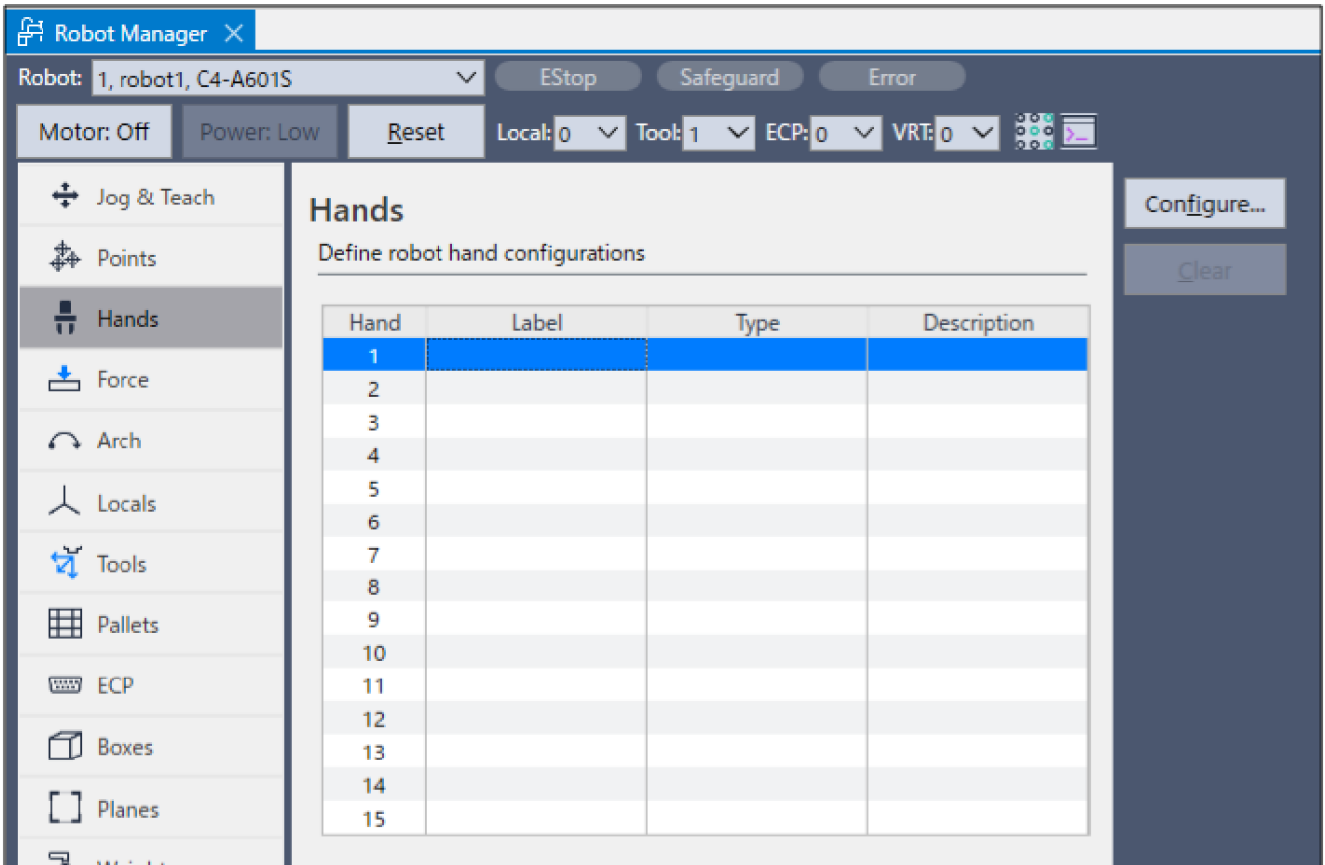

3. Select "Hand 1" and click the [Configure...] button.

The configuration screen for Hand 1 is opened.

4. Place a checkmark in the [Defined] check box, and change the following items.

Item		Value	Description
Label		driver1	Enter a label name.
Series		Screwdrivers	Select "Screwdrivers" in [Series].
Hand_On	Start_Controller I/O Bit	Driver forward rotation bit	Set the output bit allocated to the driver forward rotation.
	Start_I/O State	On	This is the state of the driver forward rotation bit when the driver rotates forward.
	Complete_Controller I/O Bit	Completion of screw driving bit	Set the input bit allocated to the screw tightening completion signal.
	Complete_I/O State	On	This is the state of the screw tightening completion bit when the driver performs torque-up.
Hand_Off	Start_Controller I/O Bit	Driver reverse rotation bit	Set the output bit allocated to the driver reverse rotation.
	Start_I/O State	On	This is the state of the driver reverse rotation bit when the driver rotates in the reverse direction.

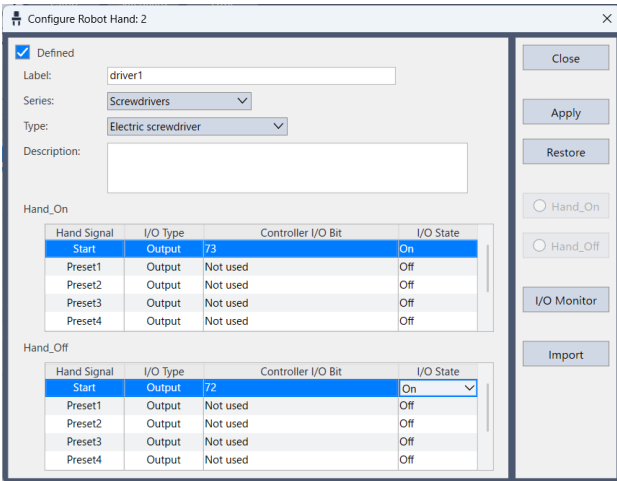

5. Click the [Apply] button to save the settings, and click the [Close] button to close the configuration screen for Hand 1.

4.6.3.2.2 Position Teaching

The following describes how to teach a sequence start position of ScrewTighten sequence.

1. Click Epson RC+ menu-[Tools]-[Robot Manager].
The [Robot Manager] dialog box appears.
2. Select [Jog & Teach] and open the panel.
3. Select "1" on [Tool].

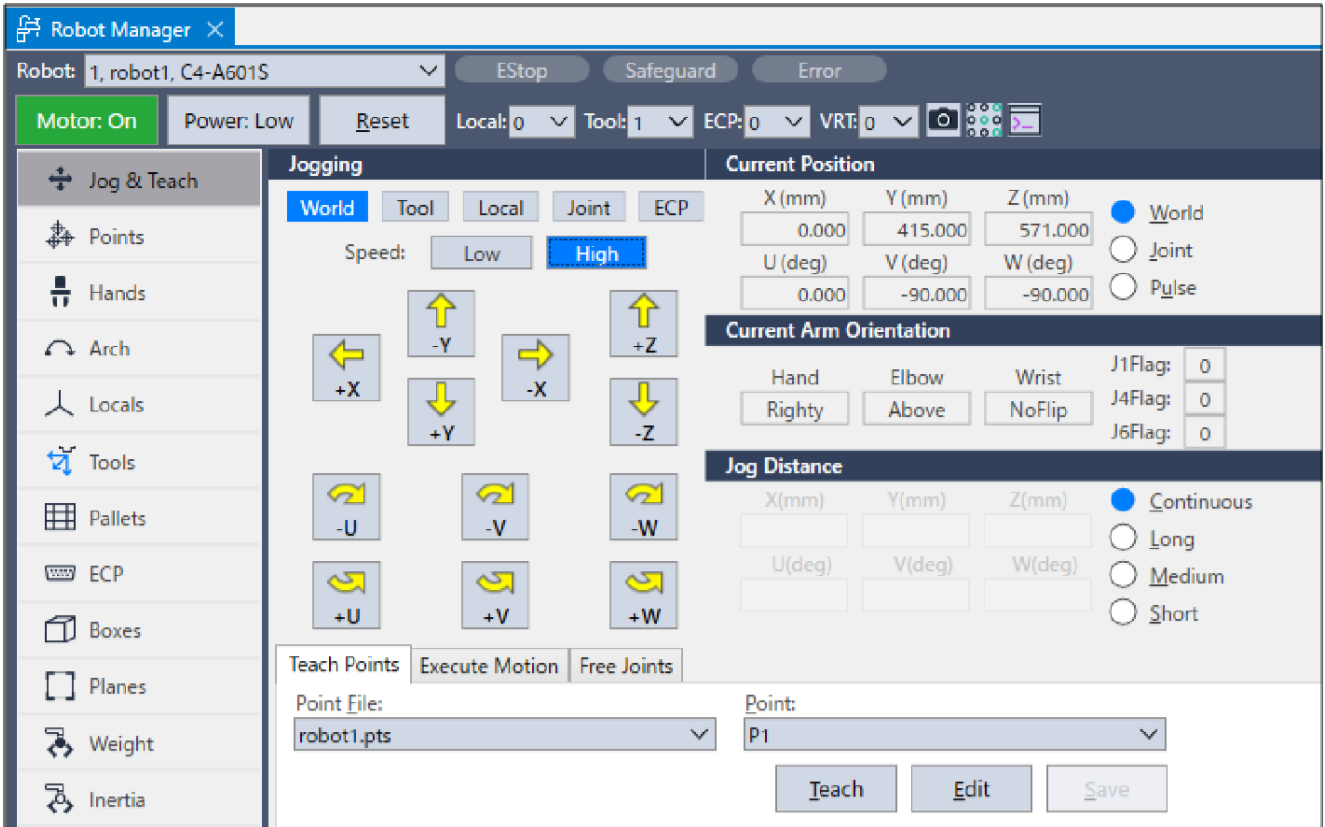

4. An electric screwdriver attaches to a screw.
5. Use the Jog button to move the robot to the following positions.
 - X and Y directions : The end of the screw is within the taper part of the screw hole

- Z direction : The end of the screw is 1mm above the screw hole

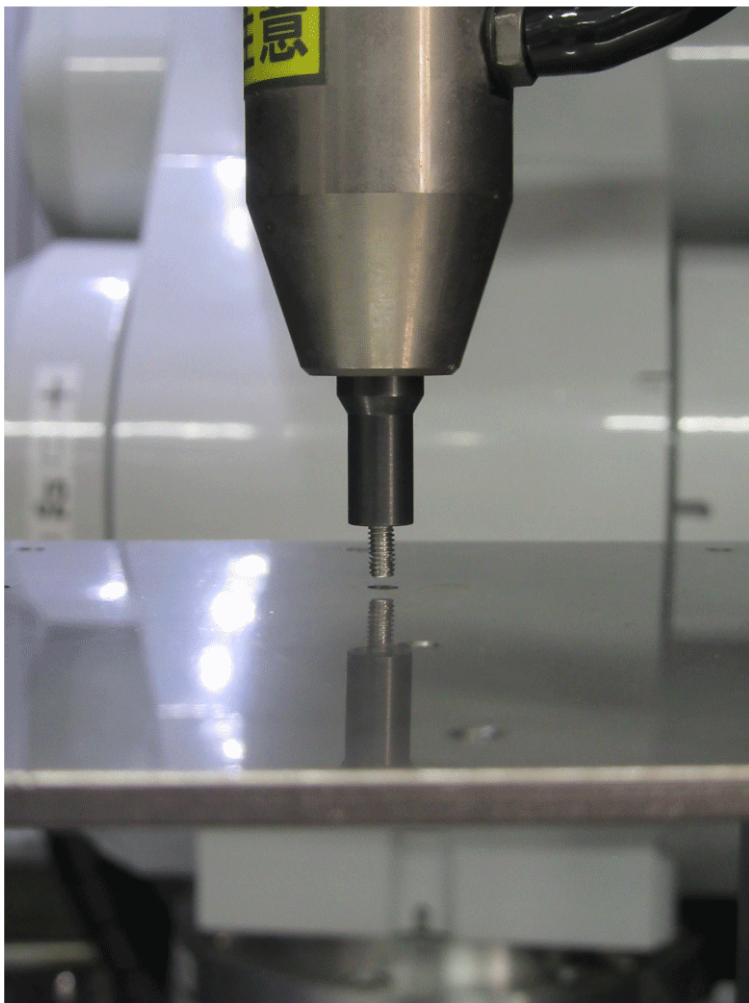

6. Select Epson RC+ menu-[Tools]-[Force Monitor]. The [Force Monitor] dialog box is displayed.

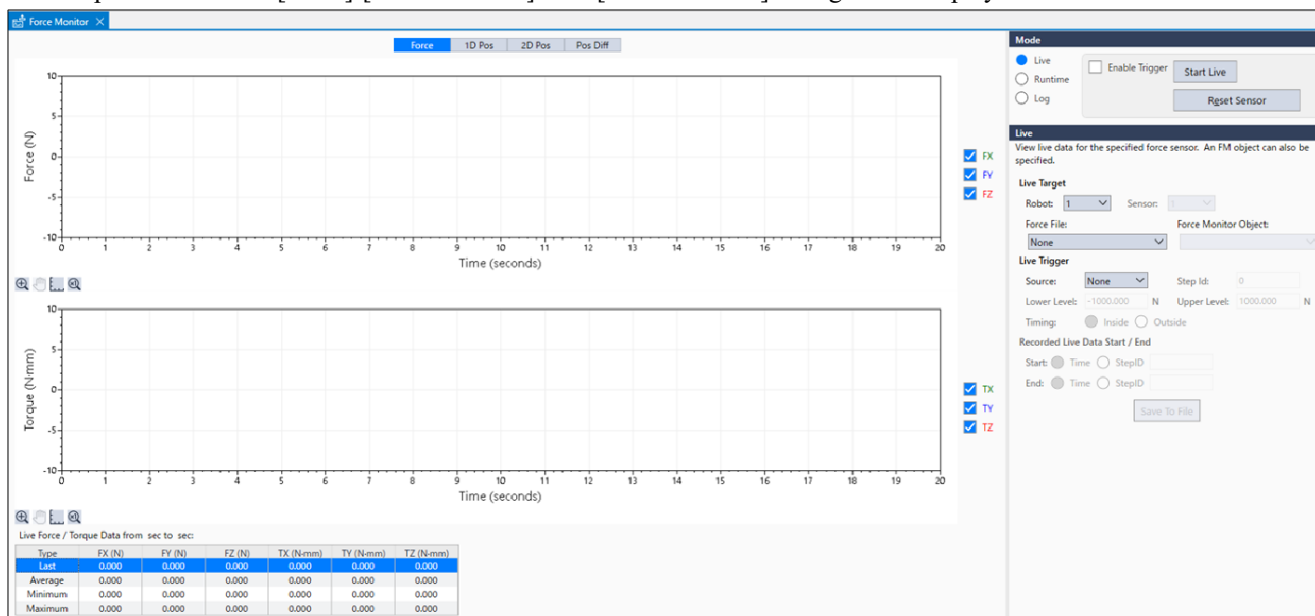

7. Select [Short] button on [Jog Distance].

Click the Jog button several times to move the robot to -Z direction until the end of screw contacts with screw hole.

When the robot contacts with the object, output value of Force Sensor changes. Check the changes of monitor value by the timing of the jog motion.



8. Select the [Medium] button on [Jog Distance].

So that the screw will be in a non-contact state, click the Jog button two times to move the robot 2mm in the +Z direction.

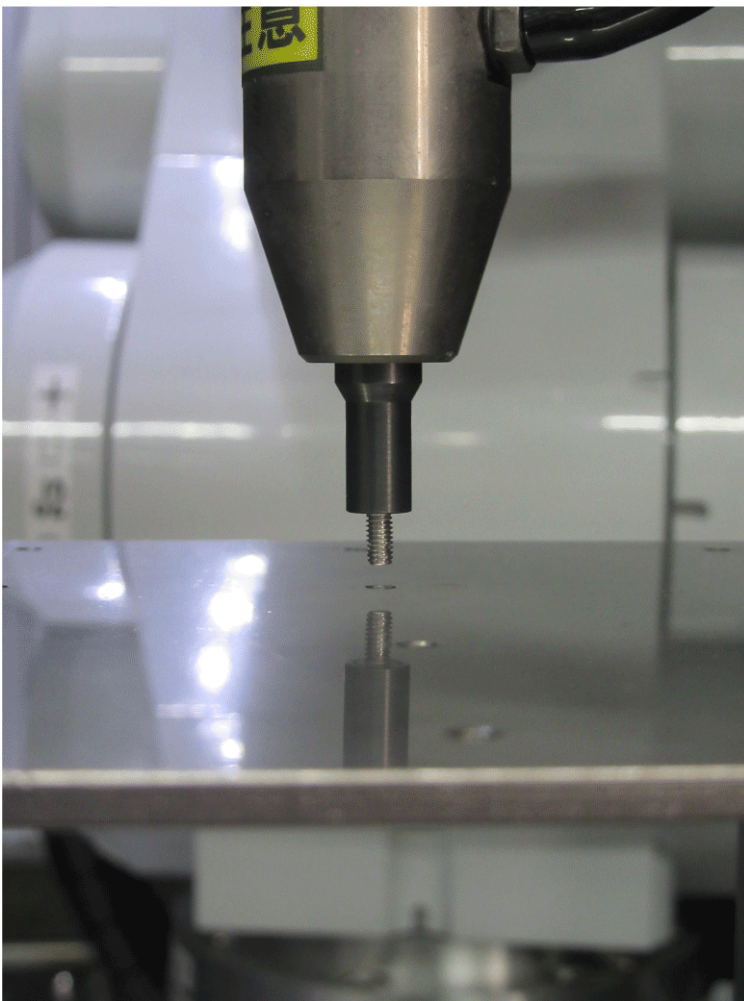

This is a start position of sequence and a position where the Force Sensor is reset.

9. Select "P1" in the [Point] dropdown.

10. Enter "ScrewStart" in [Point Label]. Click the [OK] button.
Click Epson RC+ menu-[File]-[Save All]. The file is saved.

4.6.3.2.3 Sequence wizard

The following describes how to create a dedicated force guide sequence for screw driving.

1. Enter "ScrewSeq" in the [Enter name for new sequence] box. Click the [Next] button.

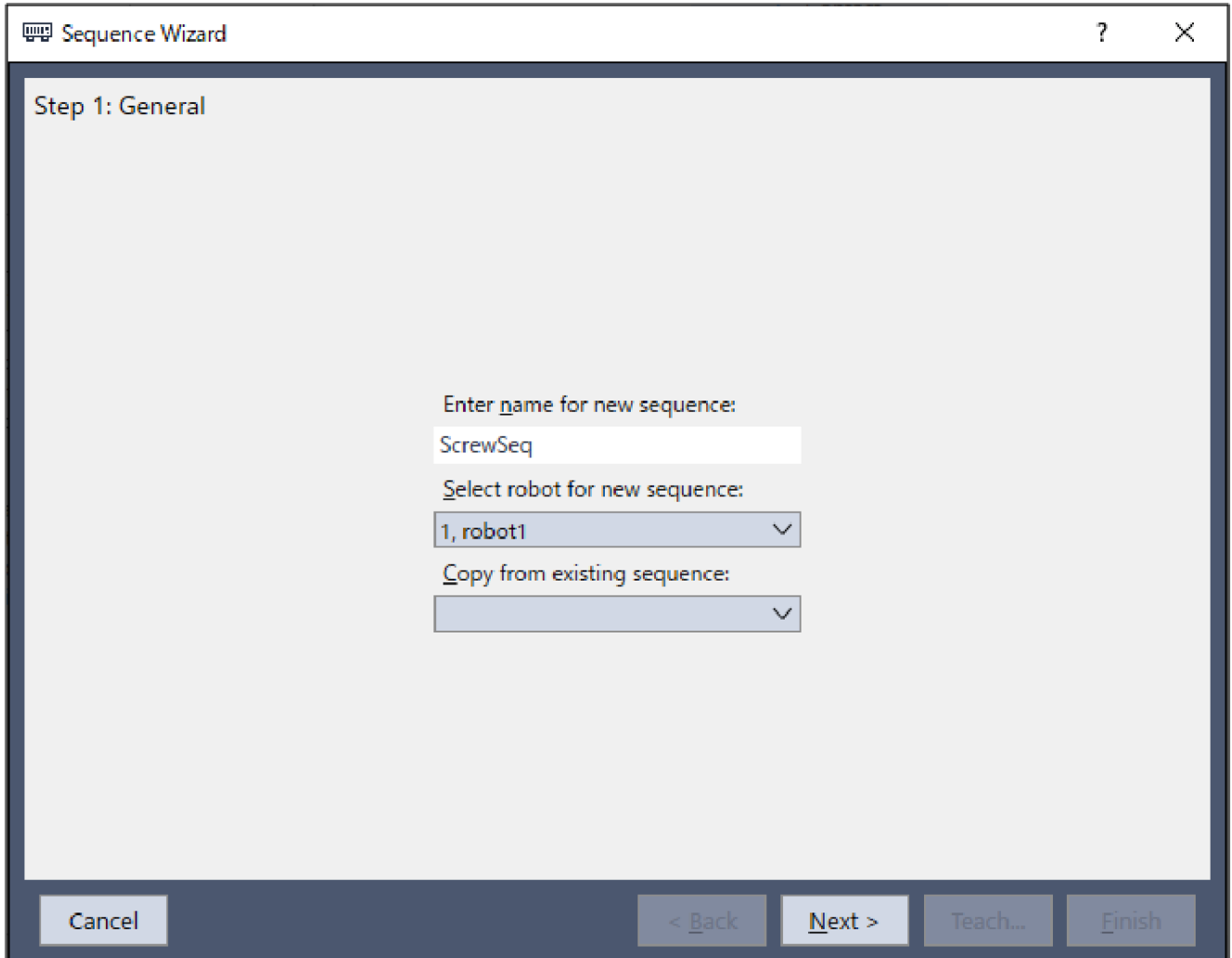

Sequence Wizard

Step 1: General

Enter name for new sequence:
ScrewSeq

Select robot for new sequence:
1, robot1

Copy from existing sequence:

Cancel < Back Next > Teach... Finish

2. The [Step 2: Select sequence type] dialog box is displayed.

Select [System].

Click the [Next] button.

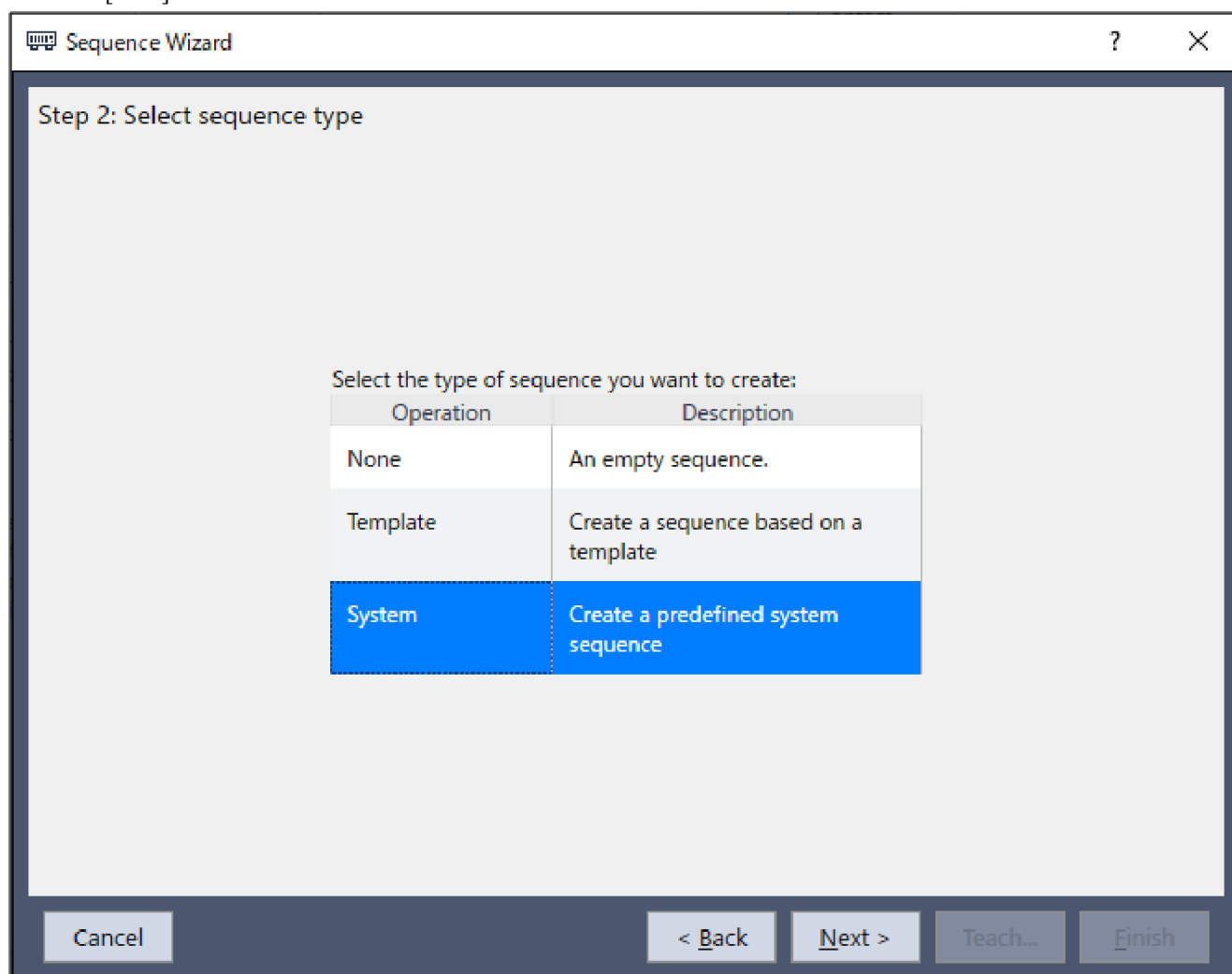

3. The [Step 3: Select system sequence] dialog box is displayed.

Select [Tighten screw].

Click the [Next] button.

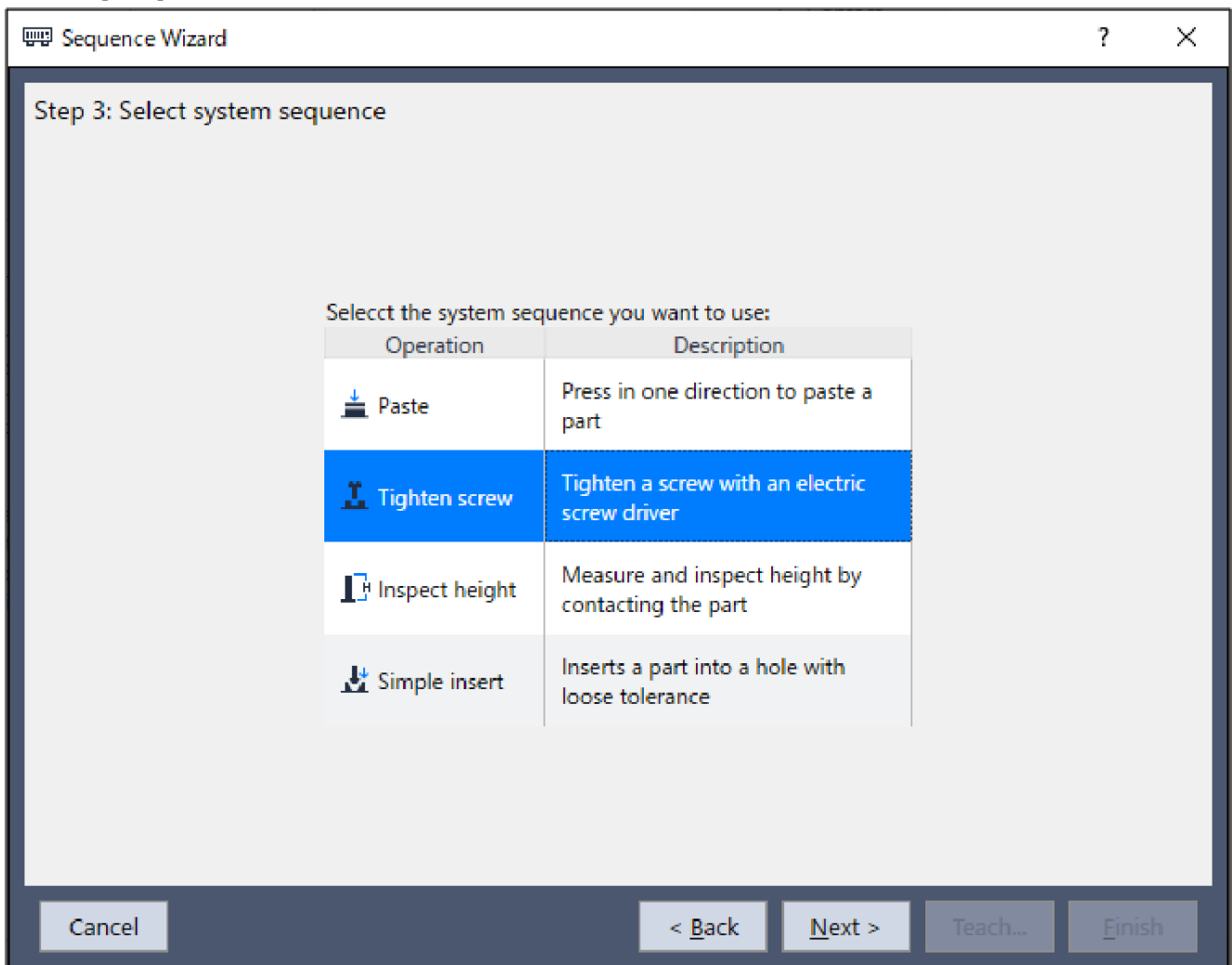

4. The [Step 4: Set screw parameters] dialog box is displayed. Change the properties according to the table below. Click the [Next] button.

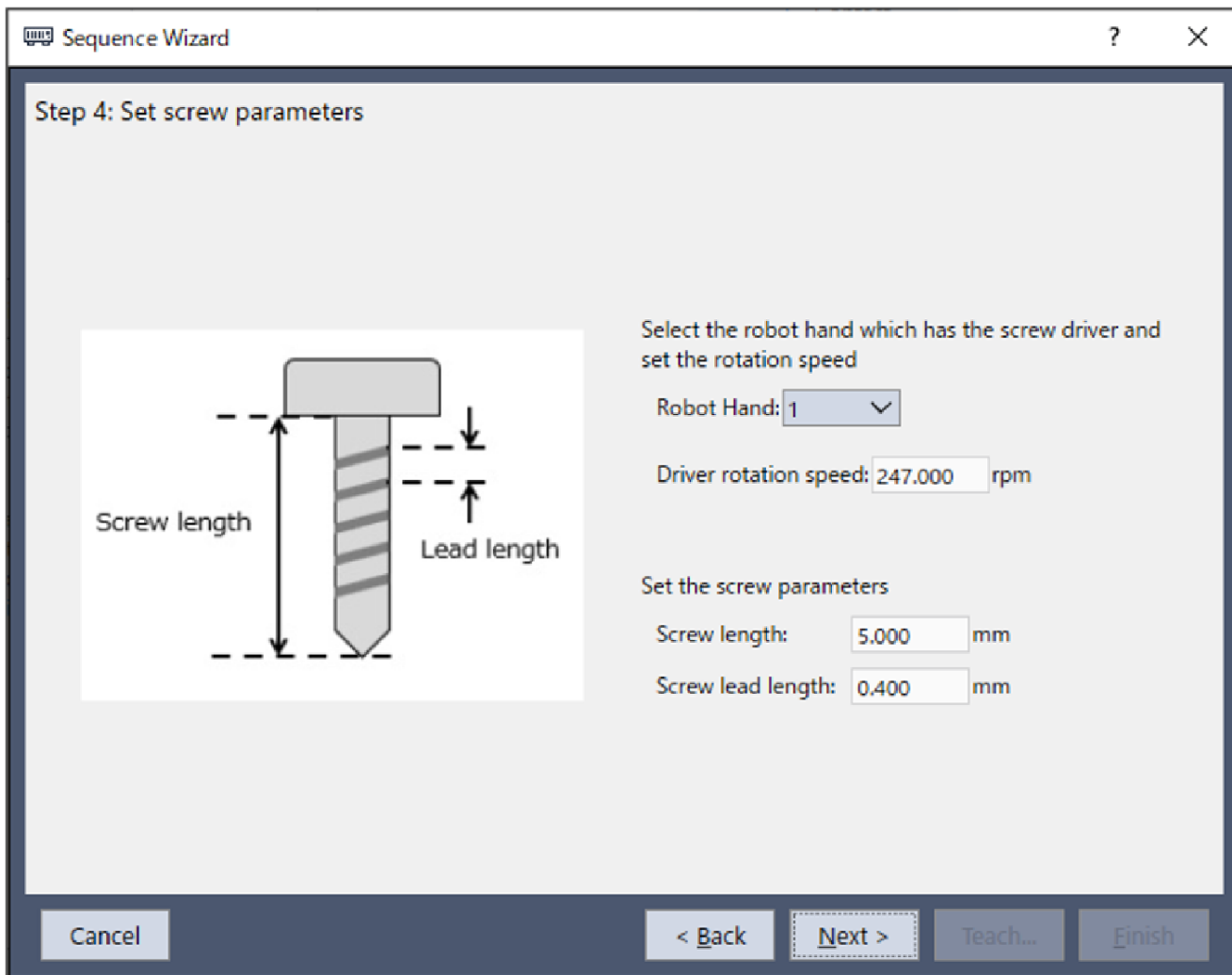

Item	Value	Description
Robot Hand	1	Specify the number set for the hand used in this sequence. The hand label will appear after the hand number.
Driver rotation speed	247	Set the rotation speed of electric screwdriver. Set this to the rotation speed of your electric screwdriver.
Screw length	5	Set the length of the screw. Set this to the length of the screw in use.
Screw lead length	0.4	Set the screw lead length. Set this to the lead length of the screw in use.

5. The [Step 5: Select the robot tool to use for the end effector] dialog box is displayed. Change the properties according to the table below. Click the [Next] button.

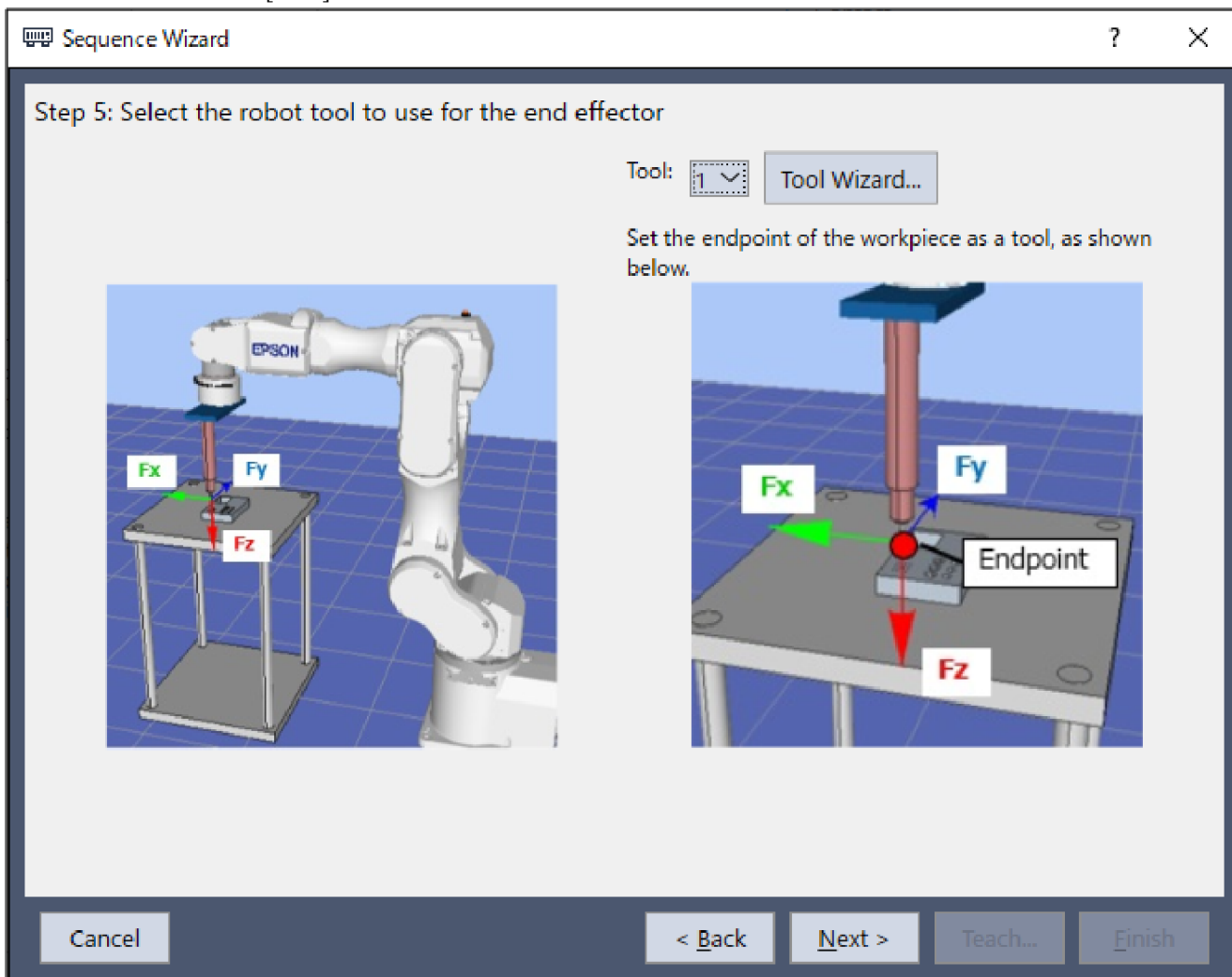

Item	Value	Description
Tool	1	Specify the number set for the tool used in this sequence.

6. The [Step 6: Set tool offsets] dialog box is displayed.

Set tool offset values. These values can be left as the default values and do not need to be changed.

Click the [Next] button.

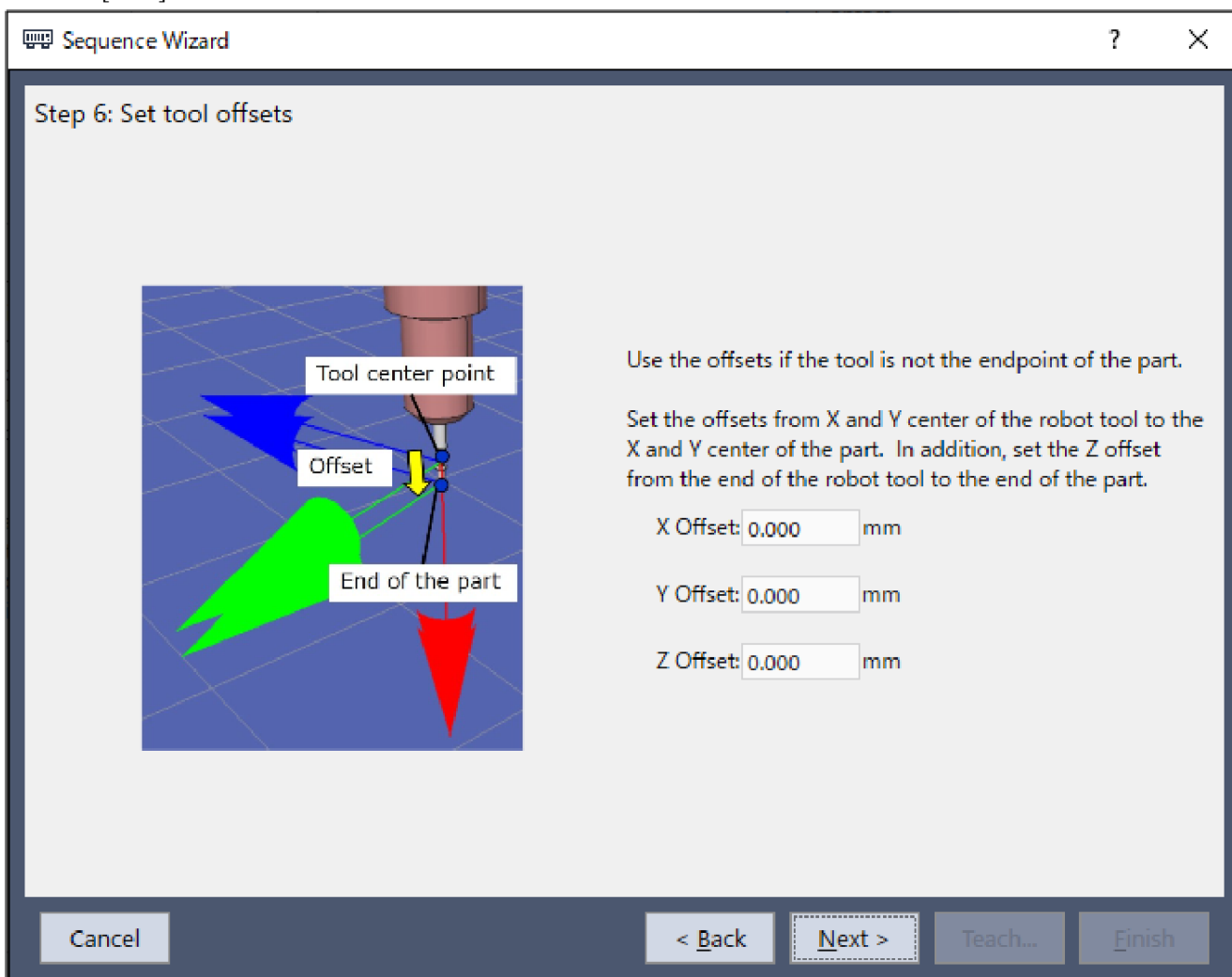

7. The [Step 7: Set the screw tighten operation coordinate system and direction] dialog box is displayed.

As the screw tightening direction is in the +Fz direction in the tool coordinate system, these values can be left as the default

values and do not need to be changed.

Click the [Next] button.

Sequence Wizard

Step 7: Set the screw tighten operation coordinate system and direction

Drive the screw in the tool coordinate system

Drive the screw in the selected base or local coordinate system

Robot local: Base

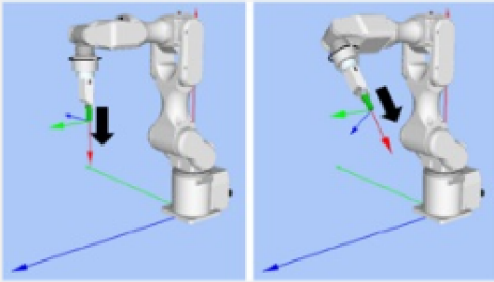

Screw tighten direction: +Fz

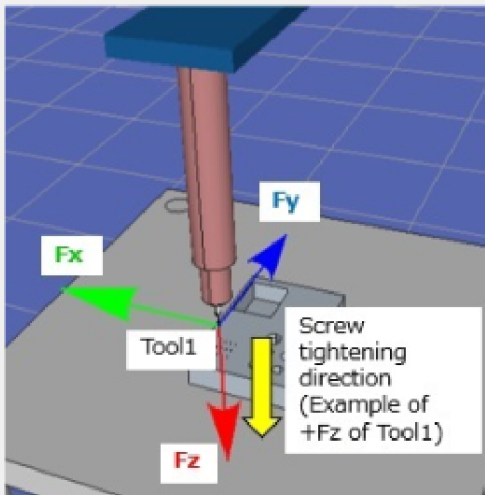

Cancel < Back Next > Teach... Finish

8. The [Step 8: Select whether to enable screw retightening] dialog box is displayed.

Set whether to enable screw retightening. As screw retightening is not performed, this value can be left as the default value and does not need to be changed. Click the [Next] button.

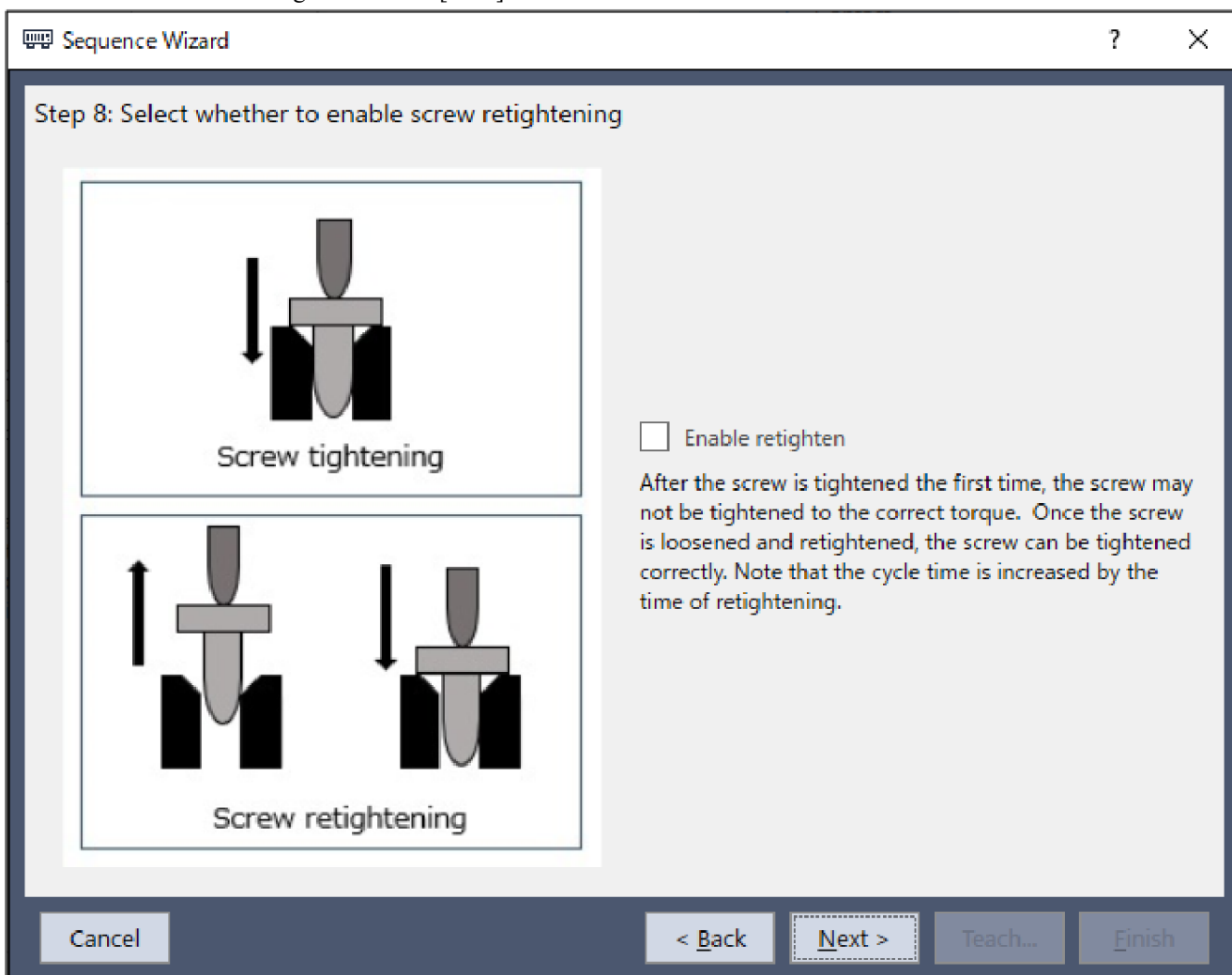

9. The [Step 9: Set the approach distance for the screw driving operation] dialog box is displayed.

Change the properties according to the table below.

Click the [Next] button.

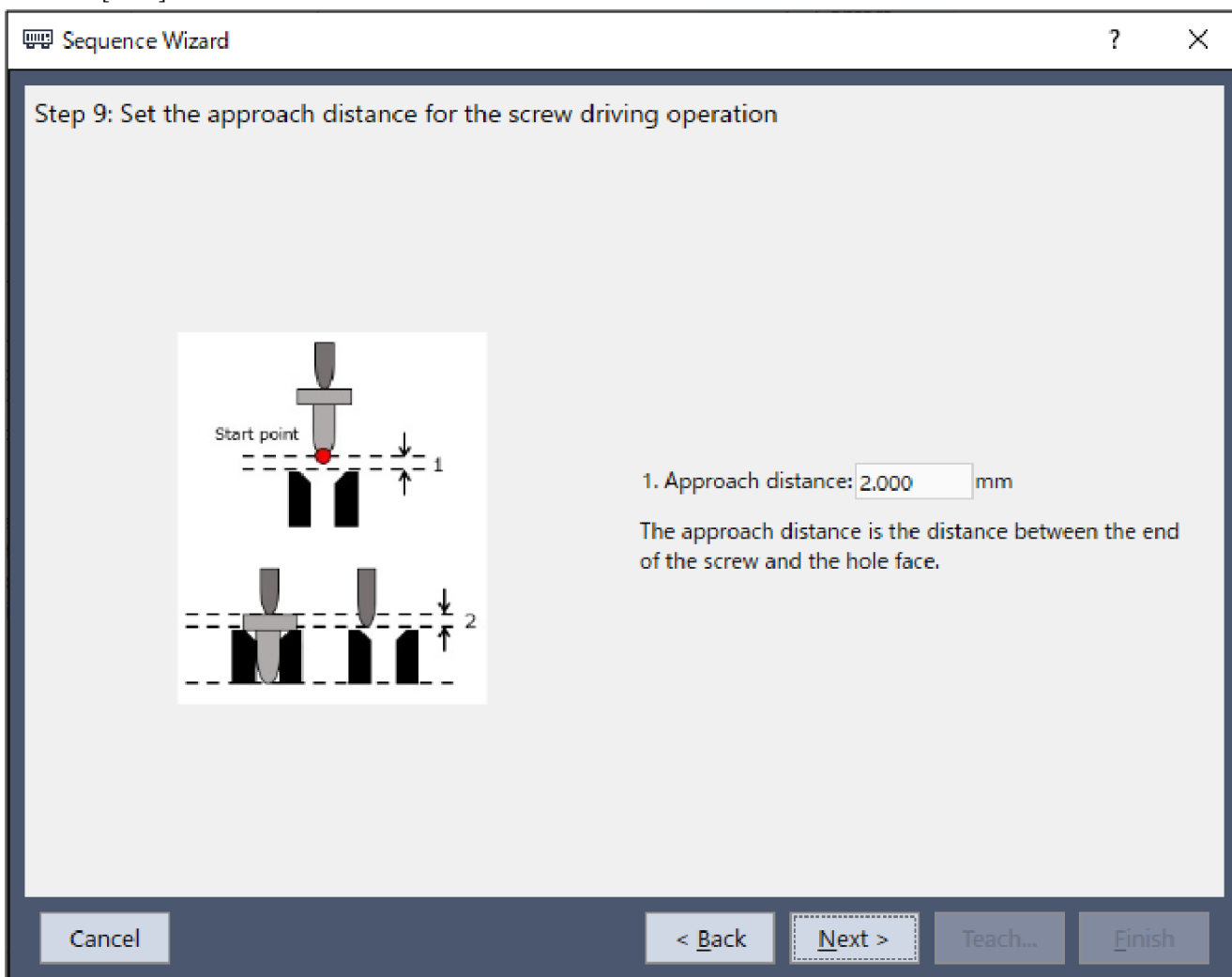

Item	Value	Description
Approach distance	2	Set the distance from the end of the screw to the hole face. Set this to 2 mm.

10. The [Step 10: Set the screw driving force required] dialog box is displayed.

Select [Select force based on screw size].

Change the properties according to the table below.

Click the [Next] button.

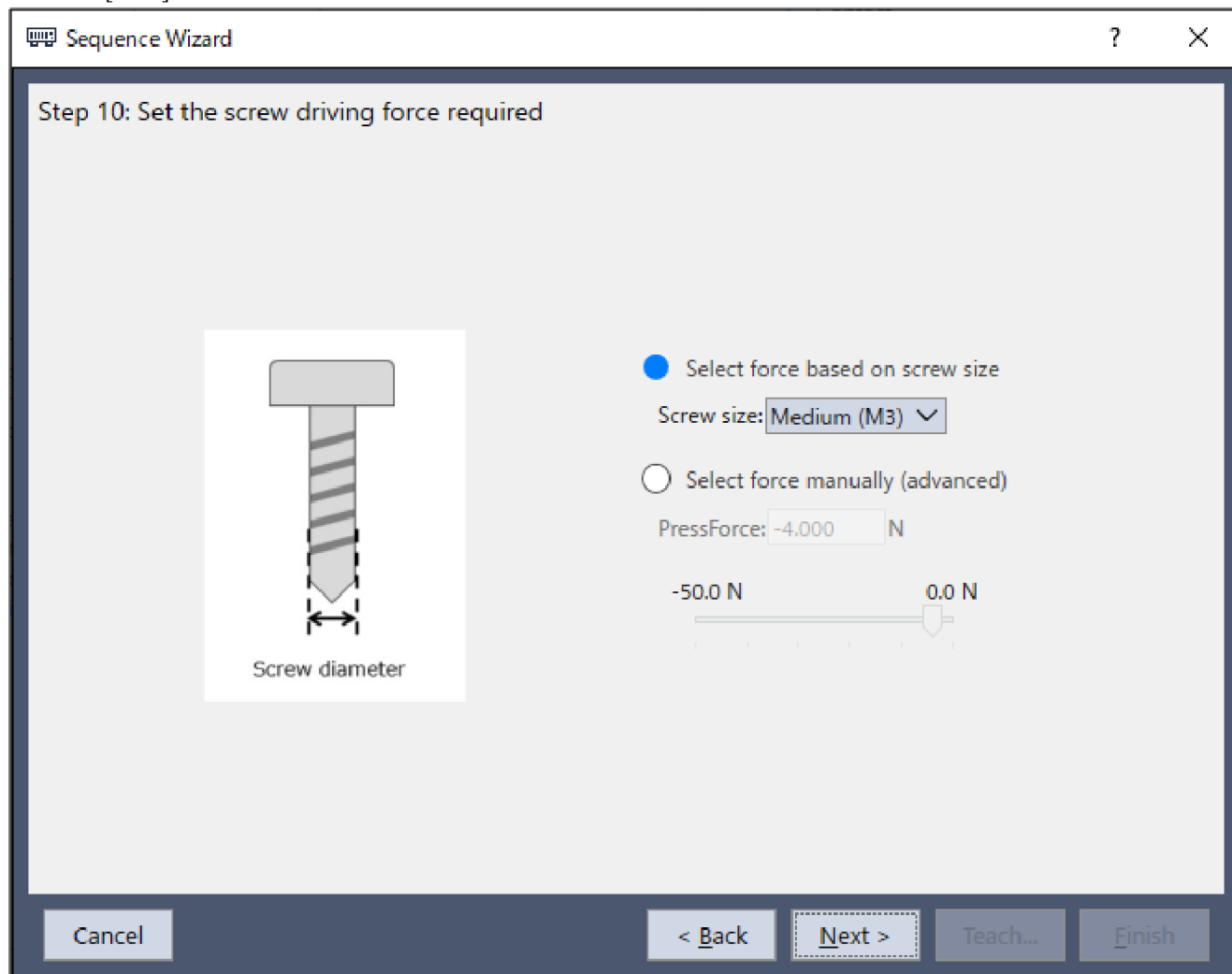

Item	Value	Description
Screw size	Medium (M3)	Set the force applied based on the screw size. When set to Medium (M3), the force applied is Set to -4N.

11. The [Step 11: Set the end condition for screw tightening force] dialog box is displayed.

Change the properties according to the table below.

Click the [Next] button.

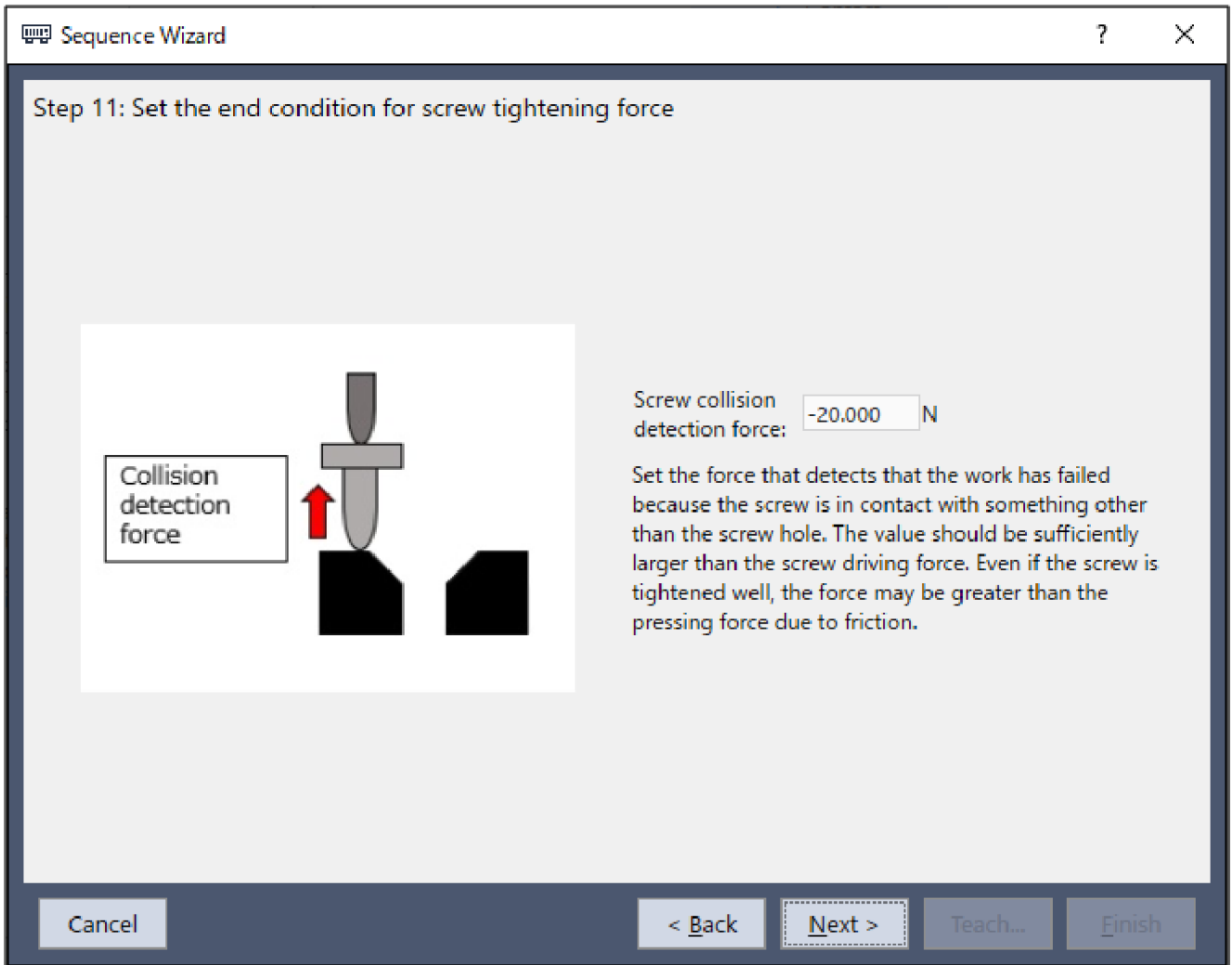

Item	Value	Description
Screw collision detection force	-20	Set the force identified as a collision when the screw comes into contact with an area outside the hole. . Set this to a sufficiently greater value than the screw pressing force. Set this to -20N. Set this to a tolerable value considering the workpiece in use.

- 12. The [Finish] dialog box is displayed.
Click the [Finish] button.

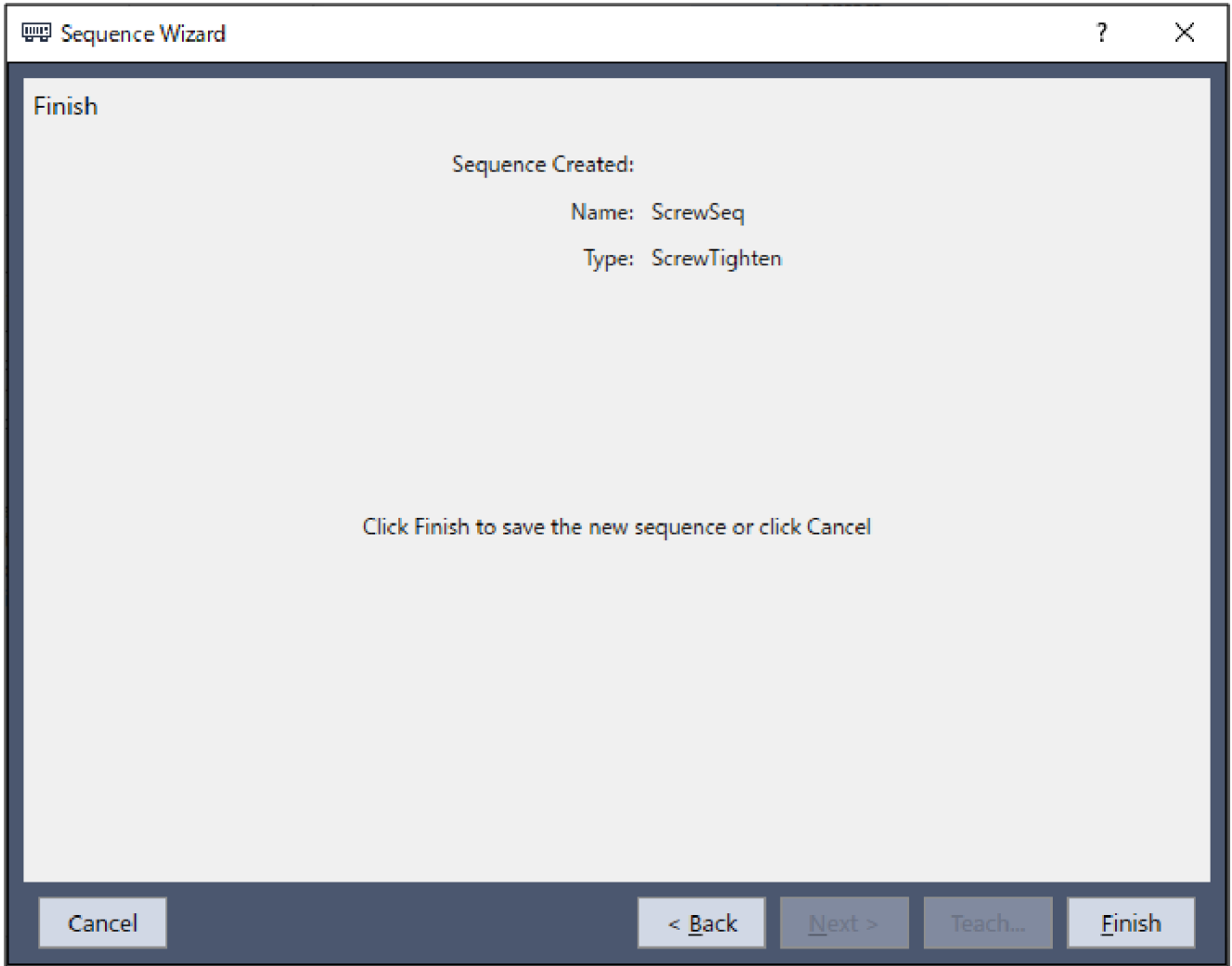

- 13. Check that the [ScrewSeq] sequence has been created.

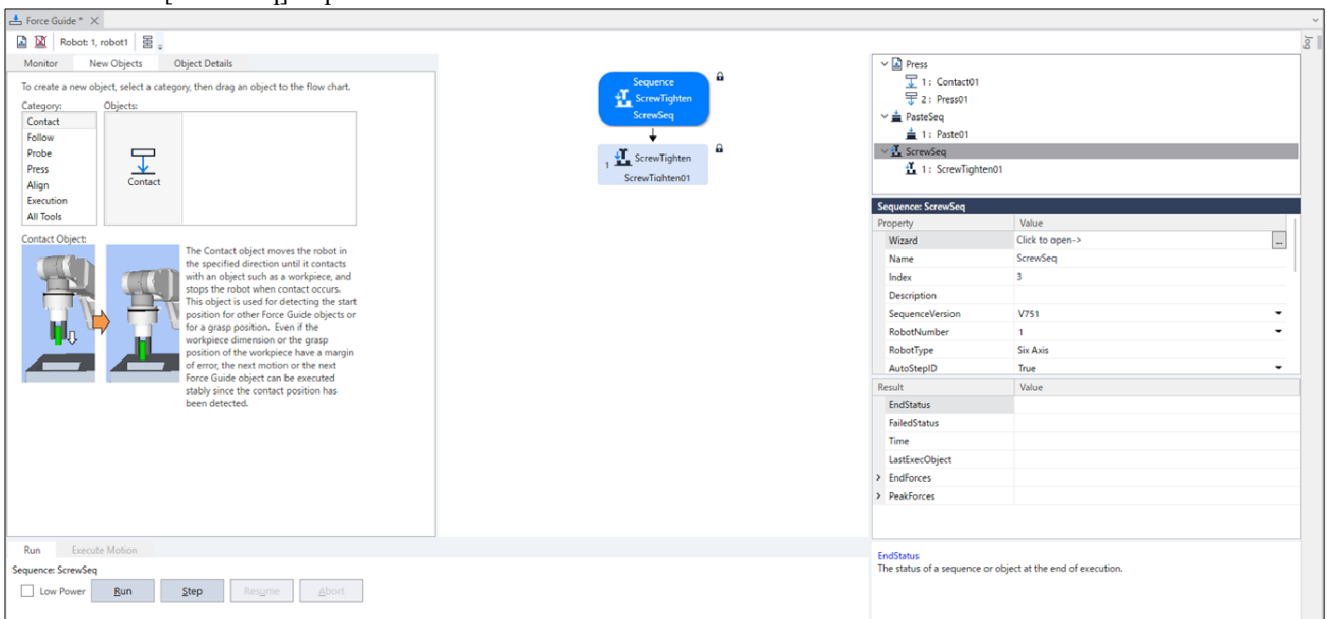

4.6.3.2.4 Setting Confirmation

The following describes how to check whether the settings for screw tightening direction are correct by using a simulator.

1. Click Epson RC+ menu-[Tools]-[Simulator].
The [Simulator] window is displayed.
2. Click the object tree-[Tool].
Place a checkmark in the "No.1"-[Visible] check box. An arrow for "Tool 1" is displayed.
3. Click the object tree-[Force]-[Force Guide]-[ScrewSeq].
Place a checkmark in the "ScrewTighten01"-[Visible] check box.

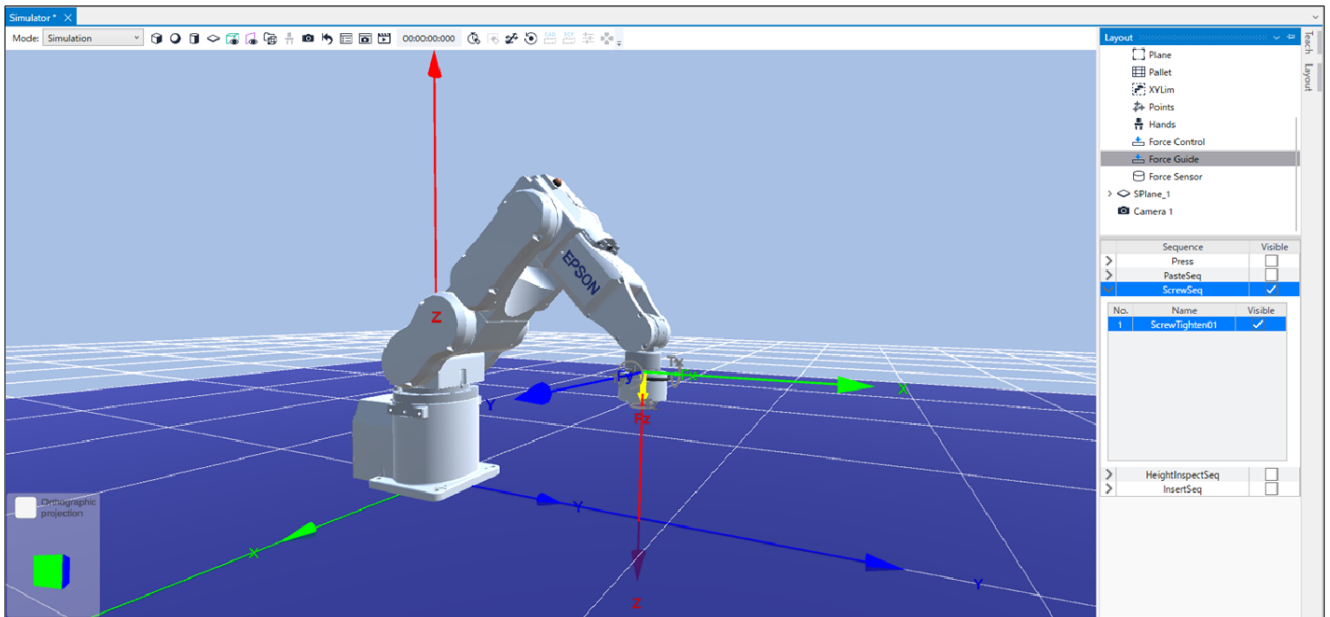

4. Confirm that the yellow arrow direction is the same as the screw tightening direction.

4.6.3.2.5 Motion by Force Guidance Function

The following describes how to run the created ScrewTighten sequence by Epson RC+.

1. Open the [Force Guide] window.
2. Select the [Jog] tab.
3. Click the [POWER HIGH] button.
If the robot might break the workpiece, operate in "Low Power Mode".
4. Click the [Execute] button.
Program is compiled and transmitted to the Robot Controller.
If the setting is not correct, an error occurs. Check the settings so far and follow the error message to modify the parameters.

5. When the operation is performed properly,  is displayed on the upper left of the flowchart and the screw tightening is completed.

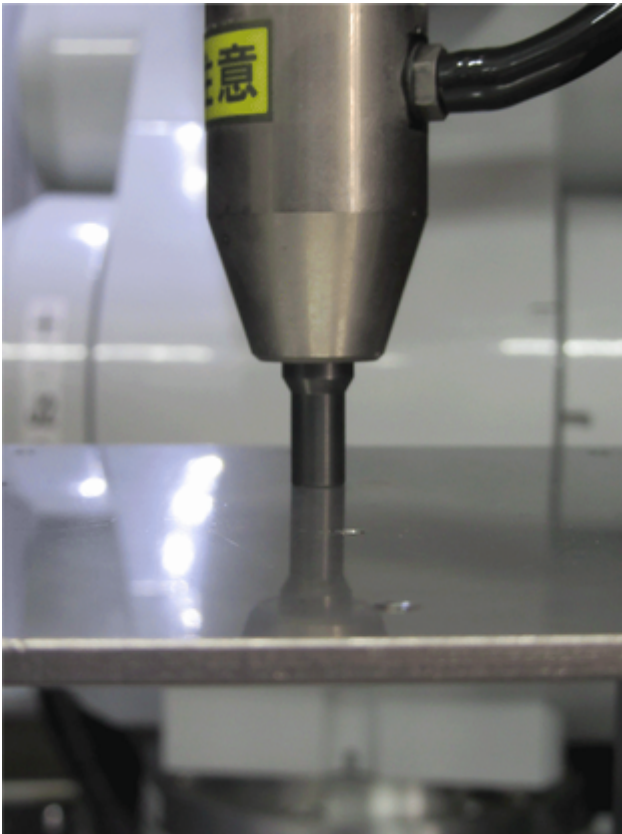
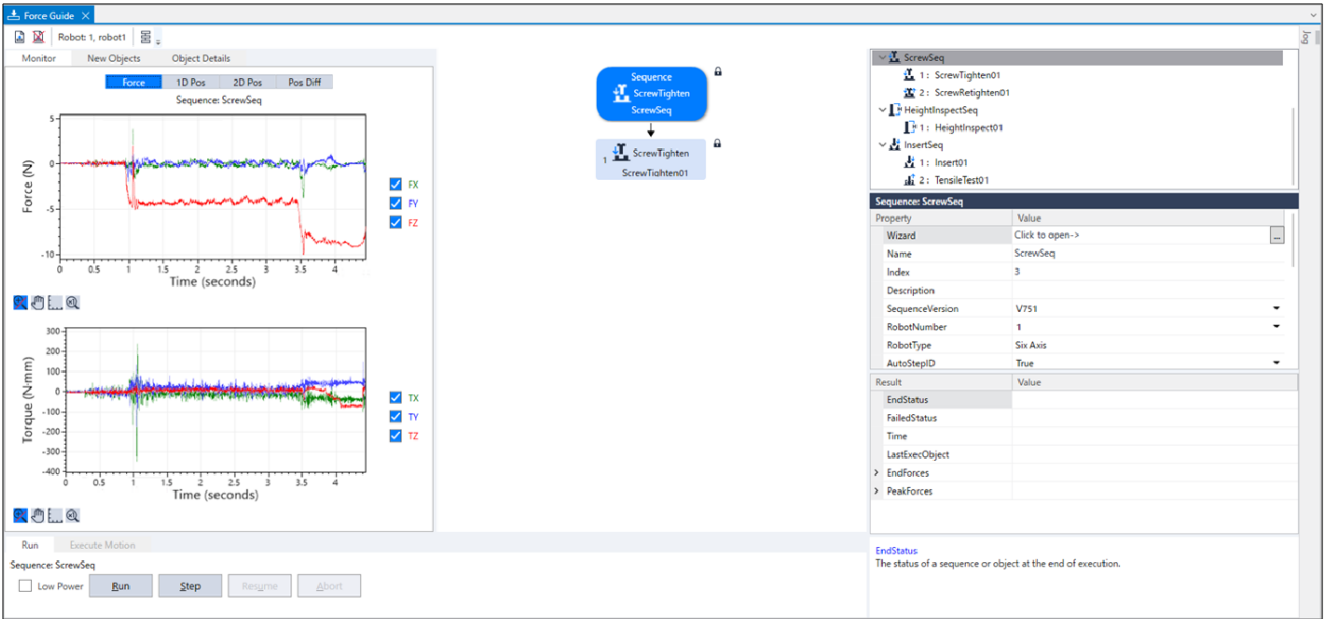

4.6.3.2.6 Return to the Non-Contact State

After completing ScrewTighten sequence, force continues to be applied to between the robot and the workpiece. To prevent the robot and the end effector from malfunction or damages, after the operation ends, make sure that no force is applied to the object. If it is obvious that no force is applied to the object, you can omit this step.

Steps to return to a non-contact state are as follows:

- Click Epson RC+ menu-[Tools]-[Robot Manager]-[Jog & Teach] panel-[Jog] group and perform jog motion manually to move the robot away from the object.

- Click Epson RC+ menu-[Tools]-[Robot Manager]-[Jog & Teach] panel-[Execute Motion] tab and move the robot away from the object.
- Execute Move command on [Command Window] and move the robot away from the object.
- Add SPELFunc object after ScrewTighten object, and automatically move the robot away from the object at the end of the force guide sequence.

The following describes how to return to non-contact state by clicking [Robot Manager]-[Jog & Teach]-[Execute Motion] tab.

1. Display the [Robot Manager] dialog box.
2. Click the [Jog & Teach] tab.
3. Select the [Execute Motion] tab.
4. Select "Move" in [Command].
5. Select "P1" in [Destination].
6. Click the [Execute] button.

The robot moves to the start point: P1. Now, it is the non-contact state.

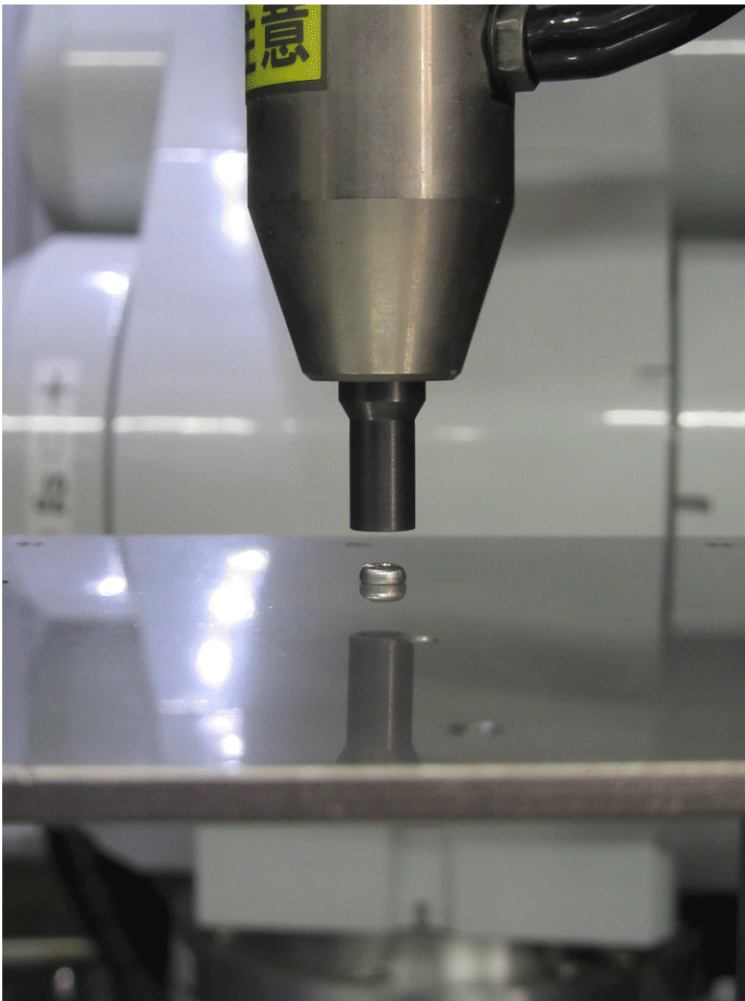

4.6.3.2.7 Motion Analysis by Monitor

The following describes how to use Epson RC+ to check the operation results of a force guide sequence.

1. Open the [Force Guide] window.
2. Click the sequence flow of [ScrewSeq].

3. Select the [Monitor] tab. Select the [Force] tab.

Force and position during the [ScrewSeq] sequence execution are displayed in the graph.

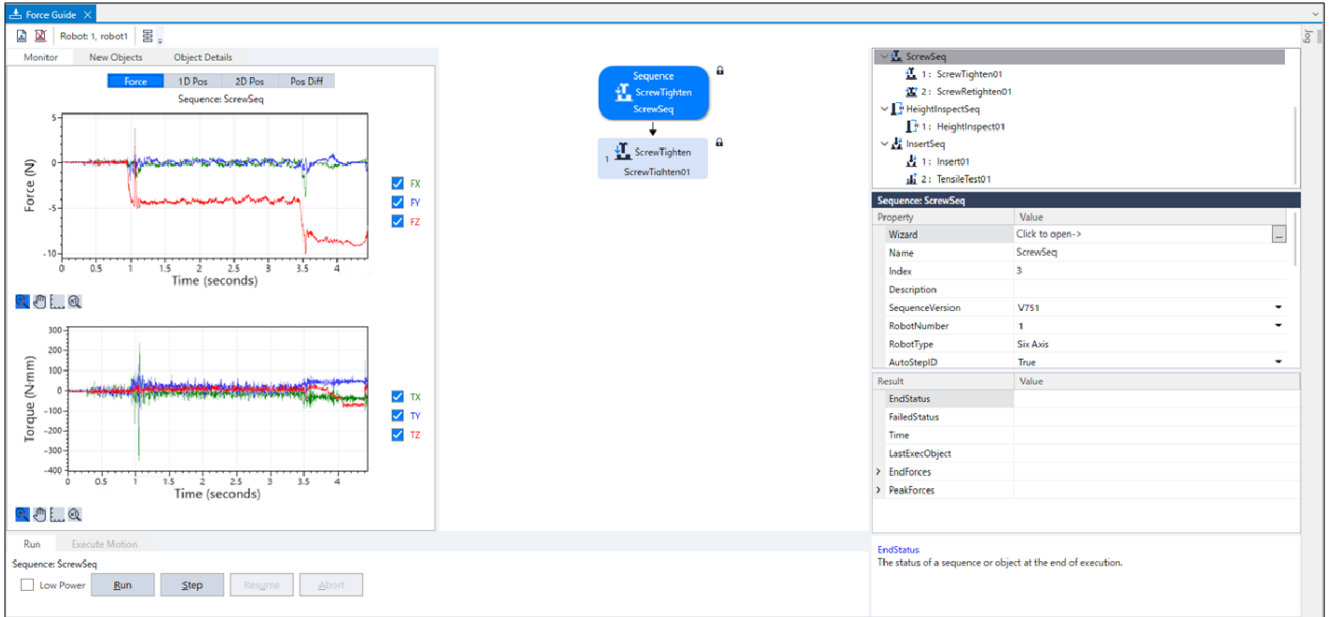

4. Select the [1D Pos] tab.

Graph for analysis is displayed. (horizontal axis: Time, vertical axis: Position)

As you can see by looking the Position Z graph, CurZ (current position) is lowered by about 7 mm. It indicates that the robot moves in the screw tightening direction by 2mm of the approach distance and by 5mm of the screw length.

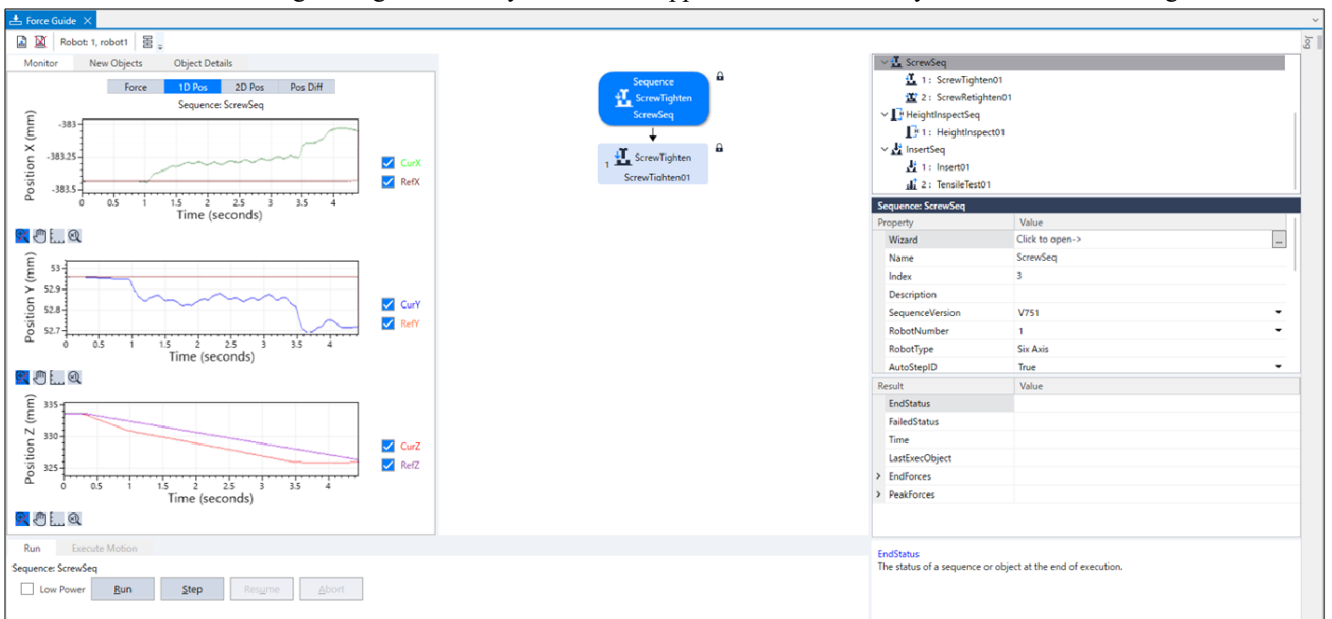

5. Select the [2D Pos] tab.

Graph for analysis is displayed. (horizontal axis, vertical axis: Position)

You can see what you have checked on the [1D Pos] tab as a graph projected on each plane.
 Be careful of the scale difference of horizontal axis and vertical axis when checking the graphs.

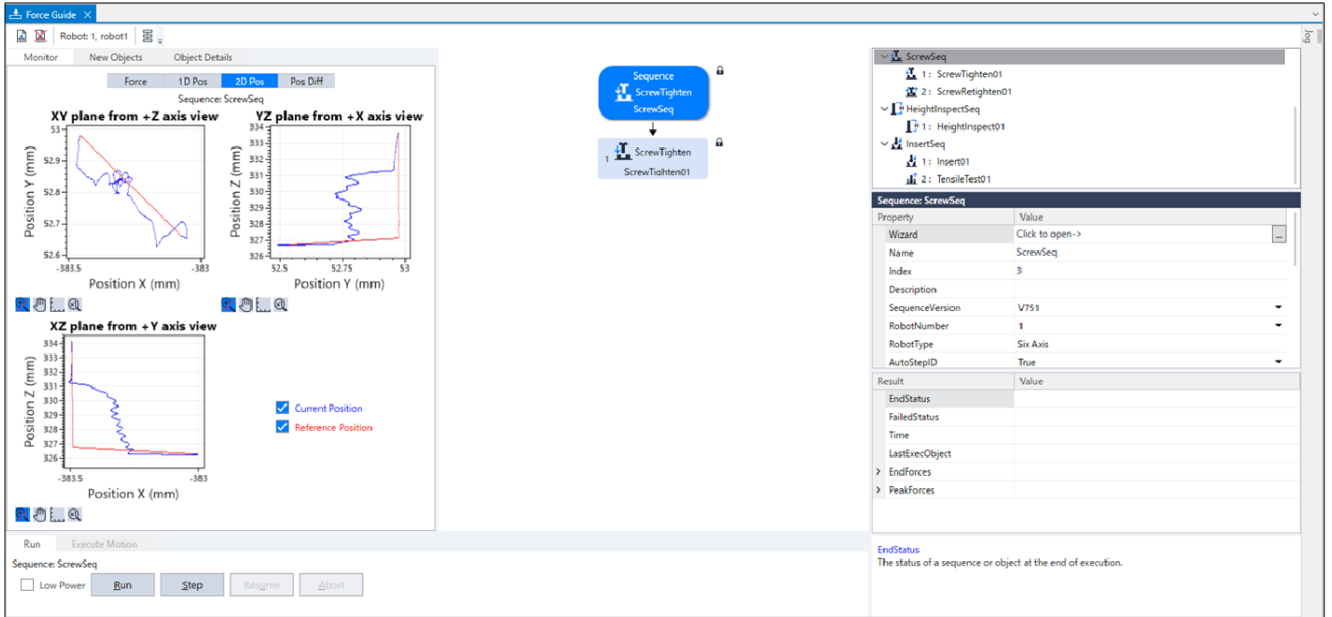

6. Select the [Pos Diff] tab.
 Record shifts by force control as relative position changes.
 It is different from the graph on the [1D Pos] tab.

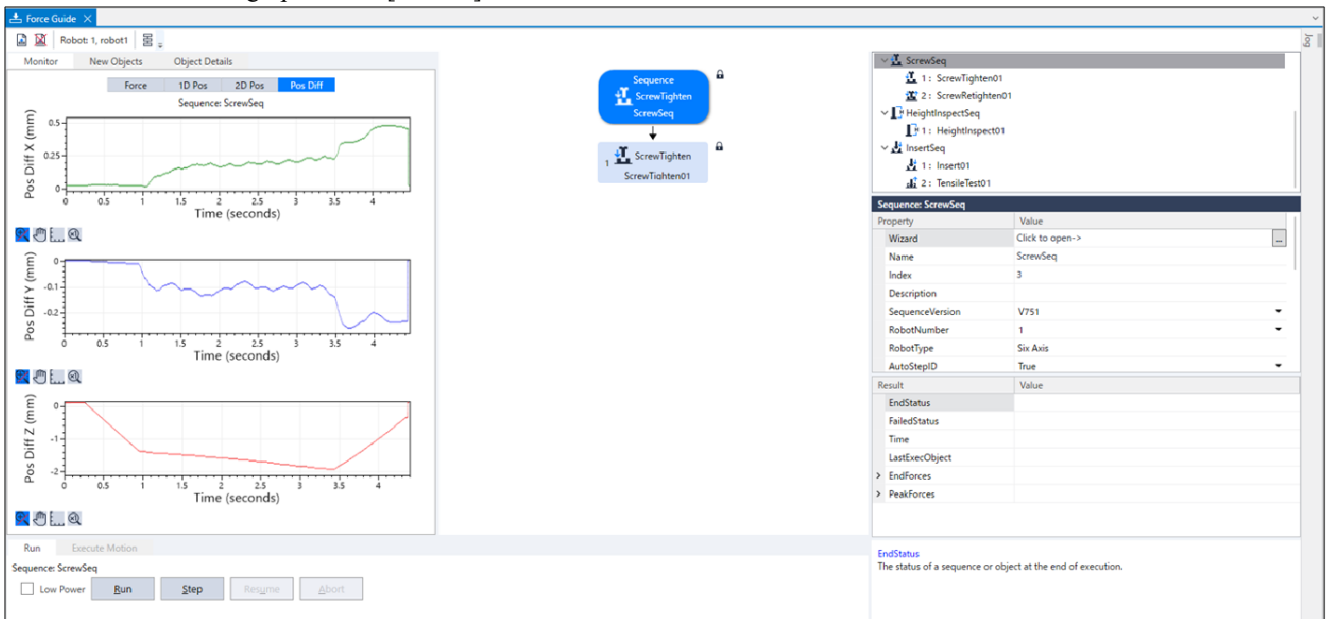

7. Change the unit of the graph and check the changes of force or positions.

If it is not tightened correctly, the setting may not be correct. Refer to the following and check the procedures of the tutorial.

- Whether a pressing force direction is correct
- Whether the start point is largely moved from a hole
- Whether the setting of the approach distance is correct
- Whether the setting of the driver rotation speed, screw length, and lead length are correct

4.6.3.2.8 Advanced Tasks

Let's do the following advanced tasks.

The default end condition for the screw tighten sequence position is whether the position of the object from the start of the screw tighten sequence is within the "approach distance + screw length ± 1 mm".

Under this condition, the system may erroneously detect that the screw tightening process has ended successfully even if the screw gets caught and is improperly tightened.

To counter this, set stricter finishing position conditions, and add a sequence to loosen and retighten the screw if the completion conditions are not met.

1. Change the [ScrewTighten01] property as follows.

Item	Value	Description
DistCheckTol	0.1	Specify the success condition range for distance moved from the motion start point. Set the success condition range to the "approach distance + screw length ± 0.1 mm".

2. In the flowchart, right click [Sequence ScrewTighten], and then click [Sequence Wizard].

The screw tighten sequence wizard will be displayed.

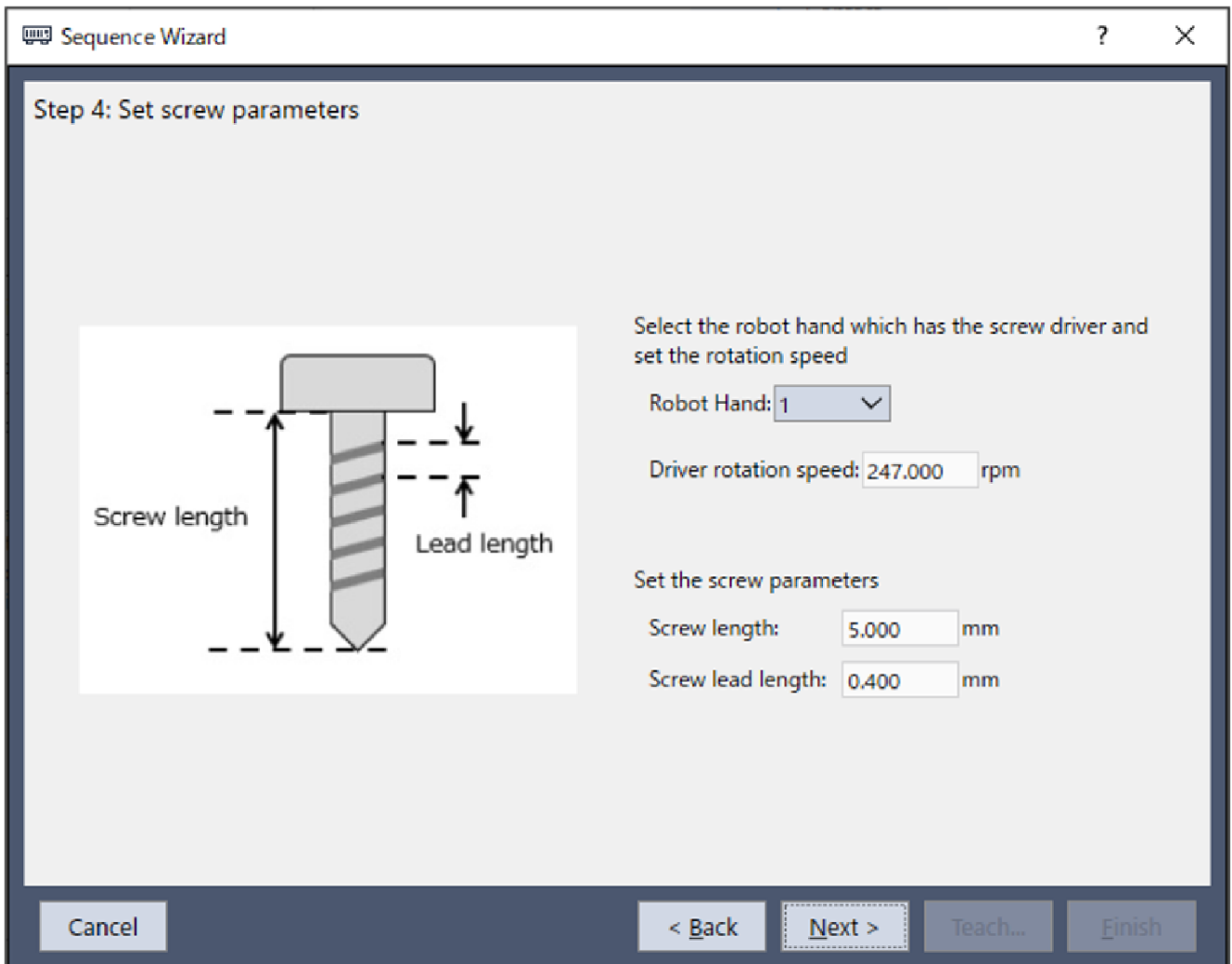

3. Without changing any settings, click the [Next] button until the [Step 8: Select whether to enable screw retightening] dialog box is displayed. Select the [Enable retighten] checkbox.

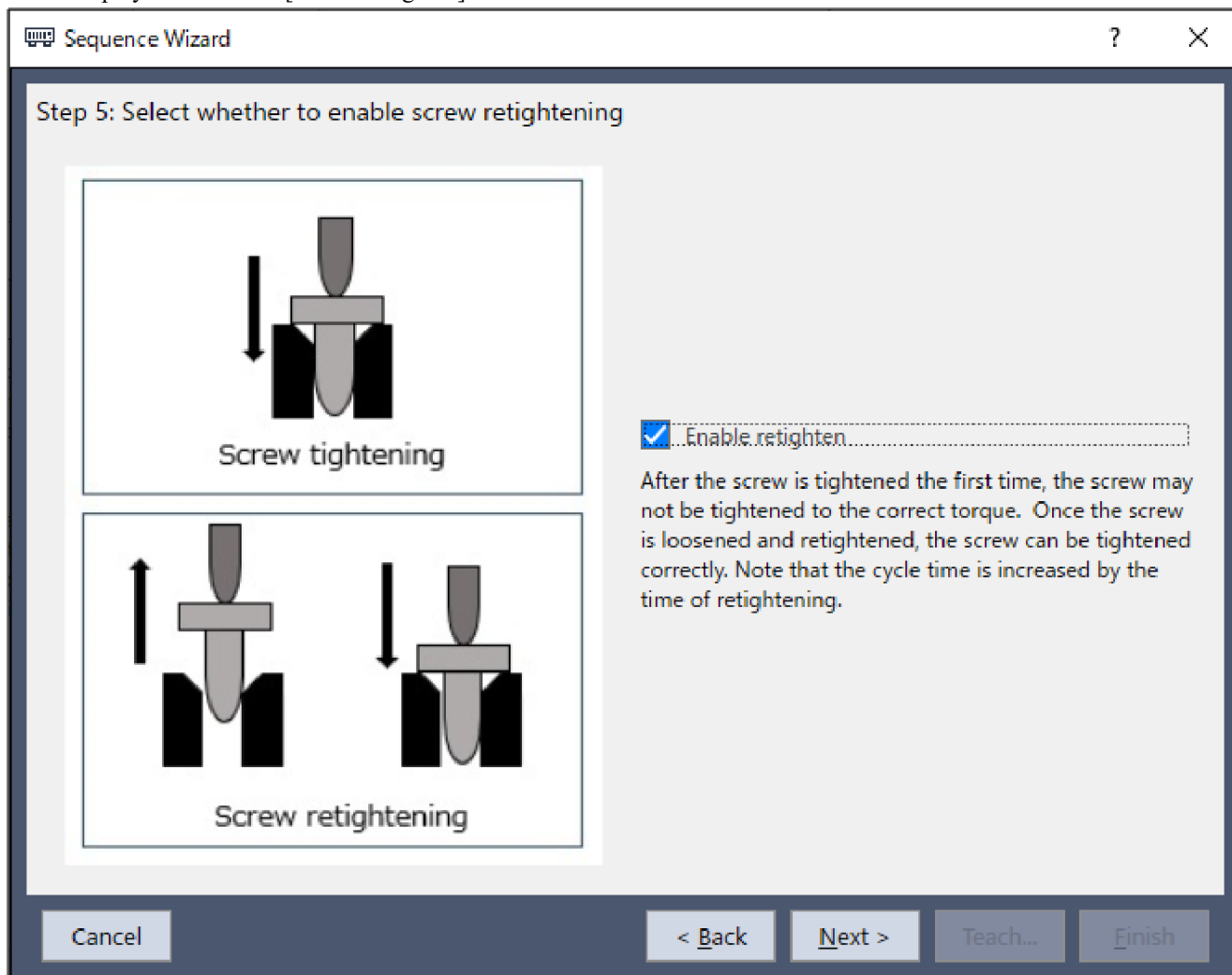

- Click the [Next] button until the [Step 9: Configure screw retightening operation] dialog box is displayed.
Change the properties according to the table below.
Click the [Next] button.

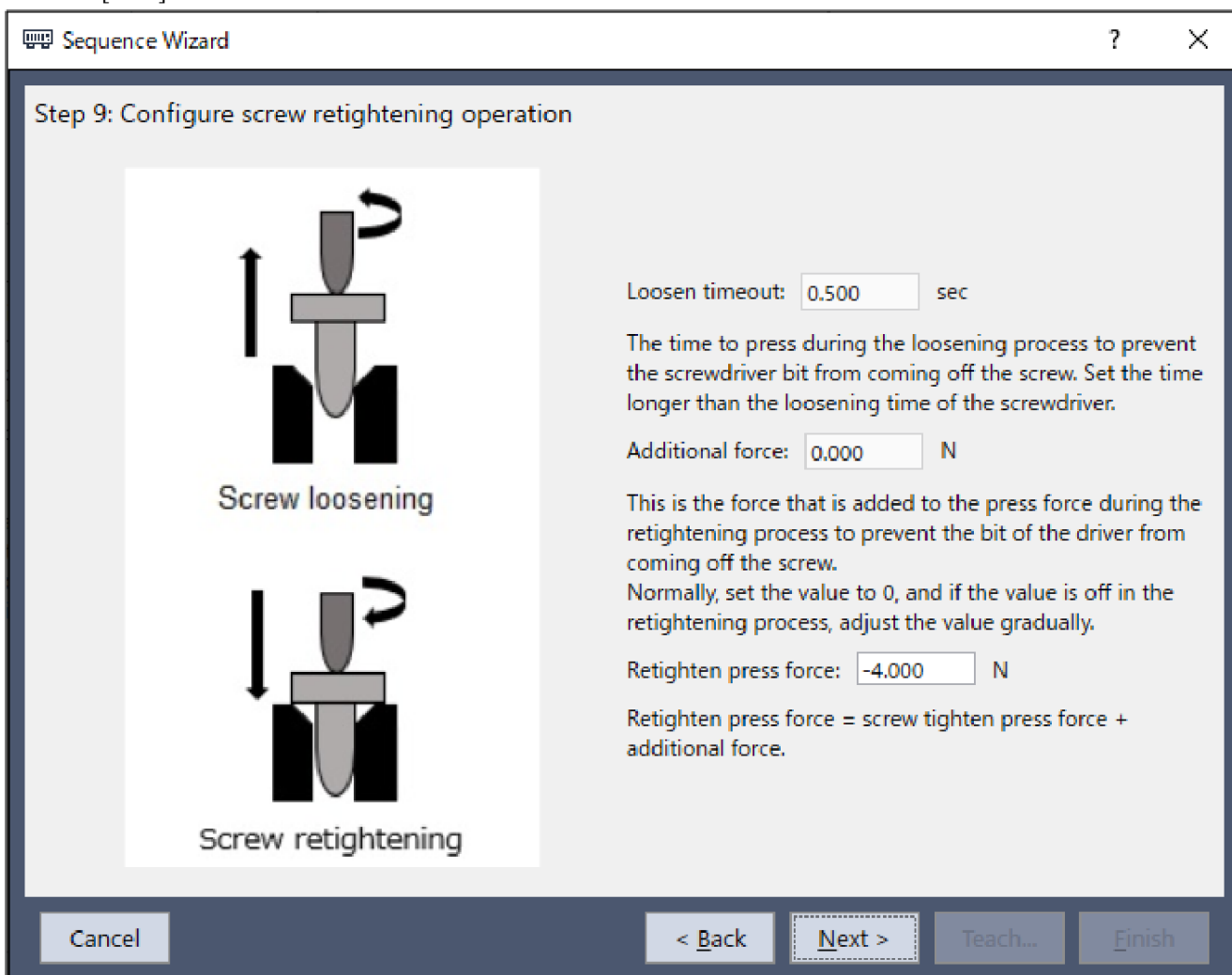

Item	Value	Description
Loosen timeout	0.5	Set the screw loosening duration. Set this to 0.5 seconds.
Additional force	0	Set the additional screw pressing force when retightening. Set this to 0 N.

- 5. The [Step 10: Change Summary] dialog box is displayed.
Click the [Finish] button.

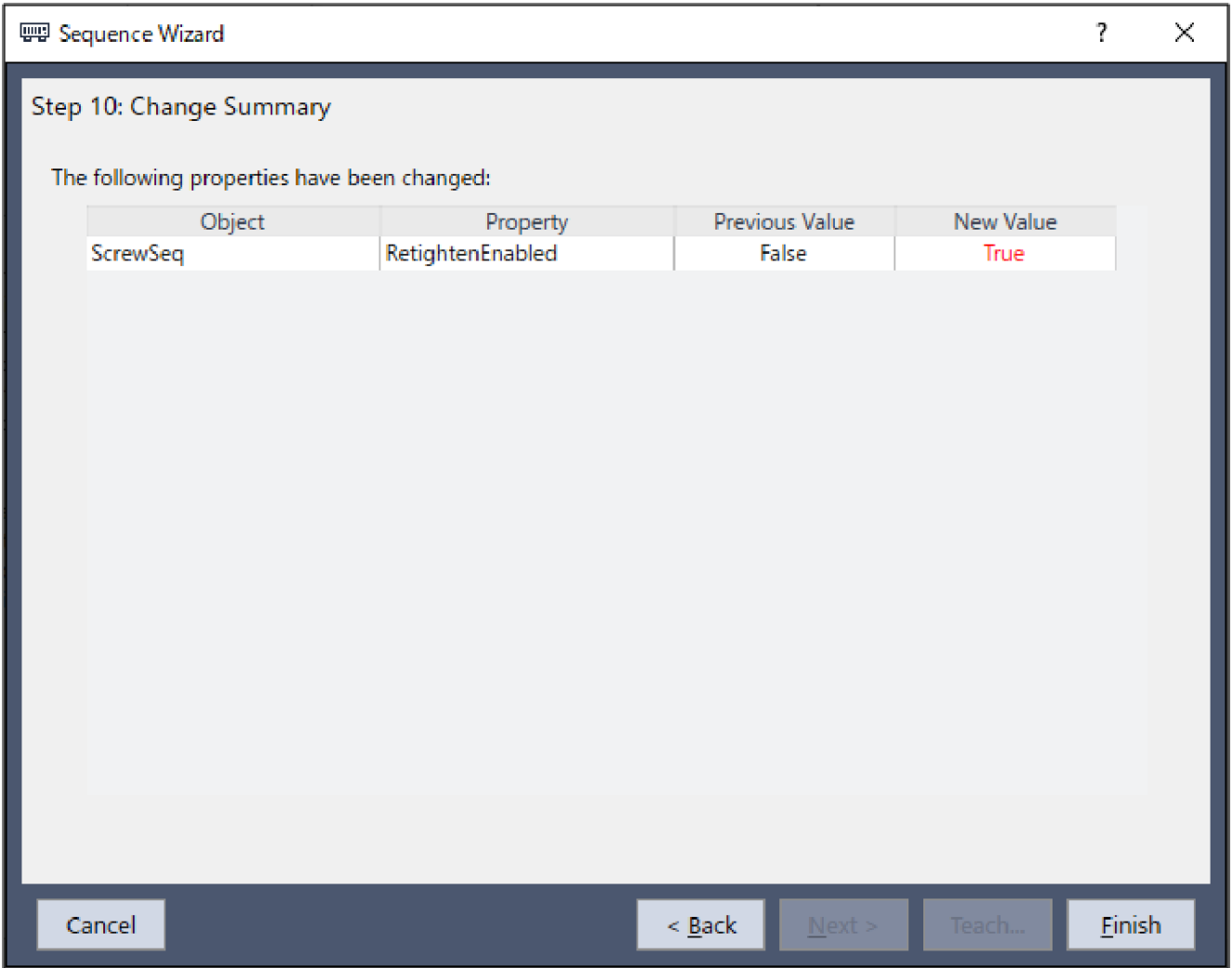

- 6. Check that the [ScrewRetighten01] object has been added.

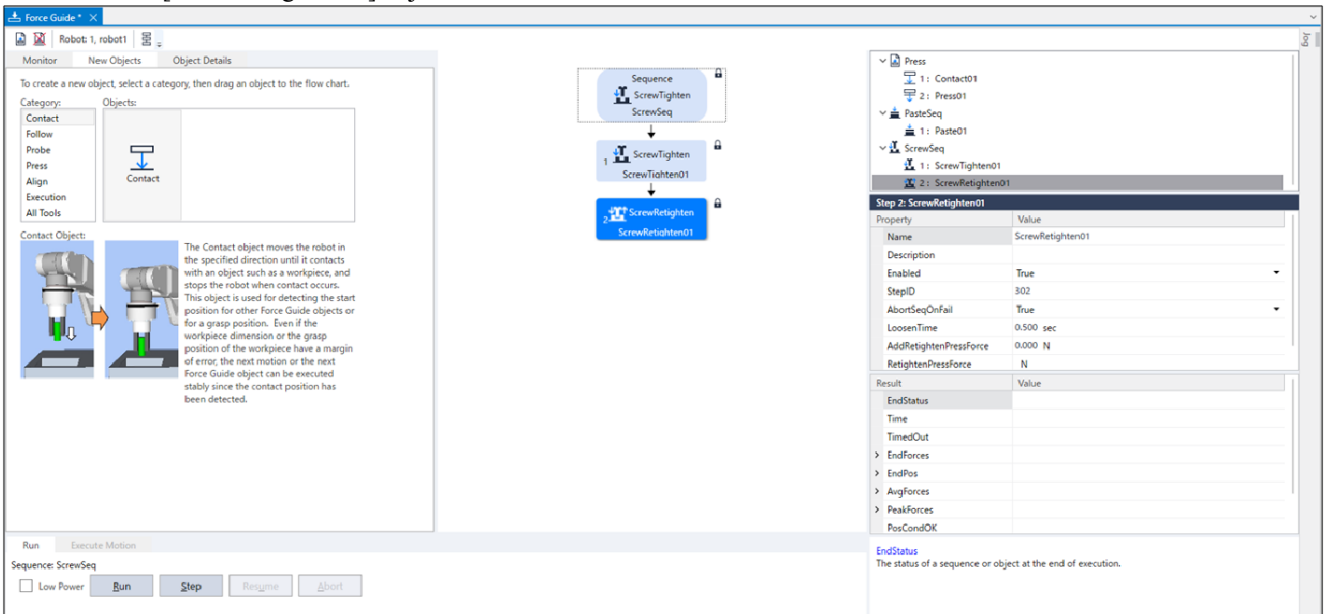

- 7. Now try running the sequence you have created.

This ends the screw tighten sequence tutorial.

4.6.3.3 HeightInspect Sequence

The following describes how to perform a height inspection using the HeightInspect sequence of the system force guide sequence.

This tutorial describes the inspection method for inspecting the position when the robot contacted to the object to be inspected. Prepare a workpiece by yourself. Incorrect settings may result in damage of the workpieces. Prepare workpieces that can be damaged, and proceed with this tutorial.

Set the arrangement and inspecting direction of a workpiece in the same way as the image below.



⚠ CAUTION

The parameters described in the example on the following pages are reference values.

This tutorial uses relatively stable parameters, but depending on the operating environment, the operation may not be successful or the motion may be vibratory. Note that adjusting the parameters may be required. note that Slow, stable parameters are used for convenience of explanation. For high-speed operation, adjusting the parameters is required.

4.6.3.3.1 Confirmation of Tool Setting

The following describes tool setting procedures.

In the HeightInspect sequence, you need to consider the behavior of the actual inspecting direction and the current tool settings.

1. Use a caliper to measure the distance from the J6 flange plane to the contact point of the workpiece that is attached when you inspect the height.
Execute the following in [Command Window].
In "Length", enter the value measured in the procedure (1).

```
> Tlset 1,XY(0,0,Length,0,0,0)
```

2. Click Epson RC+ menu-[Tools]-[Simulator]. The [Simulator] window is displayed.
3. Select the object tree-[Manipulator Name]-[Tool].
4. Place a checkmark in "No.1"-[Visible] check box.
5. To confirm that the tool setting is correct, compare the display of the [Simulator] window and the orientation of the actual robot.

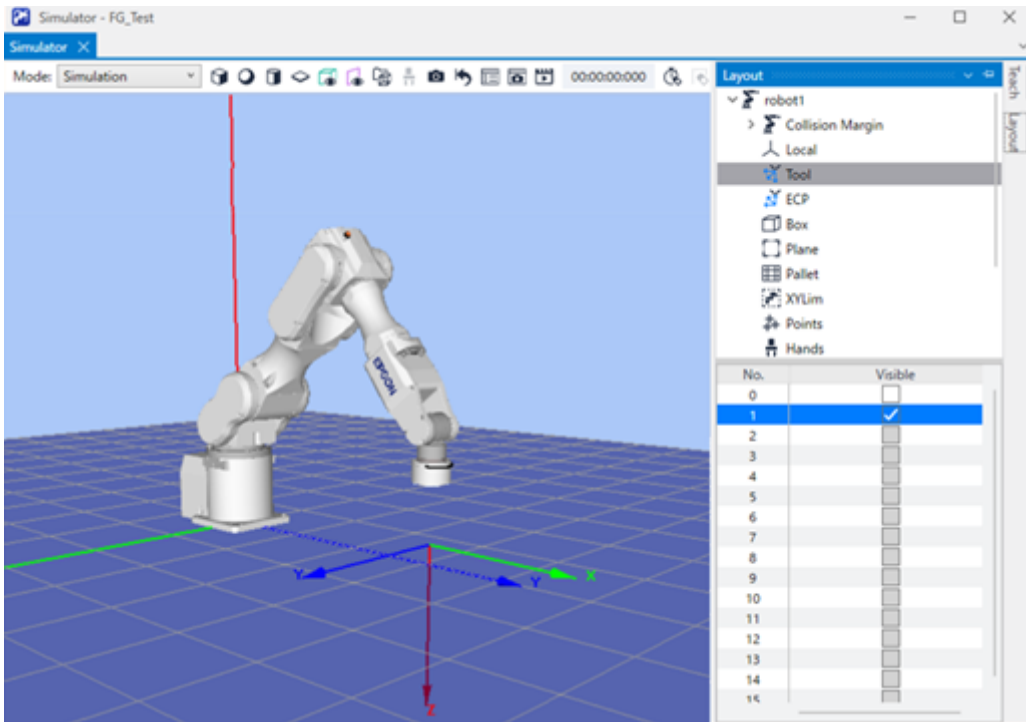

According to the display of the [Simulator] window, you will see that height inspection is performed to +Z direction of the tool.

4.6.3.3.2 Position Teaching

The following describes how to teach a sequence start position of HeightInspect sequence.

1. Click Epson RC+ menu-[Tools]-[Robot Manager].
The [Robot Manager] dialog box appears.
2. Select [Jog & Teach] and open the panel.

3. Select "1" on [Tool].

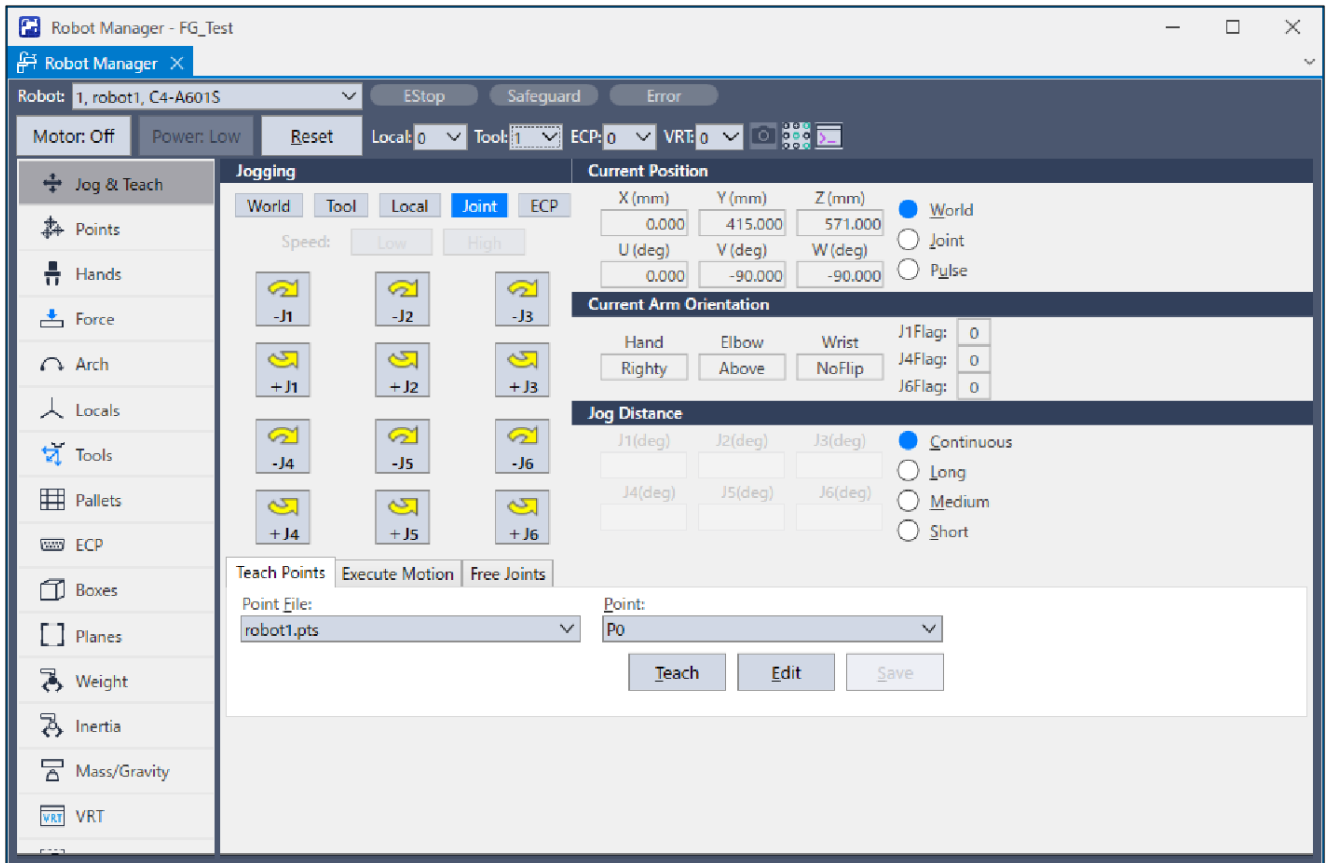

- Click the Jog button to move the robot to about 3mm above the contact point with the object to be inspected.

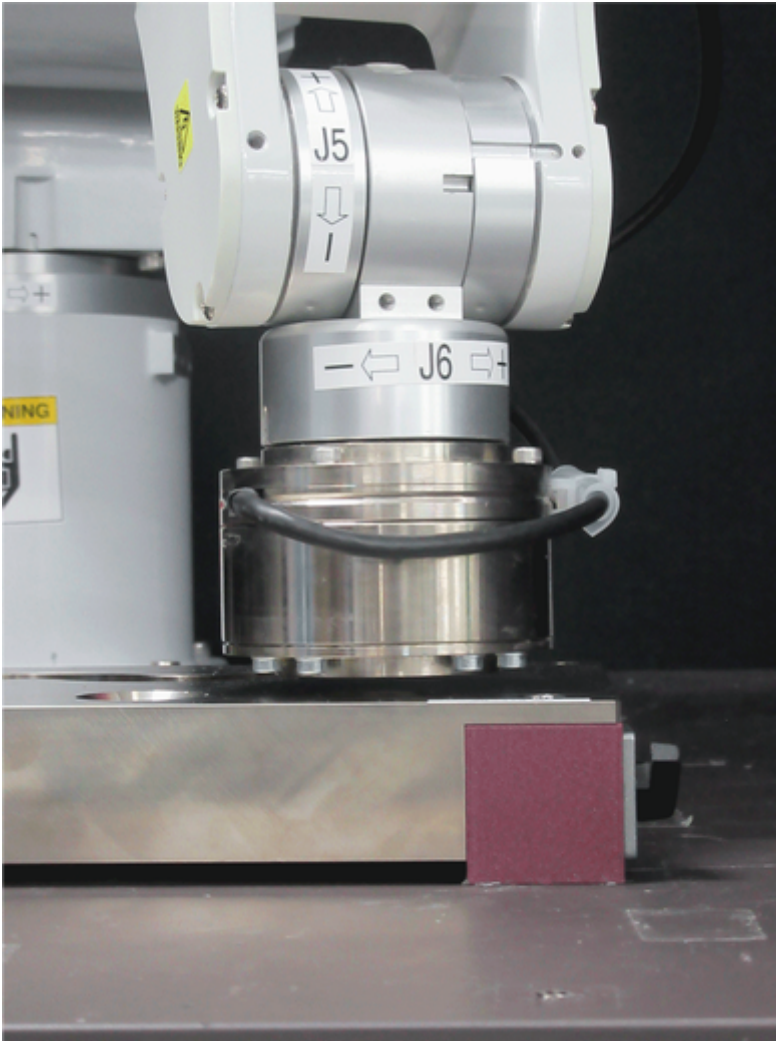

Execute the following command in the command window if necessary.

```
> Go Align (Here)
```

By executing the above command, the robot will be a parallel orientation against the Base coordinate system based on the current position. The robot can move more easily when it and the contact point are facing one another. For details, refer to the following manual: Epson RC+ SPEL+ Language Reference Align Function

- Select "P1" in the [Point] dropdown.

- Click the [Teach] button.

The following message is displayed.

Confirm the message and click the [Yes] button.

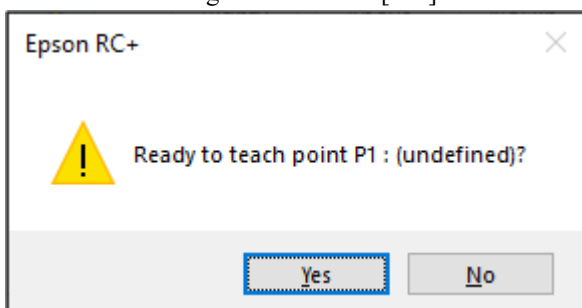

7. The [New Point Information] dialog box is displayed.
Enter "HeightInspectStart" to [Point Label] and click the [OK] button.

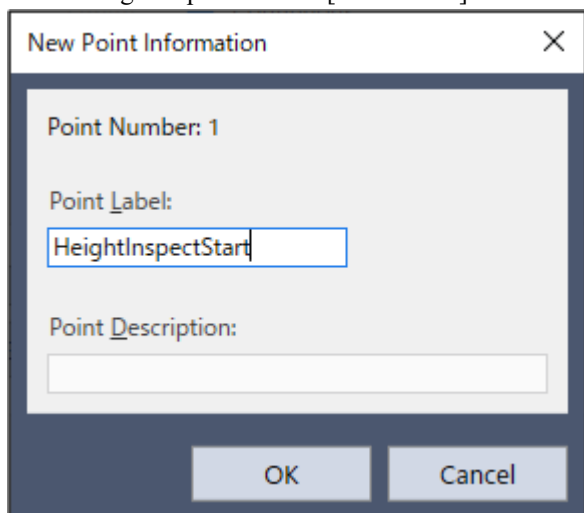

8. Click Epson RC+ menu-[File]-[Save All].
Set contents will be saved in the file.

4.6.3.3 Sequence wizard

The following describes how to create HeightInspect sequence of the system force guide sequences.

1. Enter "HeightInspectSeq" in the [Enter name for new sequence] box.
Click the [Next] button.

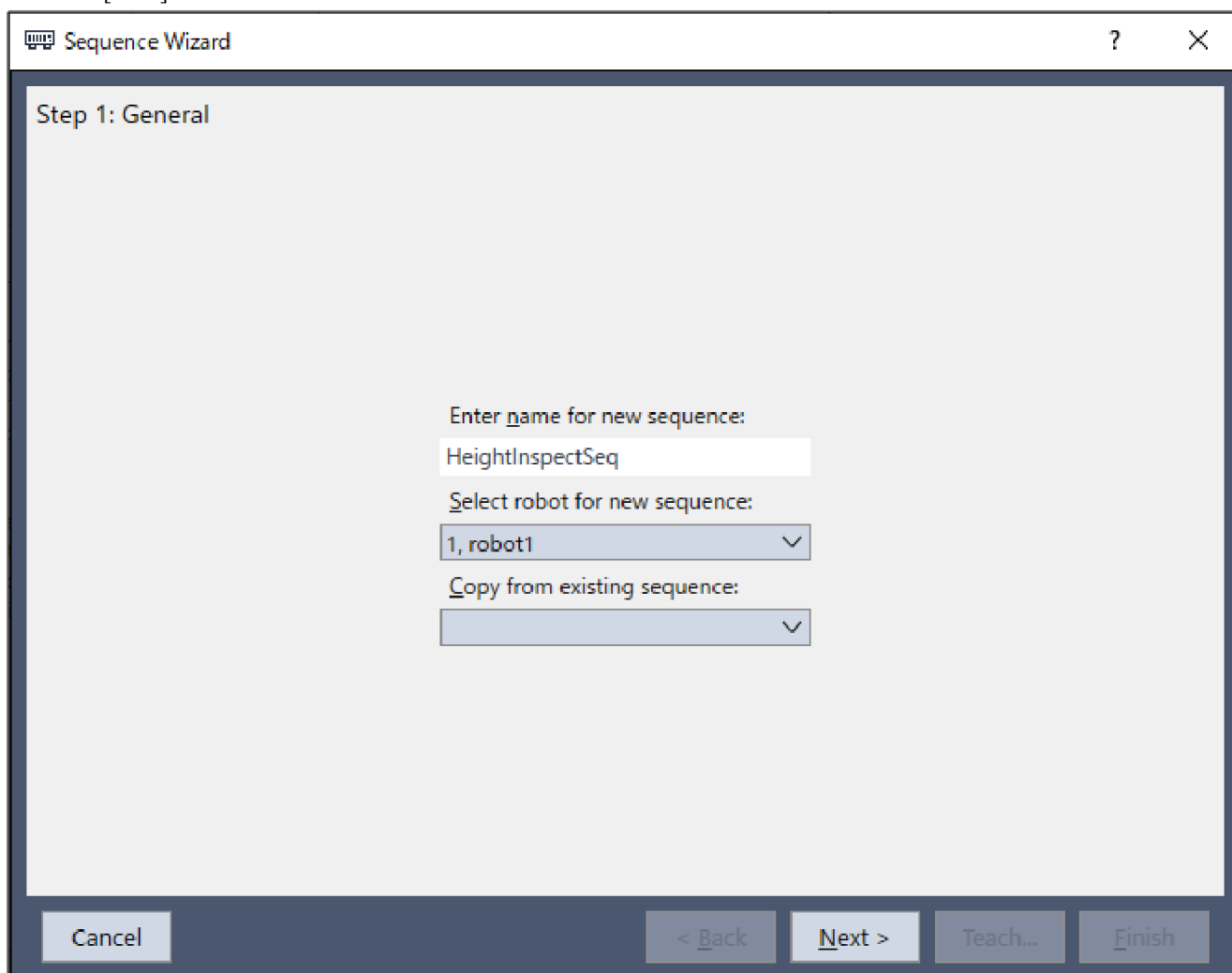

2. The [Step 2: Select sequence type] dialog box is displayed.
Select [System]. Click the [Next] button.

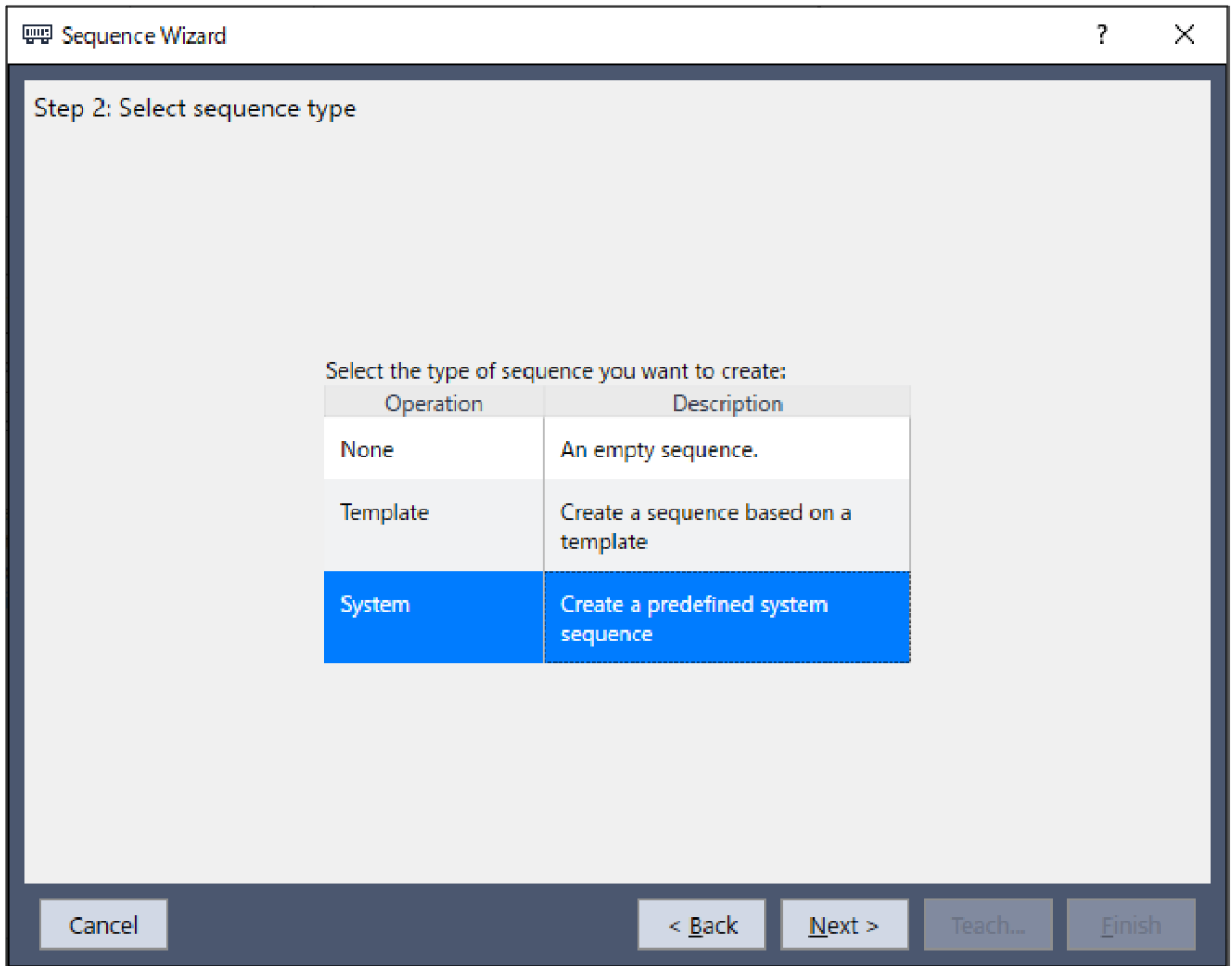

3. The [Step 3: Select system sequence] dialog box is displayed.

Select [Inspect height].

Click the [Next] button.

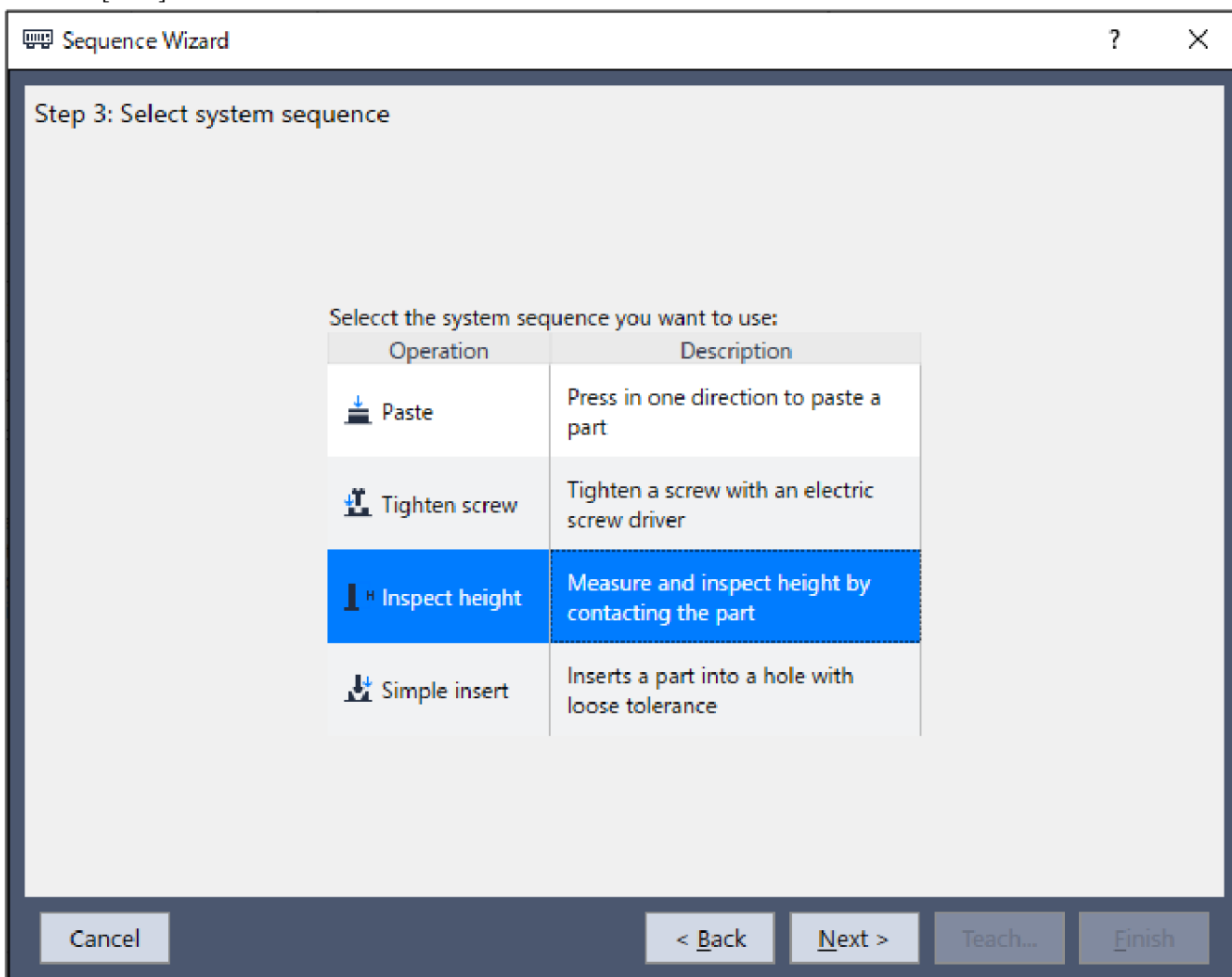

4. The [Step 4: Select the robot tool to use for the end effector] dialog box is displayed.

Change the properties according to the table below.

Click the [Next] button.

Sequence Wizard
?
×

Step 4: Select the robot tool to use for the end effector

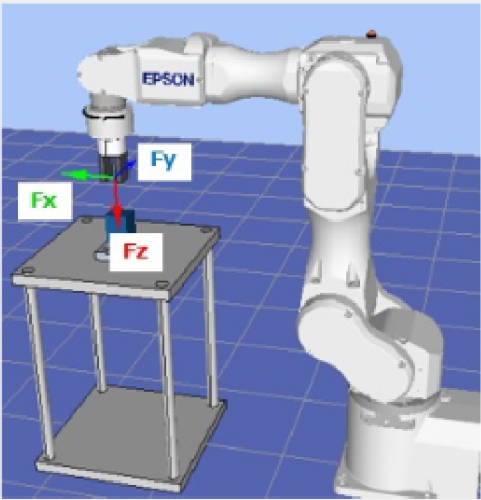

Tool: Tool Wizard...

Set the endpoint of the workpiece as a tool, as shown below.

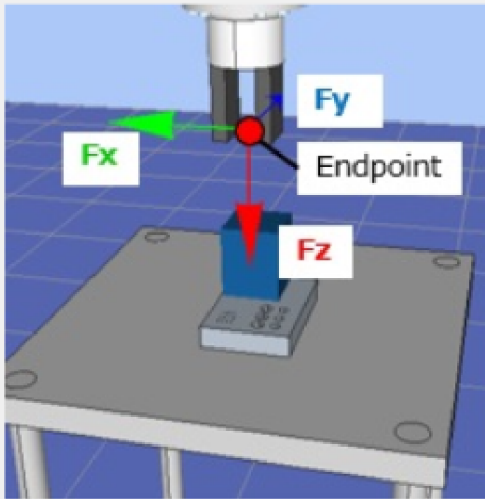

Cancel
< Back
Next >
Teach...
Finish

Item	Value	Description
Tool	1	Specify the number set for the tool used in this sequence.

5. The [Step 5: Set tool offsets] dialog box is displayed.

Set tool offset values. These settings can be left as the default values and do not need to be changed.

Click the [Next] button.

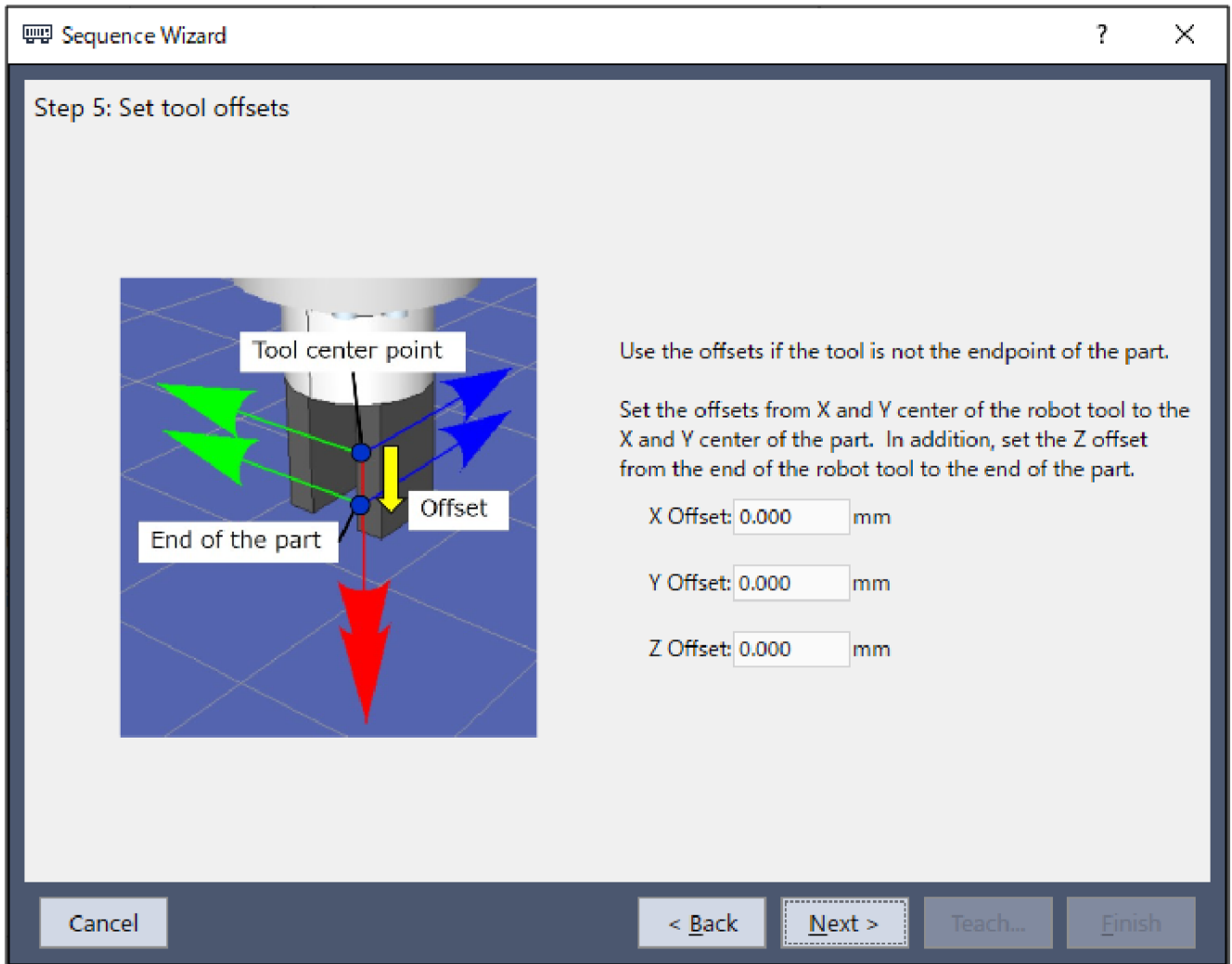

6. The [Step 6: Set height inspection method and direction] dialog box is displayed.

Select the [Part contact in robot coordinate system] button for [Inspection Method], and select "Base" for [Robot local].

This tutorial performs the height inspection to +Z direction of the tool.

When the Z axis of the tool coordinate system is in the vertical-downward direction, it is parallel and opposite to the Z axis

of the base coordinate system. Select the -Fz direction in the base coordinate system as the inspecting direction. Click the [Next] button.

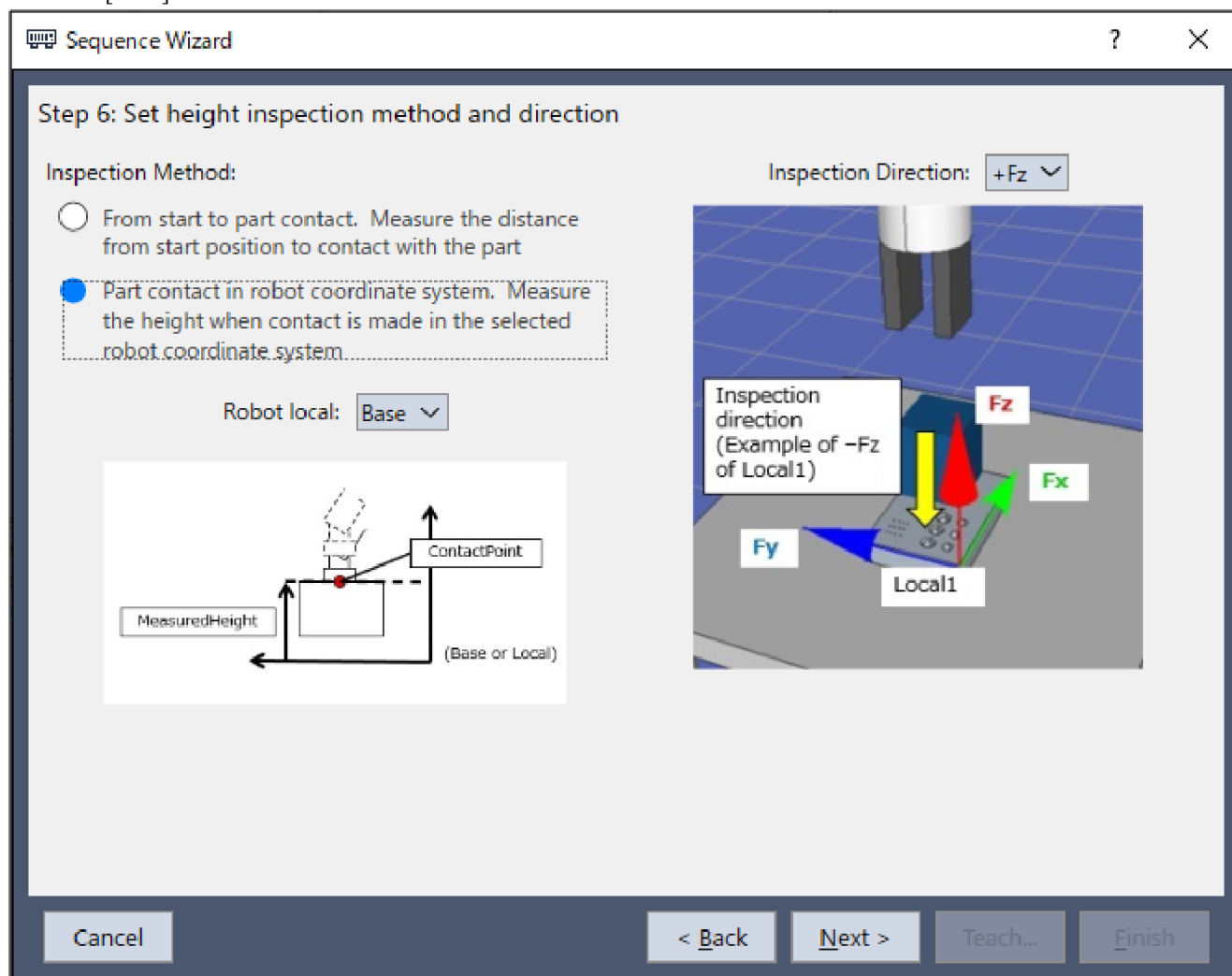

7. The [Step 7: Configure the reference position and tolerance] dialog box is displayed. Change the properties according to the table below.

Click the [Next] button.

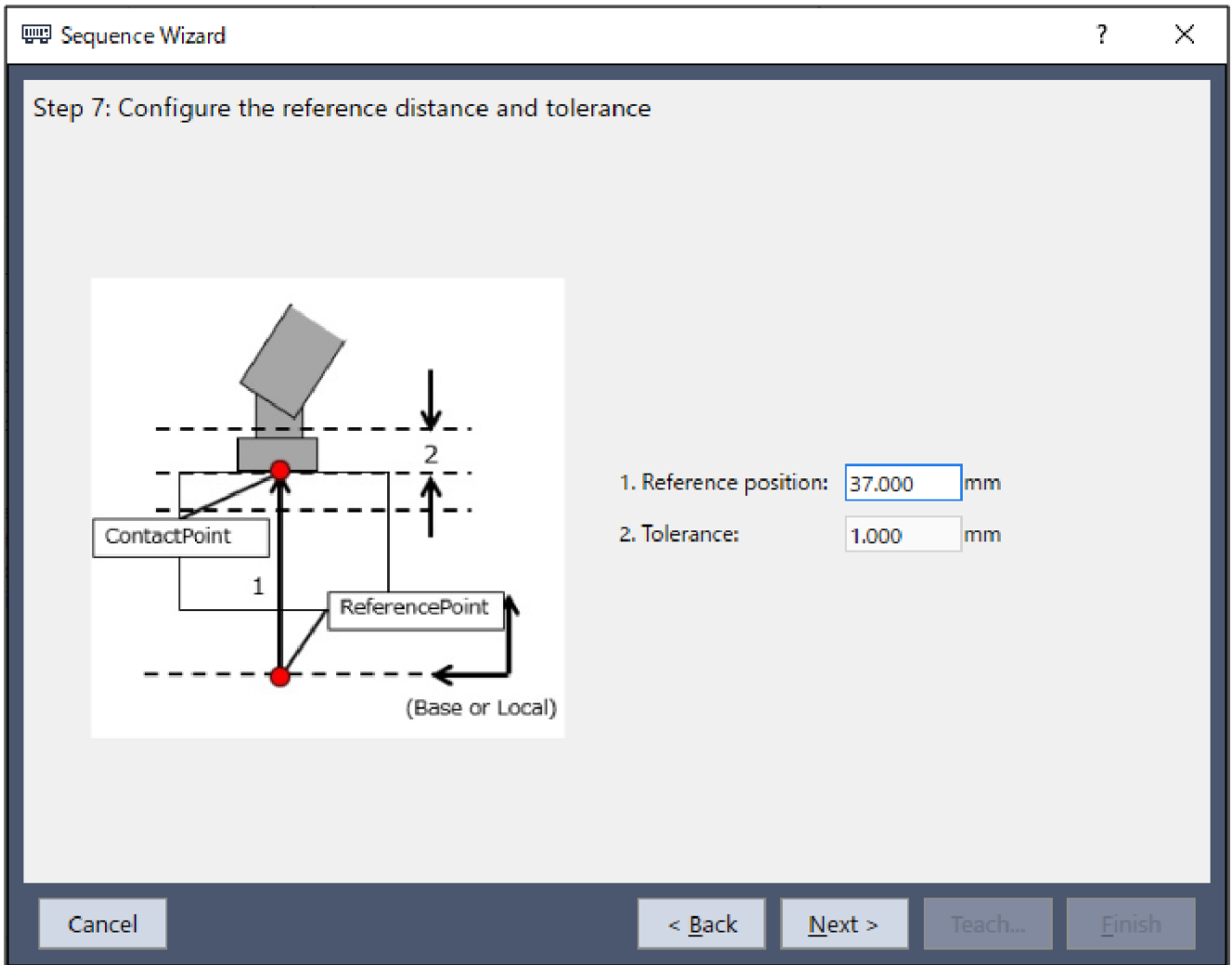

Item	Value	Description
Reference position	37	Set the position of the Z coordinate that determine the height inspecting process has ended successfully on the base coordinate system when the tool coordinate system is set to 1. Set the position according to your operating environment. The position is set to 37mm in this tutorial.
Effective Range	1	Set the tolerance of the position to be determined that the height inspection has ended successfully. Set this to 1mm.

- The [Step 8: Set height inspect speed] dialog box is displayed. Select [Select speed based on material toughness]. Change the properties according to the table below.

Click the [Next] button.

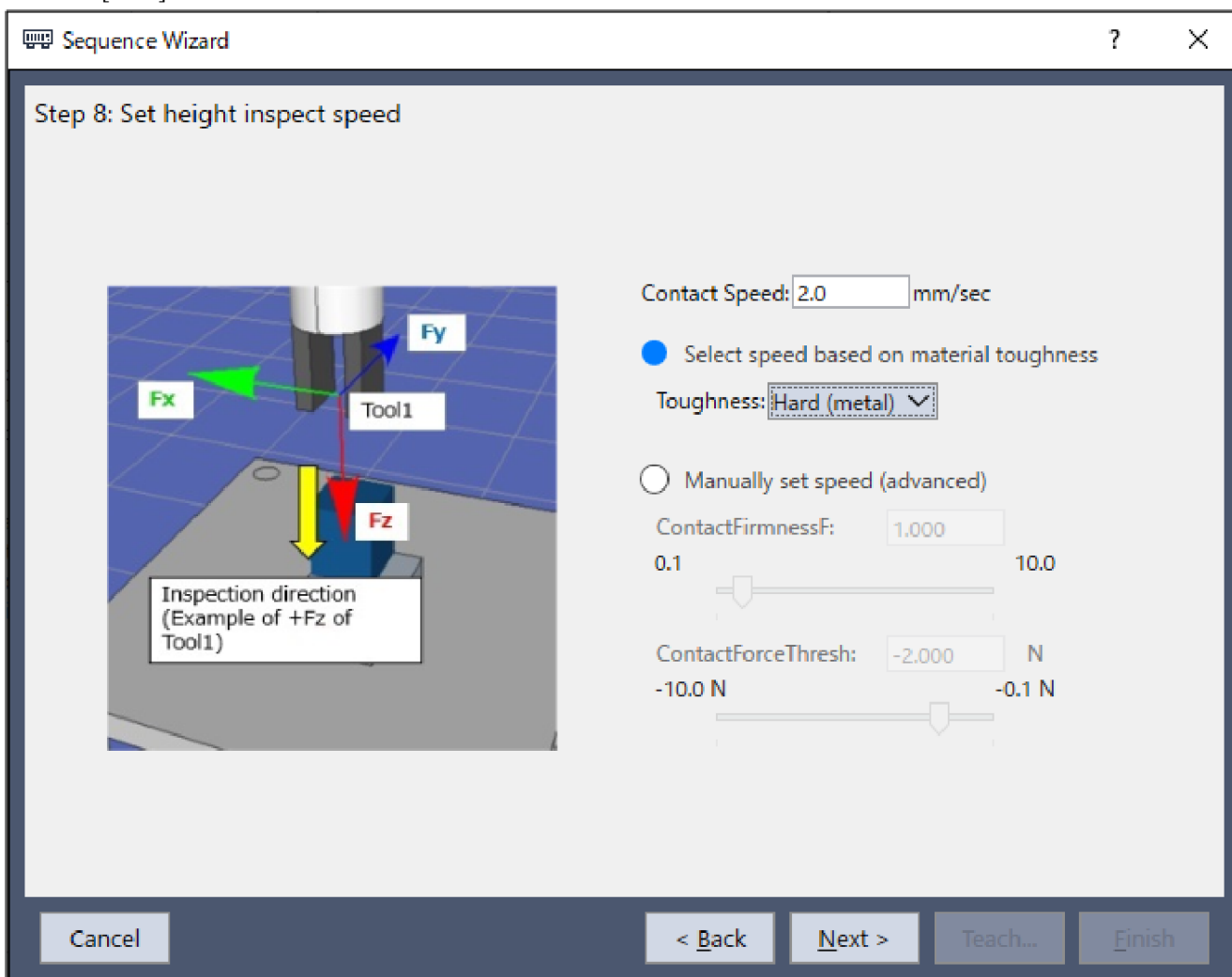

Item	Value	Description
Toughness	Hard(Metal)	Set contact speed the firmness of the Work piece. When selecting Hard (Metal), the contact speed is 2mm/sec.

- The [Step 9: Set the timeout for the operation] dialog box is displayed.
Change the properties according to the table below.

Click the [Next] button.

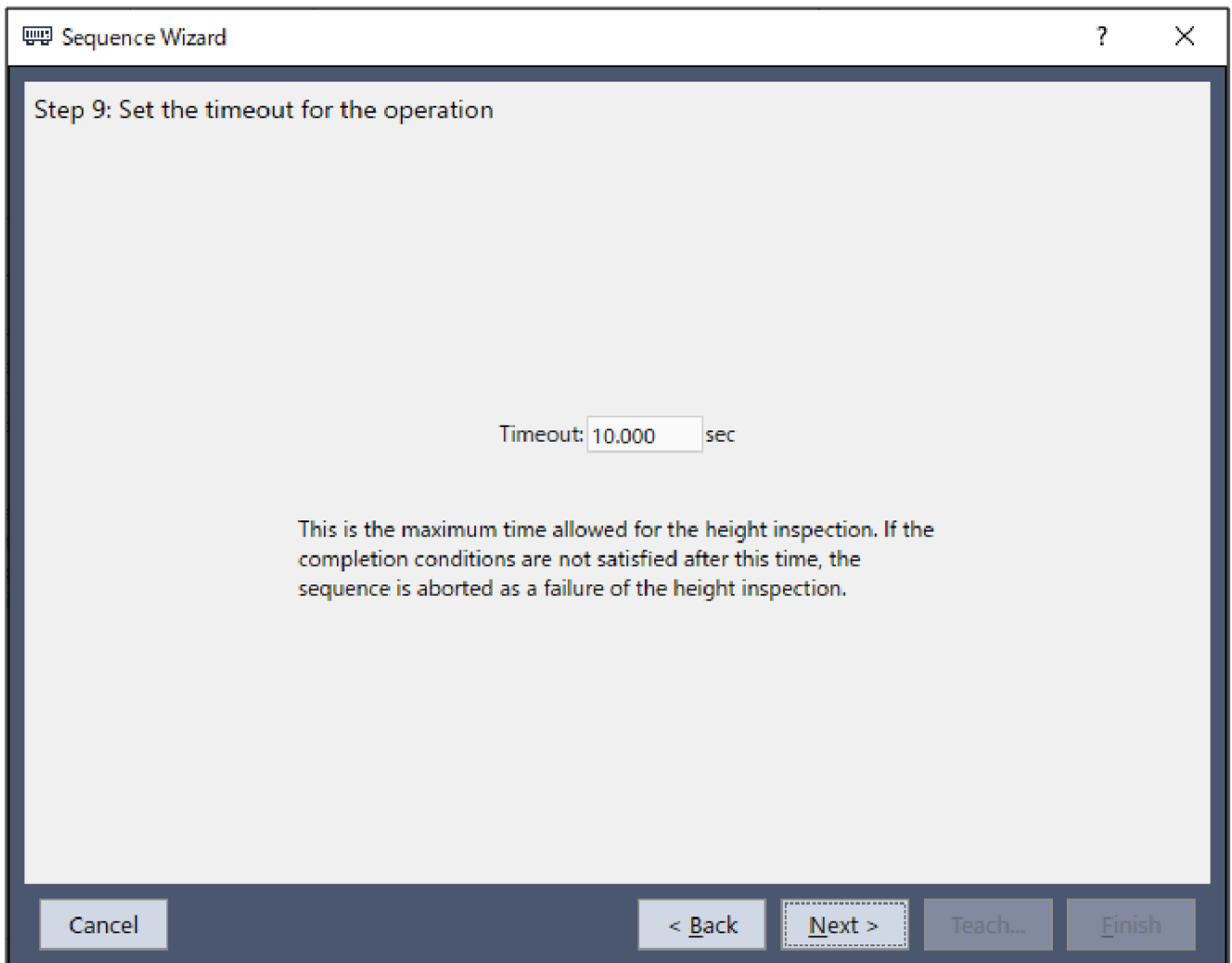

Item	Value	Description
Timeout	10	Set the time-out duration. Set this to 10 seconds.

10. The [Finish] dialog box is displayed. Click the [Finish] button.

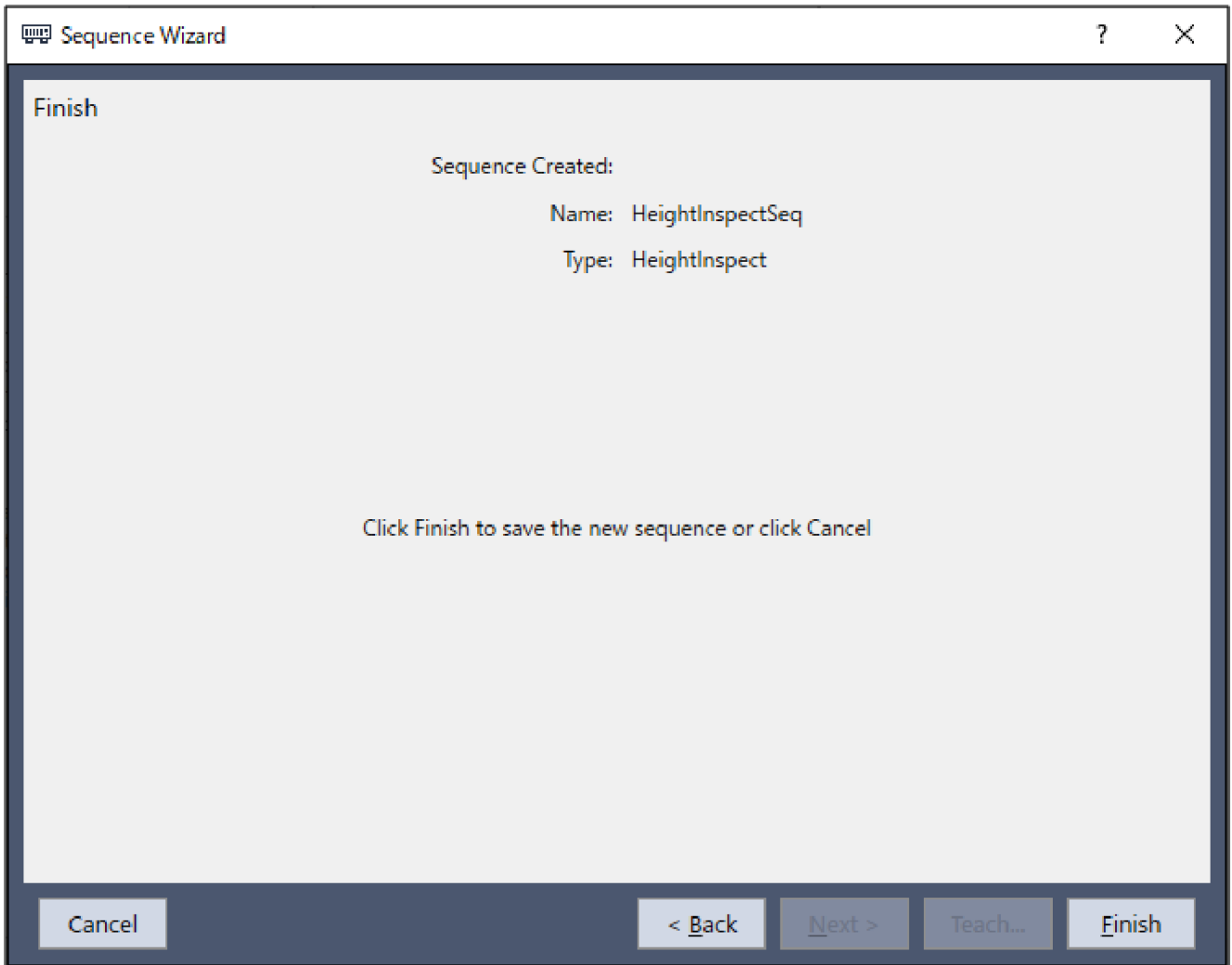

Check to make sure the [HeightInspectSeq] sequence has been created.

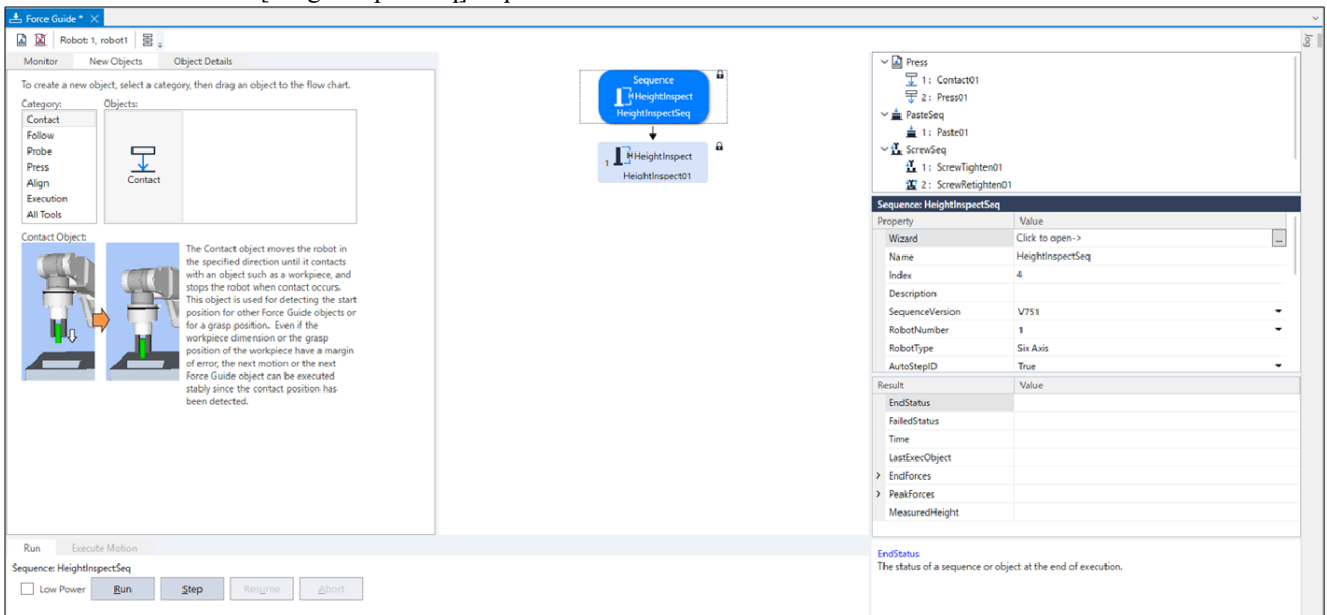

4.6.3.3.4 Setting Confirmation

The following describes how to check whether the settings for inspecting direction are correct by using a simulator.

1. Click Epson RC+ menu-[Tools]-[Simulator].
The [Simulator] window is displayed.

2. Click the object tree-[Tool].

Place a checkmark in the "No.1"-[Visible] check box. An arrow for "Tool 1" is displayed.

3. Click the object tree-[Force]-[Force Guide]-[HeightInspectSeq].

Place a checkmark in the "HeightInspect01"-[Visible] check box.

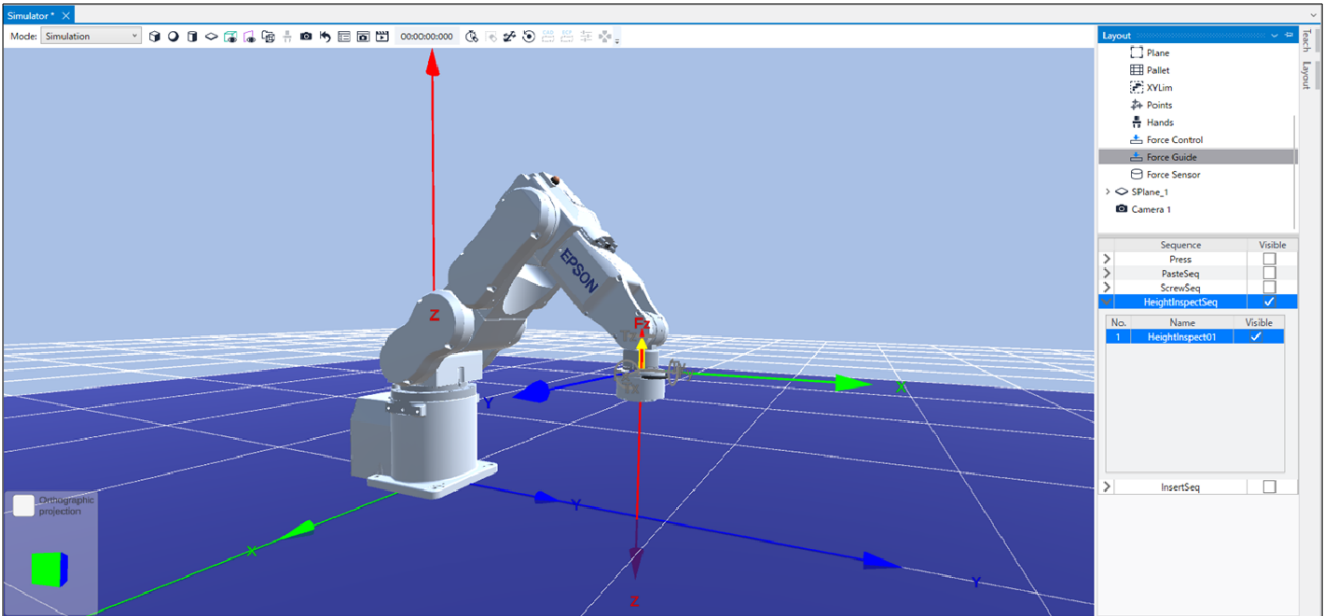

Confirm that the yellow arrow direction is the same as the inspecting direction.

4.6.3.3.5 Motion by Force Guidance Function

The following describes how to run the created HeightInspect sequence by Epson RC+.

1. Open the [Force Guide] window.

2. Select the [Jog] tab.

3. Click the [POWER HIGH] button.

If the robot might break the workpiece, operate in "Low Power Mode".

4. Click the [Run] button.

Program is compiled and transmitted to the Robot Controller.

If the setting is not correct, an error occurs. Check the settings so far and follow the error message to modify the parameters.

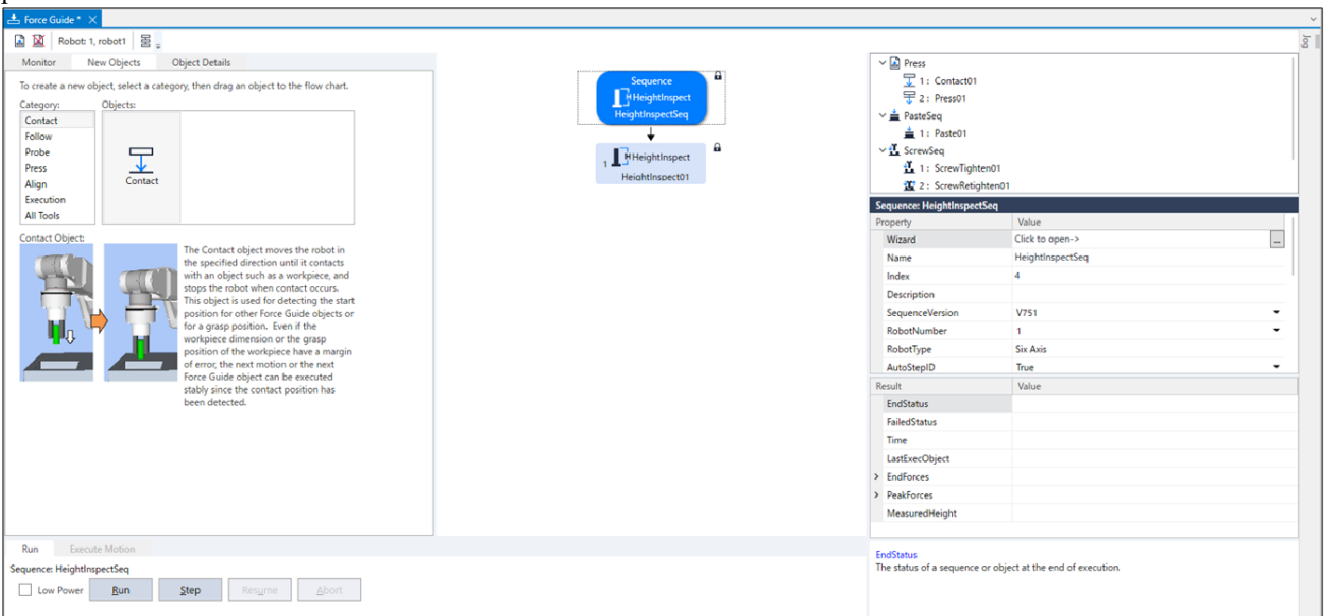

5. When the operation is performed properly,  is displayed on the upper left of the flowchart and the height inspection is completed.

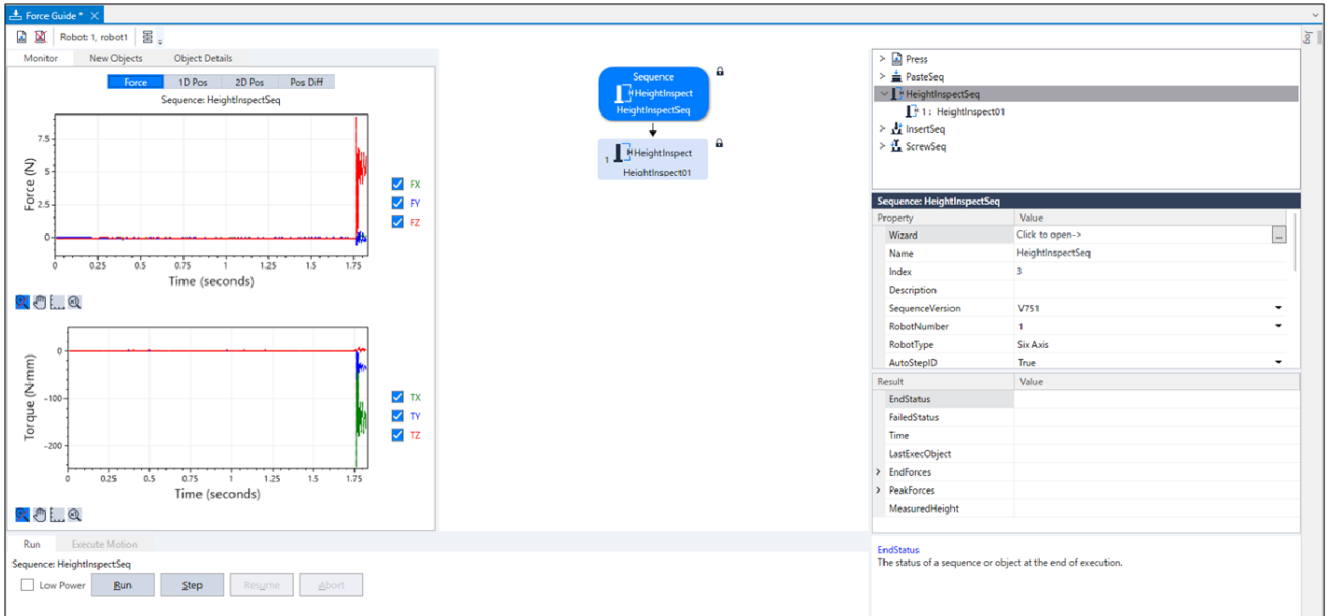

4.6.3.3.6 Return to the Non-Contact State

After completing HeightInspect sequence, force continues to be applied to between the robot and the workpiece. To prevent the robot and the end effector from malfunction or damages, after the operation ends, make sure that no force is applied to the object. If it is obvious that no force is applied to the object, you can omit this step.

Steps to return to a non-contact state are as follows:

- Click Epson RC+ menu-[Tools]-[Robot Manager]-[Jog & Teach] panel-[Jog] group and perform jog motion manually to move the robot away from the object.
- Click Epson RC+ menu-[Tools]-[Robot Manager]-[Jog & Teach] panel-[Execute Motion] tab and move the robot away from the object.
- Execute Move command on [Command Window] and move the robot away from the object.
- Add SPELFunc object after HeightInspect object, and automatically move the robot away from the object at the end of the force guide sequence.

The following describes how to return to non-contact state by clicking [Robot Manager]-[Jog & Teach]-[Execute Motion] tab.

1. Display the [Robot Manager] dialog box.
2. Click the [Jog & Teach] tab.
3. Select the [Execute Motion] tab.
4. Select "Move" in [Command].
5. Select "P1" in [Destination].
6. Click the [Execute] button.

The robot moves to the start point: P1. Now, it is the non-contact state.

4.6.3.3.7 Motion Analysis by Monitor

The following describes how to use Epson RC+ to check the operation results of a force guide sequence.

1. Open the [Force Guide] window.
2. Click the sequence flow of [HeightInspect].

- 3. The operation results (Passed / Failed), detected force values at the end of the robot motion, and the time that was required are displayed under [Result].
- 4. The graphs of force and position during the [HeightInspect] sequence execution are displayed in [Monitor].

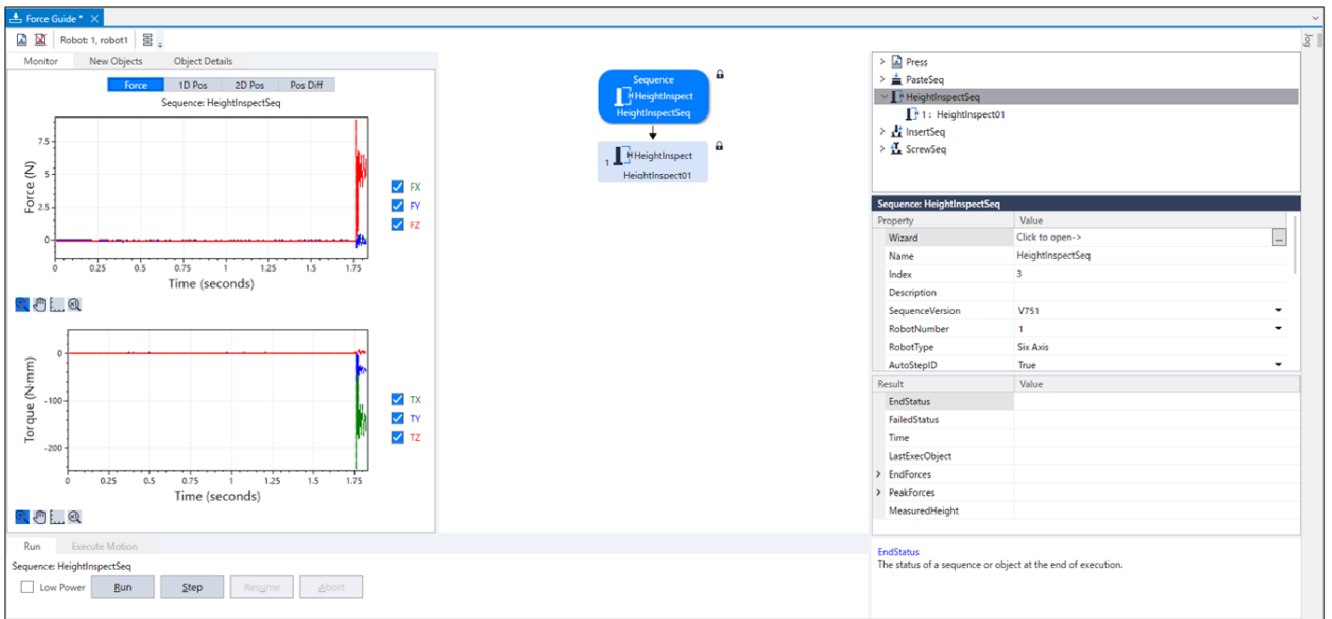

■ [1D Pos] tab

It is a graph for analysis. (horizontal axis: Time, vertical axis: Position)

The robot moves in the direction where CurZ of the position Z chart is getting low (small).

Since "Step 1" ends near 1.7 seconds and the force control has been completed, you can see that the value of RefZ (reference position) is falling (jumping) straight down to CurZ (current position).

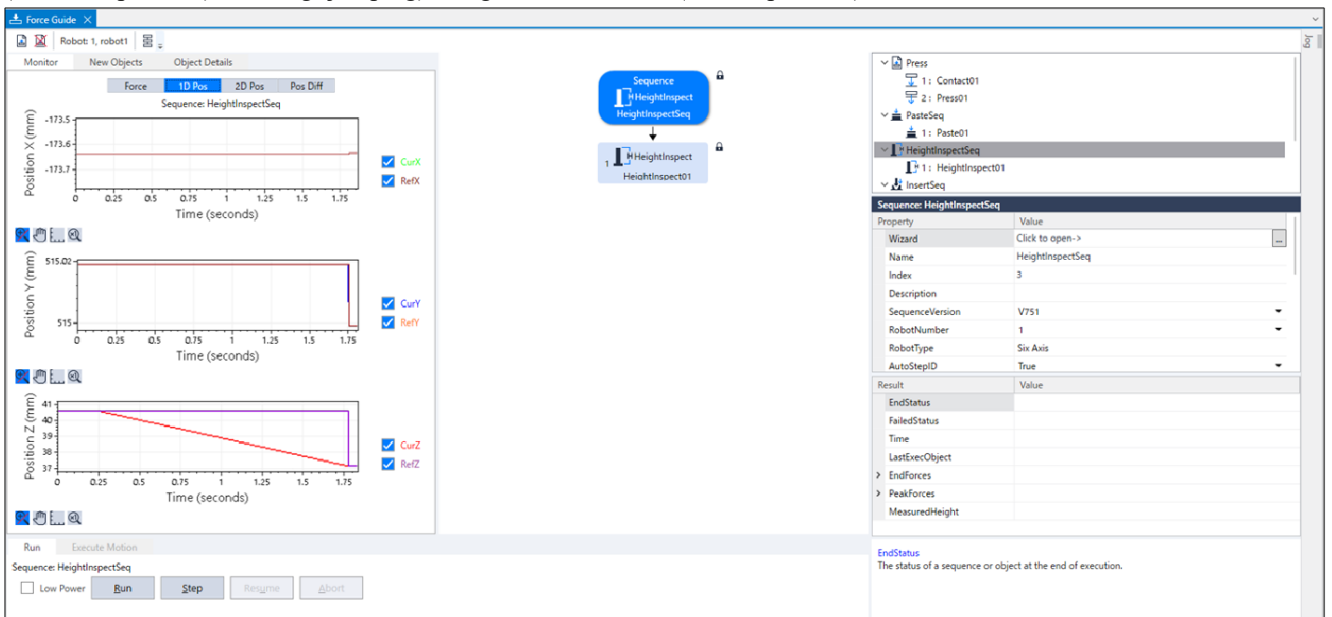

■ [2D Pos] tab

It is a graph for analysis. (horizontal axis, vertical axis: Position)

It is not required for the height inspection in this tutorial since the robot does not move in the X or Y directions.

■ [Pos Diff] tab

It shows the relative change of positions due to the force control.

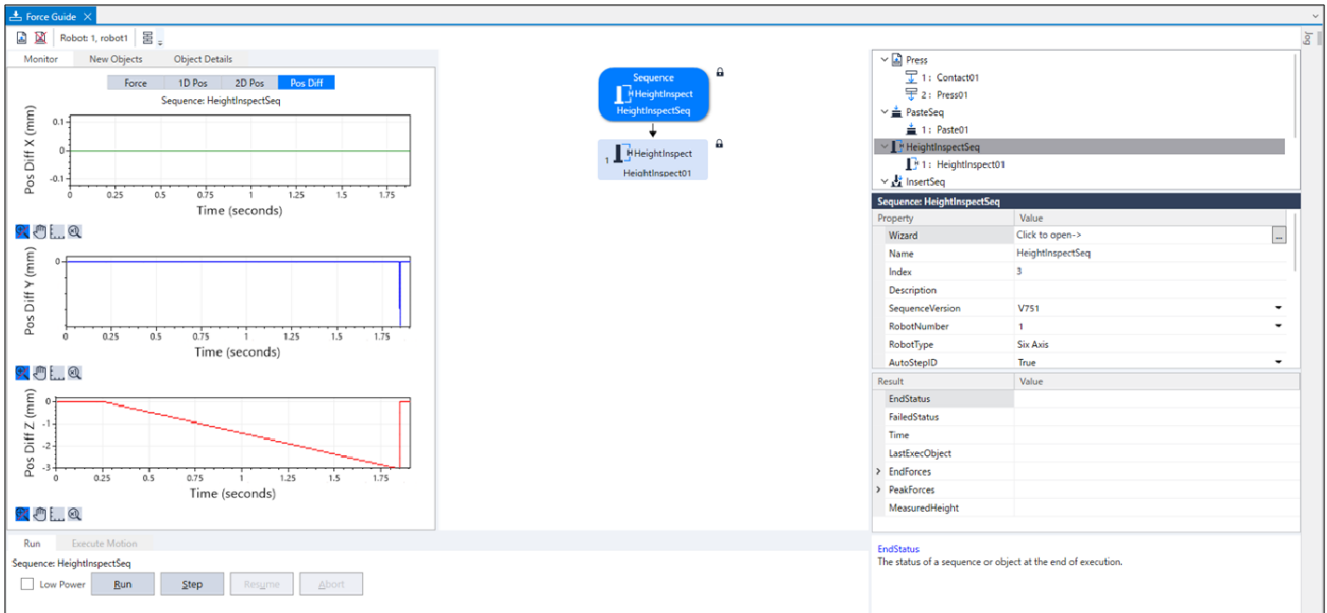

Change the unit of the graph and check the changes of force or positions.

If it is not inspected correctly, the setting may not be correct. Refer to the following and check the procedures of the tutorial.

- Whether a contacting direction is correct
- Whether the set reference position is largely moved from the point where the robot contacts the object to be inspected

This ends the HeightInspect sequence tutorial.

4.6.3.4 Insert Sequence

The following describes how to perform a peg in hole procedure using the Insert sequence of the system force guide sequence. Prepare a workpiece by yourself. Incorrect settings may result in damage of the workpieces. Prepare workpieces that can be damaged, and proceed with this tutorial.

Workpiece used in the picture is a training kit. If you need a drawing, please contact the supplier of your region.

The specifications are as follows.

- Cylinder on end effector side
Diameter: 20mm, Length 40mm

- Hole side Diameter
approx. 20mm, C plane: approx. 7mm

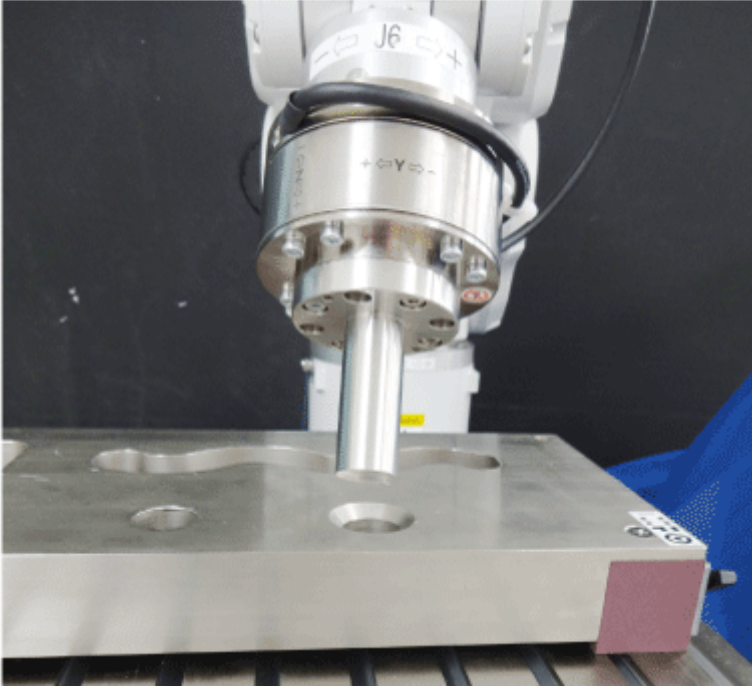

If you do not have a workpiece or a tool as shown above, you can try it easily by using a cylindrical wood, cork, and a plastic bottle. However, do not use a workpiece that has risks when it brakes such as a glass. Broken pieces will be scattered and may result in injury. Also, pay attention to surroundings when you proceed this tutorial.

CAUTION

The parameters described in the example on the following pages are reference values.

This tutorial uses relatively stable parameters, but depending on the operating environment, the operation may not be successful or the motion may be vibratory. Note that adjusting the parameters may be required. note that Slow, stable parameters are used for convenience of explanation. For high-speed operation, adjusting the parameters is required.

4.6.3.4.1 Confirmation of Tool Setting

During "Peg In Hole" task, the robot moves to X, Y, and Z directions while following to each rotation direction. Make sure to complete the tool setting when operating "Peg In Hole" task.

1. Use a caliper to measure distance from the J6 flange plane to the end of the cylinder.

In the case of the following picture, the distance is 109mm. (Force Sensor: 49mm, End Effector: 60mm)

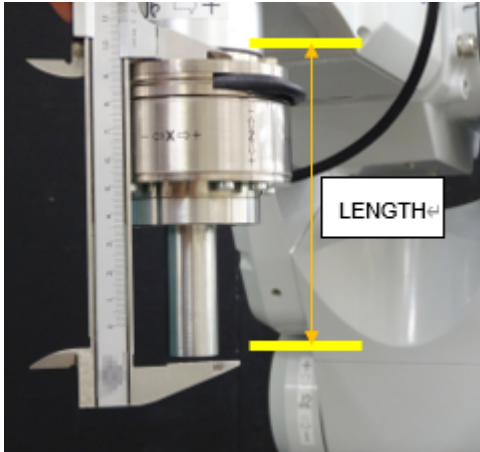

2. Execute the following command in [Command Window]. Enter the value measured in step (1) to "LENGTH". (unit: mm)
Set and select Tool 1.

```
> TLSet 1, XY( 0, 0, LENGTH, 0, 0, 0)  
> Tool 1
```

3. Click Epson RC+ menu-[Tools]-[Simulator].
The [Simulator] window is displayed.
4. Click the object tree-[Manipulator Name]-[Tool].
5. Place a checkmark in "No.1"-[Visible] check box.
6. Confirm the position and the orientation (direction) of Tool 1 by using both the simulator and the actual robot.
If they are different, check the settings and reset Tool 1.

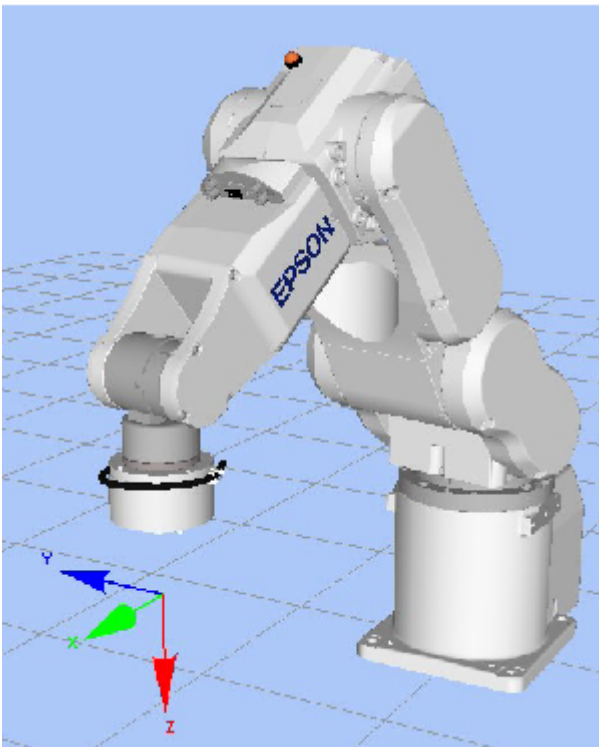

4.6.3.4.2 Position Teaching

The following describes how to teach a start position of "Peg In Hole" task.

1. Click Epson RC+ menu-[Tools]-[Robot Manager].
The [Robot Manager] dialog box appears.

2. Select [Jog & Teach] and open the panel.

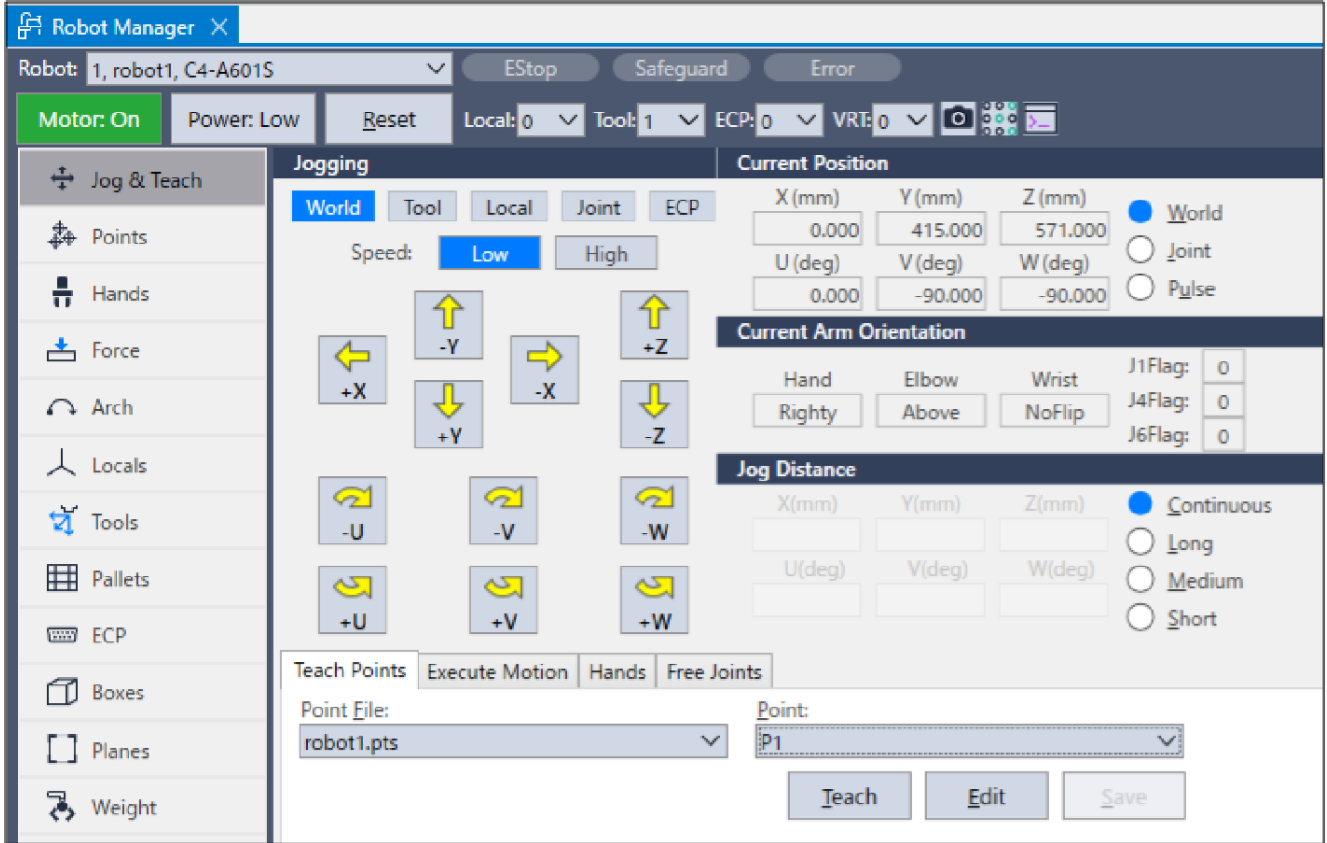

3. Select Epson RC+ menu-[Tools]-[Force Monitor]. The [Force Monitor] dialog box is displayed.
4. Click the [Start Live] button on the [Force Monitor] dialog box. Start to display the output value from the current Force Sensor.
5. Click the Jog button on the [Jog & Teach] window to move the robot to a position where the cylinder and the hole face each other.
Execute the following command in the command window if necessary.

```
> Go Align (Here)
```

By executing the above command, the robot will be a parallel orientation against the Base coordinate system based on the current position. The robot can move more easily when it and the contact point are facing one another.

For details, refer to the following manual:

"Epson RC+ SPEL+ Language Reference" Align Function

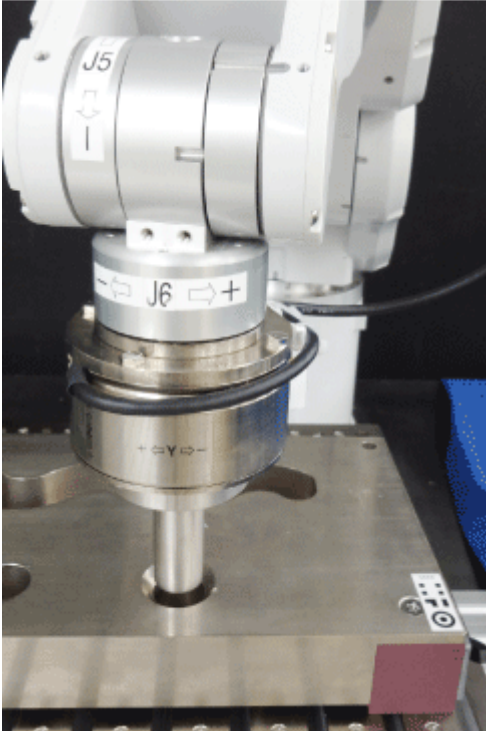

6. In the [Force Monitor] dialog box, click the [Reset Sensor] button. Eliminate the effect of gravity and drift of the sensor value, set the current position to "zero".
7. Click the Jog button on the [Jog & Teach] window to move the robot to a position where it is slightly away from the center of the insertion. To determine the distance from the operation start point and the opening of the hole, move the robot to a position where is slightly outside of taper (C plane).

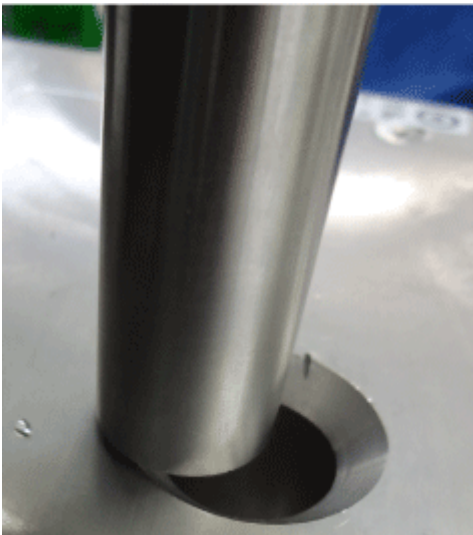

8. Select [Short] button on [Jog Distance]. Click the Jog button several times to move the robot to -Z direction until the robot contacts with the target object. When the robot contacts with the object, output value of Force Sensor changes. Check the changes of monitor value by the timing of the jog motion.

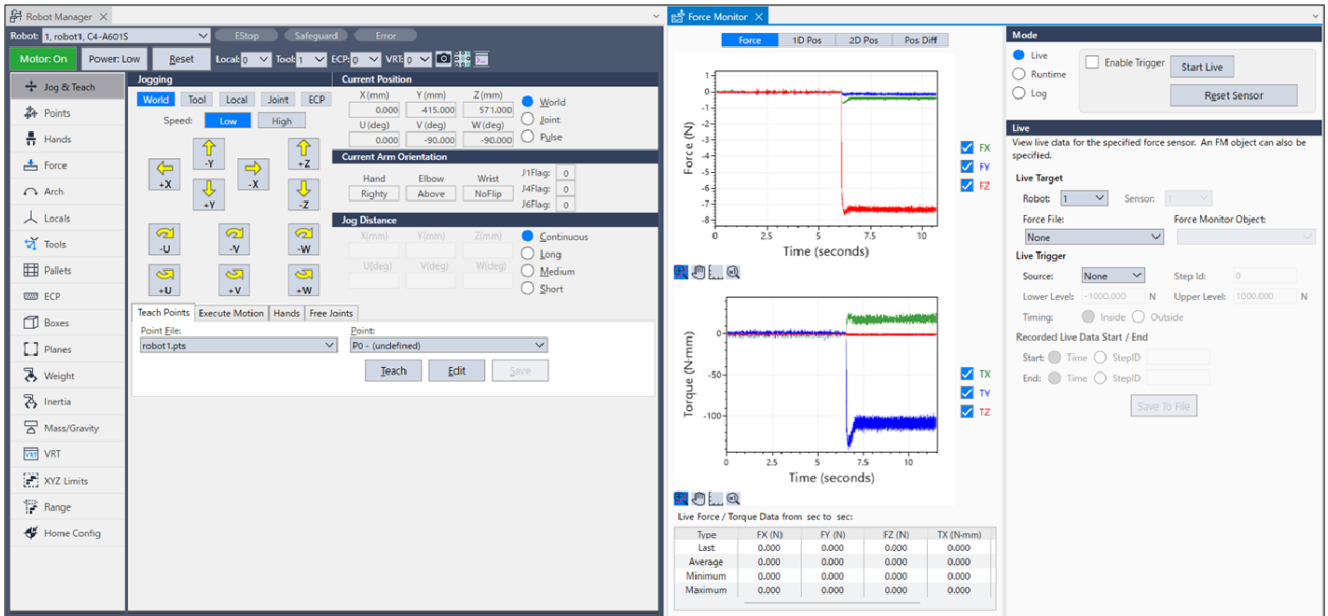

9. Select the [Medium] button on [Jog Distance]. Click the Jog button three times to move the robot 3mm in the +Z direction and put the cylinder into a non-contact state. In addition, click the Jog button several times in the XY direction to move the robot to a position where the cylinder makes contact with the taper when inserted in the +Z direction.

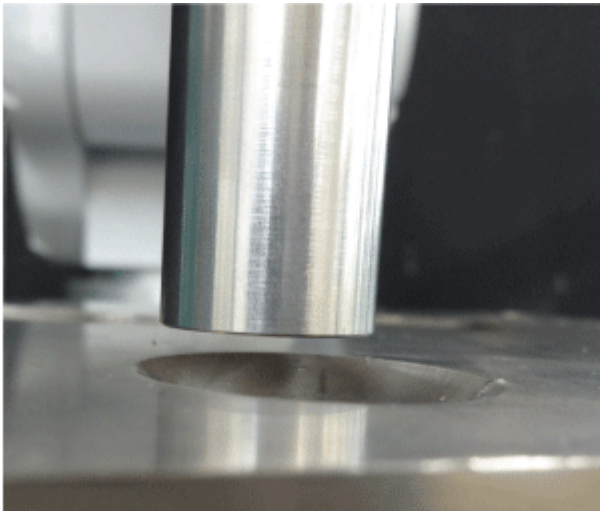

This is the start position for the insertion and the position where the Force Sensor is reset.

10. Select "P8" in the [Point] dropdown.
11. Enter "InsertStart" in [Point Label]. Click the [OK] button.
12. Click Epson RC+ menu-[File]-[Save All]. The file is saved.

4.6.3.4.3 Sequence wizard

The following describes how to create Insert sequence of the system force guide sequences.

1. Enter "InsertSeq" in the [Enter name for new sequence] box. Click the [Next] button.

Sequence Wizard

Step 1: General

Enter name for new sequence:
InsertSeq

Select robot for new sequence:
1, robot1

Copy from existing sequence:

Cancel < Back Next > Teach... Finish

2. The [Step 2: Select sequence type] dialog box is displayed.
Select [System]. Click the [Next] button.

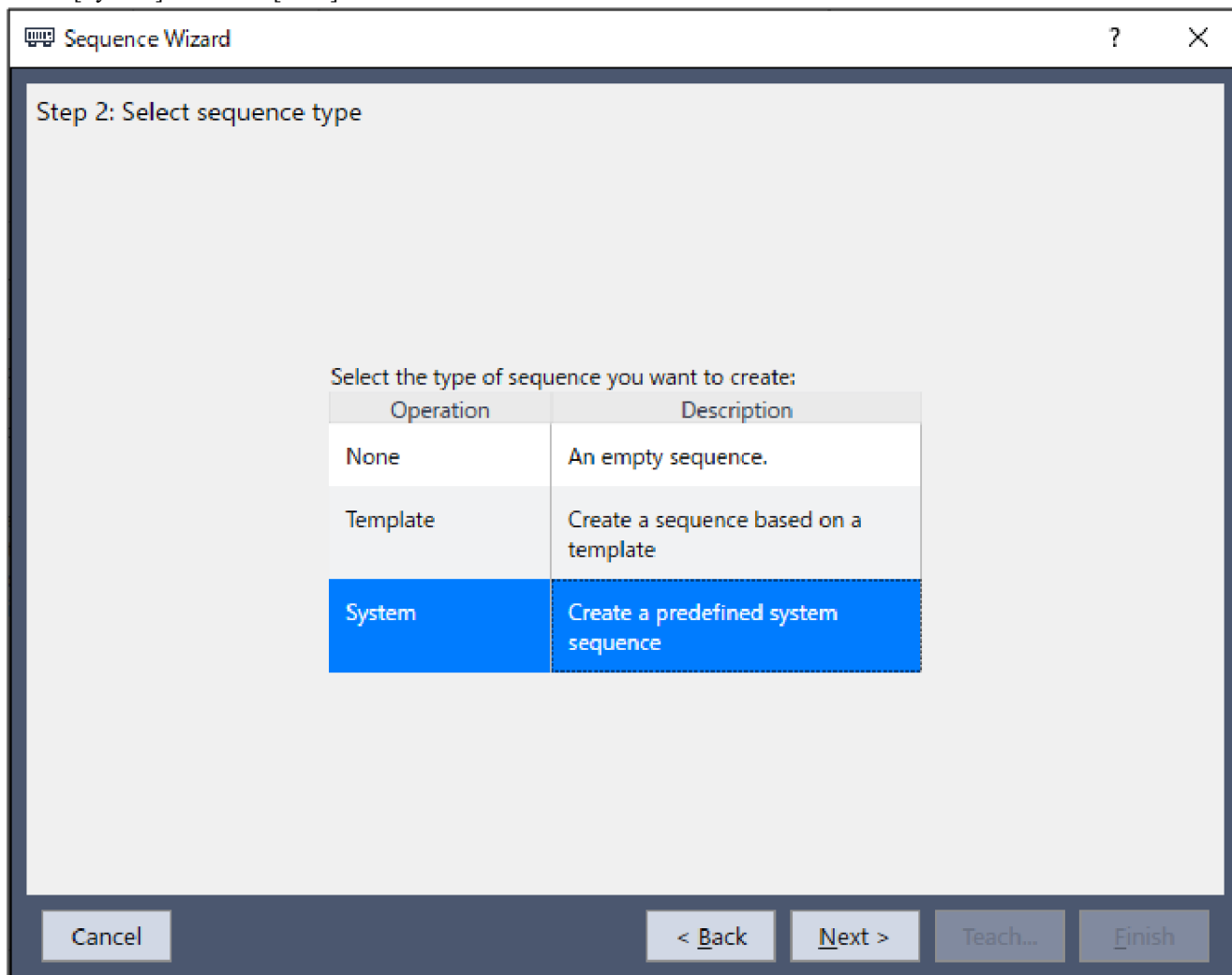

3. The [Step 3: Select system sequence] dialog box is displayed. Select [Simple insert]. Click the [Next] button.

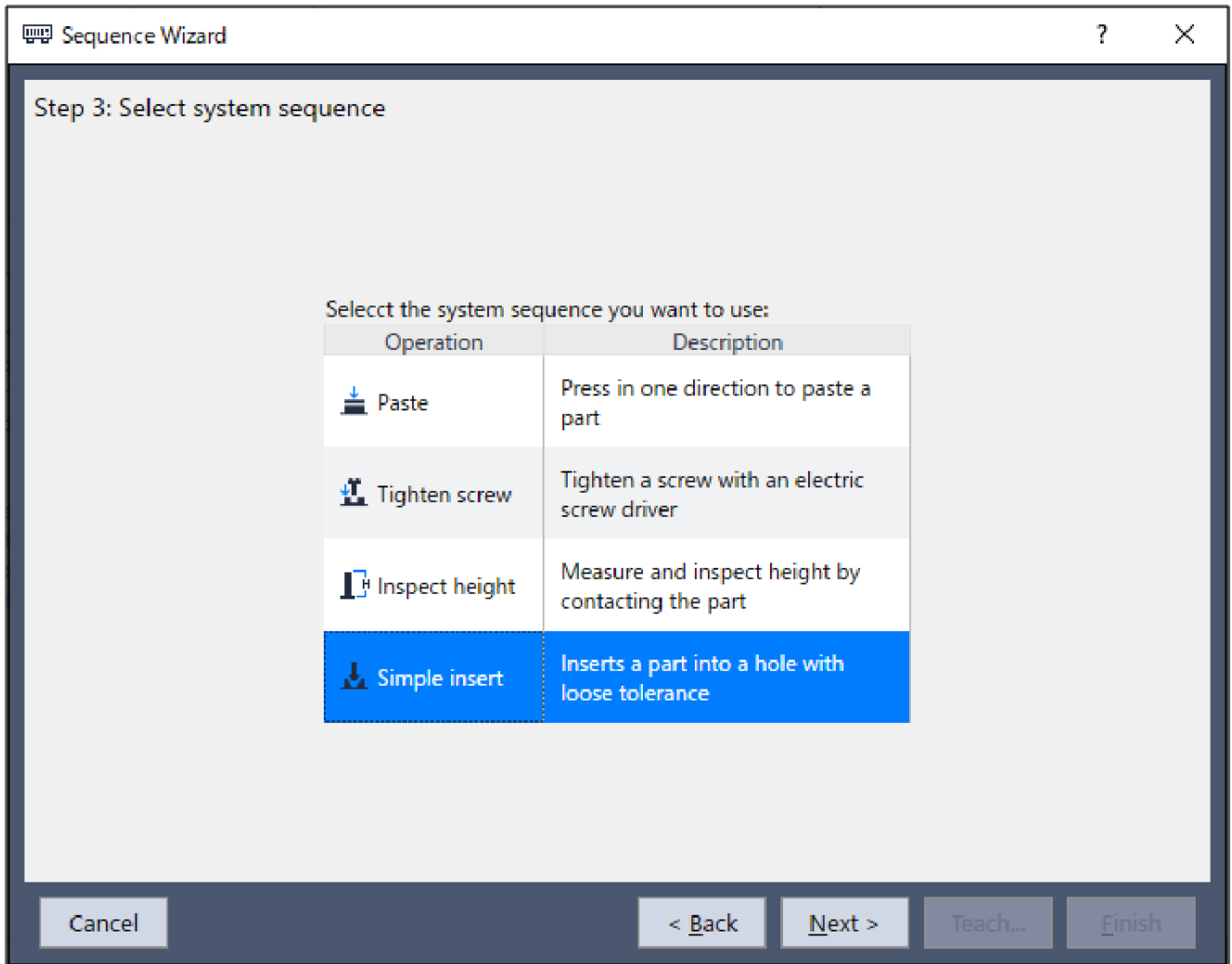

4. The [Step 4: Select the robot tool to use for the end effector] dialog box is displayed.

Change the properties according to the table below.

Click the [Next] button.

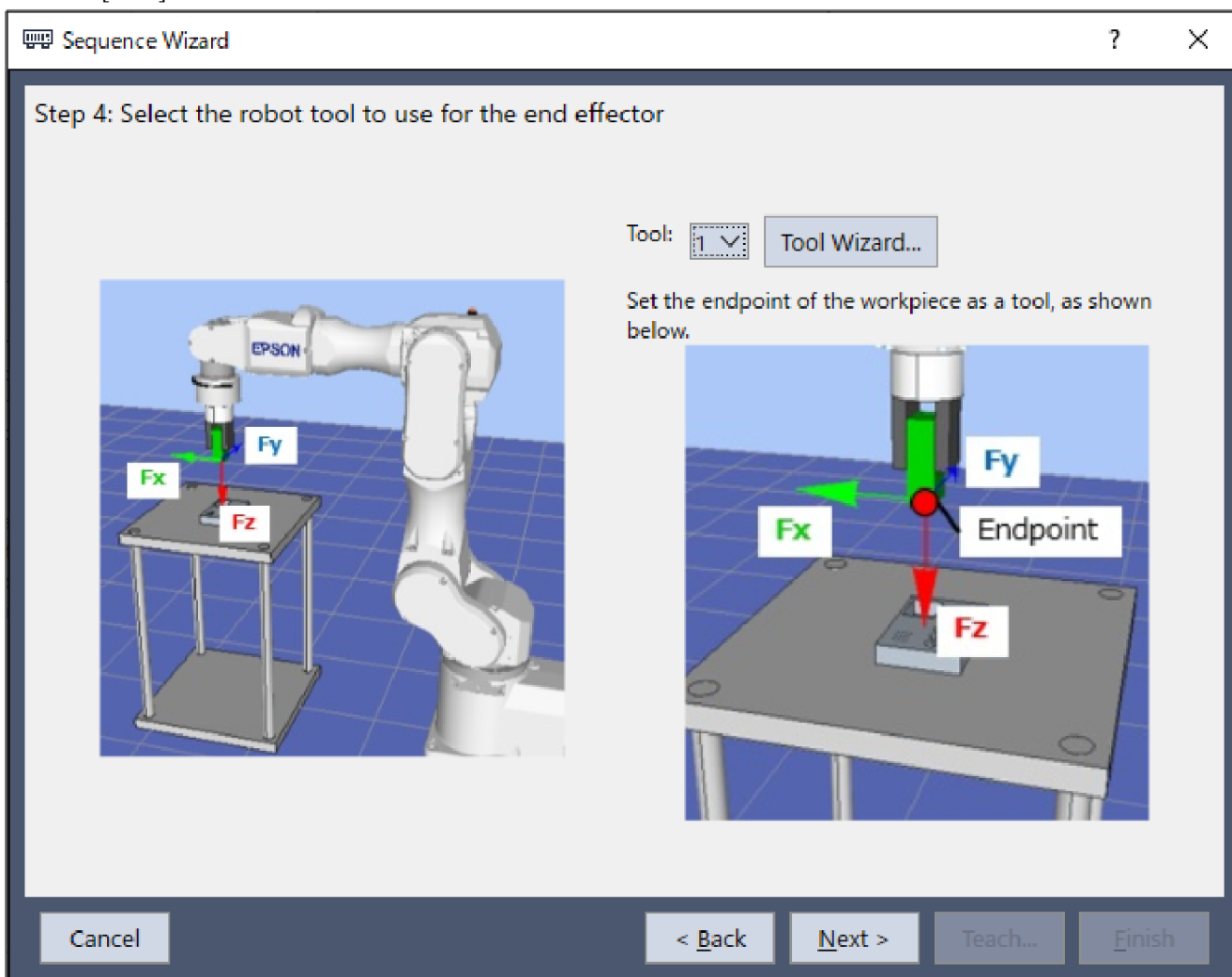

Item	Value	Description
Tool	1	Specify the number set for the tool used in this sequence.

5. The [Step 5: Set tool offsets] dialog box is displayed.

Set tool offset values. These values can be left as the default values and do not need to be changed.

Click the [Next] button.

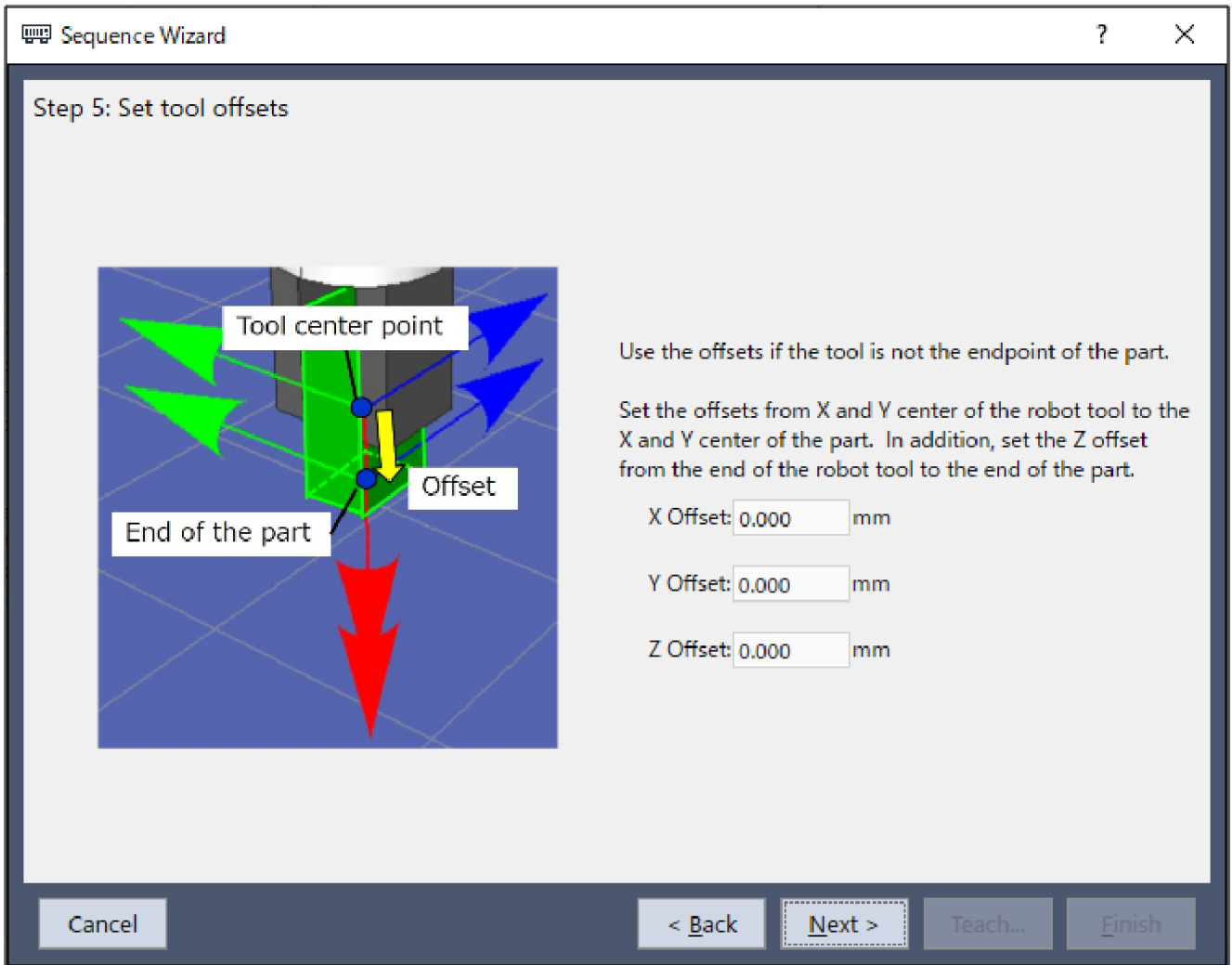

6. The [Step 6: Set insert coordinate system and direction] dialog box is displayed.

This tutorial performs the insertion to +Fz direction of the tool coordinate system.

(*1) As the coordinate system is set to tool and the insertion direction is set to +Fz, this value can be left as the default value and does not need to be changed.

Click the [Next] button.

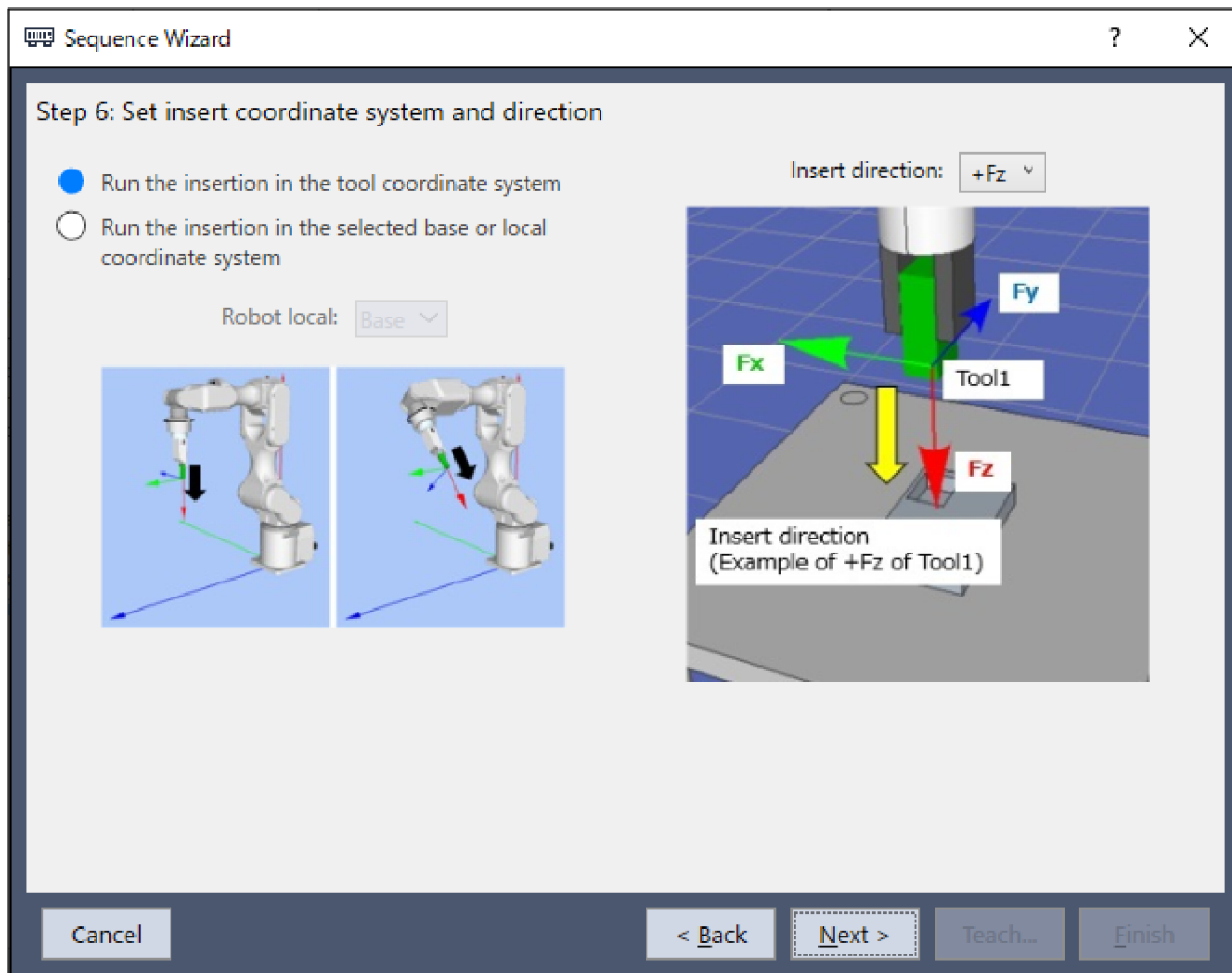

*1 [Reference]

	6-axis robot	SCARA robot
Robot motion image [Insert]		
(Press/Contact) Orient	+Fz	-Fz

	6-axis robot	SCARA robot
Sign of Force (monitor display is included)	-	+

7. The [Step 7: Set insert operation options] dialog box is displayed.
 Change the properties according to the table below.
 Click the [Next] button.

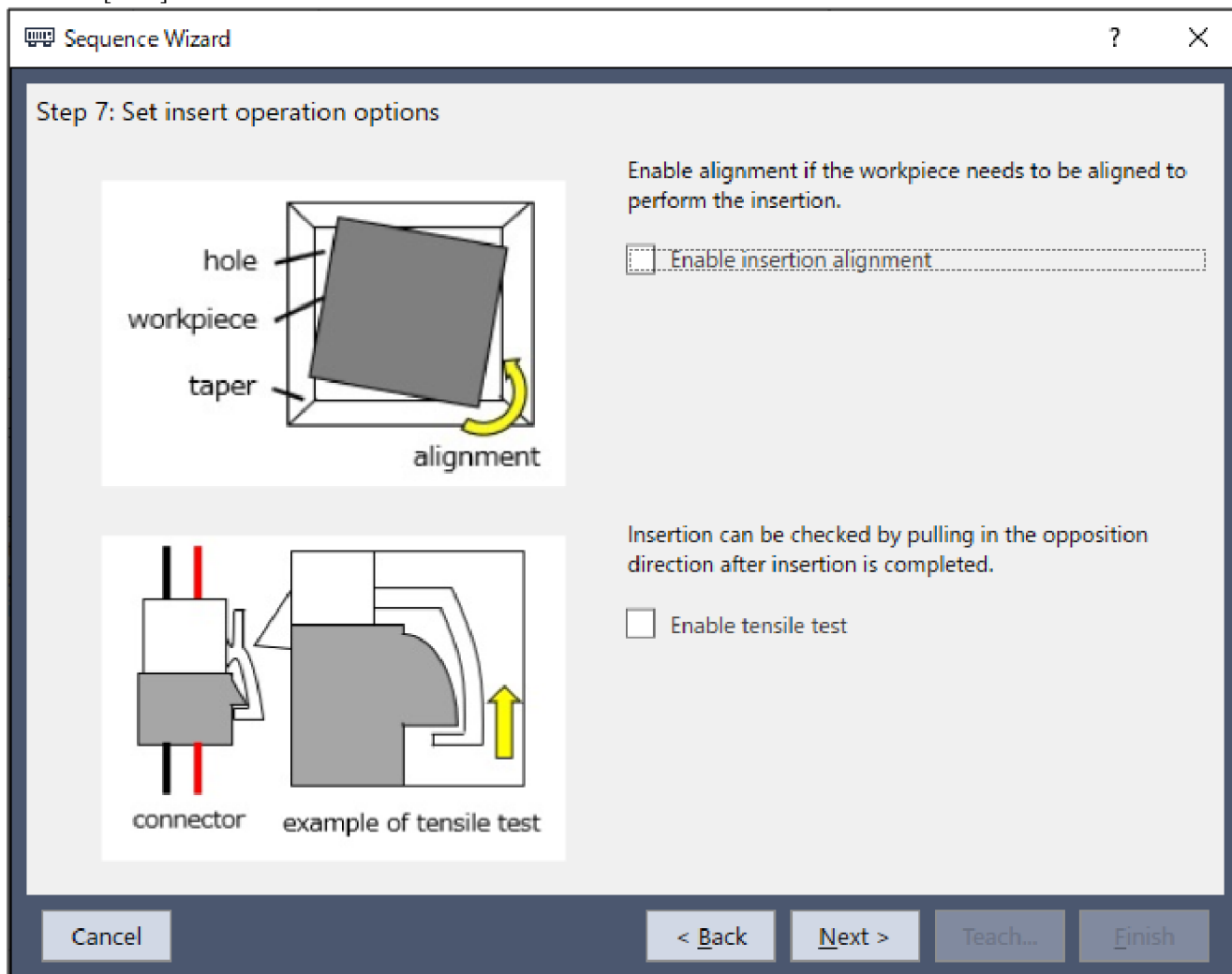

Item	Value	Description
Enable insertion alignment	Disable	The insertion alignment is enabled. The insertion alignment is not required since this tutorial uses a cylinder as a workpiece.

8. The [Step 8: Set insert approach distance and depth] dialog box is displayed.

Change the properties according to the table below.

Click the [Next] button.

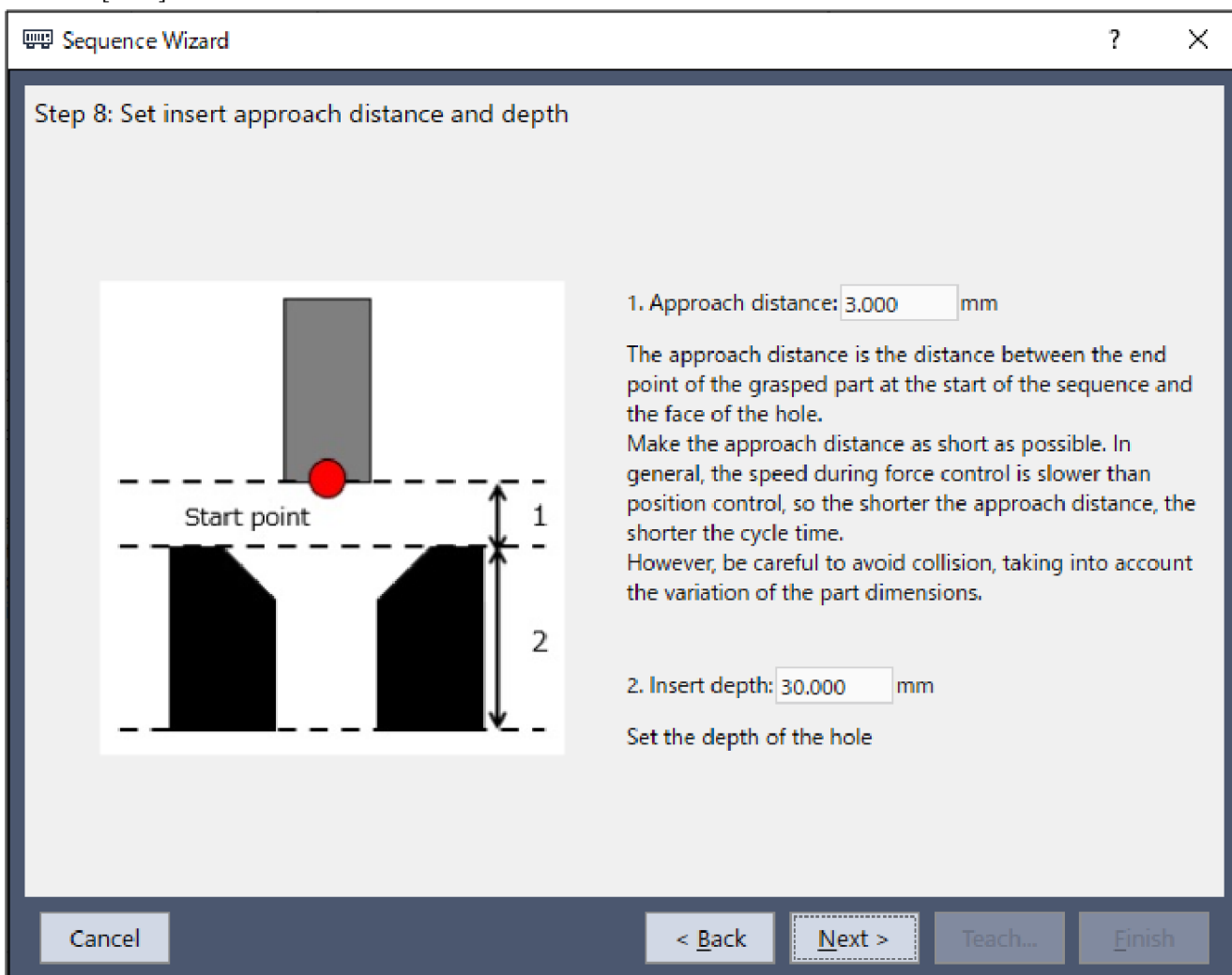

Item	Value	Description
Approach distance	3	Set the distance from the end of the cylinder to the hole face. Set this to 3mm.
Insert depth	30	Set the depth of the hole. Set this to 30mm.

9. The [Step 9: Set insertion parameters] dialog box is displayed.

Change the properties according to the table below.

Click the [Next] button.

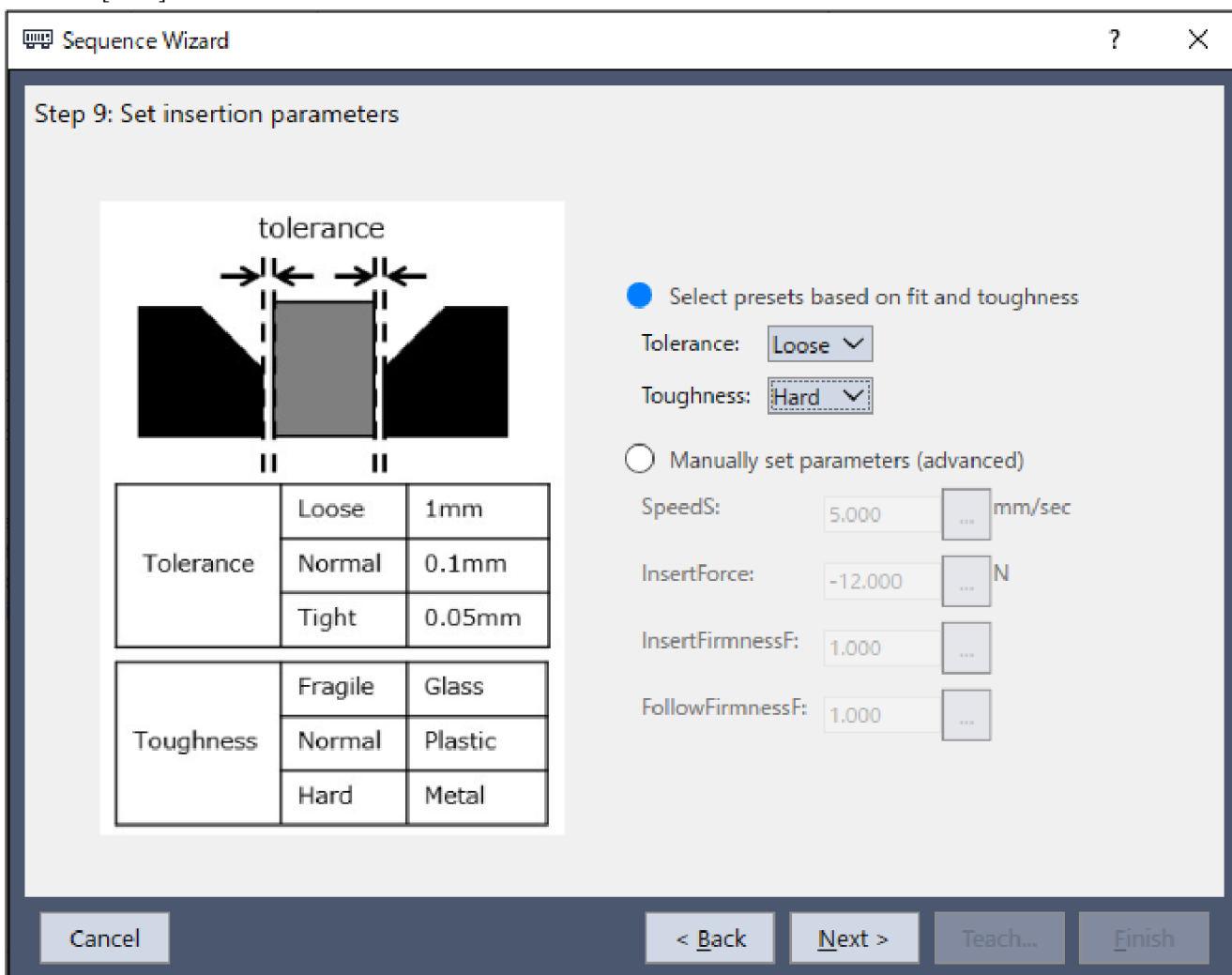

Item	Value	Description
Tolerance	Loose	Set the speed and force of insertion based on the tolerance of the cylinder and the hole. Select this according to the tolerance of the workpiece in use. When Loose is selected for Tolerance, the insertion speed is 5 mm/sec. When Loose is selected for Tolerance and Hard for Toughness, the insertion force is -12 N.
Toughness	Hard	Set the firmness of the force control function for the insertion force and the insertion force based on the firmness of the cylinder and the hole. Select this according to the material of the workpiece in use. When selecting Hard for Toughness, the firmness of the force control function in the insertion direction is 1.

10. The [Step 10: Set insert follow firmness] dialog box is displayed.

Change the properties according to the table below.

Click the [Next] button.

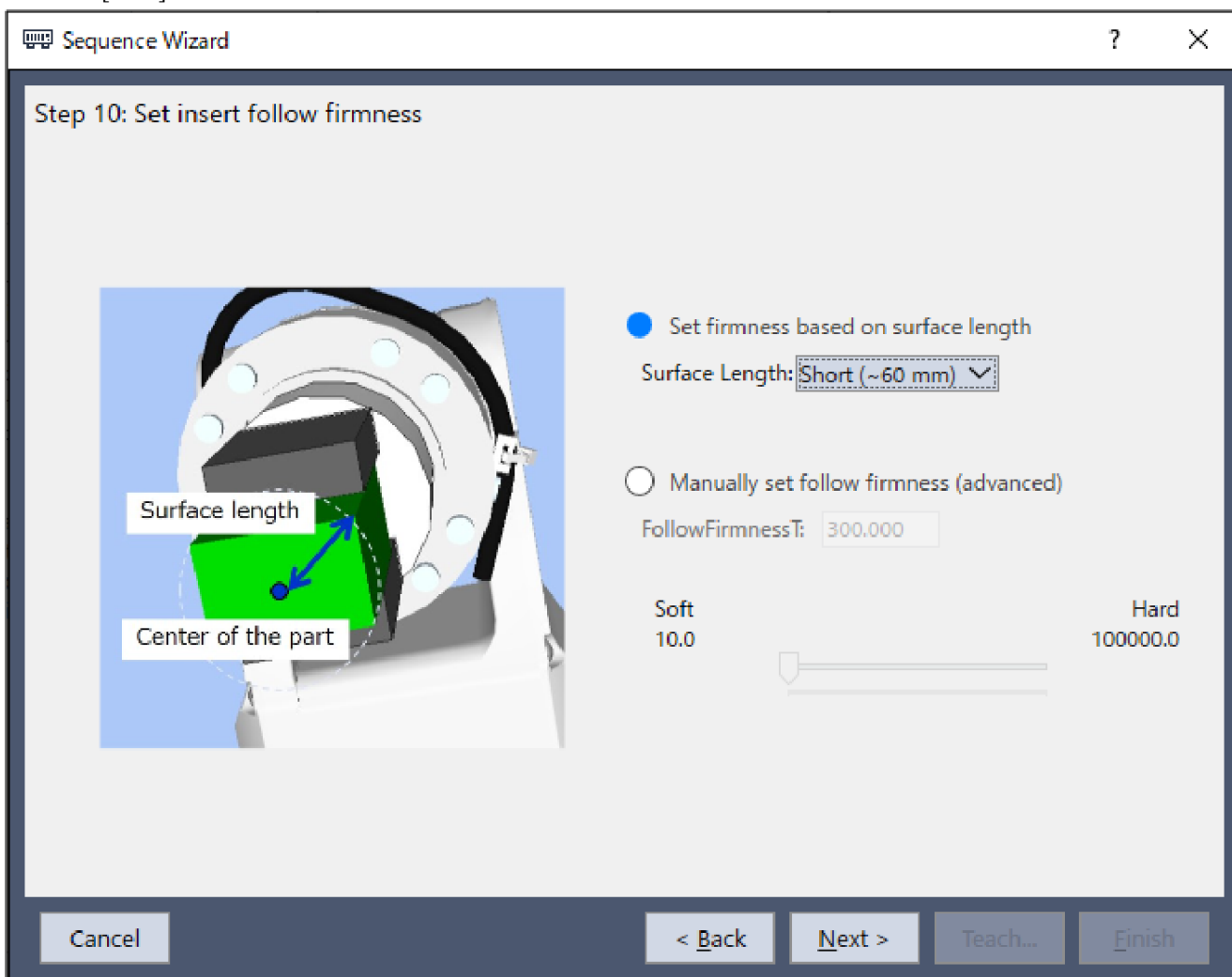

Item	Value	Description
Surface Length	Short (up to 60 mm)	Set the firmness of the force control function in the following direction based on the distance from TCP to the end of the workpiece. Select this according to the tolerance of the workpiece in use. When Short (up to 60 mm) is selected for Surface Length, the firmness of the force control function in the follow direction is 300.

11. The [Step 11: Configure the completion conditions for the insert operation] dialog box is displayed. When each property setting is changed, the completion conditions of the inserting operation. In this tutorial, the values do not need to be changed from the default values. Click the [Next] button.

Sequence Wizard

Step 11: Configure the completion conditions for the insert operation

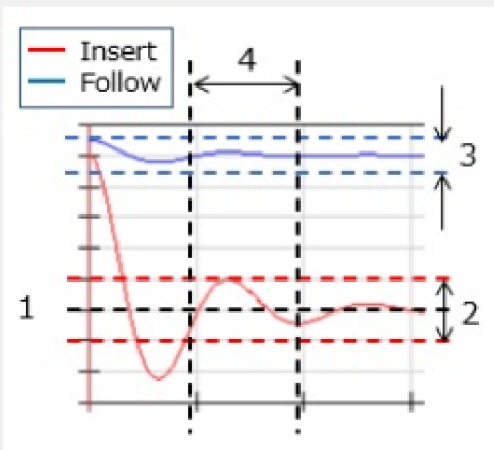

Set the tolerances for insert force (2) and follow force and torque (3) that must be achieved for the specified duration (4).

2. Insert Force Tolerance: N

3a. Follow Force Tolerance: N

3b. Follow Torque Tolerance: N*mm

4. Completion Duration: sec

Cancel < Back Next > Teach... Finish

12. The [Step 12: Set the timeout for the operation] dialog box is displayed. This setting does not need to be changed from its default value. Click the [Next] button.



13. The [Finish] dialog box is displayed. Click the [Finish] button.

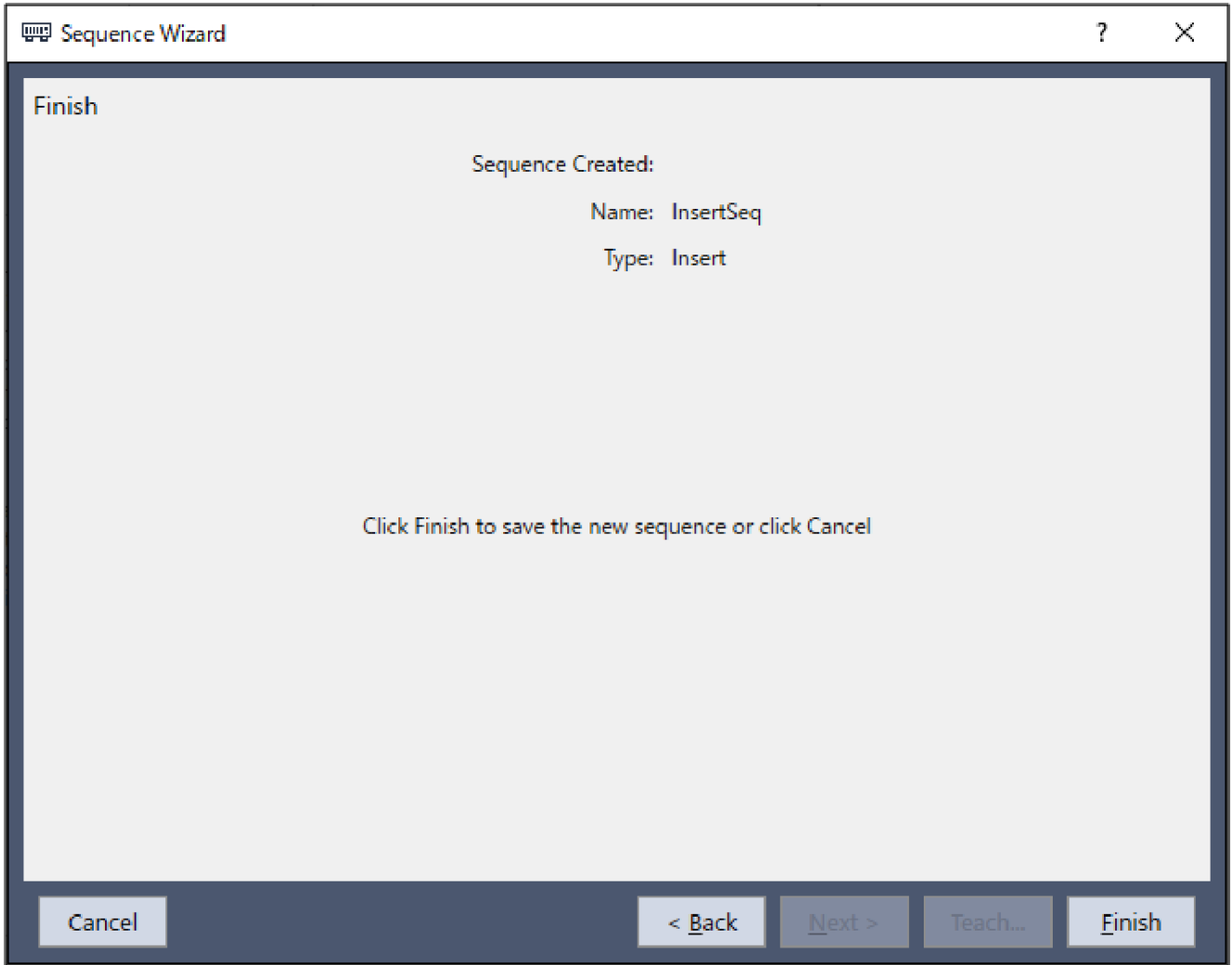

14. Check that the [InsertSeq] sequence has been created.

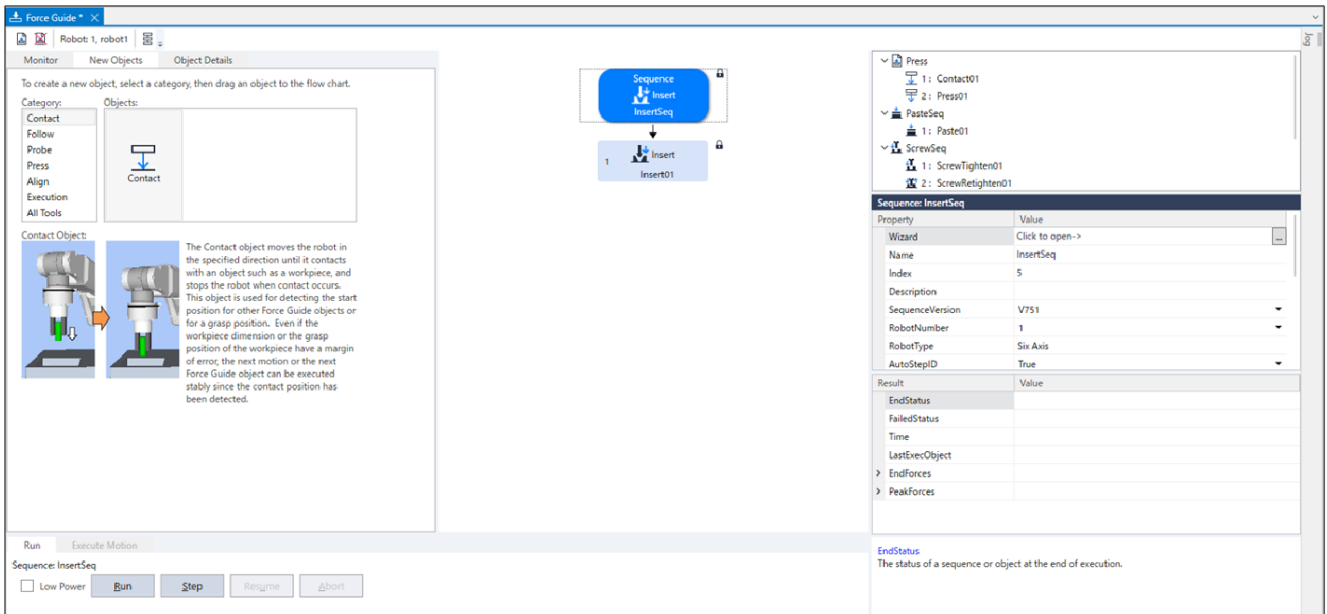

4.6.3.4.4 Setting Confirmation

The following describes how to check whether the settings for insertion direction are correct by using a simulator.

1. Click Epson RC+ menu-[Tools]-[Simulator].
The [Simulator] window is displayed.
2. Select object tree-[Force]-[Force Guide]-[InsertSeq].
3. Place a checkmark in the following check box.
[Insert01]-[Visible]

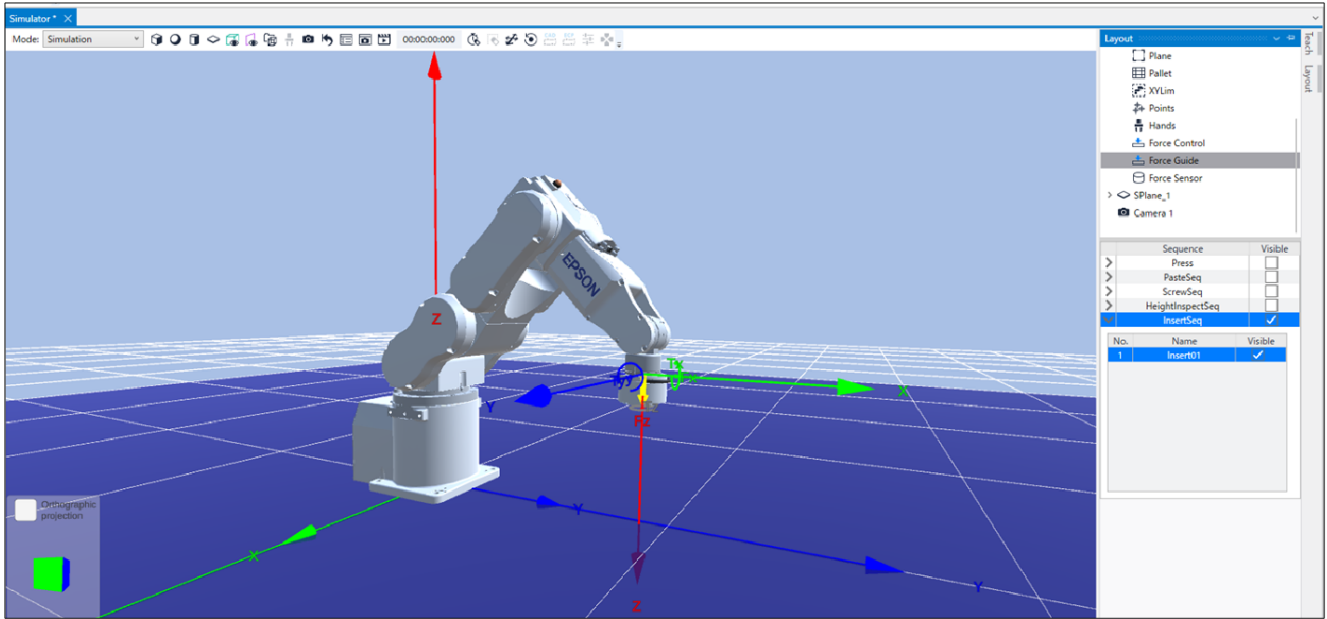

4. Confirm that the yellow arrow's direction is the same as the cylinder insertion direction.
If the direction is different, refer to the following section and check the setting.
Software [Property Setting](#)

4.6.3.4.5 Motion by Force Guidance Function

The following describes how to execute a sequence that performs "Peg In Hole" task in the [Force Guide] window.

1. Open the [Force Guide] window.
2. Click the [Run] button.
Program is compiled and transmitted to the Robot Controller.
If the setting is not correct, an error occurs. Check the settings so far and follow the error message to modify the parameters.

When the program satisfies the conditions set in the properties and can be executed to the end, "✔" is displayed on the upper left of the flowchart and the robot motion stops.

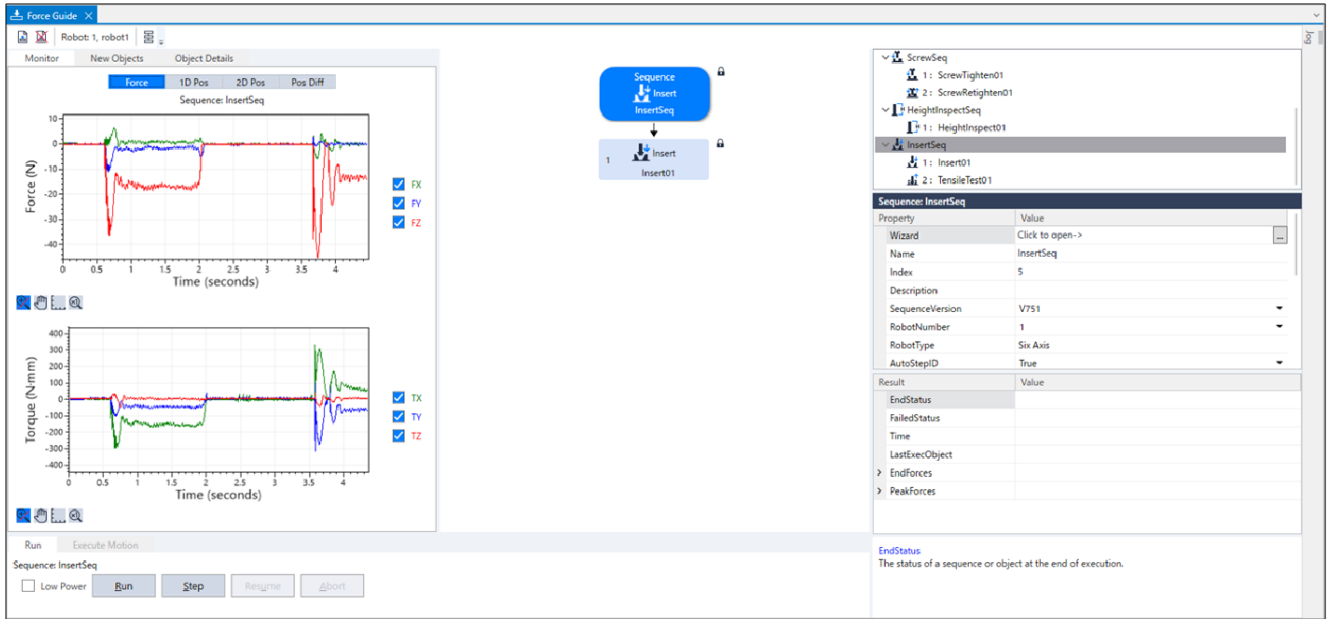

4.6.3.4.6 Return to the Non-Contact State

The following describes how to return to the non-contact state.

Force to perform the Peg In Hole task is still applied even the task is completed.

If you operated an accurate Peg In Hole task such as an interval is tens of microns, large force may be applied even the task is in the end state.

To prevent the robot and the end effector from malfunction or damages, move the robot away from the object immediately after the operation ends, and make sure that no force is applied to the object. If it is obvious that no force is applied to the object, you can omit this step.

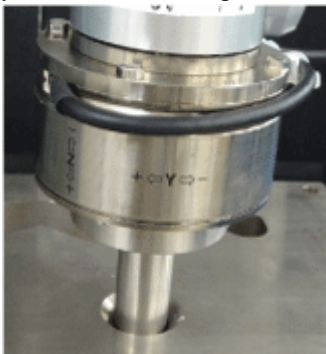

- Operate the jog motion for small distances such as 0.1 mm and set the robot to a non-inserting state.
- Make the cylinder to be non-grasped state.
- Create a force guide sequence that performs "pulling" (press in the opposite direction to the insertion) separately and pull the stick out.

When five minutes have passed after the insertion task, you may not be able to pull the stick out since the detection values shift due to drift of the Force Sensor.

For more details, refer to the following section.

Software: [Advanced Tasks - 2](#)

In this tutorial, pull the stick out by the jog motion while checking on the force monitor.

1. Select Epson RC+ menu-[Tools]-[Force Monitor].

The [Force Monitor] dialog box is displayed.

2. Select the [Start Live] button.
Graph of the currently selected force monitor object is displayed.
3. Display the [Robot Manager] dialog box.
4. Select the [Jog & Teach] panel.
5. Click [Jogging]-[Mode] and select "Tool".
It is a proper setting for removing perpendicular to the hole when the Peg In Hole task is performed to the hole with tilt while performing the follow motion.
6. Select [Short] button on [Jog Distance].
7. Move the robot in the -Z direction 0.1 mm at a time.
Output value will be far from "0" with time due to the drift characteristic of the Force Sensor.
Relative changes of the force value are reflected the contact state changes correctly.
While checking the graph values to be displayed, click the Jog button to move the robot to X, Y direction. The robot will be to non-contact state.
Reference: Software [Resetting the Force Sensor](#)

[Reference]

The [Jog] tab is in the [Force Guide] window. When you select this tab, the [Jog] window is displayed. You can move the robot and set to non-contact state by clicking the Jog button.

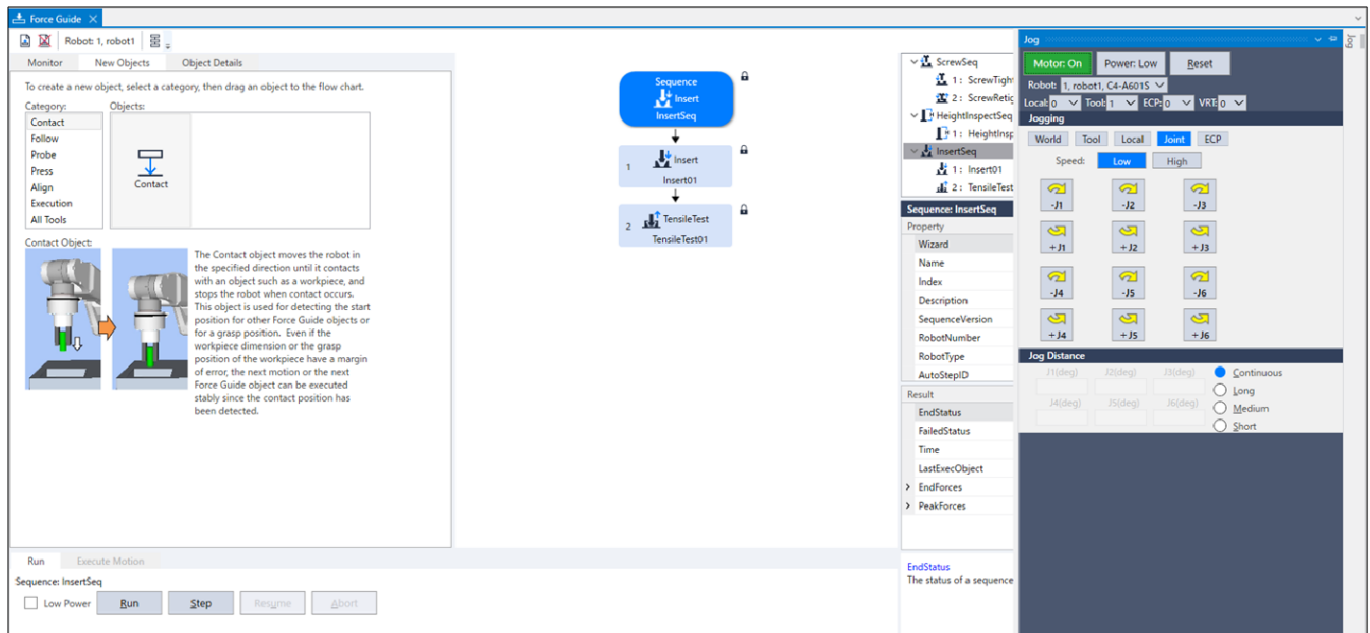

4.6.3.4.7 Motion Analysis by Monitor

The following describes how to use Epson RC+ to check the operation results of a force guide sequence.

1. Open the [Force Guide] window.
2. Click the sequence flow of [InsertSeq].

3. Select the [Monitor] tab.

Select the [Force] tab. Force and position during the [InsertSeq] sequence execution are displayed in the graph.

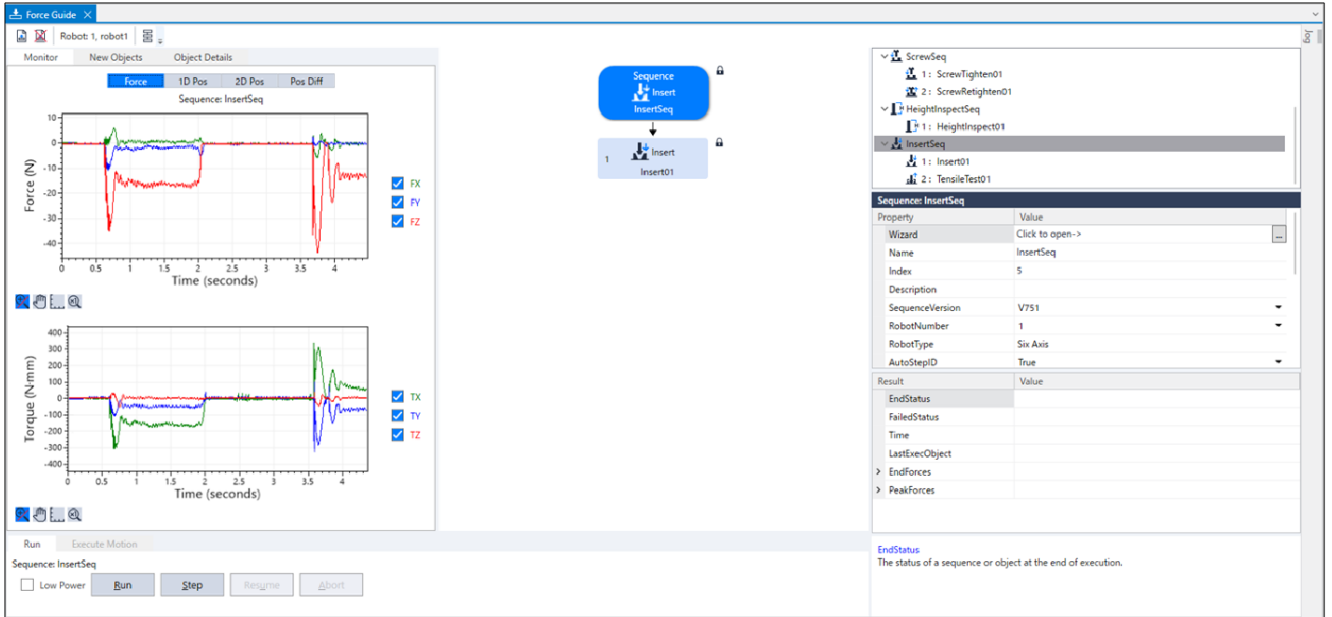

4. Click the object flows of [Step1] to display the force and the position during the execution of the selected force guide object.

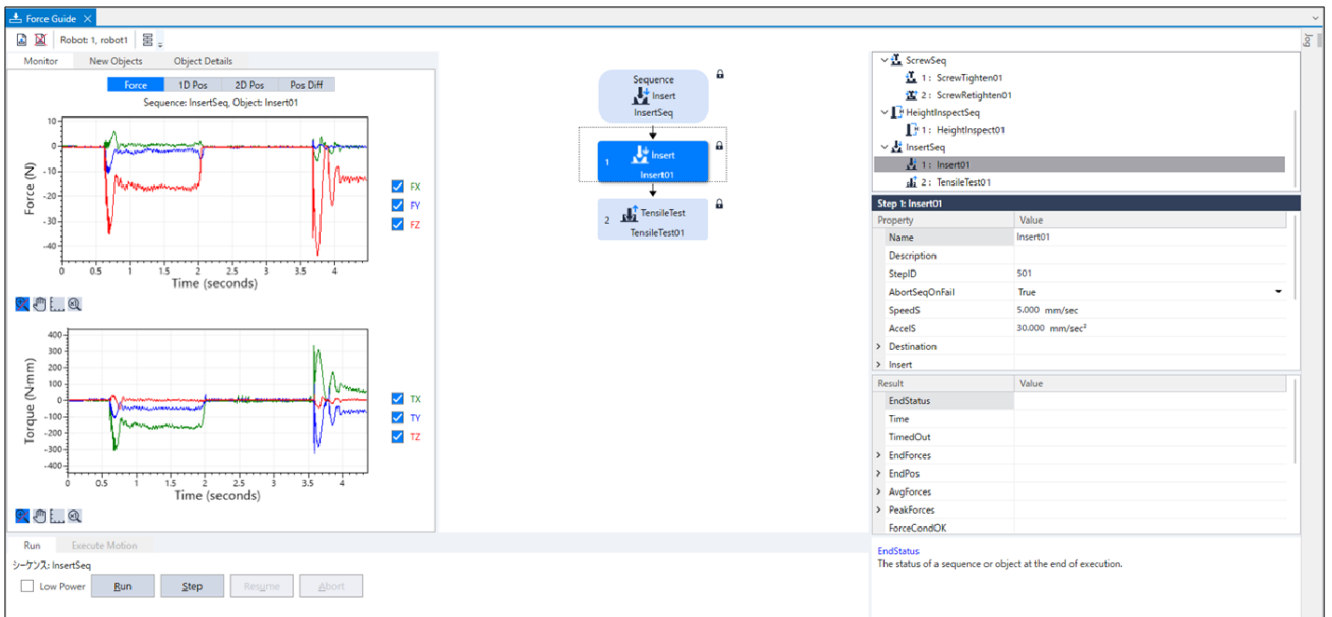

5. Click the sequence flow of [InsertSeq].

Select the [Monitor] tab. Select the [1D Pos] tab.

Graph for analysis is displayed. (horizontal axis: Time, vertical axis: Position)

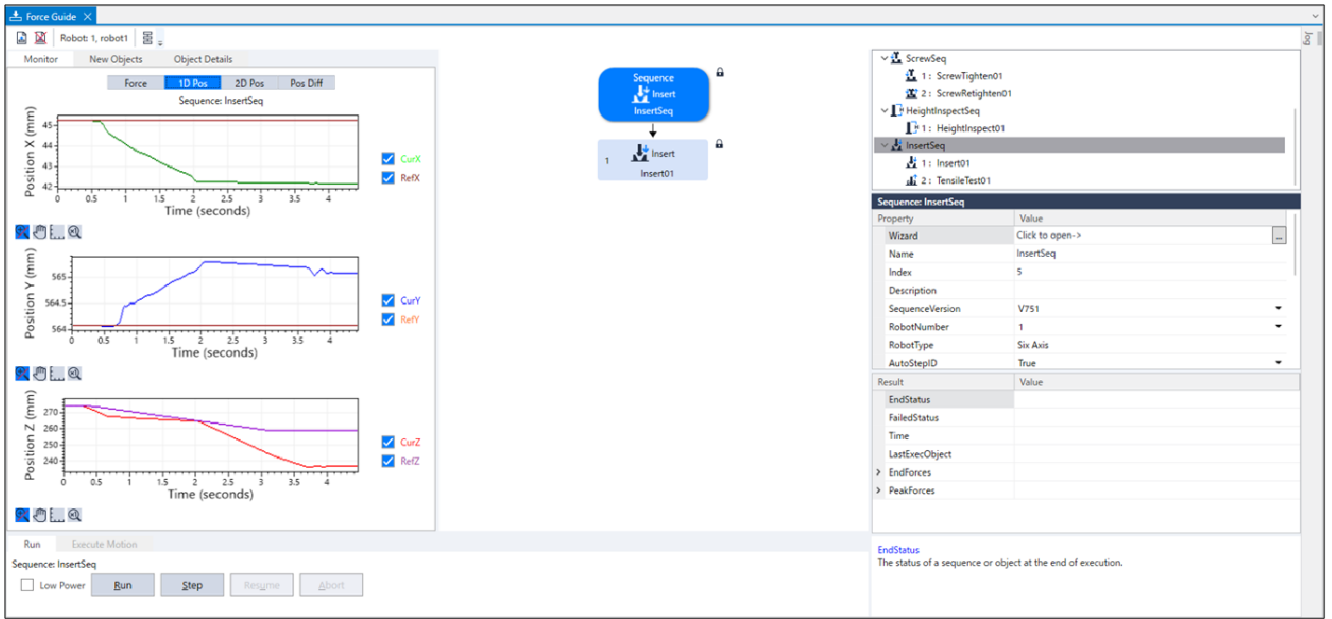

6. Select the [2D Pos] tab.

Graph for analysis is displayed. (horizontal axis, vertical axis: Position)

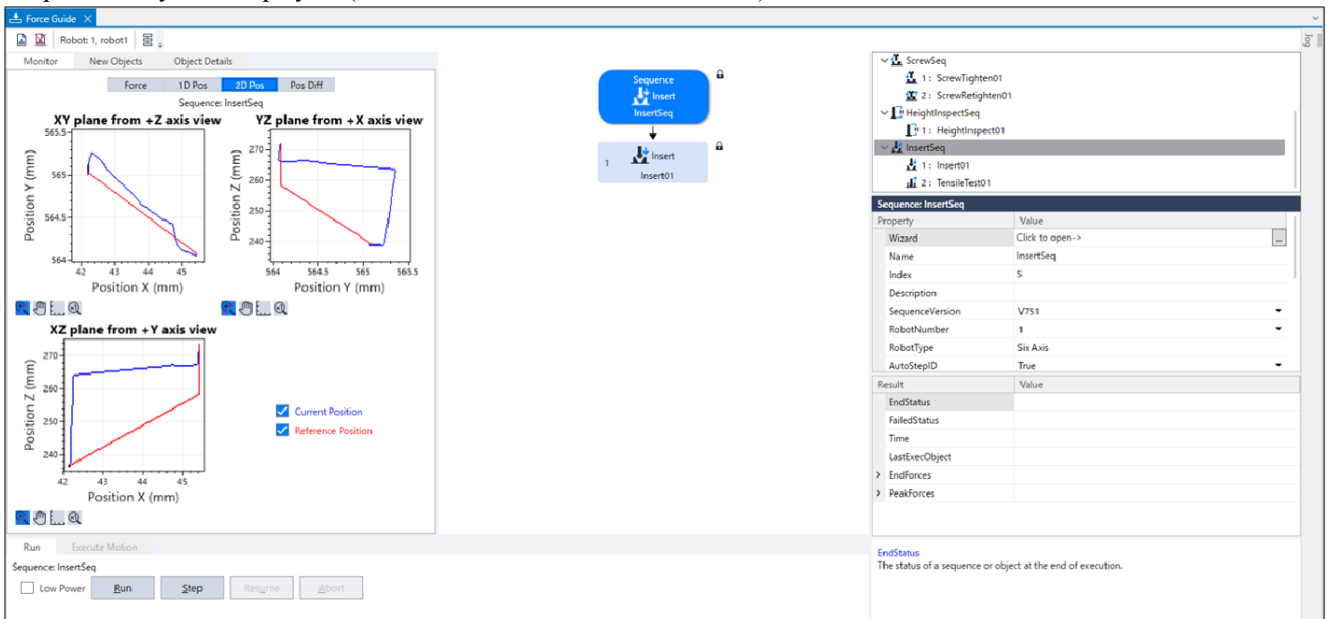

7. Select the [Pos Diff] tab.

Record shifts by force control as relative position changes. It is different from the graph on the [1D Pos] tab.

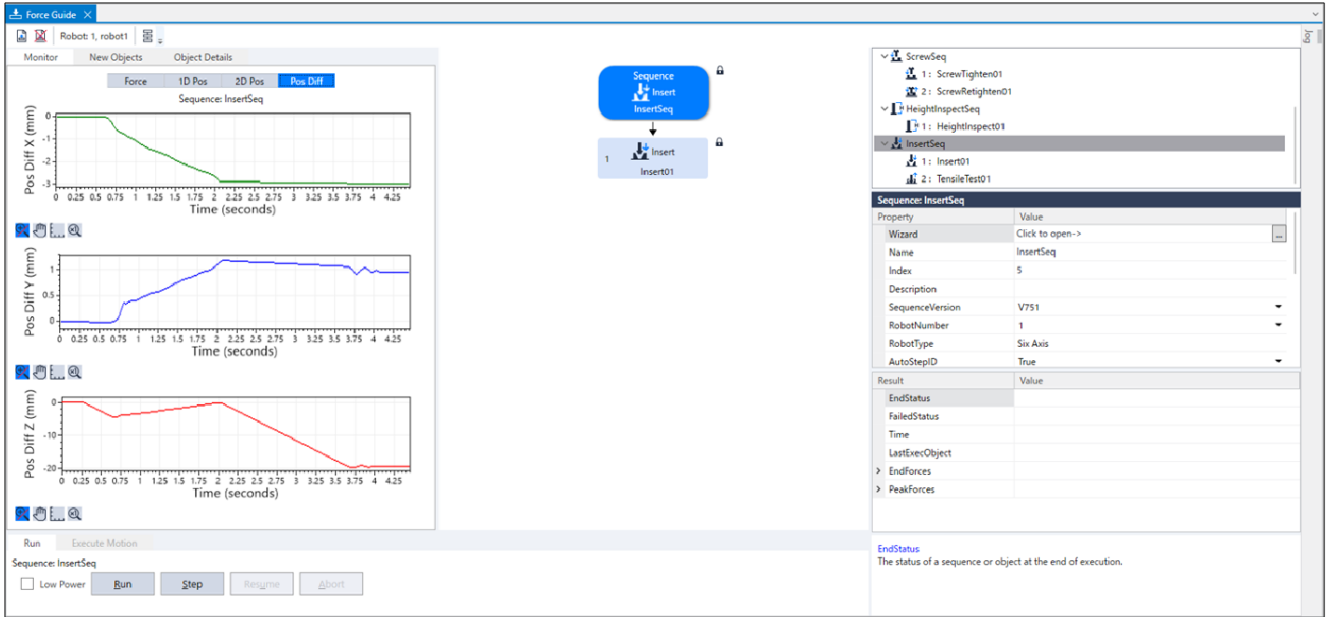

8. Change the unit of the graph and check the changes of force or positions.

9. While watching the monitor shown in this tutorial, check the motion results.

As shown by the red arrow, you can see that the insertion is completed by moving while following the direction other than the insertion direction.

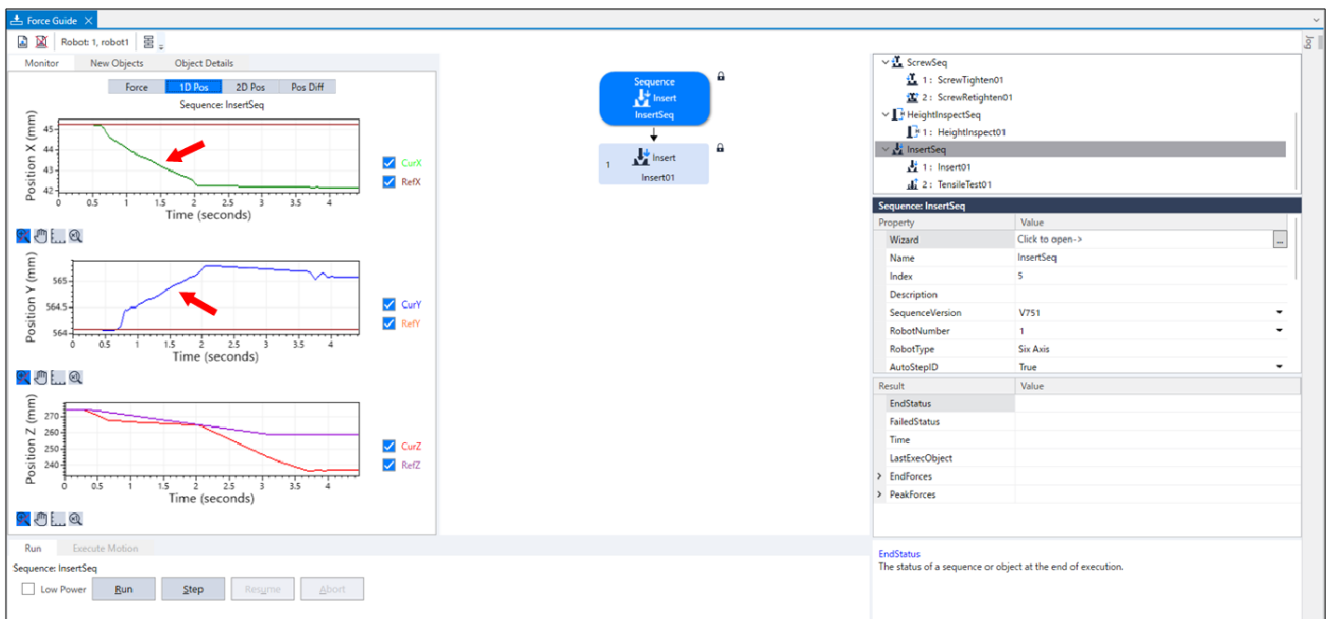

If it is not inserted correctly, the settings may not be correct.

Refer to the following and check the procedures of the tutorial.

- Whether a insertion direction is correct
- Whether the start point is largely moved from a hole
- Whether the settings of the approach distance and the insertion length are correct

4.6.3.4.8 Advanced Tasks

Let's do the following advanced tasks.

1. It takes a long time to perform jog motion for a distance of tens of millimeters, as in "Software [Return to the Non-Contact State.](#)"

Let's try a method to pull the stick out using the force control function right after the Peg In Hole task. At this time, make sure not to reset the Force Sensor by clicking [Sequences]-[Property].

CAUTION

When about five minutes have passed after Peg In Hole task, the robot cannot detect a proper value and fails to pull the stick out due to the drift characteristics of Force Sensor. At this time, a large force will be applied to the workpiece and it may result in damage to workpiece. Be sure to pull the stick out right after the force guide sequence is executed.

If you reset the Force Sensor in the contact state, the force and value at that time will be "0". In this state, the force control function cannot be performed properly and the robot may fail to pull the stick out or the workpiece may get damage. Be sure to set the [ResetSensor] property to "False". Also, when you want to reset the Force Sensor (e.g. click the [Reset Sensor] button or reboot the Controller), move the robot by using the jog motion without performing the force control function and set to the non-insertion state / the non-grasped state.

i. Create another empty force guide sequence which is different from [InsertSeq].

Example: PullFromHole

ii. Add a Press object only and set the properties.

For 6-axis robot, refer to the following settings and adjust the properties such as [Firmness].

- In [Fz_ControlMode], set the "Press- " direction
- Set "Follow" in [Fx_ControlMode], [Fy_ControlMode]
- Set a force of less than 10 N in [Fz_ControlMode]
(If the force is too great, the robot may get caught in the hole.)
- Set a large value in [Timeout] such as 60 sec.
(Robot keeps moving even when the "pulling" task is performed. Click the [Abort] button to stop the robot.)
- Set [FZ_Firmness] to the same value as InsertFirmnessF in [InsertSeq]-[Insert01].
- Set [Fx_Firmness] and [Fy_Firmness] to the same value as FollowFirmnessF in [InsertSeq]-[Insert01].

iii. Click the sequence flow in the flowchart.

iv. Set the [ResetSensor] property to "False".

v. Refer to the following and execute the force control function.

Motion by Force Guidance Function

2. While this tutorial describes a peg in hole procedure, there is a way to check that a workpiece does not come out when pulled in the opposite direction to the direction of insertion when using a workpiece designed to prevent removal when pulled after insertion, such as a connector.

Try this yourself by following the procedure below.

i. Open the [Force Guide] window.

ii. Right click the [InsertSeq] sequence flow, and then click [Sequence Wizard].

The sequence wizard will be displayed.

- iii. Click the [Next] button three times to display the [Step 4: Set insert operation options] dialog box. Change the properties according to the table below. Click the [Next] button six times.

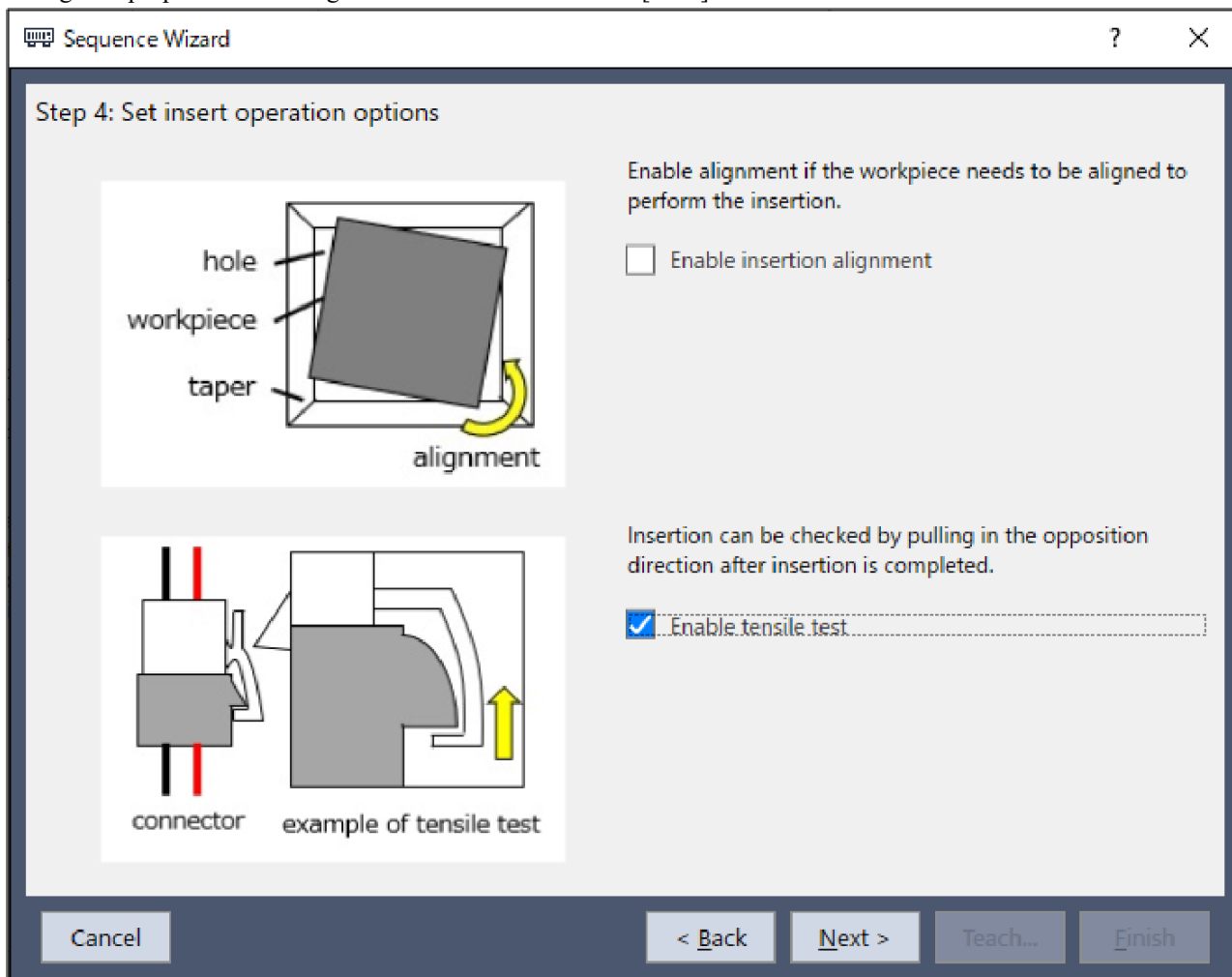

Item	Value	Description
Enable tensile test	Enable	Check insertion by pulling in the opposite direction once insertion is completed.

- iv. The [Step 10: Set tensile test force, range, and duration] dialog box is displayed. Change the following property according to the workpiece in use. This setting does not need to be changed if it can be left at the default value.

Click the [Next] button.

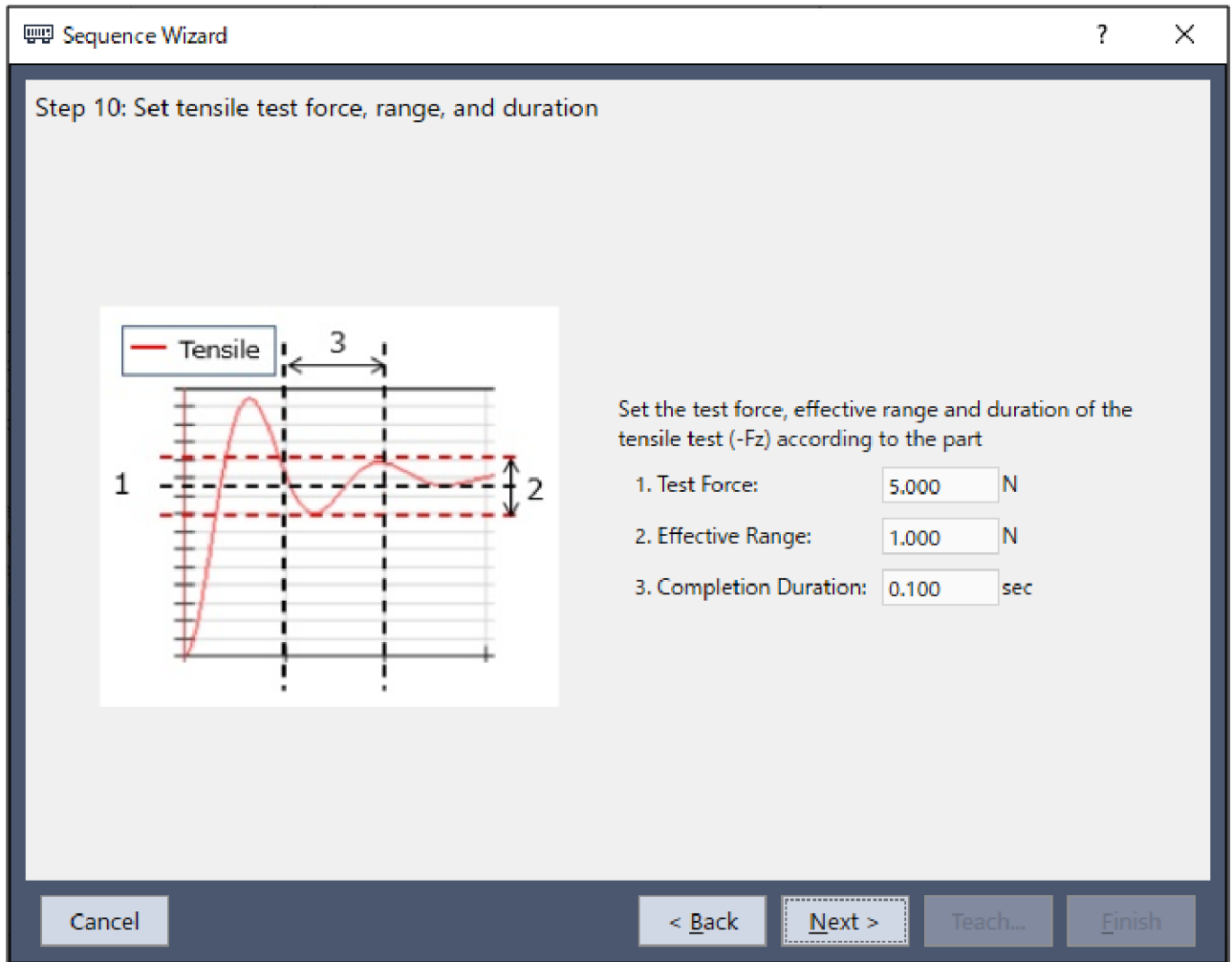

Item	Value	Description
Test Force	5	Set the test pulling force to apply during the tensile test. Set this according to the workpiece in use. This is set to 5 N in this example.
Effective Range	1	This is the effective range for the completion condition to apply regarding the test force. Set the effective range to use for the completion condition for the tensile test. Z axis: Continuous force of 5±1 N applied
Completion Duration	0.1	Set the duration at which completion conditions are deemed to have been met. This is set to 0.1 seconds in this example.

- v. The [Step 11: Set the clearance for the tensile test] dialog box is displayed.
Change the following property according to the workpiece in use.
This setting does not need to be changed if it can be left at the default value.

Click the [Next] button.

Sequence Wizard
?
×

Step 11: Set the clearance for the tensile test

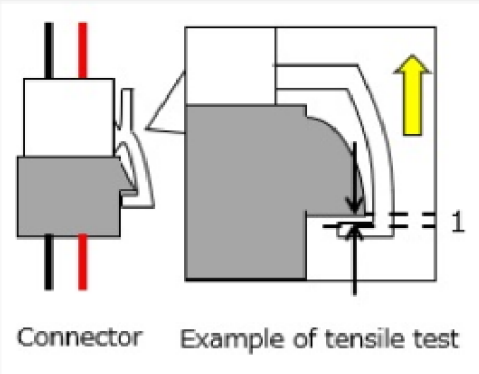

1. Clearance: mm

If the robot moves beyond the allowable amount of clearance during the tensile test, the tensile test will fail and the sequence will be aborted.

Cancel
< Back
Next >
Teach...
Finish

Item	Value	Description
Clearance	1	The clearance range for determining failure when performing a tensile test. Set this according to the workpiece in use. This is set to 1 mm in this example.

- vi. The [Step 12: Set the timeout for the operation] dialog box is displayed.
This setting does not need to be changed from its default value.
Click the [Next] button.



- vii. The [Step 13: Change Summary] dialog box is displayed.
Objects with modified properties, the name of the property, and value changes will appear here.
The following screenshot shows the dialog box that appears when the tensile test is enabled.

If you have changed property values in Steps 10 and 11, those properties will also appear here. Click the [Finish] button.

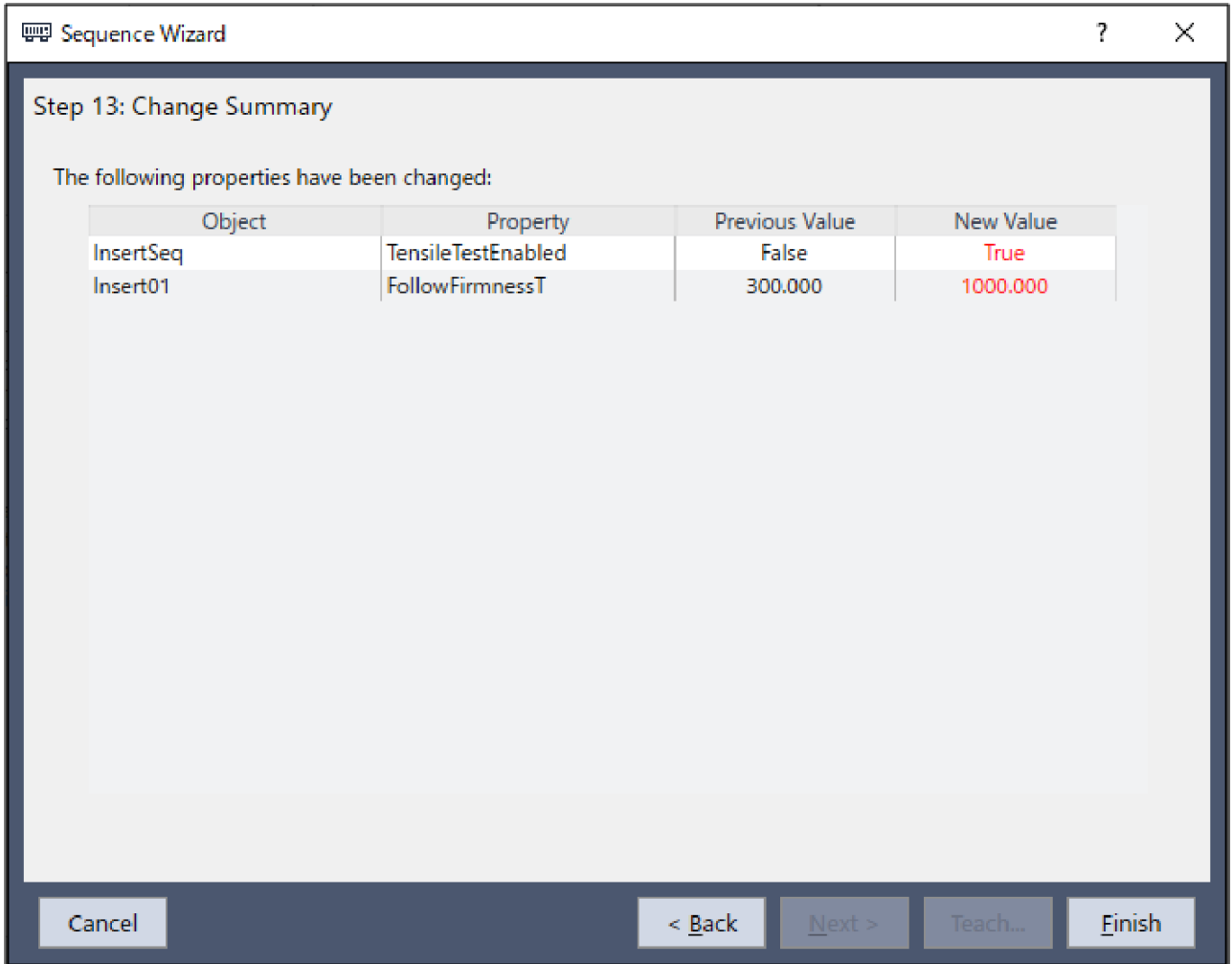

viii. Check that the [TensileTest01] object appears in the [InsertSeq] sequence.

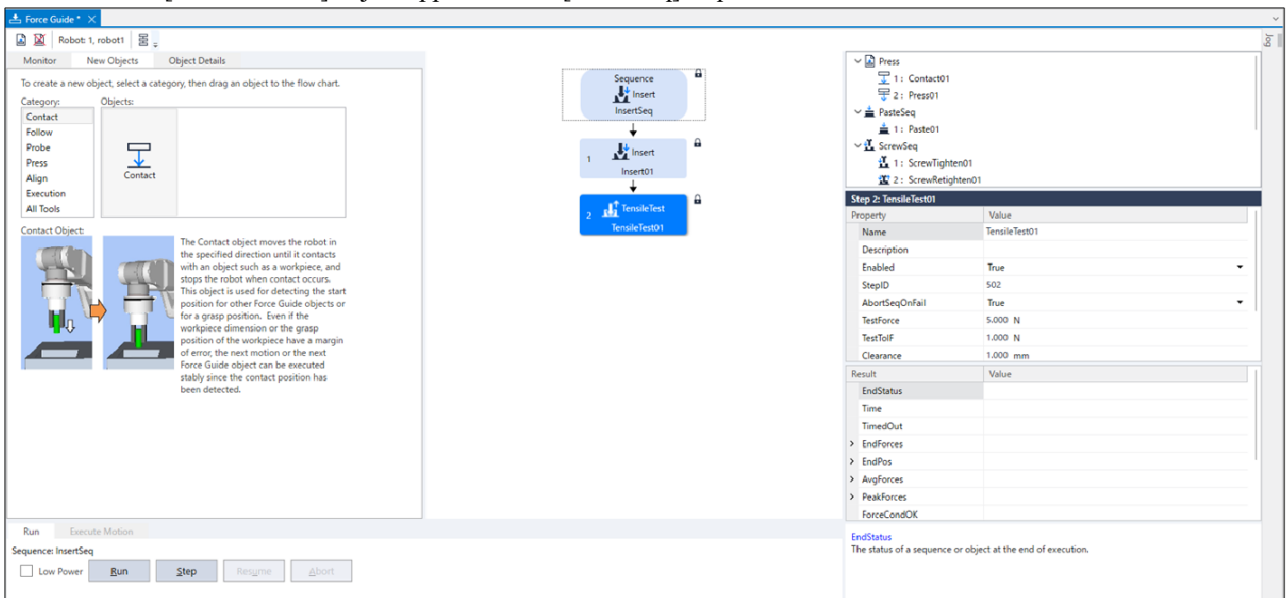

ix. Refer to the following and execute the force control function.

Motion by Force Guidance Function

This ends Insert sequence procedure tutorial.

4.6.4 Command Version (Simple Pressing)

The following describes how to perform a simple pressing by commands.

The pressing operation in this tutorial is that the robot's end effector tip moves to the positive direction of the Tool 0 coordinate system (TLZ), and presses an object for about 10 seconds with applying 20 [N].

The object to be pressed is fixed to a base table and the pressed surface is assumed to a flat metal block.

If the operation is performed with the end effector, ensure that the end effector can withstand a load: 20 [N] in the negative direction of TLZ.

⚠ CAUTION

The parameters described in the example on the following pages are reference values.

This tutorial uses relatively stable parameters, but depending on the operating environment, the operation may not be successful or the motion may be vibratory. Note that adjusting the parameters may be required. note that Slow, stable parameters are used for convenience of explanation. For high-speed operation, adjusting the parameters is required.

4.6.4.1 Creating a Force File

The following describes how to create a force file and add it to the project list.

1. Click Epson RC+ menu-[File]-[New File]. The [New File] dialog box is displayed.

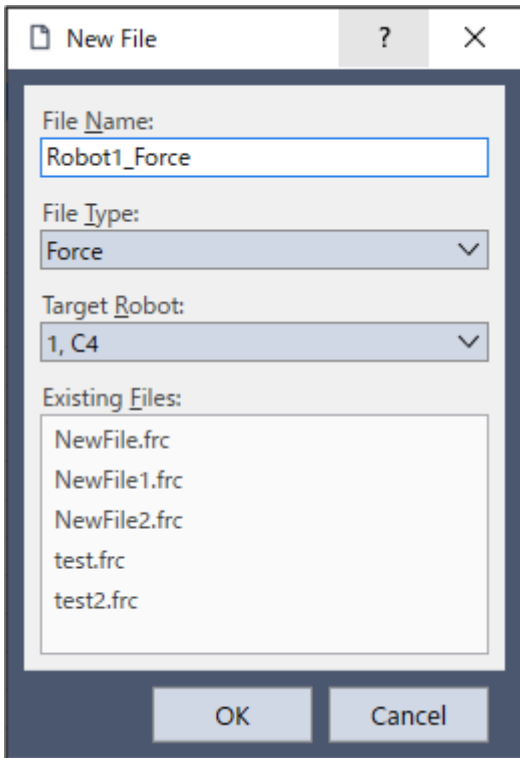

2. Select "Force" in [File Type].
3. Check that the robot is "1".
4. Enter "Robot1_Force" in [File Name].
5. Click the [OK] button.

4.6.4.2 Setting the Force Control Object

The following describes how to set the force control object.

1. Click Epson RC+ menu-[Tools]-[Robot Manager]. The [Robot Manager] dialog box appears.
2. Select the [Force] tab.
3. Select the [Control] tab. The following panel is displayed.

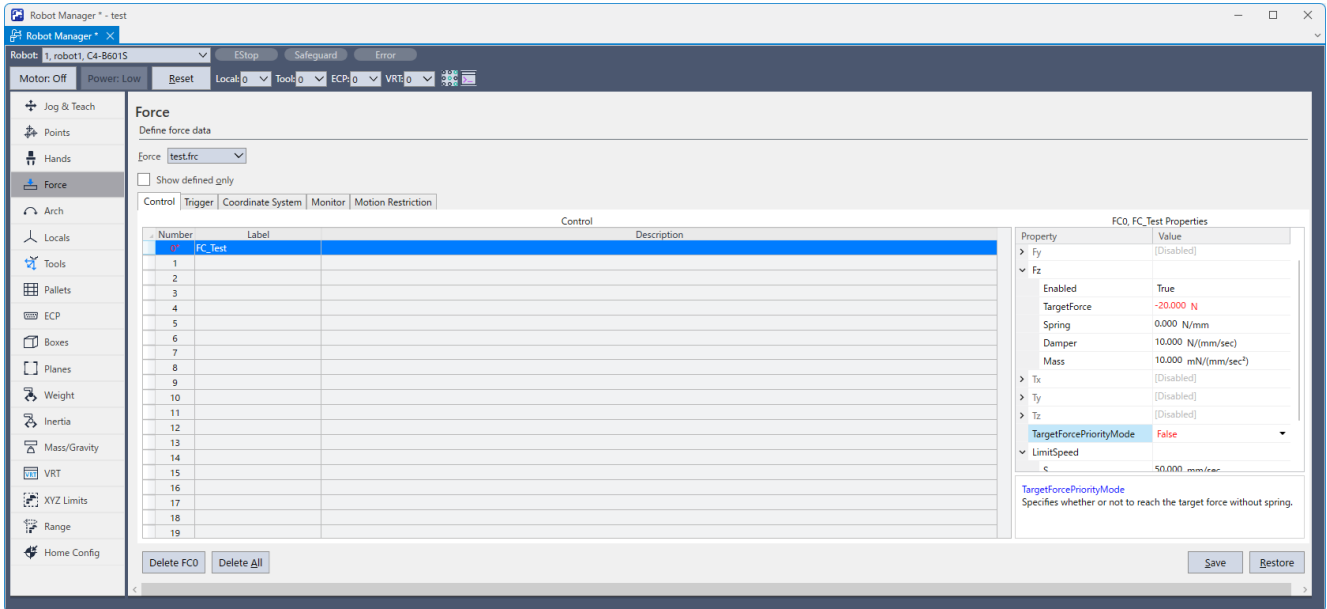

4. Set the following data for force control object "FC1".

Item	Value
Label	FC1_Test
CoordinateSystem	0
Fx_Enabled	False
Fy_Enabled	False
Tx_Enabled	False
Ty_Enabled	False
Tz_Enabled	False
Fz_Enabled	True
Fz_TargetForce	-20
Fz_Spring	0
Fz_Damper	10
Fz_Mass	10
TargetForcePriorityMode	False
LimitSpeedS	50
LimitSpeedR	25

Item	Value
LimitSpeedJ	50
LimitAccelS	200
LimitAccelR	100
LimitAccelJ	100

5. Click the [Save] button.

4.6.4.3 Setting the Force Monitor Object

The following describes how to set the force monitor object.

1. Click Epson RC+ menu-[Tools]-[Robot Manager]. The [Robot Manager] dialog box appears.
2. Select the [Force] tab.
3. Select the [Monitor] tab. The following panel is displayed.

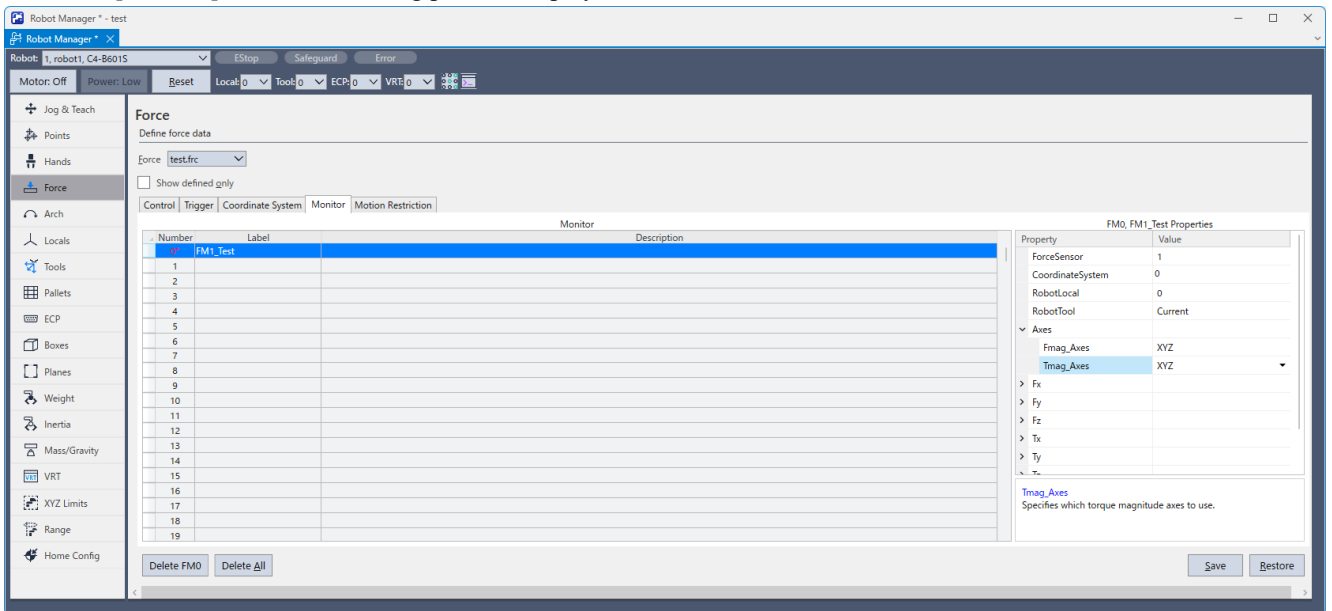

4. Set the following data for force monitor object "FM1".

Item	Value
Label	FM1_Test
ForceSensor	1
CoordinateSystem	0
Fmag_Axes	XYZ
Tmag_Axes	XYZ
Fx-Tmag_LPF_Enabled	False
Fx-Tmag_LPF_TimeConstant	0.01

5. Click the [Save] button.

4.6.4.4 Teaching the Start Point

The following describes how to teach the start position of the "pressing" operation.

1. Click Epson RC+ menu-[Tools]-[Robot Manager]. The [Robot Manager] dialog box appears.
2. Click the [Jog & Teach] tab.

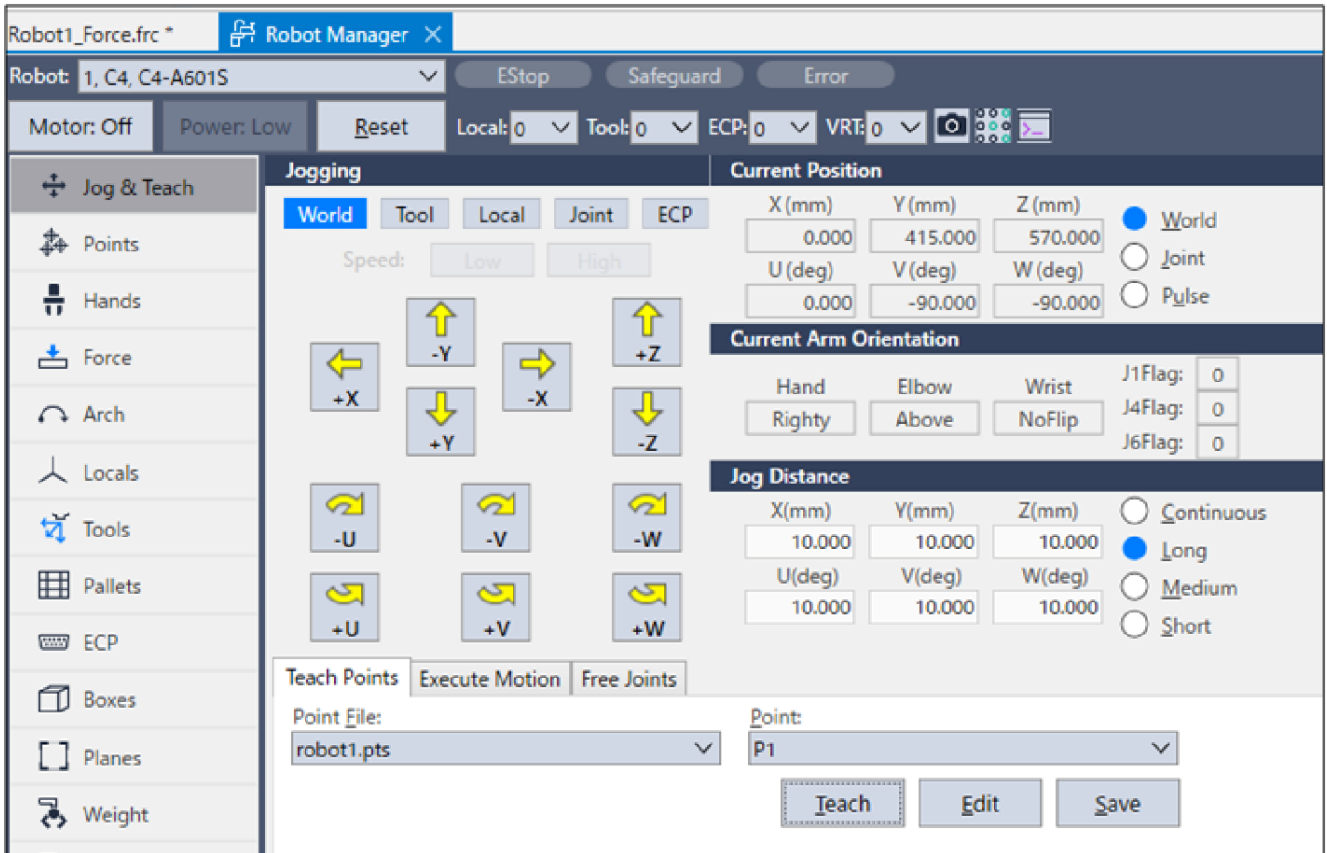

3. Use the Jog button to move the robot so that the Force Sensor or end effector is about 3 mm above the object to be pressed.

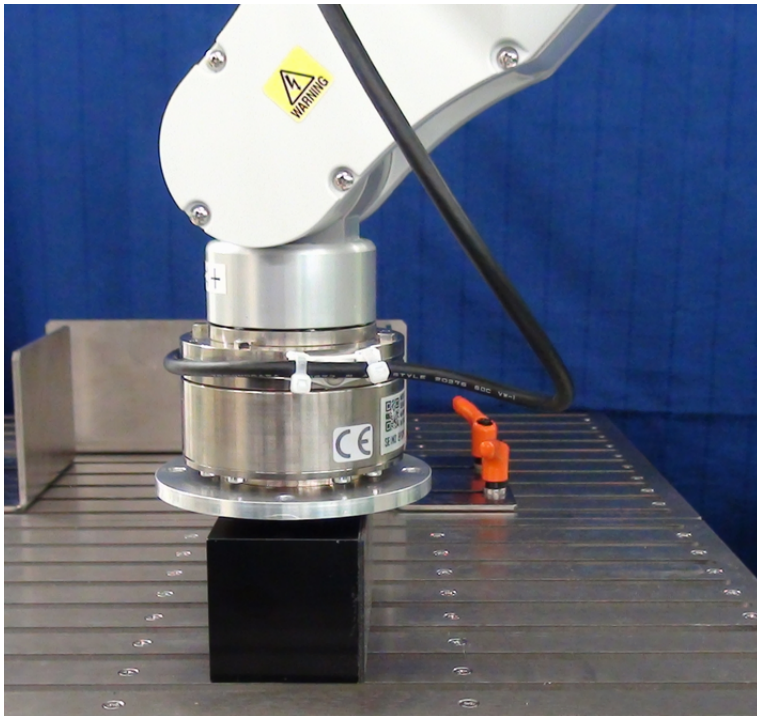

4. Select "P1" in the [Point] dropdown.

- Click the [Teach] button. The following message is displayed.
Confirm the message and click the [Yes] button.

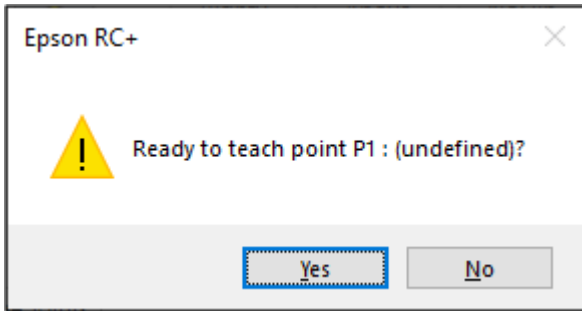

- The [New Point Information] dialog box is displayed. Enter "Test_P1" in [Point Label] and then click the [OK] button.

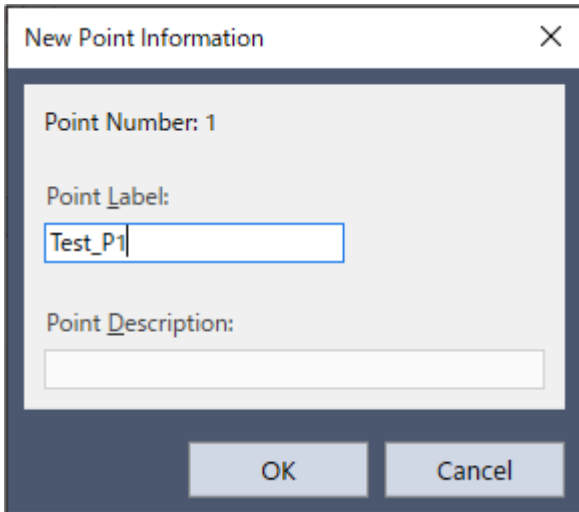

- Click Epson RC+ menu-[File]-[Save All] to save the files.

4.6.4.5 Creating a SPEL+ Program

The following describes how to create a SPEL+ program to perform the "pressing" operation.

- Click Epson RC menu-[File]-[Open File].
The [Open File] dialog box is displayed.

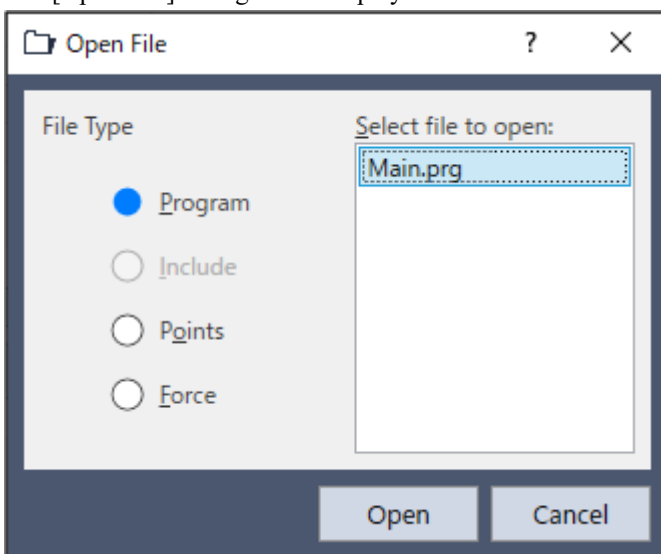

- Select "Program" in [File Type].
- Select "Main.prg" in [Select file to open].

4. Click the [Open] button. The Main.prg screen is displayed.

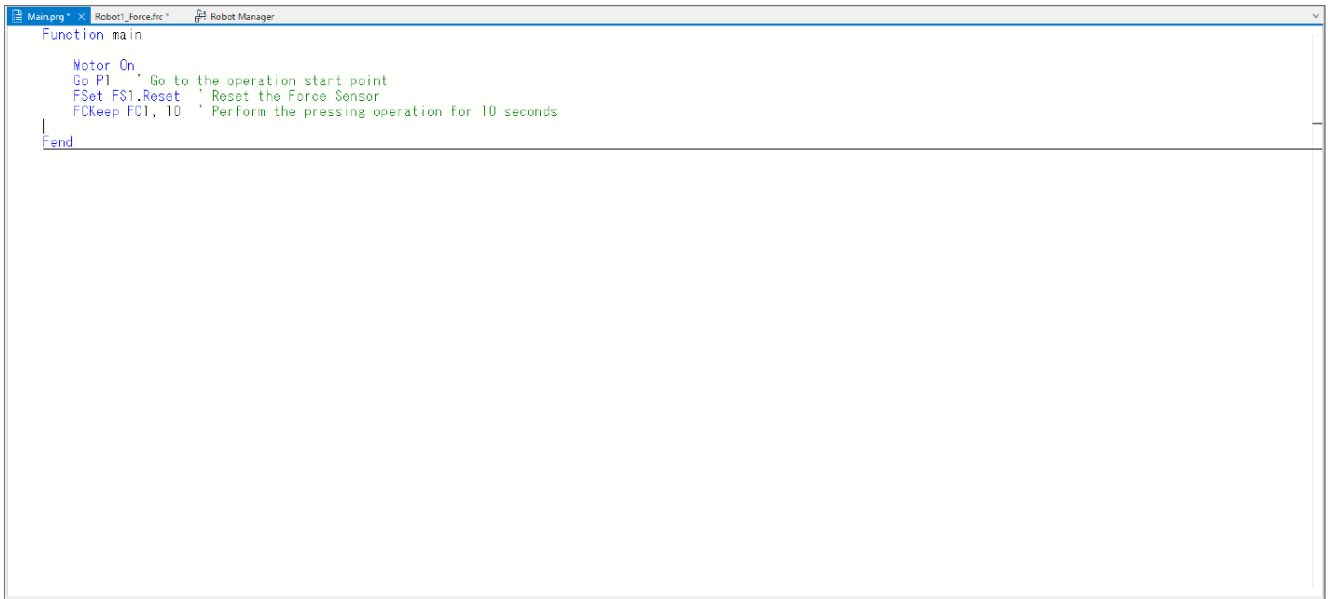

5. Input the following sample program in the main function.

```

Function main
  Motor On
  Go P1      ' Go to the operation start point
  FSet FS1.Reset ' Reset the Force Sensor
  FCKeep FC1, 10 ' Perform the pressing operation for 10 seconds
End
    
```

4.6.4.6 Executing the Force Monitor

To display the force of "pressing" operation on a graph, the following describes how to execute the force monitor.

1. Select Epson RC+ menu-[Tools]-[Force Monitor]. The [Force Monitor] dialog box is displayed.

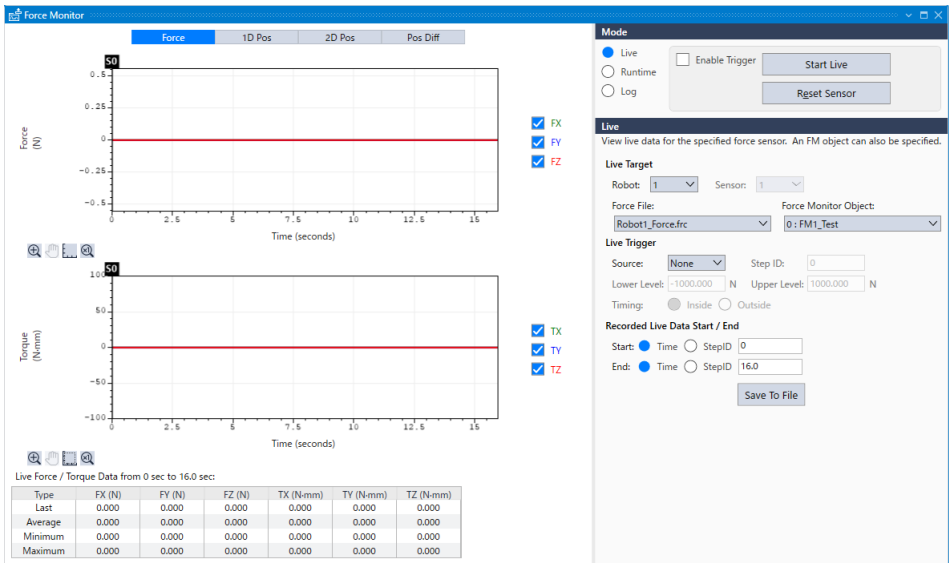

2. Set the following items in [Live].

Item	Value
Robot	1

Item	Value
Force File	Robot1_Force.frc
Force Monitor Object	FM1_Test

3. Select the [Start Live] button. The Force Sensor values are displayed in the graph.

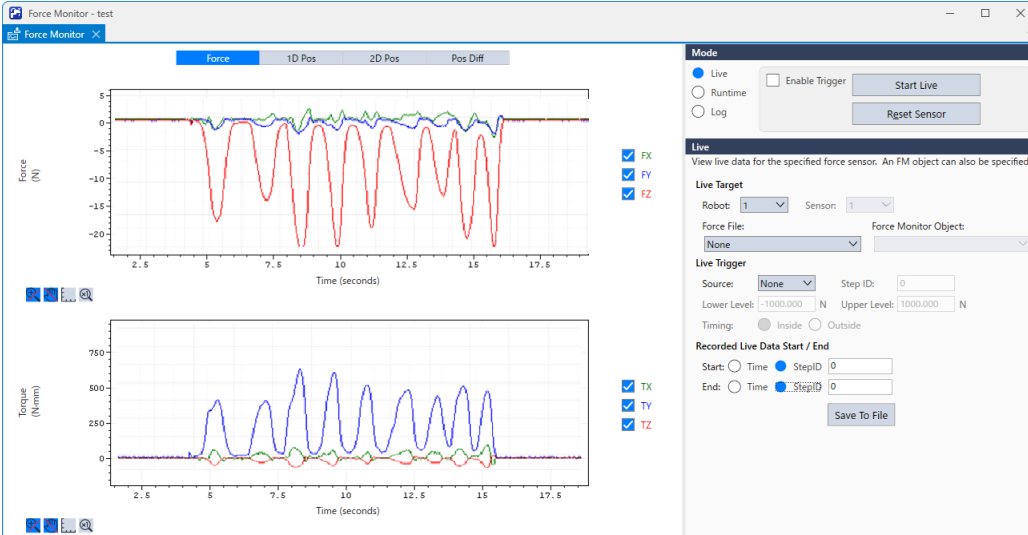

When applying a force in the pressing direction, check that the Fz value changes. If the Fz value does not change and another axis value changes, refer to the following section and check the settings of the force coordinate system.

Software **Force Sensor Correction**

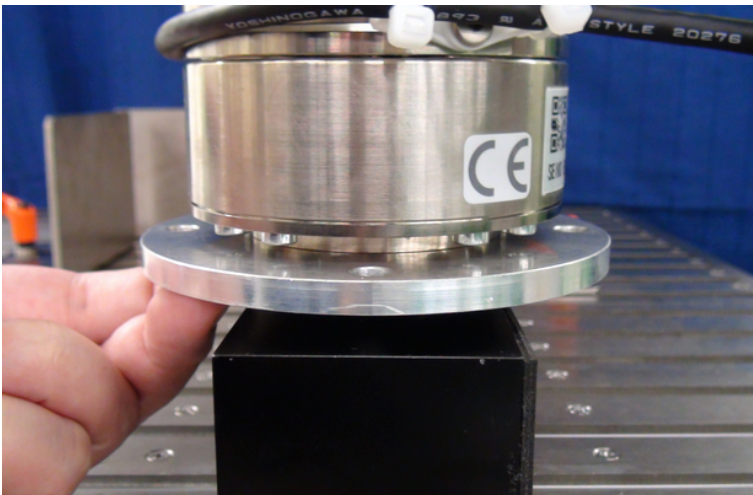

⚠ CAUTION

When entering the safe guarded area in order to apply a force to the Force Sensor, ensure safety by safety measures such as setting the Manipulator to operation-prohibited status.

For details of safety, refer to the following manual.

"Epson RC+ 8.0 User's Guide"

4.6.4.7 Executing the SPEL+ Program

The following describes how to execute the SPEL+ program to perform the "pressing" operation.

1. Click Epson RC+ menu-[Run]-[Run Window]. The [Run] window is displayed. Build the project and the program and project file are sent to the Controller. If an error does not occur while performing the build, the [Run] window is displayed.

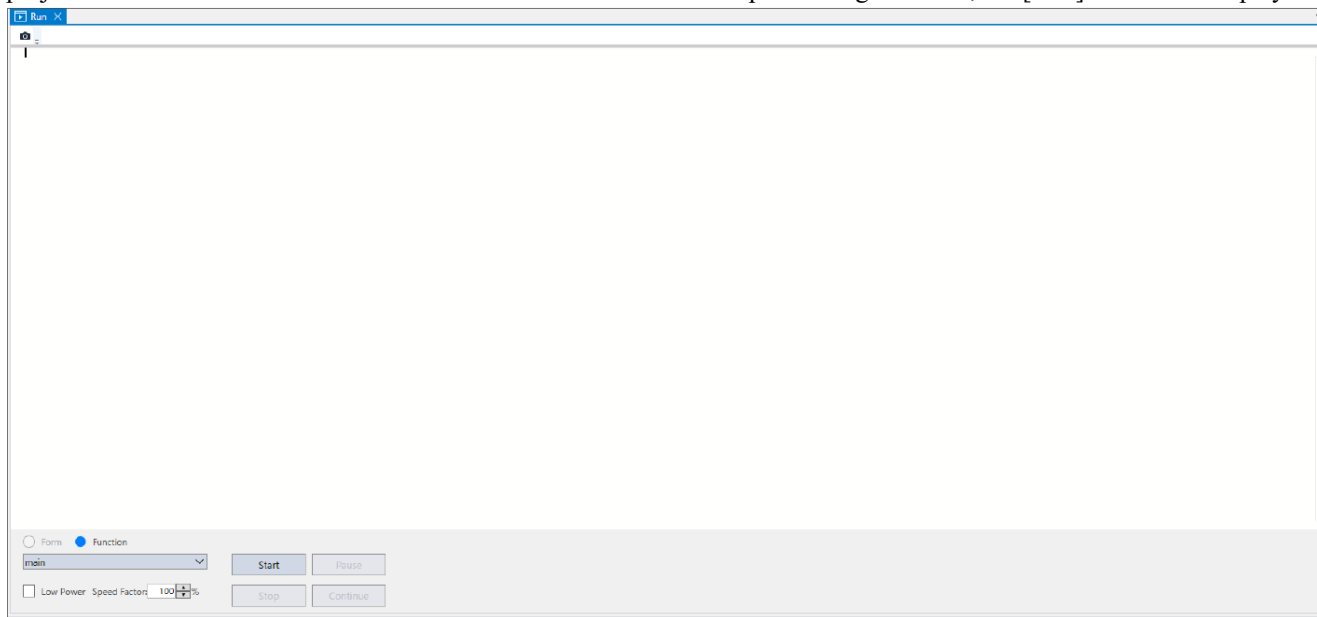

2. Click the [Start] button to run the program. The robot starts the "pressing" operation when the program is executed. You can check that the force is set to 20 N on the graph of the [Force Monitor] dialog box.

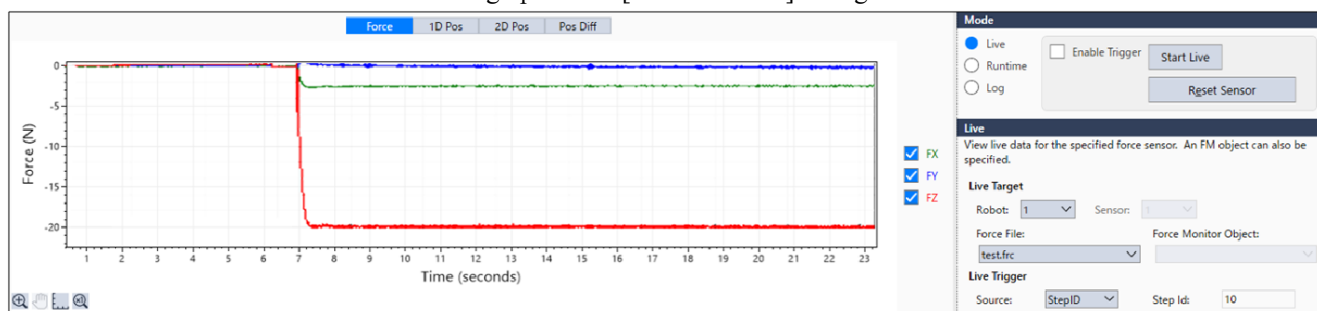

4.7 Troubleshooting

4.7.1 The Force Sensor is not recognized

Refer to the following section and check the wiring.

Hardware [Connection Example](#)

Pay particular attention to the following items.

- Force Sensor Cable
- Force Sensor M/I Cable
Check the hardware connections and then refer to the following section and enable the Force Sensor.
Software [Checking the Connection](#)

4.7.2 The output value of the Force Sensor differs from the actual force direction

Refer to the following section and check the coordinate system.

Installation [Robot local](#)

All of the following items impact the Force coordinate system.

- Settings of the Base, Local, and Tool coordinates
- Setting of FlangeOffset
- Setting of the force coordinate object (FCS#)

4.7.3 The output value of the Force Sensor differs from the actual force

The output of the force and torque when the Force Sensor is reset is set as "0" for the Force Sensor. Therefore, if an external force is being applied when the Force Sensor is reset, the Force Sensor detects a force even if no force is actually applied after the external force is removed. To avoid this, reset the Force Sensor when no external force is being applied. Also, weight of the Force Sensor is applied depending of the robot posture since the detection position is located at the center of the Force Sensor structure.

Furthermore, if the posture of the Force Sensor changes from that when the Force Sensor is reset, the output value of the Force Sensor also changes due to the effect of gravity. If the posture of the Force Sensor does not change in the operation using the force functions (force control, force trigger, and force monitor), reset the Force Sensor immediately before using the force functions.

If the posture changes during executing of the force functions, the effect of gravity can be reduced by using gravity compensation. For the details, refer to the following section.

Software [Gravity Compensation](#)

4.7.4 The output value of the Force Sensor changes over time.

Epson Force Sensor has drift characteristics. If the change is within the range of the time drift described in the following section, it is normal.

Hardware [Specification](#)

To avoid the effect of the time drift, reset the Force Sensor immediately before using the force functions. Use the force functions within 10 minutes after resetting the Force Sensor.

4.7.5 Abnormality occurs on the Force Sensor

If an error regarding the Force Sensor occurs, refer to the following manual and take measures against the error.
"Epson RC+ 8.0 SPEL+ Language Reference" - SPEL+ Error Messages

If the Force Sensor is used for a long time without being reset, an error accumulates due to the drift. This may result in an element error of the Force Sensor. If the error occurs, executes the Reboot property of the force sensor object.

Furthermore, accuracy abnormality of the Force Sensor may occur when the Force Sensor is hit against the peripherals or when an error occurs on the Force Sensor. In this case, check that the Force Sensor is working properly. For the details, refer to the following section.

Software [Checking the Accuracy of the Force Sensor](#)

4.7.6 You cannot perform the intended motion by the force guide object(s)

For the motions by the force guide object(s), if you cannot perform the intended motions (e.g. larger force than expected is applied), refer to the following section and adjust properties.

- Software [General force guide object](#)
Adjustment guidelines for each general force guide object described in 4.2.2.1 to 4.2.2.10
- Software [Adjustment Guidelines for the Paste sequence and Object Property Values](#)
- Software [Adjustment Guideline for ScrewTighten Sequence and Object Property Values](#)
- Software [Adjustment Guidelines for the HeightInspect Sequence and Object Property Values](#)
- Software [Adjustment Guidelines for the Insert Sequence and Object Property Values](#)

4.7.7 An error 5546 occurs

An error 5546 may occur when executing the Reset property while vibrations from an external device are applied to the Force Sensor. If the vibration is intermittent, this error can be avoided by specifying "FG_RESET_WAIT_VIBRATION" in the Reset property.

In addition to receiving an error 5546, environments where a continuous vibration is applied may also adversely impact the accuracy of the force control function. Place a rubber sheet on the legs of the system to eliminate any external vibrations the robot may be subjected to.

4.7.8 The robot moves in the opposite direction to the intended direction

Epson's Force Sensor is a sensor that senses the application of force. Note that the direction between the robot motion direction and the pressing force/detection force to be set are always opposite.

For example, if you specify Press+ (pressing to the positive direction) in Fx_ControlMode of the Press object, you need to set a negative value to Fx_PressForce. The force recorded as the motion result will also be a negative value.

This also applies for the force control function using a ForceControl object. To move and press the robot in the +Fx direction, you will need to set a negative value to Fx_TargetForce.

4.7.9 Contact takes too long

The robot's speed of motion needs to be reduced to keep within overshoot limits when making contact. This may result in worse cycle times.

If this happens, set the approach point for commencing the contact motion close to the contact point to reduce contact times. However, it is important to set a point that avoids collisions while traveling to the approach point, considering variations in the workpieces used.

When executing the contact motion using Till FT, this issue can be improved by setting FG_SOFT_STOP in TillStopMode.

4.7.10 The robot does not reach the destination

When executing Move or another operation command with the force control function enabled for a specific direction only, the axis may not be able to reach its destination if the force control function is disabled for the axis. This occurs when the LimitSpeedSRJ property and the LimitAccelSRJ property in the force control object restricts the speed and acceleration required for movement.

You can check speed and acceleration restrictions with the MotionLimited status.

If restrictions apply, increase the LimitSpeedSRJ property and the LimitAccelSRJ property to ensure unrestricted movement, and allow the axis to reach its destination. Note, however, that the force control function increases the speed and acceleration in proportion with the force applied. Make sure to adjust these settings within the tolerable range.

If this cannot be adjusted using the LimitSpeedSRJ property and the LimitAccelSRJ property, reduce the SpeedS and AccelS properties specified for Move or another operation command, to ensure unrestricted movement, and allow the axis to reach its destination.

Low power restrictions will automatically limit the LimitSpeedSRJ property and the LimitAccelSRJ property when in low power mode. If increasing the LimitSpeedSRJ property and the LimitAccelSRJ property settings will have no effect, check whether the system is in low power mode.

4.7.11 The robot bounces excessively when pressing

If the LimitSpeedSRJ property and the LimitAccelSRJ property values are small, the speed and acceleration required will be limited, and the robot may bounce excessively when moving in reaction to the force applied.

If this happens, increase the LimitSpeedSRJ property and the LimitAccelSRJ property settings.

Low power restrictions will automatically limit the LimitSpeedSRJ property and the LimitAccelSRJ property when in low power mode. If increasing the LimitSpeedSRJ property and the LimitAccelSRJ property settings will have no effect, check whether the system is in low power mode.

4.7.12 Certain properties do not appear

Properties not supported by the version of the controller firmware in use will not appear. Try updating your controller firmware.