

EPSON

Industrial Robot: SCARA Robots GX series Manual

Original instructions

©Seiko Epson Corporation 2021-2024

Rev.10
ENM247R6540F

Table of Contents

- 1. Introduction 11**
- 1.1 Introduction 12
- 1.2 Trademarks 12
- 1.3 Terms of Use 12
- 1.4 Manufacturer 12
- 1.5 Contact Information 12
- 1.6 Disposal 13
- 1.7 Before Use 13
- 1.8 Manual Types for This Product 13
- 2. GX4 Manipulator 15**
- 2.1 Safety 16
- 2.1.1 Conventions Used in This Manual 16
- 2.1.2 Design and Installation Safety 17
- 2.1.2.1 Strength of the Ball Screw Spline 17
- 2.1.3 Operation Safety 18
- 2.1.4 Emergency Stop 19
- 2.1.5 Safeguard (SG) 20
- 2.1.6 Arm Movement Method in the Emergency Stop State 21
- 2.1.7 ACCELS Setting for CP Motion 22
- 2.1.8 Warning Labels 24
- 2.1.8.1 Warning Labels 24
- 2.1.8.2 Information Labels 24
- 2.1.8.3 Labelled Locations 25
- 2.1.9 Responses for Emergencies or Malfunctions 27
- 2.1.9.1 When a Collision with the Manipulator Occurs 27
- 2.1.9.2 Entanglement with the Manipulator 27
- 2.2 Specifications 29
- 2.2.1 Model Name GX4-A 29
- 2.2.2 Model Name GX4-B 33
- 2.2.3 Model Name GX4-C 36

2.2.4 Names of Parts and Their Dimensions	39
2.2.4.1 Table Top Mounting Specifications	39
2.2.4.1.1 Cable Mounting Direction: Standard	39
2.2.4.1.2 Cable Mounting Direction: Cable Routing from Bottom Side	46
2.2.4.2 Multiple Mounting Specifications	52
2.2.5 Specifications Table	58
2.2.6 How to Set the Model	58
2.3 Environment and Installation	59
2.3.1 Environment	59
2.3.2 Base Table	60
2.3.3 Manipulator Mounting Dimensions	62
2.3.4 From Unpacking to Installation	64
2.3.4.1 Safety Information for the Flow from Unpacking to Installation	64
2.3.4.2 Table Top Mounting Specifications	65
2.3.4.3 Multiple Mounting Specifications	67
2.3.4.4 Cleanroom & ESD Specifications	69
2.3.5 Connecting the Cables	70
2.3.6 User Wires and Pneumatic Tubes	73
2.3.6.1 Electrical Wires	73
2.3.6.2 Pneumatic Tubes	73
2.3.7 Relocation and Storage	77
2.3.7.1 Safety Information for Relocation and Storage	77
2.3.7.2 Table Top Mounting Specifications	78
2.3.7.3 Multiple Mounting Specifications	81
2.4 Setting the Hand	84
2.4.1 Installing the Hand	84
2.4.2 Attaching Cameras and Valves	85
2.4.3 Weight and Inertia Settings	87
2.4.3.1 Weight Setting	87
2.4.3.1.1 Weight of Load Attached to Shaft	88
2.4.3.1.2 Weight of Load Attached to Arm	88
2.4.3.1.3 Automatic Speed Correction at Weight Setting	89
2.4.3.1.4 Automatic Acceleration/Deceleration Correction at Weight Setting	90
2.4.3.2 Inertia Setting	92
2.4.3.2.1 Moment of Inertia and Inertia Setting	92

2.4.3.2.2 Moment of Inertia of Load Attached to Shaft	93
2.4.3.2.3 Automatic Acceleration/Deceleration Correction of Joint #4 at Inertia (Moment of Inertia) Setting	94
2.4.3.2.4 Eccentricity and Inertia Setting	94
2.4.3.2.5 Eccentricity of Load Attached to Shaft	95
2.4.3.2.6 Automatic Acceleration/Deceleration Correction at Inertia (Eccentricity) Setting	95
2.4.3.2.7 Calculating the Moment of Inertia	96
2.4.4 Safety Information for Auto Acceleration of Joint #3	97
2.4.4.1 Automatic Acceleration/Deceleration Correction by Shaft Position	97
2.5 Work Envelope	99
2.5.1 Work Envelope Setting by Pulse Range	100
2.5.1.1 Joint #1 Maximum Pulse Range	100
2.5.1.2 Joint #2 Maximum Pulse Range	102
2.5.1.3 Joint #3 Maximum Pulse Range	104
2.5.1.3.1 Joint #4 Maximum Pulse Range	104
2.5.2 Setting the Work Envelope by Mechanical Stops	105
2.5.2.1 Setting the Mechanical Stops of Joints #1 and #2	106
2.5.2.2 Setting the Mechanical Stop of Joint #3	110
2.5.3 Setting the Rectangular Range in the XY Coordinate System of the Manipulator	112
2.5.4 Standard Work Envelope	113
3. GX8 Manipulator	118
3.1 Safety	119
3.1.1 Conventions Used in This Manual	119
3.1.2 Design and Installation Safety	120
3.1.2.1 Strength of the Ball Screw Spline	120
3.1.3 Operation Safety	121
3.1.4 Emergency Stop	122
3.1.5 Safeguard (SG)	122
3.1.6 Arm Movement Method in the Emergency Stop State	123
3.1.7 ACCELS Setting for CP Motion	125
3.1.8 Warning Labels	126
3.1.8.1 Warning Labels	126
3.1.8.2 Information Labels	126
3.1.8.3 Labelled Locations	127

3.1.9 Responses for Emergencies or Malfunctions	128
3.1.9.1 When a Collision with the Manipulator Occurs	128
3.1.9.2 Entanglement with the Manipulator	128
3.2 Specifications	130
3.2.1 Model Name GX8-A	130
3.2.2 Model Name GX8-B	137
3.2.3 Model Name GX8-C	144
3.2.4 Names of Parts and Their Dimensions	150
3.2.4.1 Table Top Mounting Specifications	150
3.2.4.1.1 Cable Mounting Direction: Standard	150
3.2.4.1.2 Cable Mounting Direction: Cable Routing from Bottom Side	159
3.2.4.2 Wall Mounting Specifications	167
3.2.4.3 Ceiling Mounting Specifications	176
3.2.5 Specifications Table	185
3.2.6 How to Set the Model	185
3.3 Environment and Installation	185
3.3.1 Environment	185
3.3.2 Base Table	187
3.3.3 Manipulator Mounting Dimensions	189
3.3.4 From Unpacking to Installation	192
3.3.4.1 Safety Information for the Flow from Unpacking to Installation	192
3.3.4.2 Table Top Mounting Specifications	195
3.3.4.3 Wall Mounting Specifications	197
3.3.4.4 Ceiling Mounting Specifications	199
3.3.4.5 Cleanroom & ESD-Model	201
3.3.4.6 Protected-Model	201
3.3.5 Connecting the Cables	202
3.3.6 User Wires and Pneumatic Tubes	205
3.3.6.1 Electrical Wires	205
3.3.6.2 Pneumatic Tubes	206
3.3.7 Relocation and Storage	209
3.3.7.1 Safety Information for Relocation and Storage	209
3.3.7.2 Table Top Mounting Specifications	210
3.3.7.3 Wall Mounting Specifications	213
3.3.7.4 Ceiling Mounting Specifications	217

3.4 Setting the Hand	220
3.4.1 Installing the Hand	220
3.4.2 Attaching Cameras and Valves	221
3.4.3 Weight and Inertia Settings	224
3.4.3.1 Weight Setting	224
3.4.3.1.1 Weight of Load Attached to Shaft	225
3.4.3.1.2 Weight of Load Attached to Arm	225
3.4.3.1.3 Automatic Speed Correction at Weight Setting	226
3.4.3.1.4 Automatic Acceleration/Deceleration Correction at Weight Setting	228
3.4.3.2 Inertia Setting	230
3.4.3.2.1 Moment of Inertia and Inertia Setting	230
3.4.3.2.2 Moment of Inertia of Load Attached to Shaft	231
3.4.3.2.3 Automatic Acceleration/Deceleration Correction of Joint #4 at Inertia (Moment of Inertia) Setting	231
3.4.3.2.4 Eccentricity and Inertia Setting	232
3.4.3.2.5 Eccentricity of Load Attached to Shaft	232
3.4.3.2.6 Automatic Acceleration/Deceleration Correction at Inertia (Eccentricity) Setting	233
3.4.3.2.7 Calculating the Moment of Inertia	233
3.4.4 Safety Information for Auto Acceleration of Joint #3	235
3.4.4.1 Automatic Acceleration/Deceleration Correction by Shaft Position	235
3.5 Work Envelope	237
3.5.1 Work Envelope Setting by Pulse Range	237
3.5.1.1 Joint #1 Maximum Pulse Range	238
3.5.1.2 Joint #2 Maximum Pulse Range	238
3.5.1.3 Joint #3 Maximum Pulse Range	241
3.5.1.4 Joint #4 Maximum Pulse Range	242
3.5.2 Setting the Work Envelope by Mechanical Stops	243
3.5.2.1 Setting the Mechanical Stops of Joints #1 and #2	244
3.5.2.2 Setting the Mechanical Stop of Joint #3	250
3.5.3 Setting the Rectangular Range in the XY Coordinate System of the Manipulator	253
3.5.4 Standard Work Envelope	253
4. GX10 GX20 Manipulators	261
4.1 Safety	262
4.1.1 Conventions Used in This Manual	262

4.1.2 Design and Installation Safety	263
4.1.2.1 Strength of the Ball Screw Spline	263
4.1.3 Operation Safety	264
4.1.4 Emergency Stop	265
4.1.5 Safeguard (SG)	265
4.1.6 Arm Movement Method in the Emergency Stop State	266
4.1.7 ACCELS Setting for CP Motion	268
4.1.8 Warning Labels	269
4.1.8.1 Warning Labels	269
4.1.8.2 Information Labels	269
4.1.8.3 Labelled Locations	270
4.1.9 Responses for Emergencies or Malfunctions	271
4.1.9.1 When a Collision with the Manipulator Occurs	271
4.1.9.2 Entanglement with the Manipulator	271
4.2 Specifications	273
4.2.1 Model Name GX10-B/GX20-B	273
4.2.2 Model Name GX10-C/GX20-C	278
4.2.3 Names of Parts and Their Dimensions	283
4.2.3.1 Table Top Mounting Specifications	283
4.2.3.2 Wall Mounting Specifications	289
4.2.3.3 Ceiling Mounting Specifications	296
4.2.4 Specifications Table	303
4.2.5 How to Set the Model	303
4.3 Environment and Installation	303
4.3.1 Environment	303
4.3.2 Base Table	305
4.3.3 Manipulator Mounting Dimensions	307
4.3.4 From Unpacking to Installation	309
4.3.4.1 Safety Information for the Flow from Unpacking to Installation	309
4.3.4.2 Table Top Mounting Specifications	312
4.3.4.3 Wall Mounting Specifications	314
4.3.4.4 Ceiling Mounting Specifications	315
4.3.4.5 Cleanroom & ESD-Model	317
4.3.4.6 Protected-Model	317
4.3.5 Connecting the Cables	318

4.3.6 User Wires and Pneumatic Tubes	320
4.3.6.1 Electrical Wires	321
4.3.6.2 Pneumatic Tubes	321
4.3.7 Relocation and Storage	324
4.3.7.1 Safety Information for Relocation and Storage	324
4.3.7.2 Table Top Mounting Specifications	325
4.3.7.3 Wall Mounting Specifications	328
4.3.7.4 Ceiling Mounting Specifications	331
4.4 Setting the Hand	334
4.4.1 Installing the Hand	334
4.4.2 Attaching Cameras and Valves	336
4.4.3 Weight and Inertia Settings	338
4.4.3.1 Weight Setting	338
4.4.3.1.1 Weight of Load Attached to Shaft	338
4.4.3.1.2 Weight of Load Attached to Arm	338
4.4.3.1.3 Automatic Speed Correction at Weight Setting	340
4.4.3.1.4 Automatic Acceleration/Deceleration Correction at Weight Setting	340
4.4.3.2 Inertia Setting	341
4.4.3.2.1 Moment of Inertia and Inertia Setting	341
4.4.3.2.2 Moment of Inertia of Load Attached to Shaft	341
4.4.3.2.3 Automatic Acceleration/Deceleration Correction of Joint #4 at Inertia (Moment of Inertia) Setting	342
4.4.3.2.4 Eccentricity and Inertia Setting	342
4.4.3.2.5 Eccentricity of Load Attached to Shaft	343
4.4.3.2.6 Automatic Acceleration/Deceleration Correction at Inertia (Eccentricity) Setting	343
4.4.3.2.7 Calculating the Moment of Inertia	343
4.4.4 Safety Information for Auto Acceleration of Joint #3	345
4.4.4.1 Automatic Acceleration/Deceleration Correction by Shaft Position	345
4.5 Work Envelope	346
4.5.1 Work Envelope Setting by Pulse Range	346
4.5.1.1 Joint #1 Maximum Pulse Range	347
4.5.1.2 Joint #2 Maximum Pulse Range	347
4.5.1.3 Joint #3 Maximum Pulse Range	349
4.5.1.4 Joint #4 Maximum Pulse Range	350

4.5.2 Setting the Work Envelope by Mechanical Stops	351
4.5.2.1 Setting the Mechanical Stops of Joints #1 and #2	352
4.5.2.2 Setting the Mechanical Stop of Joint #3	356
4.5.3 Setting the Rectangular Range in the XY Coordinate System of the Manipulator	362
4.5.4 Standard Work Envelope	362
5. Periodic Inspection	369
5.1 GX4 Manipulator Periodic Inspection	370
5.1.1 Inspection	370
5.1.1.1 Inspection Schedule	370
5.1.1.2 Inspection Details	372
5.1.2 Overhaul (Parts Replacement)	373
5.1.3 Applying Grease	374
5.1.4 Tightening the Hexagon Socket Head Cap Bolts	378
5.2 GX8 Manipulator Periodic Inspection	379
5.2.1 Inspection	379
5.2.1.1 Inspection Schedule	379
5.2.1.2 Inspection Details	381
5.2.2 Overhaul (Parts Replacement)	382
5.2.3 Applying Grease	382
5.2.4 Tightening the Hexagon Socket Head Cap Bolts	387
5.3 GX10/GX20 Manipulator Periodic Inspection	388
5.3.1 Inspection	388
5.3.1.1 Inspection Schedule	388
5.3.1.2 Inspection Details	390
5.3.2 Overhaul (Parts Replacement)	391
5.3.3 Applying Grease	391
5.3.4 Tightening the Hexagon Socket Head Cap Bolts	396
6. Appendix	397
6.1 Appendix A: Specifications Table	398
6.1.1 GX4	398
6.1.2 GX8	404
6.1.3 GX10/20	410
6.2 Appendix B: Stopping Time and Stopping Distance at Emergency Stop	416
6.2.1 GX4 Stopping Time and Stopping Distance at Emergency Stop	417

6.2.2 GX8 Stopping Time and Stopping Distance at Emergency Stop	423
6.2.3 GX10 Stopping Time and Stopping Distance at Emergency Stop	429
6.2.4 GX20 Stopping Time and Stopping Distance at Emergency Stop	431
6.3 Appendix C: Stopping Time and Stopping Distance When Safeguard is Open	433
6.3.1 GX4 Stopping Time and Stopping Distance When Safeguard is Open	434
6.3.2 GX8 Stopping Time and Stopping Distance When Safeguard is Open	440
6.3.3 GX10 Stopping Time and Stopping Distance When Safeguard is Open	446
6.3.4 GX20 Stopping Time and Stopping Distance When Safeguard is Open	448
6.4 Appendix D: Correction Area for Arm Length Correction	450
6.4.1 GX4 Series	450
6.4.2 GX8 Series	451
6.5 Appendix E: Included Items	452
6.5.1 GX4 series	452
6.5.2 GX8 series	452
6.5.3 GX10/20 series	453

1. Introduction

1.1 Introduction

Thank you for purchasing this Epson robot system. This manual provides the information necessary for correctly using the robot system.

Before using the system, please read this manual and related manuals to ensure correct use.

After reading this manual, store it in an easily accessible location for future reference.

Epson conducts rigorous testing and inspection to ensure that the performance of our robot systems meets our standards. Please note that if the Epson robot system is used outside the operating conditions described in the manual, the product will not perform up to its basic performance.

This manual describes potential hazards and problems that are foreseen. To use the Epson robot system safely and correctly, be sure to follow the safety information contained in this manual.

1.2 Trademarks

Microsoft, Windows, and the Windows logo are either registered trademarks or trademarks of Microsoft Corporation in the United States and/or other countries. All other company names, brand names, and product names are registered trademarks or trademarks of their respective companies.

1.3 Terms of Use

No part of this instruction manual may be reproduced or reprinted in any form without express written permission.

The information in this document is subject to change without notice.

Please contact us if you find any errors in this document or if you have any questions about the information in this document.

1.4 Manufacturer

SEIKO EPSON CORPORATION

1.5 Contact Information

Contact information details are listed in the "Supplier" section in the following manual.

Note that the contact information may vary depending on your region.

"Safety Manual - Contact Information"

The Safety Manual is also available at the following site.

URL: <https://download.epson.biz/robots/>



1.6 Disposal

When disposing of this product, please do so in accordance with the laws and regulations of your country.

1.7 Before Use

Before using this manual, be sure that you understand the following information.

Control system configuration

The GX Manipulator is made up of a combination of the following Controller and software.

Manipulator	Controller	Software
GX-A series	RC700-D	EPSON RC+ 7.0 Ver. 7.5.1B or later Epson RC+ 8.0
GX4-B, GX8-B series	RC700-E	EPSON RC+ 7.0 Ver.7.5.4 or later Epson RC+ 8.0
GX10-B, GX20-B series		EPSON 7.0 Ver.7.5.4A or later Epson RC+ 8.0
GX4-C, GX8-C, GX10-C, GX20-C series	RC800-A	Epson RC+ 8.0

Setting from the software

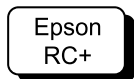

This manual contains the procedures for configuring the settings from the software.
Use of this software is indicated by the above mark.

Controller power on (off)

In this manual, an instruction to "Turn on (off) the Controller power" means to turn on the power for the hardware that makes up your Controller.

Images used in this manual

The photos and illustrations of the Manipulators shown in this manual may differ in shape and appearance from your Manipulator due to the time it was shipped, specifications, and other factors.

1.8 Manual Types for This Product

This describes the typical types of manuals for this product and presents an overview of their content.

■ Safety Manual (booklet, PDF manual)

This manual contains safety-related information intended for all people who use this product. It also guides the user through the process from unpacking to usage and the manuals that should be referred to next.

Please read this manual first.

- Safety information and residual risks of robot systems
- Declaration of Conformity
- Training
- Process from unpacking to usage

- **Robot Controller Safety Function Manual (PDF manual)**

This describes the procedures for configuring the safety functions of this product and the configuration software. It is primarily intended for those who design robot systems.

- **RC700-D Manual, RC700-E Manual, RC800-A Manual (PDF manual)**

This manual describes the installation of the entire robot system and explains the specifications and functions of the Controller. It is primarily intended for those who design robot systems.

- Robot system installation procedure (specific details on the process from unpacking to usage)
- Controller daily inspection points
- Controller specifications and basic functions

- **GX Series Manual (PDF manual)**

This manual describes the specifications and functions of the Manipulator. It is primarily intended for those who design robot systems.

- Manipulator installation, technical information needed for design, function and specification tables, etc.
- Manipulator daily inspection points

- **Status Code/Error Code List (PDF manual)**

This provides the code numbers displayed on the Controller and messages displayed in the message area of the software. It is primarily intended for those who design and program robot systems.

- **Epson RC+ User's Guide (PDF manual)**

This manual presents an overview of the program development software.

- **Epson SPEL+ Language Reference (PDF manual)**

This manual explains the robot programming language SPEL+.

Other manuals (PDF manuals)

Manuals are available for each option.

Maintenance and servicing manuals

Manuals for maintenance and servicing are not included with the product.

Maintenance should be performed by people who have received maintenance training provided by Epson and the suppliers. For more information, please contact the supplier.

2. GX4 Manipulator

This chapter contains information for setup and operation of the Manipulators. Please read this chapter thoroughly before setting up and operating the Manipulators.

2.1 Safety

The Manipulator and its related equipment should be unpacked and transported by people who have received installation training provided by Epson and the suppliers. Also, the laws and regulations of the installation country must be followed.

Before use, please read this manual and other related manuals to ensure correct use.

After reading this manual, store it in an easily accessible location for future reference.

This product is intended for transporting and assembling parts in a safely isolated area.

2.1.1 Conventions Used in This Manual

The following symbols are used in this manual to indicate important safety information. Be sure to read the descriptions shown with each symbol.

WARNING

This symbol indicates an imminently hazardous situation which, if operation is not performed properly, will result in death or serious injury.

WARNING

This symbol indicates a potentially hazardous situation which, if operation is not performed properly, could result in serious bodily injury due to electric shock.

CAUTION

This symbol indicates a potentially hazardous situation which, if operation is not performed properly, may result in an injury or in property damage only.

2.1.2 Design and Installation Safety

The robot system should be designed and installed by people who have received installation training provided by Epson and the suppliers.

Design personnel should refer to the following manuals:

"Safety Manual"

"Controller Manual"

"Manipulator Manual"

Refer to the following section for the installation safety information.

Environment and Installation

Be sure to read this section and follow the safety information before installation to ensure that the installation work is performed safely.

2.1.2.1 Strength of the Ball Screw Spline

If a load exceeding the allowable bending load is applied to the ball screw spline, it may not work properly due to deformation or breakage of the shaft.

If a load exceeding the allowable value is applied to the ball screw spline, the ball screw spline unit must be replaced.

The allowable load varies depending on the distance over which the load is applied. To calculate the allowable load, refer to the formula below.

Allowable bending moment

GX4: $M=13,000 \text{ N}\cdot\text{mm}$

Calculation example: 130 N load applied at 100 mm from the end of the spline nut

Moment

$M=F\cdot L=100\cdot 130=13,000 \text{ N}\cdot\text{mm}$

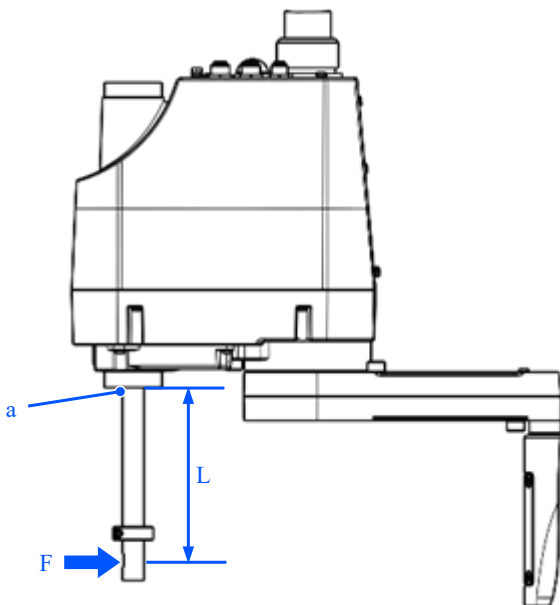

Symbol	Description
a	Spline nut end

2.1.3 Operation Safety

The following items are safety precautions for operating personnel:

WARNING

- Be sure to read the Safety Manual before use. Operating the robot system without understanding the safety information can be extremely dangerous and may result in serious injury or severe equipment damage.
- Before operating the robot system, make sure that no one is inside the safety barriers. The robot system can be operated in the teaching operation mode even when someone is inside the safety barriers. Even though the motion of the Manipulator is always restricted (low speed and low power) to ensure operator safety, an unexpected movement by the Manipulator can be extremely dangerous and may cause serious safety problems.
- If the Manipulator makes any abnormal movements during operation of the robot system, do not hesitate to immediately press the emergency stop switch.

WARNING

- To perform the power supply lockout, remove the power plug. Be sure to connect the AC power cable to a power outlet. Do not connect it directly to a factory power source.
- Before performing any replacement work, inform others in the area that you are working, and then turn off the Controller and related equipment, and unplug the power cable from the power source. Performing any work procedure with the power turned on is extremely dangerous and may result in electric shock and/or malfunction of the robot system.
- Do not connect or disconnect the connector of the M/C cable while the Controller is turned on. There is a risk the Manipulator may malfunction, which is extremely hazardous. Also, performing any work procedure with the power turned on may result in electric shock and/or malfunction of the robot system.
- Be sure to turn off the power and tag out (e.g., with a "DO NOT TURN ON" sign) before performing wiring. Performing any work procedure with the power turned on is extremely dangerous and may result in electric shock and/or malfunction of the robot system.

CAUTION

- As a general rule, the robot system should be operated by only one person. If it is necessary to operate with more than one person, ensure that all personnel communicate with each other and take all necessary safety precautions.
- Joints #1, #2, and #4:
If the Manipulator is operated repeatedly with an operating angle of 5° or less, the bearings used in the joints are likely to cause oil film shortage. Repeated operation may cause premature damage. To prevent premature damage, operate the Manipulator to move each joint to an angle of 50° or more about once per hour.
Joint #3:
If the up-and-down motion of the hand is 10 mm or less, move the hand about half or more of its maximum stroke about once per hour.
- When the robot is operating at low speed (Speed: 5 to 20%), vibration (resonance) may occur continuously during operation depending on the combination of the arm orientation and hand load. Vibration occurs due to the natural vibration frequency of the arm and can be reduced by taking the following measures:
 - Changing the robot speed

- Changing the teach points
- Changing the hand load

2.1.4 Emergency Stop

Each robot system needs equipment that will allow the operator to immediately stop the system's operation. Install an emergency stop device by using emergency stop input from the Controller or other equipment.

Before using the emergency stop switch, be aware of the following points.

- The emergency stop switch should be used to stop the Manipulator only in case of emergencies.
- Besides pressing the emergency stop switch when an emergency occurs, to stop the Manipulator during program operation, use the Pause or STOP (program stop) statements assigned to a standard I/O.
The Pause and STOP statements do not turn off motor energization, and so the brake is not locked.

To place the robot system in emergency stop mode in a non-emergency (normal) situation, press the emergency stop switch while the Manipulator is not operating.

Do not press the emergency stop switch unnecessarily while the Manipulator is operating normally. It could shorten the lifespan of the following components.

- Brakes
The brakes will be locked, which will shorten the lifespan of the brakes due to worn brake friction plates.
 - Normal brake lifespan:
About 2 years (when the brakes are used 100 times/day)
or about 20,000 times
- Reduction gears
An emergency stop applies an impact to the reduction gear, which can shorten its life.

If the Manipulator is stopped by turning off the Controller while it is operating, the following problems may occur.

- Reduced life and damage to reduction gear
- Position shift at the joints

If a power outage or other unavoidable Controller power-off occurs during Manipulator operation, check the following points after power is restored.

- Damage in reduction gear
- Shifting of the joints from their proper positions

If there was any shifting, maintenance is required. For more information, please contact the supplier.

Stopping distance of emergency stop

The Manipulator during operation cannot stop immediately after the emergency stop switch is pressed. Also, the stopping time and movement distance vary depending on the following factors.

- Hand weight, WEIGHT setting, ACCEL setting, workpiece weight, SPEED setting, movement posture, etc.

For the stopping time and movement distance of the Manipulator, refer to the following section.

[Appendix B: Stopping Time and Stopping Distance at Emergency Stop](#)

2.1.5 Safeguard (SG)

To maintain a safe working zone, safety barriers must be set up around the Manipulator, and safeguards must be installed at the entrance and exit of the safety barriers.

The term "safeguard" as used in this manual refers to a safety device with an interlock that allows entry into the safety barriers. Specifically, this includes safety door switches, safety barriers, light curtains, safety gates, safety floor mats, and so on. The safeguard is an input that informs the Robot Controller that an operator may be inside the safeguard area. You must assign at least one Safeguard (SG) in Safety Function Manager.

When the safeguard is opened, Protective Stop operates to change to the safeguard open state (display: SO).

- Safeguard open
Operations are prohibited. Further robot operation is not possible until either the safeguard is closed, the latched state is released, and a command is executed, or the TEACH or TEST operation mode is turned on and the enable circuit is activated.
- Safeguard closed
The robot can operate automatically in an unrestricted (high power) state.

WARNING

- If a third party accidentally releases the safeguard while an operator is working inside the safety barriers, this may result in a hazardous situation. To protect the operator working inside the safety barriers, implement measures to lock out or tag out the latch release switch.
- To protect operators working near the robot, be sure to connect a safeguard switch and make sure that it works properly.

Installing safety barriers

When installing safety barriers within the maximum range of the Manipulator, combine safety functions such as SLP. Carefully take into account the size of the hand and the workpieces to be held so that no interference occurs between the operating parts and the safety barriers.

Installing safeguards

Design the safeguards so that they satisfy the following requirements:

- When using a key switch type safety device, use a switch that forcibly opens the interlock contacts. Do not use switches that open their contacts using the spring force of the interlock.
- When using an interlock mechanism, do not disable the interlock mechanism.

Considering the stopping distance

During operation, the Manipulator cannot stop immediately even if the safeguard is opened. Also, the stopping time and movement distance vary depending on the following factors.

Hand weight, WEIGHT setting, ACCEL setting, workpiece weight, SPEED setting, movement posture, etc.

For the stopping time and movement distance of the Manipulator, refer to the following section.

[Appendix C: Stopping Time and Stopping Distance When Safeguard is Open](#)

Precautions for safeguard operation

Do not open the safeguard unnecessarily while the motor is energized. Frequent safeguard inputs will reduce the life of the relay.

- Normal relay lifespan: About 20,000 times

2.1.6 Arm Movement Method in the Emergency Stop State

In the emergency stop state, move the Manipulator joints directly by hand as shown below.

- **Joint #1:**
Push Arm #1 by hand.

- **Joint #2:**
Push Arm #2 by hand.

- **Joint #3:**
The joint cannot be moved up or down by hand because the electromagnetic brake is activated.
Move the joint while pressing down the brake release switch.

- **Joint #4:**
The joint cannot be rotated by hand because the electromagnetic brake is activated.
Move the joint while pressing down the brake release switch.

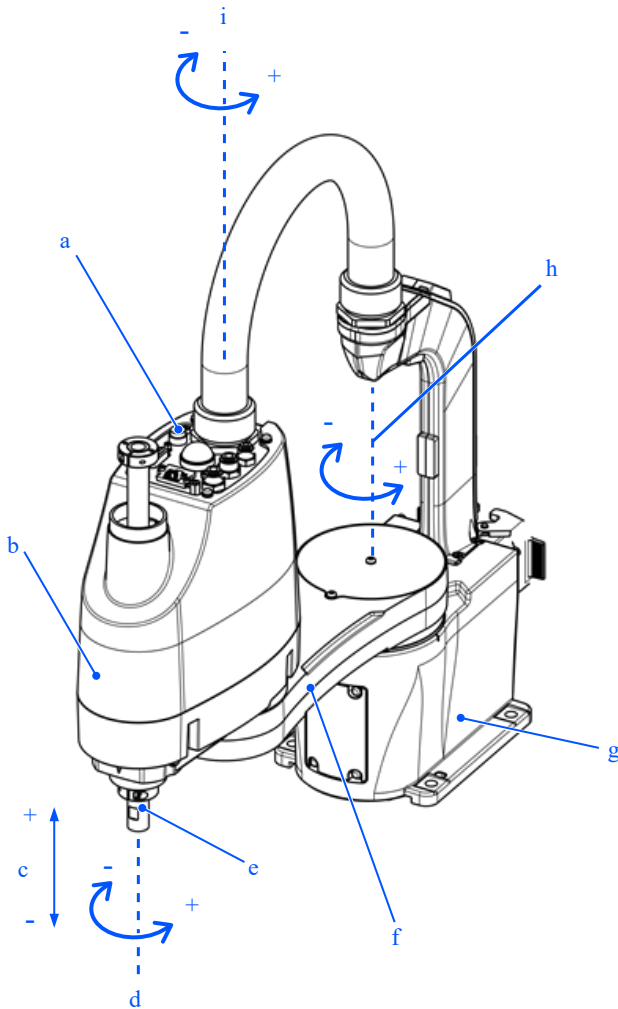

Symbol	Description
a	Joint #3 and Joint #4 brake release switch
b	Arm #2
c	Joint #3 (up/down movement)
d	Joint #4 (rotation)

Symbol	Description
e	Shaft
f	Arm #1
g	Base
h	Joint #1 (rotation)
i	Joint #2 (rotation)

KEY POINTS

The brake release switch is used with both Joint #3 and Joint #4. Press the brake release switch while in the emergency stop state to simultaneously release the brakes on Joint #3 and Joint #4.

When pressing the brake release switch, watch for the shaft descending or rotating under the weight of the hand.

2.1.7 ACCELS Setting for CP Motion

To make the Manipulator move in a CP motion, make the appropriate ACCELS settings in the SPEL program based on the tip load and Z-axis height.

KEY POINTS

If the ACCELS settings are not properly configured, the following problem may occur.

- Shortened lifespan and damage to the ball screw spline

Set ACCELS as shown below based on the Z-axis height.

ACCELS setting values by the Z-axis height and tip load

Z-axis Height (mm)	Tip Load	
	3 kg or Less	4 kg or Less
- 0 > Z ≥ - 50	25000 or less	25000 or less
- 50 > Z ≥ - 100		25000 or less
- 100 > Z ≥ - 150		21500 or less

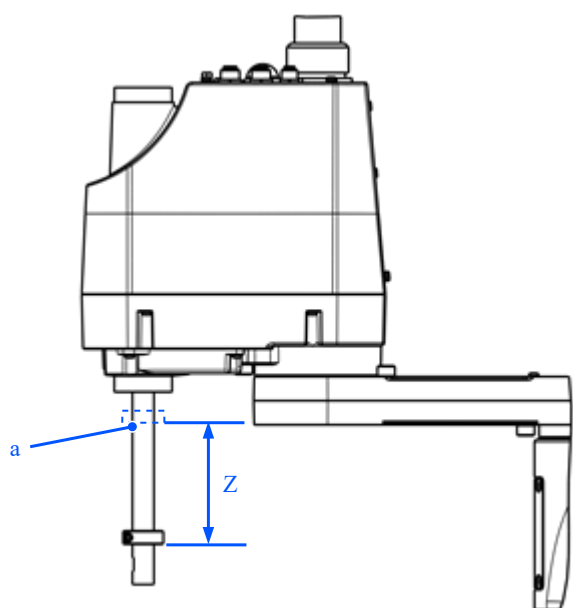

Symbol	Description
a	Z-axis height 0 (origin position)

Also, if a CP motion was performed with incorrect values set, check the following point.

- No deformation or bending of the shaft of the ball screw spline

2.1.8 Warning Labels

The Manipulator has the following warning labels.

Specific hazards exist in the vicinity of areas with the warning labels. Be thoroughly careful in handling.

To ensure that the Manipulator is operated and maintained safely, be sure to follow the safety information and warnings indicated on the warning labels. Also, do not tear, damage, or remove these warning labels.

2.1.8.1 Warning Labels

A



Touching any internal electrified parts while the power is turned on may cause electric shock.

Also, regarding the cleanroom & ESD specifications and the ESD specifications, if the cables inside the Manipulator wear down over a long period of operation and cause an internal short circuit, the conduit tube may be electrified. Touching the conduit tube while the power is turned on may cause electric shock.

B

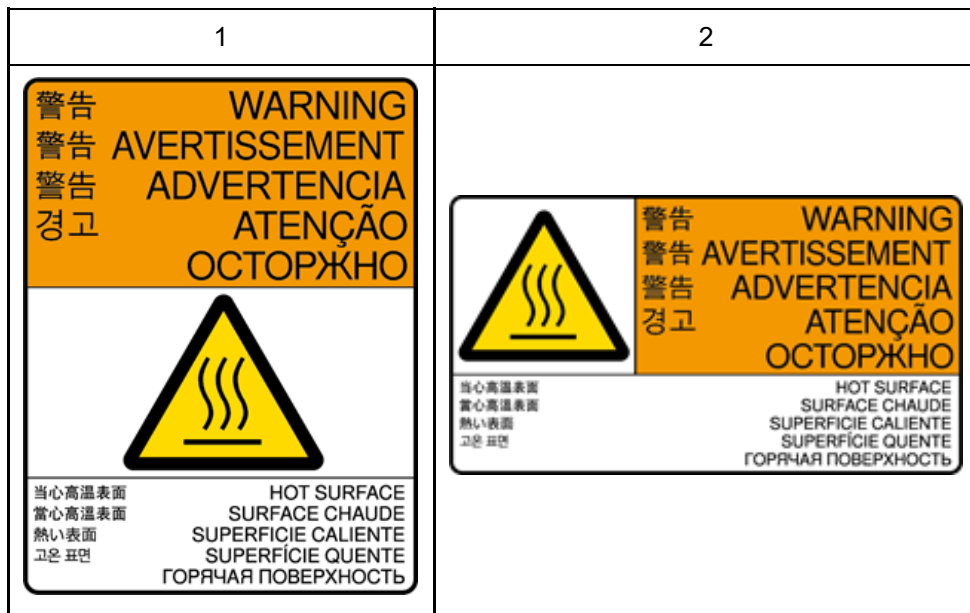

The surface of the Manipulator is hot during and after operation, and there is a risk of burns.

2.1.8.2 Information Labels

1

This indicates the product name, model name, serial number, information of supported laws and regulations, product specifications (Weight, MAX.REACH, MAX.PAYLOAD, AIR PRESSURE, Motor Power), Main document No.,

manufacturer, importer, date of manufacture, country of manufacture, and the like.
For details, see the label affixed to the product.

2

BRAKE RELEASE

Indicates the position of a brake release button.

2.1.8.3 Labelled Locations

Common (Arm #2)

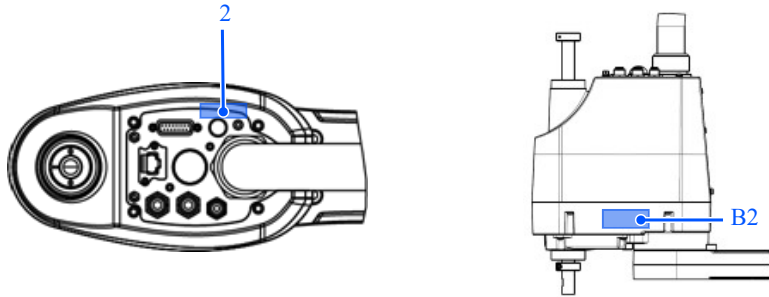

Table top mounting specifications

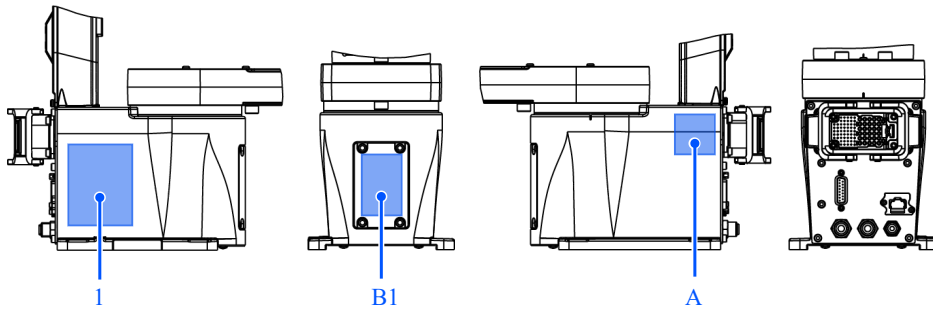
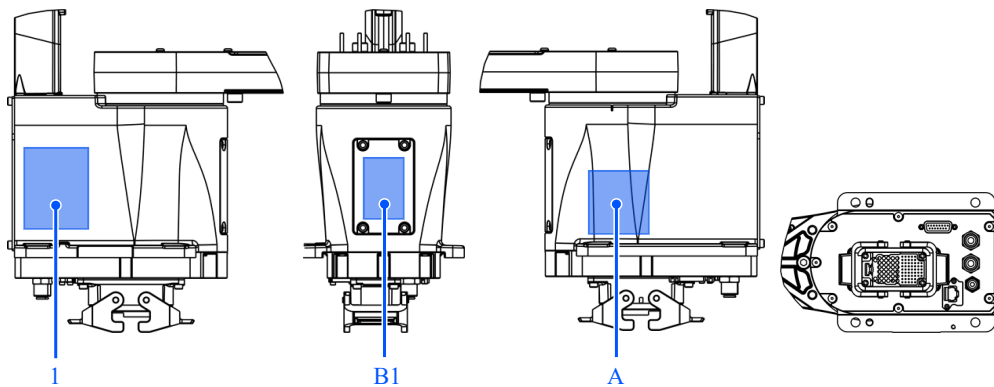
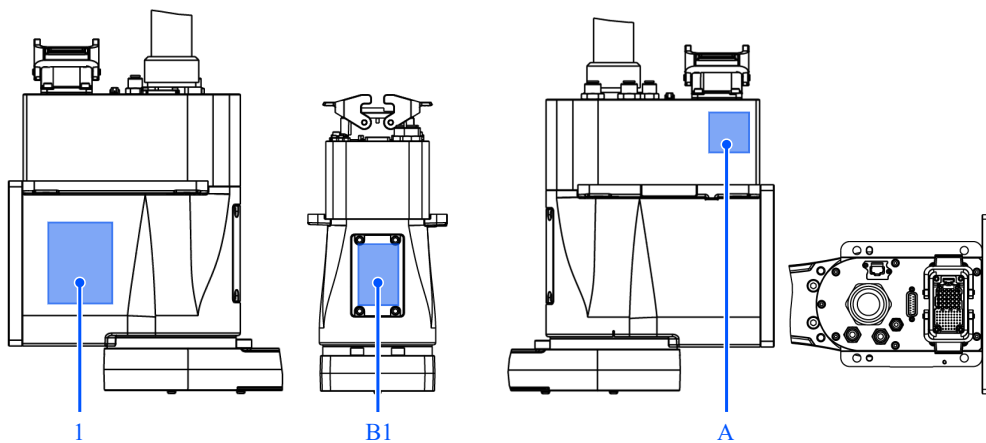

Table top mounting specifications (cable routing from bottom side)



Multiple mounting specifications



2.1.9 Responses for Emergencies or Malfunctions

2.1.9.1 When a Collision with the Manipulator Occurs

If the Manipulator has collided with a mechanical stop, peripheral device, or other object, discontinue use and contact the supplier.

2.1.9.2 Entanglement with the Manipulator

If an operator gets caught between the Manipulator and a mechanical part such as a base table, press the emergency stop switch to release the operator by using the following method.

- Operator body is entangled with a robot arm
The brake is not functioning. Move the arm manually.
- Operator body is entangled with the shaft
The brake is functioning. Press the brake release switch, and move the shaft.

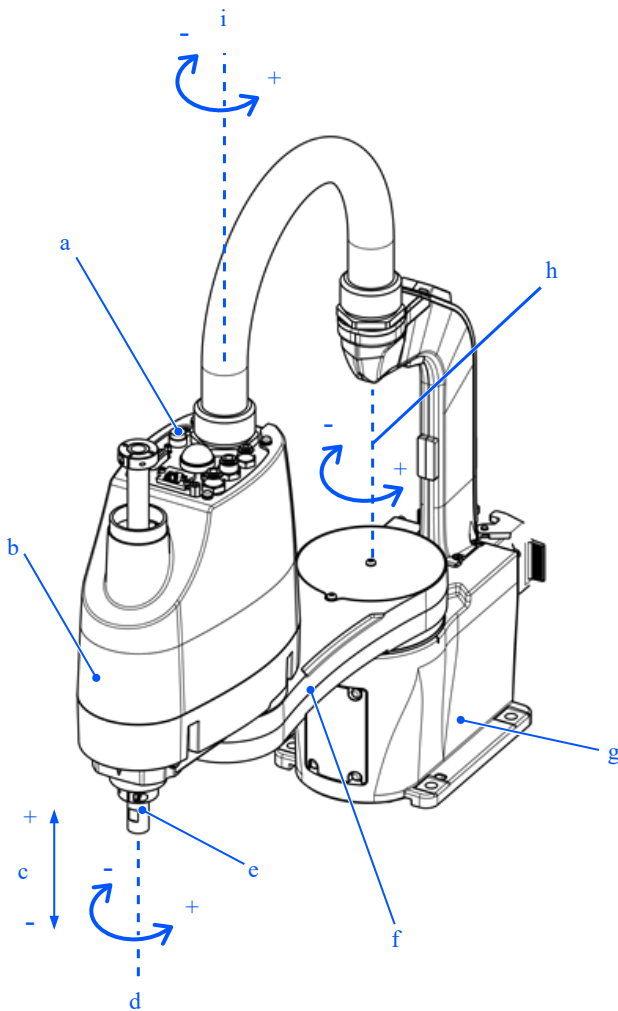

Symbol	Description
a	Joint #3 and Joint #4 brake release switch
b	Arm #2
c	Joint #3 (up/down movement)

Symbol	Description
d	Joint #4 (rotation)
e	Shaft
f	Arm #1
g	Base
h	Joint #1 (rotation)
i	Joint #2 (rotation)

 CAUTION

- While the brake release switch is being pressed, in addition to Joint #3, Joint #4 may also move due to its own weight. Be careful of the shaft descending and rotating.

2.2 Specifications

2.2.1 Model Name GX4-A

GX4-A25 1 S □ □ □ □
 [a] [b] [c] [d] [e] [f] [g]

- **a: Arm length**
 25: 250 mm
 30: 300 mm
 35: 350 mm
- **b: Joint #3 stroke**
 1: 150 mm (GX4-A**1S*, E*), 120 mm (GX4-A**1C*)
- **c: Environmental specifications**
 S: Standard (equivalent to IP20)
 E: ESD (anti-static)
 C: Cleanroom & ESD (anti-static)
- **d: Mounting specifications**
 □: Table top mounting
 M: Multiple mounting
- **e: Cable mounting direction**
 □: Standard (table top mounting - cable routing from rear side, multiple mounting - cable routing from top side)
 B: Cable routing from bottom side (table top mounting only)
- **f: Arm type**
 □: Straight
 -L: Left-curved
 -R: Right-curved
- **g: Standard**
 □: Standard
 -UL: UL1740 certified

Environmental specifications

- ESD (anti-static) specifications: GX4-A**1E*
 ESD specifications are specifications that use conductive materials for or apply plating to the major resin parts as anti-static measures.
 We have confirmed that the Manipulator tip (tool mounting section) is at ± 5 V or less, even directly after the measuring operation according to Seiko Epson standards.
 If you need any other detailed information, please contact the supplier.
 Also, please check the amount of charge on any hand, wiring, or the like that you will attach to the robot on your own before use.
- Cleanroom & ESD (anti-static) specifications: GX4-A**1C*
 Manipulators with cleanroom & ESD (anti-static) specifications have a base design with the standard specifications, but as an additional feature, have reduced dust emissions from the Manipulator to enable use in cleanroom environments.

For details on the specifications, refer to the following section.

[Appendix A: Specifications Table](#)

Model list

Arm Length	Joint #3 Stroke	Environmental Specifications	Mounting Specifications	Cable Mounting Direction	Arm Type	Model Number
250	150	Standard	Table top	Standard	Straight	GX4-A251S
				Cable routing from bottom side		GX4-A251SB
		ESD		Standard		GX4-A251E
				Cable routing from bottom side		GX4-A251EB
		Cleanroom & ESD		Standard		GX4-A251C
				Cable routing from bottom side		GX4-A251CB
300	150	Standard	Table top	Standard	Straight	GX4-A301S
				Cable routing from bottom side		GX4-A301SB
		ESD	Multiple	Standard		GX4-A301SM
			Table top	Standard		GX4-A301E
				Cable routing from bottom side		GX4-A301EB
			Multiple	Standard		GX4-A301EM
300	120	Cleanroom & ESD	Table top	Standard	Straight	GX4-A301C
				Cable routing from bottom side		GX4-A301CB
			Multiple	Standard		GX4-A301CM
350	150	Standard	Table top	Standard	Straight	GX4-A351S
					Left-curved	GX4-A351S-L
					Right-curved	GX4-A351S-R
				Cable routing from bottom side	Straight	GX4-A351SB
					Left-curved	GX4-A351SB-L

Arm Length	Joint #3 Stroke	Environmental Specifications	Mounting Specifications	Cable Mounting Direction	Arm Type	Model Number
					Right-curved	GX4-A351SB-R
					Multiple	Standard
350	150	ESD	Table top	Standard	Straight	GX4-A351E
					Left-curved	GX4-A351E-L
					Right-curved	GX4-A351E-R
				Cable routing from bottom side	Straight	GX4-A351EB
					Left-curved	GX4-A351EB-L
					Right-curved	GX4-A351EB-R
			Multiple	Standard	Straight	GX4-A351EM
			350	120	Cleanroom & ESD	Table top
Left-curved	GX4-A351C-L					
Right-curved	GX4-A351C-R					
Cable routing from bottom side	Straight	GX4-A351CB				
	Left-curved	GX4-A351CB-L				
	Right-curved	GX4-A351CB-R				
Multiple	Standard	Straight				GX4-A351CM

(Units: mm)

2.2.2 Model Name GX4-B

GX4-B25 1 S □ □ □
 [a] [b] [c] [d] [e] [f]

- **a: Arm length**
 25: 250 mm
 30: 300 mm
 35: 350 mm
- **b: Joint #3 stroke**
 1: 150 mm (GX4-B**1S*, E*), 120 mm (GX4-B**1C*)
- **c: Environmental specifications**
 S: Standard (equivalent to IP20)
 E: ESD (anti-static)
 C: Cleanroom & ESD (anti-static)
- **d: Mounting specifications**
 □: Table top mounting
 M: Multiple mounting
- **e: Cable mounting direction**
 □: Standard (table top mounting - cable routing from rear side, multiple mounting - cable routing from top side)
 B: Cable routing from bottom side (table top mounting only)
- **f: Arm type**
 □: Straight
 -L: Left-curved
 -R: Right-curved

Environmental specifications

- ESD (anti-static) specifications: GX4-B**1E*
 ESD specifications are specifications that use conductive materials for or apply plating to the major resin parts as anti-static measures.
 We have confirmed that the Manipulator tip (tool mounting section) is at ± 5 V or less, even directly after the measuring operation according to Seiko Epson standards.
 If you need any other detailed information, please contact the supplier.
 Also, please check the amount of charge on any hand, wiring, or the like that you will attach to the robot on your own before use.
- Cleanroom & ESD (anti-static) specifications: GX4-B**1C*
 Manipulators with cleanroom & ESD (anti-static) specifications have a base design with the standard specifications, but as an additional feature, have reduced dust emissions from the Manipulator to enable use in cleanroom environments.

For details on the specifications, refer to the following section.

[Appendix A: Specifications Table](#)

Model list

Arm Length	Joint #3 Stroke	Environmental Specifications	Mounting Specifications	Cable Mounting Direction	Arm Type	Model Number
250	150	Standard	Table top	Standard	Straight	GX4-B251S
				Cable routing from bottom side		GX4-B251SB
		ESD		Standard		GX4-B251E
				Cable routing from bottom side		GX4-B251EB
		Cleanroom & ESD		Standard		GX4-B251C
				Cable routing from bottom side		GX4-B251CB
300	150	Standard	Table top	Standard	Straight	GX4-B301S
				Cable routing from bottom side		GX4-B301SB
		ESD	Multiple	Standard		GX4-B301SM
			Table top	Standard		GX4-B301E
				Cable routing from bottom side		GX4-B301EB
			Multiple	Standard		GX4-B301EM
300	120	Cleanroom & ESD	Table top	Standard	Straight	GX4-B301C
				Cable routing from bottom side		GX4-B301CB
			Multiple	Standard		GX4-B301CM
350	150	Standard	Table top	Standard	Straight	GX4-B351S
					Left-curved	GX4-B351S-L
					Right-curved	GX4-B351S-R
				Cable routing from bottom side	Straight	GX4-B351SB
					Left-curved	GX4-B351SB-L

Arm Length	Joint #3 Stroke	Environmental Specifications	Mounting Specifications	Cable Mounting Direction	Arm Type	Model Number			
					Right-curved	GX4-B351SB-R			
			Multiple	Standard	Straight	GX4-B351SM			
350	150	ESD	Table top	Standard	Straight	GX4-B351E			
					Left-curved	GX4-B351E-L			
					Right-curved	GX4-B351E-R			
				Cable routing from bottom side	Straight	GX4-B351EB			
					Left-curved	GX4-B351EB-L			
					Right-curved	GX4-B351EB-R			
			Multiple	Standard	Straight	GX4-B351EM			
			350	120	Cleanroom & ESD	Table top	Standard	Straight	GX4-B351C
								Left-curved	GX4-B351C-L
Right-curved	GX4-B351C-R								
Cable routing from bottom side	Straight	GX4-B351CB							
	Left-curved	GX4-B351CB-L							
	Right-curved	GX4-B351CB-R							
Multiple	Standard	Straight				GX4-B351CM			

(Units: mm)

2.2.3 Model Name GX4-C

GX4-C25 1 S □ □ □

 [a] [b] [c] [d] [e] [f]

- **a: Arm length**
 25: 250 mm
 30: 300 mm
 35: 350 mm
- **b: Joint #3 stroke**
 1: 150 mm (GX4-C**1S*, E*), 120 mm (GX4-C**1C*)
- **c: Environmental specifications**
 S: Standard (equivalent to IP20)
 E: ESD (anti-static)
 C: Cleanroom & ESD (anti-static)
- **d: Mounting specifications**
 □: Table top mounting
 M: Multiple mounting
- **e: Cable mounting direction**
 □: Standard (table top mounting - cable routing from rear side, multiple mounting - cable routing from top side)
 B: Cable routing from bottom side (table top mounting only)
- **f: Arm type**
 □: Straight
 -L: Left-curved
 -R: Right-curved

Environmental specifications

- ESD (anti-static) specifications: GX4-C**1E*
 ESD specifications are specifications that use conductive materials for or apply plating to the major resin parts as anti-static measures.
 We have confirmed that the Manipulator tip (tool mounting section) is at ± 5 V or less, even directly after the measuring operation according to Seiko Epson standards.
 If you need any other detailed information, please contact the supplier.
 Also, please check the amount of charge on any hand, wiring, or the like that you will attach to the robot on your own before use.
- Cleanroom & ESD (anti-static) specifications: GX4-C**1C*
 Manipulators with cleanroom & ESD (anti-static) specifications have a base design with the standard specifications, but as an additional feature, have reduced dust emissions from the Manipulator to enable use in cleanroom environments.

For details on the specifications, refer to the following section.

[Appendix A: Specifications Table](#)

Model list

Arm Length	Joint #3 Stroke	Environmental Specifications	Mounting Specifications	Cable Mounting Direction	Arm Type	Model Number
250	150	Standard	Table top	Standard	Straight	GX4-C251S
				Cable routing from bottom side		GX4-C251SB
		ESD		Standard		GX4-C251E
				Cable routing from bottom side		GX4-C251EB
		Cleanroom & ESD		Standard		GX4-C251C
				Cable routing from bottom side		GX4-C251CB
300	150	Standard	Table top	Standard	Straight	GX4-C301S
				Cable routing from bottom side		GX4-C301SB
			Multiple	Standard		GX4-C301SM
			ESD	Table top		Standard
		Cable routing from bottom side				GX4-C301EB
		Multiple	Multiple	Standard		GX4-C301EM
				Cleanroom & ESD		Table top
		Cable routing from bottom side	GX4-C301CB			
Multiple	Multiple	Standard	GX4-C301CM			
		350	150		Standard	Table top
Left-curved	GX4-C351S-L					
Right-curved	GX4-C351S-R					
Cable routing from bottom side	Straight			GX4-C351SB		
	Left-curved			GX4-C351SB-L		

Arm Length	Joint #3 Stroke	Environmental Specifications	Mounting Specifications	Cable Mounting Direction	Arm Type	Model Number			
					Right-curved	GX4-C351SB-R			
			Multiple	Standard	Straight	GX4-C351SM			
350	150	ESD	Table top	Standard	Straight	GX4-C351E			
					Left-curved	GX4-C351E-L			
					Right-curved	GX4-C351E-R			
				Cable routing from bottom side	Straight	GX4-C351EB			
					Left-curved	GX4-C351EB-L			
					Right-curved	GX4-C351EB-R			
			Multiple	Standard	Straight	GX4-C351EM			
			350	120	Cleanroom & ESD	Table top	Standard	Straight	GX4-C351C
								Left-curved	GX4-C351C-L
Right-curved	GX4-C351C-R								
Cable routing from bottom side	Straight	GX4-C351CB							
	Left-curved	GX4-C351CB-L							
	Right-curved	GX4-C351CB-R							
Multiple	Standard	Straight				GX4-C351CM			

(Units: mm)

2.2.4 Names of Parts and Their Dimensions

2.2.4.1 Table Top Mounting Specifications

2.2.4.1.1 Cable Mounting Direction: Standard

Standard specifications GX4-A/GX4-B/GX4-C**1S

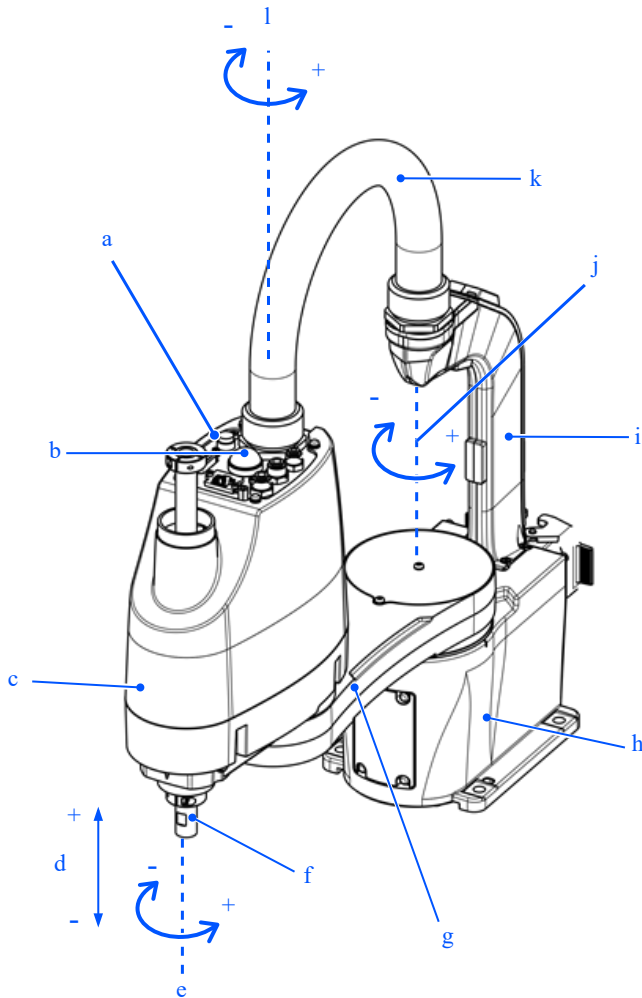

Symbol	Description
a	Joint #3 and Joint #4 brake release switch
b	Indicating lamp
c	Arm #2
d	Joint #3 (up/down movement)
e	Joint #4 (rotation)
f	Shaft
g	Arm #1
h	Base
i	Cable duct

Symbol	Description
j	Joint #1 (rotation)
k	Conduit tube
l	Joint #2 (rotation)

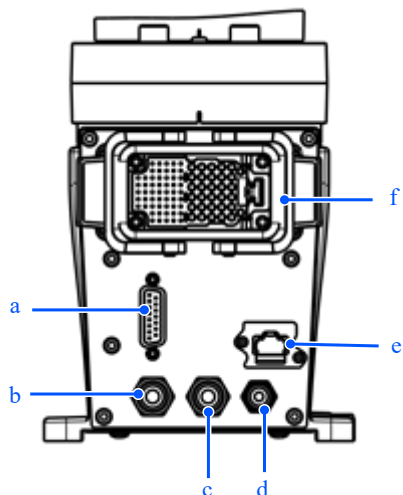

Symbol	Description
a	User connector (15-pin D-sub connector)
b	Fitting for $\varnothing 6$ mm tube (white)
c	Fitting for $\varnothing 6$ mm tube (blue)
d	Fitting for $\varnothing 4$ mm tube (blue)
e	Ethernet connector
f	M/C cable connector

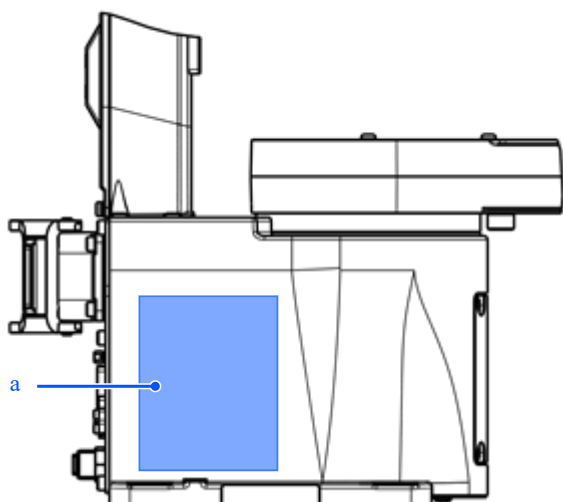

Symbol	Description
a	Face plate (serial number of Manipulator)

 **KEY POINTS**

- The brake release switch is used with both Joint #3 and Joint #4. Press the brake release switch while in the emergency stop state to simultaneously release the brakes on Joint #3 and Joint #4.

Before starting any maintenance work, be sure to turn off the Controller and inform others in the surrounding area that work is in progress. Performing any work procedure with the power turned on is extremely dangerous and may result in electric shock and/or malfunction of the robot system.

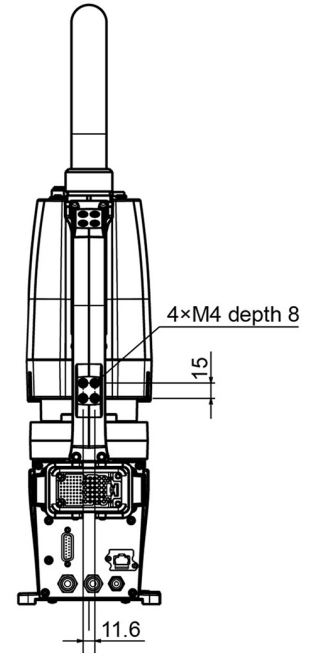
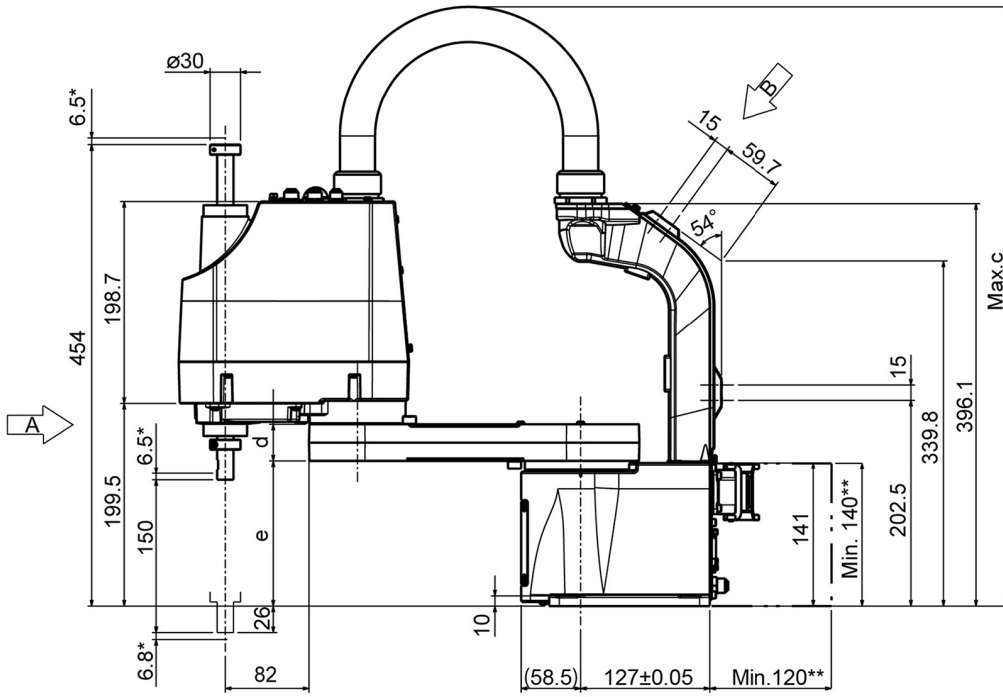
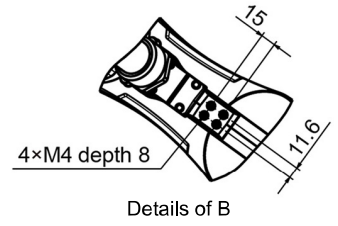
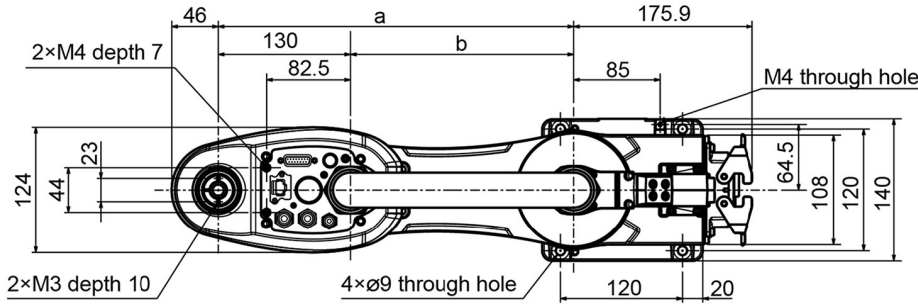

* Position of mechanical stop

** Space for connector

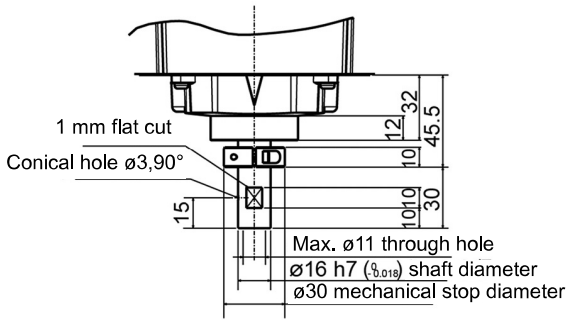
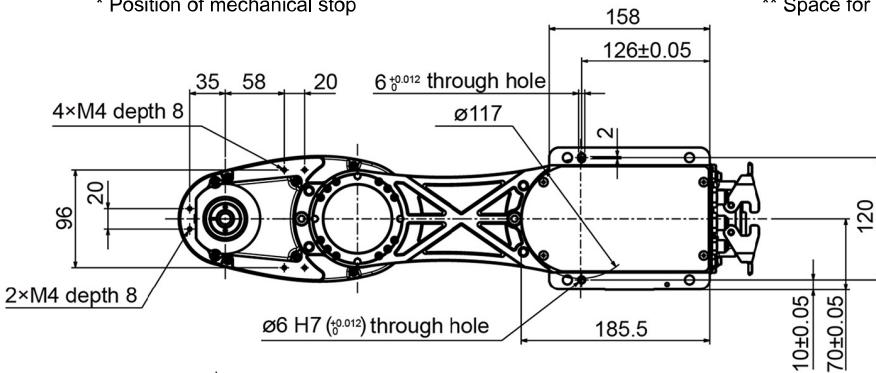

Details of A
Calibration point position of Joints #3 and #4

	GX4-A/GX4-B/ GX4-C251S, E	GX4-A/GX4-B/ GX4-C301S, E	GX4-A/GX4-B/ GX4-C351S, E
a	250	300	350
b	120	170	220
c	560	585	610
d	30	36	36
e	146	143	143

ESD specifications GX4-A/GX4-B/GX4-C1E**

The part shown below is different from the standard specifications. The external dimensions are identical.

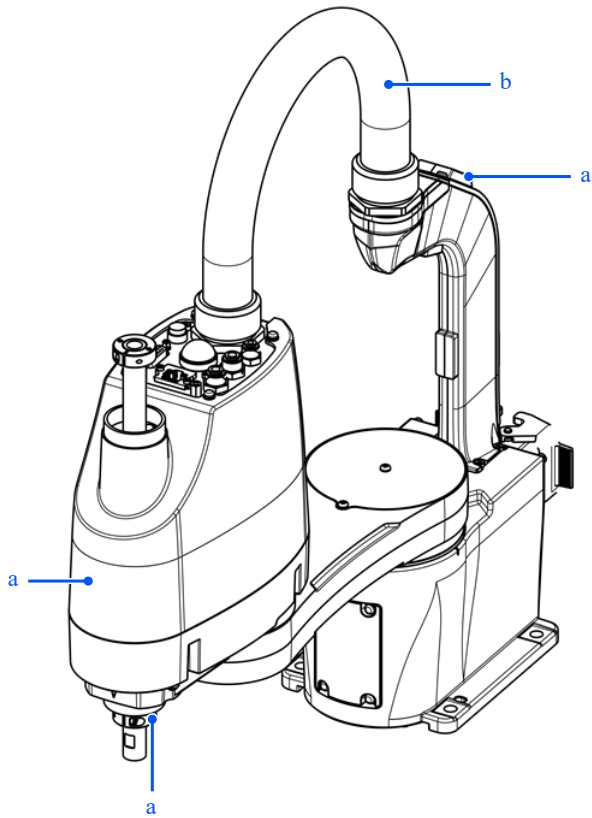

Symbol	Description
a	Plating covers (anti-static specifications)
b	Conduit Tube (anti-static specifications)

Cleanroom & ESD specifications GX4-A/GX4-B/GX4-C1C**

The parts shown below differ from the standard specifications.

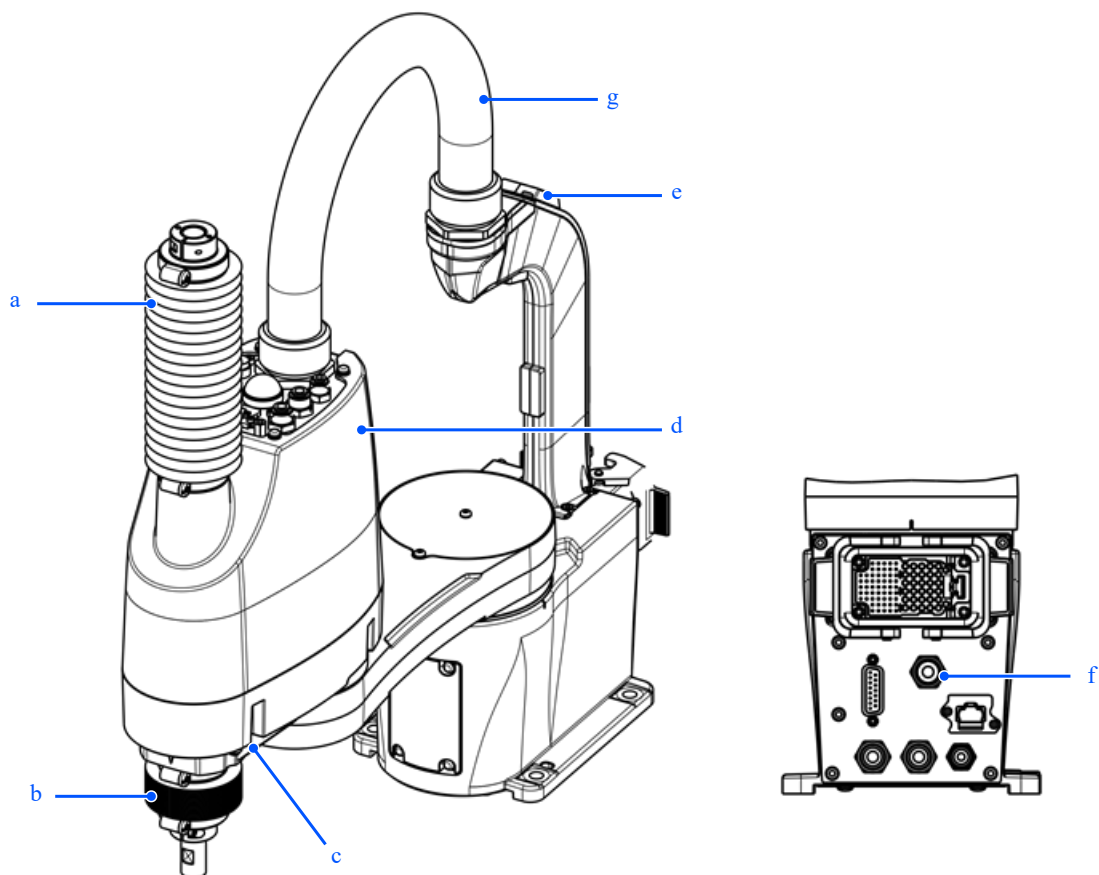

Symbol	Description
a	Upper bellows
b	Lower bellows
c	Plating cover (anti-static specifications)
d	Plating cover (anti-static specifications)
e	Plating cover (anti-static specifications)
f	Exhaust port
g	Conduit Tube (anti-static specifications)

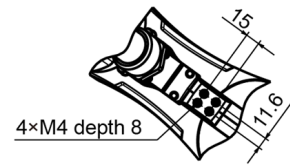
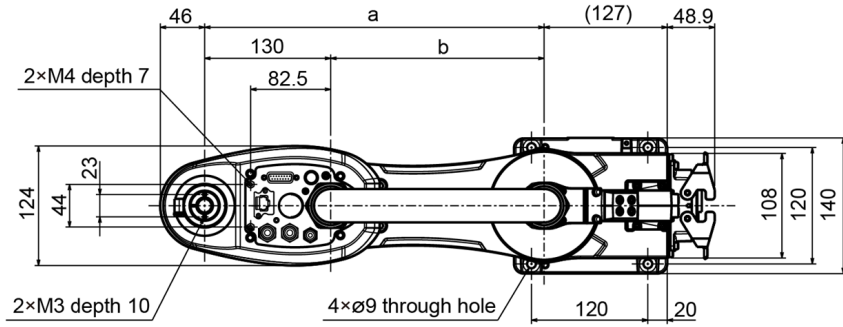

Details of B

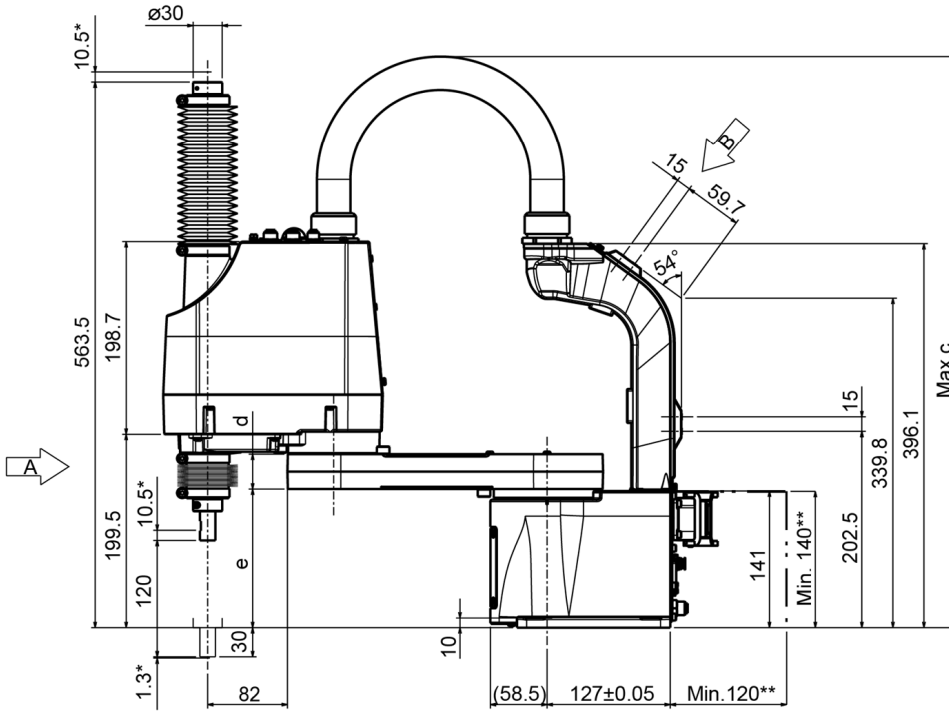

* Position of mechanical stop

** Space for connector

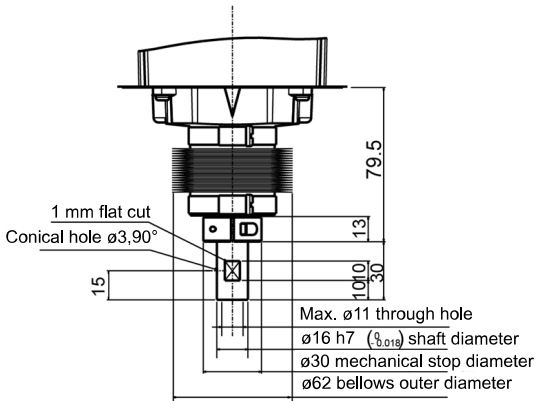
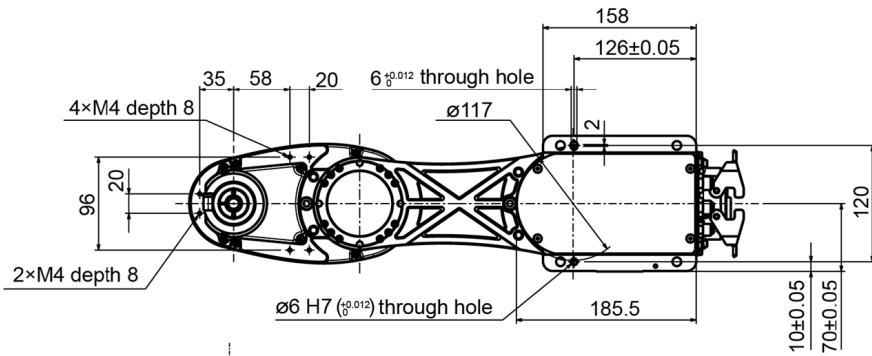
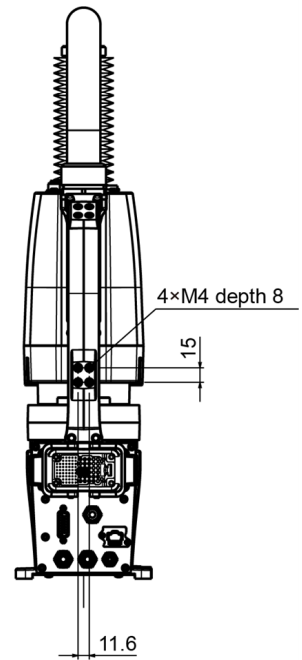

Details of A

Calibration point position of Joints #3 and #4

	GX4-A/GX4-B/ GX4-C251C	GX4-A/GX4-B/ GX4-C301C	GX4-A/GX4-B/ GX4-C351C
a	250	300	350
b	120	170	220
c	560	585	610
d	30	36	36
e	146	143	143

2.2.4.1.2 Cable Mounting Direction: Cable Routing from Bottom Side

Standard specifications GX4-A/GX4-B/GX4-C**1SB

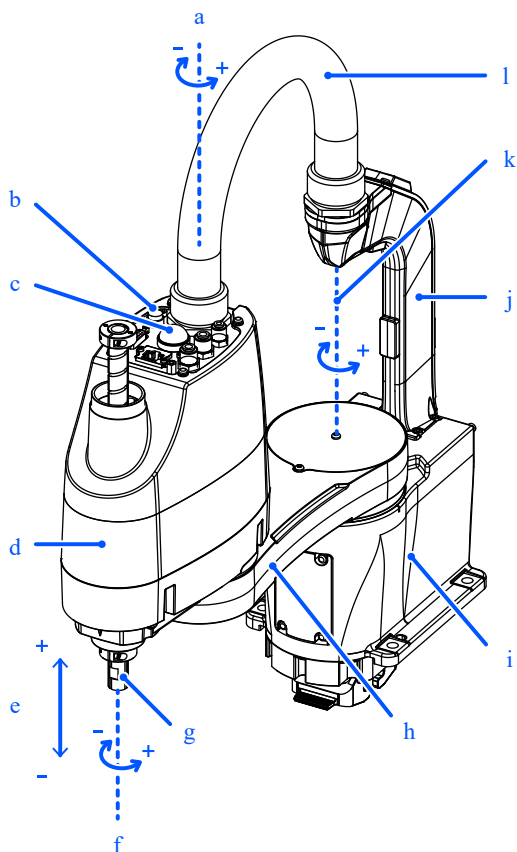

Symbol	Description
a	Joint #2 (rotation)
b	Joint #3 and Joint #4 brake release switch
c	Indicating lamp
d	Arm #2
e	Joint #3 (up/down movement)
f	Joint #4 (rotation)
g	Shaft
h	Arm #1
i	Base
j	Cable duct
k	Joint #1 (rotation)
l	Conduit tube

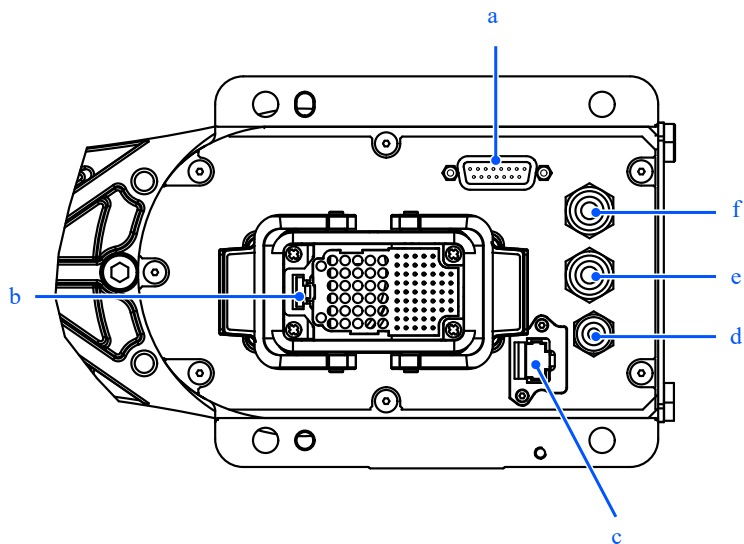

Symbol	Description
a	User connector (15-pin D-sub connector)
b	M/C cable connector
c	Ethernet connector
d	Fitting for ø4 mm tube (blue)
e	Fitting for ø6 mm tube (blue)
f	Fitting for ø6 mm tube (white)

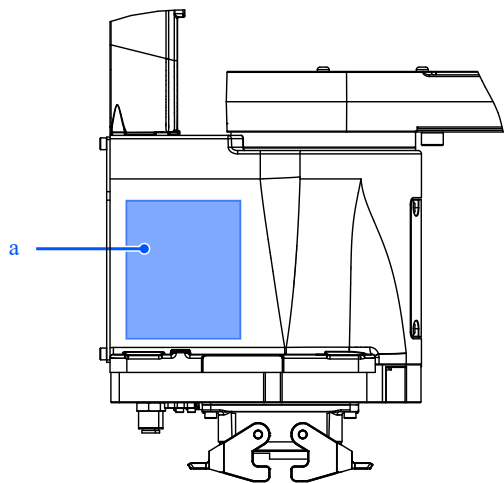

Symbol	Description
a	Face plate (serial number of Manipulator)

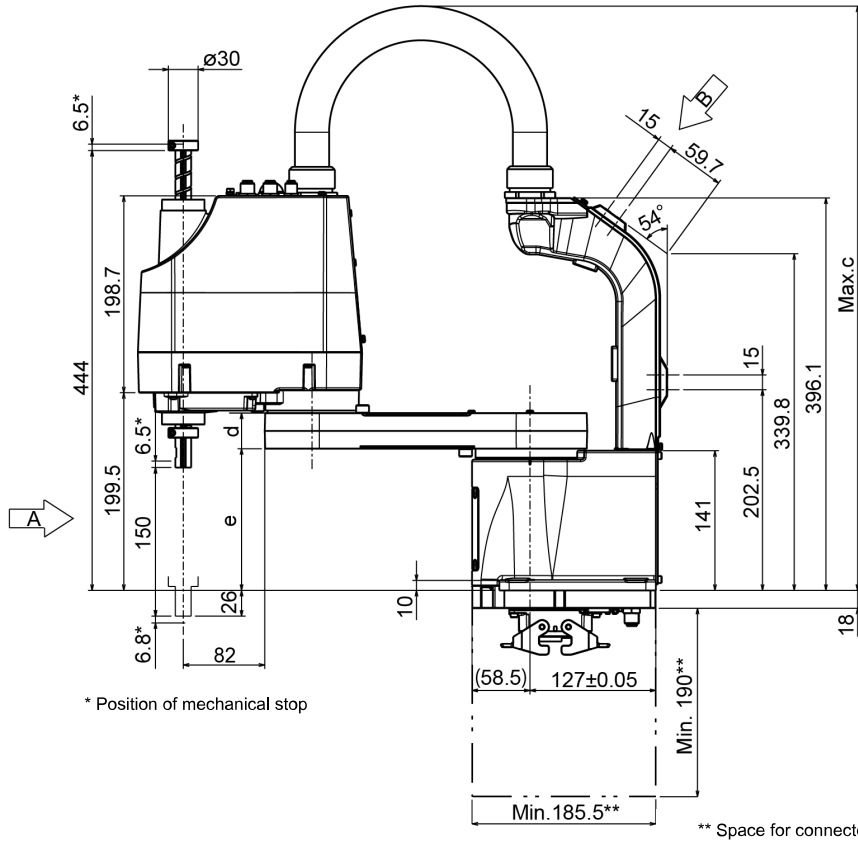
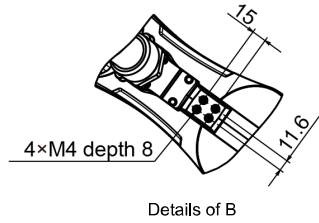
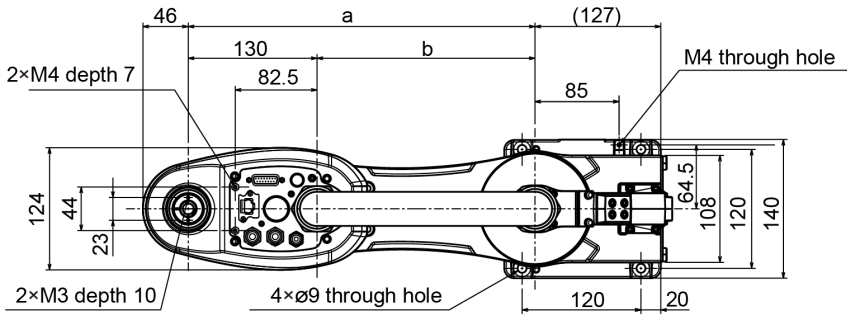

* Position of mechanical stop

** Space for connector

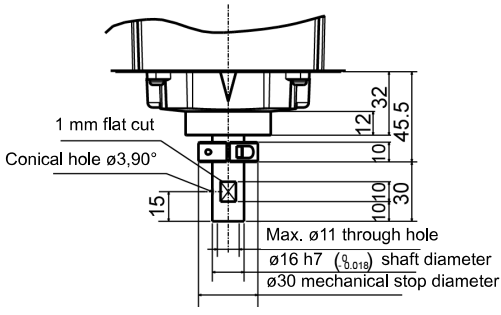
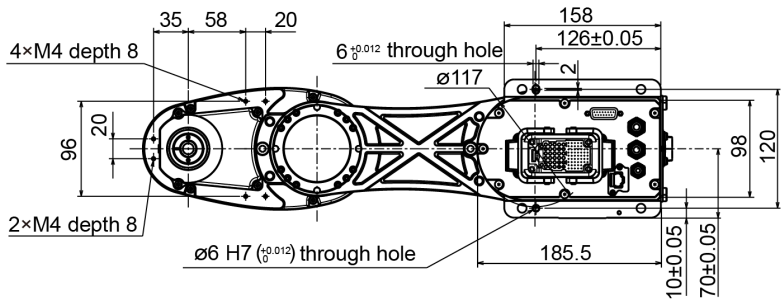
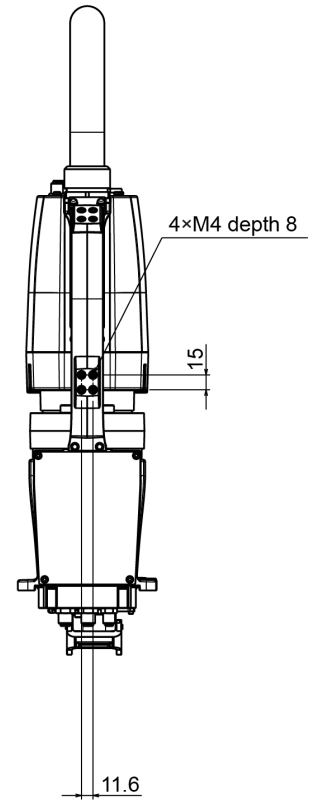

Details of A
Calibration point position of Joints #3 and #4

	GX4-A/GX4-B/ GX4-C251SB, EB	GX4-A/GX4-B/ GX4-C301SB, EB	GX4-A/GX4-B/ GX4-C351SB, EB
a	250	300	350
b	120	170	220
c	560	585	610
d	30	36	36
e	146	143	143

ESD specifications GX4-A/GX4-B/GX4-C1EB**

The part shown below is different from the standard specifications. The external dimensions are identical.

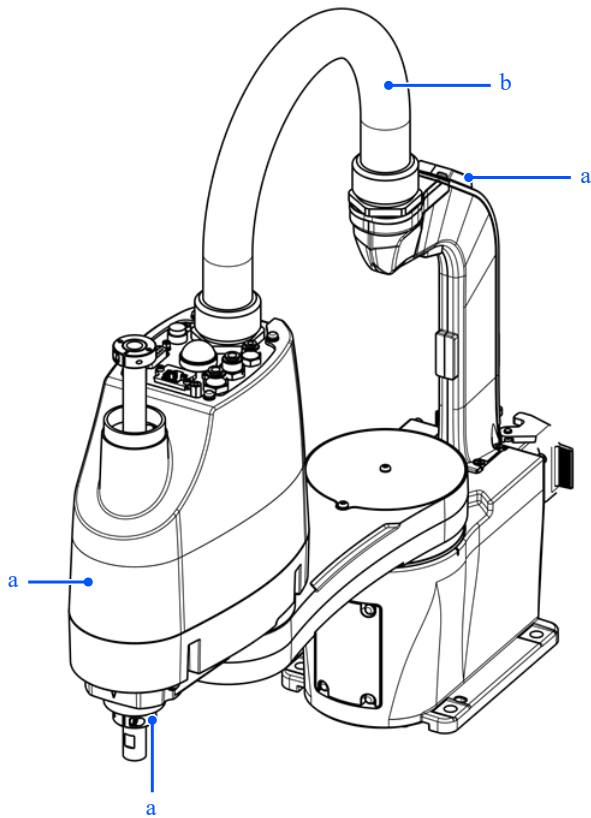

Symbol	Description
a	Plating covers (anti-static specifications)
b	Conduit Tube (anti-static specifications)

Cleanroom & ESD specifications GX4-A/GX4-B/GX4-C1CB**

The parts shown below differ from the standard specifications.

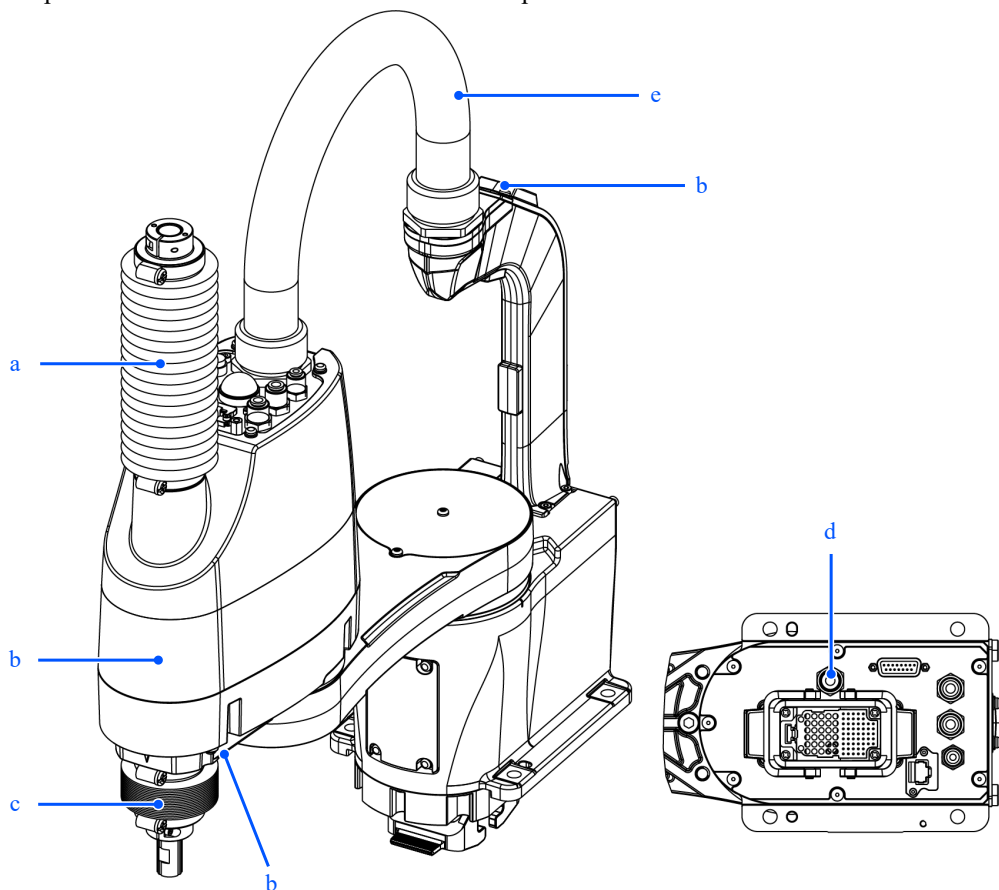

Symbol	Description
a	Upper bellows
b	Plating covers (anti-static specifications)
c	Lower bellows
d	Exhaust port
e	Conduit Tube (anti-static specifications)

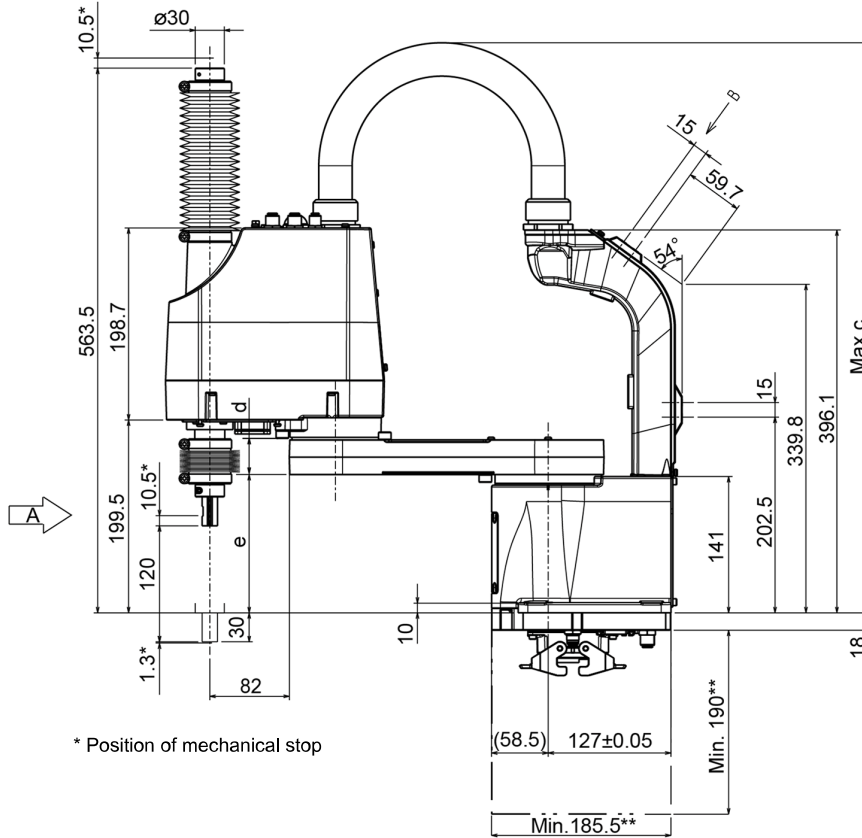
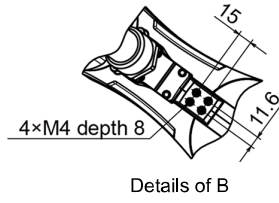
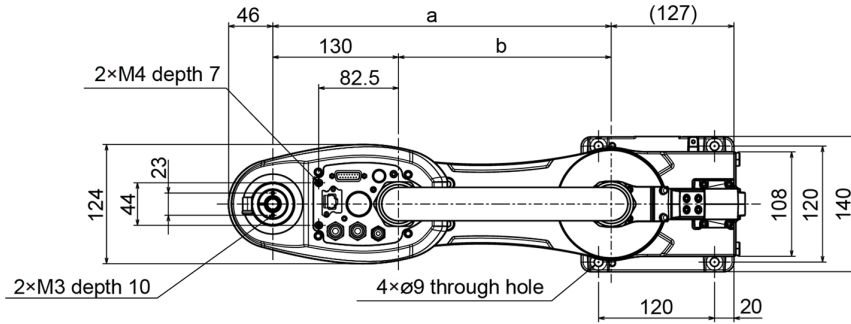

* Position of mechanical stop

** Space for connector

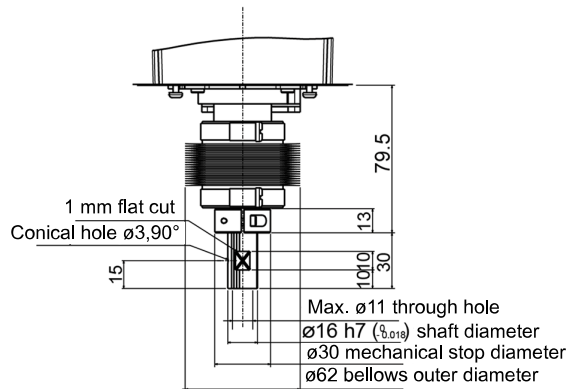
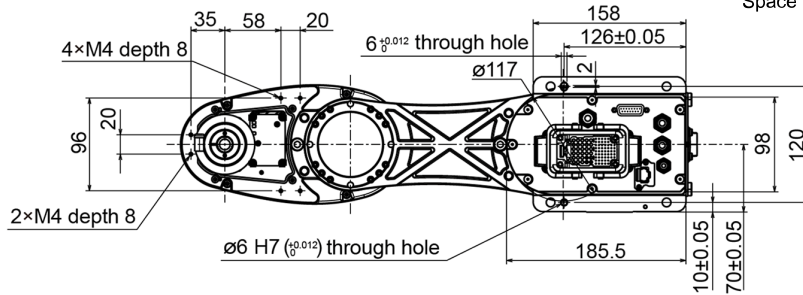

Details of A

Calibration point position of Joints #3 and #4

	GX4-A/GX4-B/ GX4-C251CB	GX4-A/GX4-B/ GX4-C301CB	GX4-A/GX4-B/ GX4-C351CB
a	250	300	350
b	120	170	220
c	560	585	610
d	30	36	36
e	146	143	143

2.2.4.2 Multiple Mounting Specifications

Standard specifications GX4-A/GX4-B/GX4-C**1SM

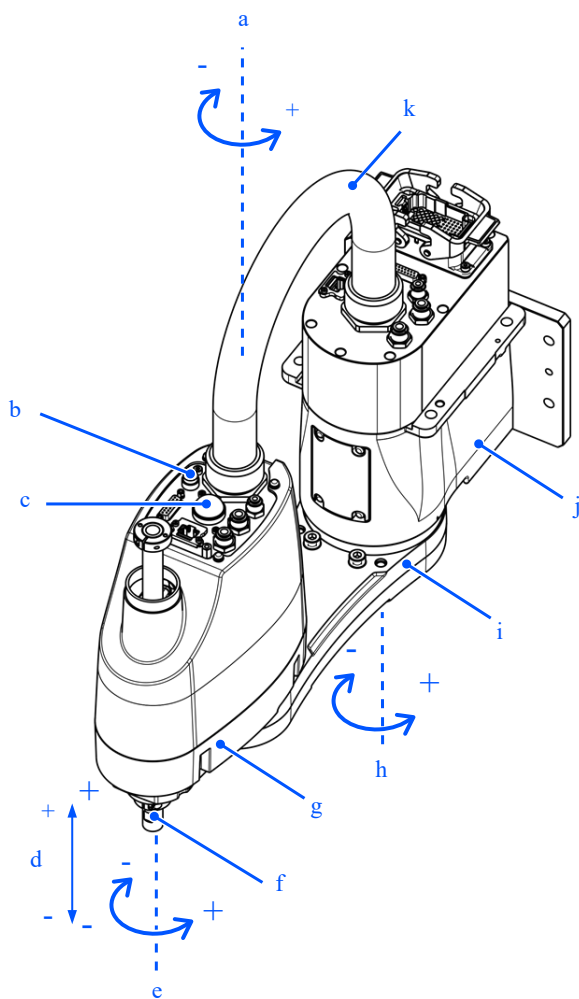

Symbol	Description
a	Joint #2 (rotation)
b	Joint #3 and Joint #4 brake release switch
c	Indicating lamp
d	Joint #3 (up/down movement)
e	Joint #4 (rotation)
f	Shaft
g	Arm #2
h	Joint #1 (rotation)
i	Arm #1
j	Base
k	Conduit tube

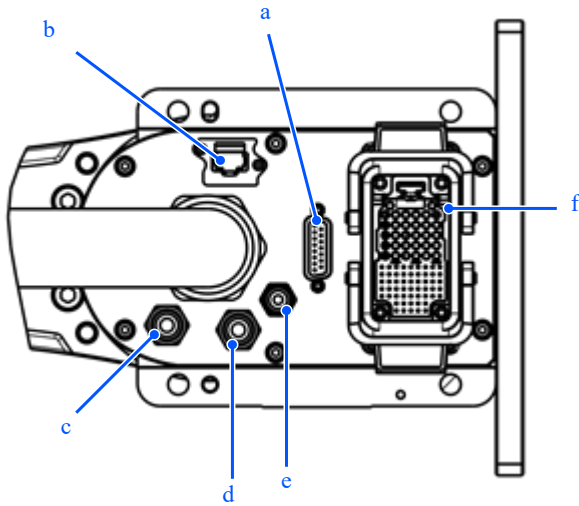

Symbol	Description
a	User connector (15-pin D-sub connector)
b	Ethernet connector
c	Fitting for ø6 mm tube (white)
d	Fitting for ø6 mm tube (blue)
e	Fitting for ø4 mm tube (blue)
f	M/C cable connector

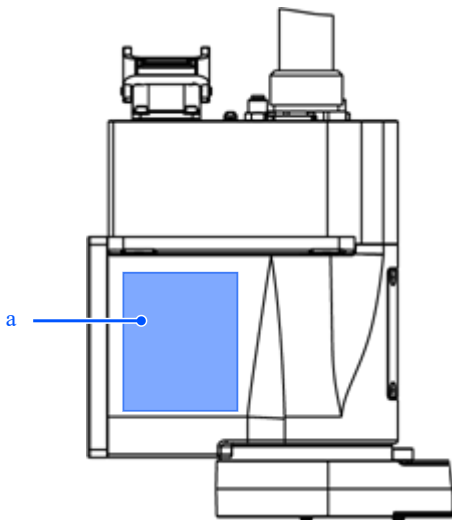

Symbol	Description
a	Face plate (serial number of Manipulator)

KEY POINTS

- The brake release switch is used with both Joint #3 and Joint #4. Press the brake release switch while in the emergency stop state to simultaneously release the brakes on Joint #3 and Joint #4.
- Before starting any maintenance work, be sure to turn off the Controller and inform others in the surrounding area that work is in progress. Performing any work procedure with the power turned on is extremely dangerous and may result in electric shock and/or malfunction of the robot system.

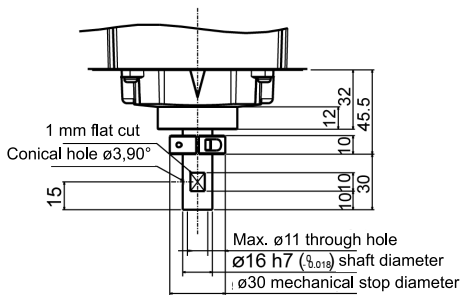
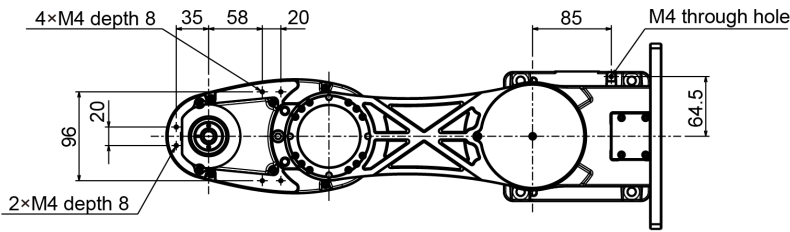
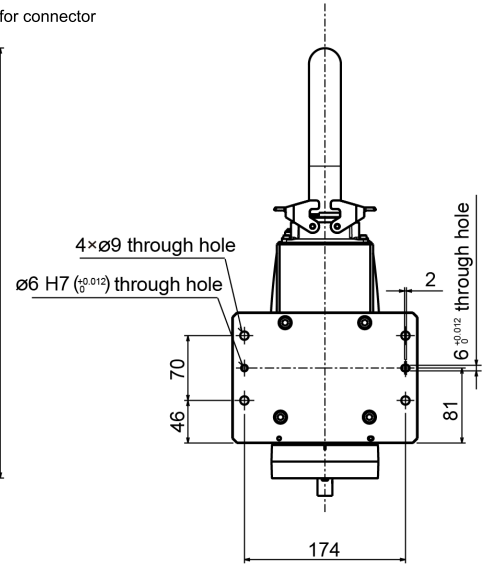
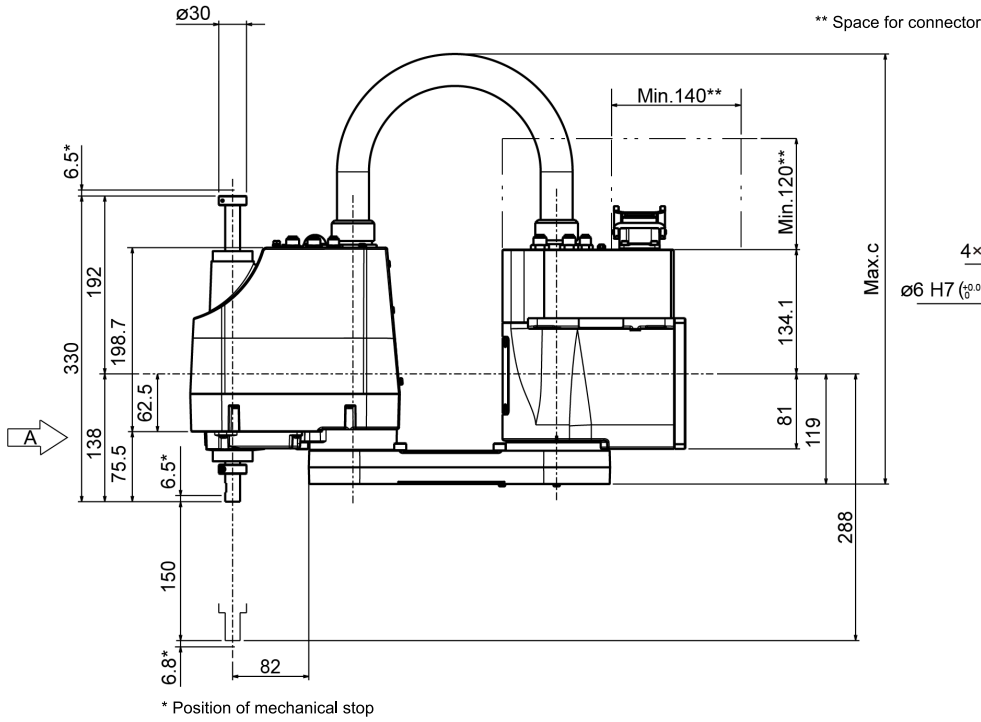
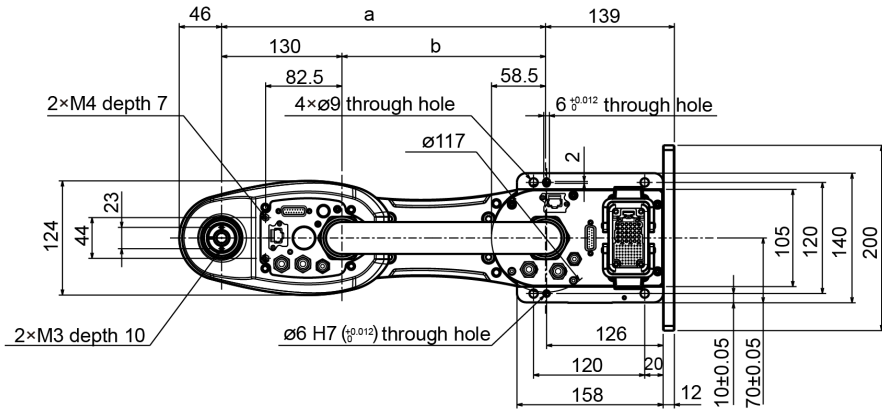

Details of A
Calibration point position of Joints #3 and #4

	GX4-A/GX4-B/ GX4-C301SM, EM	GX4-A/GX4-B/ GX4-C351SM, EM
a	300	350
b	170	220
c	475	500

ESD specifications GX4-A/GX4-B/GX4-C1EM**

The part shown below is different from the standard specifications. The external dimensions are identical.

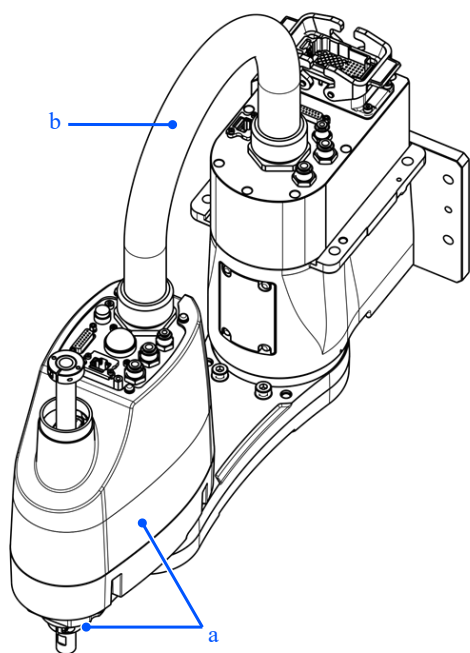

Symbol	Description
a	Plating covers (anti-static specifications)
b	Conduit Tube (anti-static specifications)

Cleanroom & ESD specifications GX4-A/GX4-B/GX4-C1CM**

The parts shown below differ from the standard specifications.

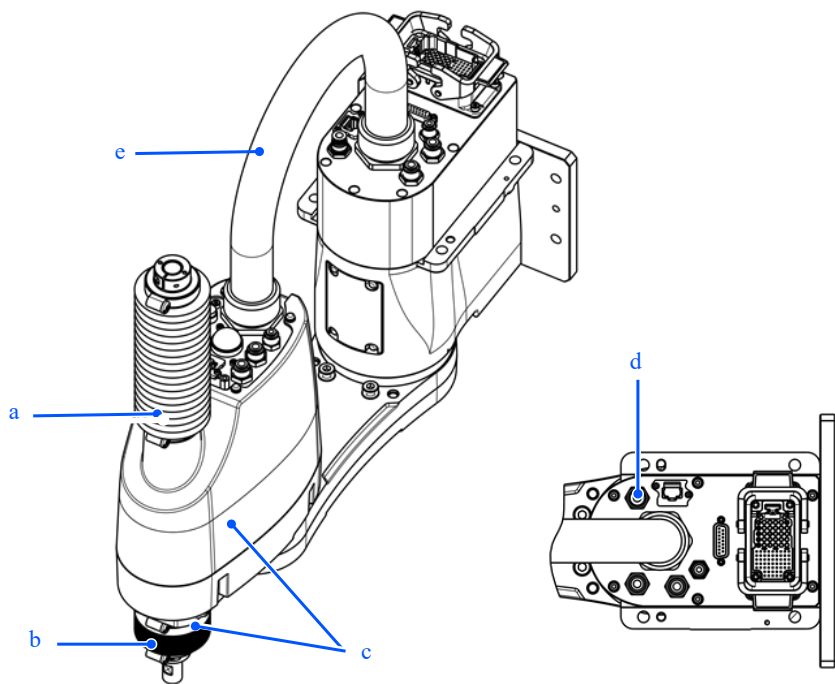

Symbol	Description
a	Upper bellows
b	Lower bellows
c	Plating covers (anti-static specifications)
d	Exhaust port
e	Conduit Tube (anti-static specifications)

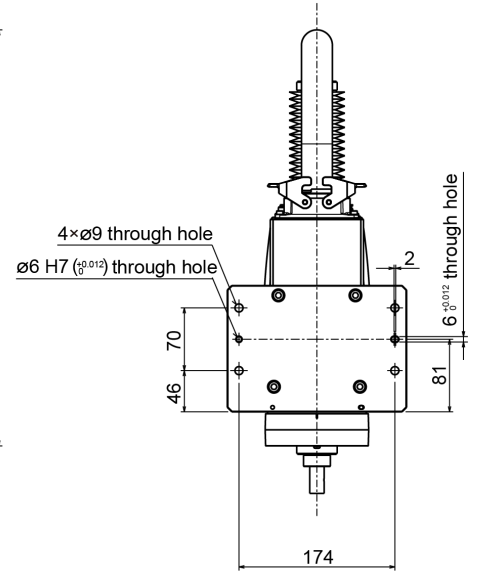
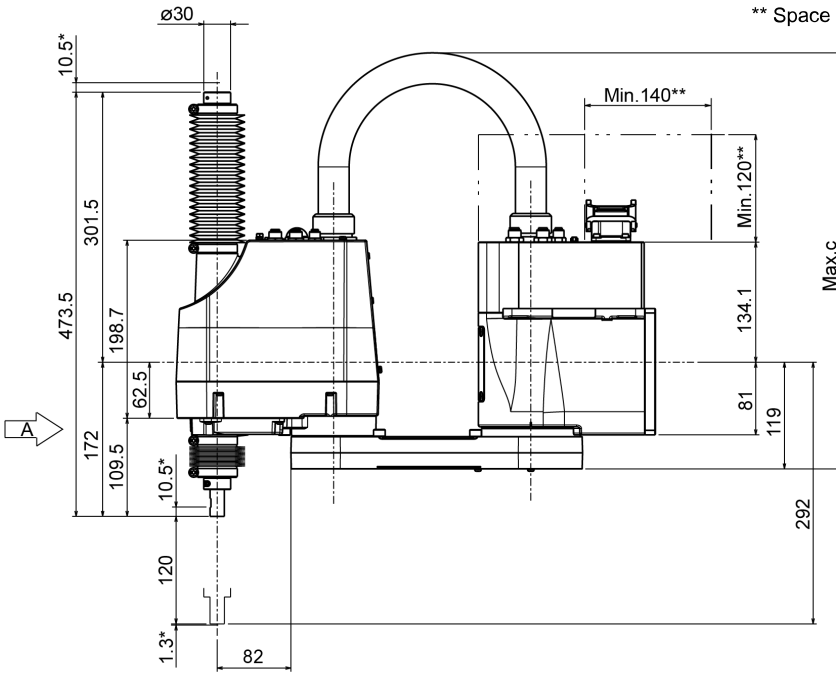
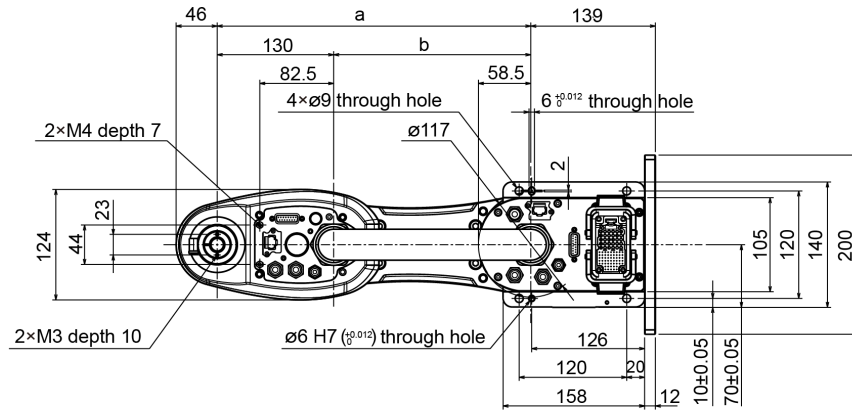

* Position of mechanical stop

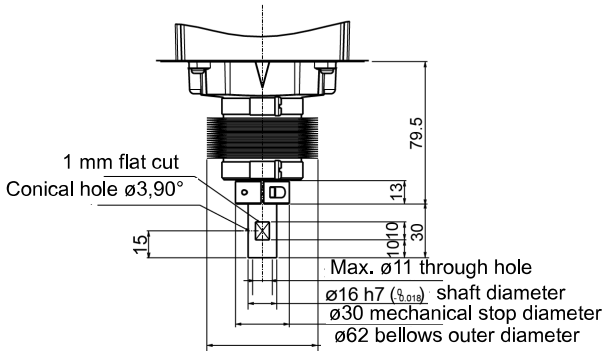
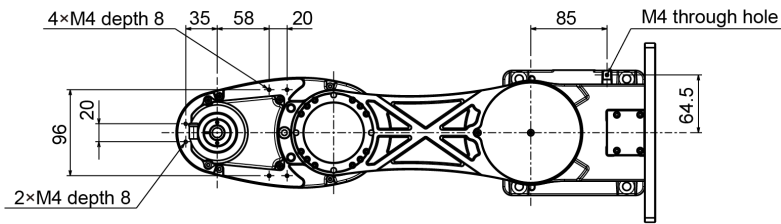

Details of A
Calibration point position of Joints #3 and #4

	GX4-A/GX4-B/ GX4-C301CM	GX4-A/GX4-B/ GX4-C351CM
a	300	350
b	170	220
c	475	500

2.2.5 Specifications Table

For the specifications tables of each model, refer to the following section.

[Appendix A: Specifications Table](#)

2.2.6 How to Set the Model

The Manipulator model for your system has been set before shipment from the factory.

Normally, the model does not need to be changed when you receive your system.

CAUTION

- If changing the setting of the Manipulator model, be responsible and absolutely certain that the wrong Manipulator model is not set. Incorrect setting of the Manipulator model may result in abnormal or no operation by the Manipulator and could even cause safety problems.

KEY POINTS

If a custom specifications number (MT^{***}) or (X^{***}) is written on the face plate (serial number label), the Manipulator has custom specifications.

Models with custom specifications may require a different setting procedure. Check the custom specifications number and contact the supplier for more information.

The Manipulator model is set from software. For details, refer to the following manual.

"Epson RC+ User's Guide - Robot Settings"

2.3 Environment and Installation

The robot system should be designed and installed by people who have received installation training provided by Epson and the suppliers. Also, the laws and regulations of the installation country must be followed.

2.3.1 Environment

To ensure that the robot system operates and maintains maximum performance and to ensure its safe use, the robot system should be installed in an environment that meets the following requirements.

Item	Requirement
Ambient temperature *1	Installation: 5 to 40°C Transport, storage: -20 to 60°C
Ambient relative humidity	Installation: 10 to 80% (no condensation) Transport, storage: 10 to 90% (no condensation)
Fast transient burst noise	1 kV or less (signal line)
Electrostatic noise	4 kV or less
Altitude	2,000 m or less
Environment	<ul style="list-style-type: none"> ▪ Install indoors. ▪ Keep away from direct sunlight. ▪ Keep away from dust, oily smoke, salinity, metal powder, and other contaminants. ▪ Keep away from flammable or corrosive liquids and gases. ▪ Keep away from water. ▪ Keep away from shocks or vibrations. ▪ Keep away from sources of electric noise. ▪ Keep away from explosive areas. ▪ Keep away from large quantities of radiation.

 **KEY POINTS**

Manipulators are not designed for use in adverse environments. If the Manipulator will be used in a location that does not meet the above requirements, please contact the supplier.

*1 The ambient temperature requirement is for the Manipulator only. For details on the environment requirements for the connected Controller, refer to the following manual.

"Controller Manual"

 **KEY POINTS**

When used in a low-temperature environment near the minimum temperature specified in the product specifications, or when the unit is idle for a long period of time during holidays or at night, a collision detection error or similar error may occur immediately after the start of operation due to high resistance in the drive unit. In such cases, warm-up operation for about 10 minutes is recommended.

KEY POINTS

If there are conductive objects such as fences or ladders within 2.5 m of the Manipulator, these objects must be grounded.

Special environmental requirements

Manipulator surfaces are generally oil-resistant, but if special oils are to be used, oil resistance should be checked before use. For more information, please contact the supplier.

In environments with rapid changes in temperature and humidity, condensation may form inside the Manipulator.

When handling food directly, it is necessary to make sure that the Manipulator is not likely to contaminate the food. For more information, please contact the supplier.

The Manipulator cannot be used in corrosive environments where acids or alkalis are present. In environments where rust can easily form, such as those exposed to salt, rust may also form on the Manipulator.

WARNING

Always use a circuit breaker for the Controller's power supply. Failure to use a circuit breaker may result in an electrical shock hazard or malfunction due to an electrical leakage.

Select the correct circuit breaker based on the Controller that you are using. For more information, refer to the following manual.

"Controller Manual"

CAUTION

- When cleaning the Manipulator, do not rub it strongly with alcohol or benzene. Coated surfaces may lose their luster.

2.3.2 Base Table

A base table for anchoring the Manipulator is not supplied. The base table must be fabricated or obtained by the customer.

The shape and size of the base table vary depending on the application of the robot system. As a reference when designing the base table, the requirements from the Manipulator side are shown here.

The base table must not only be able to bear the weight of the Manipulator but also be able to withstand the dynamic movement of the Manipulator when it operates at maximum acceleration/deceleration. Ensure that the base table has enough strength by using reinforcing materials such as crossbeams.

The torque and reaction force produced by the movement of the Manipulator are as follows:

- Maximum torque on horizontal surface: 500 N·m
- Maximum reaction force in horizontal direction: 2,000 N
- Maximum reaction force in vertical direction: 1,000 N

M8 threaded holes are used for mounting the Manipulator on the base table.

Use bolts for mounting the Manipulator that have a strength compliant with ISO 898-1 property class 10.9 or 12.9. For details

on the dimensions, refer to the following sections.

Names of Parts and Their Dimensions

Manipulator Mounting Dimensions

The plate for the Manipulator mounting face should be at least 20 mm thick and made of steel for reducing vibrations. A surface roughness of 25 µm or less at the maximum height is appropriate.

The base table must be secured to the floor or wall to prevent it from moving.

The Manipulator mounting surface should have a flatness of 0.5 mm or less and an inclination of 0.5° or less to a horizontal or vertical surface. If the installation surface does not have the proper flatness, the base of the Manipulator may be damaged or the robot may be unable to operate at maximum performance.

When using a leveler to adjust the height of the base table, use a screw with M16 diameter or more.

If passing cables through the holes in the base table, refer to the connector dimensions in the figures below.

(Units: mm)

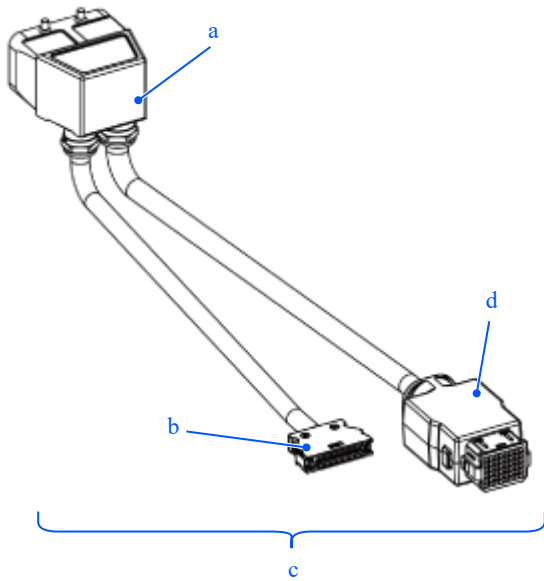

Symbol	Description
a	M/C cable hood
b	Signal connector
c	M/C cable
d	Power connector

Signal Connector	Power Connector (Straight)	Power Connector (L-shaped)

For details on the environmental requirements for the space when housing the Controller in the base table, refer to the following manual.

"Controller Manual"

WARNING

To ensure safety, be sure to install safety barriers for the robot system. For details, refer to the following section.

[Safeguard \(SG\)](#)

2.3.3 Manipulator Mounting Dimensions

The maximum envelope of the Manipulator is shown in the figures below. The maximum envelope shown in each figure includes the 60 mm radius of the hand. If the radius of the hand exceeds 60 mm, define the radius as the distance to the outer edge of the maximum envelope. In addition to the hand, if a camera, solenoid valve, or other component attached to the arm is large, set the maximum envelope to include the range that the component may reach.

Also, besides the area required for installation of the Manipulator, Controller, peripheral equipment, and other devices, the following space should be provided at a minimum.

- Space for teaching
- Space for maintenance and inspection (Space for working safely in the safety barriers)
- Space for cables

KEY POINTS

- When installing the cables, be sure to maintain sufficient distance from obstacles.
- For the minimum bend radius of the M/C cable, refer to the following section.

GX4

- Also, leave enough space for other cables so that they are not forced to bend at extreme angles.

WARNING

Install the Manipulator in a location with enough space so that a tool or a workpiece tip does not reach a wall or safety barriers when the Manipulator extends its arm while holding a workpiece. If the tool or the workpiece tip reaches a wall or safety barriers, it is extremely hazardous and may result in serious bodily injury to operators and/or severe equipment damage.

The distance between the safety barriers and the tool or workpiece should be set according to ISO 10218-2.

For the stopping time and stopping distance, refer to the following sections.

[Appendix B: Stopping Time and Stopping Distance at Emergency Stop](#)

[Appendix C: Stopping Time and Stopping Distance When Safeguard is Open](#)

Table top mounting specifications - Straight arm

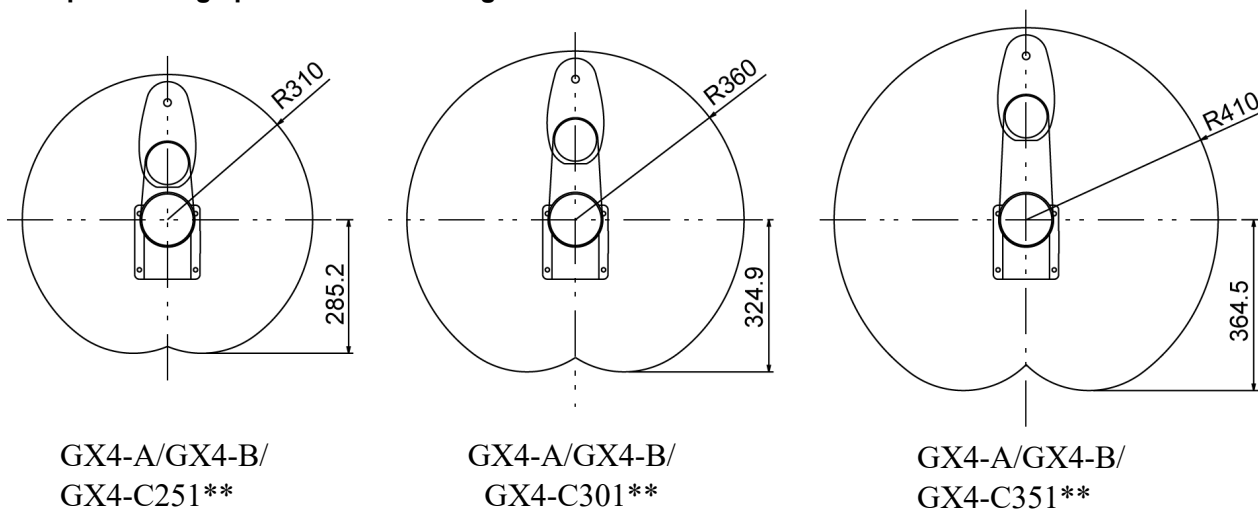
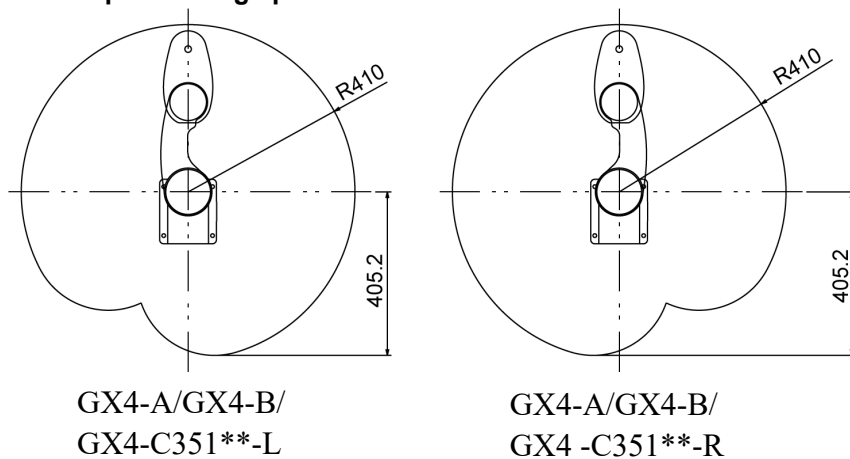
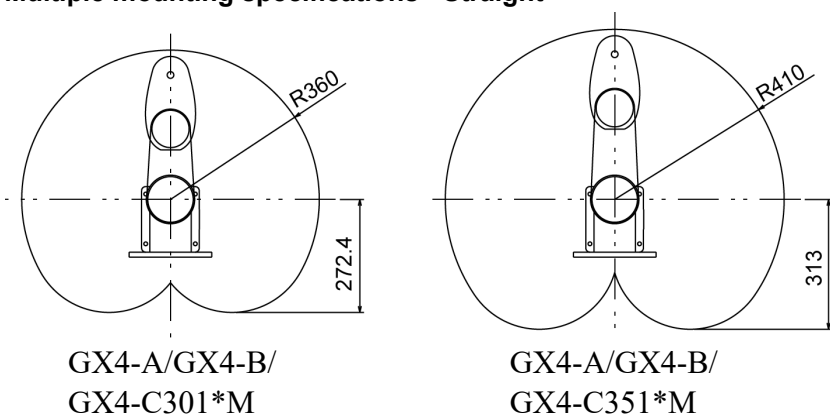

Table top mounting specifications - Curved arm



Multiple mounting specifications - Straight



2.3.4 From Unpacking to Installation

2.3.4.1 Safety Information for the Flow from Unpacking to Installation

Transportation and installation of the Manipulator and related equipment should be performed by people who have received installation training provided by Epson and the suppliers. Also, the laws and regulations of the installation country must be followed.

WARNING

- Only qualified personnel should perform sling work and operate a crane or a forklift. When these operations are performed by unqualified personnel, it is extremely hazardous and may result in serious bodily injury to operators and/or severe equipment damage.

CAUTION

- Use a cart or the like to transport the Manipulator in the same status as it was delivered.
- After removing the fixing bolts securing the Manipulator to the transportation pallet, the Manipulator can fall. Be careful not to get your hands or feet caught in between the Manipulator.
- The Manipulator should be transported by two or more people, either secured to transporting equipment or carried by placing their hands under Arm #1 or the bottom of the base.

When holding the bottom of the base by hand, be extremely careful not to get your hands or fingers caught.

Table top mounting

- GX4-A/GX4-B/GX4-C251**: Approx. 15 kg (33 lb)
- GX4-A/GX4-B/GX4-C301**: Approx. 15 kg (33 lb)
- GX4-A/GX4-B/GX4-C351**: Approx. 16 kg (35 lb)

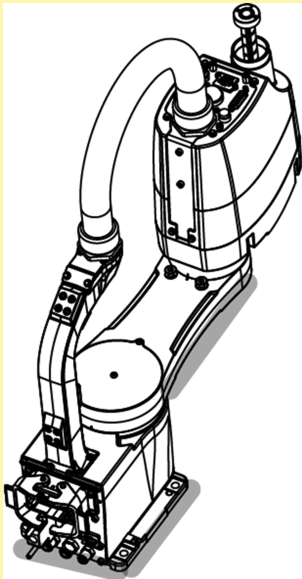

Multiple mounting

- GX4-A/GX4-B/GX4-C301*M: Approx. 17 kg (38 lb)

- GX4-A/GX4-B/GX4-C351*M: Approx. 17 kg (38 lb)

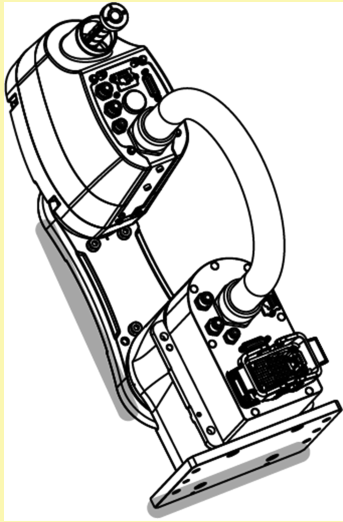

- When transporting the Manipulator over long distances, secure it directly to transporting equipment so that it will not fall. If necessary, pack the Manipulator using the same packaging as delivery.

⚠ CAUTION

- The Manipulator must be installed to avoid interference with surrounding buildings, structures, and other machines and equipment that may create a trapping hazard or pinch points.
- Resonance (resonating sound or minute vibrations) may occur during Manipulator operation depending on the rigidity of the base table. If the resonance occurs, improve the rigidity of the base table or change the speed or acceleration and deceleration settings of the Manipulator.

For details on the Manipulator installation procedure for models with standard specifications and ESD specifications, refer to the following sections.

- Table Top Mounting Specifications
- Multiple Mounting Specifications

For Manipulator models with cleanroom & ESD specifications, refer to the following section.

- Cleanroom & ESD Specifications

2.3.4.2 Table Top Mounting Specifications

⚠ CAUTION

- Be sure to always use two or more people when installing or relocating the model with table top mounting specifications. The Manipulator weights are as follows. Be careful not to get hands or feet caught or have equipment damaged due to dropping of the Manipulator.
 - GX4-A/GX4-B/GX4-C251**: Approx. 15 kg (33 lb)
 - GX4-A/GX4-B/GX4-C301**: Approx. 15 kg (33 lb)
 - GX4-A/GX4-B/GX4-C351**: Approx. 16 kg (35 lb)

1. With the arm extended, take out the Manipulator from the packing box.

KEY POINTS

When taking out the Manipulator from the packing box, be sure that the Manipulator does not drop or fall because it is not secured in place.

The joints of the Manipulator may rotate due to their own weight. Be careful not to get your hands or fingers caught.

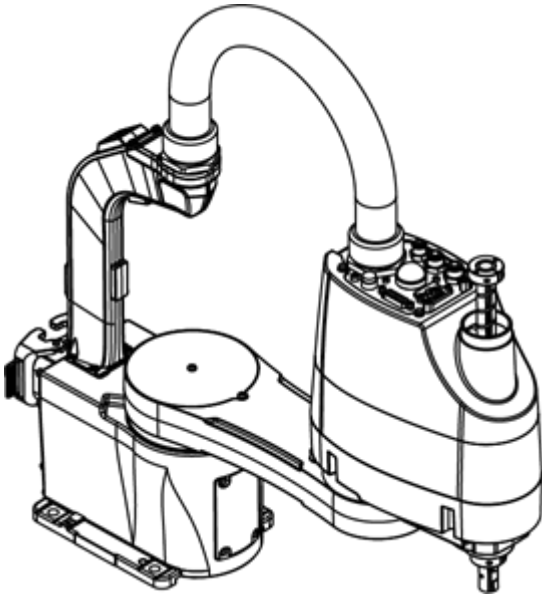

- Secure the base to the base table using four bolts. Be sure to always use washers. Tightening torque: 32.0 N·m (326 kgf·cm)

KEY POINTS

Use bolts with strength specifications compliant with ISO 898-1 property class: 10.9 or 12.9.

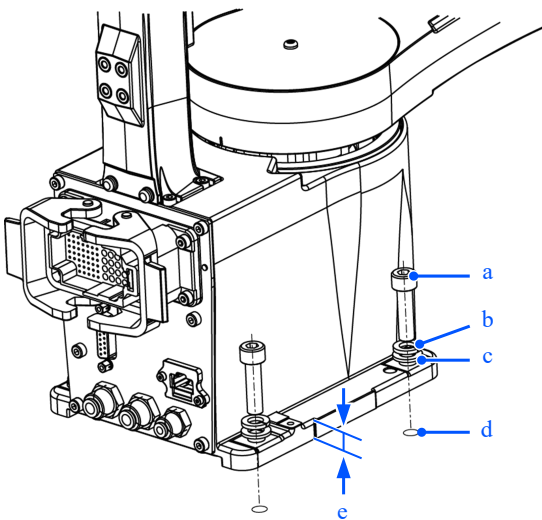

Symbol	Description
a	4 × M8 × 30
b	Spring washer

Symbol	Description
c	Plain washer
d	4 × M8 threaded hole (20 mm or more depth)
e	10 mm

KEY POINTS

If the cable is routed by exiting from the bottom side, make sure there is enough space in the center of the base table where the base will be secured in place.

Height: 190 mm min.

Width: 104 mm

Depth: 190 mm or more

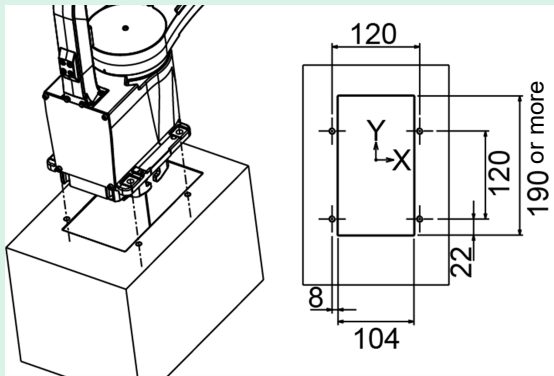

2.3.4.3 Multiple Mounting Specifications

⚠ WARNING

- Be sure to always use two or more people when installing or relocating the model with multiple mounting specifications. The Manipulator weights are as follows. Be careful not to get hands or feet caught or have equipment damaged due to dropping of the Manipulator.
 - GX4-A/GX4-B/GX4-C301*M: Approx. 17 kg (38 lb)
 - GX4-A/GX4-B/GX4-C351*M: Approx. 17 kg (38 lb)
- When installing the Manipulator on a wall or similar structure, support the Manipulator until all of the anchor bolts are secured in place. Removing the support before the anchor bolts are fully secured is extremely hazardous and may cause the Manipulator to fall.

KEY POINTS

Fabricate the base table for installing the Manipulator with multiple mounting specifications so that it does not touch any cable and conduit tube connected to the Manipulator.

The recommended installation methods are as follows:

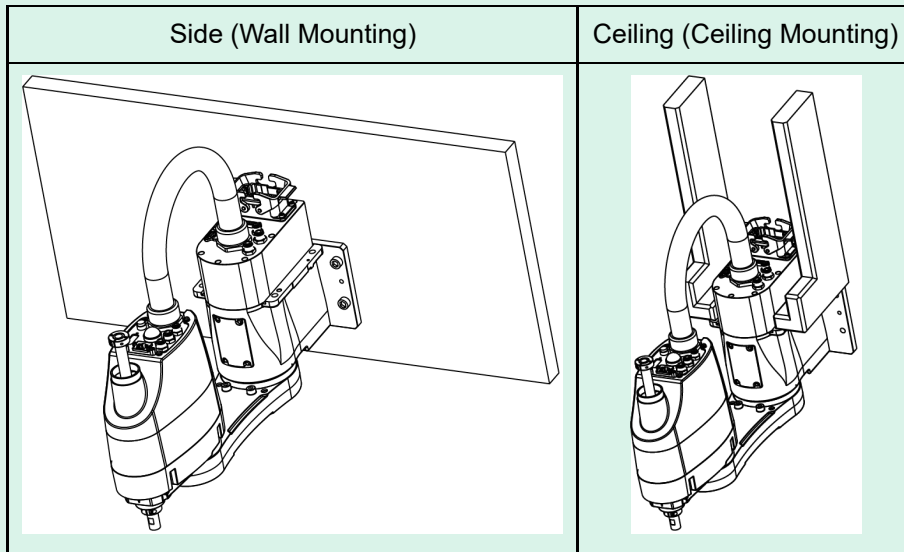

The recommended wall mounting method is described below.

1. With the arm extended, take out the Manipulator from the packing box.

When taking out the Manipulator from the packing box, be sure that the Manipulator does not drop or fall because it is not secured in place.

The joints of the Manipulator may rotate due to their own weight. Be careful not to get your hands or fingers caught.

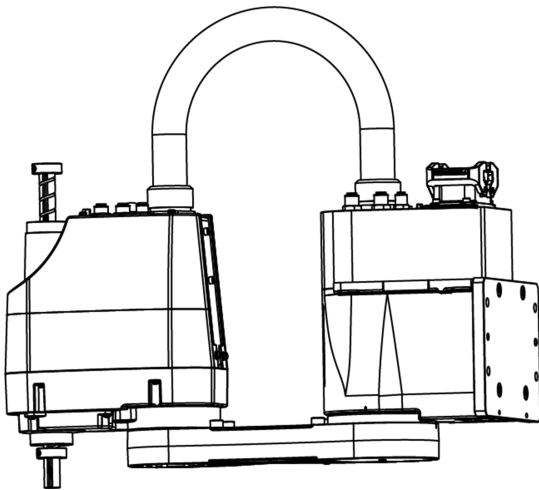

2. Secure the base to the wall using four bolts. Be sure to always use washers.

Tightening torque: 32.0 N·m (326 kgf·cm)

KEY POINTS

Use bolts with strength specifications compliant with ISO 898-1 property class: 10.9 or 12.9.

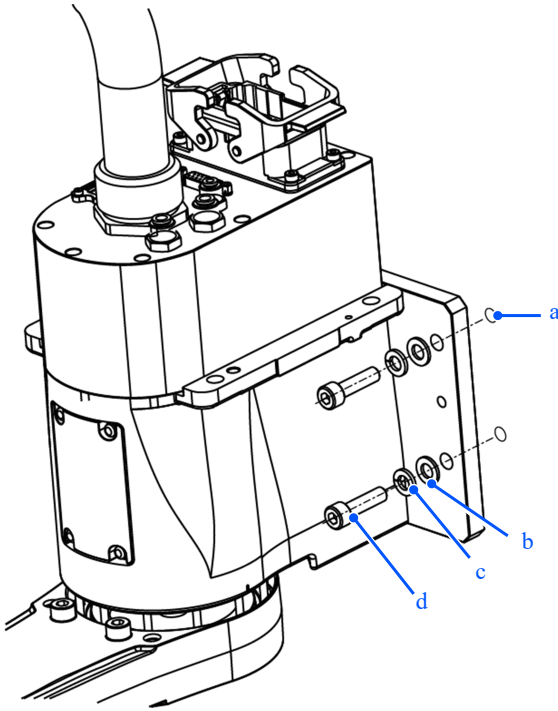

Symbol	Description
a	4 × M8 threaded hole (20 mm or more depth)
b	Plain washer
c	Spring washer
d	4 × M8 × 30

2.3.4.4 Cleanroom & ESD Specifications

1. Unpack the Manipulator outside of the cleanroom.
2. Secure the Manipulator to transporting equipment (or a pallet) with bolts so that the Manipulator does not fall down.
3. Wipe off any dust on the Manipulator using a lint-free cloth that was dipped in ethyl alcohol or distilled water.
4. Carry the Manipulator into the cleanroom.
5. Refer to the installation procedure for the respective Manipulator model, and install the Manipulator.
 "Table Top Mounting Specifications"
 "Multiple Mounting Specifications"
6. Connect an exhaust tube to the exhaust port.

When the Manipulator is a model with cleanroom & ESD specifications, an exhaust system must be connected. The exhaust system is described in the following section.

[Appendix A: Specifications Table](#)

2.3.5 Connecting the Cables

WARNING

- To perform the power supply lockout, remove the power plug. Be sure to connect the AC power cable to a power outlet. Do not connect it directly to a factory power source.
- Before performing any replacement work, inform others in the area that you are working, and then turn off the Controller and related equipment, and unplug the power cable from the power source. Performing any work procedure with the power turned on is extremely dangerous and may result in electric shock and/or malfunction of the robot system.
- Be sure to connect the cables properly. Do not put heavy objects on the cables, bend or pull on the cables forcibly, or allow the cables to be pinched. Damaged cables, broken wires, or contact failure is extremely hazardous and may result in electric shock and/or malfunction of the robot system.
- The Manipulator is grounded by connecting it to the Controller. Ensure that the Controller is grounded and the cables are correctly connected. If the ground wire is improperly connected to ground, it may result in the fire or electric shock.
- Be sure to turn off the power and tag out (e.g., with a "DO NOT TURN ON" sign) before performing wiring. Performing any work procedure with the power turned on is extremely dangerous and may result in electric shock and/or malfunction of the robot system.

CAUTION

- When connecting the Manipulator and the Controller, check that the serial numbers match for each device. Improper connection between the Manipulator and the Controller may not only lead to malfunction of the robot system but also serious safety problems. The connection method between the Manipulator and the Controller varies depending on the Controller. For details on the connections, refer to the following manual.

"Controller Manual"

When the Manipulator is a model with cleanroom & ESD specifications, please note the following points.

When the Manipulator is a model with cleanroom & ESD specifications, an exhaust system must be connected. The exhaust system is described in the following section.

[Appendix A: Specifications Table](#)

Connection procedure for Manipulator and M/C cable

Insert the M/C cable hood into the M/C cable housing on the back and bottom of the Manipulator, and secure it with the lock attached to the housing.

1. Open the lock plates on both sides of the M/C cable housing.
2. Insert the M/C cable hood all the way to the back.
3. Close the lock plates on both sides of the M/C cable housing.

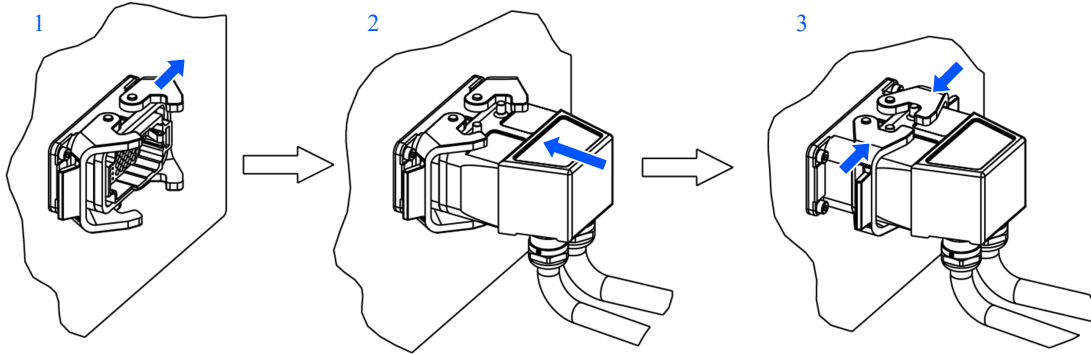

L-shape (Standard)		Straight	
Minimum Distance Required for Insertion and Removal	Distance When Mounted	Minimum Distance Required for Insertion and Removal	Distance When Mounted
<p>120mm</p>	<p>100mm</p>	<p>210mm</p>	<p>190mm</p>

Connecting the M/C cable and the Controller

Connect the power connector and signal connector of the M/C cable to the Controller.

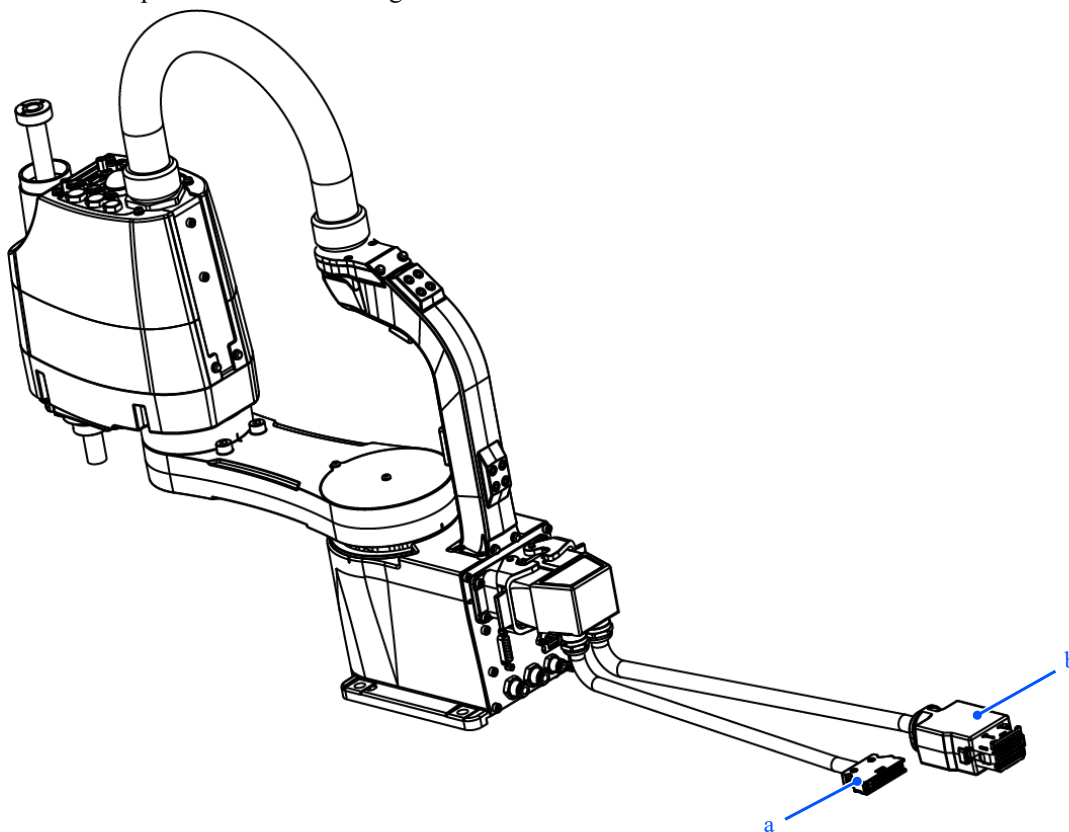

Symbol	Description
a	Signal connector
b	Power connector

There are two types of M/C cables: fixed and movable. Movable cables have wires as shown in the figure below.



2.3.6 User Wires and Pneumatic Tubes

⚠ WARNING

- Be sure to turn off the power and tag out (e.g., with a "DO NOT TURN ON" sign) before performing wiring. Performing any work procedure with the power turned on is extremely dangerous and may result in electric shock and/or malfunction of the robot system.

⚠ CAUTION

- Only authorized or certified staff should be allowed to perform wiring. Wiring by unauthorized or uncertified staff may result in bodily injury and/or malfunction of the robot system.

2.3.6.1 Electrical Wires

Connect the following connectors and cables to the user connector of the Manipulator.

Manipulator cable specifications

	Rated Voltage	Allowable Current	Nominal Cross-sectional Area of Conductor	Remarks
D-sub 15 pin	30V AC/DC	1.0 A	0.08 mm ²	Shielded
RJ45	-	-	-	Equivalent to CAT5e

For each connector, pins with the same number are wired between the connector on the base side and the connector on the Arm #2 side in the Manipulator.

Attached connector for user wires

		Manufacturer	Model Number	Type	Remarks
D-sub 15 pin	Connector	Würth Elektronik	61801524823	Solder type	2 included
	Clamp hood	Würth Elektronik	61801525311	Connector setscrew: #4-40 UNC	2 included

- 8-pin (RJ45) equivalent to Cat.5e
An Ethernet cable (commercially available) can be connected to Manipulator models with standard and cleanroom & ESD specifications.

2.3.6.2 Pneumatic Tubes

Manipulator pneumatic tube specifications

Maximum Working Pressure	Number of Tubes	O.D. × I.D.
0.59 Mpa (6 kgf/cm ² : 86 psi)	2	ø6 mm × ø4 mm
	1	ø4 mm × ø2.5 mm

Inside the Manipulator, fittings of the same size and tip color (blue/white) are connected between the air fitting on the base side and the air fitting on the Arm #2 side.

Arm #2 side (common to GX4 series)

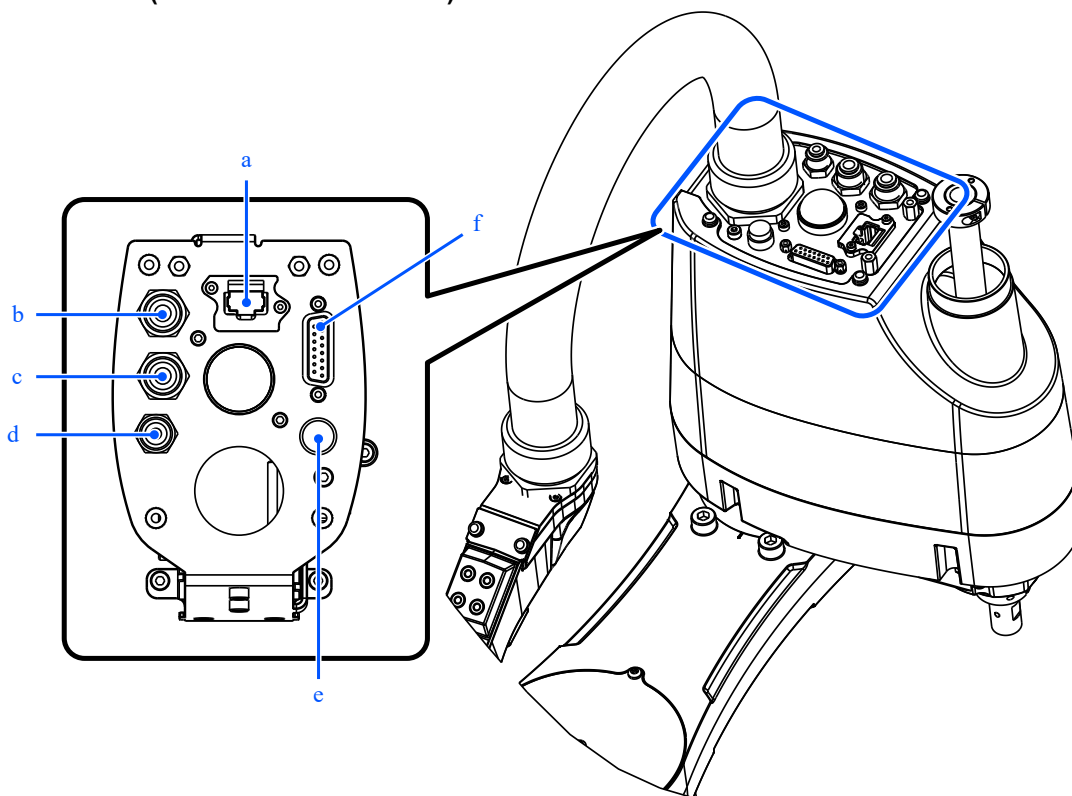

Symbol	Description
a	Ethernet connector
b	Fitting for ø6 mm tube (white)
c	Fitting for ø6 mm tube (blue)
d	Fitting for ø4 mm tube (blue)
e	Brake release switch
f	User connector (15-pin D-sub connector)

Base side (table top mounting specifications: cable routing from bottom side)

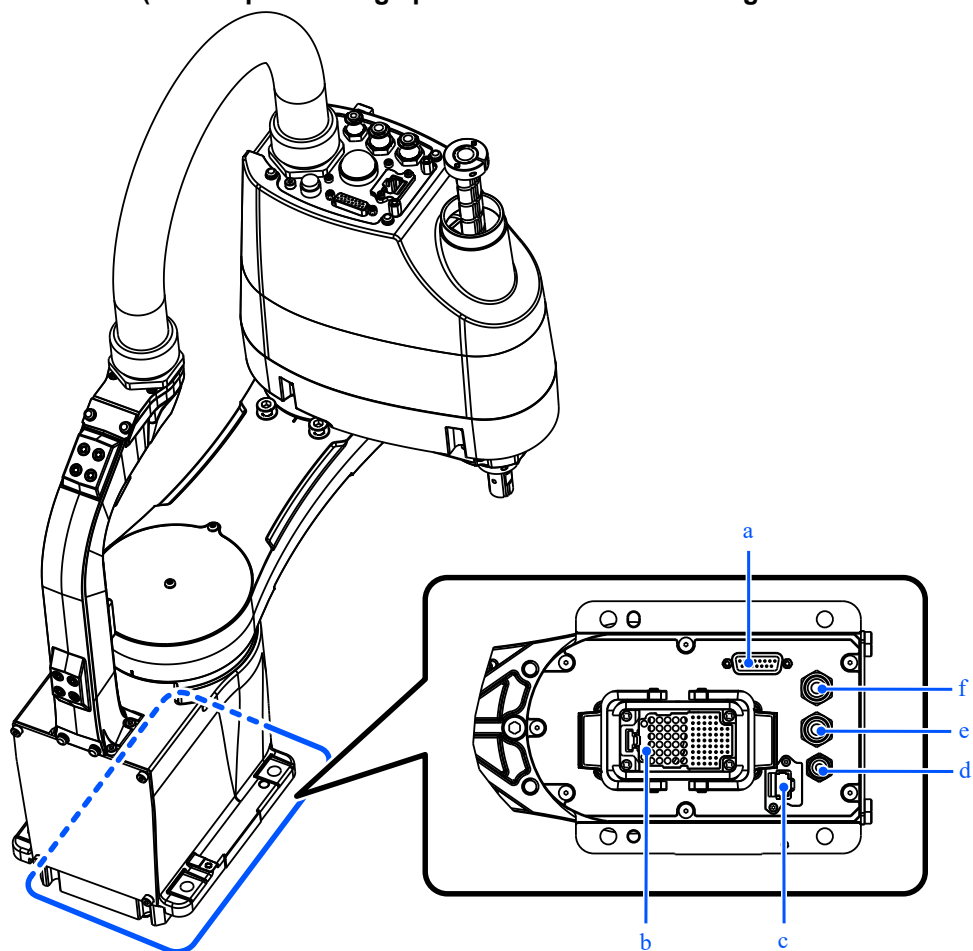

Symbol	Description
a	User connector (15-pin D-sub connector)
b	M/C cable housing
c	Ethernet connector
d	Fitting for ø4 mm tube (blue)
e	Fitting for ø6 mm tube (blue)
f	Fitting for ø6 mm tube (white)

Base side (table top mounting specifications)

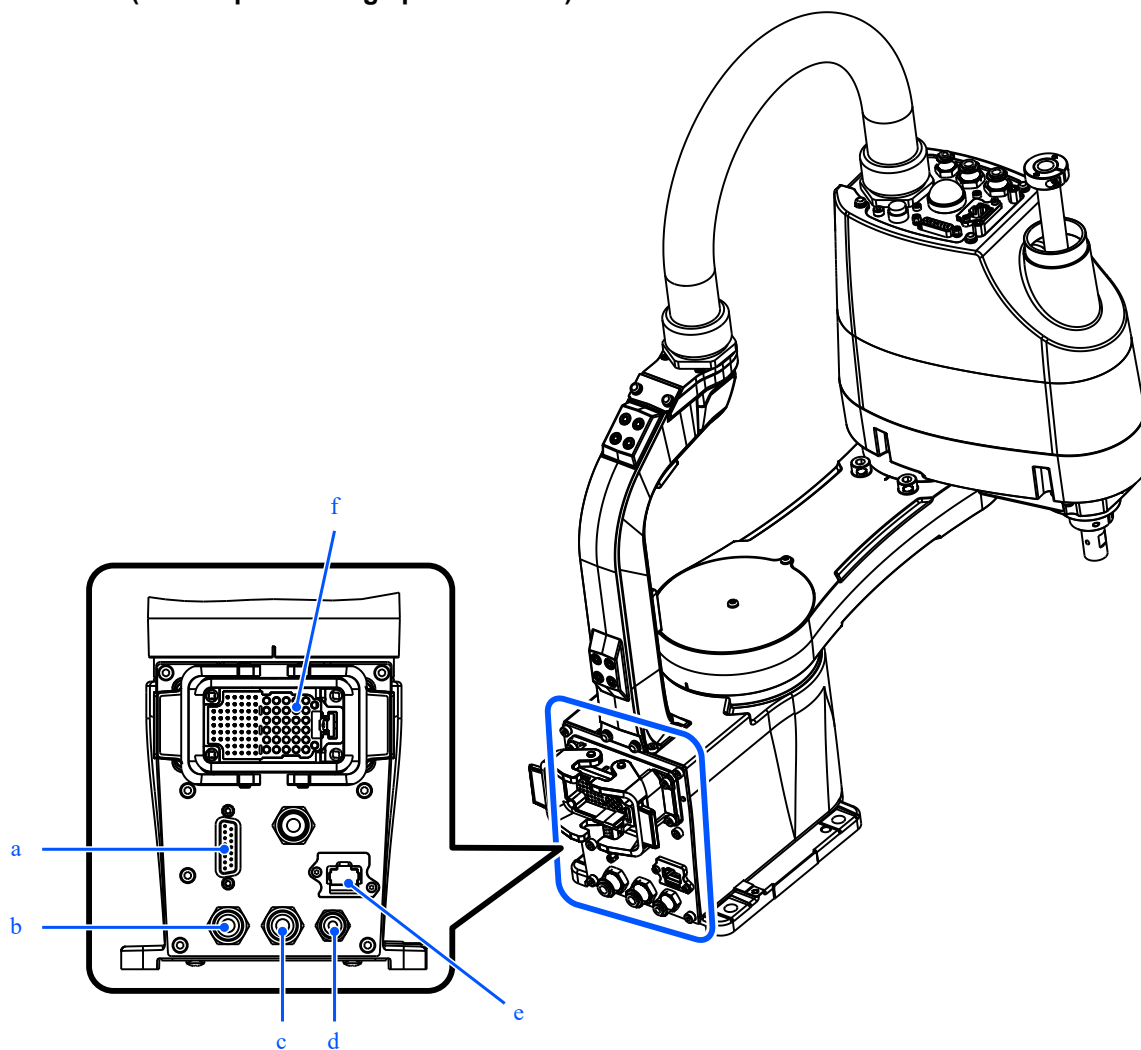

Symbol	Description
a	User connector (15-pin D-sub connector)
b	Fitting for ø6 mm tube (white)
c	Fitting for ø6 mm tube (blue)
d	Fitting for ø4 mm tube (blue)
e	Ethernet connector
f	M/C cable housing

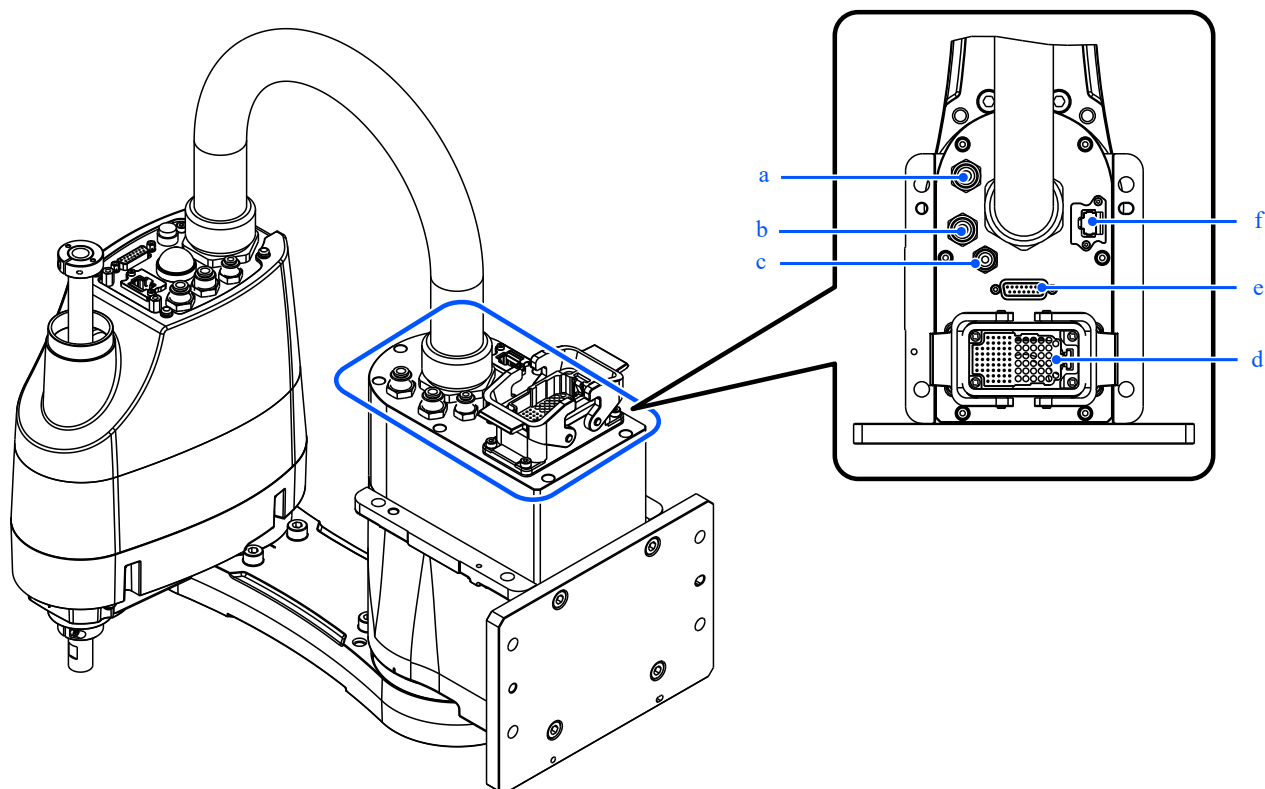
Base side (multiple mounting specifications)

Symbol	Description
a	Fitting for $\varnothing 6$ mm tube (white)
b	Fitting for $\varnothing 6$ mm tube (blue)
c	Fitting for $\varnothing 4$ mm tube (blue)
d	M/C cable housing
e	User connector (15-pin D-sub connector)
f	Ethernet connector

2.3.7 Relocation and Storage**2.3.7.1 Safety Information for Relocation and Storage**

Pay attention to the following requirements when relocating, storing, and transporting the Manipulators.

Transportation and installation of the Manipulator and related equipment should be performed by people who have received

installation training provided by Epson and the suppliers. Also, the laws and regulations of the installation country must be followed.

WARNING

- Only qualified personnel should perform sling work and operate a crane or a forklift. When these operations are performed by unqualified personnel, it is extremely hazardous and may result in serious bodily injury to operators and/or severe equipment damage.

CAUTION

- Before relocating, fold the arm and secure it tightly with a cable tie to prevent hands or fingers from getting caught in the Manipulator.
- When removing the anchor bolts, support the Manipulator so that it does not fall. Removing the anchor bolts without supporting the Manipulator can cause it to fall, causing hands or feet to get caught.
- The Manipulator should be transported by two or more people, either secured to transporting equipment or carried by placing their hands under Arm #1 or the bottom of the base. When holding the bottom of the base by hand, be extremely careful not to get your hands or fingers caught.

When transporting the Manipulator over long distances, secure it directly to transporting equipment so that it will not fall. If necessary, pack the Manipulator using the same packaging as delivery.

When the Manipulator is reassembled and used for a robot system again after an extended period of storage, perform a test run to verify that it works properly before starting the main operation.

Manipulators should be transported and stored under the following conditions: Temperature: -20 to +60°C, Humidity: 10 to 90% (no condensation).

If condensation has formed on the Manipulator during transportation or storage, do not turn on the power until the condensation is removed.

Do not subject the Manipulator to excessive impacts or vibrations during the transportation process.

2.3.7.2 Table Top Mounting Specifications

CAUTION

- Be sure to always use two or more people when installing or relocating the model with table top mounting specifications. The Manipulator weights are as follows. Be careful not to get hands or feet caught or have equipment damaged due to dropping of the Manipulator.
 - GX4-A/GX4-B/GX4-C251**: Approx. 15 kg (33 lb)
 - GX4-A/GX4-B/GX4-C301**: Approx. 15 kg (33 lb)
 - GX4-A/GX4-B/GX4-C351**: Approx. 16 kg (35 lb)

1. Turn off all power, and remove the wiring and tubes connected to the Manipulator.

KEY POINTS

If using variable mechanical stops for Joints #1 and #2 and the operating angle is limited, change to the mechanical stop positions at factory shipping.

Setting the Work Envelope by Mechanical Stops

2. Wrap a sheet around the arm so that it will not get damaged. Refer to the figure below, and use a cable tie or similar object to bind the lower end of the shaft and the arm, and the base and the arm so that the shaft does not sag down.

Example of securing arm in place

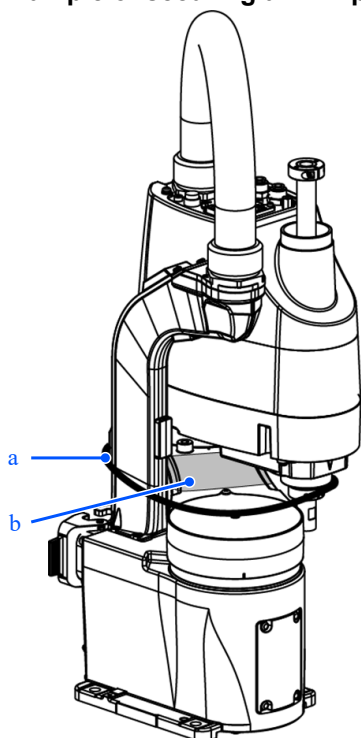

Symbol	Description
a	Cable tie
b	Sheet

3. While supporting the bottom of Arm #1 by hand so that the Manipulator does not fall over, remove the anchor bolts. Then, remove the Manipulator from the base table.

GX4-A/GX4-B/GX4-C251**

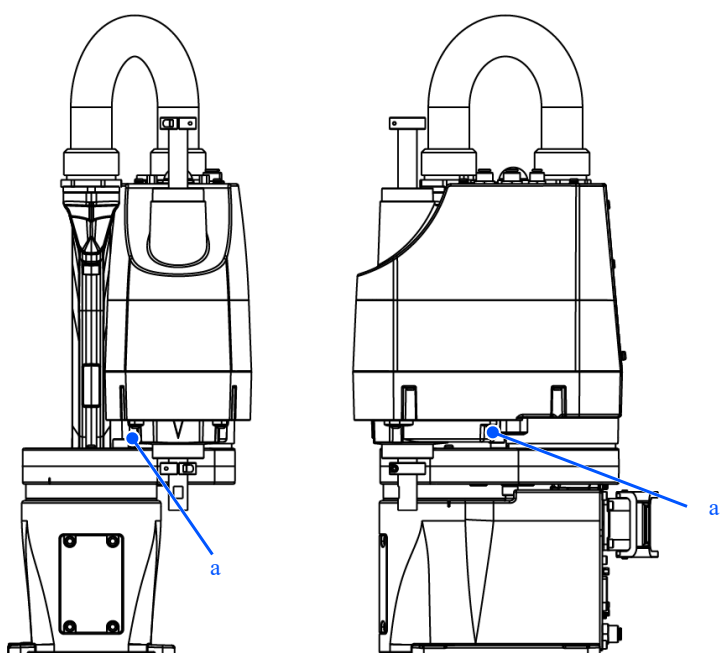

Symbol	Description
a	Center of gravity

GX4-A/GX4-B/GX4-C301**

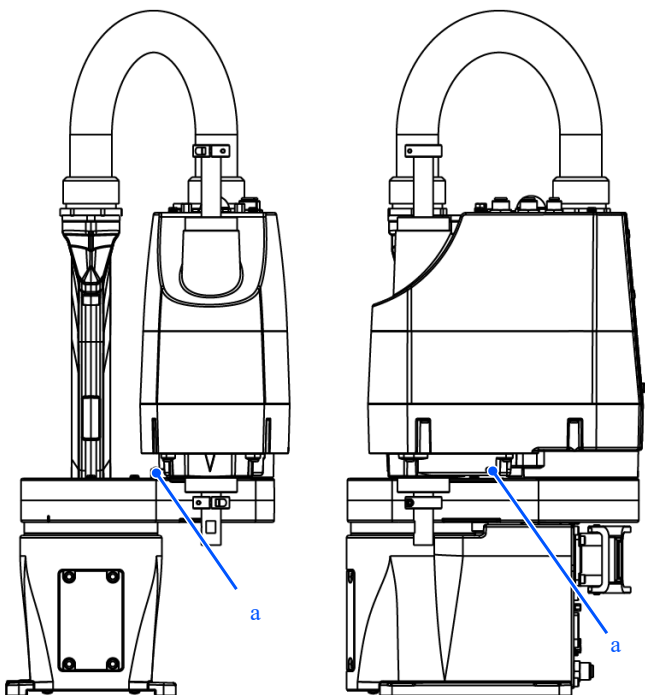

Symbol	Description
a	Center of gravity

GX4-A/GX4-B/GX4-C351**

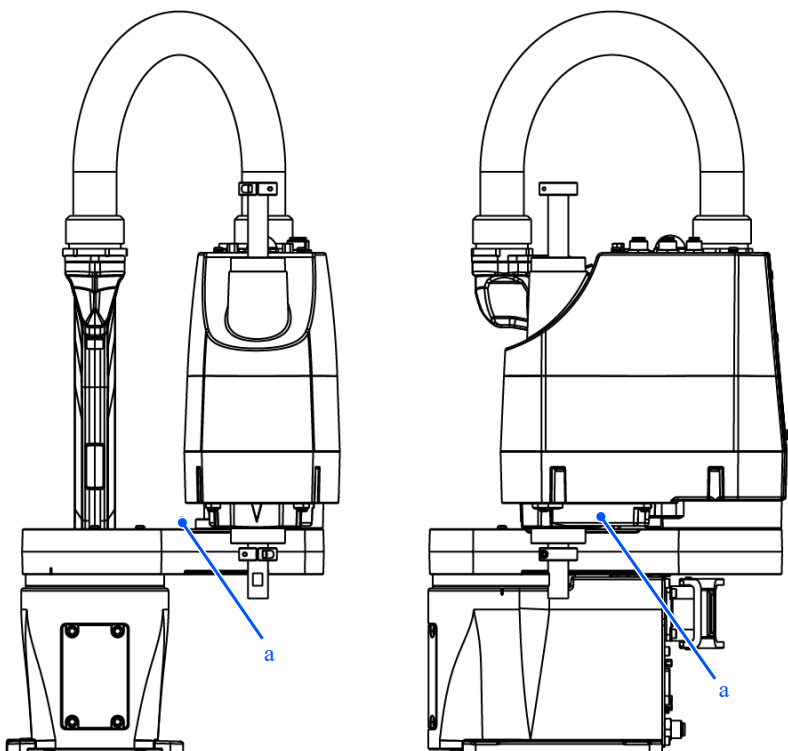

Symbol	Description
a	Center of gravity

2.3.7.3 Multiple Mounting Specifications

⚠ WARNING

- Be sure to always use two or more people when installing or relocating the model with multiple mounting specifications. The Manipulator weights are as follows. Be careful not to get hands or feet caught or have equipment damaged due to dropping of the Manipulator.
 - GX4-A/GX4-B/GX4-C301*M: Approx. 17 kg (38 lb)
 - GX4-A/GX4-B/GX4-C351*M: Approx. 17 kg (38 lb)
- When removing the Manipulator from a wall or other location, be sure to support the Manipulator before removing the anchor bolts. Removing the anchor bolts without supporting the Manipulator is extremely hazardous and may cause the Manipulator to fall.

1. Turn off all power, and remove the wiring and tubes connected to the Manipulator.

✎ KEY POINTS

If using variable mechanical stops for Joints #1 and #2 and the operating angle is limited, change to the mechanical stop positions at factory shipping.

Setting the Work Envelope by Mechanical Stops

2. Wrap a sheet around the arm so that it will not get damaged. Secure the arm while referring to the figure.

Example of securing arm in place

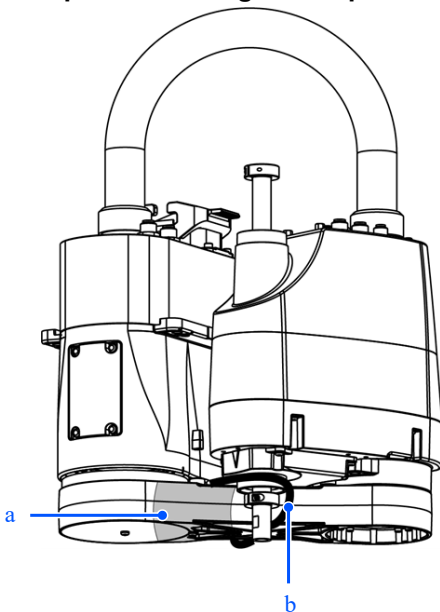

Symbol	Description
a	Sheet

Symbol	Description
b	Cable tie

- While supporting the bottom of Arm #1 by hand so that the Manipulator does not fall over, remove the anchor bolts. Then, remove the Manipulator from the wall.

GX4-A/GX4-B/GX4-C301*M

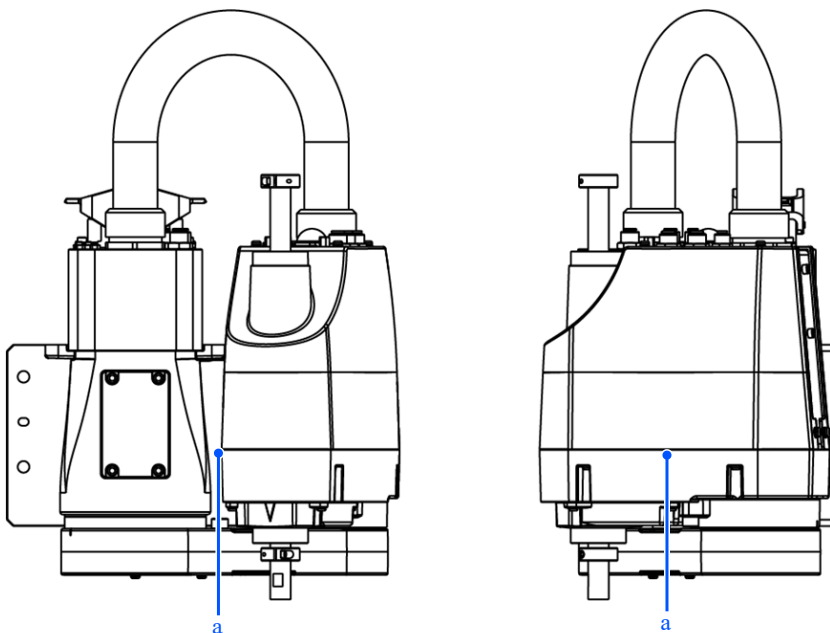

Symbol	Description
a	Center of gravity

GX4-A/GX4-B/GX4-C351*M

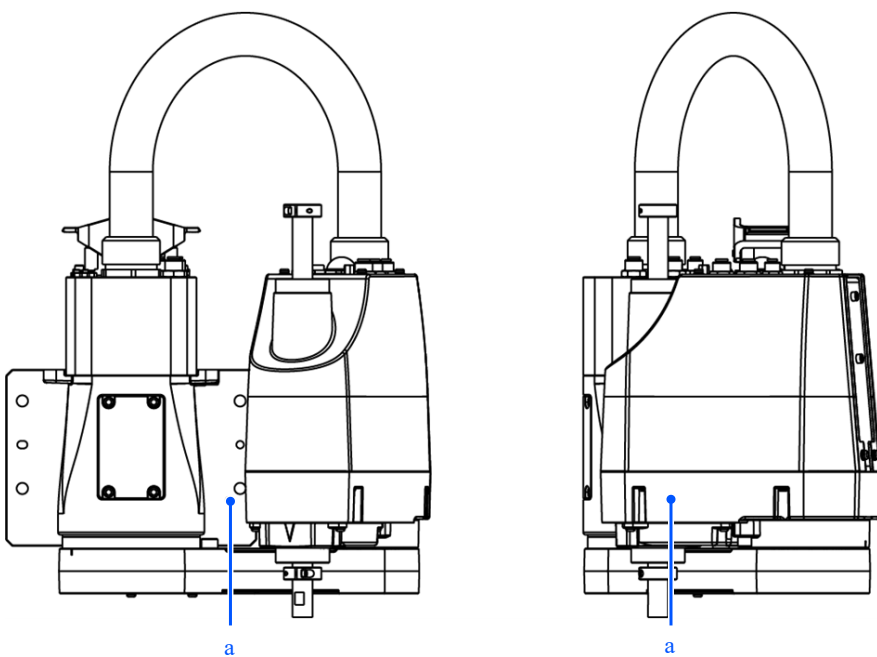

Symbol	Description
a	Center of gravity

2.4 Setting the Hand

2.4.1 Installing the Hand

The hand (end effector) must be prepared by the customer. When installing the hand, take note of the following. For details on attaching the hand, refer to the following manual.

"Hand Function Manual"

WARNING

- Before attaching a hand or peripheral equipment, be sure to always turn off the Controller and related equipment and unplug the power cables. Performing any work procedure with the power turned on is extremely dangerous and may result in electric shock and/or malfunction of the robot system.

CAUTION

When the hand is equipped with a workpiece gripping mechanism, ensure that the wiring and pneumatic tubes do not cause the hand to release the workpiece when the power is turned off. When the wiring and pneumatic tubes are not designed for the hand to maintain its grip on the workpiece when the power is turned off, pressing the emergency stop switch releases the workpiece, which may damage the robot system and the workpiece.

By default, all I/Os are designed to automatically turn off (0) when the power is shut off, when an emergency stop is triggered, or by the robot system's safety function.

However, I/Os set with the Hand function does not turn off (0) when executing the Reset statement, or when performing an emergency stop.

For the risk of the residual air pressure, conduct a risk assessment on the equipment and take the necessary protective measures.

Shaft

- Attach the hand to the lower end of the shaft.
For the layout dimensions in the area around the shaft and the overall dimensions of the Manipulator, refer to the following section.
[Names of Parts and Their Dimensions](#)
- Do not move the upper limit mechanical stop on the lower side of the shaft. When performing a Jump operation, the upper limit mechanical stop may come into contact with the Manipulator body, which may cause the Manipulator to stop functioning properly.
- When attaching the hand to the shaft, have the hand hold the shaft using M4 or larger screws.

Brake release switch

- Joint #3 and Joint #4 have an electromagnetic brake that is triggered when the power is off, preventing them from being moved up and down or rotated by hand.
To move Joint #3 up or down or rotate Joint #4 when attaching a hand, turn on the Controller, and then press the brake release switch.
This button switch is a momentary brake release type where the brake is released only while the button switch is being pressed. The switch releases the brake of Joints #3 and #4 simultaneously.

- When pressing the brake release switch, watch for the shaft descending or rotating under the weight of the hand.
*: The shaft may drop due to the weight of the hand or other object.

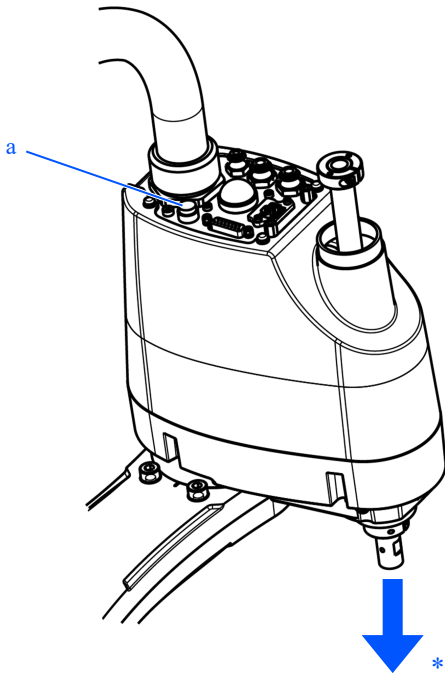

Symbol	Description
a	Brake release switch

Layout

- When attaching and operating a hand, the hand may come into contact with the Manipulator body due to the outer diameter of the hand, the size of the workpiece, or the position of the arm. Carefully consider the interference area of the hand when designing the system layout.

2.4.2 Attaching Cameras and Valves

Arm #2 (top surface and bottom surface) and the cable duct (cover) have threaded holes as shown in the figure below. Use the threaded holes in Arm #2 (bottom surface) for attaching cameras, valves, and other heavy objects to the Manipulator. When attaching pneumatic tubes, Ethernet cables, and other objects to the threaded holes in Arm #2 (top surface) and the cable duct (cover), do not exceed the allowable load.

- Allowable load: 200 g (Assuming a distance of 100 mm from the mounting surface to the center of gravity)

Arm #2 side (GX4 series models)

(Units: mm)

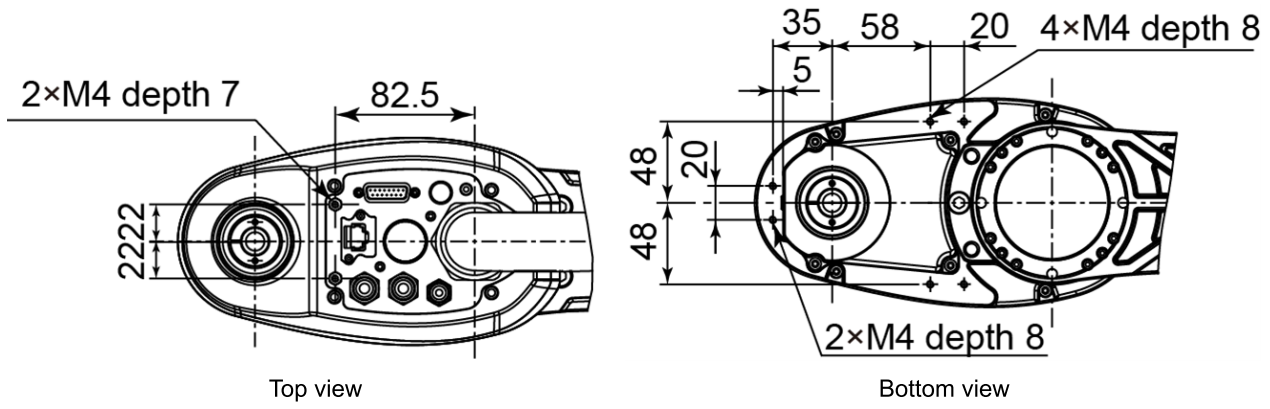

Table top mounting specifications

(Units: mm)

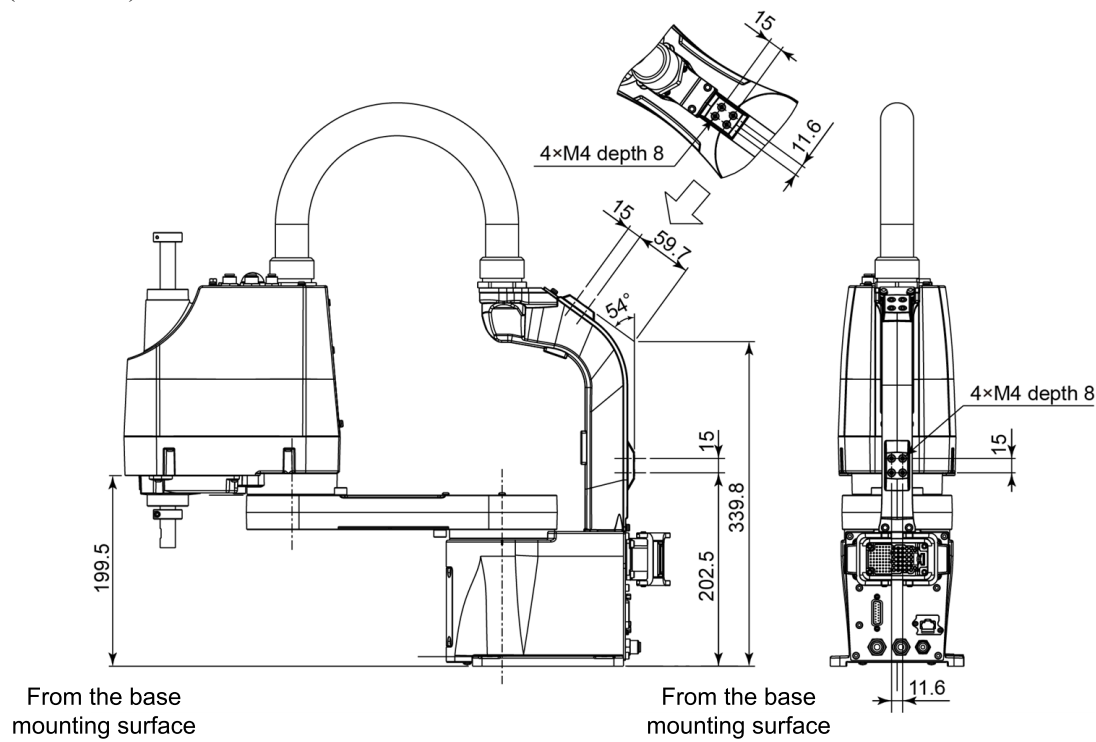
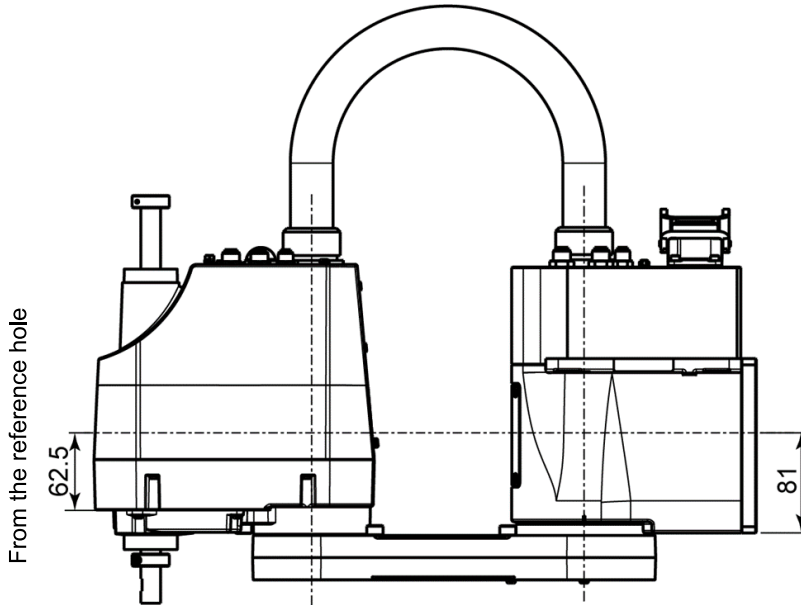

Illustration: GX4-A251S

Multiple mounting specifications

(Units: mm)



KEY POINTS

The maximum tightening torque for the screws mounted to the cable duct cover should be 1.5 N·m.

2.4.3 Weight and Inertia Settings

To ensure that the Manipulator is functioning properly, keep the load (the sum of the weights of the hand and workpiece) and the moment of inertia of the load within the rated values, and do not allow for eccentricity from the center of the Joint #4. If, for some unavoidable reason, the load or moment of inertia exceeds the rated value, or if eccentricity occurs, configure parameters as described in the "Weight setting" and "Inertia setting."

These settings optimize the Manipulator's PTP motion, reduce vibration, and shorten operation times. This also works to curb any persistent vibration that may occur when the hand and workpiece have a large moment of inertia.

You can also perform settings using the "Weight, Inertia, and Eccentricity/offset Measurement Utility".

For details, refer to the following manual:

"Epson RC+ User's Guide - Weight, Inertia, and Eccentricity/offset Measurement Utility"

2.4.3.1 Weight Setting

CAUTION

- The total weight of the hand and the workpiece must not exceed 4 kg. The GX4 series Manipulators are not designed to work with loads exceeding 4 kg. Always set the value according to the load. Setting the hand weight parameter to a value smaller than the actual weight may cause errors or impact that not only impair full functionality but also shorten the life of the mechanical components.

The allowable load weight (hand and workpiece) in the GX4 series is 2 kg at the default rating and 4 kg at the maximum. Depending on the load weight, change the setting for the hand weight parameter in the Weight statement. After the setting is changed, the maximum speed and acceleration/deceleration of the Manipulator during PTP motion that correspond to the "Hand Weight" are corrected automatically.

2.4.3.1.1 Weight of Load Attached to Shaft

The weight of the load (hand + workpiece) attached to the shaft can be set by the "Hand Weight" parameter in the Weight statement.

Epson
RC+

Go to [Tools] - [Robot Manager] - [Weight] panel, and enter the value in the [Weight] text box. (This can also be set using the Weight statement in [Command Window].)

2.4.3.1.2 Weight of Load Attached to Arm

When a camera, valve, or other object is attached to the arm, its weight is converted to the equivalent weight of the shaft and added to the weight of the load attached to shaft to set the "Hand Weight" parameter.

Equivalent weight formula

$$W_M = M \times (L_M + L_1)^2 / (L_1 + L_2)^2$$

W_M : Equivalent weight

M: Weight of load attached to the arm

L_1 : Length of Arm #1

L_2 : Length of Arm #2

L_M : Distance from rotation center of Joint #2 to center of gravity of load attached to the arm

Example:

Calculates [Weight] parameter when a 1 kg camera is attached to the end of GX4 Arm #2 (180 mm from the center of rotation of Joint #2) with a load weight of $W = 1$ kg.

$$W = 1$$

$$M = 1$$

$$L_1 = 220$$

$$L_2 = 130$$

$$L_M = 180$$

$$W_M = 1 \times (180 + 220)^2 / (130 + 220)^2 = 1.31 \text{ (Round up to two decimal places)}$$

$$W + W_M = 1 + 1.31 = 2.31$$

Enter "2.31" for the [Hand Weight] parameter.

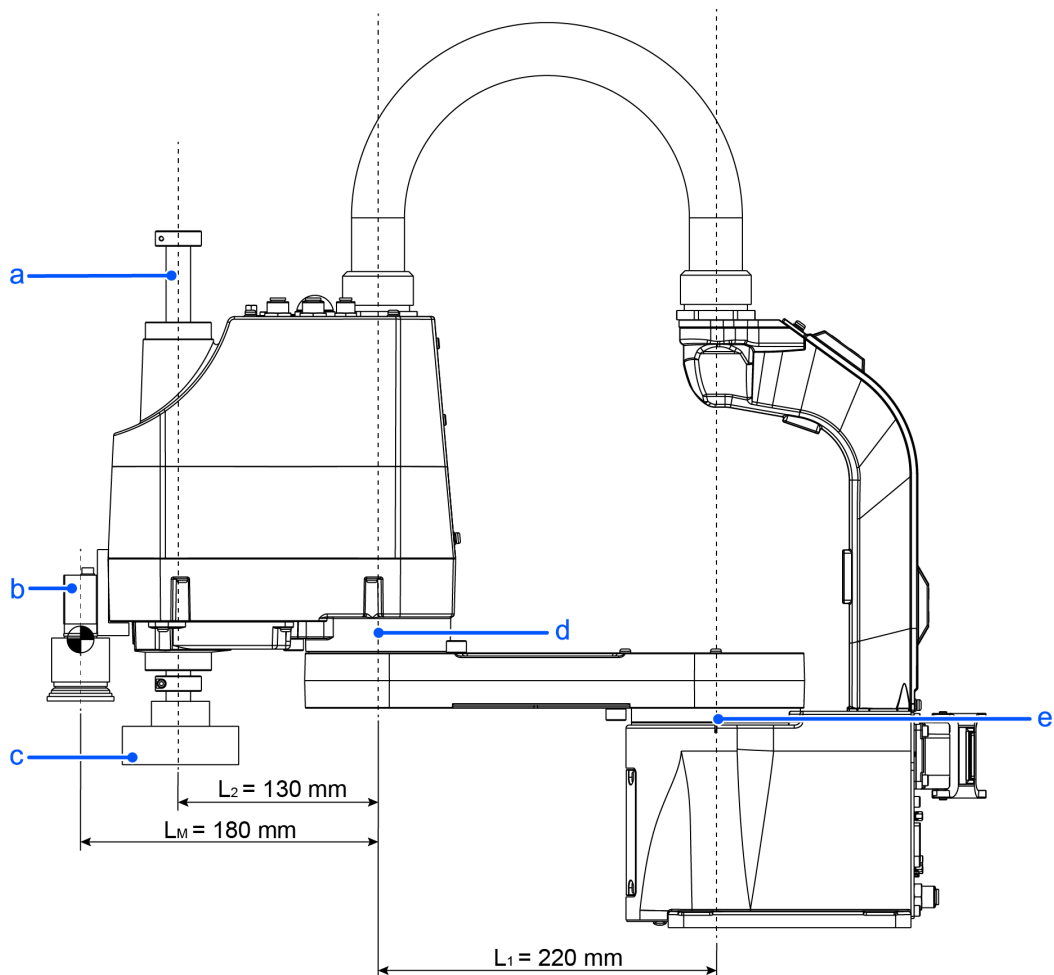

Symbol	Description
a	Shaft
b	Weight of the entire camera M = 1 kg
c	W = 1 kg
d	Joint #2
e	Joint #1

2.4.3.1.3 Automatic Speed Correction at Weight Setting

Standard mode

GX4-A/GX4-B/GX4-C25**, GX4-A/GX4-B/GX4-C30**, GX4-A/GX4-B/GX4-C35**

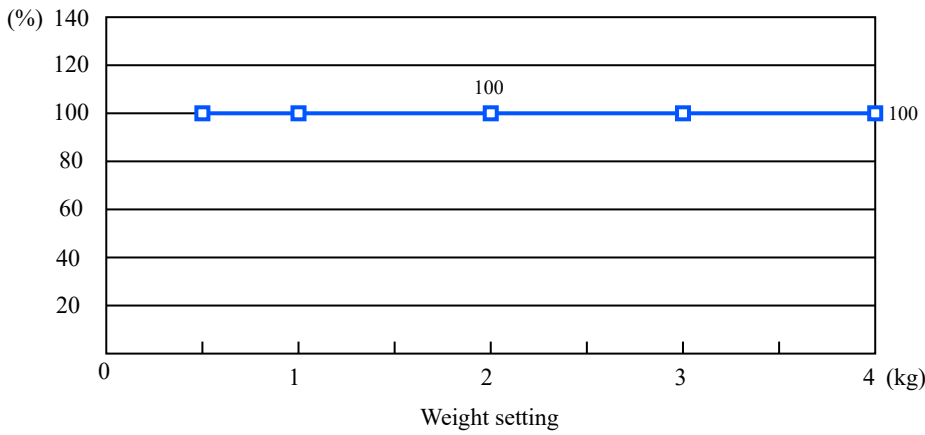

The percentages on the graph are ratios based on 100% as the speed at the rated (2 kg) setting.

Boost mode

GX4-A/GX4-B/GX4-C25**, GX4-A/GX4-B/GX4-C30**, GX4-A/GX4-B/GX4-C35**

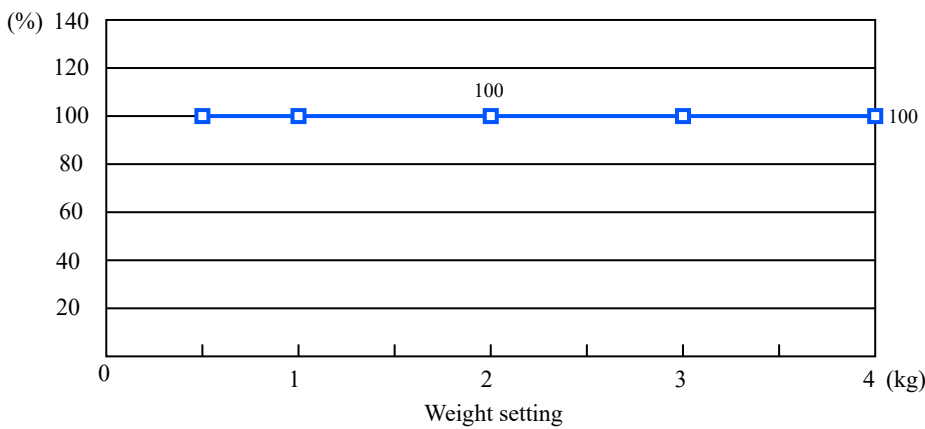

The percentages on the graph are ratios based on 100% as the speed at the rated (2 kg) setting.

2.4.3.1.4 Automatic Acceleration/Deceleration Correction at Weight Setting

Standard mode

GX4-A/GX4-B/GX4-C25**

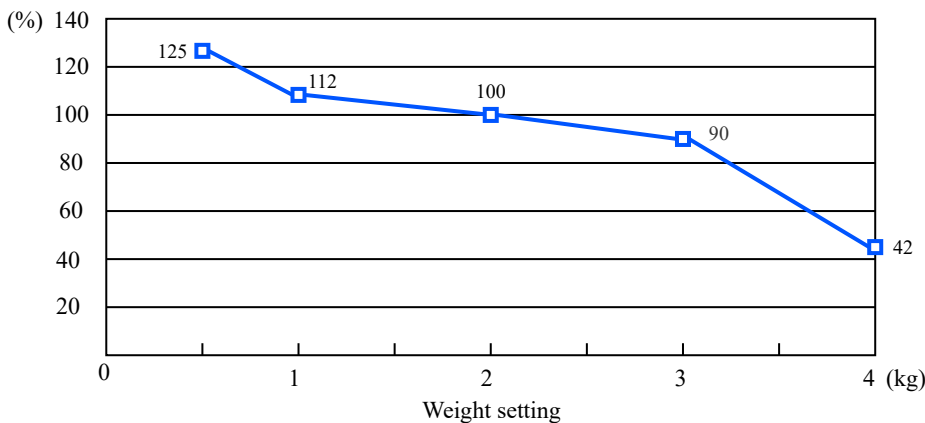

The percentages on the graph are ratios based on 100% as the acceleration/deceleration at the rated (2 kg) setting.

GX4-A/GX4-B/GX4-C30**

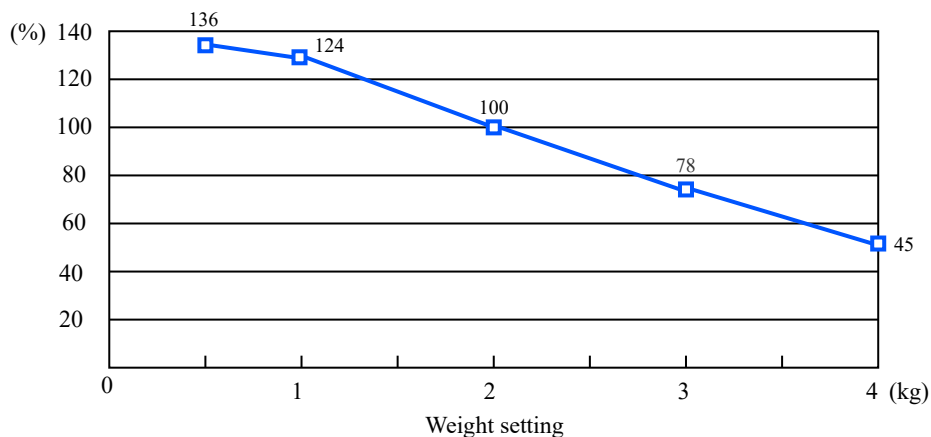

The percentages on the graph are ratios based on 100% as the acceleration/deceleration at the rated (2 kg) setting.

GX4-A/GX4-B/GX4-C35**

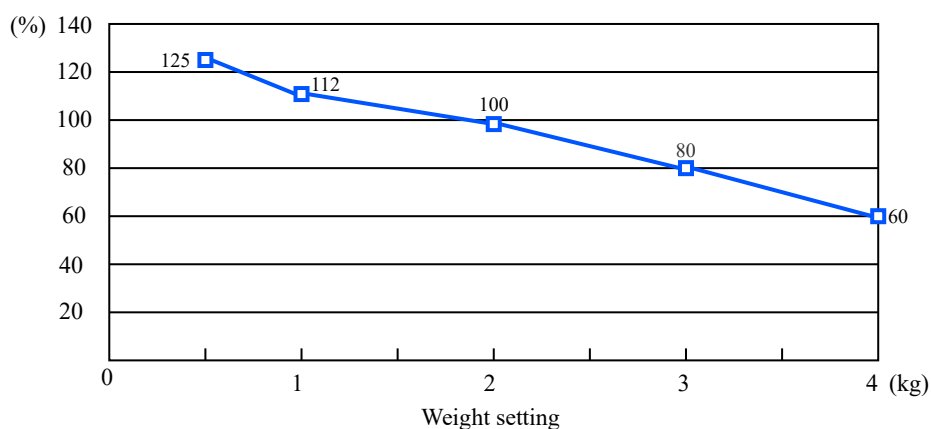

The percentages on the graph are ratios based on 100% as the acceleration/deceleration at the rated (2 kg) setting.

Boost mode

GX4-A/GX4-B/GX4-C25**

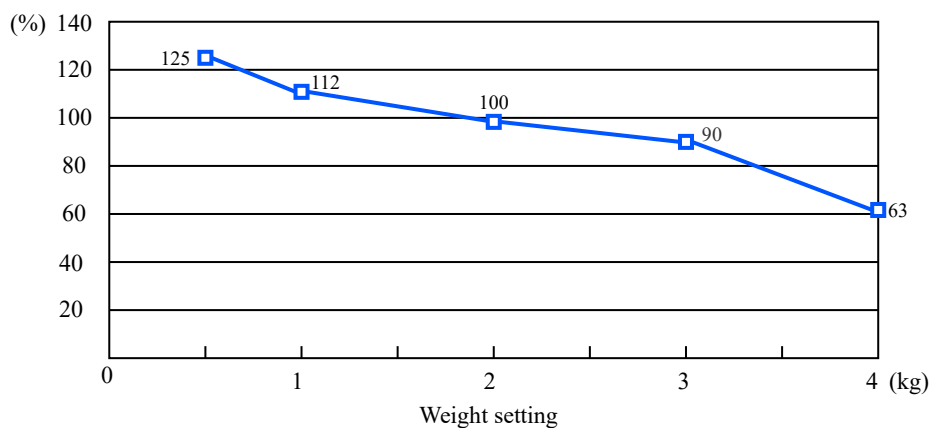

The percentages on the graph are ratios based on 100% as the acceleration/deceleration at the rated (2 kg) setting.

GX4-A/GX4-B/GX4-C30**

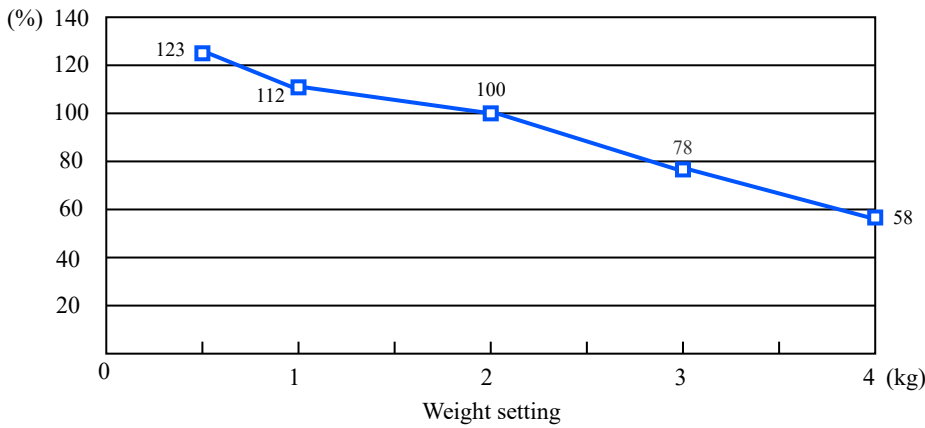

The percentages on the graph are ratios based on 100% as the acceleration/deceleration at the rated (2 kg) setting.

GX4-A/GX4-B/GX4-C35**

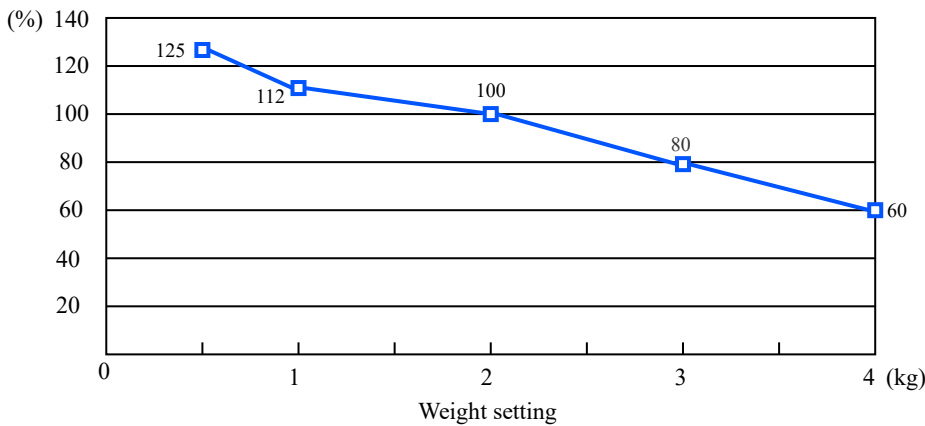

The percentages on the graph are ratios based on 100% as the acceleration/deceleration at the rated (2 kg) setting.

2.4.3.2 Inertia Setting

2.4.3.2.1 Moment of Inertia and Inertia Setting

The moment of inertia is a quantity that expresses how hard it is for an object to turn, and it is expressed in terms of values for the moment of inertia, inertia, or GD^2 . When a hand or other object is attached to a shaft for operation, the moment of inertia of the load must be taken into consideration.

⚠ CAUTION

- The moment of inertia of the load (weight of the hand and workpiece) must be $0.05 \text{ kg}\cdot\text{m}^2$ or less. The GX4 series Manipulators are not designed to work with a moment of inertia exceeding $0.05 \text{ kg}\cdot\text{m}^2$. Always set the value corresponding to the moment of inertia. Setting a parameter value that is smaller than the actual moment of inertia may cause errors or impact, may prevent the Manipulator from working at full functionality, and may shorten the lifespan of mechanical parts.

The allowable moment of inertia of a load for GX4 series Manipulators is $0.005 \text{ kg}\cdot\text{m}^2$ at the default rating and $0.05 \text{ kg}\cdot\text{m}^2$ at the maximum. Depending on the moment of inertia, change the setting of the moment of inertia parameter for the load in the Inertia statement. After the setting is changed, the maximum acceleration/deceleration of Joint #4 during PTP motion that corresponds to the "Inertia" value is corrected automatically.

2.4.3.2.2 Moment of Inertia of Load Attached to Shaft

The moment of inertia of the load (hand + workpiece) attached to the shaft can be set by the "Inertia" parameter in the Inertia statement.

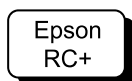

Go to [Tools] - [Robot Manager] - [Inertia] panel, and enter the value in [Inertia]. (This can also be set using the Inertia statement in [Command Window].)

2.4.3.2.3 Automatic Acceleration/Deceleration Correction of Joint #4 at Inertia (Moment of Inertia) Setting

Standard mode

GX4-A/GX4-B/GX4-C25**, GX4-A/GX4-B/GX4-C30**, GX4-A/GX4-B/GX4-C35**

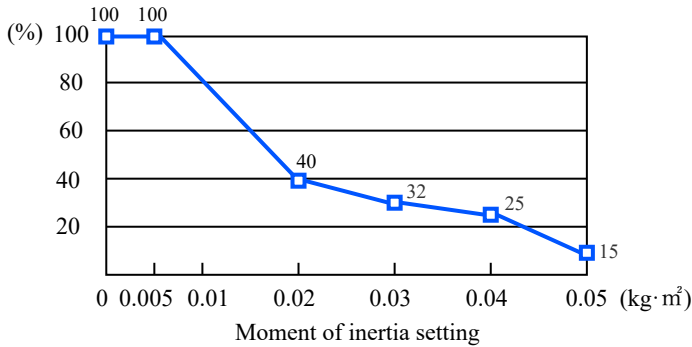

The percentages on the graph are ratios based on 100% as the acceleration/deceleration at the rated (0.005 kg·m²) setting.

Boost mode

GX4-A/GX4-B/GX4-C25**, GX4-A/GX4-B/GX4-C30**, GX4-A/GX4-B/GX4-C35**

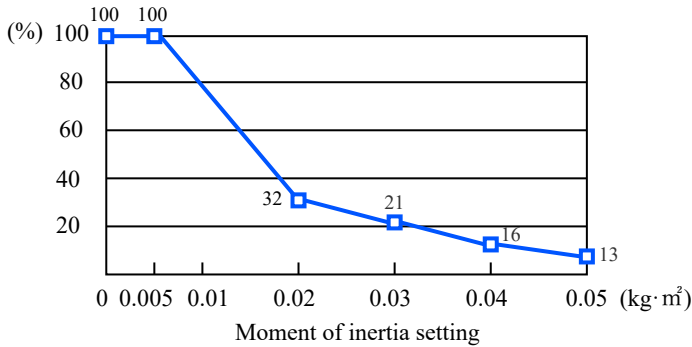

The percentages on the graph are ratios based on 100% as the acceleration/deceleration at the rated (0.005 kg·m²) setting.

2.4.3.2.4 Eccentricity and Inertia Setting

⚠ CAUTION

- The eccentricity of the load (hand and workpiece) must be 150 mm or less.

The GX4 series Manipulators are not designed to work with eccentricities exceeding 150 mm. Always set the value based on the eccentricity. Setting the eccentricity parameter to a value smaller than the actual eccentricity may cause errors or impact that not only impair full functionality but also shorten the life of the mechanical components.

The allowable eccentricity of load for GX4 series Manipulators is 0 mm at the default rating and 150 mm at the maximum. Depending on the load eccentricity, change the setting for the eccentricity parameter in Inertia statement. After the setting is changed, the maximum acceleration/deceleration of the Manipulator during PTP motion that corresponds to the "Eccentricity" is corrected automatically.

Eccentricity

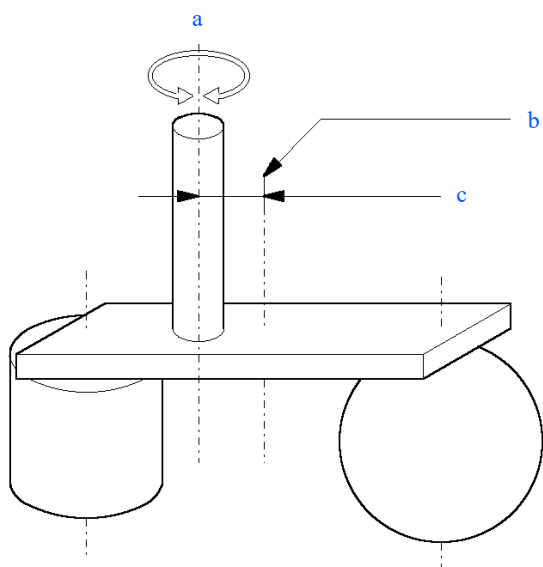

Symbol	Description
a	Rotation axis
b	Load center of gravity position
c	Eccentricity (150 mm or less)

2.4.3.2.5 Eccentricity of Load Attached to Shaft

The eccentricity of the load (hand + workpiece) attached to the shaft can be set by the "Eccentricity" parameter in the Inertia statement.

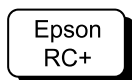

Go to [Tools] - [Robot Manager] - [Inertia] panel, and enter the value in [Eccentricity]. (This can also be set using the Inertia statement in [Command Window].)

2.4.3.2.6 Automatic Acceleration/Deceleration Correction at Inertia (Eccentricity) Setting

Standard mode, boost mode

GX4-A/GX4-B/GX4-C25**, GX4-A/GX4-B/GX4-C30**, GX4-A/GX4-B/GX4-C35**

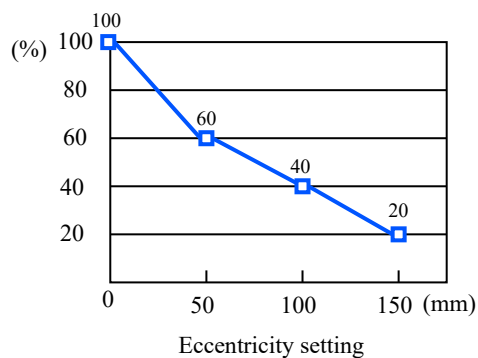

The percentages on the graph are ratios based on 100% as the acceleration/deceleration at the 0 mm setting.

2.4.3.2.7 Calculating the Moment of Inertia

An example of calculating the moment of inertia of a load (hand holding a workpiece) is shown below.

The moment of inertia of the entire load is calculated by the sum of individual parts (a), (b), and (c).

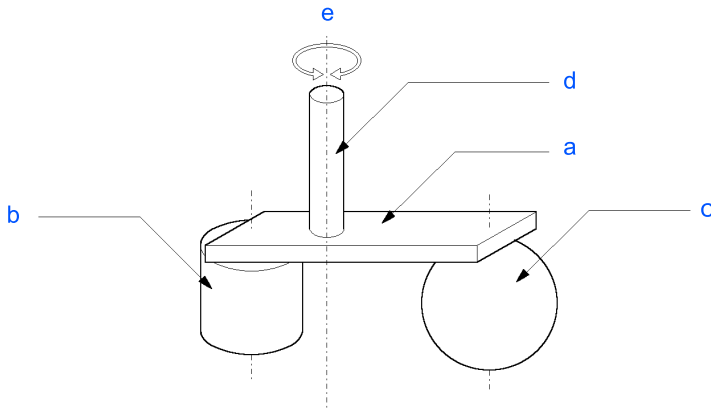

Whole moment of inertia	=	Moment of inertia of end effector (a)	+	Moment of inertia of work piece (b)	+	Moment of inertia of work piece (c)
-------------------------	---	---------------------------------------	---	-------------------------------------	---	-------------------------------------

Symbol	Description
a	Hand
b	Workpiece
c	Workpiece
d	Shaft
e	Rotation axis

The methods for calculating the moment of inertia for (a), (b), and (c) are shown below. Use the moment of inertia of these basic shapes as a reference to find the moment of inertia of the entire load.

(a) Moment of inertia of a rectangular parallelepiped

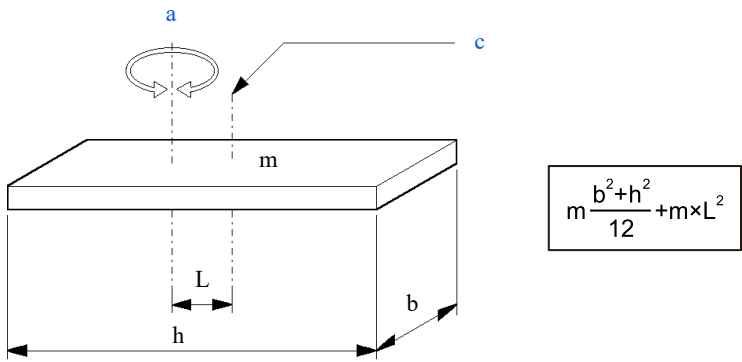

Symbol	Description
a	Rotation axis
c	Center of gravity of rectangular parallelepiped

(b) Moment of inertia of a cylinder

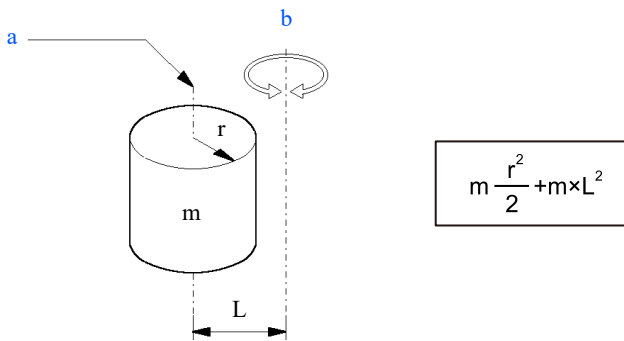

Symbol	Description
a	Center of gravity of cylinder
b	Rotation axis

(c) Moment of inertia of a sphere

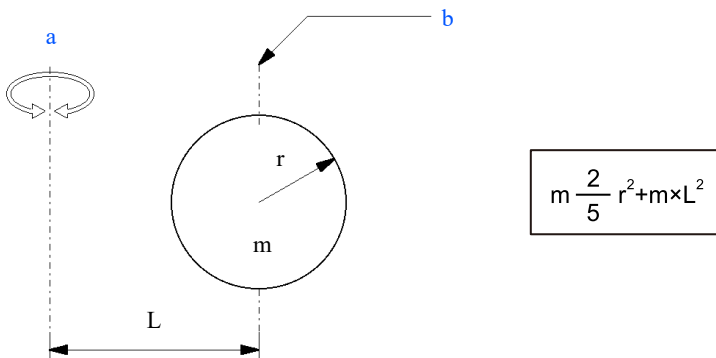

Symbol	Description
a	Rotation axis
b	Center of gravity of sphere

2.4.4 Safety Information for Auto Acceleration of Joint #3

When performing horizontal movement in PTP motion, the operation time can be shorted by setting the shaft to a high position.

When performing horizontal movement in PTP motion, if the shaft height is less than a certain value, the auto acceleration function is activated, and the acceleration/deceleration of the movement is set slower for lower shaft heights. A higher shaft position results in a faster acceleration/deceleration for the movement, but the up movement time and down movement time of the shaft are also required.

Adjust the shaft height by taking into consideration the positional relationship between the current position and the target position.

The shaft height at the time of horizontal movement for the Jump statement can be set by the LimZ statement.

2.4.4.1 Automatic Acceleration/Deceleration Correction by Shaft Position

Standard mode

GX4-A/GX4-B/GX4-C25**

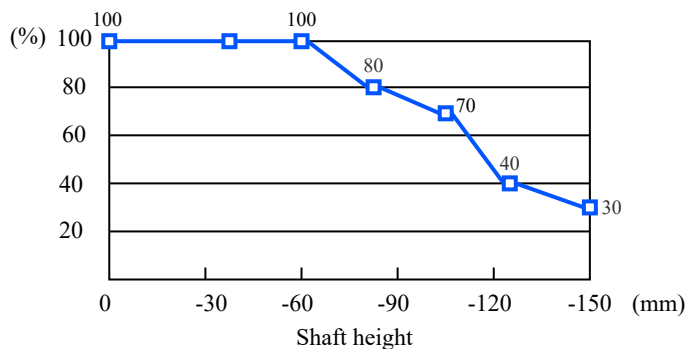

The percentages on the graph are ratios based on 100% as the acceleration/deceleration at the shaft upper limit position.

GX4-A/GX4-B/GX4-C30**

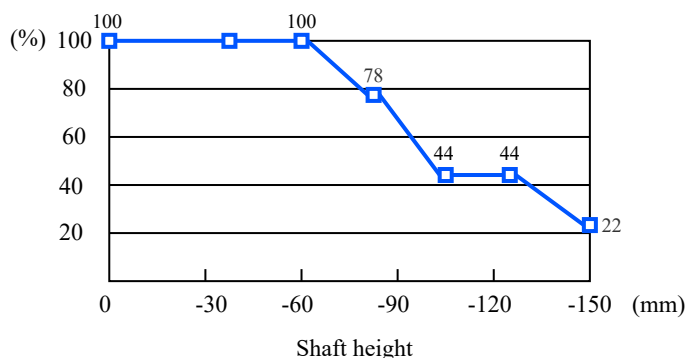

The percentages on the graph are ratios based on 100% as the acceleration/deceleration at the shaft upper limit position.

GX4-A/GX4-B/GX4-C35**

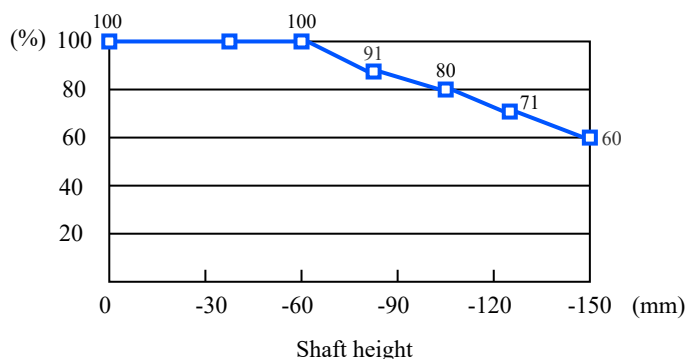

The percentages on the graph are ratios based on 100% as the acceleration/deceleration at the shaft upper limit position.

Boost mode

GX4-A/GX4-B/GX4-C25**, GX4-A/GX4-B/GX4-C30**, GX4-A/GX4-B/GX4-C35**

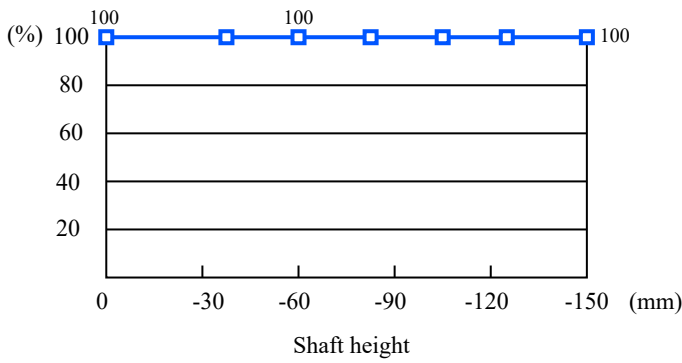

The percentages on the graph are ratios based on 100% as the acceleration/deceleration at the shaft upper limit position.

KEY POINTS

Horizontal movement with the shaft lowered may cause overshooting during positioning.

2.5 Work Envelope

WARNING

- Do not operate the Manipulator with the mechanical stop removed. Removing the mechanical stop is extremely dangerous because the Manipulator may move to a position outside its normal work envelope.

CAUTION

- When restricting the work envelope for safety reasons, be sure to make settings using both the pulse range and mechanical stop.

The work envelope is preset at the factory as explained in the following section.

Standard Work Envelope

The work envelope can be set by one of the following three methods.

- Setting by pulse range (for all joints)
- Setting by mechanical stops (for Joints #1 to #3)
- Setting the rectangular range in the XY coordinate system of the Manipulator (for Joints #1 and #2)

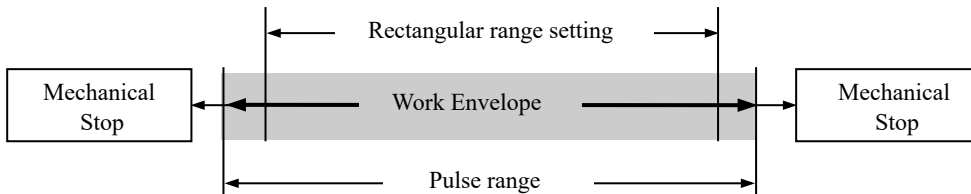

To limit the work envelope for layout efficiency or safety reasons, make the settings as explained in the following sections.

Work Envelope Setting by Pulse Range

Setting the Work Envelope by Mechanical Stops

Setting the Rectangular Range in the XY Coordinate System of the Manipulator

2.5.1 Work Envelope Setting by Pulse Range

Pulses are the basic unit of Manipulator motion. The motion range (work envelope) of the Manipulator is set by the pulse lower limit value and pulse upper limit value (pulse range) for each joint.

Pulse values are read from the encoder output of the servomotor.

For the maximum pulse range, refer to the following sections.

The pulse range must be set inside the mechanical stop settings.

- Joint #1 Maximum Pulse Range
- Joint #2 Maximum Pulse Range
- Joint #3 Maximum Pulse Range
- Joint #4 Maximum Pulse Range

KEY POINTS

Once the Manipulator receives a motion command, it checks whether the target position specified by the command is within the pulse range before operating. If the target position is outside of the pulse range that was set, an error occurs and the Manipulator does not move.

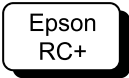

Go to [Tools] - [Robot Manager] - [Range] panel, and make the setting.

This can also be set using the Range statement in [Command Window].

2.5.1.1 Joint #1 Maximum Pulse Range

The 0 (zero) pulse position of Joint #1 is the position where Arm #1 is facing the positive (+) direction on the X-coordinate axis.

With the 0 pulse as a starting point, the counterclockwise pulse value is defined as positive (+), and the clockwise pulse value is defined as negative (-).

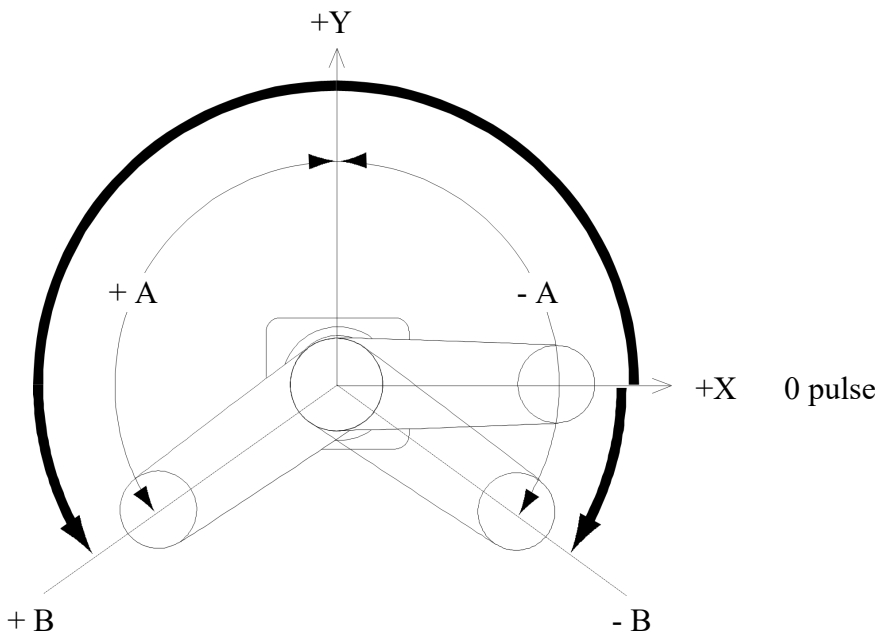

Table top mounting specifications

	Arm Length (mm)	Arm Shape		
		Straight	Left-curved	Right-curved
A: Max. motion range (deg.)	250	±140	-	-
	300		-	-
	350		-165/110	-110/165
B: Max. pulse range (pulse)	250	-1456356 to 6699236	-	-
	300		-	-
	350		2184534 to 5825423	582543 to 7427414

Multiple mounting specifications

	Arm Length (mm)	Arm Shape
		Straight
A: Max. motion range (deg.)	300	±115
	350	±115
B: Max. pulse range (pulse)	300	-728178 to 5971058
	350	-873814 to 6116694

2.5.1.2 Joint #2 Maximum Pulse Range

The 0 (zero) pulse position of Joint #2 is the position where Arm #2 is aligned with Arm #1. (The orientation of Arm #1 does not matter.) With the 0 pulse as a starting point, the counterclockwise pulse value is defined as positive (+), and the clockwise pulse value is defined as negative (-).

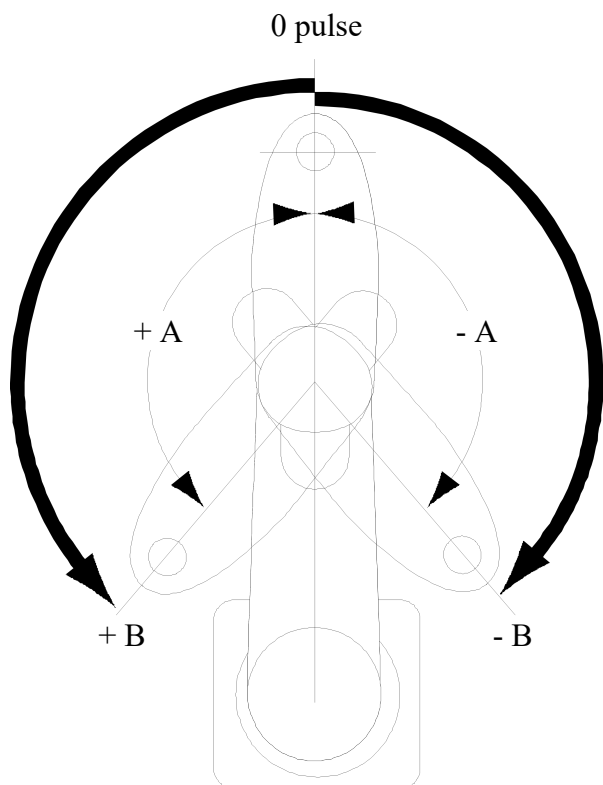

Table top mounting specifications

	Arm Length (mm)	Environmental Specifications	Arm Shape				
			Straight	Left-curved	Right-curved		
A: Max. motion range (deg.)	250	S, E	±141	-	-		
		C	±137				
	300	S, E	±142				
		C	±141				
	350	S, E	±142			-165 to 120	-120 to 165
		C				-160 to 120	-120 to 160
B: Max. pulse range (pulse)	250	S, E	-2566827 to 2566827	-	-		
		C	-2494009 to 2494009				
	300	S, E	-2585032 to 2585032				
		C	-2566827 to 2566827				
	350	S, E	-2585032 to 2585032			-3003734 to 2184534	-2184534 to 3003734
		C				-2912712 to 2184534	-2184534 to 2912712

Multiple mounting specifications

	Arm Length (mm)	Arm Shape
		Straight
A: Max. motion range (deg.)	300	±135
	350	±142
B: Max. pulse range (pulse)	300	-2457600 to 2457600
	350	-2585032 to 2585032

2.5.1.3 Joint #3 Maximum Pulse Range

The 0 (zero) pulse position of Joint #3 is the position where the shaft is at its upper limit. The pulse value is always negative because Joint #3 moves down from the 0 pulse position.

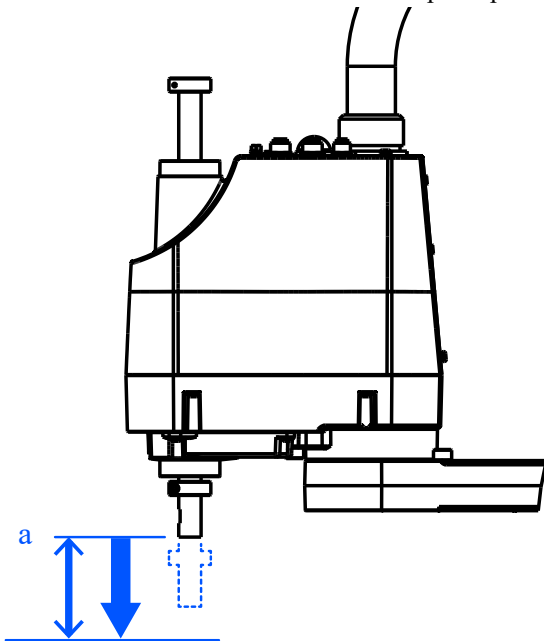

Symbol	Description
a	Upper limit: 0 pulse

	Environmental Specifications	
	S, E	C
Max. motion range(mm)	-150 to 0	-120 to 0
Max. pulse range(pulse)	-1706667 to 0	-1365334 to 0

KEY POINTS

For Manipulators with cleanroom & ESD specifications (GX4-A/GX4-B/GX4-C**1C*), the work envelope set using the Joint #3 mechanical stop cannot be changed.

2.5.1.3.1 Joint #4 Maximum Pulse Range

The 0 (zero) pulse position of Joint #4 is the position where the flat surface near the end of the shaft faces toward the end of Arm #2. (The orientation of Arm #2 does not matter.)

With the 0 pulse as a starting point, the counterclockwise pulse value is defined as positive (+), and the clockwise pulse value is defined as negative (-).

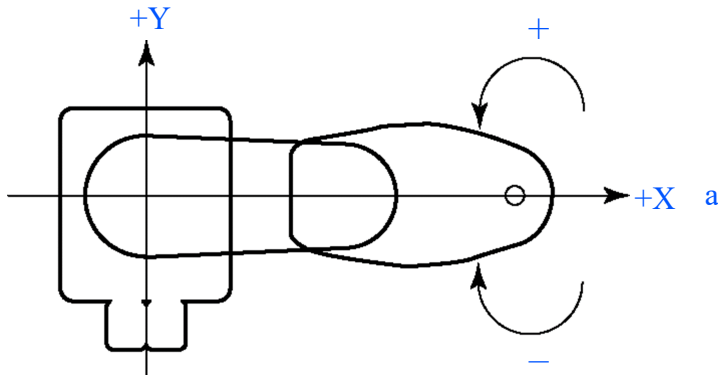

Symbol	Description
a	0 pulse

	All Models
Max. motion range (deg.)	±360
Max. pulse range (pulse)	±1310720

2.5.2 Setting the Work Envelope by Mechanical Stops

Mechanical stops set the absolute work envelope that physically limits where the Manipulator can move. Both Joints #1 and #2 have threaded holes in positions corresponding to angles for the setting area. The positions of the mechanical stops (variable) set the work envelope. Install the bolts in the threaded holes corresponding to the angles to be set. Joint #3 can be set to any length less than the maximum stroke.

Table top mounting specifications

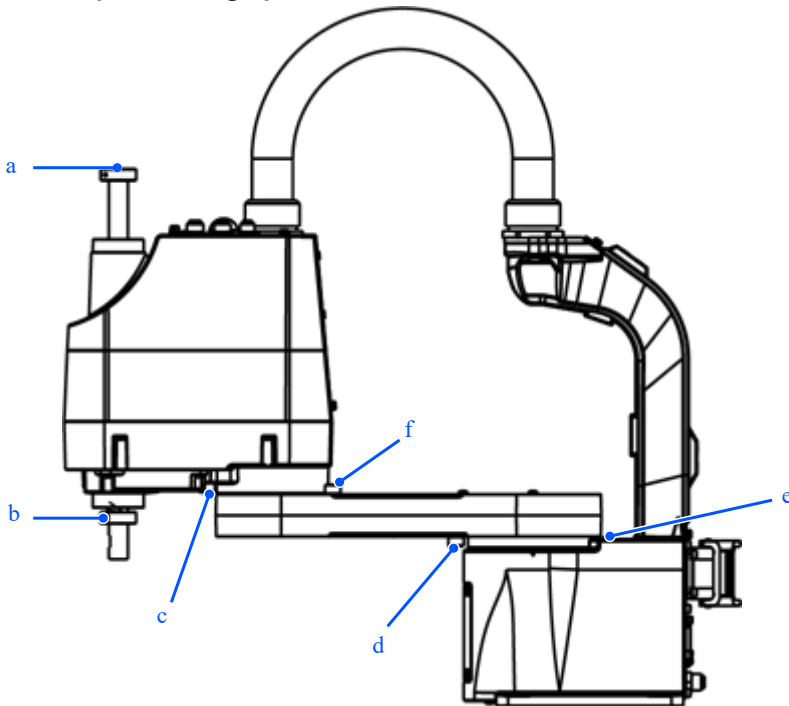

Symbol	Description
a	Joint #3 mechanical stop (lower limit mechanical stop)

Symbol	Description
b	Joint #3 mechanical stop (upper limit mechanical stop) *Do not move the position of the upper limit mechanical stop.
c	Joint #2 mechanical stop (adjustable)
d	Joint #1 mechanical stop (adjustable)
e	Joint #1 mechanical stop (fixed)
f	Joint #2 mechanical stop (fixed)

Multiple mounting specifications

For the model with multiple mounting specifications, only the stop positions that are different from the model with table top mounting specifications are explained here.

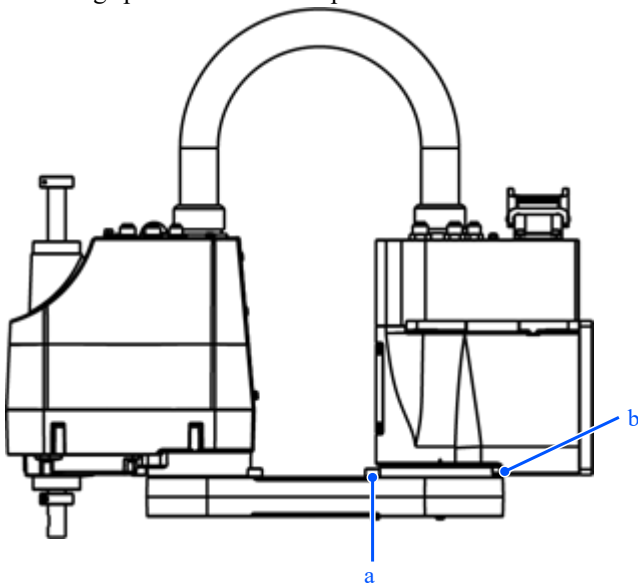

Symbol	Description
a	Joint #1 mechanical stop (adjustable)
b	Joint #1 mechanical stop (fixed)

2.5.2.1 Setting the Mechanical Stops of Joints #1 and #2

Both Joints #1 and #2 have threaded holes in positions corresponding to angles for the setting area. The positions of the mechanical stops (variable) set the work envelope.

Use the following procedure to install the bolts in the threaded holes corresponding to the angles to be set.

1. Turn off the Controller.
2. Install a hexagon socket head cap bolt into the threaded hole corresponding to the setting angle, and tighten it.

Joint #	Hexagon Socket Head Cap Bolt	Number of Bolts	Recommended Tightening Torque	Strength
1, 2	M8 × 10 Total thread	1 for each side	18.0 N·m (194 kgf·cm)	ISO 898-1 property class 10.9 or 12.9 equivalent

3. Turn on the Controller.
4. Set the pulse range corresponding to the new positions of the mechanical stops.

KEY POINTS

Be sure to set the pulse range inside the positions of the mechanical stop range.

Example: Setting Joint #1 to -110° to +110° and Joint #2 to -120° to +120° for the GX4-A1S***

Epson
RC+

Execute the following command in [Command Window].

```
>JRANGE 1,-582542,5825423      'Sets the pulse range of Joint #1
>JRANGE 2,-2184533,2184533    'Sets the pulse range of Joint #2
>RANGE                          'Confirms the setting value using the Range
statement
-582542, 5825423,-2184533,2184533,-1706667
,0, -1310720, 1310720
```

5. Move the arm by hand until it touches the mechanical stops to check that nothing will hinder the arm motion during operation, such as by hitting peripheral equipment.
6. Operate the joint with the new settings at low speeds until it reaches the positions of the minimum and maximum values of the pulse range. Check that the arm does not hit any mechanical stops.
(Check the position of the mechanical stops and the motion range that were set.)

Example: Setting Joint #1 to -110° to +110° and Joint #2 to -120° to +120° for the GX4-A1S***

Epson
RC+

Execute the following command in [Command Window].

```
>MOTOR ON                      'Turns on the motor
>POWER LOW                      'Sets to low power mode
>SPEED 5                        'Sets to low speed
>PULSE -582542,0,0,0           'Moves to the minimum pulse position of Joint #1
>PULSE 5825423,0,0,0          'Moves to the maximum pulse position of Joint #1
>PULSE 2621440,-2184533,0,0    'Moves to the minimum pulse position of Joint #2
>PULSE 2621440,2184533,0,0     'Moves to the maximum pulse position of Joint #2
```

The Pulse statement (Go Pulse statement) moves all joints to the specified positions at the same time. Set safe positions after taking into consideration the motion of the joints whose pulse range have been changed and also the other joints. In this example, when checking Joint #2, Joint #1 is moved to the 0° position (pulse value: 2621440) near the center of its work envelope.

If the arm hits a mechanical stop or if an error occurs after the arm hits a mechanical stop, either reset the pulse range to a narrower pulse range so that nothing blocks the arm motion, or extend the positions of the mechanical stops within the limit.

Joint #1 mechanical stop

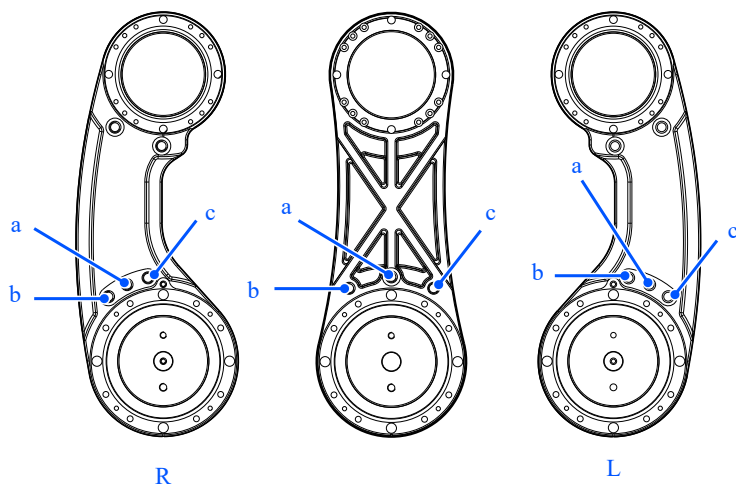

Views from the bottom of Arm #1

	Mounting Specifications	Arm Length (mm)	Arm Shape	Mechanical Stop Position		
				a	b	c
Max. motion range (deg.)	Table top	250	Straight	±140	-110	+110
		300	Straight			
		350	Straight			
			Left-curved	-165 to 110	-150	+95
		Right-curved	-110 to 165	-95	+150	
	Multiple	300	Straight	±115	-102.6	+102.6
Multiple	350	Straight	±120	-103.5	+103.5	
Max. pulse range (pulse)	Table top	250	Straight	-1456356 ~ 6699236	-582542	5825423
		300	Straight			
		350	Straight			
			Left-curved	-2184534 to 5825423	-1747627	5388516
		Right-curved	-582543 to 7427414	-145636	6990507	
	Multiple	300	Straight	-728178 to 5971058	-367002	5609882
		350	Straight	-873814 to 6116694	-393216	5636096

Joint #2 mechanical stop

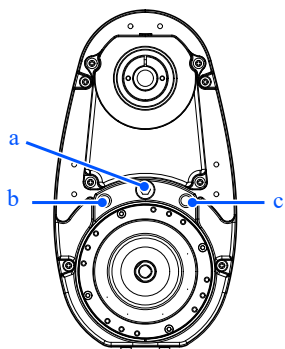

	Mounting Specifications	Arm Length (mm)	Arm Shape	Environmental Specifications	Mechanical Stop Position		
					a	b	c
Max. motion range (deg.)	Table top	250	Straight	S, E	±141	-111	+111
				C	±137	-107	+107
		300	Straight	S, E	±142	-112	+112
				C	±141	-111	+111
		350	Straight	S, E, C	±142	-112	+112
				S, E	-165 to 120	-135	+90
			Left-curved	C	-160 to 120	-130	+90
				S, E	-120 to 165	-90	+135
		Right-curved	C	-120 to 160	-90	+130	
			Multiple	300	Straight	S, E, C	±135
350	Straight	S, C		±142	-112	+112	
Max. pulse range (pulse)	Table top	250	Straight	S, E	-2566827 to 2566827	-2020693	+2020693
				C	-2494009 to 2494009	-1947876	+1947876
		300	Straight	S, E	-2585032 to 2585032	-2038898	+2038898
				C	-2566827 to 2566827	-2020693	+2020693
		350	Straight	S, E, C	-2585032 to 2585032	-2038898	+2038898
				S, E	-3003734 to 2184534	-2457600	+1638400
			Left-curved	C	-2912712 to 2184534	-2366578	+1638400
				S, E	-2184534 to 3003734	-1638400	+2457600
		Right-curved	S, E	-2184534 to 3003734	-1638400	+2457600	

				C	-2184534 to 2912712	-1638400	+2366578
	Multiple	300	Straight	S, E, C	-2457600 to 2457600	-1911467	+1911467
		350	Straight	S, E, C	-2585032 to 2585032	-2038898	+2038898

KEY POINTS

For models with multiple mounting specifications, the work envelope cannot be completely limited because the Manipulator could hit a wall within the setting range of the mechanical stops.

2.5.2.2 Setting the Mechanical Stop of Joint #3

KEY POINTS

This method can be used only for the Manipulator models with standard specifications (GX4-***1S*) and ESD specifications (GX4-***1E*).

For Manipulators with cleanroom & ESD specifications (GX4-***1C*), the work envelope set by the Joint #3 mechanical stop cannot be changed.

1. Turn on the Controller, and turn off the motors using the Motor OFF statement.
2. Push up the shaft while pressing the brake release switch.
Do not push the shaft up to its upper limit or it will be difficult for the arm top cover to be removed. Push the shaft up to a position where the Joint #3 mechanical stop can be changed.

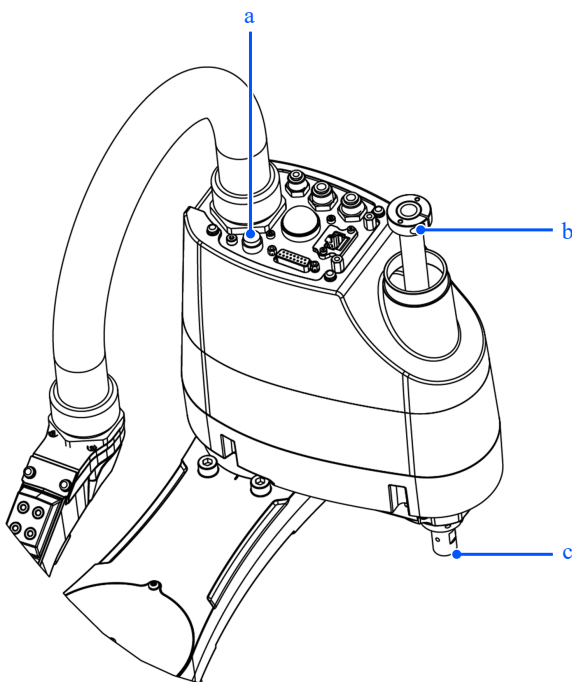

Symbol	Description
a	Brake release switch

Symbol	Description
b	Lower limit mechanical stop mounting screw M3 × 10
c	Shaft

KEY POINTS

When you press the brake release switch, the shaft may lower due to the weight of the hand. Be sure to hold the shaft by hand while pressing the switch.

- Turn off the Controller.
- Loosen the lower limit mechanical stop screw (M3 × 10).

KEY POINTS

A mechanical stop is mounted on both the top and bottom of Joint #3. However, only the position of the lower limit mechanical stop on the top can be changed. Do not remove the upper limit mechanical stop on the bottom because the origin position of Joint #3 is determined by this stop.

- The upper end of the shaft defines the maximum stroke position. Move the lower limit mechanical stop down by the length that you want to limit the stroke.
 For example, when the lower limit mechanical stop is set at the "150 mm" stroke, the lower limit Z coordinate value is "-150". To change this value to "-130", move the lower limit mechanical stop down by 20 mm. Use calipers or similar tool to measure the distance when adjusting the mechanical stop.

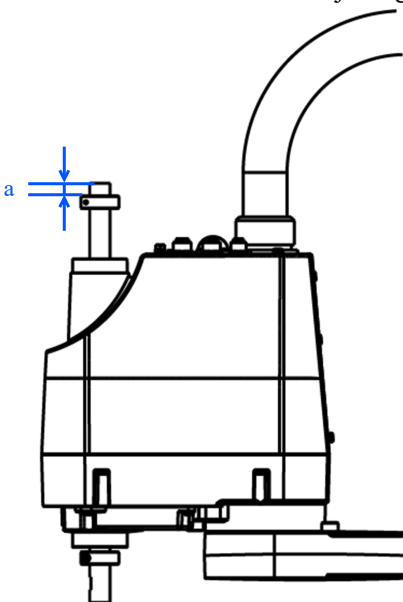

Symbol	Description
a	Measurement length

- Firmly tighten the lower limit mechanical stop screw (M3 × 10) while being careful that it does not enter the shaft groove. Recommended tightening torque: 2.4 N·m (25 kgf·cm)
- Turn on the Controller.

8. Press down Joint #3 while pressing the brake release switch, and then check the lower limit position. Do not lower the mechanical stop too far. Otherwise, the joint may not reach a target position.
9. Calculate the lower limit pulse value of the pulse range using the formula shown below, and set the value.
The result of the calculation is always negative because the lower limit Z coordinate value is negative.
GX4-A/GX4-B/GX4-C1S*(Z:-150 mm): Lower limit of pulse = (lower limit Z coordinate value)/16 × 131072 × (50/36)**

Example: To lower the mechanical stop by 50 mm and change the lower limit Z coordinate value to "-100" with a 150 mm stroke

$$(-100)/16131072 \times (50/36) = -1137778$$

Epson
RC+

Execute the following command in [Command Window].

```
>JRANGE 3,-1137778 ,0      ' Sets the pulse range of Joint #3
```

10. Using the Pulse statement (Go Pulse statement), move Joint #3 to the lower limit position of the pulse range that was set at low speed.
If the mechanical stop range is less than the pulse range, Joint #3 will hit the mechanical stop and an error will occur. When an error occurs, either change the pulse range to a narrower setting or extend the position of the mechanical stop within the limit.

Example: To lower the mechanical stop by 50 mm and change the lower limit Z coordinate value to "-100" with a 150 mm stroke

Epson
RC+

Execute the following command in [Command Window]. Enter the value calculated in Step (9) for -1137778.

```
>MOTOR ON                'Turns on the motor
>SPEED 5                  'Sets to low speed
>PULSE 0,0,-1137778,0    ' Moves to the lower limit pulse position of Joint #3
```

(In this example, all pulses except those for Joint #3 are "0". Substitute these "0" values with the other pulse values to specify a position where interference will not occur even when lowering Joint #3.)

2.5.3 Setting the Rectangular Range in the XY Coordinate System of the Manipulator

(For Joints #1 and #2)

Use this procedure to set the upper and lower limits of the X and Y coordinates.

This setting is a software-based limit only, and so it does not change the maximum physical range. The maximum physical range is based on the position of the mechanical stops.

Epson
RC+

Go to [Tools] - [Robot Manager] - [XYZ Limits] panel, and make the setting. This can also be set using the XYLim statement in [Command Window].

2.5.4 Standard Work Envelope

The following "work envelope" diagrams show the model with standard (maximum) specifications. When each joint motor is under servo control, the center of the Manipulator shaft's lowest point moves in the ranges shown in the figure.

- Range to mechanical stop
This is the range where the center of shaft's lowest point can be moved when each joint motor is not under servo control.
- Mechanical stop
This is the stop that sets the absolute work envelope where the Manipulator cannot move beyond mechanically.
- Maximum zone
This is the range that contains the farthest reach of the arms where interference can occur. If the maximum radius of the hand exceeds 60 mm, add the "Range to mechanical stop" and the "Radius of the hand." The total value is specified as the maximum zone.

Table top mounting specifications: Straight arm

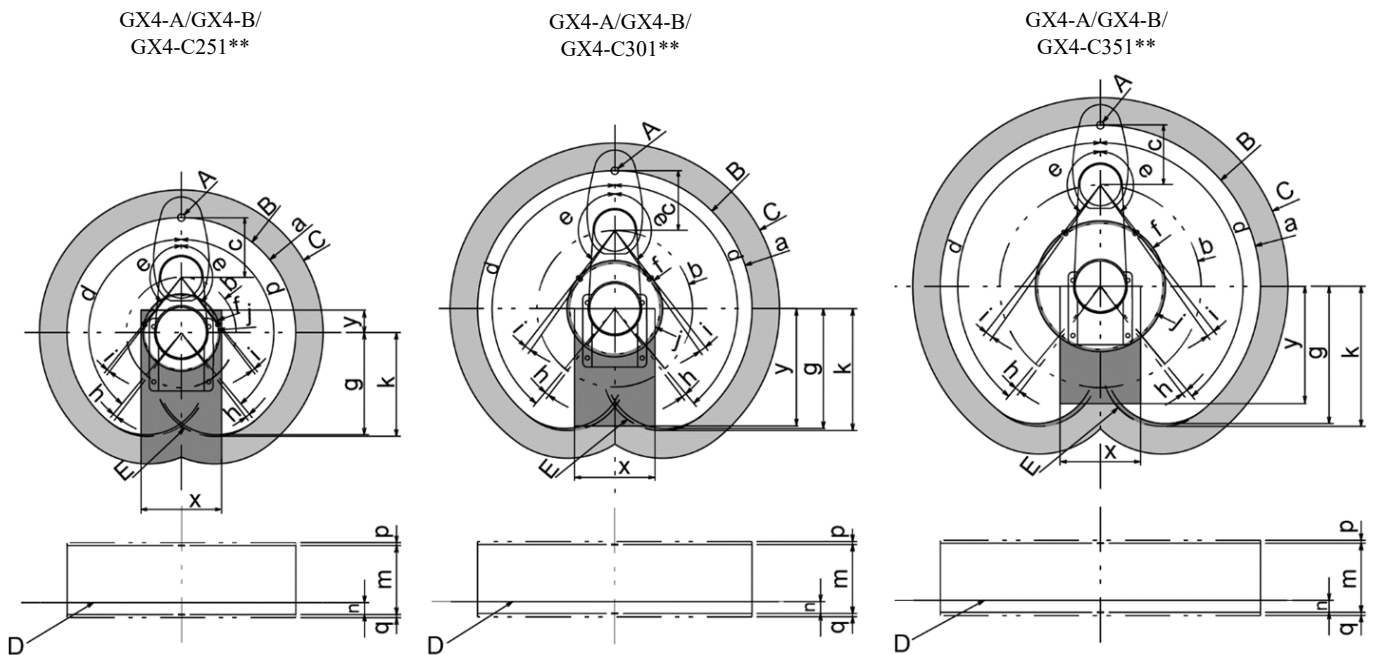

Symbol	Description
A	Center of Joint #3
B	Work envelope
C	Maximum zone
D	Base mounting surface
E	Range to mechanical stop

		GX4-A/GX4-B/GX4-C251* GX4-A/GX4-B/GX4-C251*B		GX4-A/GX4-B/GX4-C301* GX4-A/GX4-B/GX4-C301*B		GX4-A/GX4-B/GX4-C351* GX4-A/GX4-B/GX4-C351*B	
		S, E	C	S, E	C	S, E	C
a	Length of Arm #1 + Arm #2 (mm)	250		300		350	

		GX4-A/GX4-B/GX4-C251* GX4-A/GX4-B/GX4-C251*B		GX4-A/GX4-B/GX4-C301* GX4-A/GX4-B/GX4-C301*B		GX4-A/GX4-B/GX4-C351* GX4-A/GX4-B/GX4-C351*B	
		S, E	C	S, E	C	S, E	C
b	Length of Arm #1 (mm)	120		170		220	
c	Length of Arm #2 (mm)	130					
d	Joint #1 motion (°)	140					
e	Joint #2 motion (°)	141	137	142	141	142	
f	(Work envelope)	87	95	105	107	142	
g	(Work envelope of the back side)	221.9		260.2		298.5	
h	Angle to the Joint #1 mechanical stop (°)	2.5					
i	Angle to the Joint #2 mechanical stop (°)	1.5		2.4	1.6	2.5	
j	(Mechanical stop area)	84	92	99	103	137	
k	(Mechanical stop area of the back side)	225.2		264.9		304.5	
m	Joint #3 motion stroke	150	120	150	120	150	120
n	Distance from base mounting surface	26	30	26	30	26	30
p	Joint #3 mechanical stop area top end	6.5	10.5	6.5	10.5	6.5	10.5
q	Joint #3 mechanical stop area bottom end	6.8	1.3	6.8	1.3	6.8	1.3
x	Dimensions of motion prohibited area (mm)	176					
y	Dimensions of motion prohibited area (mm)	+49 (infinite on back side)	+66 (infinite on back side)	-255			

Multiple mounting specifications: Straight arm

GX4-A/GX4-B/
GX4-C301*M

GX4-A/GX4-B/
GX4-C351*M

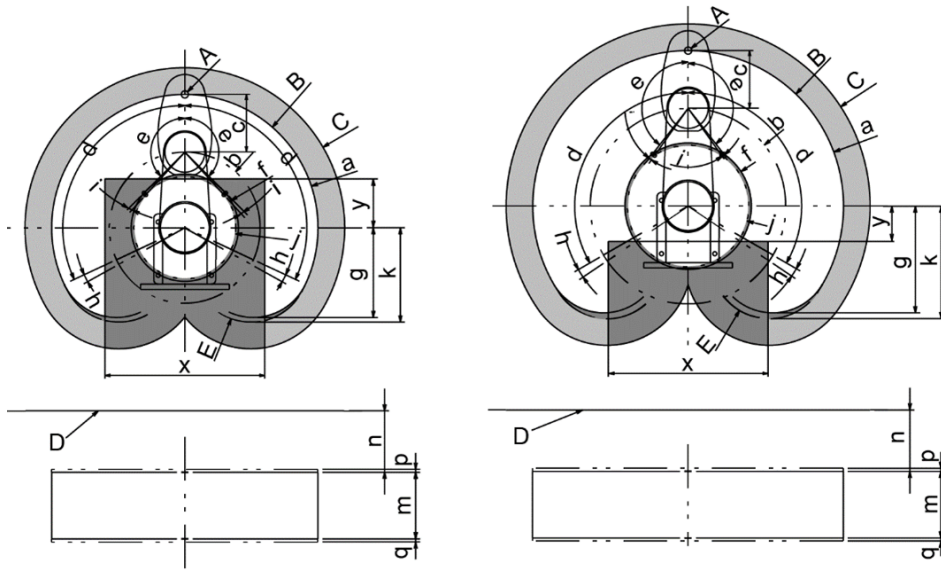

Symbol	Description
A	Center of Joint #3
B	Work envelope
C	Maximum zone
D	Base mounting surface
E	Range to mechanical stop

		GX4-A/GX4-B/GX4-C301*M		GX4-A/GX4-B/GX4-C351*M	
		S, E	C	S, E	C
a	Length of Arm #1 + Arm #2 (mm)	300		350	
b	Length of Arm #1 (mm)	170		220	
c	Length of Arm #2 (mm)	130			
d	Joint #1 motion (°)	115		120	
e	Joint #2 motion (°)	135		142	
f	(Work envelope)	121		142	
g	(Work envelope on the back side)	210.8		240	
h	Angle to the Joint #1 mechanical stop (°)	4.0			
i	Angle to the Joint #2 mechanical stop (°)	2.5			
j	(Mechanical stop area)	115		137	
k	(Mechanical stop area of the back side)	212.4		253	
m	Joint #3 motion stroke	150	120	150	120

		GX4-A/GX4-B/GX4-C301*M		GX4-A/GX4-B/GX4-C351*M	
		S, E	C	S, E	C
n	Distance from base mounting surface	138	172	138	172
p	Joint #3 mechanical stop area top end	6.5	10.5	6.5	10.5
q	Joint #3 mechanical stop area bottom end	6.8	1.3	6.8	1.3
x	Dimensions of motion prohibited area (mm)	360			
y	Dimensions of motion prohibited area (mm)	+110 (infinite on back side)		-79.5 (infinite on back side)	

Table top mounting specifications: Curved arm

GX4-A/GX4-B/
GX4-C351**-L

GX4-A/GX4-B/
GX4-C351**-R

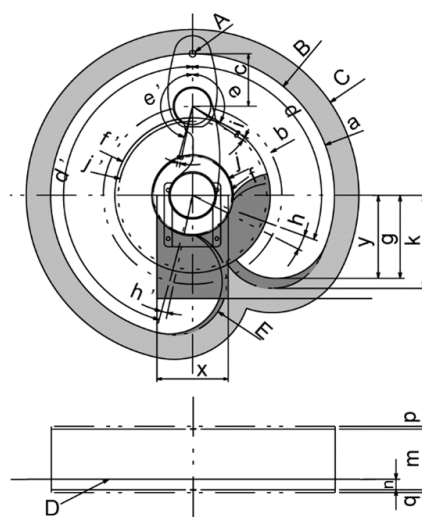
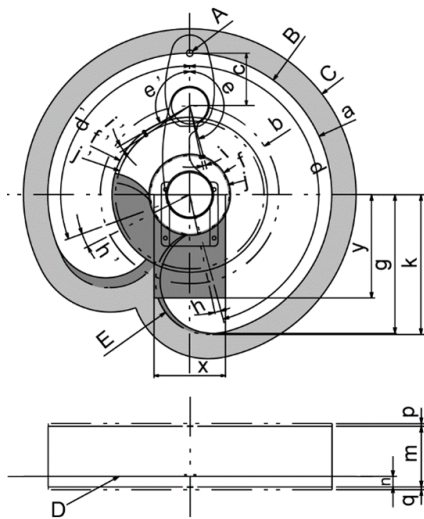

Symbol	Description
A	Center of Joint #3
B	Work envelope
C	Maximum zone
D	Base mounting surface
E	Range to mechanical stop

		GX4-A/GX4-B/GX4-C351*-L GX4-A/GX4-B/GX4-C351*B-L		GX4-A/GX4-B/GX4-C351*-R GX4-A/GX4-B/GX4-C351*B-R	
		L		R	
		S, E	C	S, E	C
a	Length of Arm #1 + Arm #2 (mm)	350			
b	Length of Arm #1 (mm)	220			
c	Length of Arm #2 (mm)	130			

		GX4-A/GX4-B/GX4-C351*-L GX4-A/GX4-B/GX4-C351*B- L		GX4-A/GX4-B/GX4-C351*-R GX4-A/GX4-B/GX4-C351*B- R	
		S, E	C	S, E	C
d / d'	Joint #1 motion (°)	165 / 110		110 / 165	
e / e'	Joint #2 motion (°)	165 / 120	160 / 120	120 / 165	120 / 160
f / f'	(Work envelope)	100 / 192	107 / 192	192 / 100	192 / 107
g	(Work envelope on the back side)	342.5		342.5	
h / h'	Angle of Joint #1 mechanical stop (°)	3.0 / 7.0		7.0 / 3.0	
i / i'	Angle to Joint #2 mechanical stop (°)	2.8 / 3.8	3.5 / 3.8	3.8 / 2.8	3.8 / 3.5
j / j'	(Mechanical stop area)	97 / 183	102 / 183	183 / 97	183 / 102
k	(Mechanical stop area of the back side)	345.2		345.2	
m	Joint #3 motion stroke	150	120	150	120
n	Distance from base mounting surface	26	30	26	30
p	Joint #3 mechanical stop area top end	6.5	10.5	6.5	10.5
q	Joint #3 mechanical stop area bottom end	6.8	1.3	6.8	1.3
x	Dimensions of motion prohibited area (mm)	176			
y	Dimensions of motion prohibited area (mm)	-255			

3. GX8 Manipulator

This chapter contains information on the setup and operation of the Manipulators.
Please read this chapter thoroughly before setting up and operating the Manipulators.

3.1 Safety

The Manipulator and its related equipment should be unpacked and transported by people who have received installation training provided by Epson and the suppliers. Also, the laws and regulations of the installation country must be followed.

Before use, please read this manual and other related manuals to ensure correct use.

After reading this manual, store it in an easily accessible location for future reference.

This product is intended for transporting and assembling parts in a safely isolated area.

3.1.1 Conventions Used in This Manual

The following symbols are used in this manual to indicate important safety information. Be sure to read the descriptions shown with each symbol.

WARNING

This symbol indicates an imminently hazardous situation which, if operation is not performed properly, will result in death or serious injury.

WARNING

This symbol indicates a potentially hazardous situation which, if operation is not performed properly, could result in an injury due to electric shock.

CAUTION

This symbol indicates a potentially hazardous situation which, if operation is not performed properly, may result in a minor or moderate injury or in property damage only.

3.1.2 Design and Installation Safety

The robot system should be designed and installed by people who have received installation training provided by Epson and the suppliers.

Design personnel should refer to the following manuals:

"Safety Manual"

"Controller Manual"

"Manipulator Manual"

Refer to the following section for the installation safety information.

Environment and Installation

Be sure to read this section and follow the safety information before installation to ensure that the installation work is performed safely.

3.1.2.1 Strength of the Ball Screw Spline

If a load exceeding the allowable bending load is applied to the ball screw spline, it may not work properly due to deformation or breakage of the shaft.

If a load exceeding the allowable value is applied to the ball screw spline, the ball screw spline unit must be replaced.

The allowable load varies depending on the distance over which the load is applied. To calculate the allowable load, refer to the formula below.

Allowable bending moment

GX8: $M=27,000 \text{ N}\cdot\text{mm}$

Calculation example: 270 N load applied at 100 mm from the end of the spline nut

Moment

$$M=F\cdot L=100\cdot 270=27,000 \text{ N}\cdot\text{mm}$$

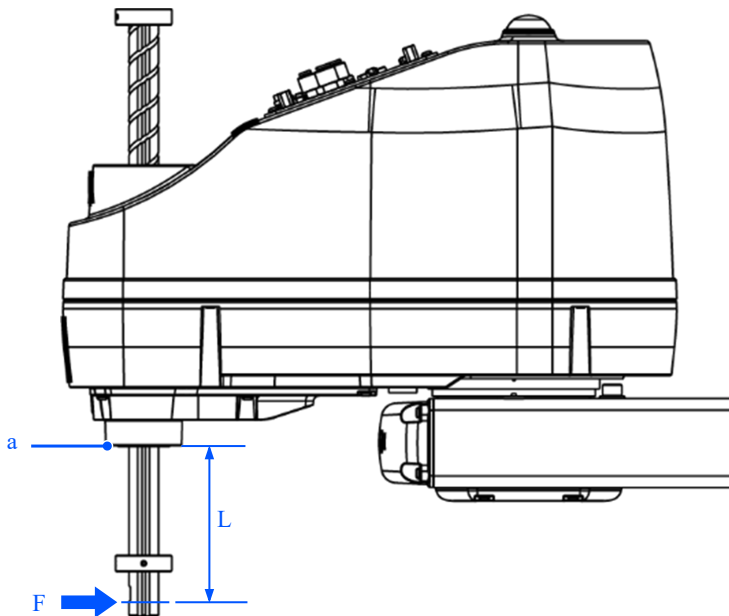

Symbol	Description
a	Spline nut end

3.1.3 Operation Safety

The following items are safety precautions for operating personnel:

WARNING

- Be sure to read the Safety Manual before use. Operating the robot system without understanding the safety information can be extremely dangerous and may result in serious injury or severe equipment damage.
- Before operating the robot system, make sure that no one is inside the safety barriers. The robot system can be operated in the teaching operation mode even when someone is inside the safety barriers. Even though the motion of the Manipulator is always restricted (low speed and low power) to ensure operator safety, an unexpected movement by the Manipulator can be extremely dangerous and may cause serious safety problems.
- If the Manipulator makes any abnormal movements during operation of the robot system, do not hesitate to immediately press the emergency stop switch.

WARNING

- To perform the power supply lockout, remove the power plug. Be sure to connect the AC power cable to a power outlet. Do not connect it directly to a factory power source.
- Before performing any replacement work, inform others in the area that you are working, and then turn off the Controller and related equipment, and unplug the power cable from the power source. Performing any work procedure with the power turned on is extremely dangerous and may result in electric shock and/or malfunction of the robot system.
- Do not connect or disconnect the connector of the M/C cable while the Controller is turned on. There is a risk the Manipulator may malfunction, which is extremely hazardous. Also, performing any work procedure with the power turned on may result in electric shock and/or malfunction of the robot system.

CAUTION

- Whenever possible, only one person should operate the robot system. If it is necessary to operate with more than one person, ensure that all personnel communicate with each other and take all necessary safety precautions.
- Joints #1, #2, and #4:
If the Manipulator is operated repeatedly with an operating angle of 5° or less, the bearings used in the joints are likely to cause oil film shortage. Repeated operation may cause premature damage. To prevent premature damage, operate the Manipulator to move each joint to an angle of 50° or more about once per hour.
Joint #3:
If the up-and-down motion of the hand is 10 mm or less, move the hand about half or more of its maximum stroke about once per hour.
- When the robot is operating at low speed (Speed: 5 to 20%), vibration (resonance) may occur continuously during operation depending on the combination of the arm orientation and hand load. Vibration occurs due to the natural vibration frequency of the arm and can be reduced by taking the following measures:
 - Changing the robot speed
 - Changing the teach points
 - Changing the hand load

3.1.4 Emergency Stop

Each robot system needs equipment that will allow the operator to immediately stop the system's operation. Install an emergency stop device by using emergency stop input from the Controller or other equipment.

Before using the emergency stop switch, be aware of the following points.

- The emergency stop switch should be used to stop the Manipulator only in case of emergencies.
- Besides pressing the emergency stop switch when an emergency occurs, to stop the Manipulator during program operation, use the Pause or STOP (program stop) statements assigned to a standard I/O.
The Pause and STOP statements do not turn off motor energization, and so the brake is not locked.

To place the robot system in emergency stop mode in a non-emergency (normal) situation, press the emergency stop switch while the Manipulator is not operating.

Do not press the emergency stop switch unnecessarily while the Manipulator is operating normally. It could shorten the lifespan of the following components.

- Brakes
The brakes will be locked, which will shorten the lifespan of the brakes due to worn brake friction plates.
 - Normal brake lifespan:
About 2 years (when the brakes are used 100 times/day)
or about 20,000 times
- Reduction gears
An emergency stop applies an impact to the reduction gear, which can shorten its life.

If the Manipulator is stopped by turning off the Controller while it is operating, the following problems may occur.

- Reduced life and damage to reduction gear
- Position shift at the joints

If a power outage or other unavoidable Controller power-off occurs during Manipulator operation, check the following points after power is restored.

- Damage in reduction gear
- Shifting of the joints from their proper positions

If there was any shifting, maintenance is required. For more information, please contact the supplier.

Stopping distance of emergency stop

The Manipulator during operation cannot stop immediately after the emergency stop switch is pressed. Also, the stopping time and movement distance vary depending on the following factors.

- Hand weight, WEIGHT setting, ACCEL setting, workpiece weight, SPEED setting, movement posture, etc.

For the stopping time and movement distance of the Manipulator, refer to the following section.

[Appendix B: Stopping Time and Stopping Distance at Emergency Stop](#)

3.1.5 Safeguard (SG)

To maintain a safe working zone, safety barriers must be set up around the Manipulator, and safeguards must be installed at the entrance and exit of the safety barriers.

The term "safeguard" as used in this manual refers to a safety device with an interlock that allows entry into the safety barriers. Specifically, this includes safety door switches, safety barriers, light curtains, safety gates, safety floor mats, and so on. The safeguard is an input that informs the Robot Controller that an operator may be inside the safeguard area. You must assign at least one Safeguard (SG) in Safety Function Manager.

When the safeguard is opened, Protective Stop operates to change to the safeguard open state (display: SO).

- **Safeguard open**
Operations are prohibited. Further robot operation is not possible until either the safeguard is closed, the latched state is released, and a command is executed, or the TEACH or TEST operation mode is turned on and the enable circuit is activated.
- **Safeguard closed**
The robot can operate automatically in an unrestricted (high power) state.

WARNING

- If a third party accidentally releases the safeguard while an operator is working inside the safety barriers, this may result in a hazardous situation. To protect the operator working inside the safety barriers, implement measures to lock out or tag out the latch release switch.
- To protect operators working near the robot, be sure to connect a safeguard switch and make sure that it works properly.

Installing safety barriers

When installing safety barriers within the maximum range of the Manipulator, combine safety functions such as SLP. Carefully take into account the size of the hand and the workpieces to be held so that no interference occurs between the operating parts and the safety barriers.

Installing safeguards

Design the safeguards so that they satisfy the following requirements:

- When using a key switch type safety device, use a switch that forcibly opens the interlock contacts. Do not use switches that open their contacts using the spring force of the interlock.
- When using an interlock mechanism, do not disable the interlock mechanism.

Considering the stopping distance

During operation, the Manipulator cannot stop immediately even if the safeguard is opened. Also, the stopping time and movement distance vary depending on the following factors.

Hand weight, WEIGHT setting, ACCEL setting, workpiece weight, SPEED setting, movement posture, etc.

For the stopping time and movement distance of the Manipulator, refer to the following section.

[Appendix C: Stopping Time and Stopping Distance When Safeguard is Open](#)

Precautions for safeguard operation

Do not open the safeguard unnecessarily while the motor is energized. Frequent safeguard inputs will reduce the life of the relay.

- Normal relay lifespan: About 20,000 times

3.1.6 Arm Movement Method in the Emergency Stop State

In the emergency stop state, move the Manipulator joints directly by hand as shown below.

- **Joint #1:**
Push Arm #1 by hand.
- **Joint #2:**
Push Arm #2 by hand.
- **Joint #3:**
The joint cannot be moved up or down by hand because the electromagnetic brake is activated.
Move the joint while pressing down the brake release switch.

▪ **Joint #4:**

The joint cannot be rotated by hand because the electromagnetic brake is activated.
 Move the joint while pressing down the brake release switch.

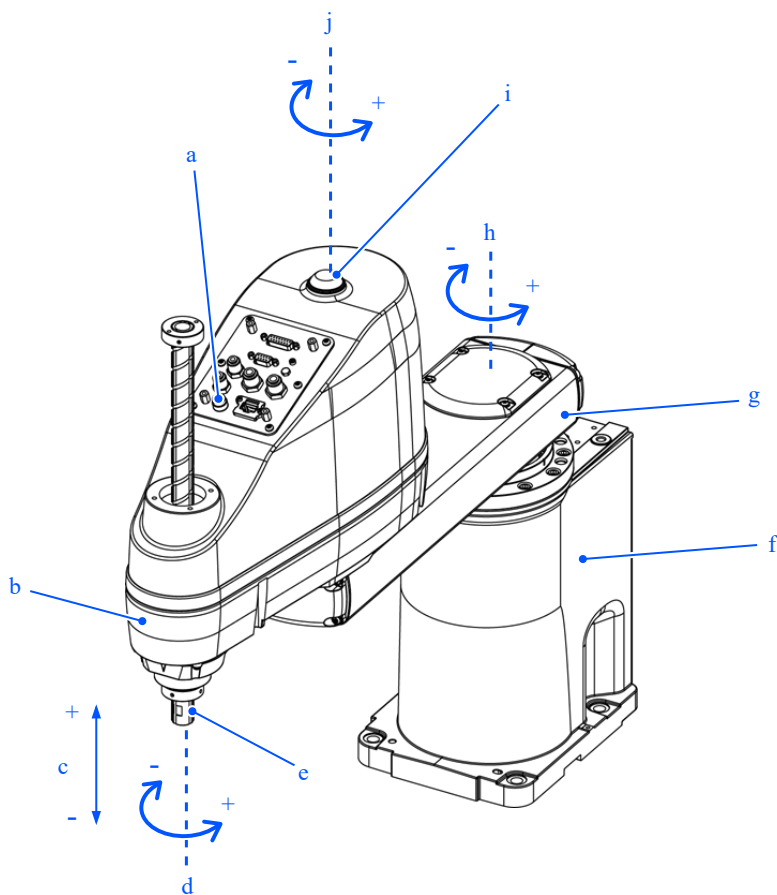

Symbol	Description
a	Joint #3 and Joint #4 brake release switch
b	Arm #2
c	Joint #3 (up/down movement)
d	Joint #4 (rotation)
e	Shaft
f	Base
g	Arm #1
h	Joint #1 (rotation)
i	Indicating lamp
j	Joint #2 (rotation)

KEY POINTS

The brake release switch is used with both Joint #3 and Joint #4. Press the brake release switch while in the emergency stop state to simultaneously release the brakes on Joint #3 and Joint #4.

When pressing the brake release switch, watch for the shaft descending or rotating under the weight of the hand.

3.1.7 ACCELS Setting for CP Motion

To make the Manipulator move in CP motion, set ACCELS properly in the SPEL program according to the tip load and the Z-axis height.

KEY POINTS

If the ACCELS settings are not properly configured, the following problem may occur.

- Shortened lifespan and damage to the ball screw spline

Set ACCELS as shown below based on the Z-axis height.

ACCELS setting values by the Z-axis height and tip load

Z-axis Height (mm)	Tip Load		
	4 kg or Less	6 kg or Less	8 kg or Less
$0 > Z \geq -100$	25000 or less	25000 or less	23500 or less
$-100 > Z \geq -200$		23000 or less	16000 or less
$-200 > Z \geq -330$		16000 or less	11500 or less

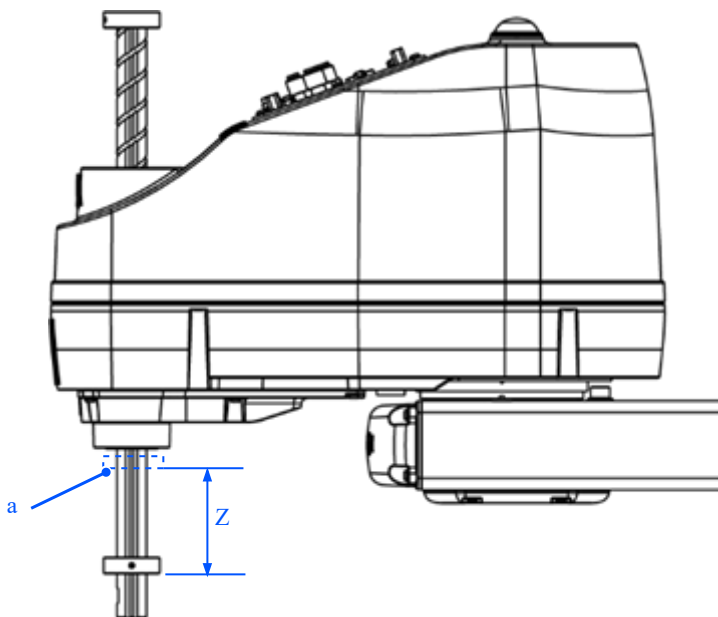

Symbol	Description
a	Z-axis height 0 (origin position)

Also, if a CP motion was performed with incorrect values set, check the following point.

- No deformation or bending of the shaft of the ball screw spline

3.1.8 Warning Labels

The Manipulator has the following warning labels.

Specific hazards exist in the vicinity of areas with the warning labels. Be thoroughly careful in handling.

To ensure that the Manipulator is operated and maintained safely, be sure to follow the safety information and warnings indicated on the warning labels. Also, do not tear, damage, or remove these warning labels.

3.1.8.1 Warning Labels

A



Touching any internal electrified parts while the power is turned on may cause electric shock.

B



The surface of the Manipulator is hot during and after operation, and there is a risk of burns.

3.1.8.2 Information Labels

1

This indicates the product name, model name, serial number, information of supported laws and regulations, product specifications (Weight, MAX.REACH, MAX.PAYLOAD, AIR PRESSURE, Motor Power), Main document No., manufacturer, importer, date of manufacture, country of manufacture, and the like.

For details, see the label affixed to the product.

2



Indicates the position of a brake release button.

3



Indicates the position of a threaded hole for an eyebolt mounting screw.

3.1.8.3 Labelled Locations

Common (Arm #2)

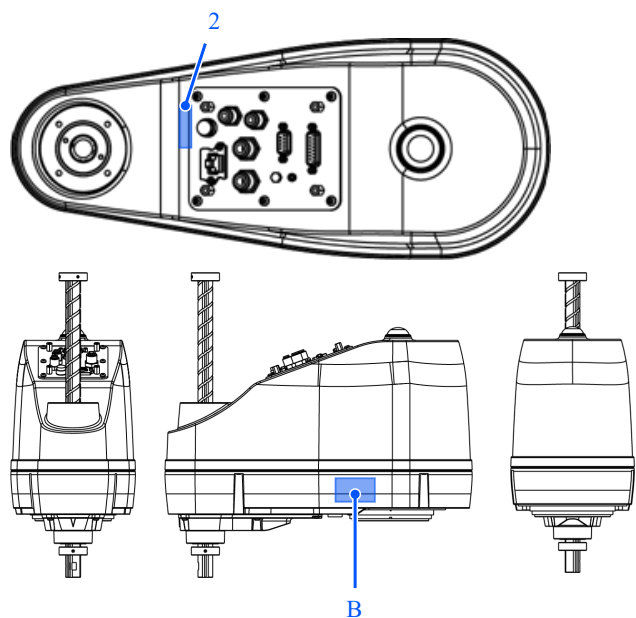

Table top mounting specifications (GX8-A/GX8-B/GX8-C****)

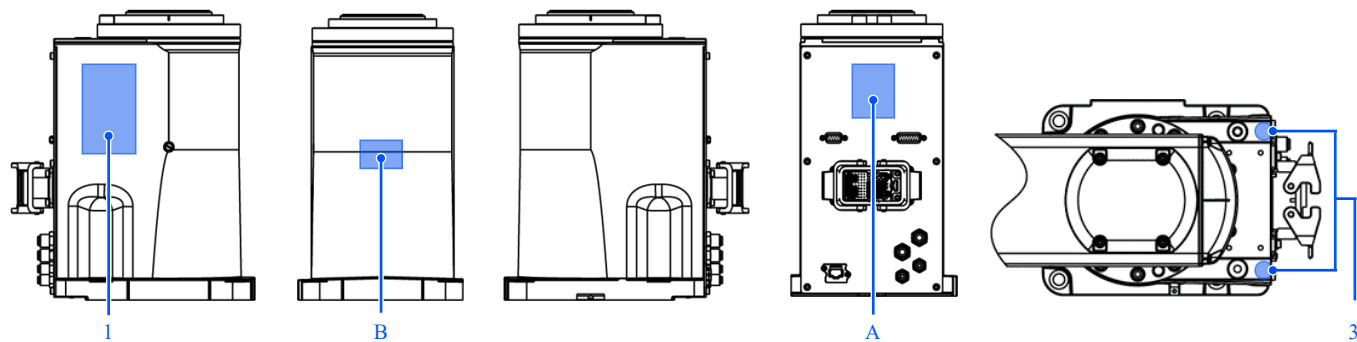
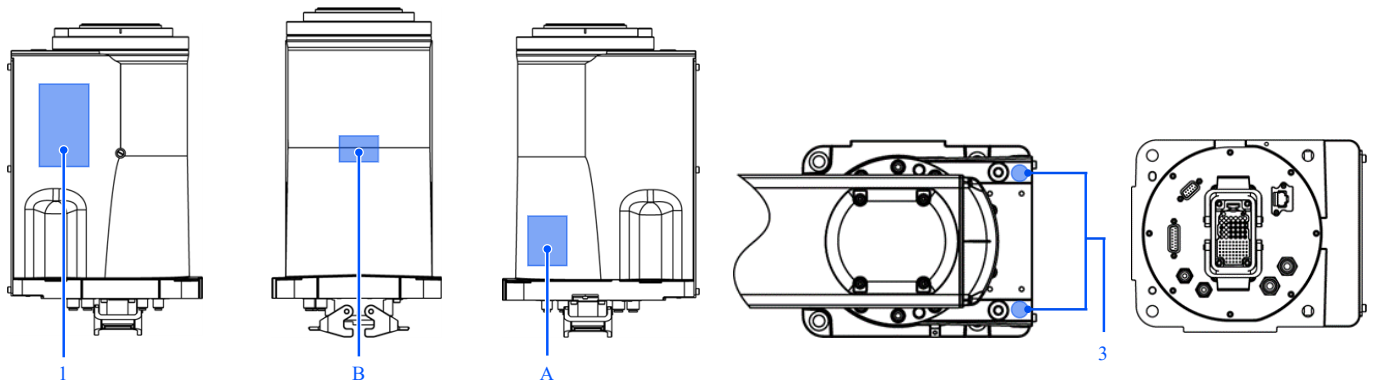
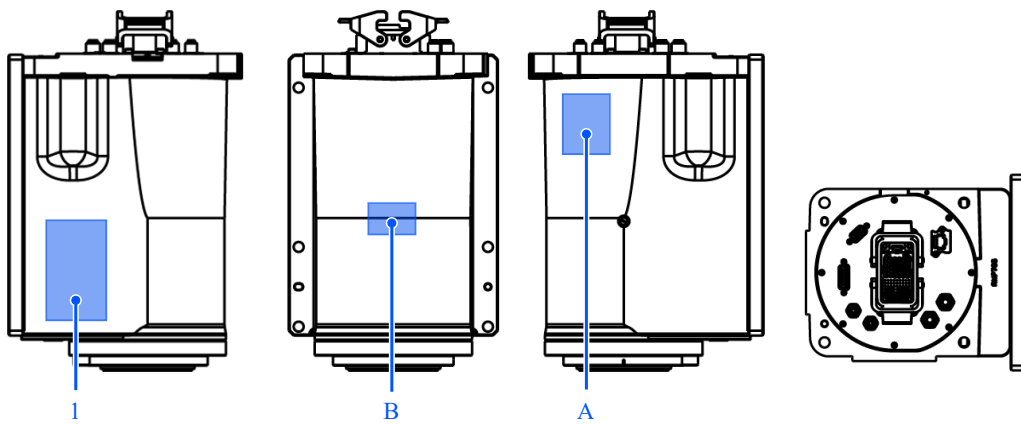

Table top mounting specifications (cable routing from bottom side)



Wall mounting specifications (GX8-A/GX8-B/GX8-C**W)**



Ceiling mounting specifications (GX8-A/GX8-B/GX8-C**R)**

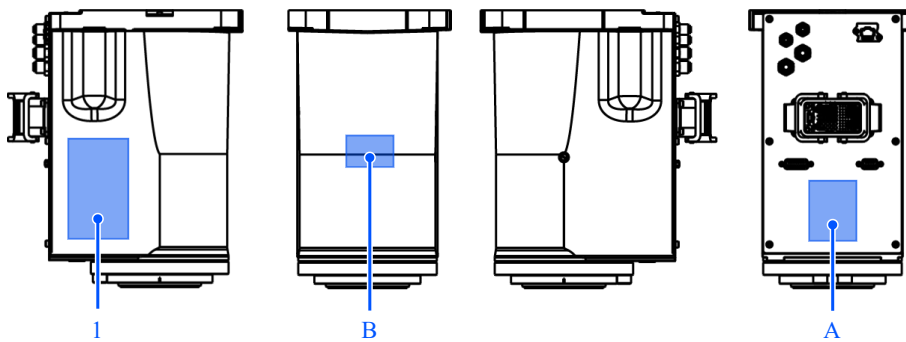

3.1.9 Responses for Emergencies or Malfunctions

3.1.9.1 When a Collision with the Manipulator Occurs

If the Manipulator has collided with a mechanical stop, peripheral device, or other object, discontinue use and contact the supplier.

3.1.9.2 Entanglement with the Manipulator

If an operator gets caught between the Manipulator and a mechanical part such as a base table, press the emergency stop switch to release the operator by using the following method.

- Operator body is entangled with a robot arm
The brake is not functioning. Move the arm manually.
- Operator body is entangled with the shaft
The brake is functioning. Press the brake release switch, and move the shaft.

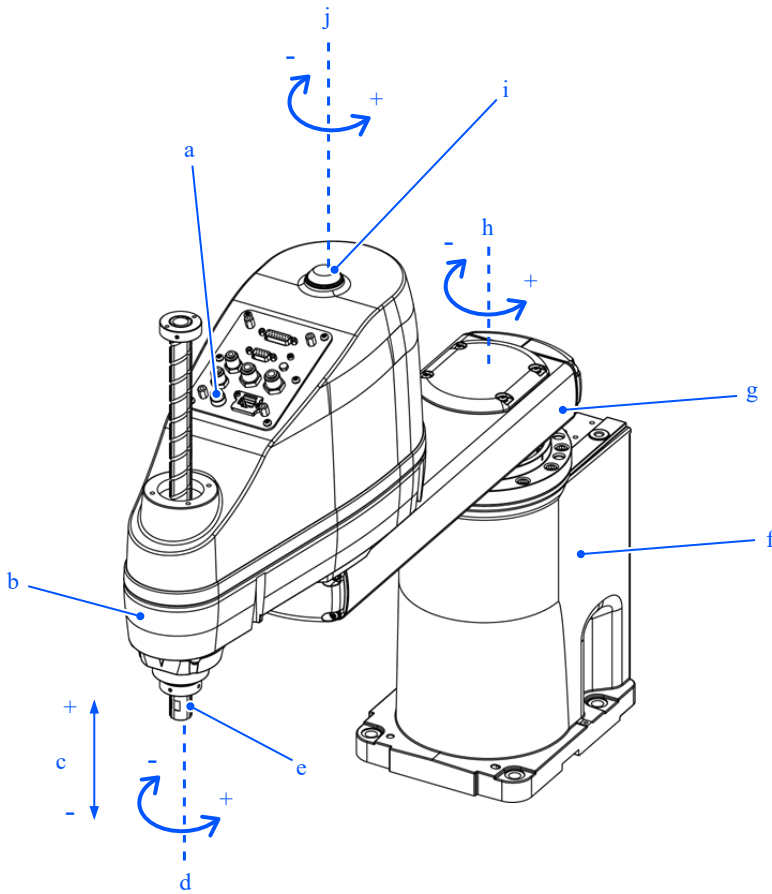

Symbol	Description
a	Joint #3 and Joint #4 brake release switch
b	Arm #2
c	Joint #3 (up/down movement)
d	Joint #4 (rotation)
e	Shaft
f	Base
g	Arm #1
h	Joint #1 (rotation)
i	Indicating lamp
j	Joint #2 (rotation)

⚠ CAUTION

- While the brake release switch is being pressed, in addition to Joint #3, Joint #4 may also move due to its own weight. Be careful of the shaft descending and rotating.

3.2 Specifications

3.2.1 Model Name GX8-A

GX8-A45 2 S

 [a] [b] [c] [d] [e] [f]

- **a: Arm length**
 45: 450 mm
 55: 550 mm
 65: 650 mm
- **b: Joint #3 stroke**
 2: 200 mm (GX8-A**2S*, E*), 170 mm (GX8-A**2C*, P*)
 3: 330 mm (GX8-A**3S*, E*), 300 mm (GX8-A**3C*, P*)
- **c: Environmental specifications**
 S: Standard (equivalent to IP20)
 E: ESD (anti-static)
 C: Cleanroom & ESD (anti-static)
 P: Protection class: IP 65
- **d: Mounting specifications**
: Table top mounting
 W: Wall mounting
 R: Ceiling mounting
- **e: Cable mounting direction**
: Standard (table top mounting - cable routing from rear side, wall mounting - cable routing from top side, ceiling mounting- cable routing from rear side)
 B: Cable routing from bottom side (table top mounting only)
- **f: Standard**
: Standard
 -UL: UL1740 certified

Environmental specifications

- ESD (anti-static) specifications: GX8-A***E*
 ESD specifications are specifications that use conductive materials for or apply plating to the major resin parts as anti-static measures.
 We have confirmed that the Manipulator tip (tool mounting section) is at ± 5 V or less, even directly after the measuring operation according to Seiko Epson standards.
 If you need any other detailed information, please contact the supplier.
 Also, please check the amount of charge on any hand, wiring, or the like that you will attach to the robot on your own before use.
- Cleanroom & ESD (anti-static) specifications: GX8-A***C*
 Manipulators with cleanroom & ESD (anti-static) specifications have a base design with the standard specifications, but as an additional feature, have reduced dust emissions from the Manipulator to enable use in cleanroom environments.
- Protected-model (IP65): GX8-A***P*
 Manipulators with protected-models have a base design with the standard specifications, but as an additional feature, can

be used in adverse environments such as those exposed to oil smoke and dust.

These are compliant with the IP65 protection class (IEC 60529, JIS C0920).

For details on the specifications, refer to the following section.

[Appendix A: Specifications Table](#)

Model list

Arm Length	Joint #3 Stroke	Environmental Specifications	Mounting Specifications	Cable Mounting Direction	Model Number
450	200	Standard	Table top	Standard	GX8-A452S
				Cable routing from bottom side	GX8-A452SB
			Wall	Standard	GX8-A452SW
			Ceiling	Standard	GX8-A452SR
450	200	ESD	Table top	Standard	GX8-A452E
				Cable routing from bottom side	GX8-A452EB
			Wall	Standard	GX8-A452EW
			Ceiling	Standard	GX8-A452ER
450	170	Cleanroom & ESD	Table top	Standard	GX8-A452C
				Cable routing from bottom side	GX8-A452CB
			Wall	Standard	GX8-A452CW
			Ceiling	Standard	GX8-A452CR
450	170	Protection	Table top	Standard	GX8-A452P
				Cable routing from bottom side	GX8-A452PB
			Wall	Standard	GX8-A452PW
			Ceiling	Standard	GX8-A452PR
450	330	Standard	Table top	Standard	GX8-A453S
				Cable routing from bottom side	GX8-A453SB
			Wall	Standard	GX8-A453SW
			Ceiling	Standard	GX8-A453SR

Arm Length	Joint #3 Stroke	Environmental Specifications	Mounting Specifications	Cable Mounting Direction	Model Number
450	330	ESD	Table top	Standard	GX8-A453E
				Cable routing from bottom side	GX8-A453EB
			Wall	Standard	GX8-A453EW
			Ceiling	Standard	GX8-A453ER
450	300	Cleanroom & ESD	Table top	Standard	GX8-A453C
				Cable routing from bottom side	GX8-A453CB
			Wall	Standard	GX8-A453CW
			Ceiling	Standard	GX8-A453CR
450	300	Protection	Table top	Standard	GX8-A453P
				Cable routing from bottom side	GX8-A453PB
			Wall	Standard	GX8-A453PW
			Ceiling	Standard	GX8-A453PR
550	200	Standard	Table top	Standard	GX8-A552S
				Cable routing from bottom side	GX8-A552SB
			Wall	Standard	GX8-A552SW
			Ceiling	Standard	GX8-A552SR
550	200	ESD	Table top	Standard	GX8-A552E
				Cable routing from bottom side	GX8-A552EB
			Wall	Standard	GX8-A552EW
			Ceiling	Standard	GX8-A552ER
550	170	Cleanroom & ESD	Table top	Standard	GX8-A552C
				Cable routing from bottom side	GX8-A552CB
			Wall	Standard	GX8-A552CW

Arm Length	Joint #3 Stroke	Environmental Specifications	Mounting Specifications	Cable Mounting Direction	Model Number
			Ceiling	Standard	GX8-A552CR
550	170	Protection	Table top	Standard	GX8-A552P
				Cable routing from bottom side	GX8-A552PB
			Wall	Standard	GX8-A552PW
			Ceiling	Standard	GX8-A552PR
550	330	Standard	Table top	Standard	GX8-A553S
				Cable routing from bottom side	GX8-A553SB
			Wall	Standard	GX8-A553SW
			Ceiling	Standard	GX8-A553SR
550	330	ESD	Table top	Standard	GX8-A553E
				Cable routing from bottom side	GX8-A553EB
			Wall	Standard	GX8-A553EW
			Ceiling	Standard	GX8-A553ER
550	300	Cleanroom & ESD	Table top	Standard	GX8-A553C
				Cable routing from bottom side	GX8-A553CB
			Wall	Standard	GX8-A553CW
			Ceiling	Standard	GX8-A553CR
550	300	Protection	Table top	Standard	GX8-A553P
				Cable routing from bottom side	GX8-A553PB
			Wall	Standard	GX8-A553PW
			Ceiling	Standard	GX8-A553PR

Arm Length	Joint #3 Stroke	Environmental Specifications	Mounting Specifications	Cable Mounting Direction	Model Number
650	200	Standard	Table top	Standard	GX8-A652S
				Cable routing from bottom side	GX8-A652SB
			Wall	Standard	GX8-A652SW
			Ceiling	Standard	GX8-A652SR
650	200	ESD	Table top	Standard	GX8-A652E
				Cable routing from bottom side	GX8-A652EB
			Wall	Standard	GX8-A652EW
			Ceiling	Standard	GX8-A652ER
650	170	Cleanroom & ESD	Table top	Standard	GX8-A652C
				Cable routing from bottom side	GX8-A652CB
			Wall	Standard	GX8-A652CW
			Ceiling	Standard	GX8-A652CR
650	170	Protection	Table top	Standard	GX8-A652P
				Cable routing from bottom side	GX8-A652PB
			Wall	Standard	GX8-A652PW
			Ceiling	Standard	GX8-A652PR
650	330	Standard	Table top	Standard	GX8-A653S
				Cable routing from bottom side	GX8-A653SB
			Wall	Standard	GX8-A653SW
			Ceiling	Standard	GX8-A653SR
650	330	ESD	Table top	Standard	GX8-A653E
				Cable routing from bottom side	GX8-A653EB
			Wall	Standard	GX8-A653EW

Arm Length	Joint #3 Stroke	Environmental Specifications	Mounting Specifications	Cable Mounting Direction	Model Number
			Ceiling	Standard	GX8-A653ER
650	300	Cleanroom & ESD	Table top	Standard	GX8-A653C
				Cable routing from bottom side	GX8-A653CB
			Wall	Standard	GX8-A653CW
			Ceiling	Standard	GX8-A653CR
650	300	Protection	Table top	Standard	GX8-A653P
				Cable routing from bottom side	GX8-A653PB
			Wall	Standard	GX8-A653PW
			Ceiling	Standard	GX8-A653PR

(Units: mm)

3.2.2 Model Name GX8-B

GX8-B45 2 S □ □
 [a] [b] [c] [d] [e]

- **a: Arm length**
 45: 450 mm
 55: 550 mm
 65: 650 mm
- **b: Joint #3 stroke**
 2: 200 mm (GX8-B**2S*, E*), 170 mm (GX8-B**2C*, P*)
 3: 330 mm (GX8-B**3S*, E*), 300 mm (GX8-B**3C*, P*)
- **c: Environmental specifications**
 S: Standard (equivalent to IP20)
 E: ESD (anti-static)
 C: Cleanroom & ESD (anti-static)
 P: Protection class: IP 65
- **d: Mounting specifications**
 □: Table top mounting
 W: Wall mounting
 R: Ceiling mounting
- **e: Cable mounting direction**
 □: Standard (table top mounting - cable routing from rear side, wall mounting - cable routing from top side, ceiling mounting- cable routing from rear side)
 B: Cable routing from bottom side (table top mounting only)

Environmental specifications

- ESD (anti-static) specifications: GX8-B***E*
 ESD specifications are specifications that use conductive materials for or apply plating to the major resin parts as anti-static measures.
 We have confirmed that the Manipulator tip (tool mounting section) is at ± 5 V or less, even directly after the measuring operation according to Seiko Epson standards.
 If you need any other detailed information, please contact the supplier.
 Also, please check the amount of charge on any hand, wiring, or the like that you will attach to the robot on your own before use.
- Cleanroom & ESD (anti-static) specifications: GX8-B***C*
 Manipulators with cleanroom & ESD (anti-static) specifications have a base design with the standard specifications, but as an additional feature, have reduced dust emissions from the Manipulator to enable use in cleanroom environments.
- Protected-model (IP65): GX8-B***P*
 Manipulators with protected-models have a base design with the standard specifications, but as an additional feature, can be used in adverse environments such as those exposed to oil smoke and dust.
 These are compliant with the IP65 protection class (IEC 60529, JIS C0920).

Food grade grease model (GX8-B**3P-FZ)

- Food grade grease model have the grease for Z-axis ball screw splines which is usable for foods. Customer is responsible for integrating into food processing machinery and complying with related laws, regulations, and standards.
- Food grade grease models are made up of a combination of the following Controller and software.

Manipulator	Controller	Software
GX8-B**3P-FZ	RC700-E	EPSON RC+ 7.0 Ver.7.5.4

- Be sure to use the specified grease for food specification machine. For details, refer to the following section.
[Applying Grease](#)

For details on the specifications, refer to the following section.

[Appendix A: Specifications Table](#)

Model list

Arm Length	Joint #3 Stroke	Environmental Specifications	Mounting Specifications	Cable Mounting Direction	Model Number
450	200	Standard	Table top	Standard	GX8-B452S
				Cable routing from bottom side	GX8-B452SB
			Wall	Standard	GX8-B452SW
			Ceiling	Standard	GX8-B452SR
450	200	ESD	Table top	Standard	GX8-B452E
				Cable routing from bottom side	GX8-B452EB
			Wall	Standard	GX8-B452EW
			Ceiling	Standard	GX8-B452ER
450	170	Cleanroom & ESD	Table top	Standard	GX8-B452C
				Cable routing from bottom side	GX8-B452CB
			Wall	Standard	GX8-B452CW
			Ceiling	Standard	GX8-B452CR
450	170	Protection	Table top	Standard	GX8-B452P
				Cable routing from bottom side	GX8-B452PB
			Wall	Standard	GX8-B452PW
			Ceiling	Standard	GX8-B452PR
450	330	Standard	Table top	Standard	GX8-B453S
				Cable routing from bottom side	GX8-B453SB
			Wall	Standard	GX8-B453SW
			Ceiling	Standard	GX8-B453SR

Arm Length	Joint #3 Stroke	Environmental Specifications	Mounting Specifications	Cable Mounting Direction	Model Number
450	330	ESD	Table top	Standard	GX8-B453E
				Cable routing from bottom side	GX8-B453EB
			Wall	Standard	GX8-B453EW
			Ceiling	Standard	GX8-B453ER
450	300	Cleanroom & ESD	Table top	Standard	GX8-B453C
				Cable routing from bottom side	GX8-B453CB
			Wall	Standard	GX8-B453CW
			Ceiling	Standard	GX8-B453CR
450	300	Protection	Table top	Standard	GX8-B453P
				Cable routing from bottom side	GX8-B453PB
			Wall	Standard	GX8-B453PW
			Ceiling	Standard	GX8-B453PR
550	200	Standard	Table top	Standard	GX8-B552S
				Cable routing from bottom side	GX8-B552SB
			Wall	Standard	GX8-B552SW
			Ceiling	Standard	GX8-B552SR
550	200	ESD	Table top	Standard	GX8-B552E
				Cable routing from bottom side	GX8-B552EB
			Wall	Standard	GX8-B552EW
			Ceiling	Standard	GX8-B552ER
550	170	Cleanroom & ESD	Table top	Standard	GX8-B552C
				Cable routing from bottom side	GX8-B552CB
			Wall	Standard	GX8-B552CW

Arm Length	Joint #3 Stroke	Environmental Specifications	Mounting Specifications	Cable Mounting Direction	Model Number
			Ceiling	Standard	GX8-B552CR
550	170	Protection	Table top	Standard	GX8-B552P
				Cable routing from bottom side	GX8-B552PB
			Wall	Standard	GX8-B552PW
			Ceiling	Standard	GX8-B552PR
550	330	Standard	Table top	Standard	GX8-B553S
				Cable routing from bottom side	GX8-B553SB
			Wall	Standard	GX8-B553SW
			Ceiling	Standard	GX8-B553SR
550	330	ESD	Table top	Standard	GX8-B553E
				Cable routing from bottom side	GX8-B553EB
			Wall	Standard	GX8-B553EW
			Ceiling	Standard	GX8-B553ER
550	300	Cleanroom & ESD	Table top	Standard	GX8-B553C
				Cable routing from bottom side	GX8-B553CB
			Wall	Standard	GX8-B553CW
			Ceiling	Standard	GX8-B553CR
550	300	Protection	Table top	Standard	GX8-B553P
				Cable routing from bottom side	GX8-B553PB
			Wall	Standard	GX8-B553PW
			Ceiling	Standard	GX8-B553PR

Arm Length	Joint #3 Stroke	Environmental Specifications	Mounting Specifications	Cable Mounting Direction	Model Number
650	200	Standard	Table top	Standard	GX8-B652S
				Cable routing from bottom side	GX8-B652SB
			Wall	Standard	GX8-B652SW
			Ceiling	Standard	GX8-B652SR
650	200	ESD	Table top	Standard	GX8-B652E
				Cable routing from bottom side	GX8-B652EB
			Wall	Standard	GX8-B652EW
			Ceiling	Standard	GX8-B652ER
650	170	Cleanroom & ESD	Table top	Standard	GX8-B652C
				Cable routing from bottom side	GX8-B652CB
			Wall	Standard	GX8-B652CW
			Ceiling	Standard	GX8-B652CR
650	170	Protection	Table top	Standard	GX8-B652P
				Cable routing from bottom side	GX8-B652PB
			Wall	Standard	GX8-B652PW
			Ceiling	Standard	GX8-B652PR
650	330	Standard	Table top	Standard	GX8-B653S
				Cable routing from bottom side	GX8-B653SB
			Wall	Standard	GX8-B653SW
			Ceiling	Standard	GX8-B653SR
650	330	ESD	Table top	Standard	GX8-B653E
				Cable routing from bottom side	GX8-B653EB
			Wall	Standard	GX8-B653EW

Arm Length	Joint #3 Stroke	Environmental Specifications	Mounting Specifications	Cable Mounting Direction	Model Number
			Ceiling	Standard	GX8-B653ER
650	300	Cleanroom & ESD	Table top	Standard	GX8-B653C
				Cable routing from bottom side	GX8-B653CB
			Wall	Standard	GX8-B653CW
			Ceiling	Standard	GX8-B653CR
650	300	Protection	Table top	Standard	GX8-B653P
				Cable routing from bottom side	GX8-B653PB
			Wall	Standard	GX8-B653PW
			Ceiling	Standard	GX8-B653PR

(Units: mm)

3.2.3 Model Name GX8-C

GX8-C45 2 S □ □
 [a] [b] [c] [d] [e]

- **a: Arm length**
 45: 450 mm
 55: 550 mm
 65: 650 mm
- **b: Joint #3 stroke**
 2: 200 mm (GX8-C**2S*, E*), 170 mm (GX8-C**2C*, P*)
 3: 330 mm (GX8-C**3S*, E*), 300 mm (GX8-C**3C*, P*)
- **c: Environmental specifications**
 S: Standard (equivalent to IP20)
 E: ESD (anti-static)
 C: Cleanroom & ESD (anti-static)
 P: Protection class: IP 65
- **d: Mounting specifications**
 □: Table top mounting
 W: Wall mounting
 R: Ceiling mounting
- **e: Cable mounting direction**
 □: Standard (table top mounting - cable routing from rear side, wall mounting - cable routing from top side, ceiling mounting- cable routing from rear side)
 B: Cable routing from bottom side (table top mounting only)

Environmental specifications

- ESD (anti-static) specifications: GX8-C***E*
 ESD specifications are specifications that use conductive materials for or apply plating to the major resin parts as anti-static measures.
 We have confirmed that the Manipulator tip (tool mounting section) is at ± 5 V or less, even directly after the measuring operation according to Seiko Epson standards.
 If you need any other detailed information, please contact the supplier.
 Also, please check the amount of charge on any hand, wiring, or the like that you will attach to the robot on your own before use.
- Cleanroom & ESD (anti-static) specifications: GX8-C***C*
 Manipulators with cleanroom & ESD (anti-static) specifications have a base design with the standard specifications, but as an additional feature, have reduced dust emissions from the Manipulator to enable use in cleanroom environments.
- Protected-model (IP65): GX8-C***P*
 Manipulators with protected-models have a base design with the standard specifications, but as an additional feature, can be used in adverse environments such as those exposed to oil smoke and dust.
 These are compliant with the IP65 protection class (IEC 60529, JIS C0920).

For details on the specifications, refer to the following section.

[Appendix A: Specifications Table](#)

Model list

Arm Length	Joint #3 Stroke	Environmental Specifications	Mounting Specifications	Cable Mounting Direction	Model Number
450	200	Standard	Table top	Standard	GX8-C452S
				Cable routing from bottom side	GX8-C452SB
			Wall	Standard	GX8-C452SW
			Ceiling	Standard	GX8-C452SR
450	200	ESD	Table top	Standard	GX8-C452E
				Cable routing from bottom side	GX8-C452EB
			Wall	Standard	GX8-C452EW
			Ceiling	Standard	GX8-C452ER
450	170	Cleanroom & ESD	Table top	Standard	GX8-C452C
				Cable routing from bottom side	GX8-C452CB
			Wall	Standard	GX8-C452CW
			Ceiling	Standard	GX8-C452CR
450	170	Protection	Table top	Standard	GX8-C452P
				Cable routing from bottom side	GX8-C452PB
			Wall	Standard	GX8-C452PW
			Ceiling	Standard	GX8-C452PR
450	330	Standard	Table top	Standard	GX8-C453S
				Cable routing from bottom side	GX8-C453SB
			Wall	Standard	GX8-C453SW
			Ceiling	Standard	GX8-C453SR

Arm Length	Joint #3 Stroke	Environmental Specifications	Mounting Specifications	Cable Mounting Direction	Model Number
450	330	ESD	Table top	Standard	GX8-C453E
				Cable routing from bottom side	GX8-C453EB
			Wall	Standard	GX8-C453EW
			Ceiling	Standard	GX8-C453ER
450	300	Cleanroom & ESD	Table top	Standard	GX8-C453C
				Cable routing from bottom side	GX8-C453CB
			Wall	Standard	GX8-C453CW
			Ceiling	Standard	GX8-C453CR
450	300	Protection	Table top	Standard	GX8-C453P
				Cable routing from bottom side	GX8-C453PB
			Wall	Standard	GX8-C453PW
			Ceiling	Standard	GX8-C453PR
550	200	Standard	Table top	Standard	GX8-C552S
				Cable routing from bottom side	GX8-C552SB
			Wall	Standard	GX8-C552SW
			Ceiling	Standard	GX8-C552SR
550	200	ESD	Table top	Standard	GX8-C552E
				Cable routing from bottom side	GX8-C552EB
			Wall	Standard	GX8-C552EW
			Ceiling	Standard	GX8-C552ER
550	170	Cleanroom & ESD	Table top	Standard	GX8-C552C
				Cable routing from bottom side	GX8-C552CB
			Wall	Standard	GX8-C552CW

Arm Length	Joint #3 Stroke	Environmental Specifications	Mounting Specifications	Cable Mounting Direction	Model Number
			Ceiling	Standard	GX8-C552CR
550	170	Protection	Table top	Standard	GX8-C552P
				Cable routing from bottom side	GX8-C552PB
			Wall	Standard	GX8-C552PW
			Ceiling	Standard	GX8-C552PR
550	330	Standard	Table top	Standard	GX8-C553S
				Cable routing from bottom side	GX8-C553SB
			Wall	Standard	GX8-C553SW
			Ceiling	Standard	GX8-C553SR
550	330	ESD	Table top	Standard	GX8-C553E
				Cable routing from bottom side	GX8-C553EB
			Wall	Standard	GX8-C553EW
			Ceiling	Standard	GX8-C553ER
550	300	Cleanroom & ESD	Table top	Standard	GX8-C553C
				Cable routing from bottom side	GX8-C553CB
			Wall	Standard	GX8-C553CW
			Ceiling	Standard	GX8-C553CR
550	300	Protection	Table top	Standard	GX8-C553P
				Cable routing from bottom side	GX8-C553PB
			Wall	Standard	GX8-C553PW
			Ceiling	Standard	GX8-C553PR

Arm Length	Joint #3 Stroke	Environmental Specifications	Mounting Specifications	Cable Mounting Direction	Model Number
650	200	Standard	Table top	Standard	GX8-C652S
				Cable routing from bottom side	GX8-C652SB
			Wall	Standard	GX8-C652SW
			Ceiling	Standard	GX8-C652SR
650	200	ESD	Table top	Standard	GX8-C652E
				Cable routing from bottom side	GX8-C652EB
			Wall	Standard	GX8-C652EW
			Ceiling	Standard	GX8-C652ER
650	170	Cleanroom & ESD	Table top	Standard	GX8-C652C
				Cable routing from bottom side	GX8-C652CB
			Wall	Standard	GX8-C652CW
			Ceiling	Standard	GX8-C652CR
650	170	Protection	Table top	Standard	GX8-C652P
				Cable routing from bottom side	GX8-C652PB
			Wall	Standard	GX8-C652PW
			Ceiling	Standard	GX8-C652PR
650	330	Standard	Table top	Standard	GX8-C653S
				Cable routing from bottom side	GX8-C653SB
			Wall	Standard	GX8-C653SW
			Ceiling	Standard	GX8-C653SR
650	330	ESD	Table top	Standard	GX8-C653E
				Cable routing from bottom side	GX8-C653EB
			Wall	Standard	GX8-C653EW

Arm Length	Joint #3 Stroke	Environmental Specifications	Mounting Specifications	Cable Mounting Direction	Model Number
			Ceiling	Standard	GX8-C653ER
650	300	Cleanroom & ESD	Table top	Standard	GX8-C653C
				Cable routing from bottom side	GX8-C653CB
			Wall	Standard	GX8-C653CW
			Ceiling	Standard	GX8-C653CR
650	300	Protection	Table top	Standard	GX8-C653P
				Cable routing from bottom side	GX8-C653PB
			Wall	Standard	GX8-C653PW
			Ceiling	Standard	GX8-C653PR

(Units: mm)

3.2.4 Names of Parts and Their Dimensions

3.2.4.1 Table Top Mounting Specifications

3.2.4.1.1 Cable Mounting Direction: Standard

Standard specifications GX8-A/GX8-B/GX8-C***S

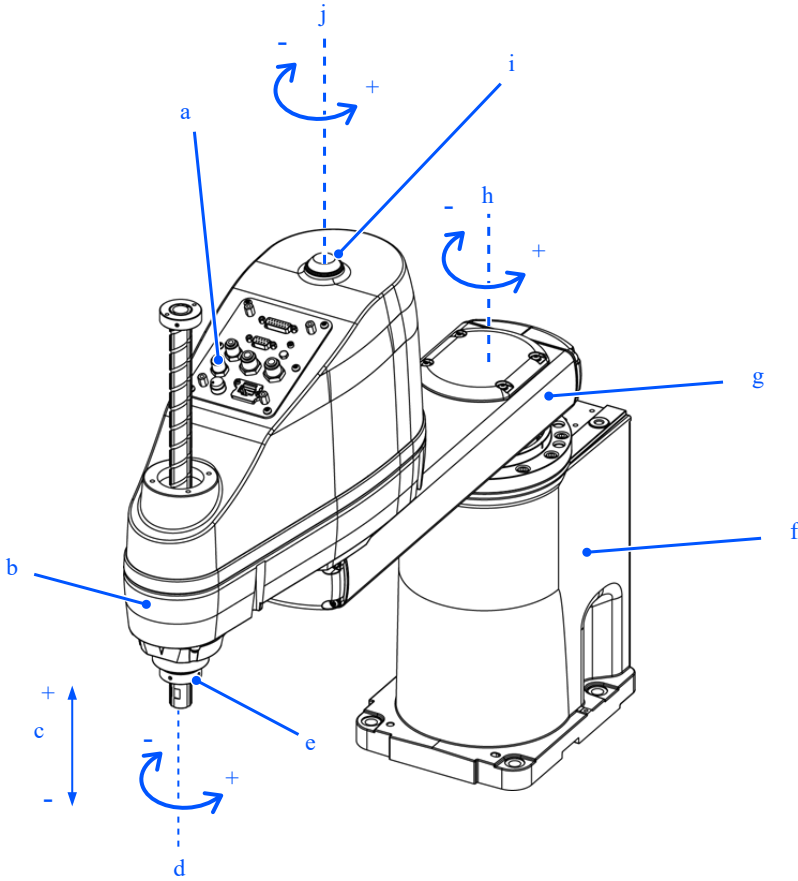

Symbol	Description
a	Joint #3 and Joint #4 brake release switch
b	Arm #2
c	Joint #3 (up/down movement)
d	Joint #4 (rotation)
e	Shaft
f	Base
g	Arm #1
h	Joint #1 (rotation)
i	Indicating lamp
j	Joint #2 (rotation)

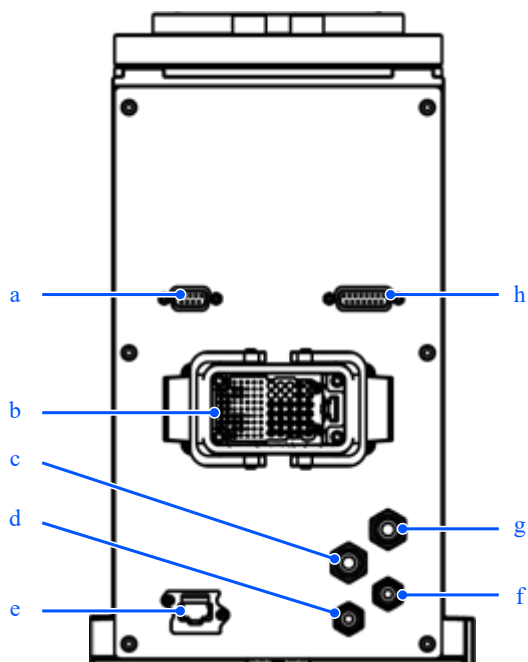

Symbol	Description
a	User connector (9-pin D-sub connector)
b	M/C cable housing
c	Fitting for $\varnothing 6$ mm tube (blue)
d	Fitting for $\varnothing 4$ mm tube (blue)
e	User connector (Ethernet connector)
f	Fitting for $\varnothing 4$ mm tube (white)
g	Fitting for $\varnothing 6$ mm tube (white)
h	User connector (15-pin D-sub connector)

KEY POINTS

- The brake release switch is used with both Joint #3 and Joint #4. Press the brake release switch while in the emergency stop state to simultaneously release the brakes on Joint #3 and Joint #4.
- Before starting any maintenance work, be sure to turn off the Controller and inform others in the surrounding area that work is in progress. Performing any work procedure with the power turned on is extremely dangerous and may result in electric shock and/or malfunction of the robot system.

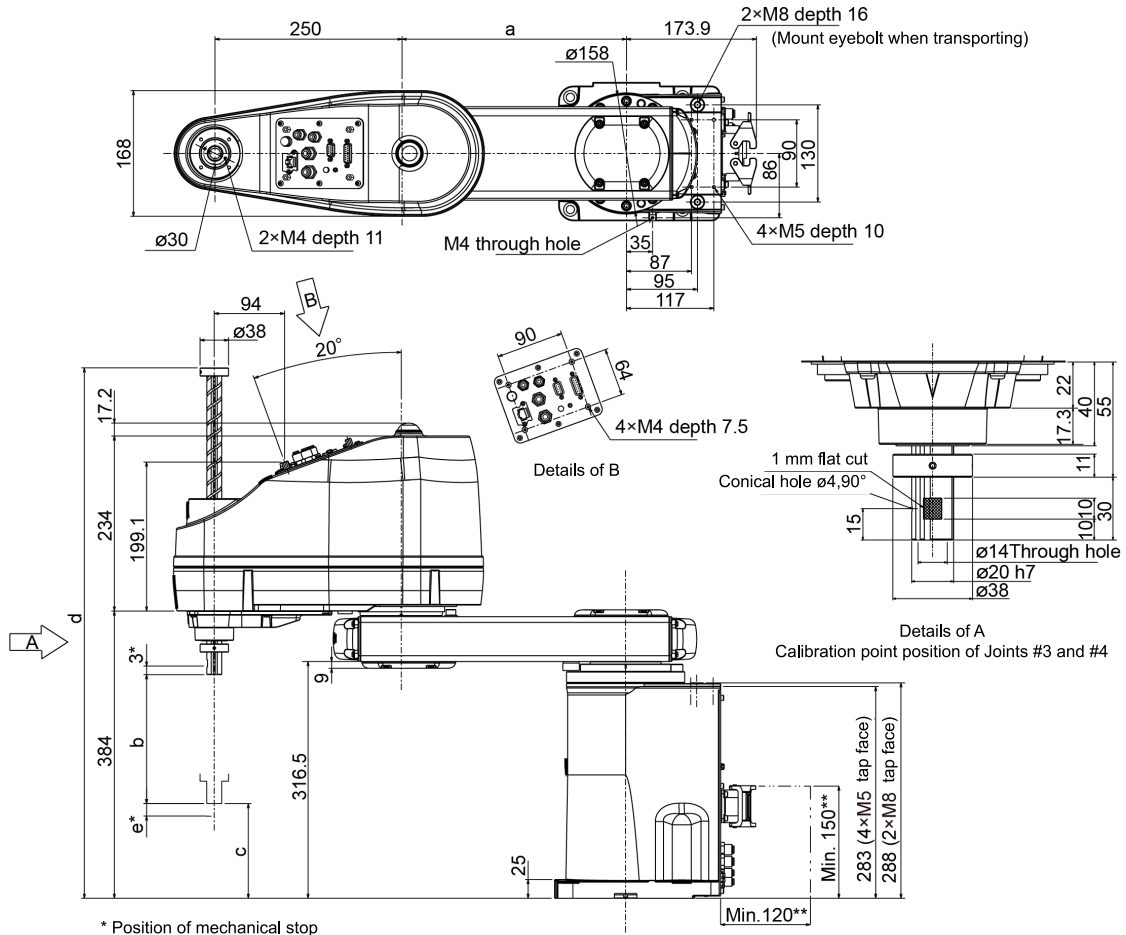

* Position of mechanical stop

** Space for connector

	GX8-A/GX8-B/ GX8-C452S, E	GX8-A/GX8-B/ GX8-C453S, E	GX8-A/GX8-B/ GX8-C552S, E	GX8-A/GX8-B/ GX8-C553S, E	GX8-A/GX8-B/ GX8-C652S, E	GX8-A/GX8-B/ GX8-C653S, E
a	200	200	300	300	400	400
b	200	330	200	330	200	330
c	99	-31	99	-31	99	-31
d	709	834	709	834	709	834
e	15.6	10.6	15.6	10.6	15.6	10.6

ESD specifications GX8-A/GX8-B/GX8-C*E**

The parts shown below differ from the standard specifications. The external dimensions are identical.

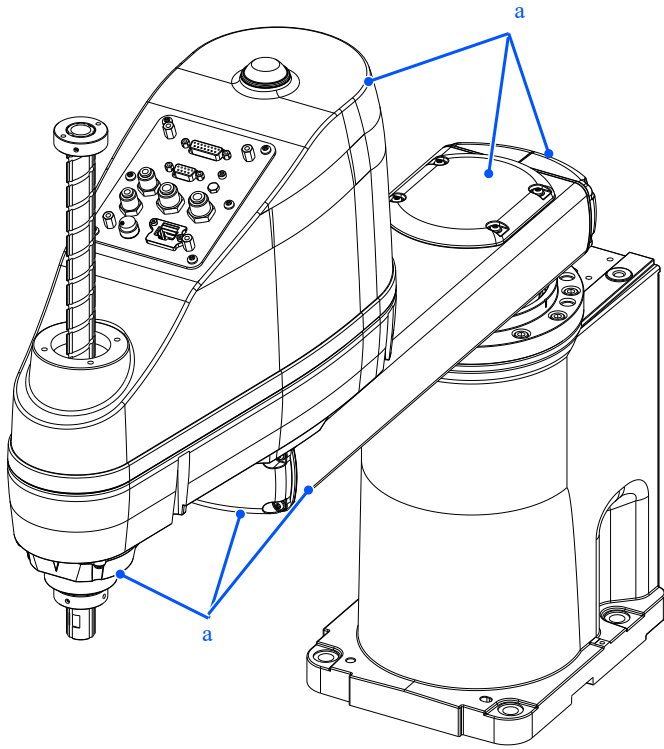

Symbol	Description
a	Plating covers (anti-static specifications)

Cleanroom & ESD specifications GX8-A/GX8-B/GX8-C*C**

The parts shown below differ from the standard specifications.

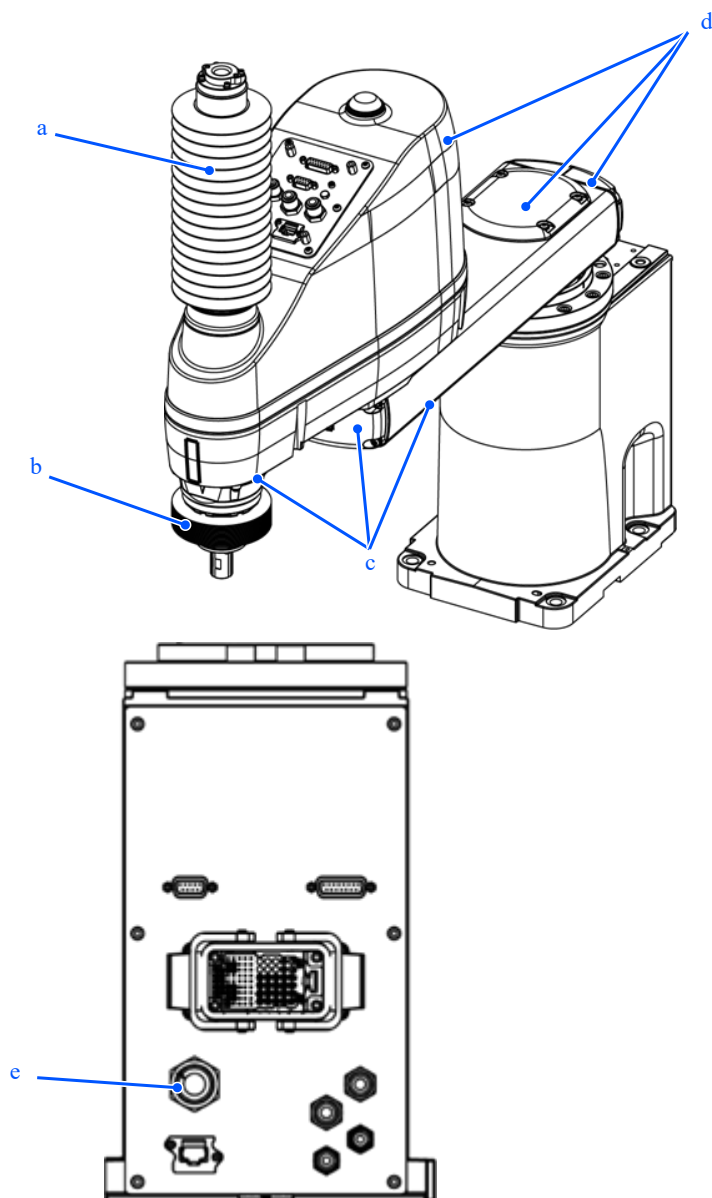

Symbol	Description
a	Upper bellows
b	Lower bellows
c	Plating covers (anti-static specifications)
d	Plating covers (anti-static specifications)
e	Exhaust port

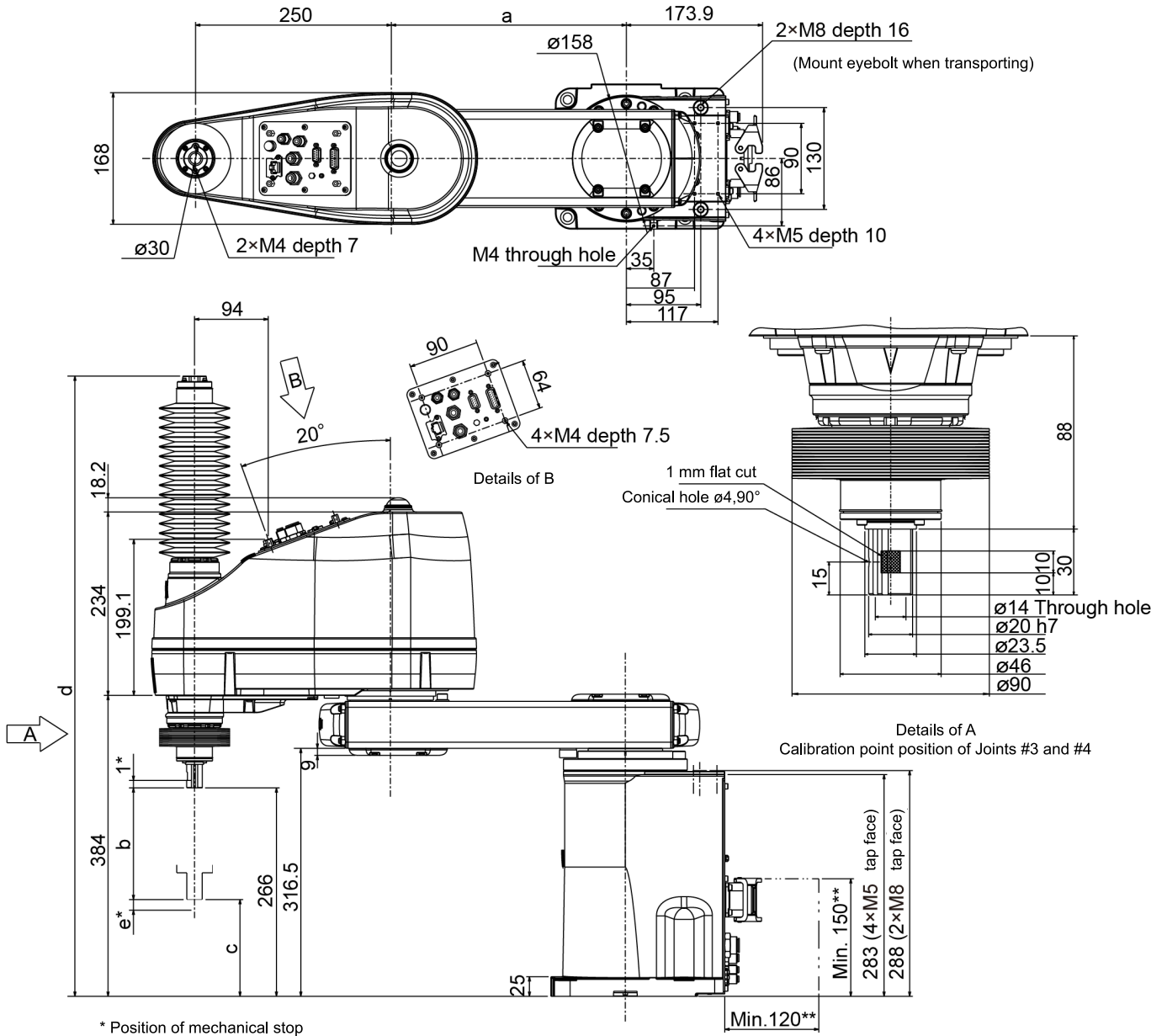

* Position of mechanical stop

** Space for connector

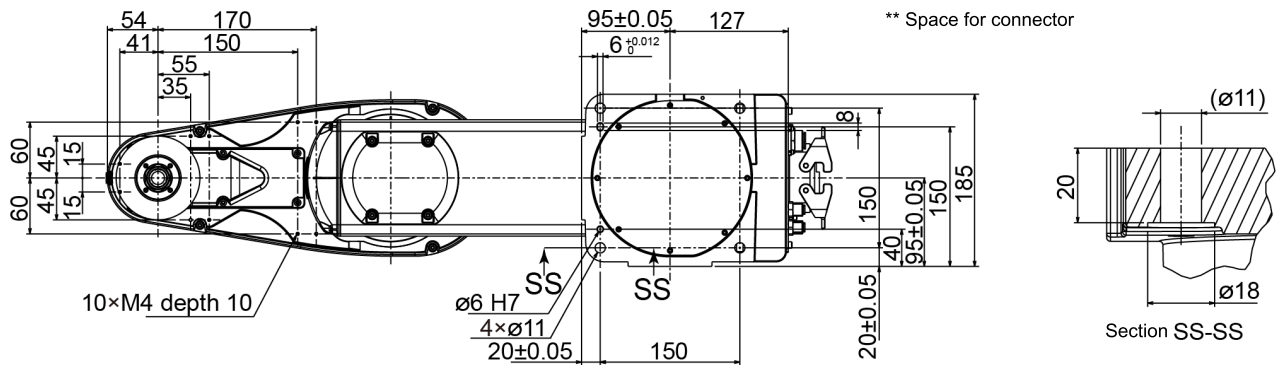

	GX8-A/GX8-B/ GX8-C452C	GX8-A/GX8-B/ GX8-C453C	GX8-A/GX8-B/ GX8-C552C	GX8-A/GX8-B/ GX8-C553C	GX8-A/GX8-B/ GX8-C652C	GX8-A/GX8-B/ GX8-C653C
a	200	200	300	300	400	400
b	170	300	170	300	170	300
c	96	-34	96	-34	96	-34
d	791.5	910.5	791.5	910.5	791.5	910.5
e	12.6	7.6	12.6	7.6	12.6	7.6

Protected-models GX8-A/GX8-B/GX8-C*P**

The parts shown below differ from the standard specifications.

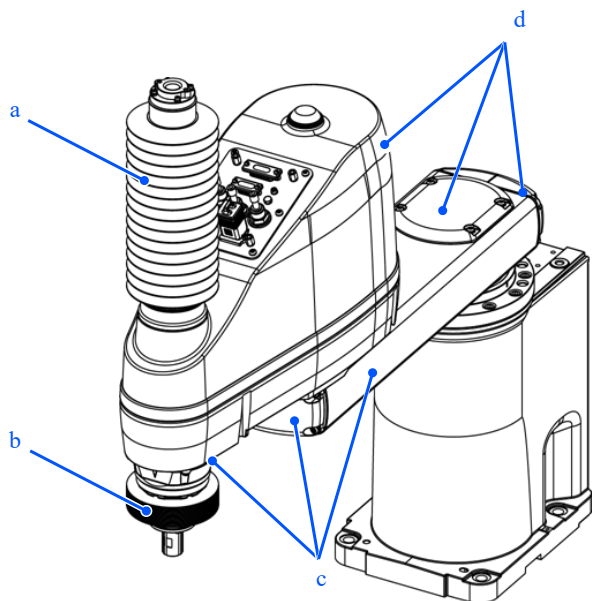

Symbol	Description
a	Upper bellows
b	Lower bellows
c	Plating cover (oil-resistant specifications)
d	Plating cover (oil-resistant specifications)

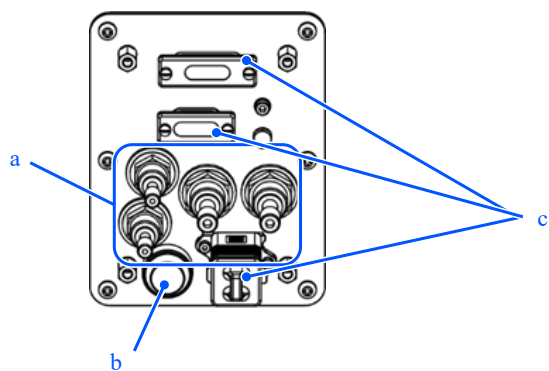

Symbol	Description
a	Fittings with cover (protected-model)
b	Joint #3 and Joint #4 brake release switch (protected-model)
c	User connectors with cover (protected-model)

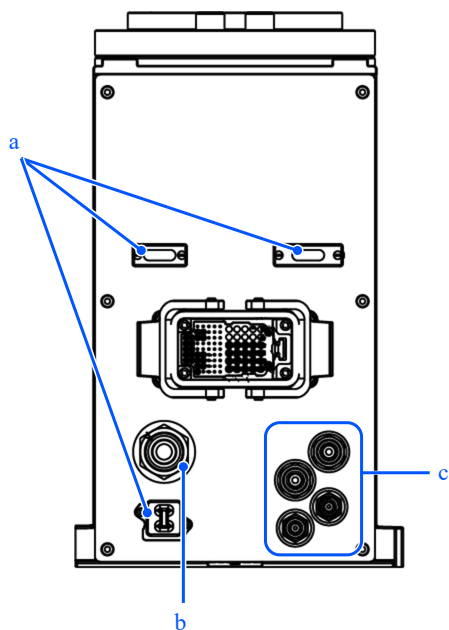

Symbol	Description
a	User connectors with cover (protected-model)
b	Exhaust port with cover
c	Fittings with cover (protected-model)

KEY POINTS

- For protected-models, all screws used for the exterior are stainless steel screws. (except for screws used for stops).
- The part of the M/C cable housing is not IP65 compliant when the M/C cable hood is not connected.

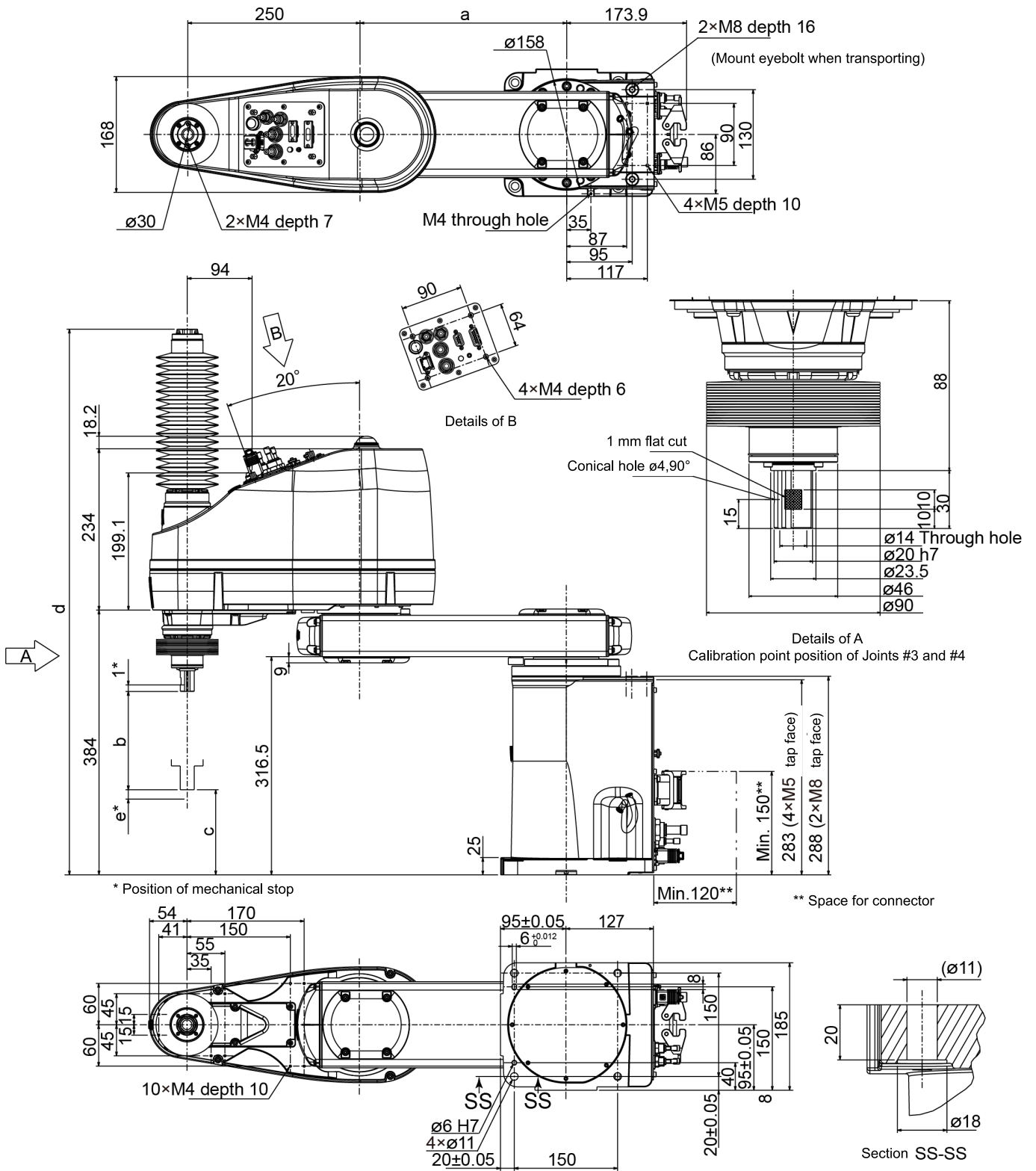

	GX8-A/GX8-B/ GX8-C452P	GX8-A/GX8-B/ GX8-C453P	GX8-A/GX8-B/ GX8-C552P	GX8-A/GX8-B/ GX8-C553P	GX8-A/GX8-B/ GX8-C652P	GX8-A/GX8-B/ GX8-C653P
a	200	200	300	300	400	400
b	170	300	170	300	170	300
c	96	-34	96	-34	96	-34
d	791.5	910.5	791.5	910.5	791.5	910.5
e	12.6	7.6	12.6	7.6	12.6	7.6

3.2.4.1.2 Cable Mounting Direction: Cable Routing from Bottom Side

Standard specifications GX8-A/GX8-B/GX8-C***SB

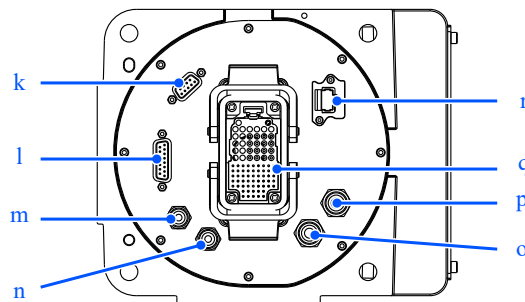
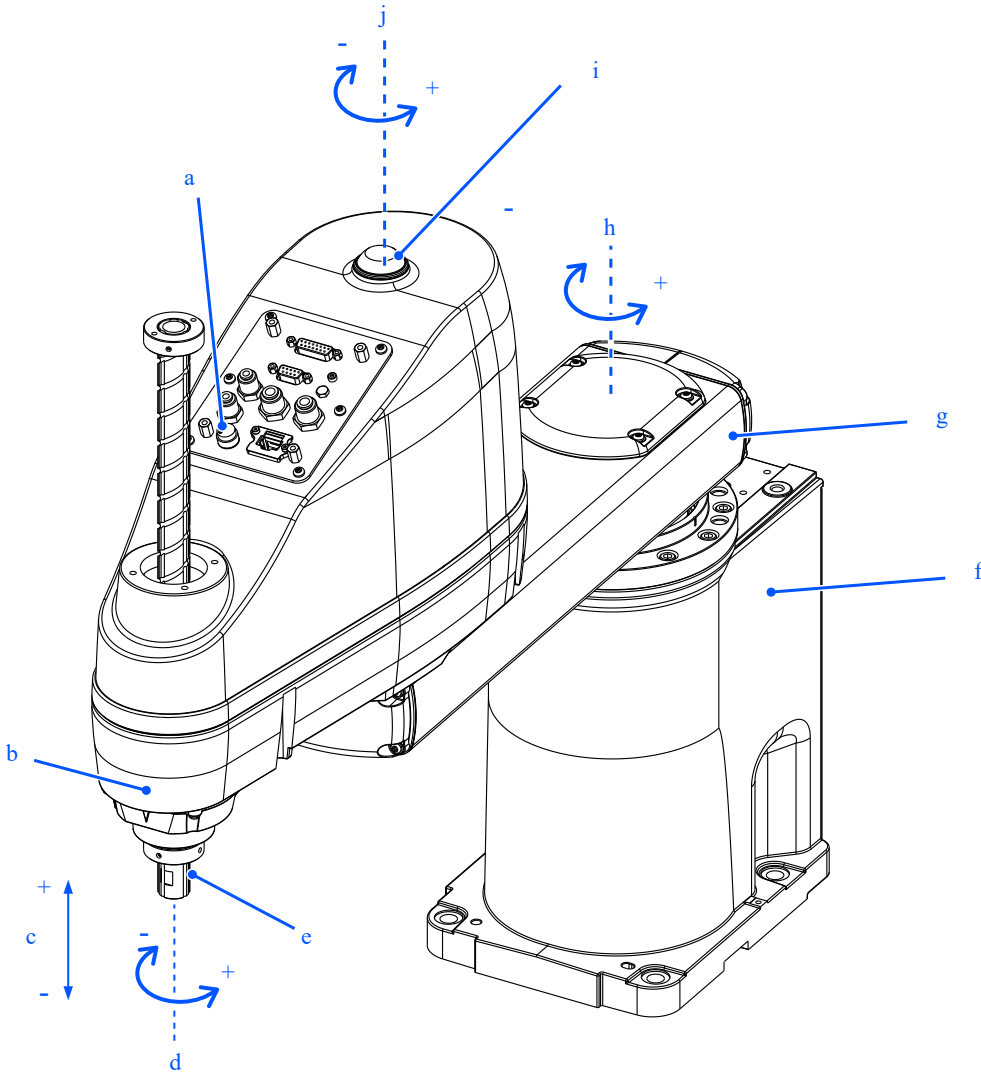

Symbol	Description
a	Joint #3 and Joint #4 brake release switch
b	Arm #2
c	Joint #3 (up/down movement)
d	Joint #4 (rotation)

Symbol	Description
e	Shaft
f	Base
g	Arm #1
h	Joint #1 (rotation)
i	Indicating lamp
j	Joint #2 (rotation)
k	User connector (9-pin D-sub connector)
l	User connector (15-pin D-sub connector)
m	Fitting for $\varnothing 4$ mm tube (blue)
n	Fitting for $\varnothing 4$ mm tube (white)
o	Fitting for $\varnothing 6$ mm tube (blue)
p	Fitting for $\varnothing 6$ mm tube (white)
q	M/C cable housing
r	User connector (Ethernet connector)

KEY POINTS

- The brake release switch is used with both Joint #3 and Joint #4. Press the brake release switch while in the emergency stop state to simultaneously release the brakes on Joint #3 and Joint #4.
- Before starting any maintenance work, be sure to turn off the Controller and inform others in the surrounding area that work is in progress. Performing any work procedure with the power turned on is extremely dangerous and may result in electric shock and/or malfunction of the robot system.

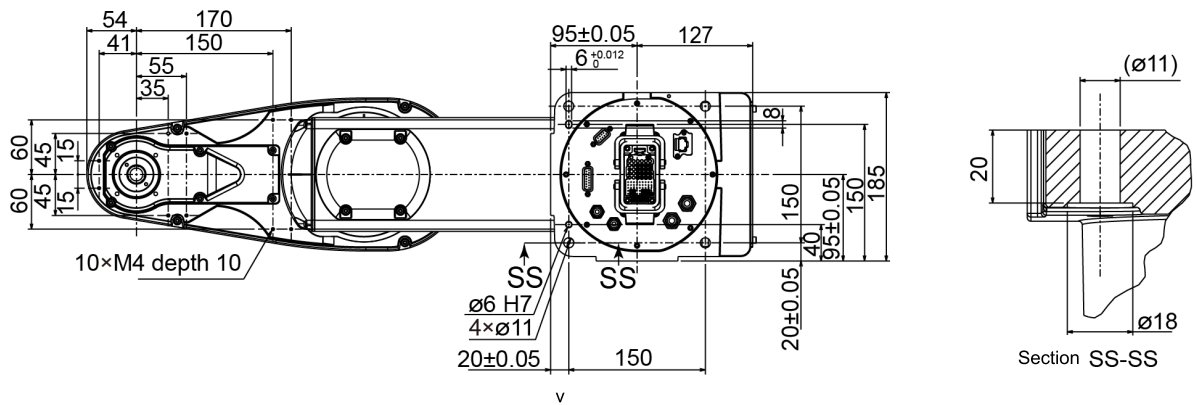
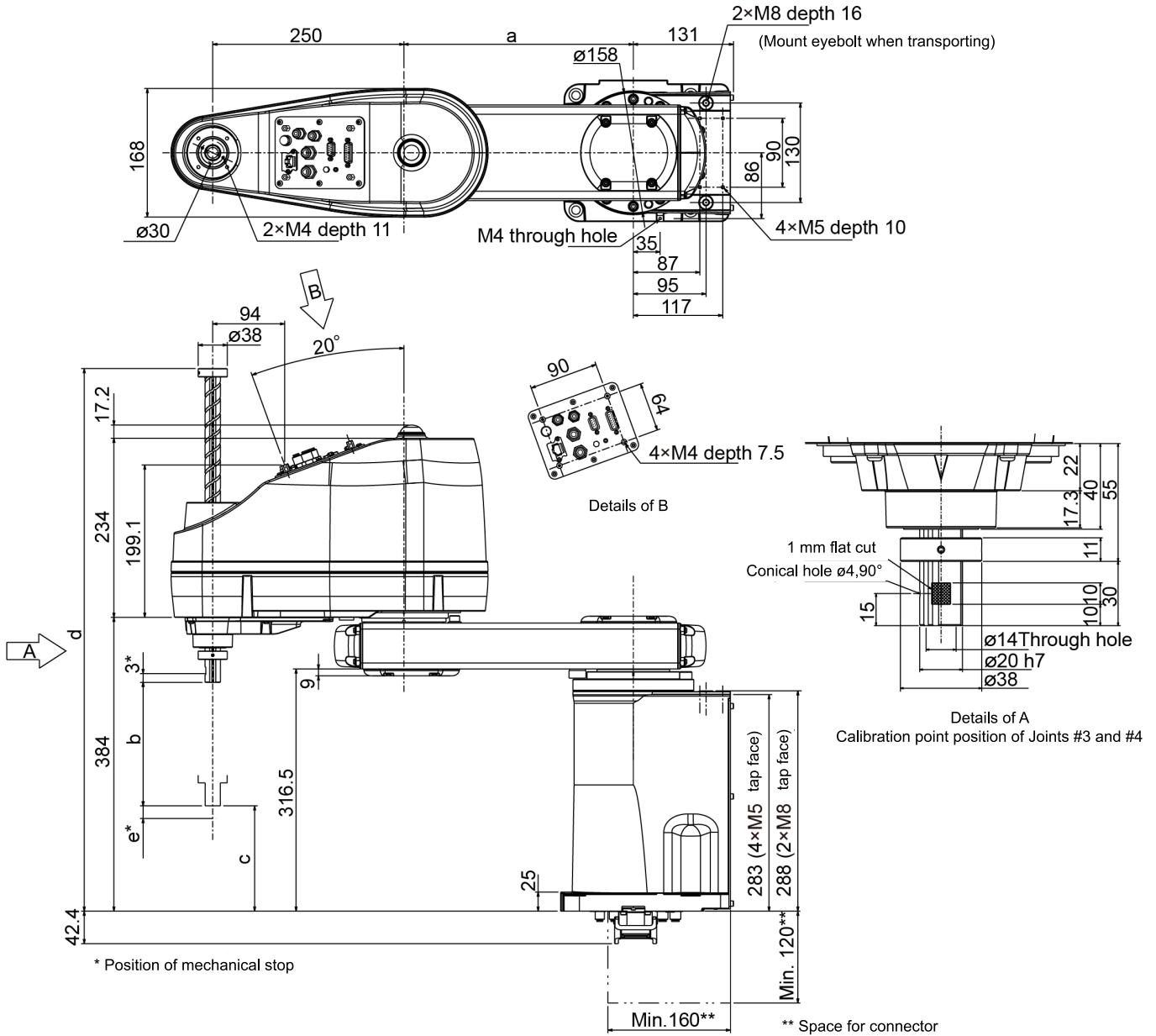

	GX8-A/GX8-B/ GX8-C452SB, EB	GX8-A/GX8-B/ GX8-C453SB, EB	GX8-A/GX8-B/ GX8-C552SB, EB	GX8-A/GX8-B/ GX8-C553SB, EB	GX8-A/GX8-B/ GX8-C652SB, EB	GX8-A/GX8-B/ GX8-C653SB, EB
a	200	200	300	300	400	400
b	200	330	200	330	200	330
c	99	-31	99	-31	99	-31
d	709	834	709	834	709	834
e	15.6	10.6	15.6	10.6	15.6	10.6

ESD specifications GX8-A/GX8-B/GX8-C*EB**

The parts shown below differ from the standard specifications. The external dimensions are identical.

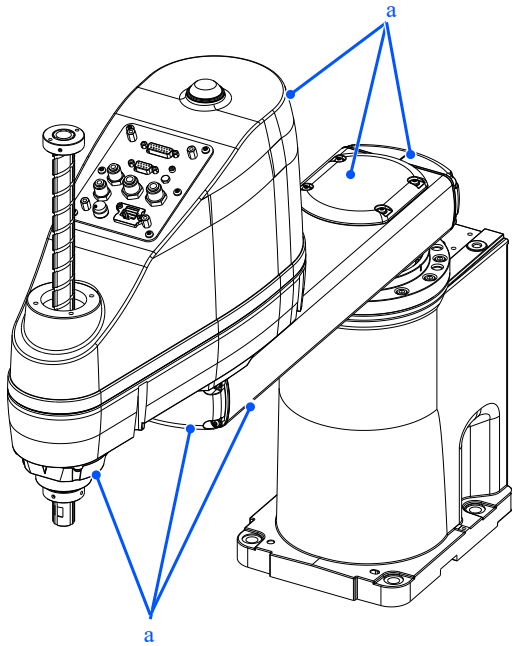

Symbol	Description
a	Plating covers (anti-static specifications)

Cleanroom & ESD specifications GX8-A/GX8-B/GX8-C*CB**

The parts shown below differ from the standard specifications.

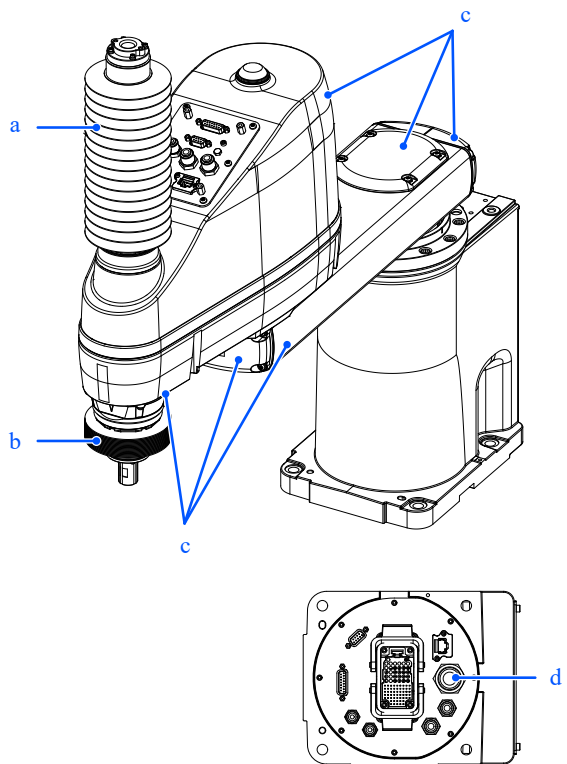

Symbol	Description
a	Upper bellows
b	Lower bellows
c	Plating covers (anti-static specifications)
d	Exhaust port

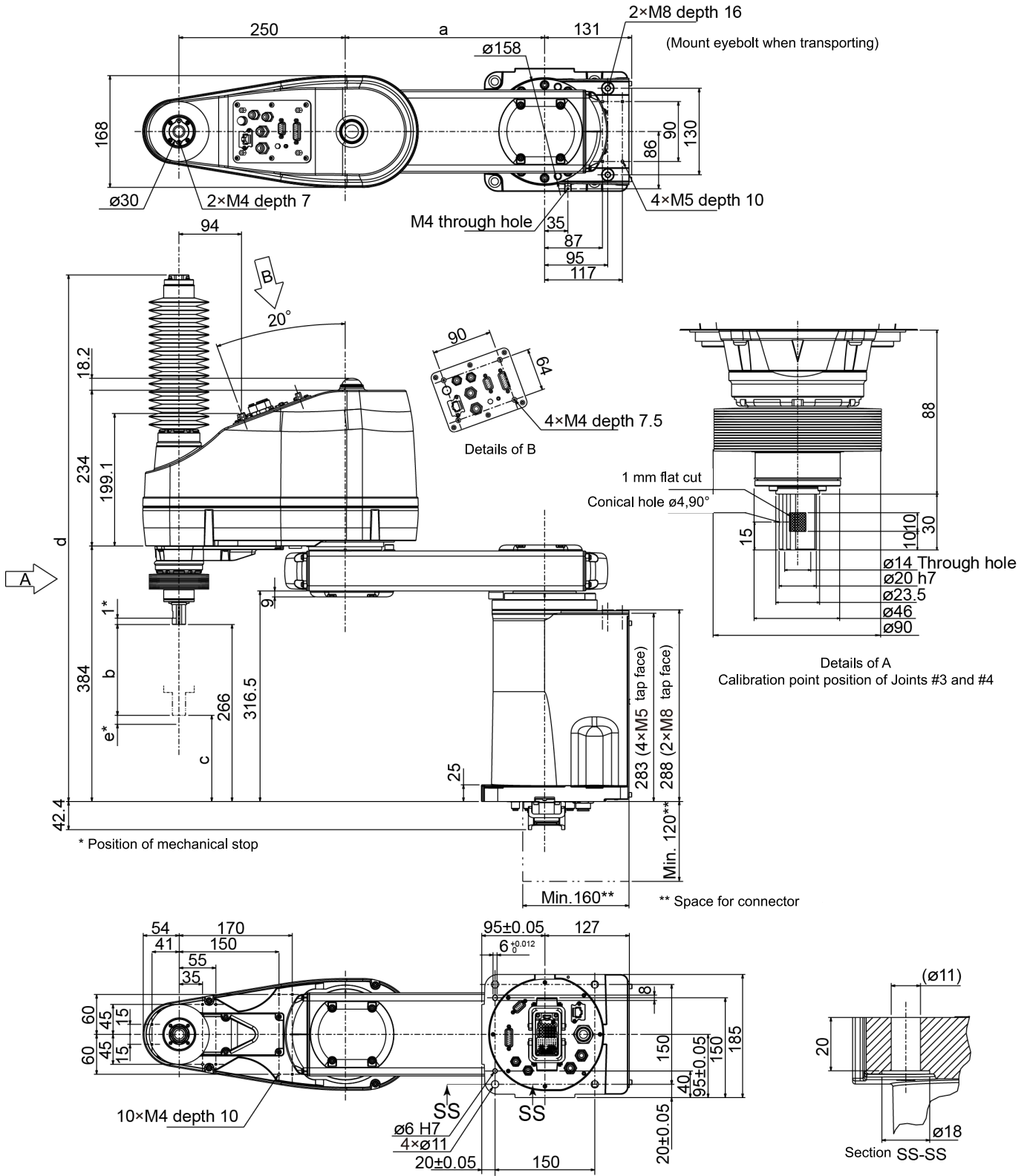

	GX8-A/GX8-B/ GX8-C452CB	GX8-A/GX8-B/ GX8-C453CB	GX8-A/GX8-B/ GX8-C552CB	GX8-A/GX8-B/ GX8-C553CB	GX8-A/GX8-B/ GX8-C652CB	GX8-A/GX8-B/ GX8-C653CB
a	200	200	300	300	400	400
b	170	300	170	300	170	300
c	96	-34	96	-34	96	-34
d	791.5	910.5	791.5	910.5	791.5	910.5
e	12.6	7.6	12.6	7.6	12.6	7.6

Protected-model GX8-A/GX8-B/GX8-C*PB**

The parts shown below differ from the standard specifications.

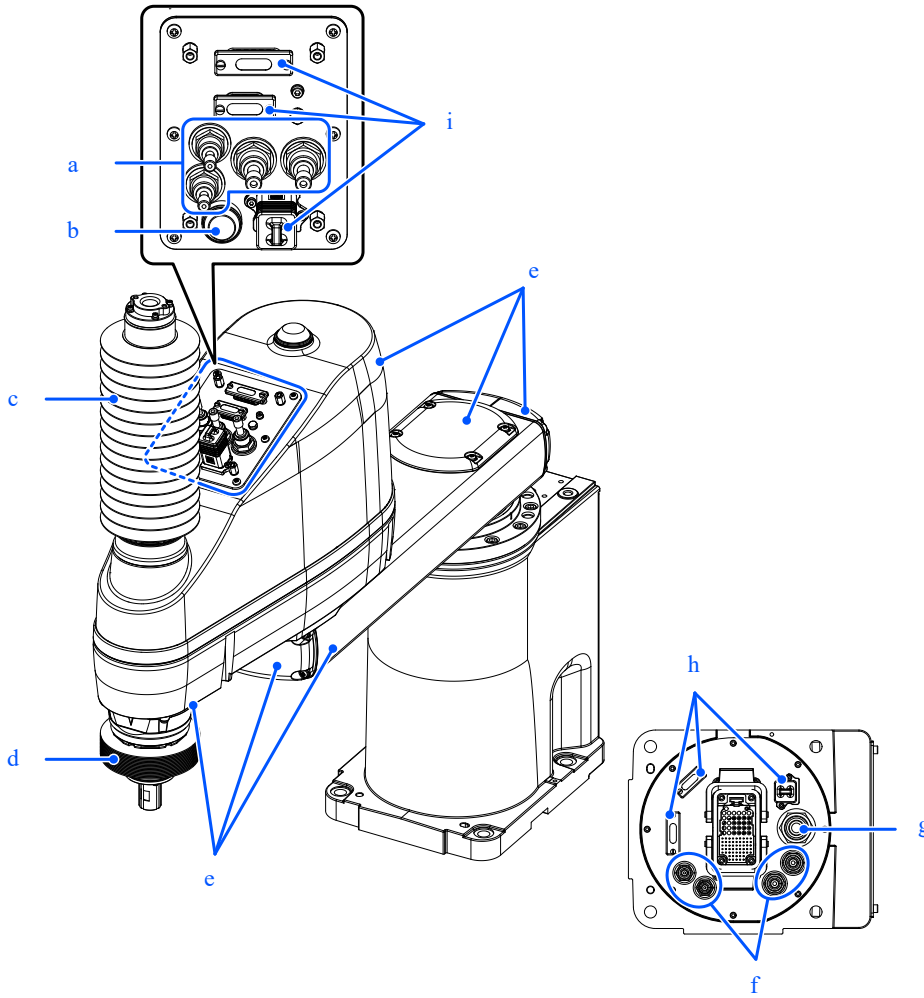

Symbol	Description
a	Fittings with cover (protected-model)
b	Joint #3 and Joint #4 brake release switch (protected-model)
c	Upper bellows
d	Lower bellows
e	Plating cover (oil-resistant specifications)
f	Fittings with cover (protected-model)
g	Exhaust port with cover (protected-model)
h	User connectors with cover (protected-model)
i	User connectors with cover (protected-model)

KEY POINTS

- For protected-models, all screws used for the exterior are stainless steel screws. (except for screws used for stops).
- The part of the M/C cable housing is not IP65 compliant when the M/C cable hood is not connected.

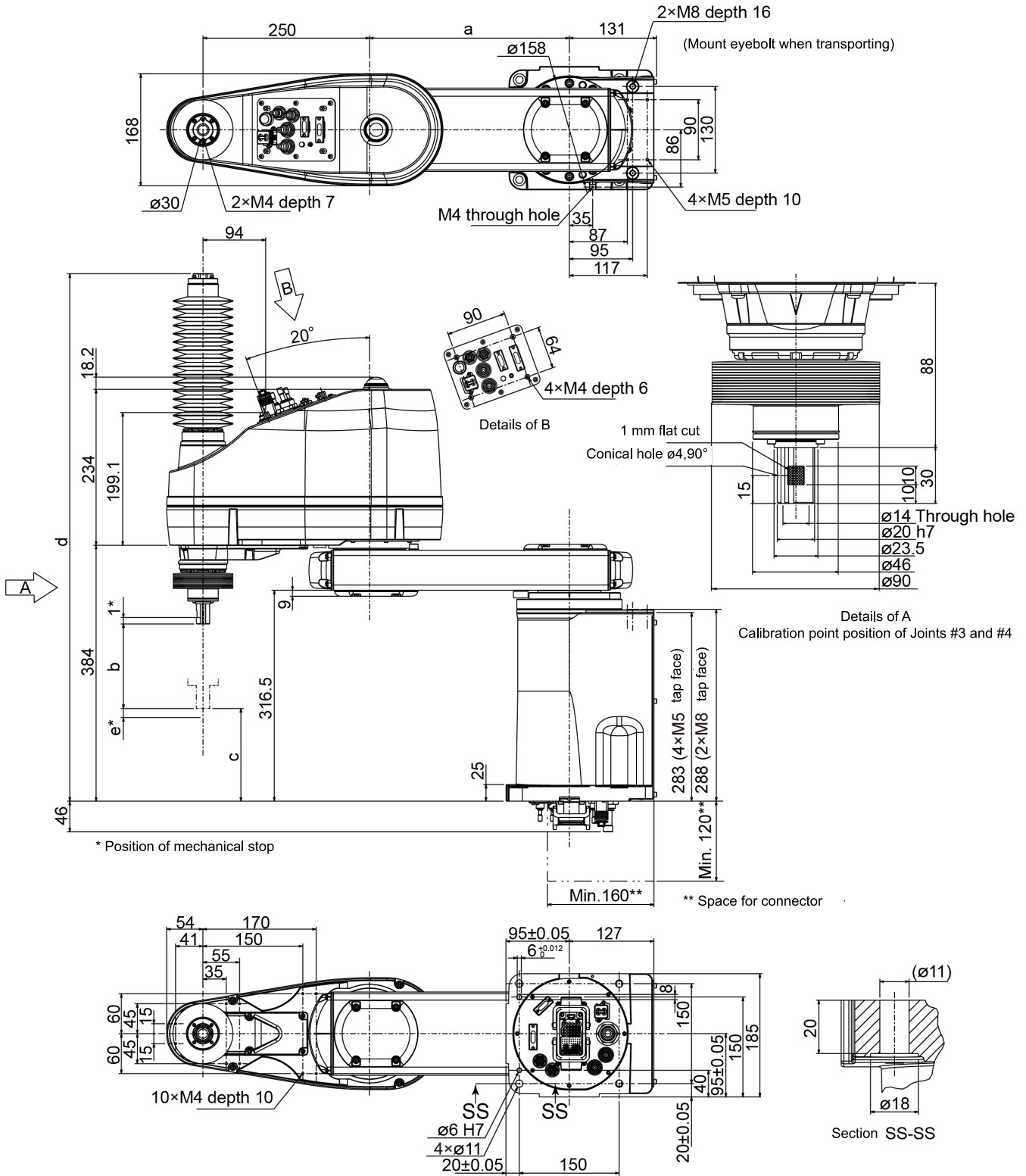

3.2.4.2 Wall Mounting Specifications

Standard specifications GX8-A/GX8-B/GX8-C***SW

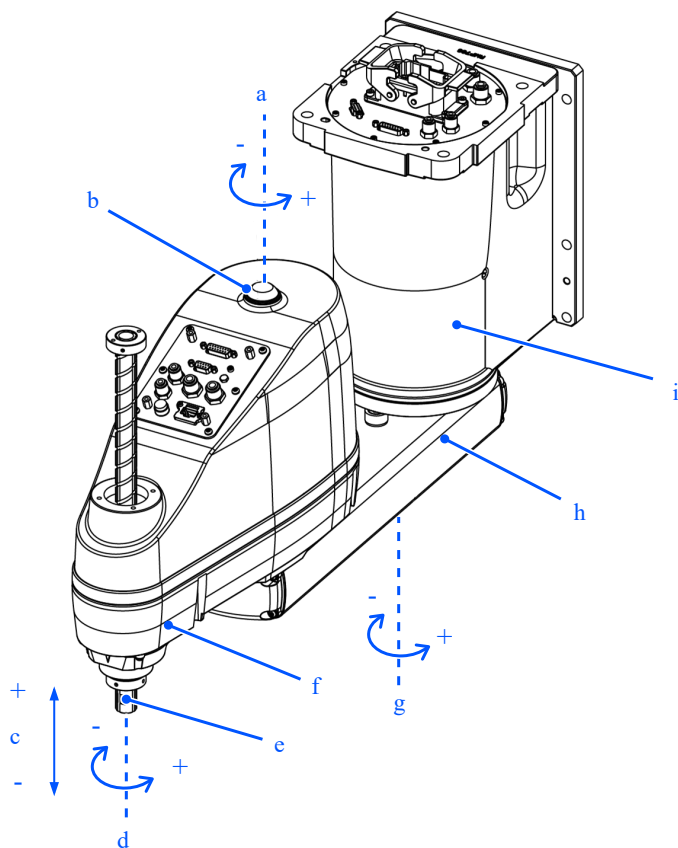

Symbol	Description
a	Joint #2 (rotation)
b	Indicating lamp
c	Joint #3 (up/down movement)
d	Joint #4 (rotation)
e	Shaft
f	Arm #2
g	Joint #1 (rotation)
h	Arm #1
i	Base

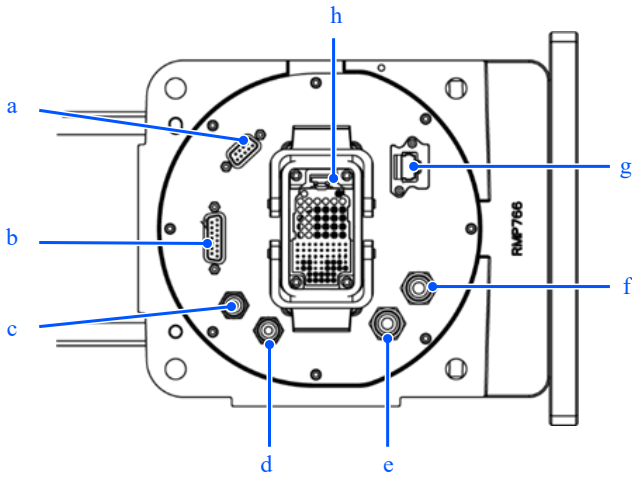

Symbol	Description
a	User connector (9-pin D-sub connector)
b	User connector (15-pin D-sub connector)
c	Fitting for ø4 mm tube (blue)
d	Fitting for ø4 mm tube (white)
e	Fitting for ø6 mm tube (blue)
f	Fitting for ø6 mm tube (white)
g	User connector (Ethernet connector)
h	M/C cable housing

KEY POINTS

- The brake release switch is used with both Joint #3 and Joint #4. Press the brake release switch while in the emergency stop state to simultaneously release the brakes on Joint #3 and Joint #4.
- Before starting any maintenance work, be sure to turn off the Controller and inform others in the surrounding area that work is in progress. Performing any work procedure with the power turned on is extremely dangerous and may result in electric shock and/or malfunction of the robot system.

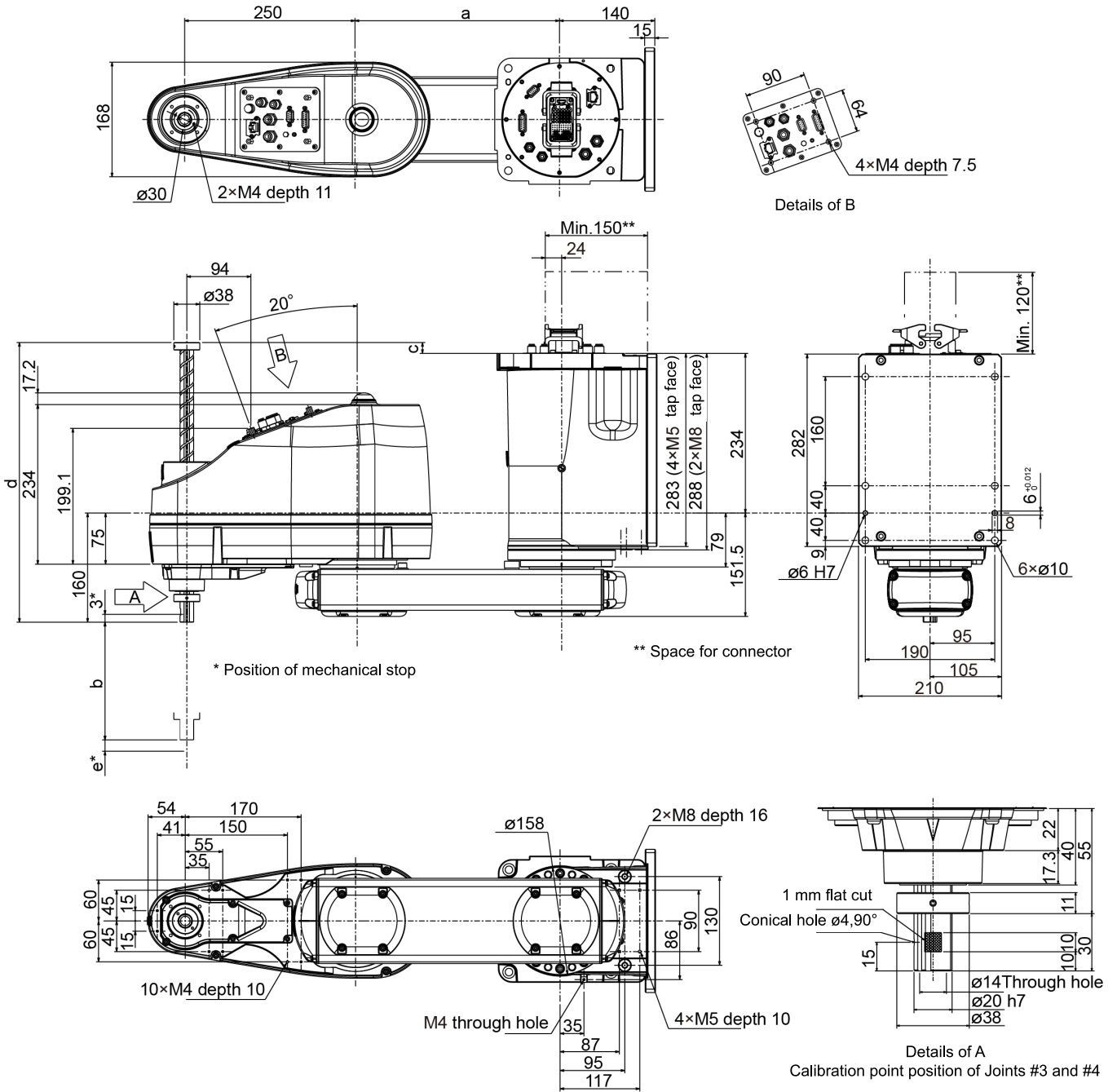

	GX8-A/GX8-B/ GX8-C452SW, EW	GX8-A/GX8-B/ GX8-C453SW, EW	GX8-A/GX8-B/ GX8-C552SW, EW	GX8-A/GX8-B/ GX8-C553SW, EW	GX8-A/GX8-B/ GX8-C652SW, EW	GX8-A/GX8-B/ GX8-C653SW, EW
a	200	200	300	300	400	400
b	200	330	200	330	200	330
c	16	141	16	141	16	141
d	410	535	410	535	410	535
e	15.6	10.6	15.6	10.6	15.6	10.6

ESD specifications GX8-A/GX8-B/GX8-C***EW

The parts shown below differ from the standard specifications. The external dimensions are identical.

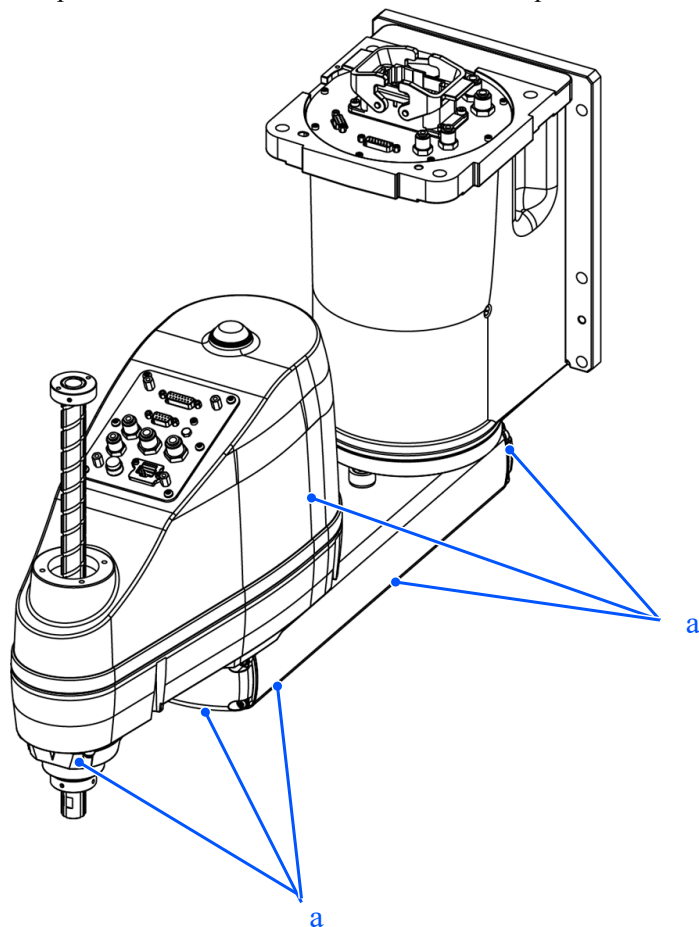

Symbol	Description
a	Plating covers (anti-static specifications)

Cleanroom & ESD specifications GX8-A/GX8-B/GX8-C*CW**

The parts shown below differ from the standard specifications.

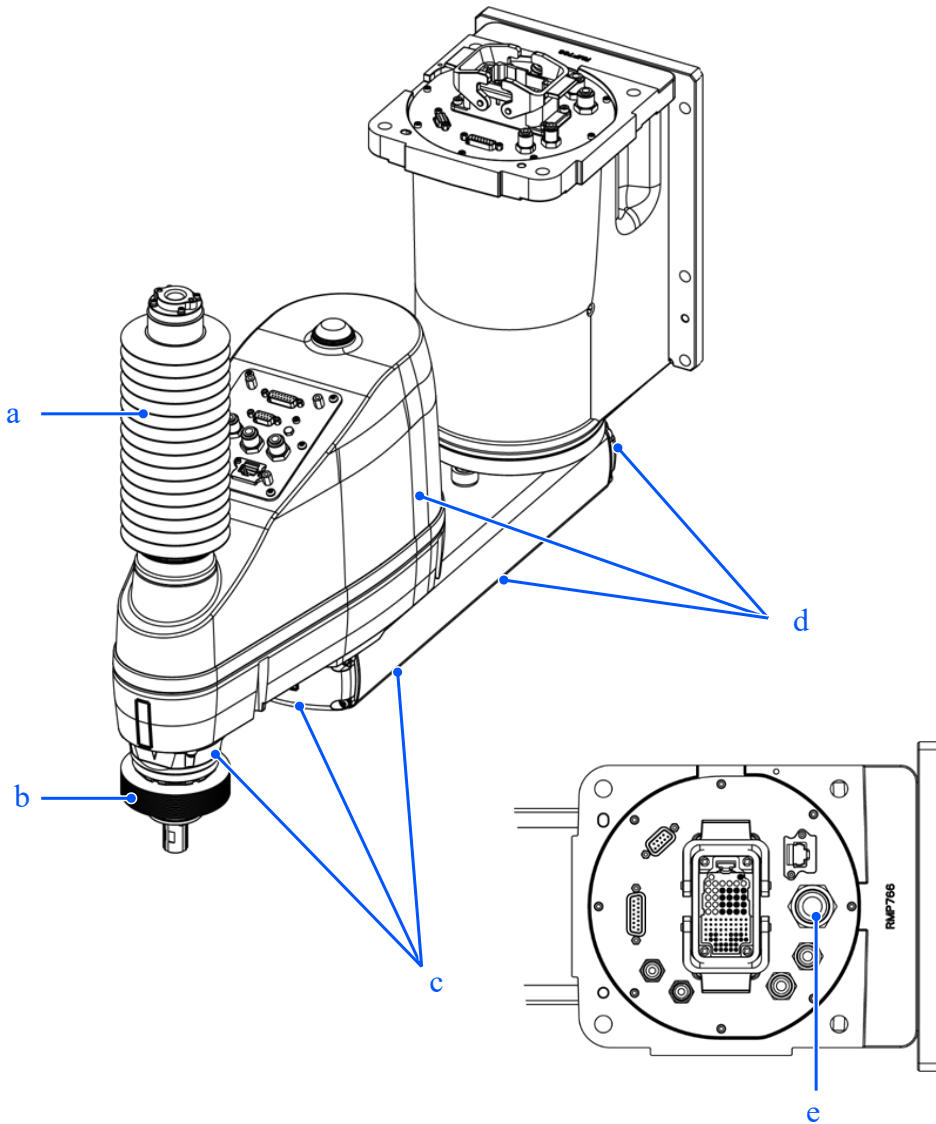

Symbol	Description
a	Upper bellows
b	Lower bellows
c	Plating covers (anti-static specifications)
d	Plating cover (anti-static specifications)
e	Exhaust port

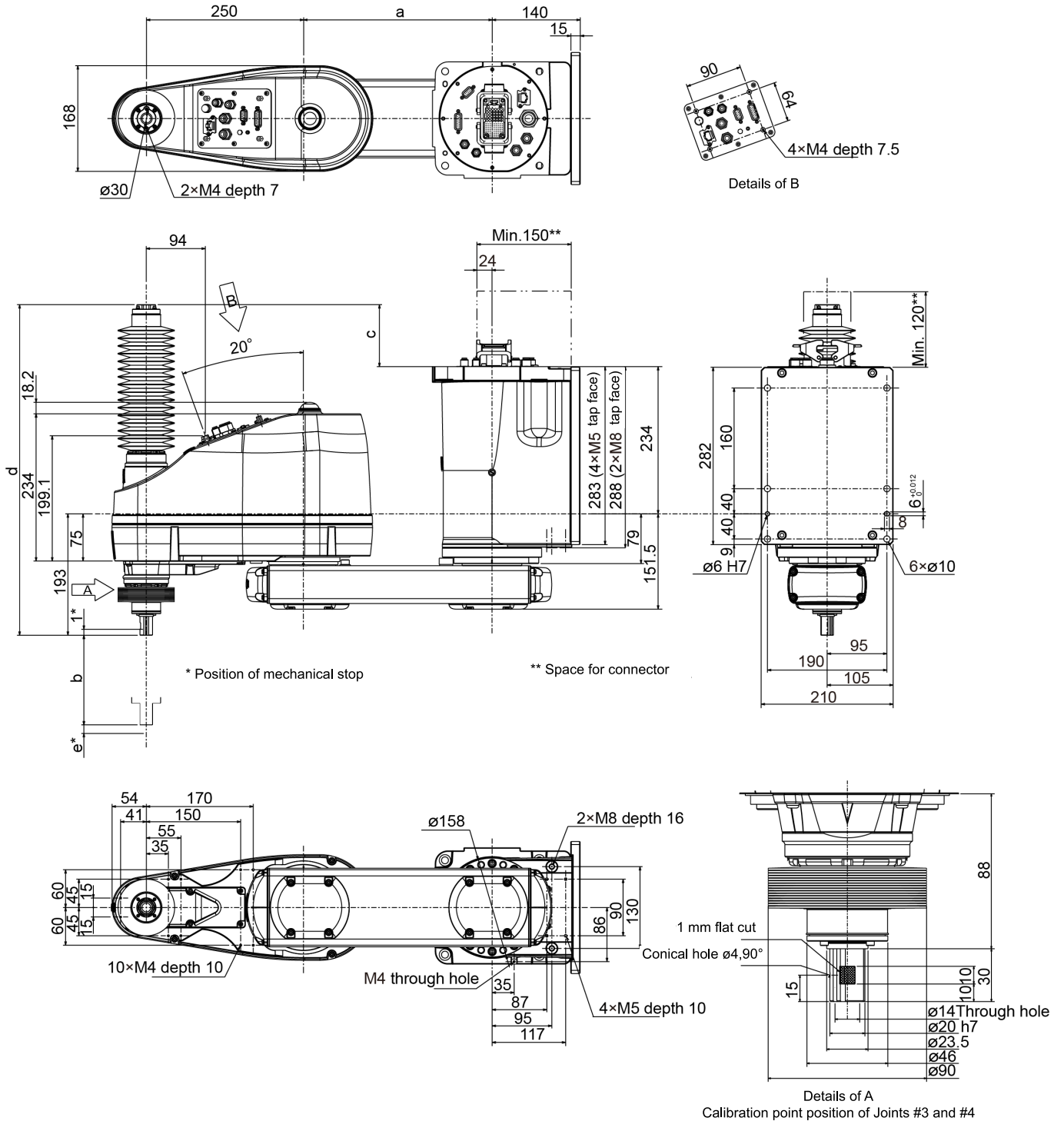

	GX8-A/GX8-B/ GX8-C452CW	GX8-A/GX8-B/ GX8-C453CW	GX8-A/GX8-B/ GX8-C552CW	GX8-A/GX8-B/ GX8-C553CW	GX8-A/GX8-B/ GX8-C652CW	GX8-A/GX8-B/ GX8-C653CW
a	200	200	300	300	400	400
b	170	300	170	300	170	300
c	98.5	223.5	98.5	223.5	98.5	223.5
d	525.5	650.5	525.5	650.5	525.5	650.5
e	12.6	7.6	12.6	7.6	12.6	7.6

Protected-model GX8-A/GX8-B/GX8-C*PW**

The parts shown below differ from the standard specifications.

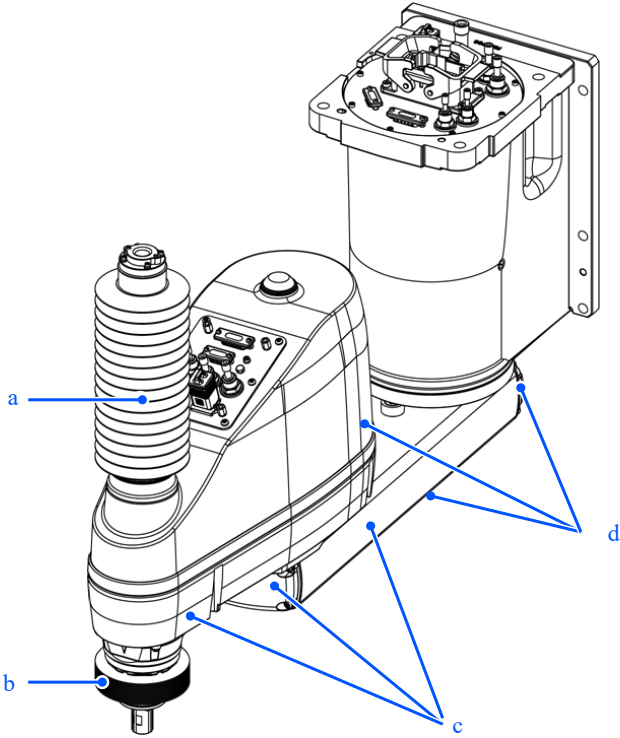

Symbol	Description
a	Upper bellows
b	Lower bellows
c	Plating cover (oil-resistant specifications)
d	Plating cover (oil-resistant specifications)

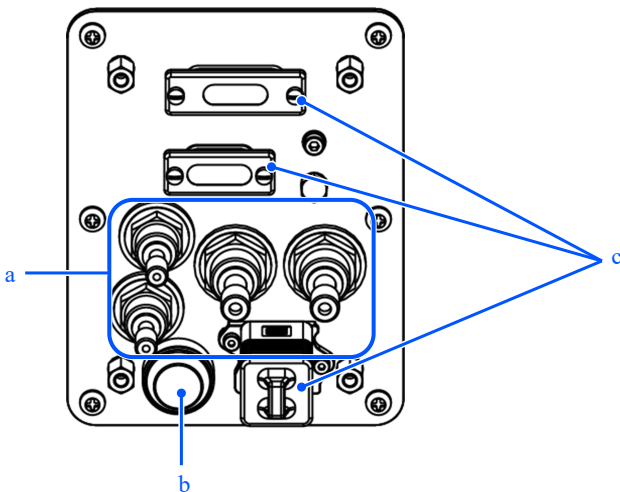

Symbol	Description
a	Fittings with cover (protected-model)
b	Joint #3 and Joint #4 brake release switch (protected-model)
c	User connectors with cover (protected-model)

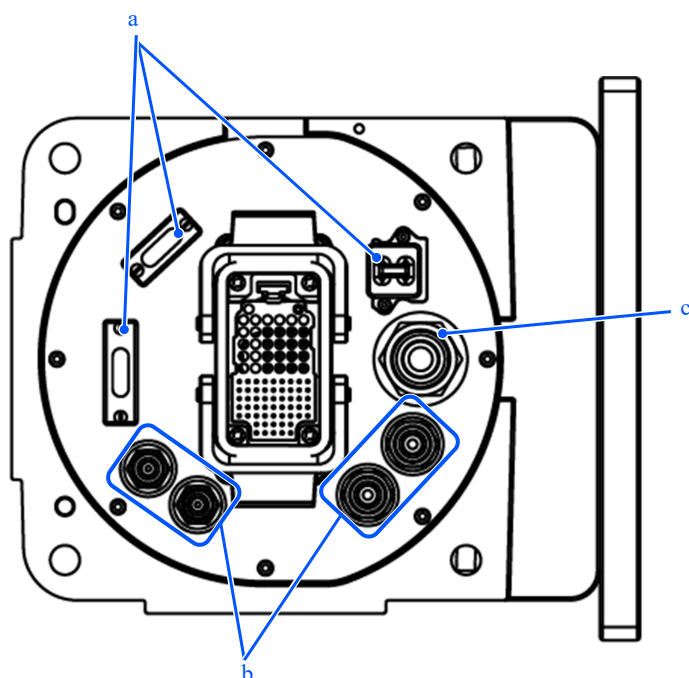

Symbol	Description
a	User connectors with cover (protected-model)
b	Fittings with cover (protected-model)
c	Exhaust port with cover

KEY POINTS

- For protected-models, all screws used for the exterior are stainless steel screws. (except for screws used for stops).
- The part of the M/C cable housing is not IP65 compliant when the M/C cable hood is not connected.

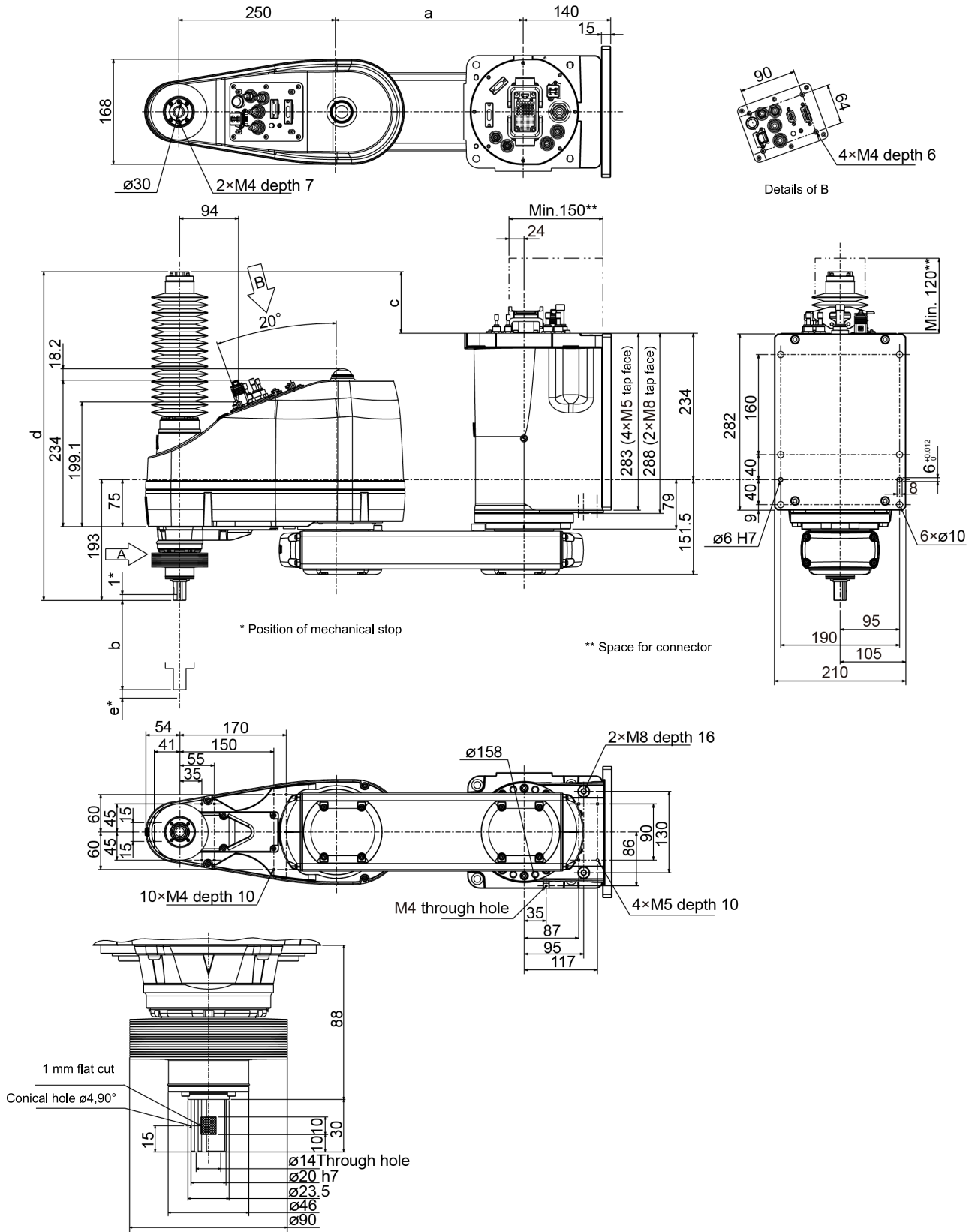

Details of A
Calibration point position of Joints #3 and #4

	GX8-A/GX8-B/ GX8-C452PW	GX8-A/GX8-B/ GX8-C453PW	GX8-A/GX8-B/ GX8-C552PW	GX8-A/GX8-B/ GX8-C553PW	GX8-A/GX8-B/ GX8-C652PW	GX8-A/GX8-B/ GX8-C653PW
a	200	200	300	300	400	400
b	170	300	170	300	170	300
c	98.5	223.5	98.5	223.5	98.5	223.5
d	525.5	650.5	525.5	650.5	525.5	650.5
e	12.6	7.6	12.6	7.6	12.6	7.6

3.2.4.3 Ceiling Mounting Specifications

Standard specifications GX8-A/GX8-B/GX8-C***SR

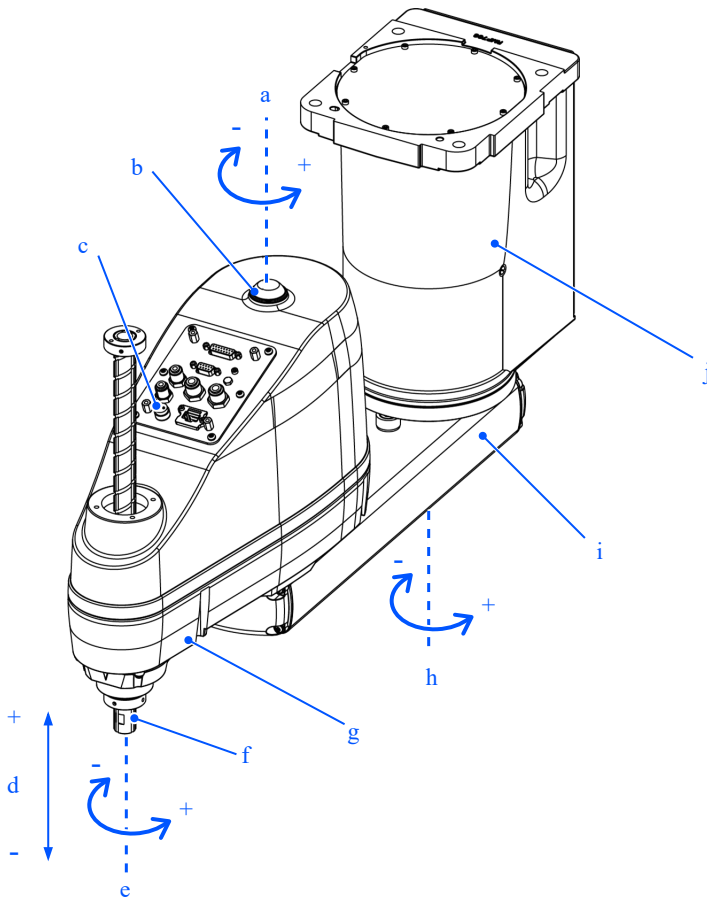

Symbol	Description
a	Joint #2 (rotation)
b	Indicating lamp
c	Joint #3 and Joint #4 brake release switch
d	Joint #3 (up/down movement)
e	Joint #4 (rotation)
f	Shaft
g	Arm #2
h	Joint #1 (rotation)
i	Arm #1
j	Base

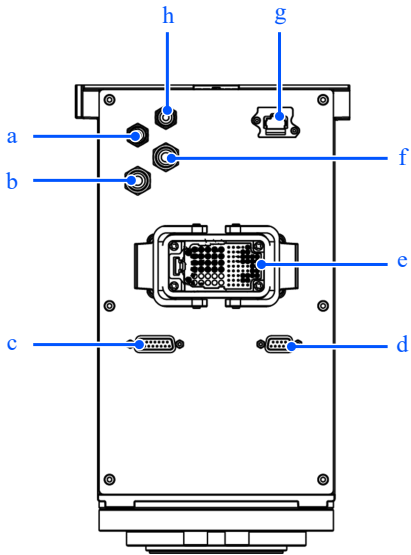

Symbol	Description
a	Fitting for ø4 mm tube (white)
b	Fitting for ø6 mm tube (white)
c	User connector (15-pin D-sub connector)
d	User connector (9-pin D-sub connector)
e	M/C cable housing
f	User connector (Ethernet connector)
g	Fitting for ø6 mm tube (blue)
h	Fitting for ø4 mm tube (blue)

KEY POINTS

- The brake release switch is used with both Joint #3 and Joint #4. Press the brake release switch while in the emergency stop state to simultaneously release the brakes on Joint #3 and Joint #4.
- Before starting any maintenance work, be sure to turn off the Controller and inform others in the surrounding area that work is in progress. Performing any work procedure with the power turned on is extremely dangerous and may result in electric shock and/or malfunction of the robot system.

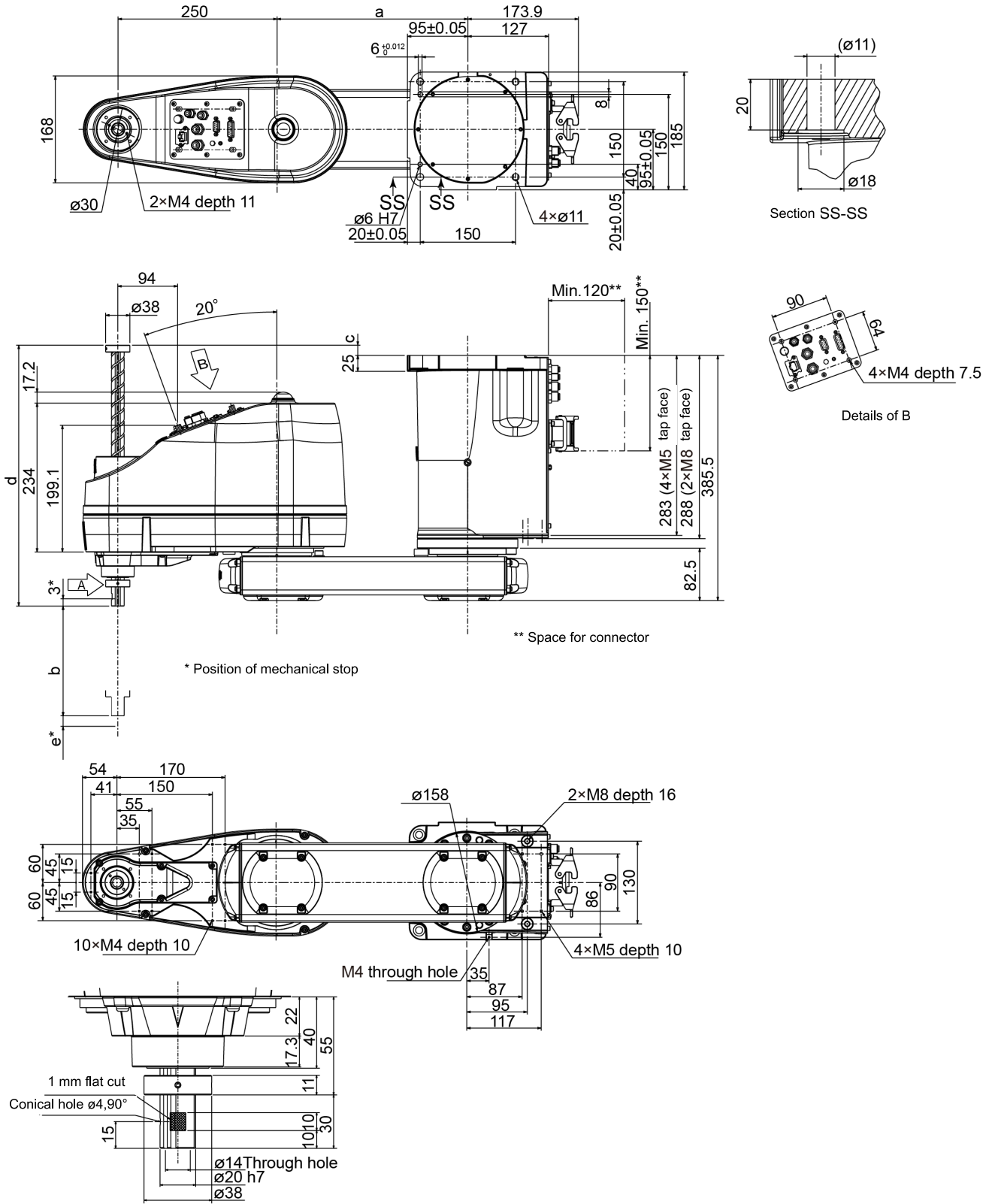

Details of A
Calibration point position of Joints #3 and #4

	GX8-A/GX8-B/ GX8-C452SR, ER	GX8-A/GX8-B/ GX8-C453SR, ER	GX8-A/GX8-B/ GX8-C552SR, ER	GX8-A/GX8-B/ GX8-C553SR, ER	GX8-A/GX8-B/ GX8-C652SR, ER	GX8-A/GX8-B/ GX8-C653SR, ER
a	200	200	300	300	400	400
b	200	330	200	330	200	330
c	16	141	16	141	16	141
d	410	535	410	535	410	535
e	15.6	10.6	15.6	10.6	15.6	10.6

ESD specifications GX8-A/GX8-B/GX8-C*ER**

The parts shown below differ from the standard specifications. The external dimensions are identical.

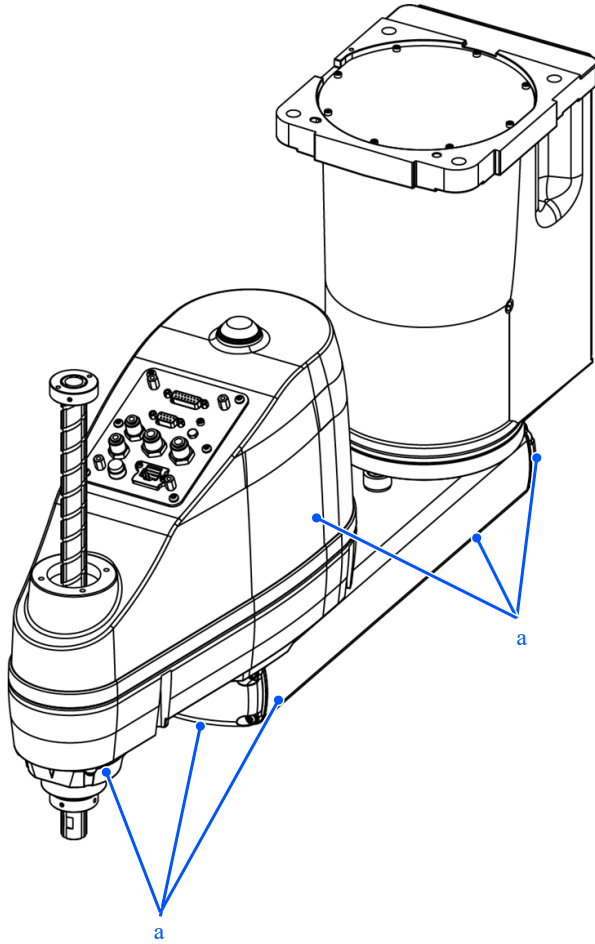

Symbol	Description
a	Plating covers (anti-static specifications)

Cleanroom & ESD specifications GX8-A/GX8-B/GX8-C*CR**

The parts shown below differ from the standard specifications.

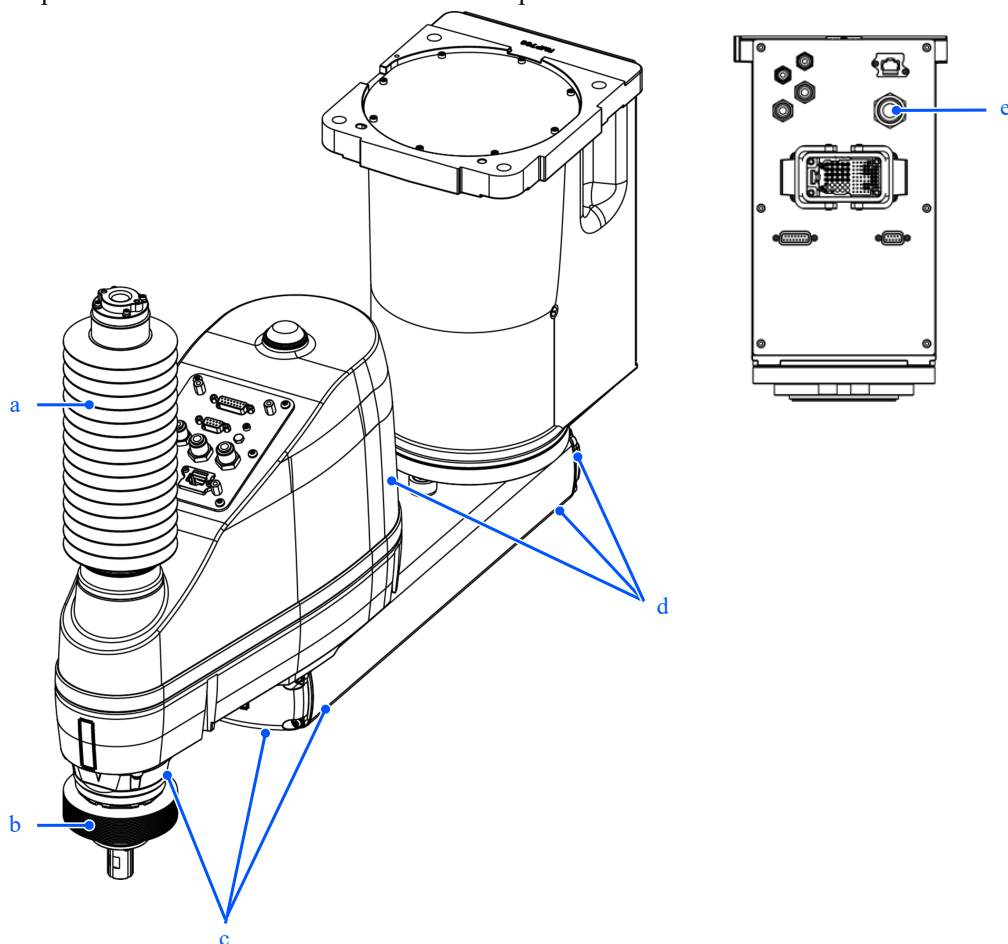

Symbol	Description
a	Upper bellows
b	Lower bellows
c	Plating covers (anti-static specifications)
d	Plating covers (anti-static specifications)
e	Exhaust port

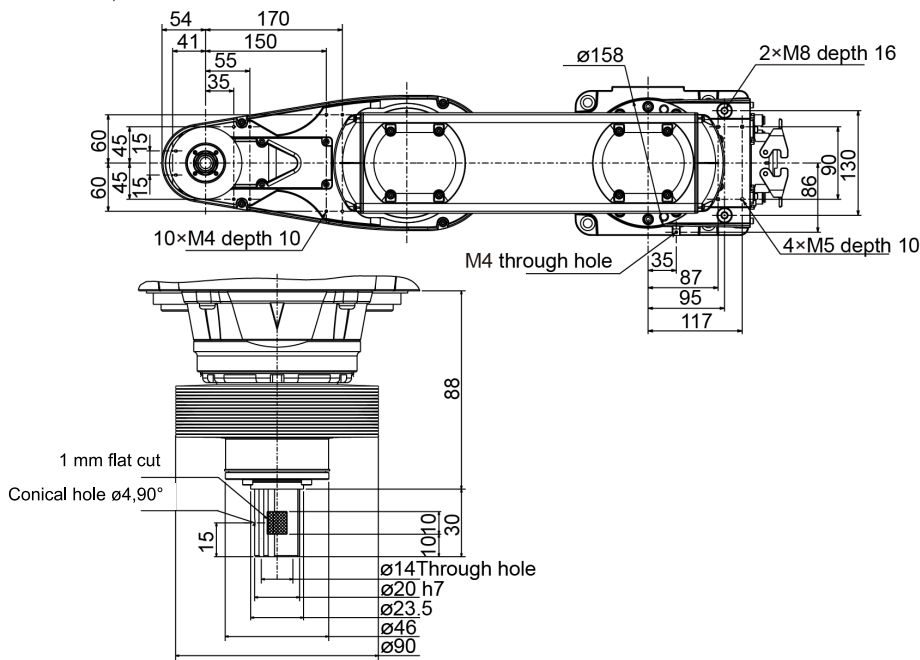
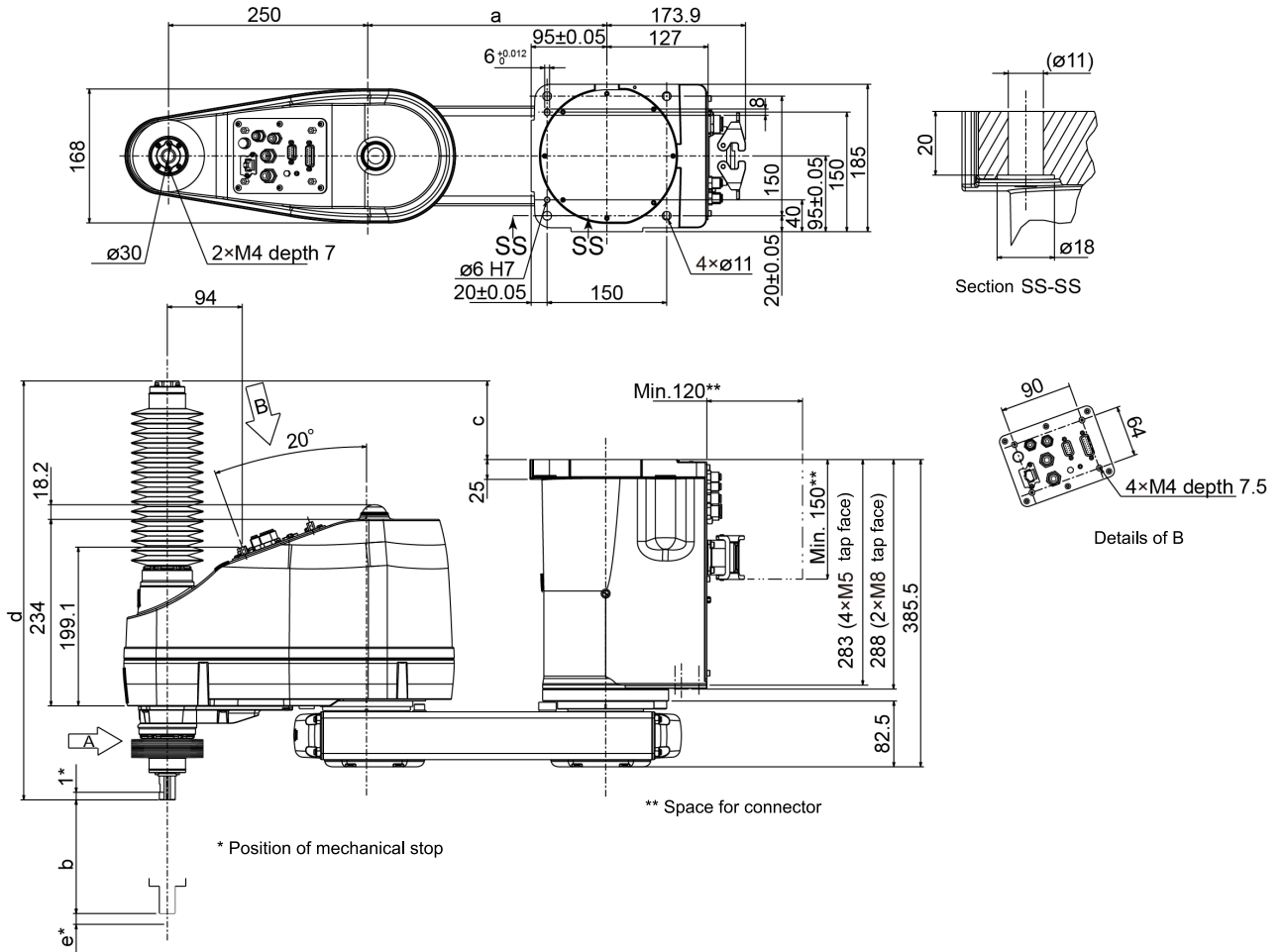

Details of A
Calibration point position of Joints #3 and #4

	GX8-A/GX8-B/ GX8-C452CR	GX8-A/GX8-B/ GX8-C453CR	GX8-A/GX8-B/ GX8-C552CR	GX8-A/GX8-B/ GX8-C553CR	GX8-A/GX8-B/ GX8-C652CR	GX8-A/GX8-B/ GX8-C653CR
a	200	200	300	300	400	400
b	170	300	170	300	170	300
c	98.5	223.5	98.5	223.5	98.5	223.5
d	525.5	650.5	525.5	650.5	525.5	650.5
e	12.6	7.6	12.6	7.6	12.6	7.6

Protected-model GX8-A/GX8-B/GX8-C*PR**

The parts shown below differ from the standard specifications.

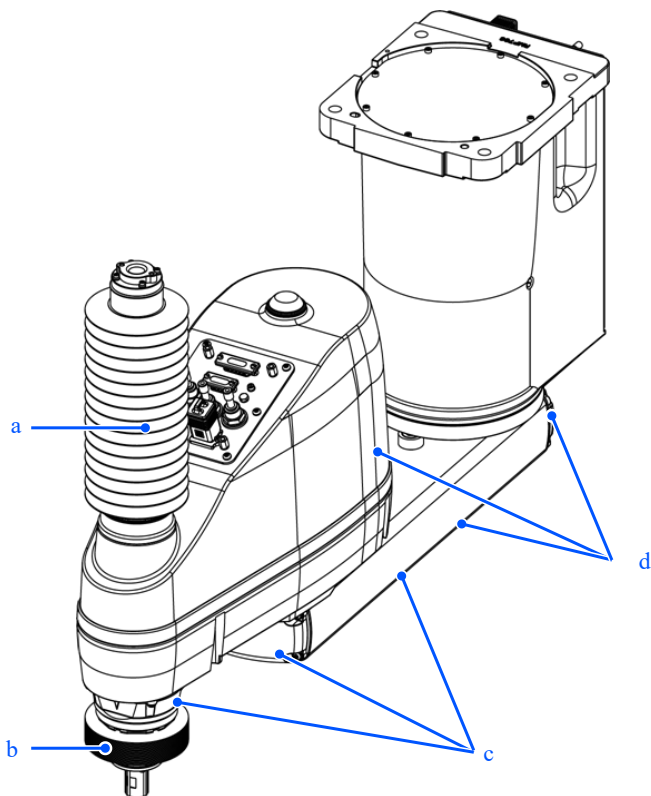

Symbol	Description
a	Upper bellows
b	Lower bellows
c	Plating cover (oil-resistant specifications)
d	Plating cover (oil-resistant specifications)

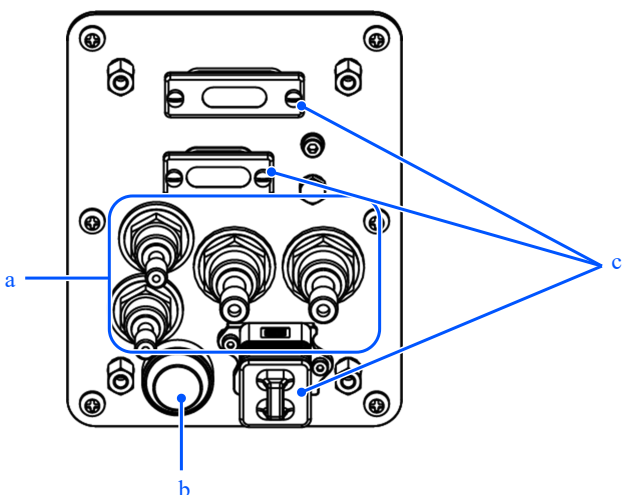

Symbol	Description
a	Fittings with cover (protected-model)
b	Joint #3 and Joint #4 brake release switch (protected-model)

Symbol	Description
c	User connectors with cover (protected-model)

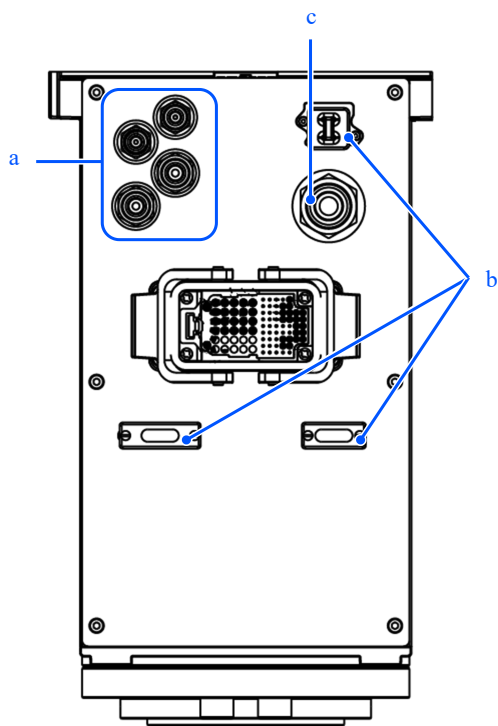

Symbol	Description
a	Fittings with cover (protected-model)
b	User connectors with cover (protected-model)
c	Exhaust port with cover

KEY POINTS

- For protected-models, all screws used for the exterior are stainless steel screws. (except for screws used for stops).
- The part of the M/C cable housing is not IP65 compliant when the M/C cable hood is not connected.

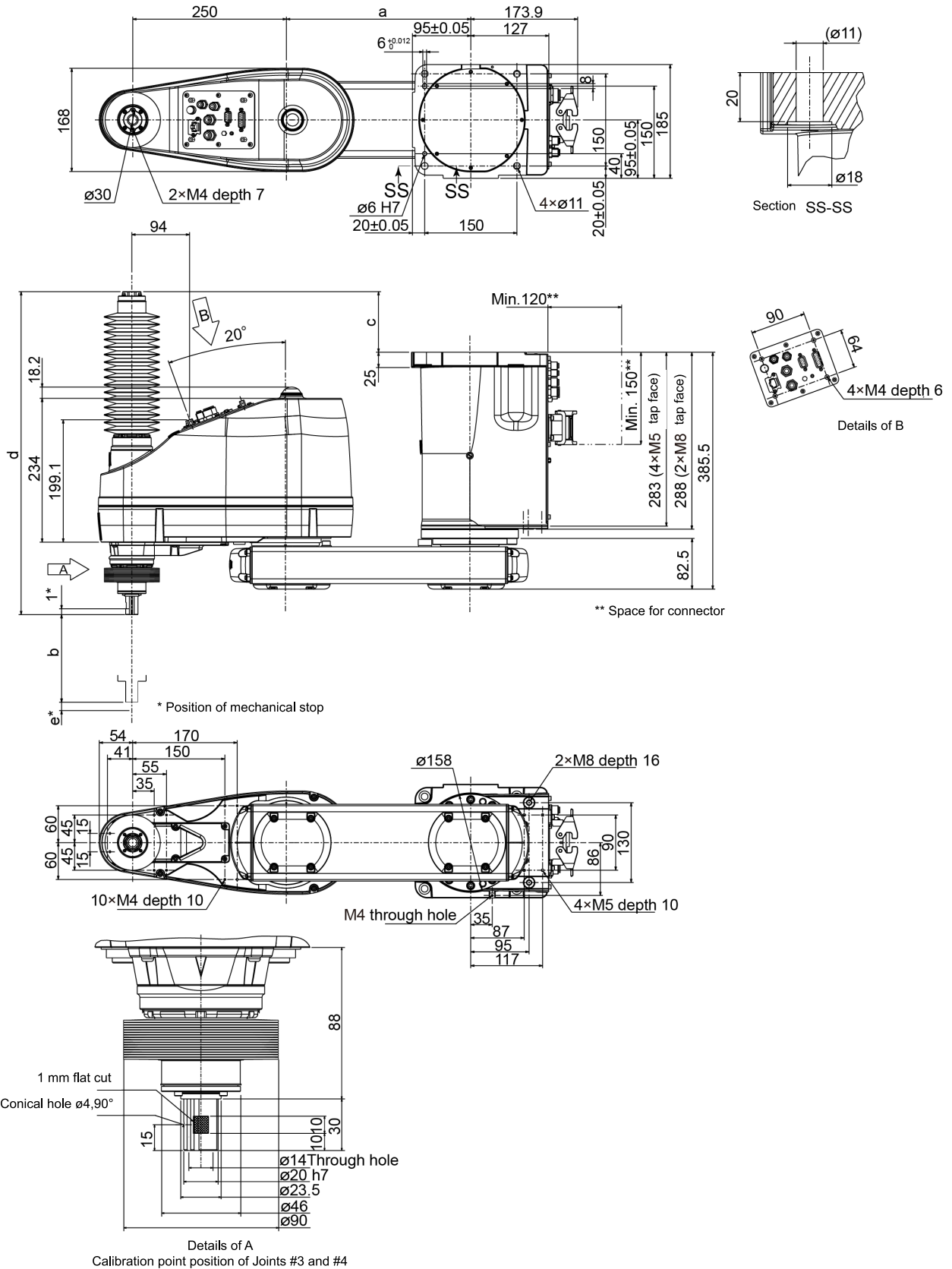

Details of A
 Calibration point position of Joints #3 and #4

	GX8-A/GX8-B/ GX8-C452PR	GX8-A/GX8-B/ GX8-C453PR	GX8-A/GX8-B/ GX8-C552PR	GX8-A/GX8-B/ GX8-C553PR	GX8-A/GX8-B/ GX8-C652PR	GX8-A/GX8-B/ GX8-C653PR
a	200	200	300	300	400	400
b	170	300	170	300	170	300
c	98.5	223.5	98.5	223.5	98.5	223.5
d	525.5	650.5	525.5	650.5	525.5	650.5
e	12.6	7.6	12.6	7.6	12.6	7.6

3.2.5 Specifications Table

For the specifications tables of each model, refer to the following section.

[Appendix A: Specifications Table](#)

3.2.6 How to Set the Model

The Manipulator model for your system has been set before shipment from the factory. Normally, the model does not need to be changed when you receive your system.

 **CAUTION**

- If changing the setting of the Manipulator model, be responsible and absolutely certain that the wrong Manipulator model is not set. Incorrect setting of the Manipulator model may result in abnormal or no operation by the Manipulator and could even cause safety problems.

 **KEY POINTS**

If a custom specifications number (MT^{***}) or (X^{***}) is written on the face plate (serial number label), the Manipulator has custom specifications.

Models with custom specifications may require a different setting procedure. Check the custom specifications number and contact the supplier for more information.

The Manipulator model is set from software. For details, refer to the following manual. "Epson RC+ User's Guide - Robot Settings"

3.3 Environment and Installation

The robot system should be designed and installed by people who have received installation training provided by Epson and the suppliers. Also, the laws and regulations of the installation country must be followed.

3.3.1 Environment

To ensure that the robot system operates and maintains maximum performance and to ensure its safe use, the Manipulator should be installed in an environment that meets the following requirements.

Item	Requirement
Ambient temperature *1	Installation: 5 to 40°C Transport, storage: -20 to 60°C
Ambient relative humidity	Installation: 10 to 80% (no condensation) Transport, storage: 10 to 90% (no condensation)
Fast transient burst noise	1 kV or less (signal line)
Electrostatic noise	4 kV or less
Altitude	2,000 m or less

 **KEY POINTS**

*1 The ambient temperature requirement is for the Manipulator only. For details on the environment requirements for the connected Controller, refer to the following manual.

"Controller Manual"

 **KEY POINTS**

When used in a low-temperature environment near the minimum temperature specified in the product specifications, or when the unit is idle for a long period of time during holidays or at night, a collision detection error or similar error may occur immediately after the start of operation due to high resistance in the drive unit. In such cases, warm-up operation for about 10 minutes is recommended.

 **KEY POINTS**

If there are conductive objects such as fences or ladders within 2.5 m of the Manipulator, these objects must be grounded.

Also, depending on the environmental specifications of the Manipulator, the following requirements must be met.

Environmental Specifications	Manipulator Installation Environment Requirements
S, E, C, P	<ul style="list-style-type: none"> ▪ Install indoors. ▪ Keep away from direct sunlight. ▪ Keep away from shocks or vibrations. ▪ Keep away from sources of electric noise. ▪ Keep away from explosive areas. ▪ Keep away from large quantities of radiation.
S, E, C	<ul style="list-style-type: none"> ▪ Keep away from dust, oily smoke, salinity, metal powder, and other contaminants. ▪ Keep away from flammable or corrosive liquids and gases. ▪ Keep away from water.

The following items should also be taken into consideration for the installation environment of Manipulators with protected-models.

- These are compliant with the IP65 protection class (IEC 60529, JIS C0920). They can be installed in environments exposed to dust or splashing of water.
- They can be installed in environments where dust, oil smoke, metal powder, and similar substances are airborne, but they are not suitable for use with nitrile rubber oil seals, O-rings, packings, liquid gaskets, or other substances that impair sealing performance.
- The Manipulator cannot be used in environments exposed to liquids or airborne droplets that are corrosive such as acids or alkalis.
- In environments that are exposed to airborne droplets containing salt, rust may also form on the Manipulator.
- Manipulator surfaces are generally oil-resistant, but if special oils are to be used, oil resistance should be checked before use. For more information, please contact the supplier.
- In environments with rapid changes in temperature and humidity, condensation may form inside the Manipulator.

- When handling food directly, it is necessary to make sure that the Manipulator is not likely to contaminate the food. For more information, please contact the supplier.
- The Controllers used with Manipulators with protected-models do not have protection against harsh environments. The Controller should be installed in a location that meets its operating environment requirements.

WARNING

Always use a circuit breaker for the Controller's power supply. Failure to use a circuit breaker may result in an electrical shock hazard or malfunction due to an electrical leakage.

Select the correct circuit breaker based on the Controller that you are using. For details, refer to the following manual.

"Controller Manual"

CAUTION

- When cleaning the Manipulator, do not rub it strongly with alcohol or benzene. Coated surfaces may lose their luster.

3.3.2 Base Table

A base table for anchoring the Manipulator is not supplied. The base table must be fabricated or obtained by the customer. The shape and size of the base table vary depending on the application of the robot system. As a reference when designing the base table, the requirements from the Manipulator side are shown here.

The base table must not only be able to bear the weight of the Manipulator but also be able to withstand the dynamic movement of the Manipulator when it operates at maximum acceleration/deceleration. Ensure that the base table has enough strength by using reinforcing materials such as crossbeams.

The torque and reaction force produced by the movement of the Manipulator are as follows:

- Maximum torque on horizontal surface: 700 N·m
- Maximum reaction force in horizontal direction: 4,000 N
- Maximum reaction force in vertical direction: 1,500 N

For models with table top mounting specifications and models with ceiling mounting specifications, the threaded holes required for mounting the Manipulator base are M8 or M10.

For models with wall mounting specifications, the threaded holes required for mounting the Manipulator base are M8. Use bolts for mounting the Manipulator that have a strength compliant with ISO 898-1 property class 10.9 or 12.9. The dimensions are provided in the following sections.

Names of Parts and Their Dimensions

Manipulator Mounting Dimensions

The plate for the Manipulator mounting face should be at least 20 mm thick and made of steel for reducing vibrations. A surface roughness of 25 μm or less at the maximum height is appropriate.

The base table must be secured to the floor or wall to prevent it from moving.

The Manipulator mounting surface should have a flatness of 0.5 mm or less and an inclination of 0.5° or less to a horizontal or vertical surface. If the installation surface does not have the proper flatness, the base of the Manipulator may be damaged or the robot may be unable to operate at maximum performance.

When using a leveler to adjust the height of the base table, use a screw with M16 diameter or more.

If passing cables through the holes in the base table, refer to the connector dimensions in the figures below.

(Units: mm)

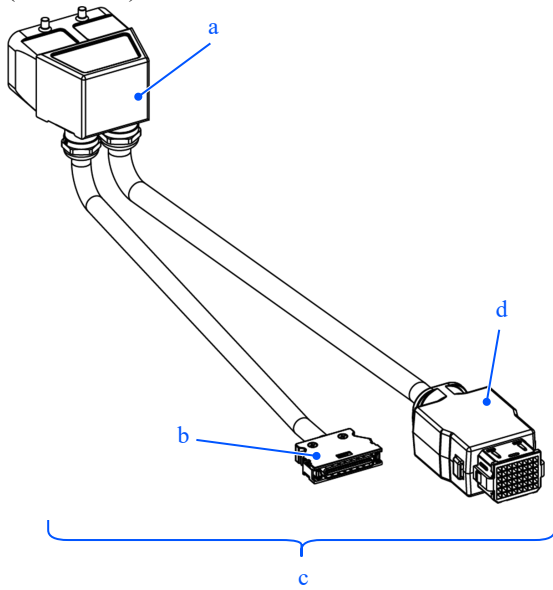

Symbol	Description
a	M/C cable hood
b	Signal connector
c	M/C cable
d	Power connector

Signal Connector	Power Connector (Straight)	Power Connector (L-shaped)

For details on the environmental requirements for the space when housing the Controller in the base table, refer to the following manual.

"Controller Manual"

⚠ WARNING

To ensure safety, be sure to install safety barriers for the robot system. For more information on safeguards, refer to the following section.

Safeguard (SG)

By drilling holes in the base table in advance, the Joint #1 motor can be replaced while the Manipulator is fixed to the base table for improved ease of maintenance.

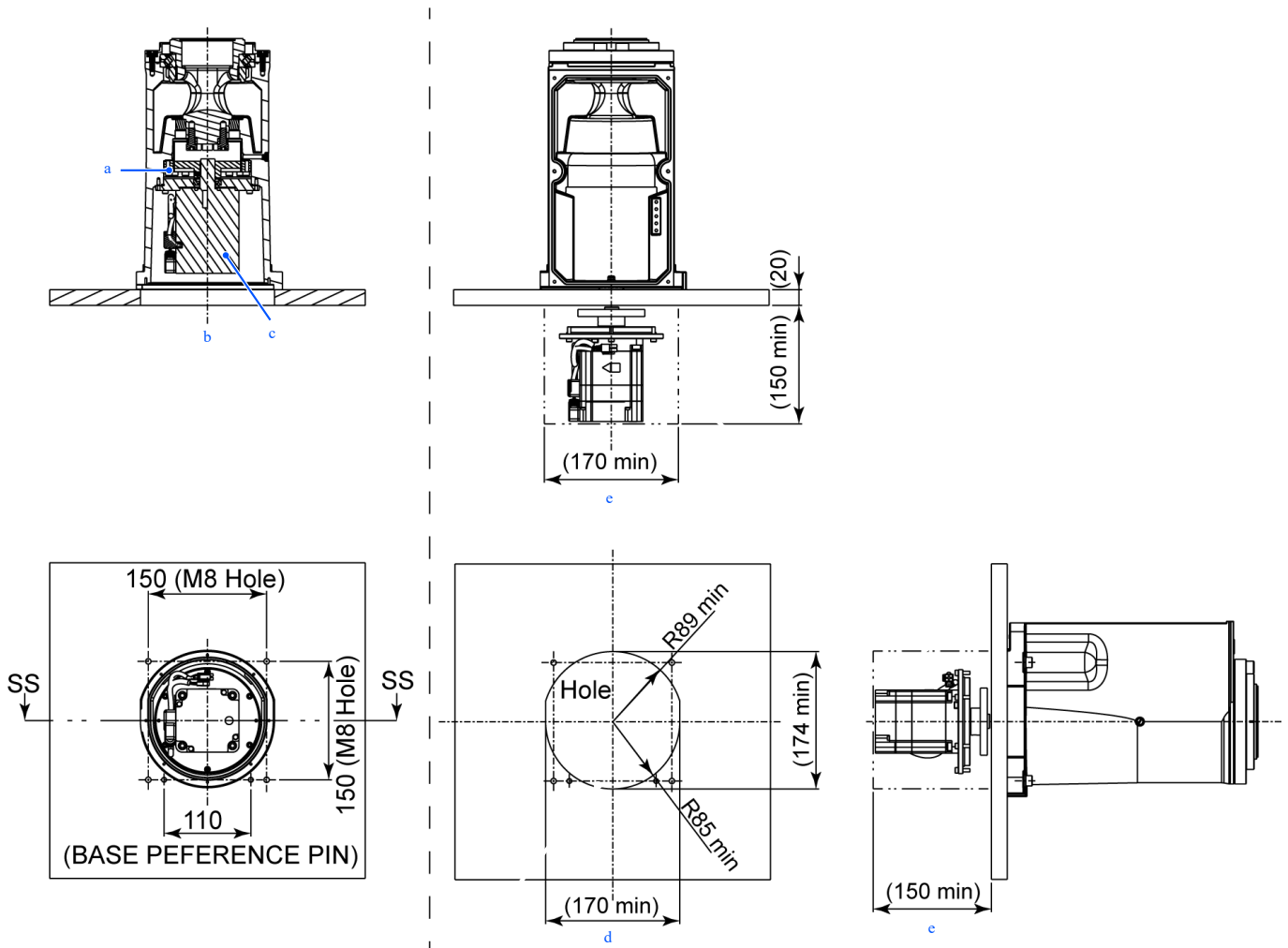

Symbol	Description
a	Joint #1 reduction gear
b	Cross-sectional view along SS-SS
c	Joint #1 motor
d	Minimum hole on the base table required to remove the Joint #1 motor and reduction gear
e	Minimum space on the base table required to remove the Joint #1 motor and reduction gear

3.3.3 Manipulator Mounting Dimensions

The maximum envelope of the Manipulator is shown in the figures below. The maximum envelope shown in each figure shows the case when the radius of the hand is 60 mm or less. If the radius of the hand exceeds 60 mm, define the radius as the distance to the outer edge of the maximum envelope. In addition to the hand, if a camera, solenoid valve, or other component attached to the arm is large, set the maximum envelope to include the range that the component may reach.

Also, besides the area required for installation of the Manipulator, Controller, peripheral equipment, and other devices, the following space should be provided at a minimum.

- Space for teaching
- Space for maintenance and inspection (Space for working safely in the safety barriers)

- Space for cables

KEY POINTS

- When installing the cables, be sure to maintain sufficient distance from obstacles.
- For the minimum bend radius of the M/C cable, refer to the following section.

GX8

- Also, leave enough space for other cables so that they are not forced to bend at extreme angles.

WARNING

Install the Manipulator in a location with enough space so that a tool or a workpiece tip does not reach a wall or safety barriers when the Manipulator extends its arm while holding a workpiece. If the tool or the workpiece tip reaches a wall or safety barriers, it is extremely hazardous and may result in serious bodily injury to operators and/or severe equipment damage.

The distance between the safety barriers and the tool or workpiece should be set according to ISO 10218-2.

For the stopping time and stopping distance, refer to the following sections.

[Appendix B: Stopping Time and Stopping Distance at Emergency Stop](#)

[Appendix C: Stopping Time and Stopping Distance When Safeguard is Open](#)

Table top mounting specifications

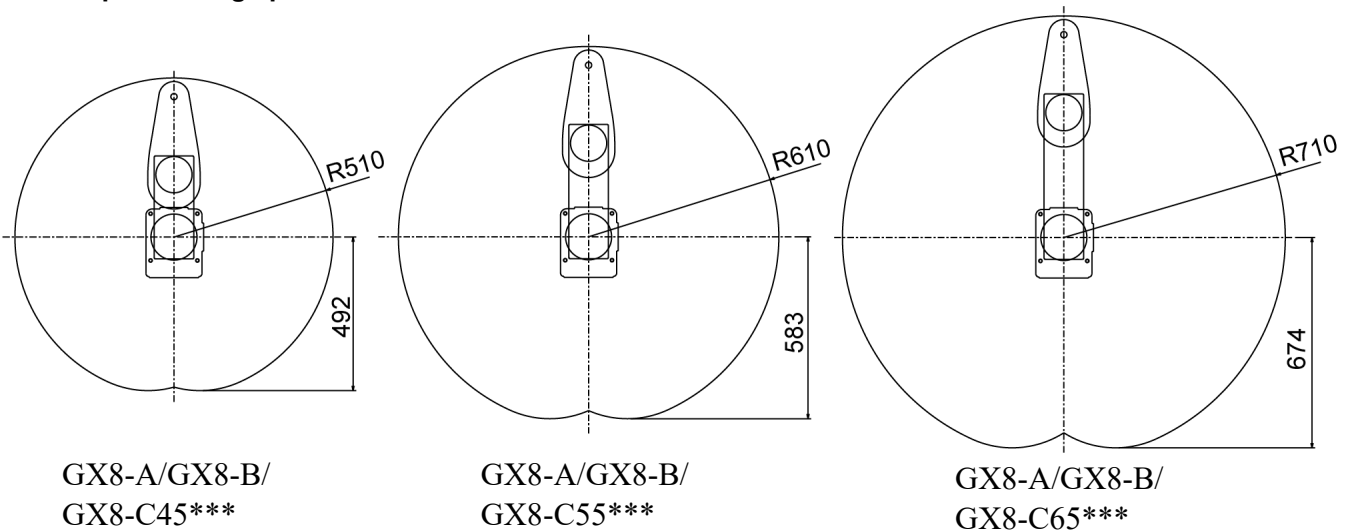

Wall mounting specifications

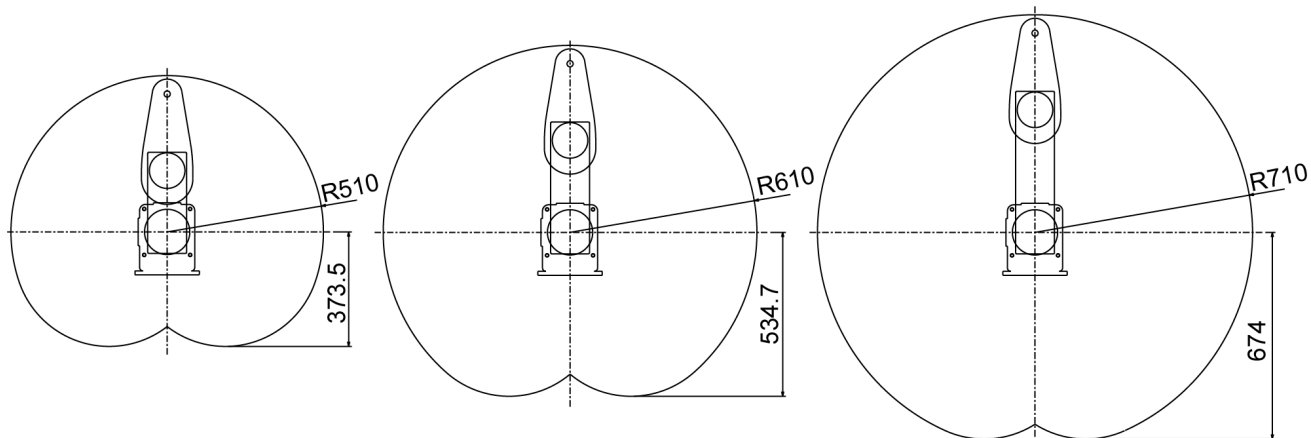

GX8-A/GX8-B/
GX8-C45**W

GX8-A/GX8-B/
GX8-C55**W

GX8-A/GX8-B/
GX8-C65**W

Ceiling mounting specifications

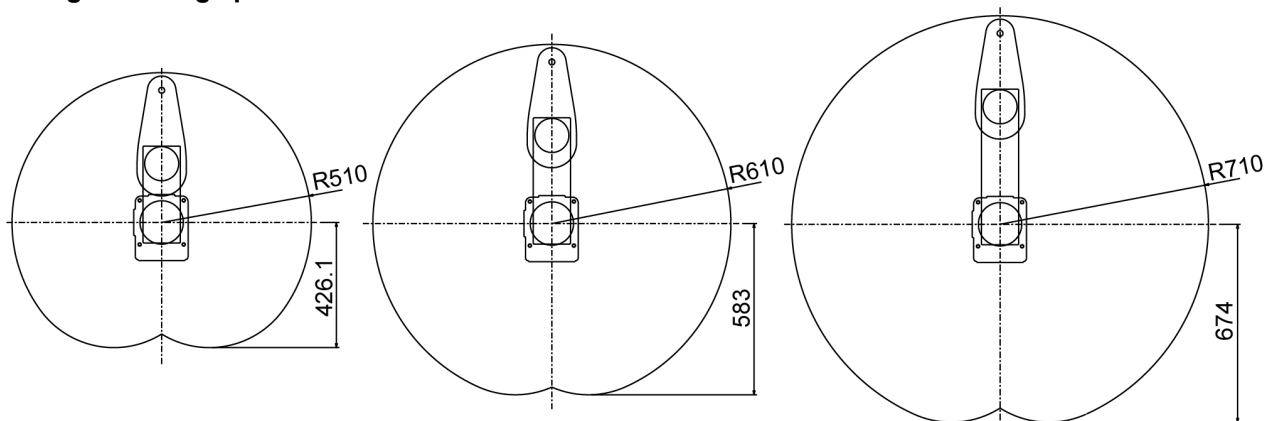

GX8-A/GX8-B/
GX8-C45**R

GX8-A/GX8-B/
GX8-C55**R

GX8-A/GX8-B/
GX8-C65**R

3.3.4 From Unpacking to Installation

3.3.4.1 Safety Information for the Flow from Unpacking to Installation

Transportation and installation of the Manipulator and related equipment should be performed by people who have received installation training provided by Epson and the suppliers. Also, the laws and regulations of the installation country must be followed.

⚠ WARNING

- Only qualified personnel should perform sling work and operate a crane or a forklift. When these operations are performed by unqualified personnel, it is extremely hazardous and may result in serious bodily injury to operators and/or severe equipment damage.

⚠ CAUTION

- Use a cart or the like to transport the Manipulator in the same status as it was delivered.
- After removing the fixing bolts securing the Manipulator to the transportation pallet, the Manipulator can fall. Be careful not to get your hands or feet caught in between the Manipulator.
- The arm is secured in place with cable ties or similar restraints. To prevent hands or other body parts from getting pinched in the robot arm, do not remove the cable ties until installation is complete.
- The Manipulator should be transported by two or more people, either secured to transporting equipment or carried by placing their hands under the shaded sections (the bottom of Arm #1 and bottom of the base). When holding the bottom of the base by hand, be extremely careful not to get your hands or fingers caught.

Table top mounting specifications

- GX8-A/GX8-B/GX8-C45***: Approx.33 kg (73 lb)
- GX8-A/GX8-B/GX8-C55***: Approx.34 kg (75 lb)
- GX8-A/GX8-B/GX8-C65***: Approx.35 kg (77 lb)

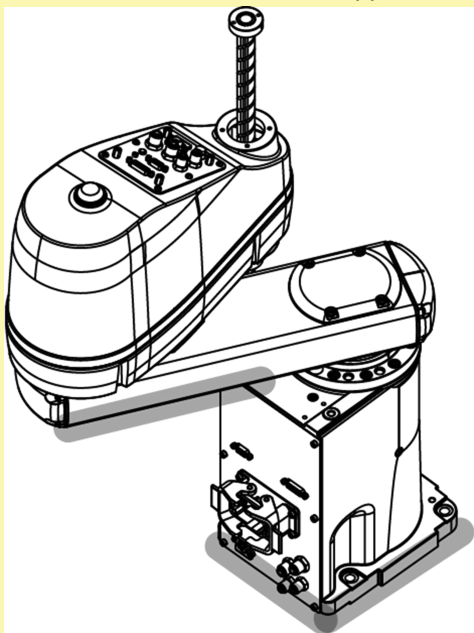

Wall mounting specifications

- GX8-A/GX8-B/GX8-C45**W: Approx.35 kg (77 lb)
- GX8-A/GX8-B/GX8-C55**W: Approx.36 kg (79 lb)

- GX8-A/GX8-B/GX8-C65**W: Approx.37 kg (82 lb)

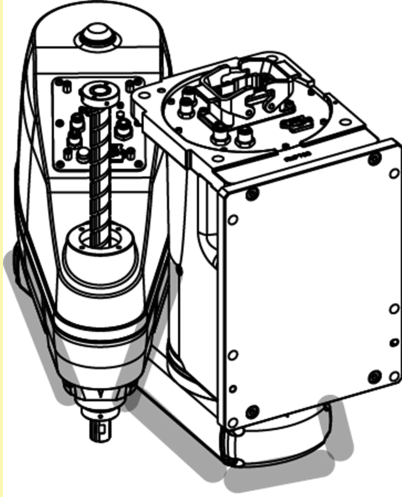

Ceiling mounting specifications

- GX8-A/GX8-B/GX8-C**R: Approx.33 kg (73 lb)
- GX8-A/GX8-B/GX8-C55**R: Approx.34 kg (75 lb)
- GX8-A/GX8-B/GX8-C65**R: Approx.35 kg (77 lb)

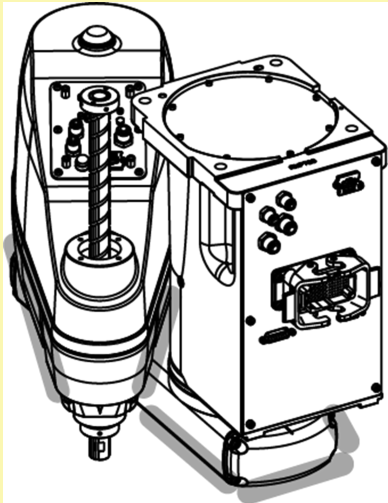

- When transporting the Manipulator over long distances, secure it directly to transporting equipment so that it will not fall. If necessary, pack the Manipulator using the same packaging as delivery.
- The Manipulator must be installed to avoid interference with surrounding buildings, structures, and other machines and equipment that may create a trapping hazard or pinch points.
- Resonance (resonating sound or minute vibrations) may occur during Manipulator operation depending on the rigidity of the base table. If the resonance occurs, improve the rigidity of the base table or change the speed or acceleration and deceleration settings of the Manipulator.

For details on the Manipulator installation procedure for models with standard specifications and ESD specifications, refer to the following sections.

- "Table Top Mounting Specifications"
- "Wall Mounting Specifications"
- "Ceiling Mounting Specifications"

For Manipulator models with cleanroom & ESD specifications and with protected-model, refer to the following sections.

- "Cleanroom & ESD Specifications"

- "Protected-Model"

The following procedure should be followed when transporting the Manipulator by hoisting.

1. Attach the eyebolts to the top of the Manipulator base.
2. Place the Manipulator arm in the extended position.
3. Ensure that the hoisting belt can be secured to Arm #2. Using the metal part of the shaded area as a guide, apply the band so that it does not shift.

 **KEY POINTS**

Please note that the plastic cover section may be damaged if a load is applied to it.

4. To prevent the Manipulator from falling over, lift while providing support at the position indicated by the arrow, and move it to the base table where it will be installed.

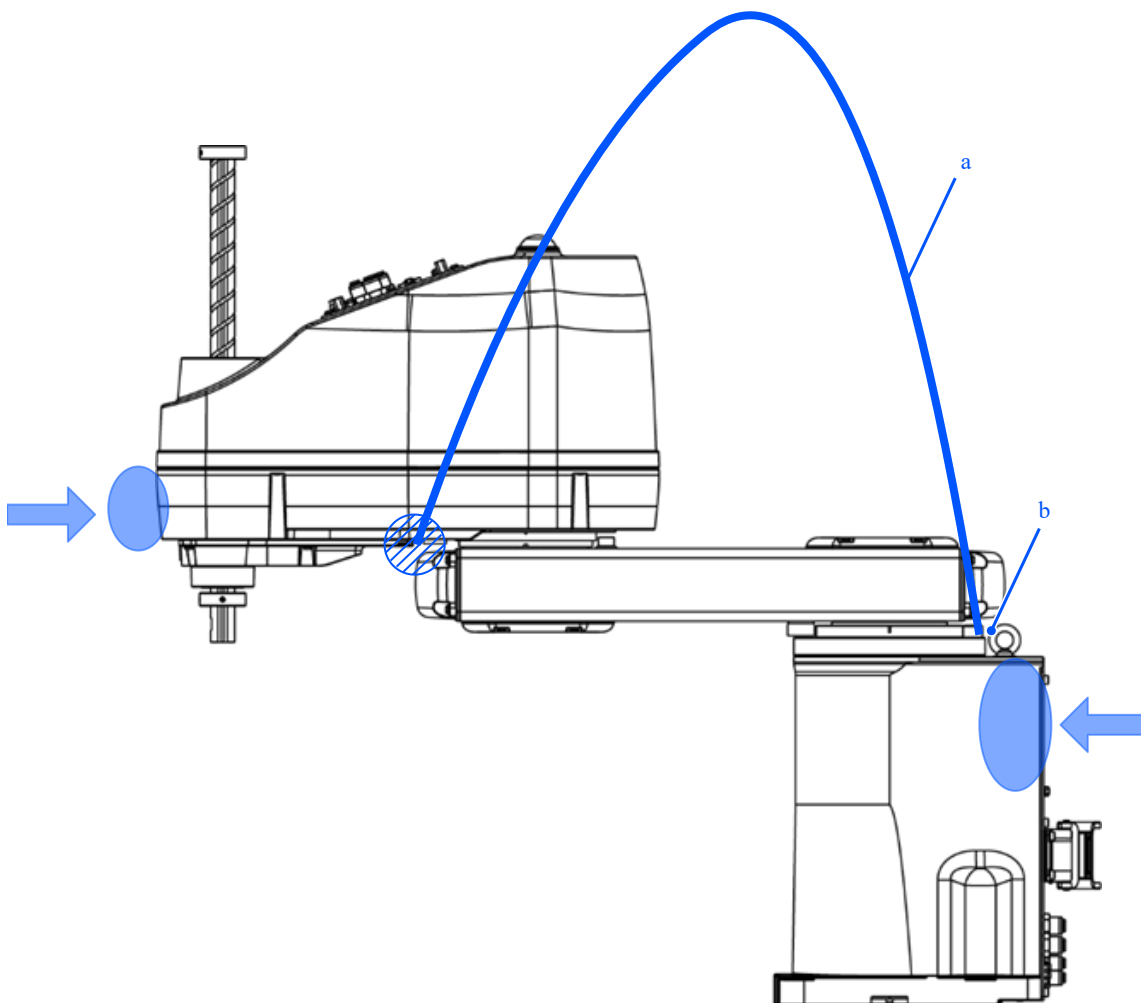

Symbol	Description
a	Hoisting belt
b	M8 eyebolts (included)

3.3.4.2 Table Top Mounting Specifications

⚠ CAUTION

Be sure to always use two or more people when installing or relocating the model with table top mounting specifications. The Manipulator weights are as follows. Be careful not to get hands or feet caught or have equipment damaged due to dropping of the Manipulator.

- GX8-A/GX8-B/GX8-C45***: Approx.33 kg (73 lb)
- GX8-A/GX8-B/GX8-C55***: Approx.34 kg (75 lb)
- GX8-A/GX8-B/GX8-C65***: Approx.35 kg (77 lb)

Standard-model

1. Secure the base to the base table using four bolts. Be sure to always use washers.

Tightening torque:

- M8: 32.0 N·m (326 kgf·cm)
- M10: 58.0 N·m (626 kgf·cm)

✍ KEY POINTS

Use bolts with strength specifications compliant with ISO 898-1 property class: 10.9 or 12.9.

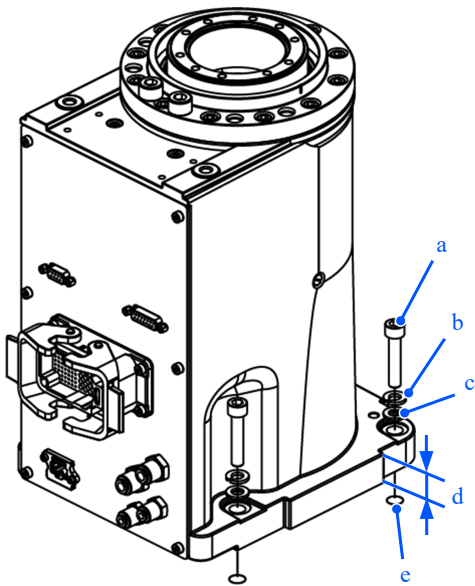

Symbol	Description
a	4 × M8 × 40
b	Spring washer
c	Plain washer
d	20 mm

Symbol	Description
e	Threaded hole 20 mm or more depth

2. Use a nippers or similar tool to cut the cable ties holding the arm in place.

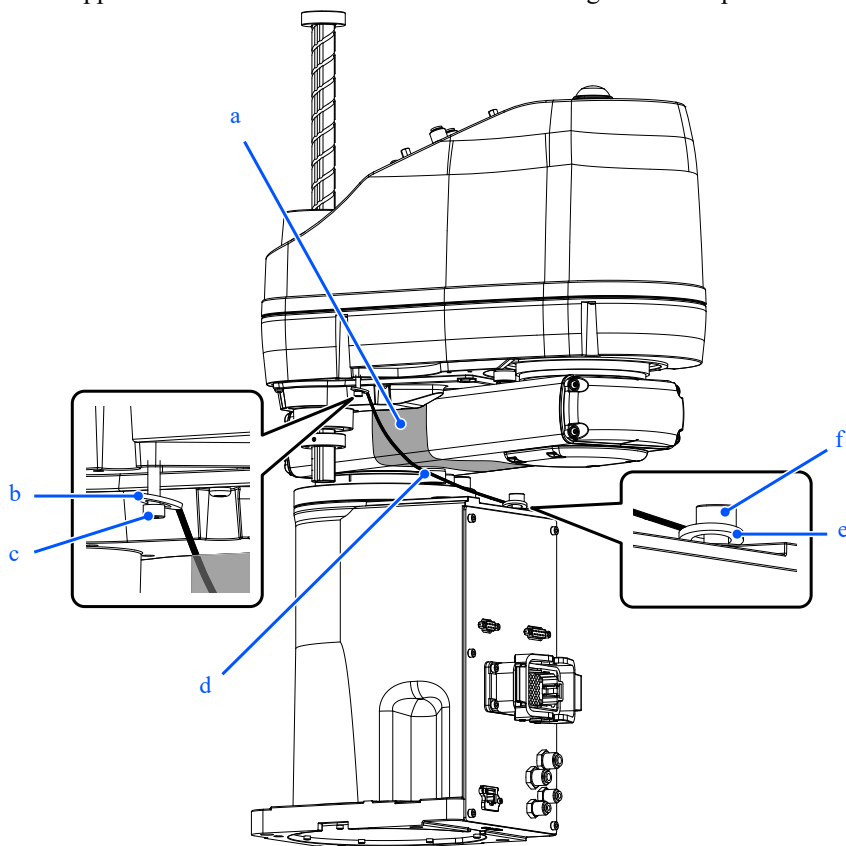

Symbol	Description
a	Sheet
b	Washer
c	Bolt: M4 × 35
d	Cable tie
e	Washer
f	Bolt: M8 × 20

3. Remove the bolts that secured the cable ties in step 2.

4. Remove the transportation fixtures.

KEY POINTS

If the cable is routed by exiting from the bottom side:

Make sure there is enough space in the center of the base table where the base will be secured in place.

Diameter: $\varnothing 150$ mm or more

Depth: M/C cable L-angle type 120 mm or more, M/C cable straight type 190 mm or more

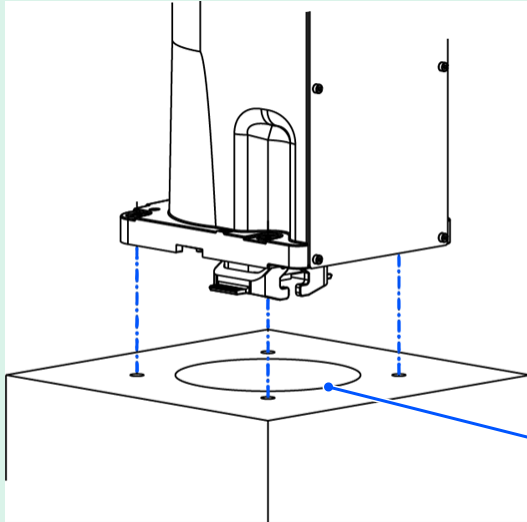

Diameter:
 $\varnothing 150$ mm or more
Depth:
120mm or more

3.3.4.3 Wall Mounting Specifications

WARNING

- Be sure to always use two or more people when installing or relocating the model with wall mounting specifications. The Manipulator weights are as follows. Be careful not to get hands or feet caught or have equipment damaged due to dropping of the Manipulator.
 - GX8-A/GX8-B/GX8-C45**W: Approx.35 kg (77 lb)
 - GX8-A/GX8-B/GX8-C55**W: Approx.36 kg (79 lb)
 - GX8-A/GX8-B/GX8-C65**W: Approx.37 kg (82 lb)
- When installing the Manipulator on a wall or similar structure, support the Manipulator until all of the anchor bolts are secured in place. Removing the support before the anchor bolts are fully secured is extremely hazardous and may cause the Manipulator to fall.

Standard specifications

1. With the arm extended, take out the Manipulator from the packing box.

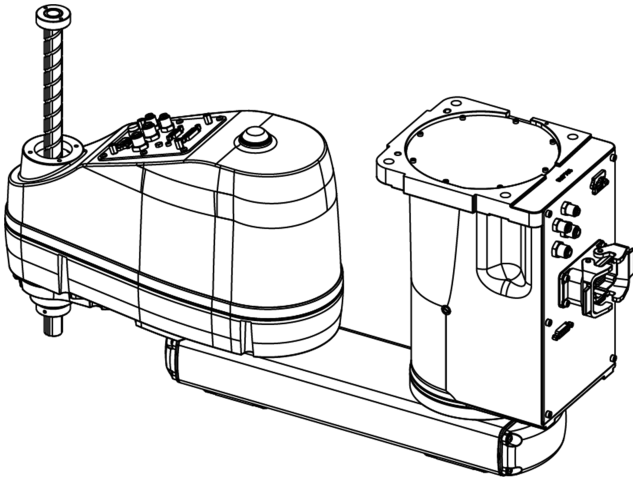

KEY POINTS

The joints may rotate due to the Manipulator's own weight. Be careful not to get your hands or fingers caught.

2. Secure the base to the wall using the six bolts.

Be sure to always use washers.

Tightening torque: 32.0 N·m (326 kgf·cm)

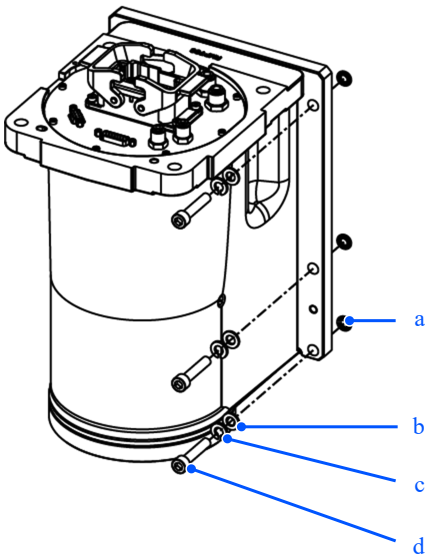

Symbol	Description
a	6 × M8 threaded hole 20 mm or more depth
b	6 × plain washer
c	6 × spring washer
d	6 × M8×40

 **KEY POINTS**

Use bolts with strength specifications compliant with ISO 898-1 property class: 10.9 or 12.9.

3. Remove the transportation fixtures.

3.3.4.4 Ceiling Mounting Specifications

 **WARNING**

- Be sure to always use two or more people when installing or relocating the model with ceiling mounting specifications. The Manipulator weights are as follows. Be careful not to get hands or feet caught or have equipment damaged due to dropping of the Manipulator.
 - GX8-A/GX8-B/GX8-C45**R: Approx.33 kg (73 lb)
 - GX8-A/GX8-B/GX8-C55**R: Approx.34 kg (75 lb)
 - GX8-A/GX8-B/GX8-C65**R: Approx.35 kg (77 lb)
- When installing the Manipulator on a ceiling or similar structure, support the Manipulator until all of the anchor bolts are secured in place. Removing the support before the anchor bolts are fully secured is extremely hazardous and may cause the Manipulator to fall.

Standard specifications

1. With the arm extended, take out the Manipulator from the packing box.

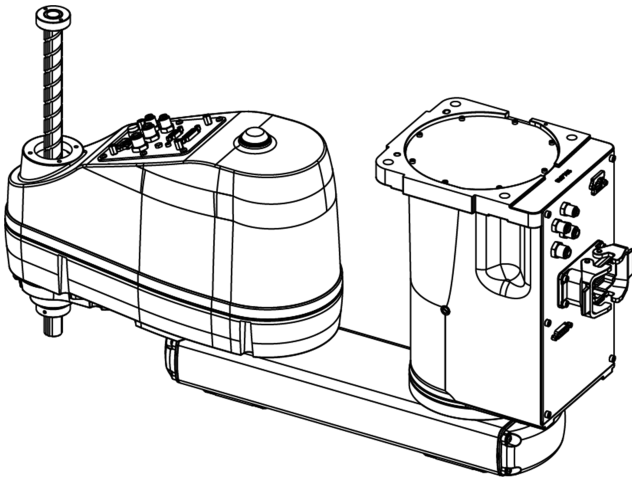

KEY POINTS

The joints may rotate due to the Manipulator's own weight. Be careful not to get your hands or fingers caught.

2. Secure the base to the ceiling using the four bolts. Be sure to always use washers.

Tightening torque:

- M8: 32.0 N·m (326 kgf·cm)
- M10: 58.0 N·m (592 kgf·cm)

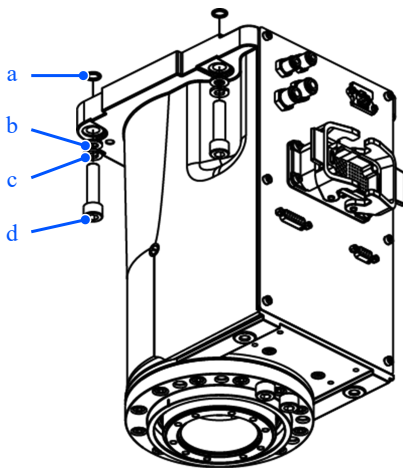

Symbol	Description
a	Threaded hole 20 mm or more depth
b	Plain washer
c	Spring washer
d	4 × M8 × 40

 **KEY POINTS**

Use bolts with strength specifications compliant with ISO 898-1 property class: 10.9 or 12.9.

3. Remove the transportation fixtures.

3.3.4.5 Cleanroom & ESD-Model

1. Unpack the Manipulator outside of the cleanroom.
2. Secure the Manipulator to transporting equipment (or a pallet) with bolts so that the Manipulator does not fall down.
3. Wipe off any dust on the Manipulator using a lint-free cloth that was dipped in ethyl alcohol or distilled water.
4. Carry the Manipulator into the cleanroom.
5. Refer to the installation procedure for the respective Manipulator model, and install the Manipulator.
 - Table Top Mounting Specifications
 - Wall Mounting Specifications
 - Ceiling Mounting Specifications
6. Connect an exhaust tube to the exhaust port.

When the Manipulator is a model with cleanroom & ESD specifications, an exhaust system must be connected. For details, refer to the following section.

[Appendix A: Specifications Table](#)

3.3.4.6 Protected-Model

Refer to the installation procedure for the respective Manipulator model, and install the Manipulator.

Table Top Mounting Specifications

Wall Mounting Specifications

Ceiling Mounting Specifications

When the Manipulator is a protected-model, take note of the following safety information.

 **WARNING**

- After the Manipulator is installed, immediately connect the M/C cable connector to the Manipulator. Leaving the Manipulator unconnected may result in electric shock and/or malfunction of the robot system because protection at IP65 cannot be ensured.

 **CAUTION**

- When operating Manipulators in special environments (oil smoke, dust, etc.), do not install the Controller in the same environment. The Controller does not satisfy the protection class (IP65). Using the Controller in these special environments may damage or lead to a breakdown of the Controller.

3.3.5 Connecting the Cables

WARNING

- To perform the power supply lockout, remove the power plug. Be sure to connect the AC power cable to a power outlet. Do not connect it directly to a factory power source.
- Before performing any replacement work, inform others in the area that you are working, and then turn off the Controller and related equipment, and unplug the power cable from the power source. Performing any work procedure with the power turned on is extremely dangerous and may result in electric shock and/or malfunction of the robot system.
- Be sure to connect the cables properly. Do not place heavy objects on the cables, bend them at extreme angles, pull them forcibly, or allow them to get pinched between objects. Damaged cables, broken wires, or contact failure is extremely hazardous and may result in electric shock and/or malfunction of the robot system.
- The Manipulator is grounded by connecting it to the Controller. Ensure that the Controller is grounded and the cables are correctly connected. If the ground wire is improperly connected to ground, it may result in the fire or electric shock.

CAUTION

- When connecting the Manipulator and the Controller, check that the serial numbers match for each device. Improper connection between the Manipulator and the Controller may not only lead to malfunction of the robot system but also serious safety problems. The connection method between the Manipulator and the Controller varies depending on the Controller. For details on the connections, refer to the following manual.

"Controller Manual"

When the Manipulator is a model with cleanroom & ESD specifications, please note the following points.

When the Manipulator is a model with cleanroom & ESD specifications, an exhaust system must be connected. For details, refer to the following section.

[Appendix A: Specifications Table](#)

When the Manipulator is a protected-model, please note the following points.

WARNING

- After the Manipulator is installed, immediately connect the M/C cable connector to the connector plate. Leaving the Manipulator unconnected may result in electric shock and/or malfunction of the robot system because protection at IP65 cannot be ensured.

CAUTION

- When operating Manipulators in special environments (oil smoke, dust, etc.), do not install the Controller in the same environment. The Controller does not satisfy the protection class (IP65). Using the Controller in these special environments may damage or lead to a breakdown of the Controller.

Connection procedure for Manipulator and M/C cable

Insert the M/C cable hood into the M/C cable housing on the back and bottom of the Manipulator, and secure it with the lock attached to the housing.

1. Open the lock plates on both sides of the M/C cable housing.
2. Insert the M/C cable hood all the way to the back.
3. Close the lock plates on both sides of the M/C cable housing.

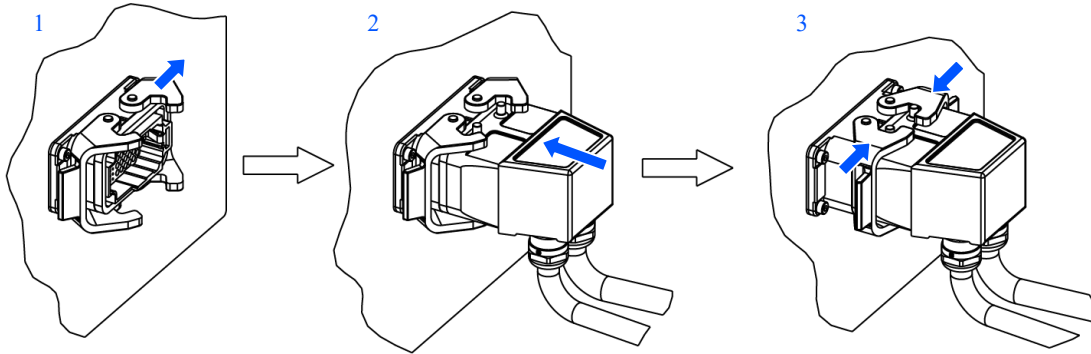

L-shape (Standard)		Straight	
Minimum Distance Required for Insertion and Removal	Distance When Mounted	Minimum Distance Required for Insertion and Removal	Distance When Mounted
120mm	100mm	210mm	190mm

Connecting the M/C cable and the Controller

Connect the power connector and signal connector of the M/C cable to the Controller.

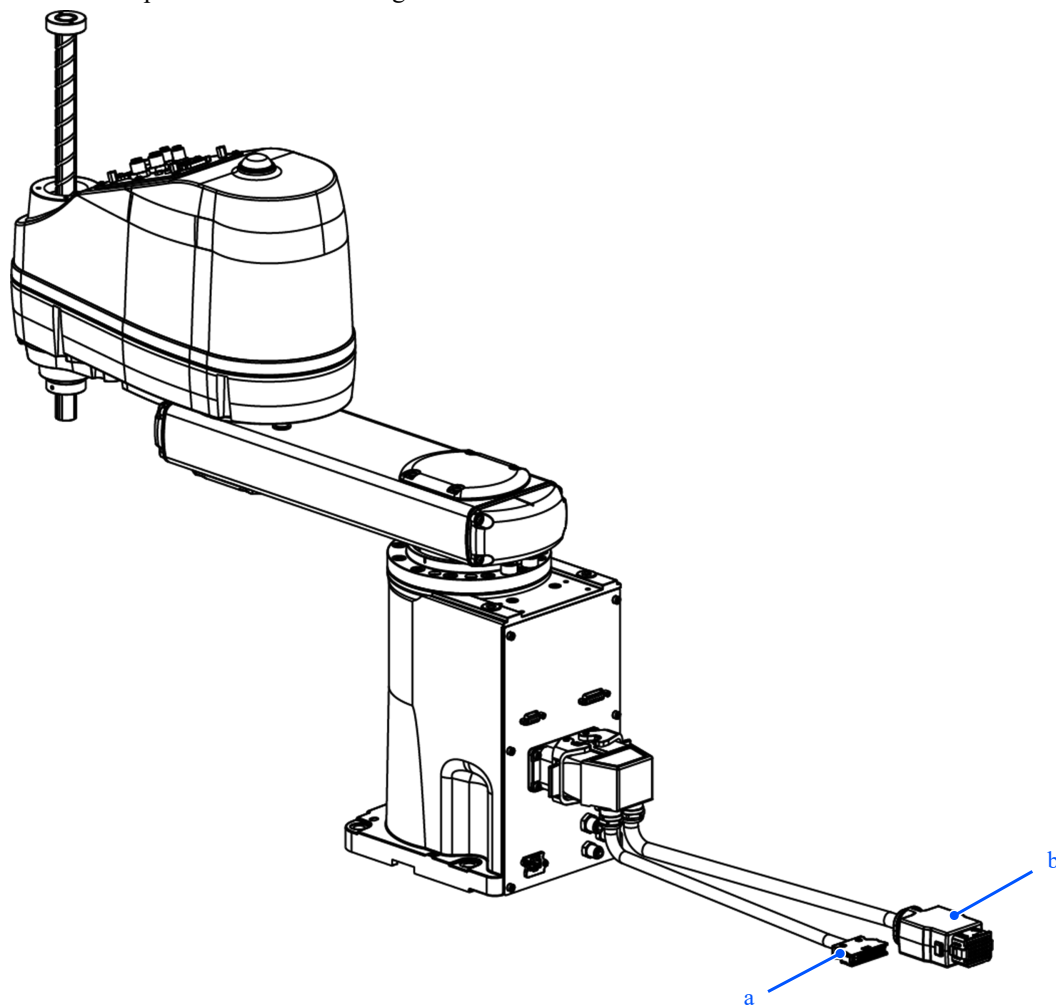

Symbol	Description
a	Signal connector
b	Power connector

There are two types of M/C cables: fixed and movable. Movable cables have wires as shown in the figure below.



3.3.6 User Wires and Pneumatic Tubes

⚠ CAUTION

- Only authorized or certified personnel should perform wiring. Wiring by unauthorized or uncertified staff may result in bodily injury and/or malfunction of the robot system.

3.3.6.1 Electrical Wires

Connect the following connectors and cables to the user connector of the Manipulator.

Manipulator cable specifications

	Rated Voltage	Allowable Current	Nominal Cross-sectional Area of Conductor	Remarks
D-sub 15pin D- 9pin	30V AC/DC	1.0A	0.08 mm ²	Shielded
RJ45	-	-	-	Equivalent to CAT5e

For each connector, pins with the same number are wired between the connector on the base side and the connector on the Arm #2 side in the Manipulator.

Connectors to the Manipulator (recommended)

Standard, ESD, cleanroom & ESD specifications

		Manufacturer	Model Number	Type	Remarks
D-sub 15 pin	Connector	Würth Elektronik	61801524823	Solder type	2 included
	Clamp hood	Würth Elektronik	61801525311	Connector setscrew: #4-40 UNC	2 included
D-sub 9 pin	Connector	Würth Elektronik	61800924823	Solder type	2 included
	Clamp hood	Würth Elektronik	61800925311	Connector setscrew: #4-40 UNC	2 included
RJ45	Connector	CommScope	6-569550-3-	-	-

Protected-model

		Manufacturer	Model Number	Type	Remarks
D-sub 15-pin	Connector	HARTING	09670155615	Solder type	2 included
	Clamp hood	HARTING	09670150538	Connector setscrew: #4-40 UNC	2 included
D-sub 9-pin	Connector	HARTING	09670095615	Solder type	2 included
	Clamp hood	HARTING	09670090538	Connector setscrew: #4-40 UNC	2 included
RJ45	Plug	HARTING	09451951560	-	-

3.3.6.2 Pneumatic Tubes

Manipulator pneumatic tube specifications

Maximum Working Pressure	Number of Tubes	O.D. × I.D.
0.59 Mpa (6 kgf/cm ² : 86 psi)	2	ø6 mm × ø4 mm
	2	ø4 mm × ø2.5 mm

For each connector inside the Manipulator, fittings of the same size and tip color (blue/white) are connected between the air fitting on the base side and the air fitting on the Arm #2 side.

Pneumatic tubes connected to the Manipulator (recommended)

Outer Diameter	Manufacturer	Model Number	Remarks
ø6 mm	SMC	TU0604*	Equivalent products from other companies can be used
ø4 mm	SMC	TU0425*	Equivalent products from other companies can be used

When the Manipulator is a protected-model, please note the following points.

⚠ CAUTION

- In special environments (e.g., oil smoke, dust, etc.), the user wires and pneumatic tubes should have protected-model (compliant with protection class IP65). If the user wires and pneumatic tubes without protected-model are connected, the protection class (IP65) cannot be guaranteed, and the Manipulator may be damaged or break down.
- Be sure to always connect the cap when the user cable connector is not being used.

If the cap is not attached, foreign matter such as oil smoke or dust may enter the connector, causing the Manipulator to be damaged or break down.

Arm #2 side (common to GX8 series)

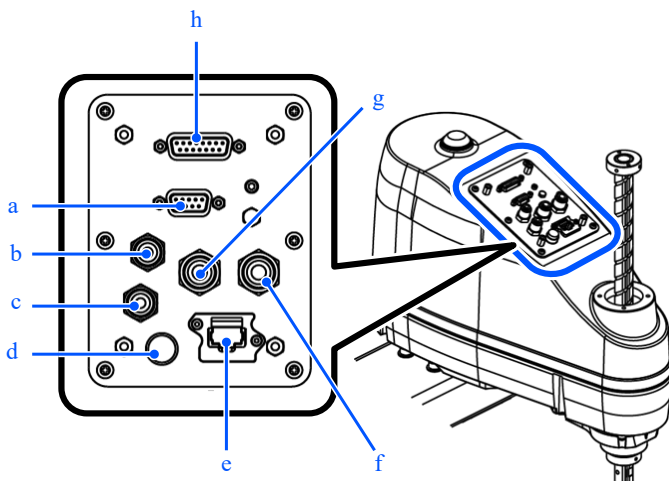

Symbol	Description
a	User connector (9-pin D-sub connector)
b	Fitting for ø4 mm tube (blue)
c	Fitting for ø4 mm tube (white)

Symbol	Description
d	Brake release switch
e	Ethernet connector
f	Fitting for ø6 mm tube (blue)
g	Fitting for ø6 mm tube (white)
h	User connector (15-pin D-sub connector)

Base side (table top mounting specifications)

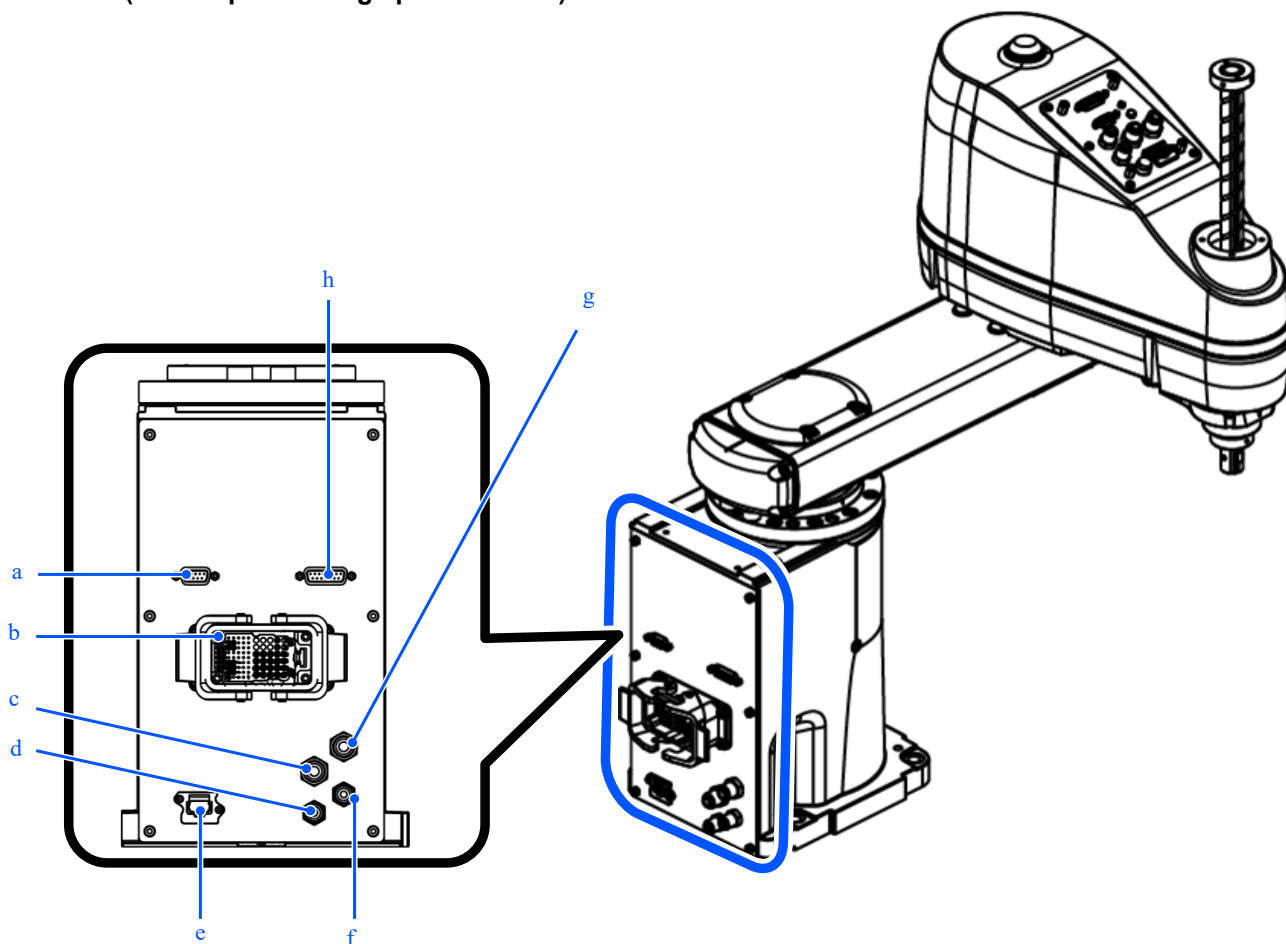

Symbol	Description
a	User connector (9-pin D-sub connector)
b	M/C cable housing
c	Fitting for ø6 mm tube (blue)
d	Fitting for ø4 mm tube (blue)
e	Ethernet connector
f	Fitting for ø4 mm tube (white)
g	Fitting for ø6 mm tube (white)
h	User connector (15-pin D-sub connector)

Base side (table top mounting specifications: cable routing from bottom side)

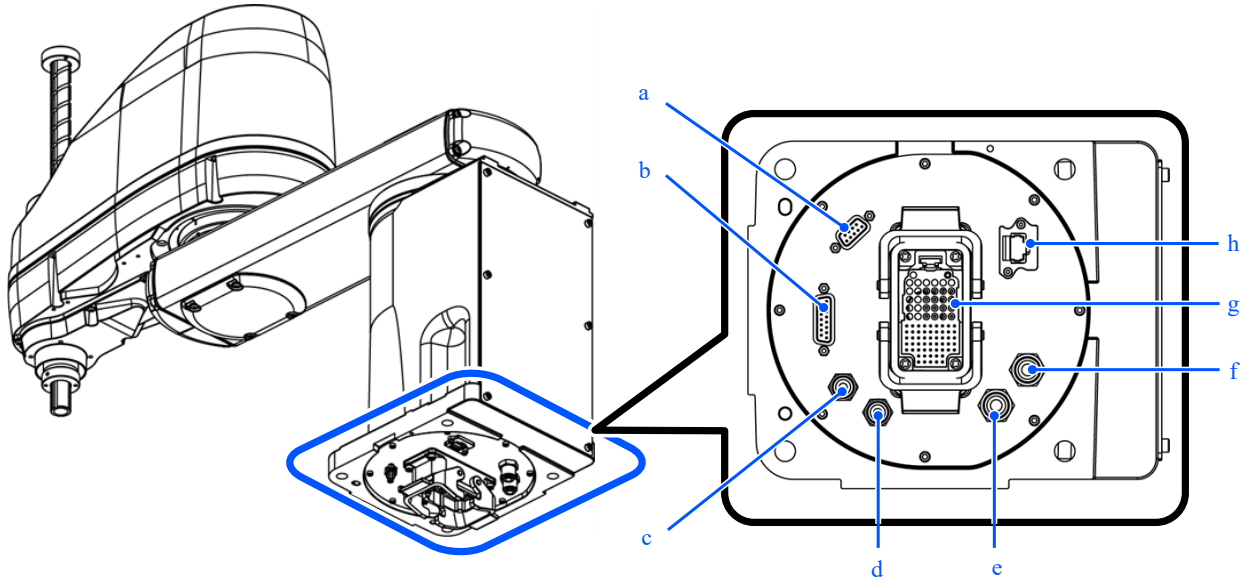

Symbol	Description
a	User connector (9-pin D-sub connector)
b	User connector (15-pin D-sub connector)
c	Fitting for ø4 mm tube (blue)
d	Fitting for ø4 mm tube (white)
e	Fitting for ø6 mm tube (blue)
f	Fitting for ø6 mm tube (white)
g	M/C cable housing
h	Ethernet connector

Base side (wall mounting specifications)

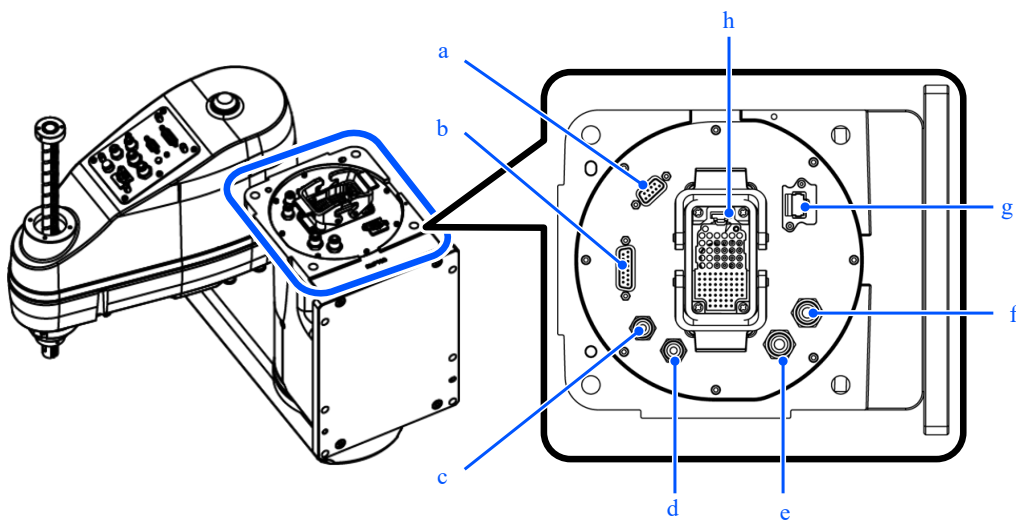

Symbol	Description
a	User connector (9-pin D-sub connector)
b	User connector (15-pin D-sub connector)

Symbol	Description
c	Fitting for ø4 mm tube (blue)
d	Fitting for ø4 mm tube (white)
e	Fitting for ø6 mm tube (blue)
f	Fitting for ø6 mm tube (white)
g	Ethernet connector
h	M/C cable housing

Base side (ceiling mounting specifications)

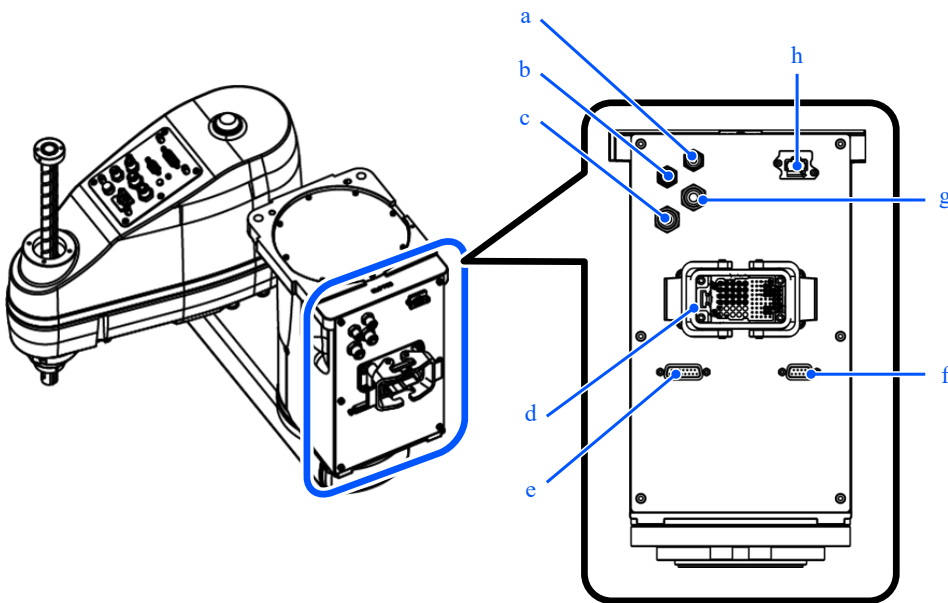

Symbol	Description
a	Fitting for ø4 mm tube (blue)
b	Fitting for ø4 mm tube (white)
c	Fitting for ø6 mm tube (white)
d	M/C cable housing
e	User connector (15-pin D-sub connector)
f	User connector (9-pin D-sub connector)
g	Fitting for ø6 mm tube (blue)
h	Ethernet connector

3.3.7 Relocation and Storage

3.3.7.1 Safety Information for Relocation and Storage

Pay attention to the following requirements when relocating, storing, and transporting the Manipulators. Transportation and installation of the Manipulator and related equipment should be performed by people who have received

installation training provided by Epson and the suppliers. Also, the laws and regulations of the installation country must be followed.

WARNING

- Only qualified personnel should perform sling work and operate a crane or a forklift. When these operations are performed by unqualified personnel, it is extremely hazardous and may result in serious bodily injury to operators and/or severe equipment damage.

CAUTION

- Before relocating, fold the arm and secure it tightly with a cable tie to prevent hands or fingers from getting caught in the Manipulator.
- When removing the anchor bolts, support the Manipulator so that it does not fall. Removing the anchor bolts without supporting the Manipulator can cause it to fall, causing hands or feet to get caught.
- The Manipulator should be transported by three or more people, either secured to transporting equipment or carried by placing their hands under Arm #1 or the bottom of the base. When holding the bottom of the base by hand, be extremely careful not to get your hands or fingers caught.

When transporting the Manipulator over long distances, secure it directly to transporting equipment so that it will not fall. If necessary, pack the Manipulator using the same packaging as delivery.

When the Manipulator is reassembled and used for a robot system again after an extended period of storage, perform a test run to verify that it works properly before starting the main operation.

Manipulators should be transported and stored under the following conditions: Temperature: -20 to +60°C, Humidity: 10 to 90% (no condensation)

If condensation has formed on the Manipulator during transportation or storage, do not turn on the power until the condensation is removed.

Do not subject the Manipulator to excessive impacts or vibrations during the transportation process.

3.3.7.2 Table Top Mounting Specifications

CAUTION

- Be sure to use four or more people when installing or relocating a model with table top mounting specifications, and use three or more people when lifting a Manipulator. The Manipulator weights are as follows. Be careful not to get hands or feet caught or have equipment damaged due to dropping of the Manipulator.
 - GX8-A/GX8-B/GX8-C45***: Approx.33 kg (73 lb)
 - GX8-A/GX8-B/GX8-C55***: Approx.34 kg (75 lb)
 - GX8-A/GX8-B/GX8-C65***: Approx.35 kg (77 lb)

1. Turn off all power, and remove the wiring and tubes connected to the Manipulator.

KEY POINTS

If using variable mechanical stops for Joints #1 and #2 and the operating angle is limited, change to the mechanical stop positions at factory shipping.

Setting the Work Envelope by Mechanical Stops

2. Wrap a sheet around the arm so that it will not get damaged.
Bind the lower end of the shaft to the arm and the base to the arm. Secure the arm while referring to the figure below.

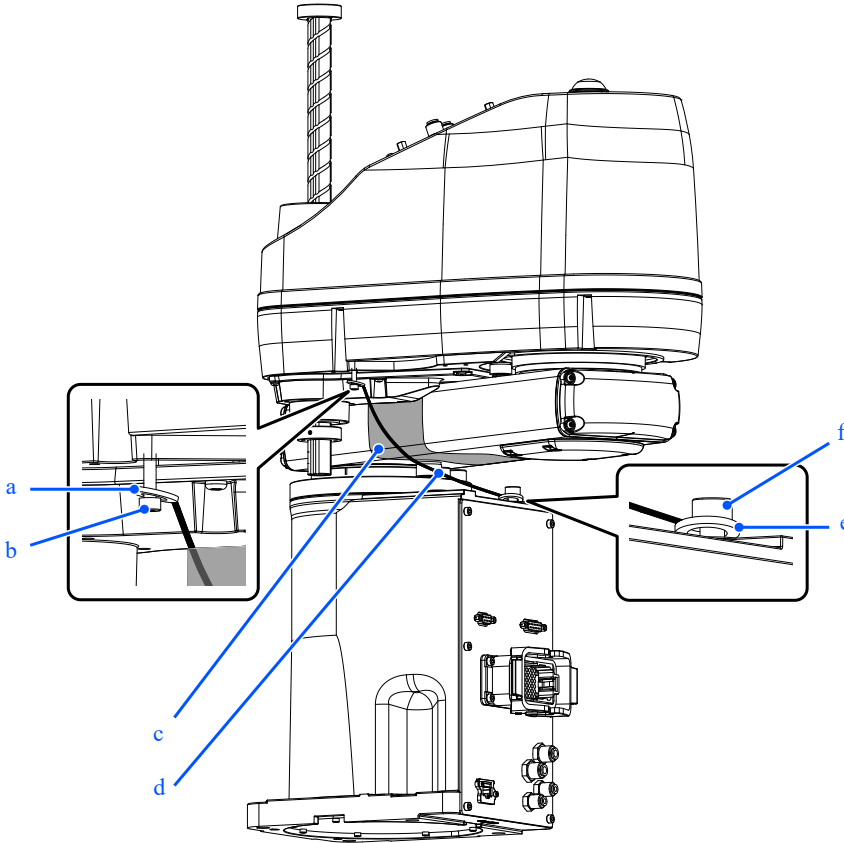
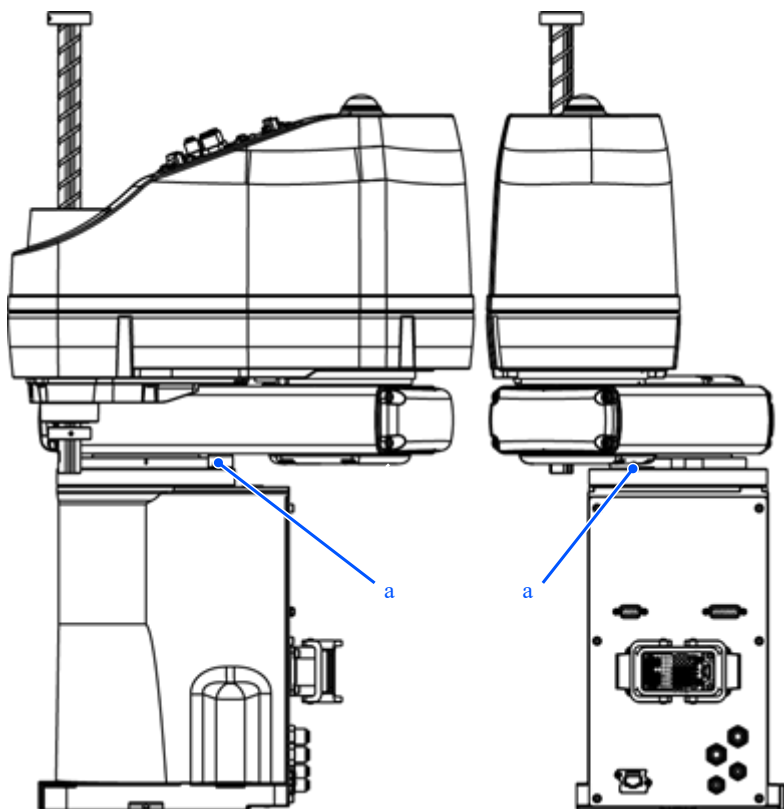

Illustration: GX8-A552S

Symbol	Description
a	Washer
b	Bolt: M4 × 35
c	Sheet
d	Cable tie
e	Washer
f	Bolt: M8 × 20

3. While supporting the bottom of Arm #1 by hand so that the Manipulator does not fall over, remove the anchor bolts. Then, remove the Manipulator from the base table.

GX8-A/GX8-B/GX8-C45***



Symbol	Description
a	Center of gravity

GX8-A/GX8-B/GX8-C55***

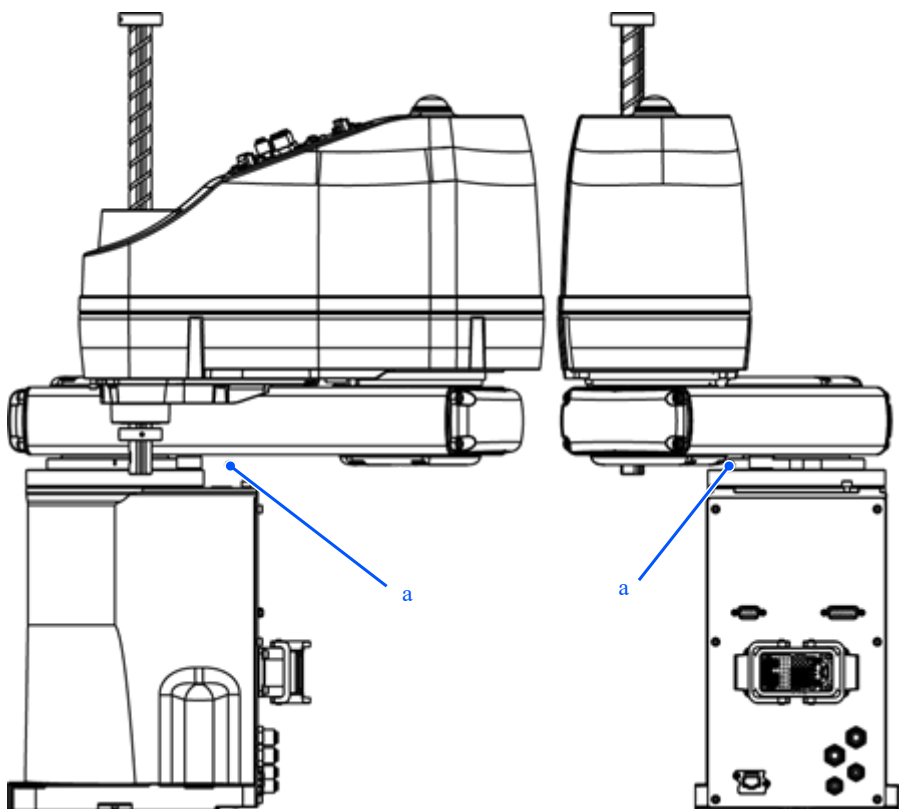

Symbol	Description
a	Center of gravity

GX8-A/GX8-B/GX8-C65***

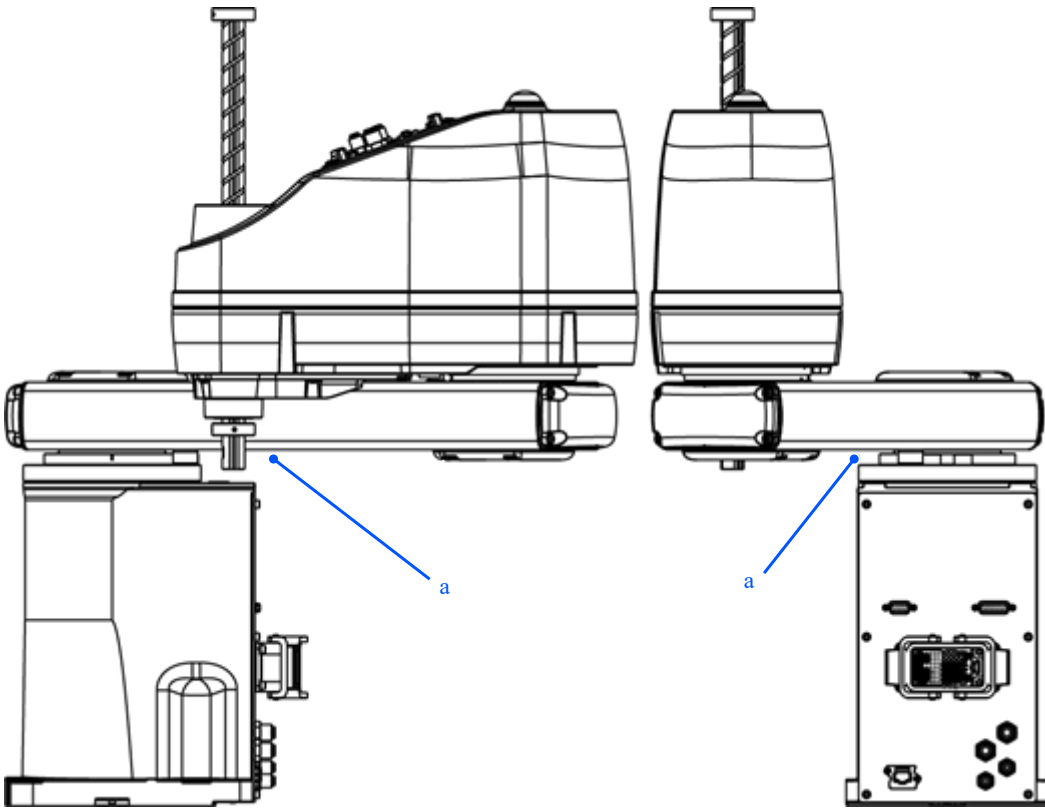

Symbol	Description
a	Center of gravity

3.3.7.3 Wall Mounting Specifications

⚠ WARNING

- Be sure to always use two or more people when installing or relocating the model with wall mounting specifications. The Manipulator weights are as follows. Be careful not to get hands or feet caught or have equipment damaged due to dropping of the Manipulator.
 - GX8-A/GX8-B/GX8-C45**W: Approx.35 kg (77 lb)
 - GX8-A/GX8-B/GX8-C55**W: Approx.36 kg (79 lb)
 - GX8-A/GX8-B/GX8-C65**W: Approx.37 kg (82 lb)
- When removing the Manipulator from a wall or other location, be sure to support the Manipulator before removing the anchor bolts. Removing the anchor bolts without supporting the Manipulator is extremely hazardous and may cause the Manipulator to fall.

1. Turn off all power, and remove the wiring and tubes connected to the Manipulator.

KEY POINTS

If using variable mechanical stops for Joints #1 and #2 and the operating angle is limited, change to the mechanical stop positions at factory shipping.

Setting the Work Envelope by Mechanical Stops

2. Wrap a sheet around the arm so that it will not get damaged. Secure the arm while referring to the figure.

Example of securing arm in place

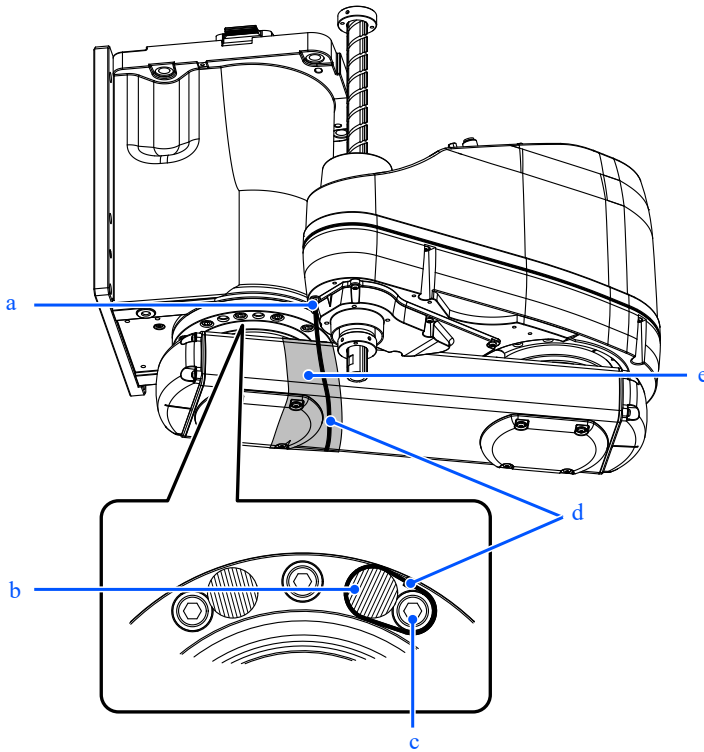

Symbol	Description
a	Bolt: M4 × 15 Washer
b	Arm #1 stop bolt
c	Arm fixing bolt
d	Cable tie
e	Sheet

3. While supporting the bottom of Arm #1 by hand so that the Manipulator does not fall over, remove the anchor bolts. Then, remove the Manipulator from the wall.

GX8-A/GX8-B/GX8-C45W**

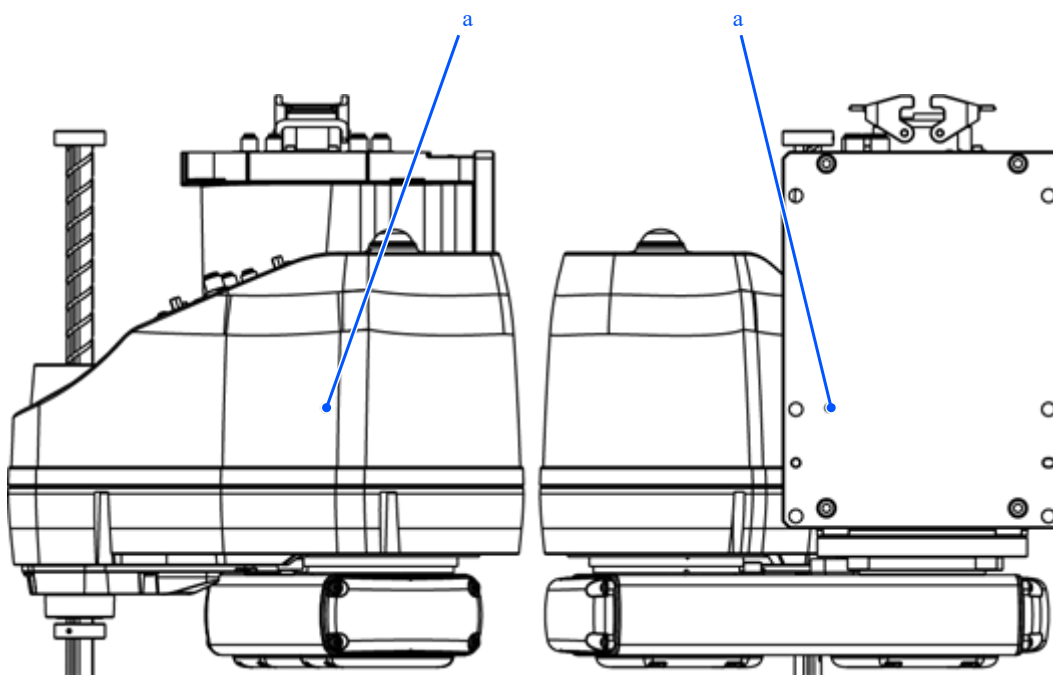

Symbol	Description
a	Center of gravity

GX8-A/GX8-B/GX8-C55W**

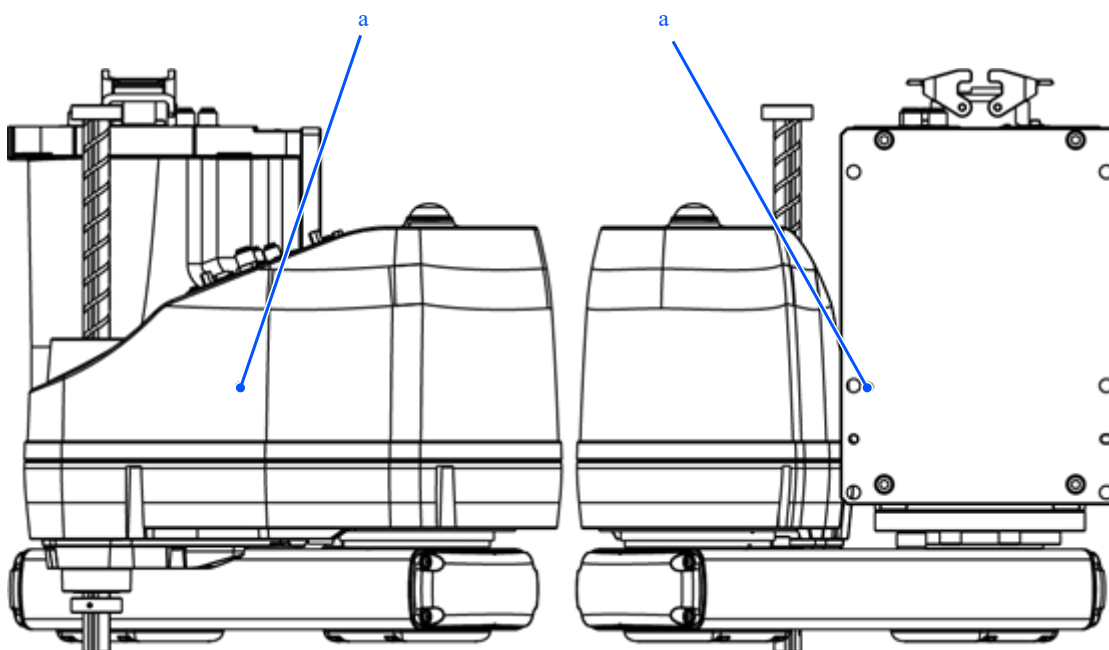

Symbol	Description
a	Center of gravity

GX8-A/GX8-B/GX8-C65W**

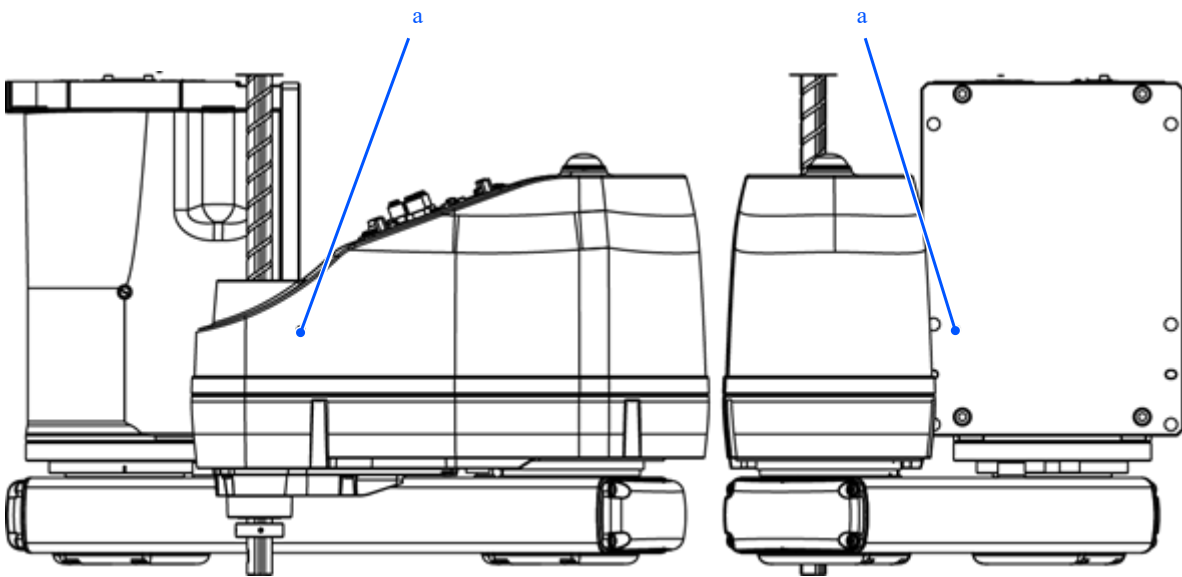

Symbol	Description
a	Center of gravity

3.3.7.4 Ceiling Mounting Specifications

WARNING

- Be sure to always use two or more people when installing or relocating the model with ceiling mounting specifications. The Manipulator weights are as follows. Be careful not to get hands or feet caught or have equipment damaged due to dropping of the Manipulator.
 - GX8-A/GX8-B/GX8-C45**R: Approx.33 kg (73 lb)
 - GX8-A/GX8-B/GX8-C55**R: Approx.34 kg (75 lb)
 - GX8-A/GX8-B/GX8-C65**R: Approx.35 kg (77 lb)
- When removing the Manipulator from a ceiling surface or other location, be sure to support the Manipulator before removing the anchor bolts. Removing the anchor bolts without supporting the Manipulator is extremely hazardous and may cause the Manipulator to fall.

1. Turn off all power, and remove the wiring and tubes connected to the Manipulator.

KEY POINTS

If using variable mechanical stops for Joints #1 and #2 and the operating angle is limited, change to the mechanical stop positions at factory shipping.

Setting the Work Envelope by Mechanical Stops

2. Wrap a sheet around the arm so that it will not get damaged. Secure the arm while referring to the figure.

Example of securing arm in place

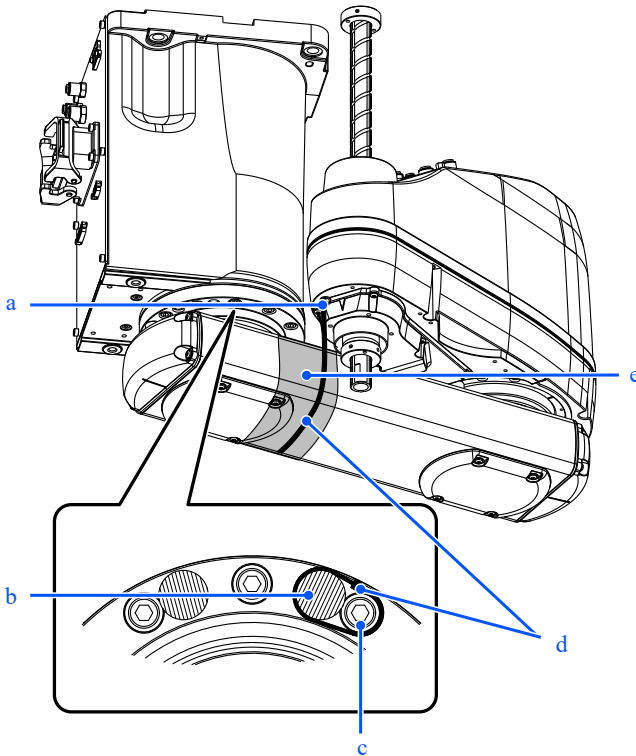

Symbol	Description
a	Bolt: M4 × 15 Washer
b	Arm #1 stop bolt
c	Arm fixing bolt
d	Cable tie
e	Sheet

3. While supporting the bottom of Arm #1 by hand so that the Manipulator does not fall over, remove the anchor bolts. Then, remove the Manipulator from the ceiling.

GX8-A/GX8-B/GX8-C45R**

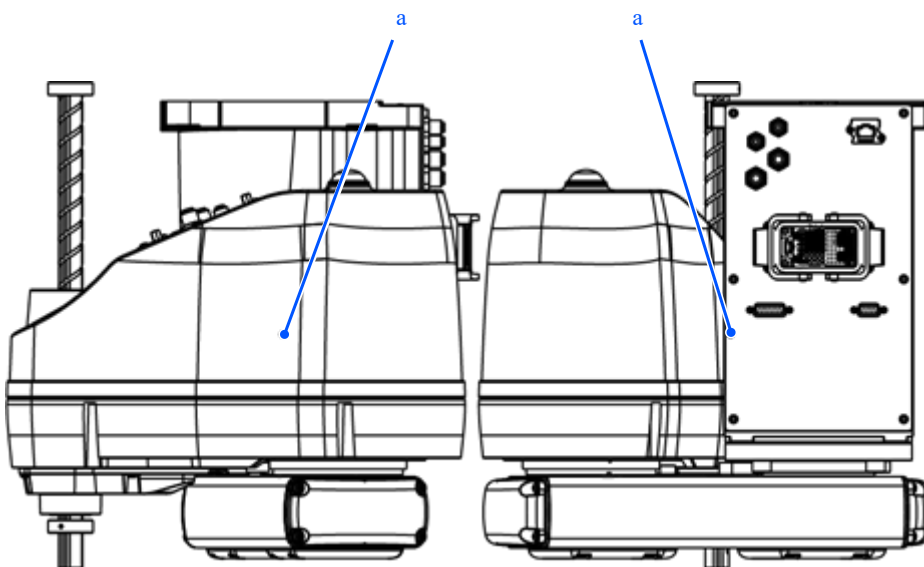

Symbol	Description
a	Center of gravity

GX8-A/GX8-B/GX8-C55R**

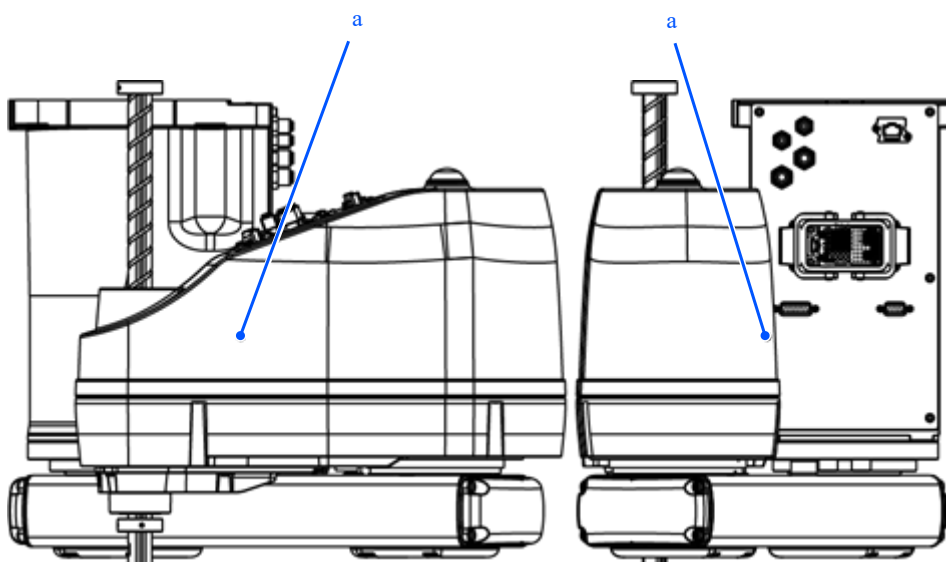

Symbol	Description
a	Center of gravity

GX8-A/GX8-B/GX8-C65R**

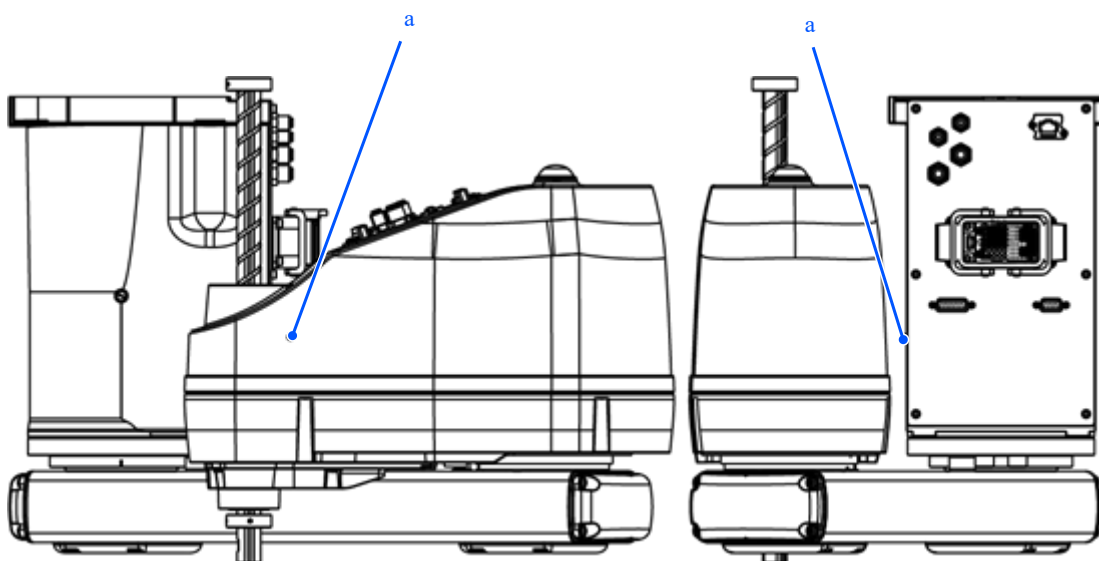

Symbol	Description
a	Center of gravity

3.4 Setting the Hand

3.4.1 Installing the Hand

The hand (end effector) must be prepared by the customer. When installing the hand, take note of the following. For details on attaching the hand, refer to the following manual.

"Hand Function Manual"

WARNING

- Before attaching a hand or peripheral equipment, be sure to always turn off the Controller and related equipment and unplug the power cables. Performing any work procedure with the power turned on is extremely dangerous and may result in electric shock and/or malfunction of the robot system.

CAUTION

When the hand is equipped with a workpiece gripping mechanism, ensure that the wiring and pneumatic tubes do not cause the hand to release the workpiece when the power is turned off. When the wiring and pneumatic tubes are not designed for the hand to maintain its grip on the workpiece when the power is turned off, pressing the emergency stop switch releases the workpiece, which may damage the robot system and the workpiece.

By default, all I/Os are designed to automatically turn off (0) when the power is shut off, when an emergency stop is triggered, or by the robot system's safety function.

However, I/Os set with the Hand function does not turn off (0) when executing the Reset statement, or when performing an emergency stop.

For the risk of the residual air pressure, conduct a risk assessment on the equipment and take the necessary protective measures.

Shaft

- Attach the hand to the lower end of the shaft.
For the layout dimensions in the area around the shaft and the overall dimensions of the Manipulator, refer to the following section.
[Names of Parts and Their Dimensions](#)
- Do not move the upper limit mechanical stop on the lower side of the shaft. When performing a Jump operation, the upper limit mechanical stop may come into contact with the Manipulator body, which may cause the Manipulator to stop functioning properly.
- When attaching the hand to the shaft, have the hand hold the shaft using M4 or larger screws.

Brake release switch

- Joint #3 and Joint #4 have an electromagnetic brake that is triggered when the power is off, preventing them from being moved up and down or rotated by hand.

To move Joint #3 up or down or rotate Joint #4 when attaching a hand, turn on the Controller, and then press the brake release switch.

This button switch is a momentary brake release type where the brake is released only while the button switch is being pressed. The switch releases the brake of Joints #3 and #4 simultaneously.

- When pressing the brake release switch, watch for the shaft descending or rotating under the weight of the hand.
- *: The shaft may drop due to the weight of the hand or other object.

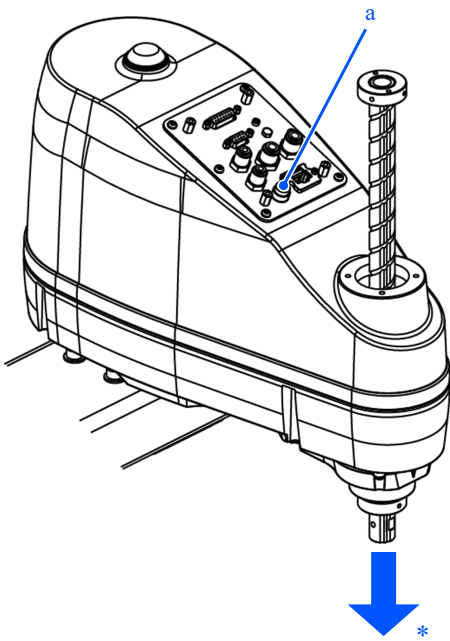

Symbol	Description
a	Brake release switch

Layout

- When attaching and operating a hand, the hand may come into contact with the Manipulator body due to the outer diameter of the hand, the size of the workpiece, or the position of the arm. Carefully consider the interference area of the hand when designing the system layout.

3.4.2 Attaching Cameras and Valves

The base and Arm #2 (top and bottom surfaces) have threaded holes as shown in the figure below. Use the threaded holes in Arm #2 (bottom surface) for attaching cameras, valves, and other heavy objects to the Manipulator.

When attaching pneumatic tubes, Ethernet cables, and other objects to the threaded holes in Arm #2 (top surface), do not exceed the following allowable loads.

- With an external wiring unit installed: 250 g (assuming a distance of 100 mm from the mounting surface to center of gravity)
- Without an external wiring unit installed: 750 g (assuming a distance of 100 mm from the mounting surface to center of gravity)

Common for all models

(Units: mm)

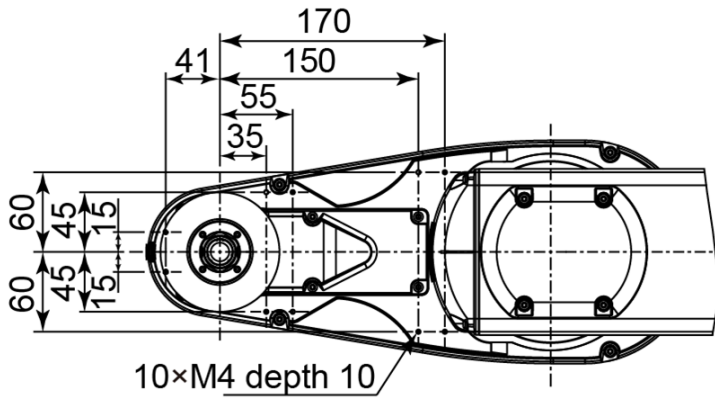

Table top mounting specifications

(Units: mm)

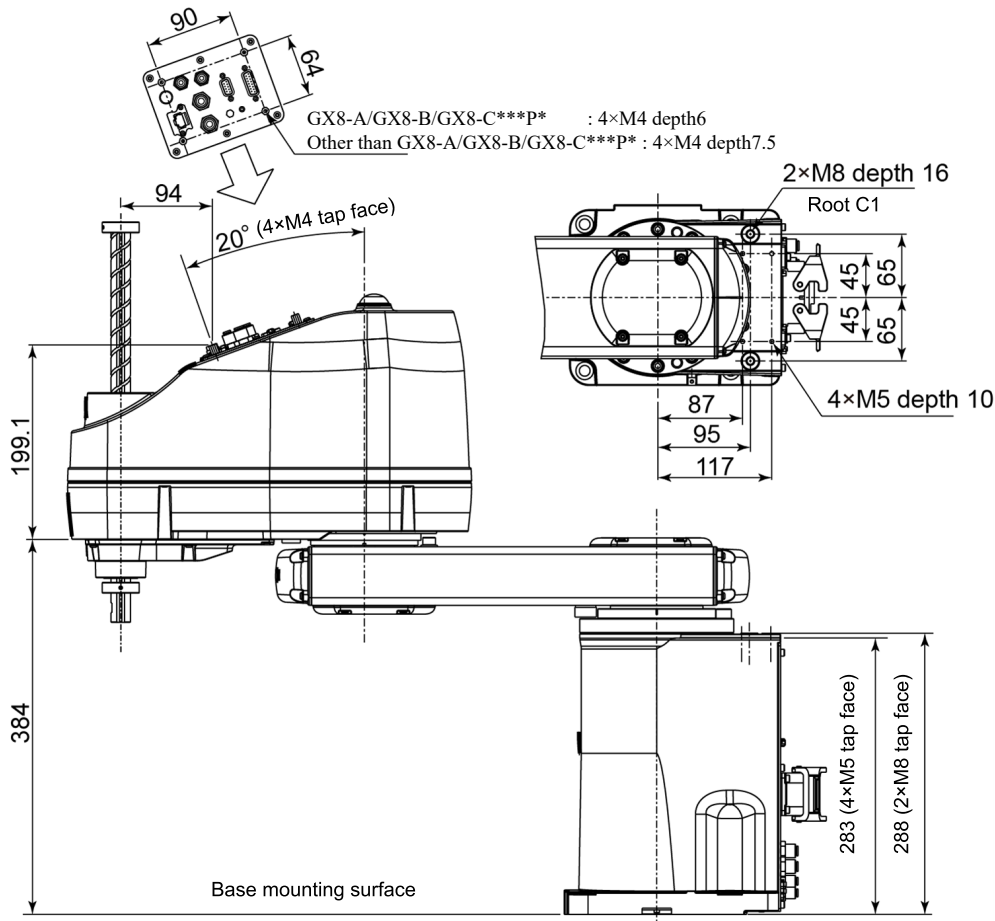
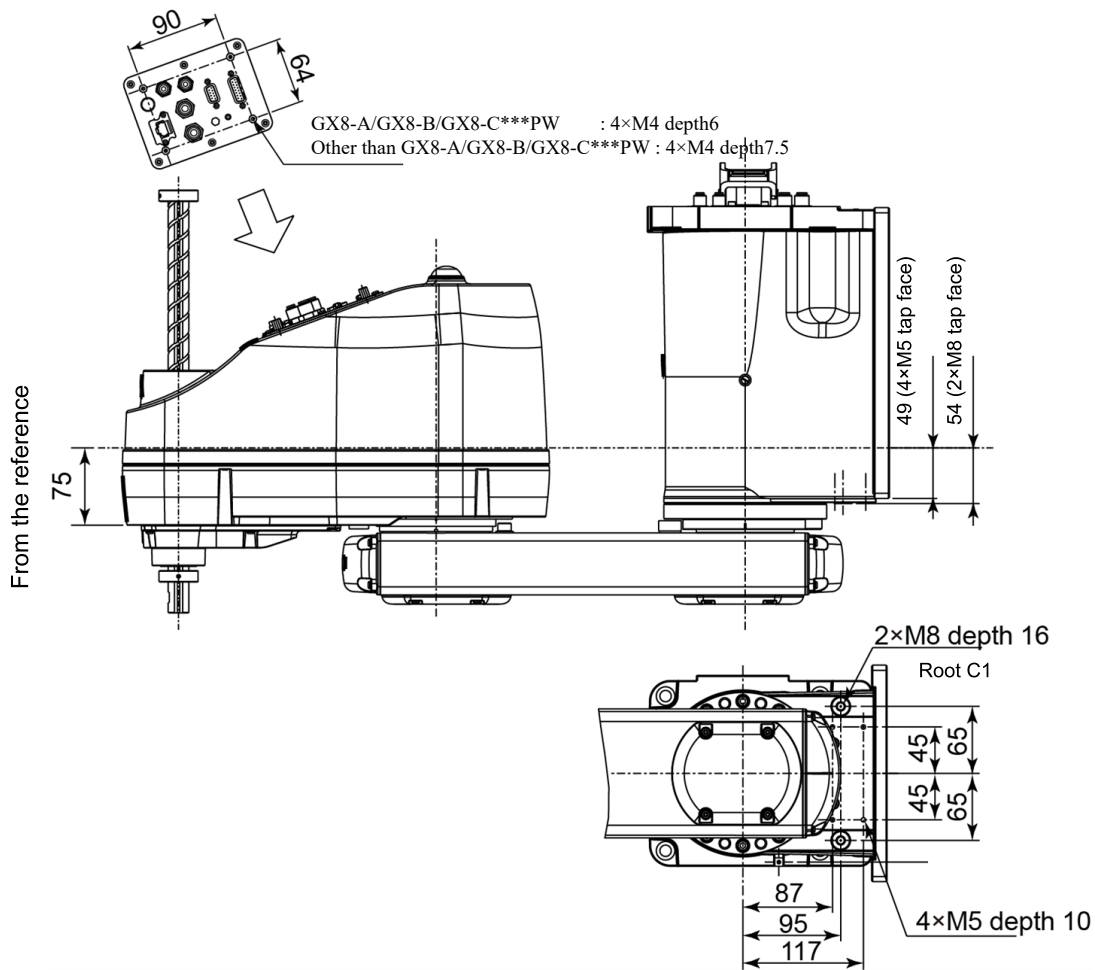

Illustration: GX8-A552S

Wall mounting specifications

(Units: mm)



Ceiling mounting specifications (Units: mm)

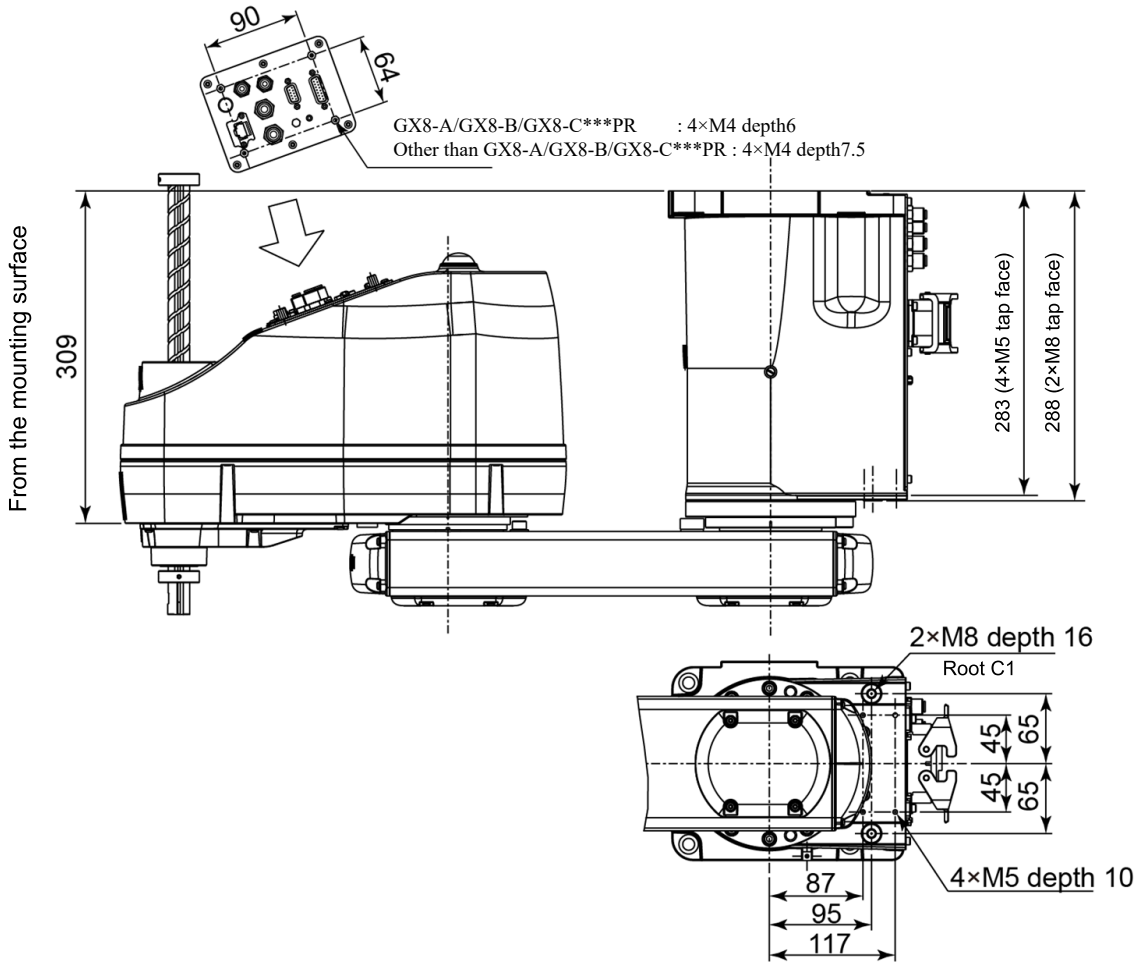

3.4.3 Weight and Inertia Settings

To ensure that the Manipulator is functioning properly, keep the load (the sum of the weights of the hand and workpiece) and the moment of inertia of the load within the rated values, and do not allow for eccentricity from the center of the Joint #4. If, for some unavoidable reason, the load or moment of inertia exceeds the rated value, or if eccentricity occurs, configure parameters as described in the "Weight setting" and "Inertia setting."

These settings optimize the Manipulator's PTP motion, reduce vibration, and shorten operation times. This also works to curb any persistent vibration that may occur when the hand and workpiece have a large moment of inertia.

You can also perform settings using the "Weight, Inertia, and Eccentricity/Offset Measurement Utility".

For details, refer to the following manual:

"Epson RC+ User's Guide - Weight, Inertia, and Eccentricity/Offset Measurement Utility"

3.4.3.1 Weight Setting

⚠ CAUTION

- The total weight of the hand and the workpiece must not exceed 8 kg. The GX8 series Manipulators are not designed to work with loads exceeding 8 kg. Always set the value according to the load. Setting the hand weight parameter to a value smaller than the actual weight may cause errors or impact that not only impair full functionality but also shorten the life of the mechanical components.

The allowable load weight (hand and workpiece) in the GX8 series is 4 kg at the default rating and 8 kg at the maximum. Depending on the load weight, change the setting for the hand weight parameter in the Weight statement. After the setting is changed, the maximum speed and acceleration/deceleration of the Manipulator during PTP motion that correspond to the "Hand Weight" are corrected automatically.

3.4.3.1.1 Weight of Load Attached to Shaft

The weight of the load (hand + workpiece) attached to the shaft can be set by the "Hand Weight" parameter in the Weight statement.

Epson
RC+

Go to [Tools] - [Robot Manager] - [Weight] panel, and enter the value in the [Weight] text box. (This can also be set using the Weight statement in [Command Window].)

3.4.3.1.2 Weight of Load Attached to Arm

When a camera, valve, or other object is attached to the arm, its weight is converted to the equivalent weight of the shaft and added to the weight of the load attached to shaft to set the "Hand Weight" parameter.

If an external wiring unit (excluding cables) is installed near the user connector on the Arm #2 side, add 0.16 kg to the equivalent weight conversion value of the shaft.

Equivalent weight formula

$$W_M = M \times (L_M + L_1)^2 / (L_1 + L_2)^2$$

W_M : Equivalent weight

M : Weight of load attached to the arm

L_1 : Length of Arm #1

L_2 : Length of Arm #2

L_M : Distance from rotation center of Joint #2 to center of gravity of load attached to the arm

Example:

Calculates [Weight] parameter when a 1 kg camera is attached to the end of GX8 Arm #2 (350 mm from the center of rotation of Joint #2) with a load weight of $W = 2$ kg

$$W = 2$$

$$M = 1$$

$$L_1 = 300$$

$$L_2 = 250$$

$$L_M = 350$$

$$W_M = 1 \times (350 + 300)^2 / (250 + 300)^2 = 1.40 \text{ (Round up to two decimal places)}$$

$$W + W_M = 2 + 1.4 = 3.4$$

Enter "3.4" for the [Hand Weight] parameter.

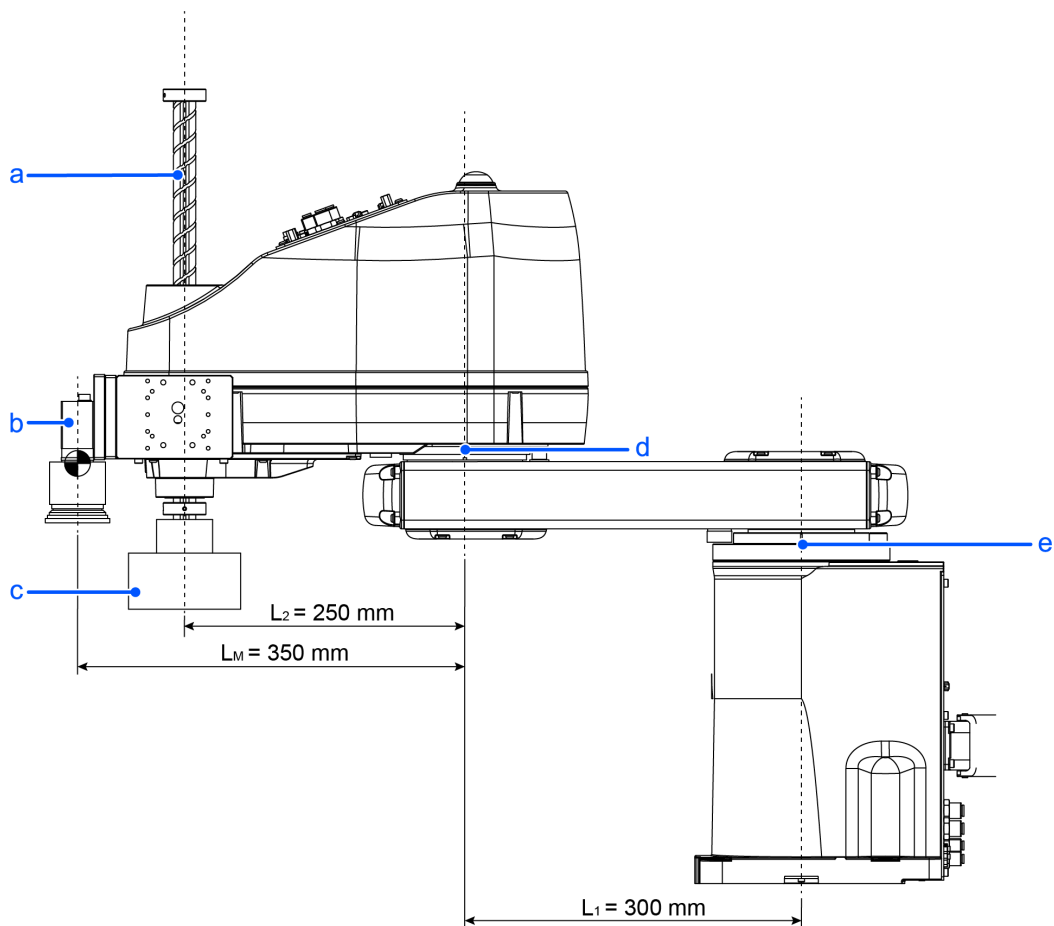

Symbol	Description
a	Shaft
b	Weight of the entire camera $M = 1 \text{ kg}$
c	$W = 2 \text{ kg}$
d	Joint #2
e	Joint #1

3.4.3.1.3 Automatic Speed Correction at Weight Setting

Standard mode

GX8-A/GX8-B/GX8-C45***

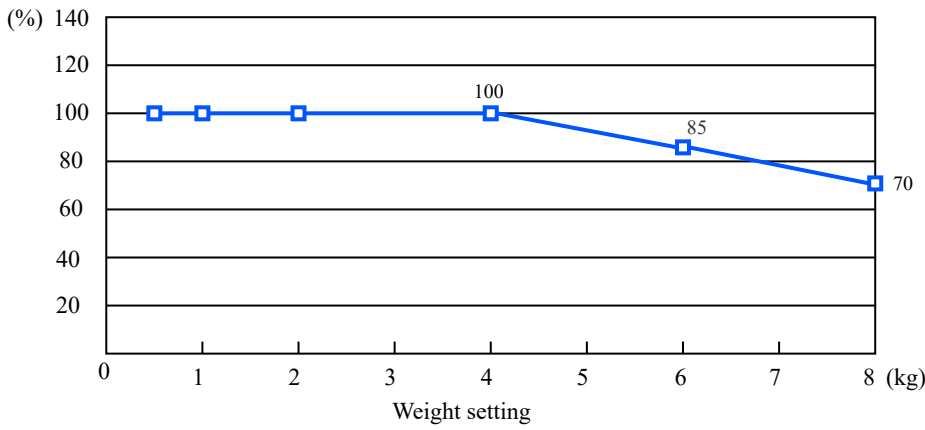

The percentages on the graph are ratios based on 100% as the speed at the rated (4 kg) setting.

GX8-A/GX8-B/GX8-C55***

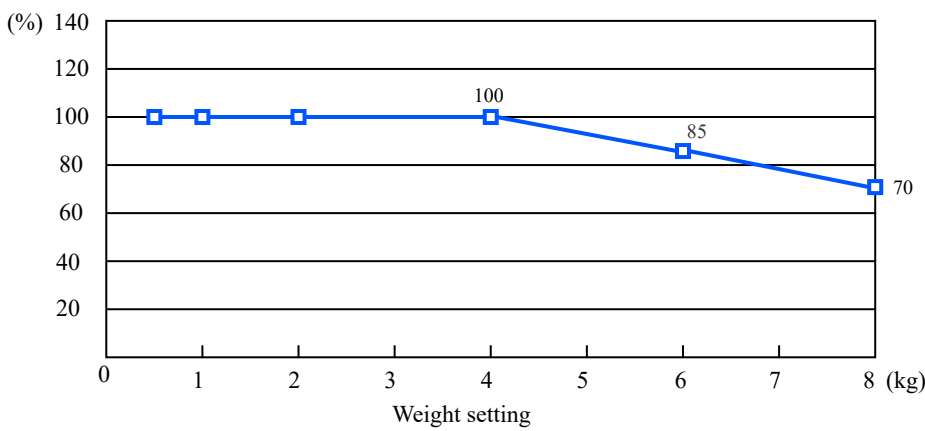

The percentages on the graph are ratios based on 100% as the speed at the rated (4 kg) setting.

GX8-A/GX8-B/GX8-C65***

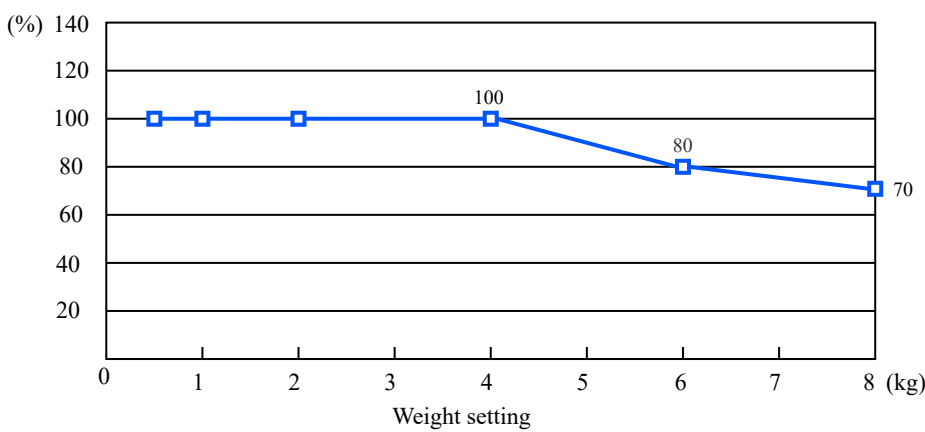

The percentages on the graph are ratios based on 100% as the speed at the rated (4 kg) setting.

Boost mode

GX8-A/GX8-B/GX8-C45***

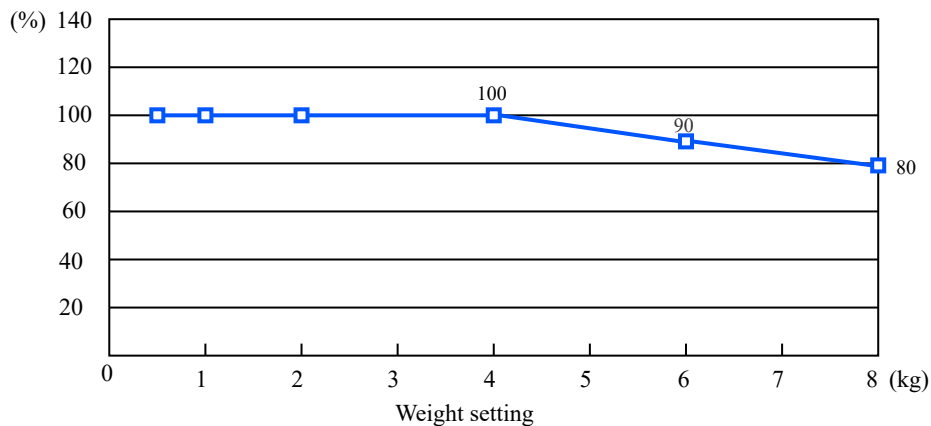

The percentages on the graph are ratios based on 100% as the speed at the rated (4 kg) setting.

GX8-A/GX8-B/GX8-C55***

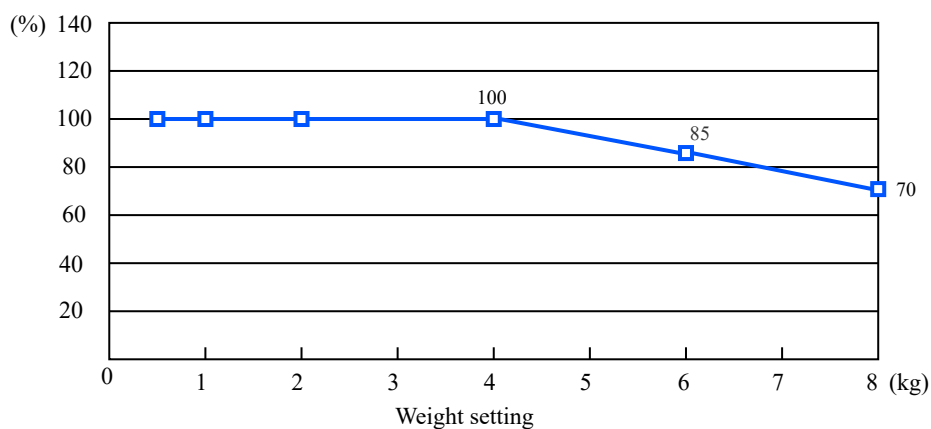

The percentages on the graph are ratios based on 100% as the speed at the rated (4 kg) setting.

GX8-A/GX8-B/GX8-C65***

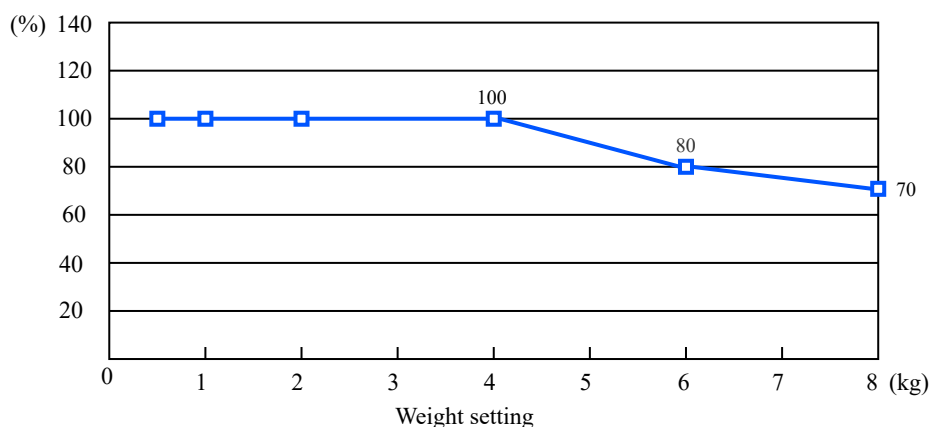

The percentages on the graph are ratios based on 100% as the speed at the rated (4 kg) setting.

3.4.3.1.4 Automatic Acceleration/Deceleration Correction at Weight Setting

Standard mode

GX8-A/GX8-B/GX8-C45***

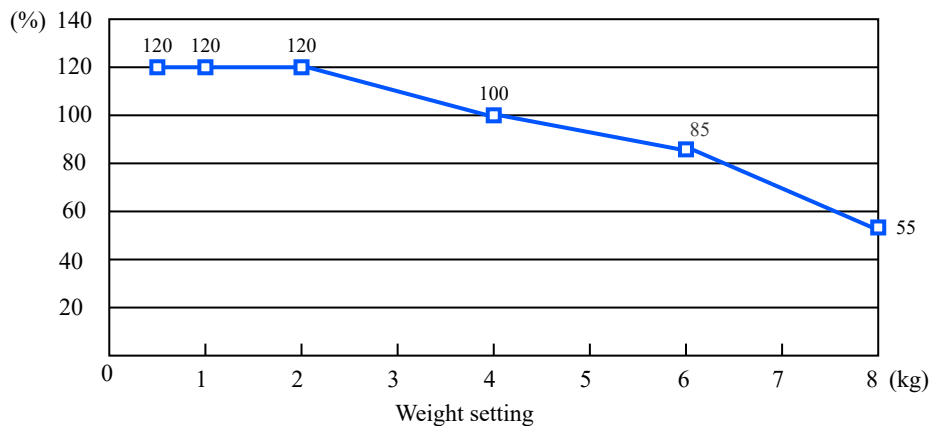

The percentages on the graph are ratios based on 100% as the acceleration/deceleration at the rated (4 kg) setting.

GX8-A/GX8-B/GX8-C55***

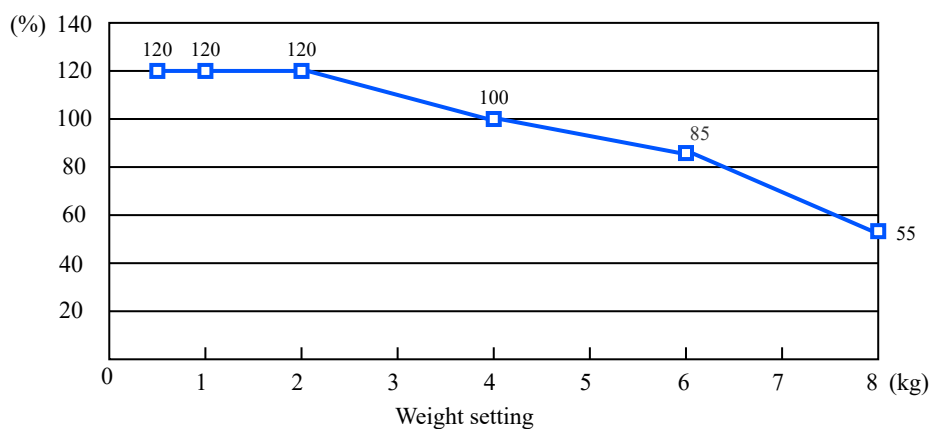

The percentages on the graph are ratios based on 100% as the acceleration/deceleration at the rated (4 kg) setting.

GX8-A/GX8-B/GX8-C65***

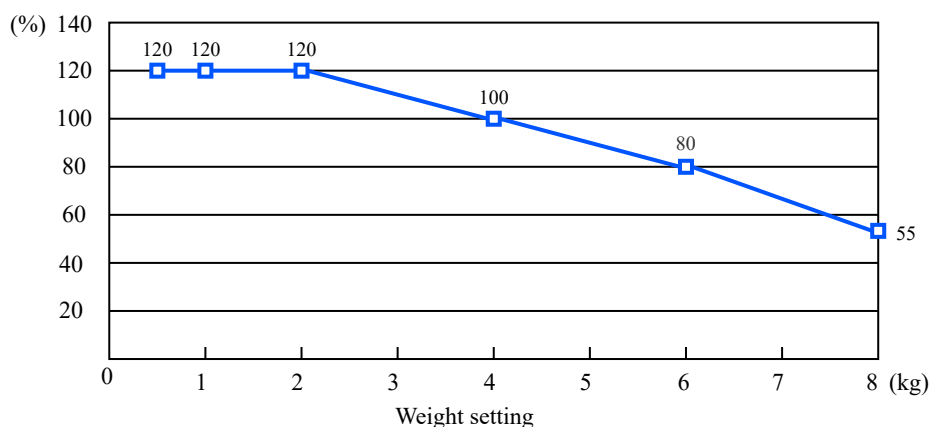

The percentages on the graph are ratios based on 100% as the acceleration/deceleration at the rated (4 kg) setting.

Boost mode

GX8-A/GX8-B/GX8-C45***

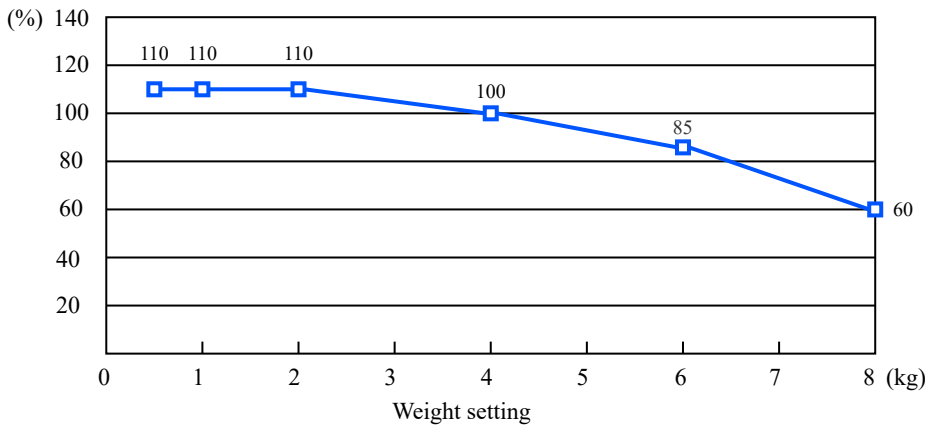

The percentages on the graph are ratios based on 100% as the acceleration/deceleration at the rated (4 kg) setting.

GX8-A/GX8-B/GX8-C55***

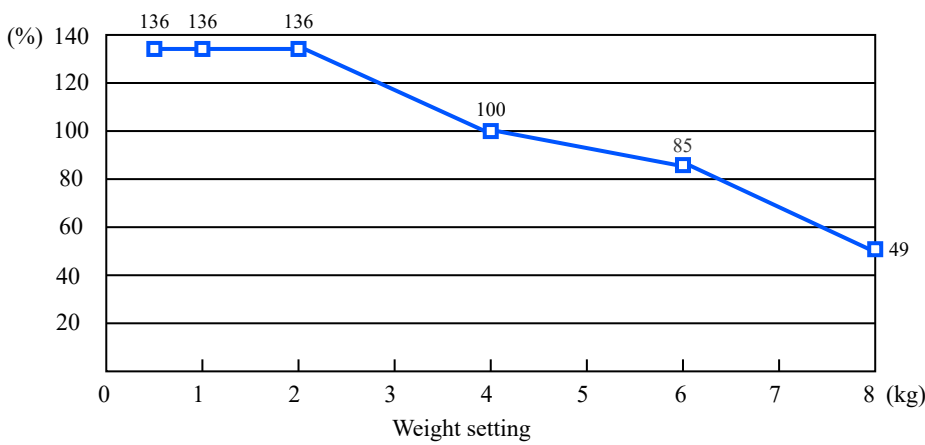

The percentages on the graph are ratios based on 100% as the acceleration/deceleration at the rated (4 kg) setting.

GX8-A/GX8-B/GX8-C65***

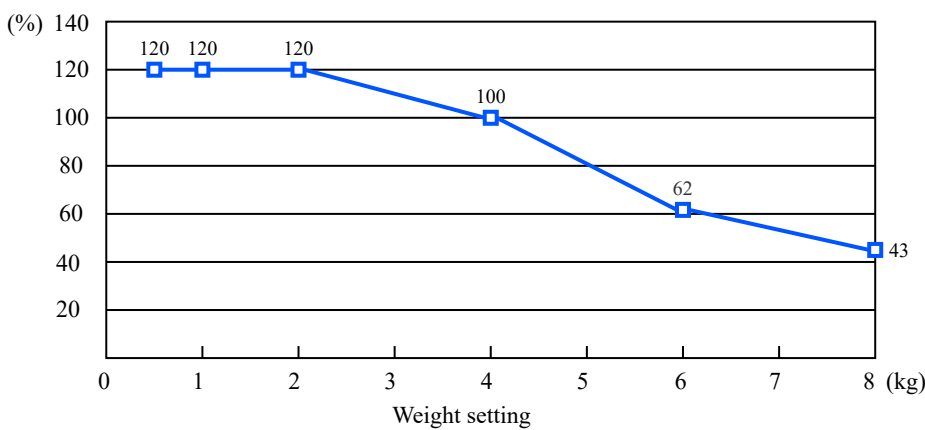

The percentages on the graph are ratios based on 100% as the acceleration/deceleration at the rated (4 kg) setting.

3.4.3.2 Inertia Setting

3.4.3.2.1 Moment of Inertia and Inertia Setting

The moment of inertia is a quantity that expresses how hard it is for an object to turn, and it is expressed in terms of values for

the moment of inertia, inertia, or GD^2 . When a hand or other object is attached to a shaft for operation, the moment of inertia of the load must be taken into consideration.

⚠ CAUTION

- The moment of inertia of the load (weight of the hand and workpiece) must be $0.16 \text{ kg}\cdot\text{m}^2$ or less. The GX8 series Manipulators are not designed to work with a moment of inertia exceeding $0.16 \text{ kg}\cdot\text{m}^2$. Always set the value corresponding to the moment of inertia. Setting a parameter value that is smaller than the actual moment of inertia may cause errors or impact, may prevent the Manipulator from working at full functionality, and may shorten the lifespan of mechanical parts.

The allowable moment of inertia of a load for GX8 series Manipulators is $0.01 \text{ kg}\cdot\text{m}^2$ at the default rating and $0.16 \text{ kg}\cdot\text{m}^2$ at the maximum. Depending on the moment of inertia, change the setting of the moment of inertia parameter for the load in the Inertia statement. After the setting is changed, the maximum acceleration/deceleration of Joint #4 during PTP motion that corresponds to the "Inertia" value is corrected automatically.

3.4.3.2.2 Moment of Inertia of Load Attached to Shaft

The moment of inertia of the load (hand + workpiece) attached to the shaft can be set by the "Inertia" parameter in the Inertia statement.

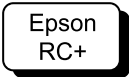

Go to [Tools] - [Robot Manager] - [Inertia] panel, and enter the value in [Inertia]. This can also be set using the Inertia statement in [Command Window].

3.4.3.2.3 Automatic Acceleration/Deceleration Correction of Joint #4 at Inertia (Moment of Inertia) Setting

Standard mode, boost mode

GX8-A/GX8-B/GX8-C45***, GX8-A/GX8-B/GX8-C55***, GX8-A/GX8-B/GX8-C65***

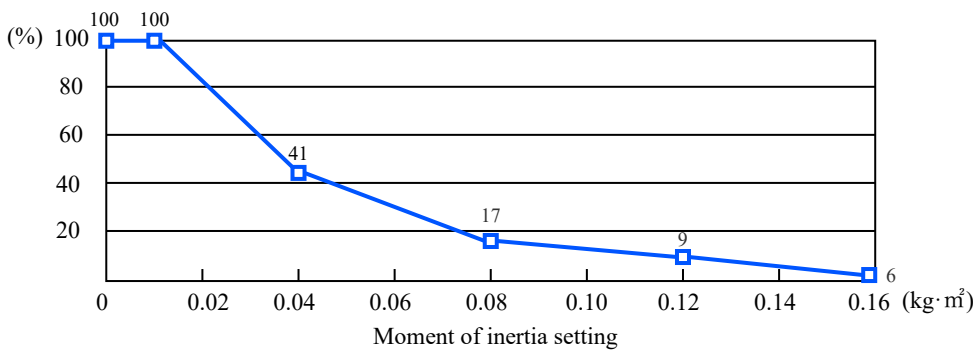

The percentages on the graph are ratios based on 100% as the acceleration/deceleration at the rated ($0.01 \text{ kg}\cdot\text{m}^2$) setting.

3.4.3.2.4 Eccentricity and Inertia Setting

⚠ CAUTION

- The eccentricity of the load (hand and workpiece) must be 150 mm or less. The GX8 series Manipulators are not designed to work with eccentricities exceeding 150 mm. Always set the value based on the eccentricity. Setting the eccentricity parameter to a value smaller than the actual eccentricity may cause errors or impact that not only impair full functionality but also shorten the life of the mechanical components.

The allowable eccentricity of load for GX8 series Manipulators is 0 mm at the default rating and 150 mm at the maximum. Depending on the load eccentricity, change the setting for the eccentricity parameter in Inertia statement. After the setting is changed, the maximum acceleration/deceleration of the Manipulator during PTP motion that corresponds to the "Eccentricity" is corrected automatically.

Eccentricity

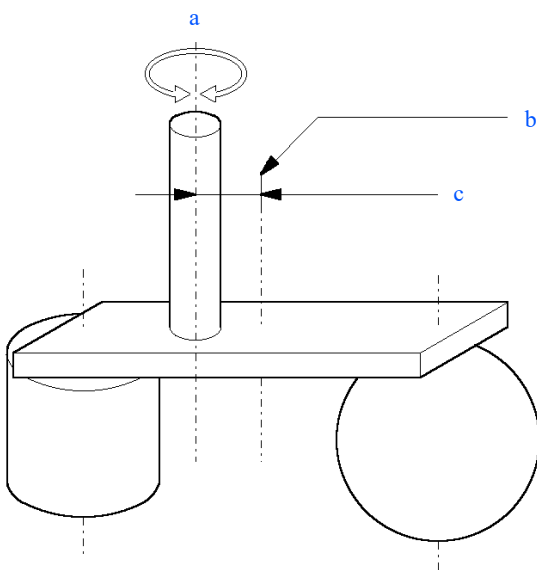

Symbol	Description
a	Rotation axis
b	Load center of gravity position
c	Eccentricity (150 mm or less)

3.4.3.2.5 Eccentricity of Load Attached to Shaft

The eccentricity of the load (hand + workpiece) attached to the shaft can be set by the "Eccentricity" parameter in the Inertia statement.

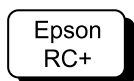

Go to [Tools] - [Robot Manager] - [Inertia] panel, and enter the value in [Eccentricity]. This can also be set using the Inertia statement in [Command Window].

3.4.3.2.6 Automatic Acceleration/Deceleration Correction at Inertia (Eccentricity) Setting

Standard mode, boost mode

GX8-A/GX8-B/GX8-C45***, GX8-A/GX8-B/GX8-C55***, GX8-A/GX8-B/GX8-C65***

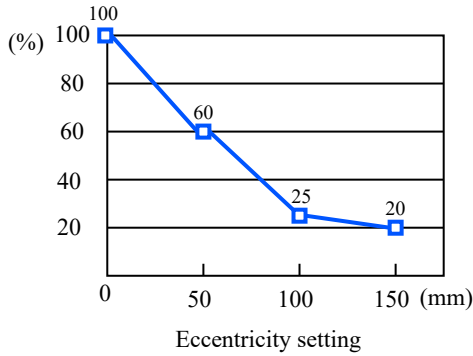

The percentages on the graph are ratios based on 100% as the acceleration/deceleration at the 0 mm setting.

3.4.3.2.7 Calculating the Moment of Inertia

An example of calculating the moment of inertia of a load (hand holding a workpiece) is shown below.

The moment of inertia of the entire load is calculated by the sum of (a), (b), and (c).

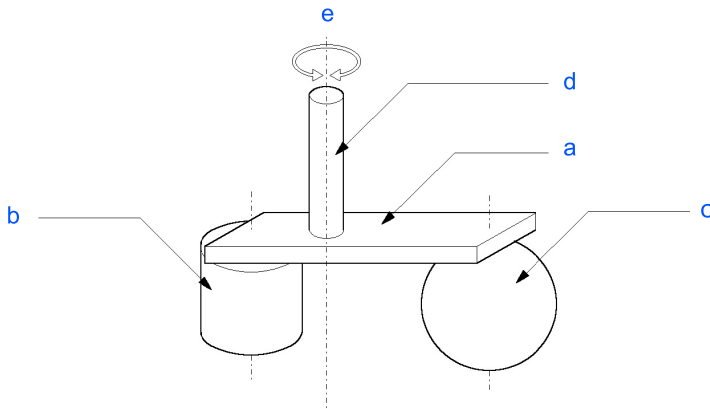

Whole moment of inertia	=	Moment of inertia of end effector (a)	+	Moment of inertia of work piece (b)	+	Moment of inertia of work piece (c)
-------------------------	---	---------------------------------------	---	-------------------------------------	---	-------------------------------------

Symbol	Description
a	Hand
b	Workpiece
c	Workpiece
d	Shaft
e	Rotation axis

The methods for calculating the moment of inertia for (a), (b), and (c) are shown below. Use the moment of inertia of these basic shapes as a reference to find the moment of inertia of the entire load.

(a) Moment of inertia of a rectangular parallelepiped

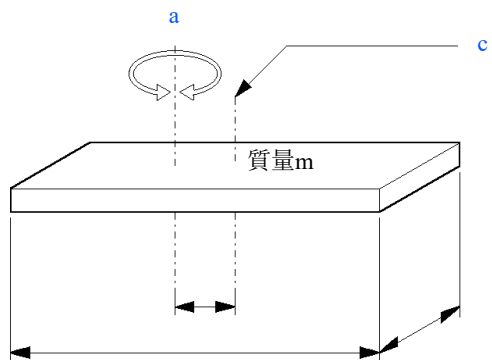

$$m \frac{b^2+h^2}{12} + m \times L^2$$

Symbol	Description
a	Rotation axis
c	Center of gravity of rectangular parallelepiped

(b) Moment of inertia of a cylinder

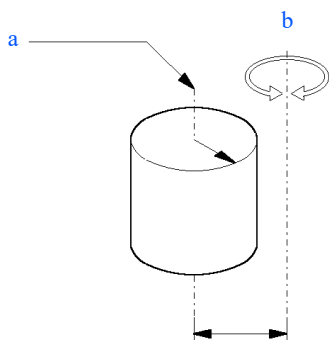

$$m \frac{r^2}{2} + m \times L^2$$

Symbol	Description
a	Center of gravity of cylinder
b	Rotation axis

(c) Moment of inertia of a sphere

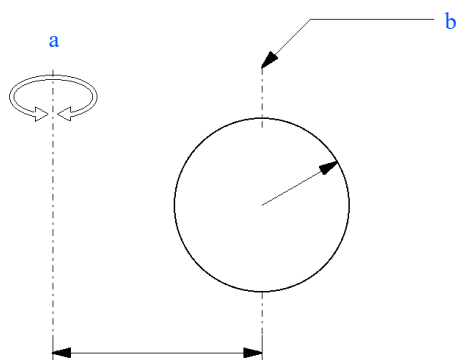

$$m \frac{2}{5} r^2 + m \times L^2$$

Symbol	Description
a	Rotation axis
b	Center of gravity of sphere

3.4.4 Safety Information for Auto Acceleration of Joint #3

When performing horizontal movement in PTP motion, the operation time can be shorted by setting the shaft to a high position.

When performing horizontal movement in PTP motion, if the shaft height is less than a certain value, the auto acceleration function is activated, and the acceleration/deceleration of the movement is set slower for lower shaft heights. A higher shaft position results in a faster acceleration/deceleration for the movement, but the up movement time and down movement time of the shaft are also required. Adjust the shaft height by taking into consideration the positional relationship between the current position and the target position.

The shaft height at the time of horizontal movement for the Jump statement can be set by the LimZ statement.

3.4.4.1 Automatic Acceleration/Deceleration Correction by Shaft Position

Standard mode

GX8-A/GX8-B/GX8-C45***

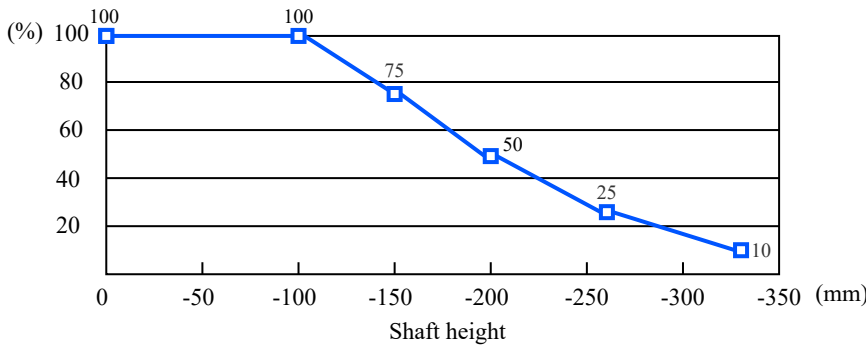

The percentages on the graph are ratios based on 100% as the acceleration/deceleration at the shaft upper limit position.

GX8-A/GX8-B/GX8-C55***

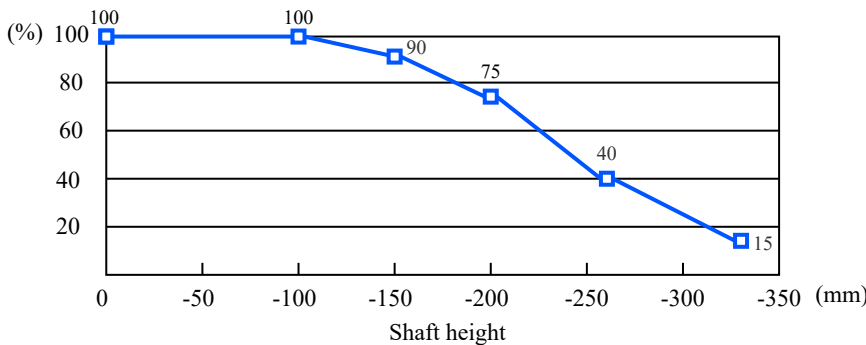

The percentages on the graph are ratios based on 100% as the acceleration/deceleration at the shaft upper limit position.

GX8-A/GX8-B/GX8-C65***

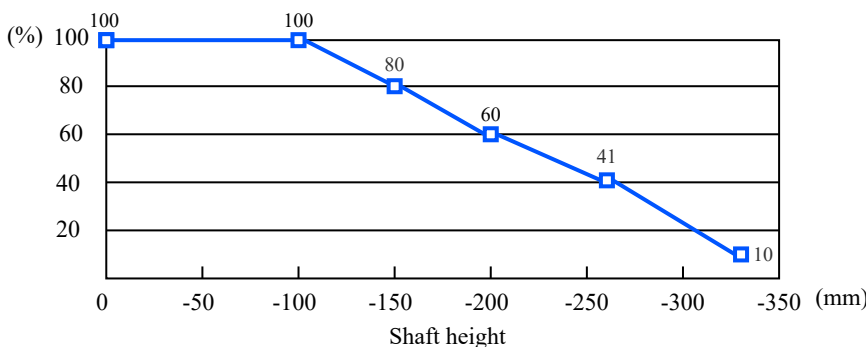

The percentages on the graph are ratios based on 100% as the acceleration/deceleration at the shaft upper limit position.

Boost mode

GX8-A/GX8-B/GX8-C45***

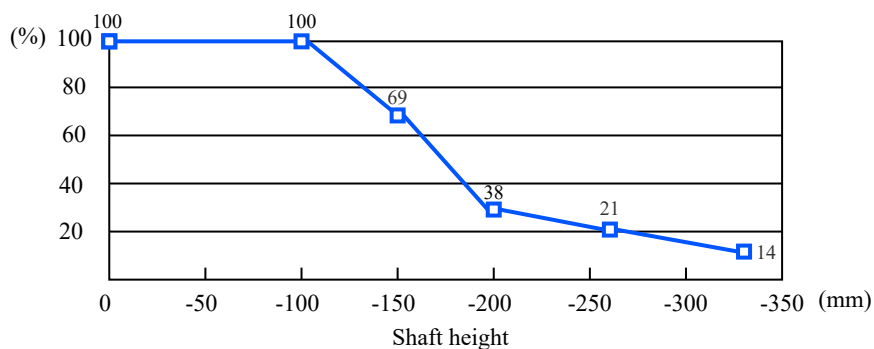

The percentages on the graph are ratios based on 100% as the acceleration/deceleration at the shaft upper limit position.

GX8-A/GX8-B/GX8-C55***

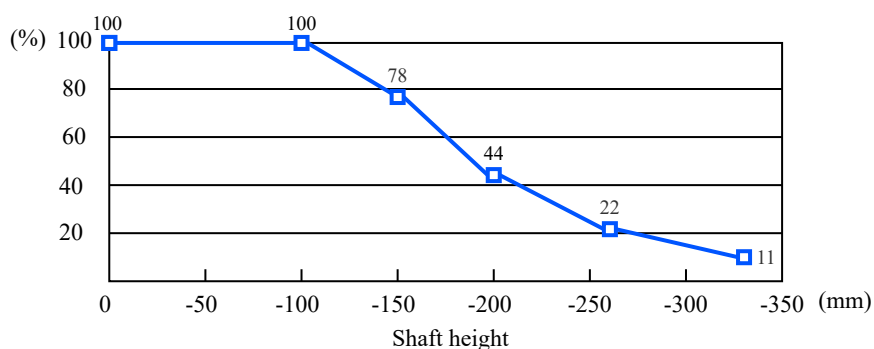

The percentages on the graph are ratios based on 100% as the acceleration/deceleration at the shaft upper limit position.

GX8-A/GX8-B/GX8-C65***

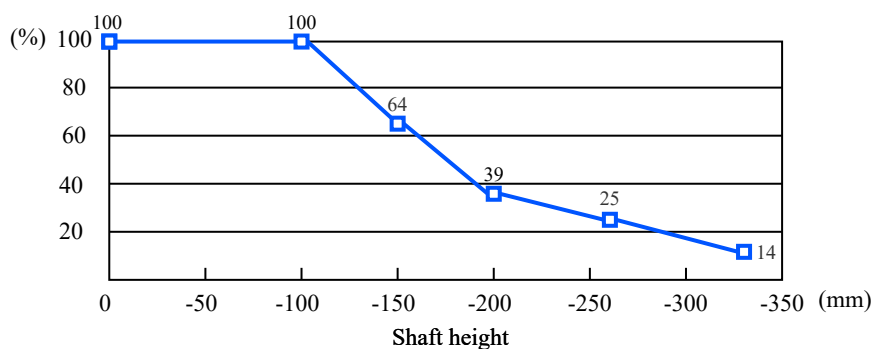

The percentages on the graph are ratios based on 100% as the acceleration/deceleration at the shaft upper limit position.

KEY POINTS

Horizontal movement with the shaft lowered may cause overshooting during positioning.

3.5 Work Envelope

⚠ WARNING

- Do not operate the Manipulator with the mechanical stop removed. Removing the mechanical stop is extremely dangerous because the Manipulator may move to a position outside its normal work envelope.

⚠ CAUTION

- When restricting the work envelope for safety reasons, be sure to make settings using both the pulse range and mechanical stop.

The work envelope is preset at the factory as explained in the following section.

Standard Work Envelope

The work envelope can be set by one of the following three methods.

- Setting by pulse range (for all joints)
- Setting by mechanical stops (for Joints #1 to #3)
- Setting the rectangular range in the XY coordinate system of the Manipulator (for Joints #1 and #2)

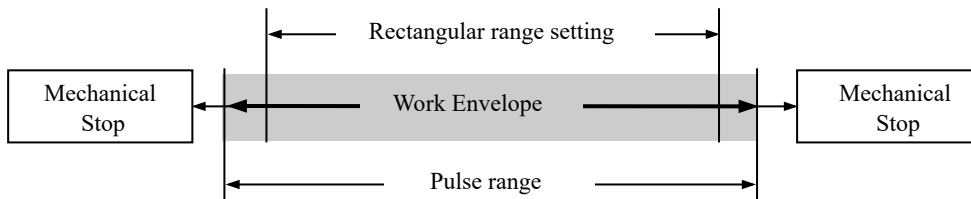

To limit the work envelope for layout efficiency or safety reasons, make the settings as explained in the following sections.

Work Envelope Setting by Pulse Range

Setting the Work Envelope by Mechanical Stops

Setting the Rectangular Range in the XY Coordinate System of the Manipulator

3.5.1 Work Envelope Setting by Pulse Range

Pulses are the basic unit of Manipulator motion. The motion range (work envelope) of the Manipulator is set by the pulse lower limit value and pulse upper limit value (pulse range) for each joint.

Pulse values are read from the encoder output of the servomotor.

For the maximum pulse range, refer to the following sections.

The pulse range must be set within the mechanical stop range.

Joint #1 Maximum Pulse Range

Joint #2 Maximum Pulse Range

Joint #3 Maximum Pulse Range

Joint #4 Maximum Pulse Range

✎ KEY POINTS

Once the Manipulator receives an operation command, it checks whether the target position specified by the command is within the pulse range before operating. If the target position is outside of the pulse range that was set, an error occurs and the Manipulator does not move.

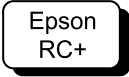

Go to [Tools] - [Robot Manager] - [Range] panel, and make the setting.
 This can also be set using the Range statement in [Command Window].

3.5.1.1 Joint #1 Maximum Pulse Range

The 0 (zero) pulse position of Joint #1 is the position where Arm #1 is facing the positive (+) direction on the X-coordinate axis.

With the 0 pulse as a starting point, the counterclockwise pulse value is defined as positive (+), and the clockwise pulse value is defined as negative (-).

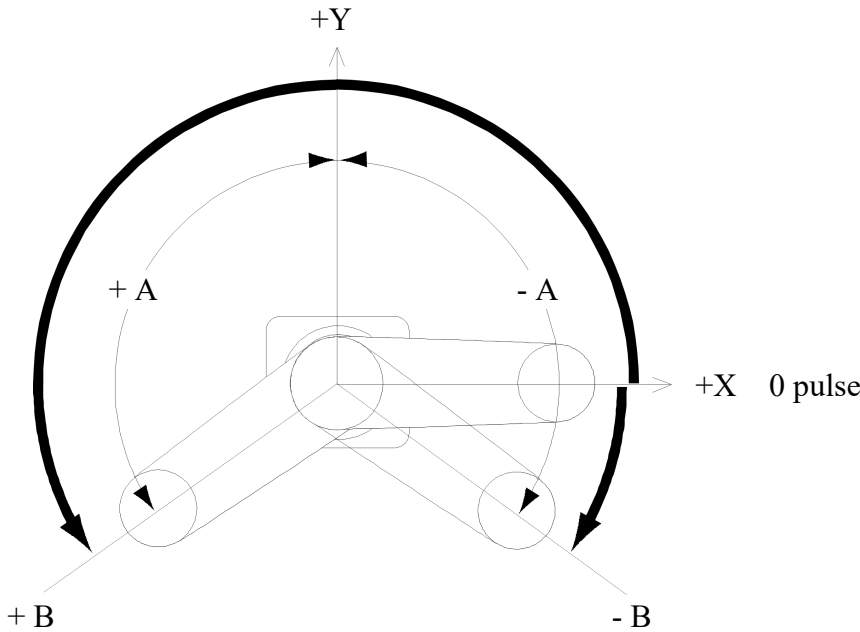

	Arm Length (mm)	Mounting Specifications		
		Table Top	Ceiling	Wall
A: Max. motion range (deg.)	450	±152	±105	±105
	550		±152	±135
	650			±148
B: Max. pulse range (pulse)	450	-1128676 to +4405476	273067 to +3549867	-273067 to +3549867
	550		-1128676 to +4405476	-819200 to +4096000
	650			-1055858 to +4332658

3.5.1.2 Joint #2 Maximum Pulse Range

The 0 (zero) pulse position of Joint #2 is the position where Arm #2 is aligned with Arm #1. (The orientation of Arm #1 does not matter.)

With the 0 pulse as a starting point, the counterclockwise pulse value is defined as positive (+), and the clockwise pulse value is defined as negative (-).

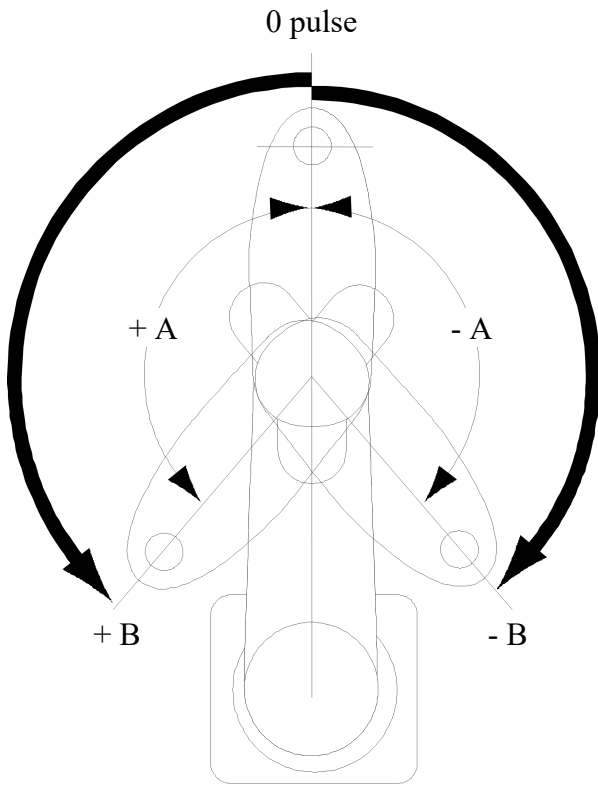

	Arm Length (mm)	Environmental Specifications	Z-value Range (mm)	Mounting Specifications		
				Table Top	Ceiling	Wall
A: Max. motion range (deg.)	450	S, E	$0 \geq Z \geq -270$	±147.5	±125	
			$-270 > Z \geq -330$	±145		
		C, P	$0 \geq Z \geq -240$	±147.5		
			$-240 > Z \geq -300$	±137.5		
	550	S, E	-	±147.5		
		C, P	$0 \geq Z \geq -240$	±147.5	±145	
$-240 > Z \geq -300$	±145					
650	S, E, C, P	-	±147.5			
B: Max. pulse range (pulse)	450	S, E	$0 \geq Z \geq -270$	±2685156	±2275556	
			$-270 > Z \geq -330$	±2639644		
		C, P	$0 \geq Z \geq -240$	±2685156		
			$-240 > Z \geq -330$	±2503111		
	550	S, E	-	±2685156		
		C, P	$0 \geq Z \geq -240$	±2685156	±2639644	

	Arm Length (mm)	Environmental Specifications	Z-value Range (mm)	Mounting Specifications		
				Table Top	Ceiling	Wall
			$-240 > Z \geq -300$	±2639644		
	650	S, E, C, P	-	±2685156		

3.5.1.3 Joint #3 Maximum Pulse Range

The 0 (zero) pulse position of Joint #3 is the position where the shaft is at its upper limit. The pulse value is always negative because Joint #3 moves down from the 0 pulse position.

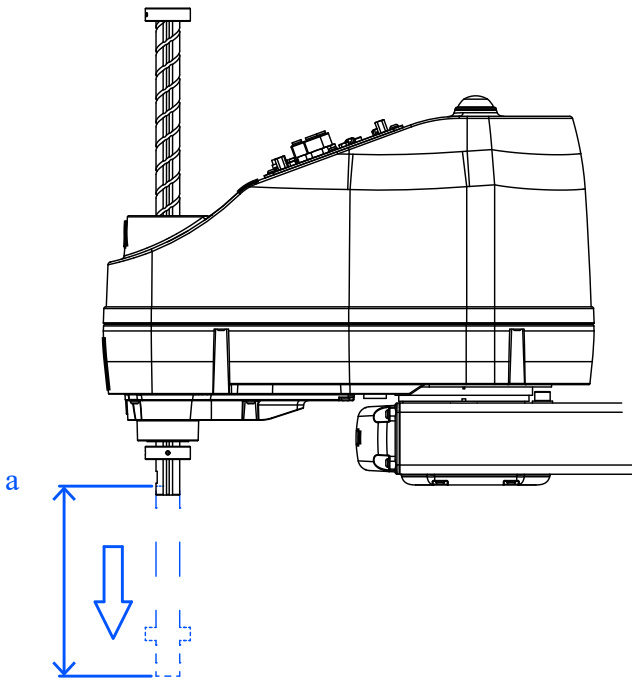

Symbol	Description
a	Upper limit: 0 pulse

	Joint #3 Stroke Code	Environmental Specifications		
		S, E	C	P
Max. motion range (mm)	2	-200 to 0	-170 to 0	
	3	-330 to 0	-300 to 0	
Max. pulse range (pulse)	2	-1092267 to 0	-928427 to 0	
	3	-1802240 to 0	-1638400 to 0	

KEY POINTS

For Manipulator models with cleanroom & ESD specifications and with protected-model, the work envelope set by the Joint #3 mechanical stop cannot be changed.

3.5.1.4 Joint #4 Maximum Pulse Range

The 0 (zero) pulse position of Joint #4 is the position where the flat surface near the end of the shaft faces toward the end of Arm #2. (The orientation of Arm #2 does not matter.)

With the 0 pulse as a starting point, the counterclockwise pulse value is defined as positive (+), and the clockwise pulse value is defined as negative (-).

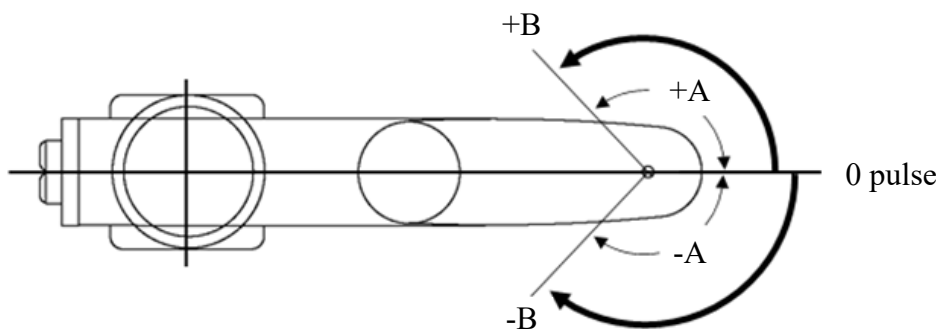

	All Models
A: Max. motion range (deg.)	±360
B: Max. pulse range (pulse)	±1668189

3.5.2 Setting the Work Envelope by Mechanical Stops

Mechanical stops set the absolute work envelope that physically limits where the Manipulator can move. Both Joints #1 and #2 have threaded holes in positions corresponding to angles for the setting area. The positions of the mechanical stops (variable) set the work envelope. Install the bolts in the threaded holes corresponding to the angles to be set. Joint #3 can be set to any length less than the maximum stroke.

Table top mounting specifications

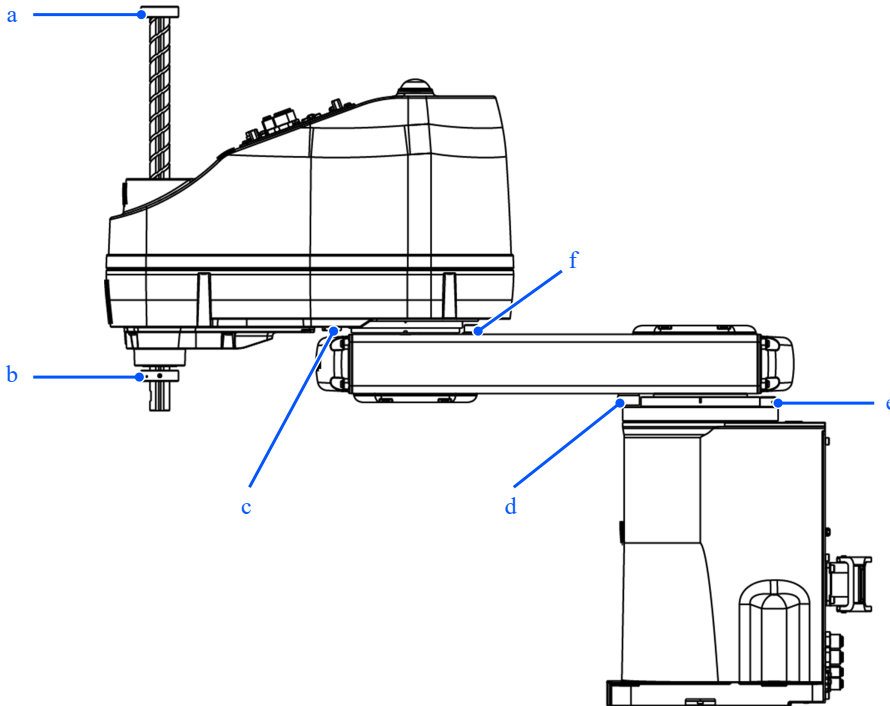

Symbol	Description
a	Joint #3 mechanical stop (lower limit mechanical stop)
b	Joint #3 mechanical stop (upper limit mechanical stop) *Do not move the position.
c	Joint #2 mechanical stop (variable)
d	Joint #1 mechanical stop (fixed)
e	Joint #1 mechanical stop (variable)
f	Joint #2 mechanical stop (fixed)

Wall mounting specifications

Only the stop positions that are different from the model with table top mounting specifications are explained here.

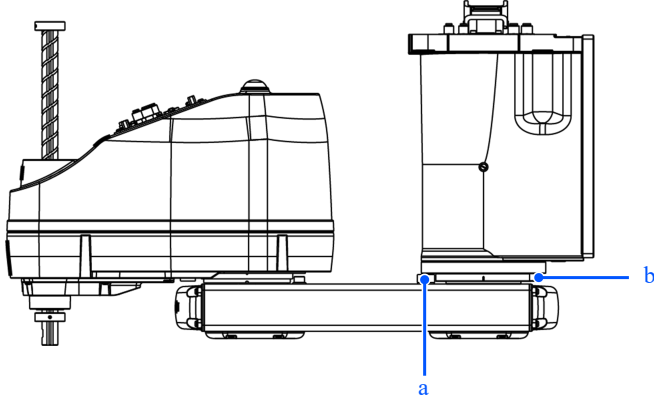

Symbol	Description
a	Joint #1 mechanical stop (fixed)
b	Joint #1 mechanical stop (variable)

Ceiling mounting specifications

Only the stop positions that are different from the model with table top mounting specifications are explained here.

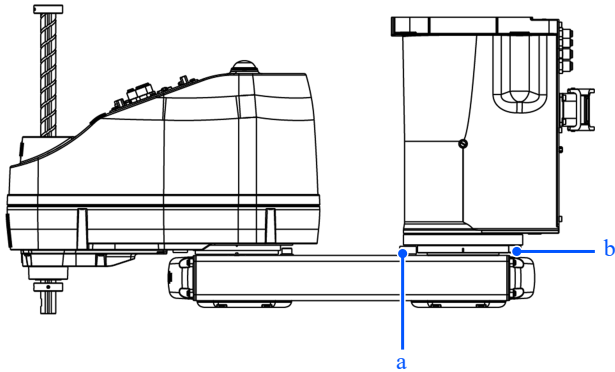

Symbol	Description
a	Joint #1 mechanical stop (fixed)
b	Joint #1 mechanical stop (variable)

3.5.2.1 Setting the Mechanical Stops of Joints #1 and #2

Both Joints #1 and #2 have threaded holes in positions corresponding to angles for the setting area. The positions of the mechanical stops (variable) set the work envelope.

Use the following procedure to install the bolts in the holes corresponding to the angle that you want to set.

1. Turn off the Controller.
2. Install a hexagon socket head cap bolt into the threaded hole corresponding to the setting angle, and tighten it.

Joint #	Hexagon Socket Head Cap Bolt	Number of Bolts	Recommended Tightening Torque	Strength
1	M10 × 20 full thread	1 for each side	18.0 N·m (194 kgf·cm)	ISO 898-1 property class 10.9 or 12.9 equivalent
2	M8 × 10 full thread			

3. Turn on the Controller.

4. Set the pulse range corresponding to the new positions of the mechanical stops.

KEY POINTS

Be sure to set the pulse range inside the positions of the mechanical stop range.

Example: Setting Joint #1 to -135° to +135° and Joint #2 to -125° to +125° for the GX8-A2S***

Epson
RC+

Execute the following command in [Command Window].

```
>JRANGE 1,-819200,4096000 'Sets the pulse range of Joint #1
>JRANGE 2,-2275556,+2275556 'Sets the pulse range of Joint #2
>RANGE 'Confirms the setting value using the Range statement
-819200,4096000,-2275556,2275556,-1092267,0,-1668189, 1668189
```

5. Move the arm by hand until it touches the mechanical stops to check that nothing will hinder the arm motion during operation, such as by hitting peripheral equipment.
6. Operate the joint with the new settings at low speeds until it reaches the positions of the minimum and maximum values of the pulse range. Check that the arm does not hit any mechanical stops.
(Check the position of the mechanical stops and the motion range that were set.)

Example: Setting Joint #1 to -85° to +115° and Joint #2 to -100° to +100° for the GX8-A2S***

Epson
RC+

Execute the following command in [Command Window].

```
>MOTOR ON 'Turns on the motor
>POWER LOW 'Sets to low power mode
>SPEED 5 'Sets to low speed
>PULSE 91022,0,0,0 'Moves to the minimum pulse position of Joint #1
>PULSE 3731912,0,0,0 'Moves to the maximum pulse position of Joint #1
>PULSE 1638400,-1820444,0,0 'Moves to the minimum pulse position of Joint #2
>PULSE 1638400,1820444,0,0 'Moves to the maximum pulse position of Joint #2
```

The Pulse statement (Go Pulse statement) moves all joints to the specified positions at the same time. Set safe positions after taking into consideration the motion of the joints whose pulse range have been changed and also the other joints.

In this example, when checking Joint #2, Joint #1 is moved to the 0° position (pulse value: 1638400) near the center of its work envelope.

If the arm hits a mechanical stop or if an error occurs after the arm hits a mechanical stop, either reset the pulse range to a narrower pulse range so that nothing blocks the arm motion, or extend the positions of the mechanical stops within the limit.

Joint #1 mechanical stop

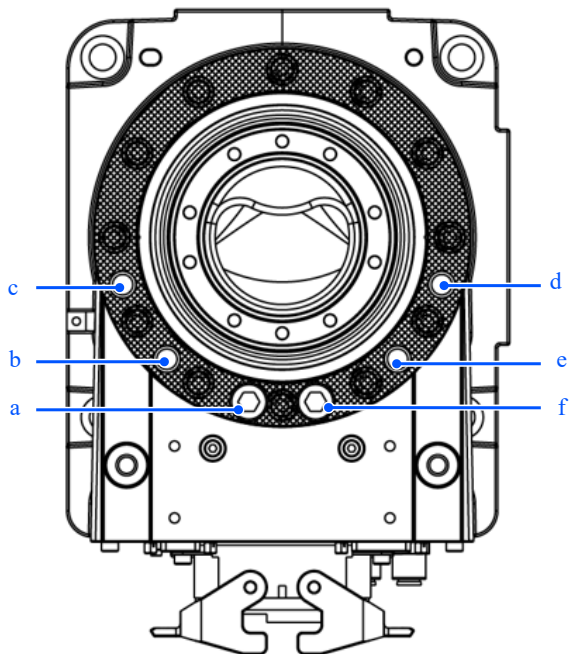

	Mounting Specifications	Arm Length (mm)	a	b	c	d	e	f
Max. motion range (deg.)	Table top	450, 550, 650	152°	135°	115°	-115°	-135°	-152°
	Ceiling	450	-	105°	85°	-85°	-105°	-
		550, 650	152°	135°	115°	-115°	-135°	-152°
	Wall	450	-	105°	85°	-85°	-105°	-
		650	148°	135°	115°	-115°	-135°	-148°
Max. pulse range (pulse)	Table top	450, 550, 650	4405476	4096000	3731912	-455111	-819200	-1128676
	Ceiling	450	-	3549867	3185778	91022	-273067	-
		550, 650	4405476	4096000	3731912	-455111	-819200	-1128676
	Wall	450	-	3549867	3185778	91022	-273067	-
		650	4332658	4096000	3731912	-455111	-819200	-1055858

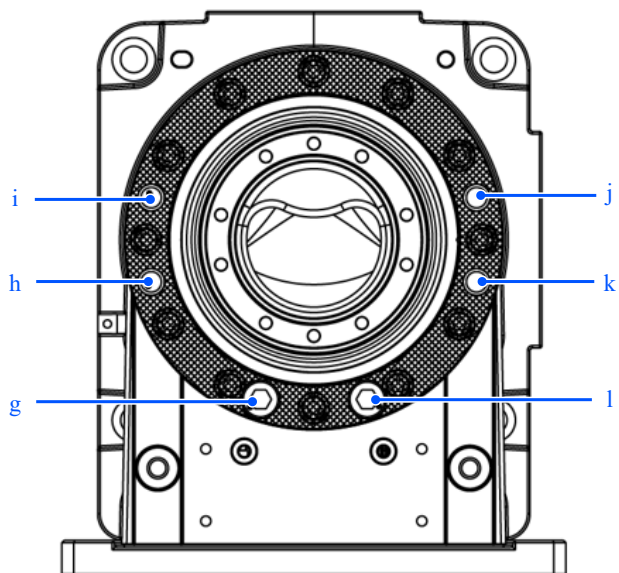

GX8-*55**W only

	Mounting Specifications	Arm Length (mm)	g	h	i	j	k	l
Max. motion range (deg.)	Wall	550	135	85	55	-55	-85	-135
Max. pulse range (pulse)			4096000	3185778	2639645	637156	91022	-819200

Joint #2 mechanical stop

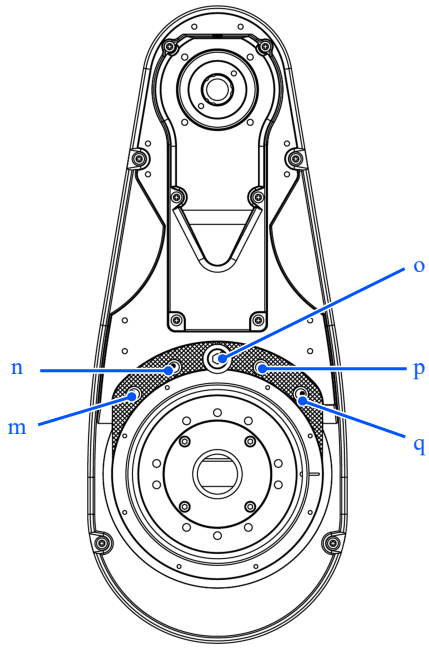

Max. motion range (deg.):

Arm Length (mm)	Mounting Specifications	Environmental Specifications	Z-value Range (mm)	m	n	o	p	q
450	Table top	S, E	$0 \geq Z \geq -270$	+100	+125	± 147.5	-125	-100
			$-270 > Z \geq -330$			± 145		
		C, P	$0 \geq Z \geq -240$			± 147.5		
			$-240 > Z \geq -300$			± 137.5		
	Ceiling	S, E, C, P	-	+79	+103	± 125	-103	-79
Wall	-		-	-	-	-	-	
550	Table top	S, E	-	+100	+125	± 147.5	-125	-100
			C, P			$0 \geq Z \geq -240$		
		$-240 > Z \geq -300$				± 145		
	Ceiling	S, E	-			± 147.5		
		C, P	-			± 145		
	Wall	S, E	-			± 147.5		
		C, P	-			± 145		
650	Table top	S, E, C, P	-	-	-	± 147.5	-	-
	Ceiling		-	-	-	± 147.5	-	-
	Wall		-	-	-	± 147.5	-	-

Max. pulse range (pulse):

Arm Length (mm)	Mounting Specifications	Environmental Specifications	Z-value Range (mm)	m	n	o	p	q
450	Table top	S, E	$0 \geq Z \geq -270$	+1820444	+2275556	±2685156	-2275556	-1820444
			$-270 > Z \geq -330$			±2639644		
		C, P	$0 \geq Z \geq -240$			±2685156		
			$-240 > Z \geq -300$			±2503111		
	Ceiling	S, E, C, P	-	+1438151	+1875058	±2275556	-1875058	-1438151
Wall								
550	Table top	S, E	-	+1820444	+2275556	±2685156	-2275556	-1820444
			C, P			$0 \geq Z \geq -240$		
		$-240 > Z \geq -300$				±2639644		
	Ceiling	S, E	-			±2685156		
		C, P	-			±2639644		
	Wall	S, E	-			±2685156		
		C, P	-			±2639644		
650	Table top	S, E, C, P	-			±2685156		
	Ceiling							
	Wall							

3.5.2.2 Setting the Mechanical Stop of Joint #3

 **KEY POINTS**

This method can be used only for the Manipulator models with standard specifications (GX8-****S*) and ESD specifications (GX8-****E*).

For Manipulator models with cleanroom & ESD specifications (GX8-****C*) and protected-model (GX8-****P*), the work envelope set by the Joint #3 mechanical stop cannot be changed.

1. Turn on the Controller, and turn off the motors using the Motor OFF statement.

2. Push up the shaft while pressing the brake release switch.

Do not push the shaft up to its upper limit or it will be difficult for the arm top cover to be removed. Push the shaft up to a position where the Joint #3 mechanical stop can be changed.

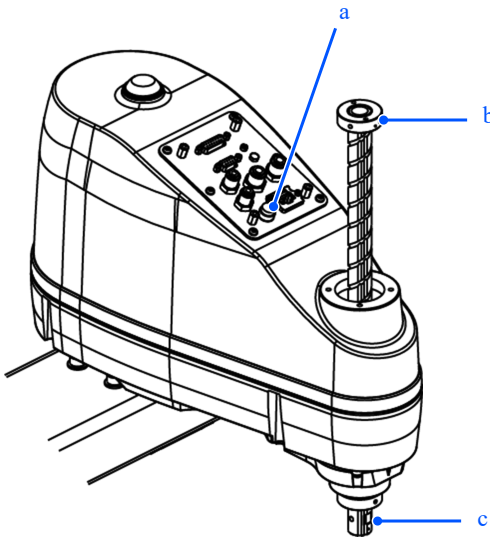

Symbol	Description
a	Brake release switch
b	Lower limit mechanical stop
c	Shaft

KEY POINTS

When you press the brake release switch, the shaft may lower or rotate due to the weight of the hand. Be sure to hold the shaft by hand while pressing the switch.

3. Turn off the Controller.

4. Loosen the low-profile hexagon socket head cap bolts (2 × M5) on the lower limit mechanical stop.

KEY POINTS

A mechanical stop is mounted on both the top and bottom of Joint #3. However, only the position of the lower limit mechanical stop on the top can be changed. Do not remove the upper limit mechanical stop on the bottom because the origin position of Joint #3 is determined by this stop.

5. The upper end of the shaft defines the maximum stroke position. Move the lower limit mechanical stop down by the length that you want to limit the stroke.

For example, when the lower limit mechanical stop is set at the "200 mm" stroke, the lower limit Z coordinate value is "-200". To change this value to "-150", move the lower limit mechanical stop down by "50 mm". Use calipers or similar tool to measure the distance when adjusting the mechanical stop.

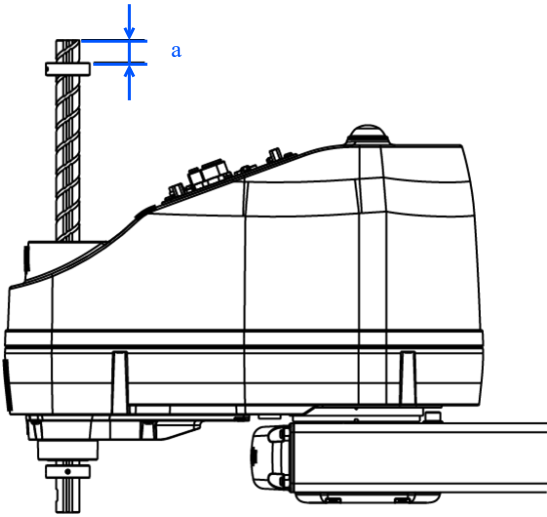

Symbol	Description
a	Measurement length

- Adjust the low-profile hexagon socket head cap bolts (2 × M5) of the lower limit mechanical stop so that the size of the gap between the two is about the same, and secure in place at the following torque.
Recommended tightening torque: 8.0 ± 0.4 N·m (82 ± 4 kgf·cm)

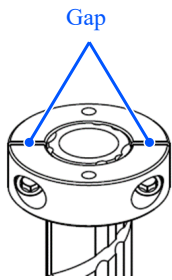

- Turn on the Controller.
- Press down Joint #3 while pressing the brake release switch, and then check the lower limit position. Do not lower the mechanical stop too far. Otherwise, the joint may not reach a target position.
- Calculate the lower limit pulse value of the pulse range using the formula shown below, and set the value.
The result of the calculation is always negative because the lower limit Z coordinate value is negative.

GX8-*2S (Z: -200 mm): Lower limit of pulse = (lower limit Z coordinate value)/40 × 131072 × (60/36)**
GX8-*3S (Z: -330 mm): Lower limit of pulse = (lower limit Z coordinate value)/40 × 131072 × (60/36)**

Example: To lower the mechanical stop by 50 mm and change the lower limit Z coordinate value to "-150" with a 200 mm stroke

$$(-150)/40 \times 131072 \times (60/36) = -819200$$

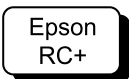

Execute the following command in [Command Window].

```
>JRANGE 3, -819200, 0 'Sets the pulse range of Joint #3
```

- Using the Pulse statement (Go Pulse statement), move Joint #3 to the lower limit position of the pulse range that was set at low speed.

If the mechanical stop range is less than the pulse range, Joint #3 will hit the mechanical stop and an error will occur. When an error occurs, either change the pulse range to a narrower setting or extend the position of the mechanical stop within the limit.

Example: To lower the mechanical stop by 50 mm and change the lower limit Z coordinate value to "-150" with a 200 mm stroke

Epson
RC+

Execute the following command in [Command Window].

```
>MOTOR ON           'Turns on the motor
>SPEED 5           'Sets to low speed
>PULSE 0,0,-819200,0 'Moves to the lower limit pulse position of Joint #3
```

(In this example, all pulses except those for Joint #3 are "0". Substitute these "0" values with the other pulse values to specify a position where interference will not occur even when lowering Joint #3.)

3.5.3 Setting the Rectangular Range in the XY Coordinate System of the Manipulator

(For Joints #1 and #2)

Use this procedure to set the upper and lower limits of the X and Y coordinates.

This setting is a software-based limit only, and so it does not change the maximum physical range. The maximum physical range is based on the position of the mechanical stops.

Epson
RC+

Go to [Tools] - [Robot Manager] - [XYZ Limits] panel, and make the setting.

This can also be set using the XYLim statement in [Command Window].

3.5.4 Standard Work Envelope

The following "work envelope" diagrams show the model with standard (maximum) specifications. When each joint motor is under servo control, the center of the Manipulator shaft's lowest point moves in the ranges shown in the figure.

- Range to mechanical stop
This is the range where the center of shaft's lowest point can be moved when each joint motor is not under servo control.
- Mechanical stop
This is the stop that sets the absolute work envelope where the Manipulator cannot move beyond mechanically.
- Maximum zone
This is the range that contains the farthest reach of the arms where interference can occur. If the maximum radius of the hand exceeds 60 mm, add the "Range to mechanical stop" and the "Radius of the hand." The total value is specified as the maximum zone.

Table top mounting specifications

GX8-A/GX8-B/
GX8-C45***

GX8-A/GX8-B/
GX8-C55***

GX8-A/GX8-B/
GX8-C65***

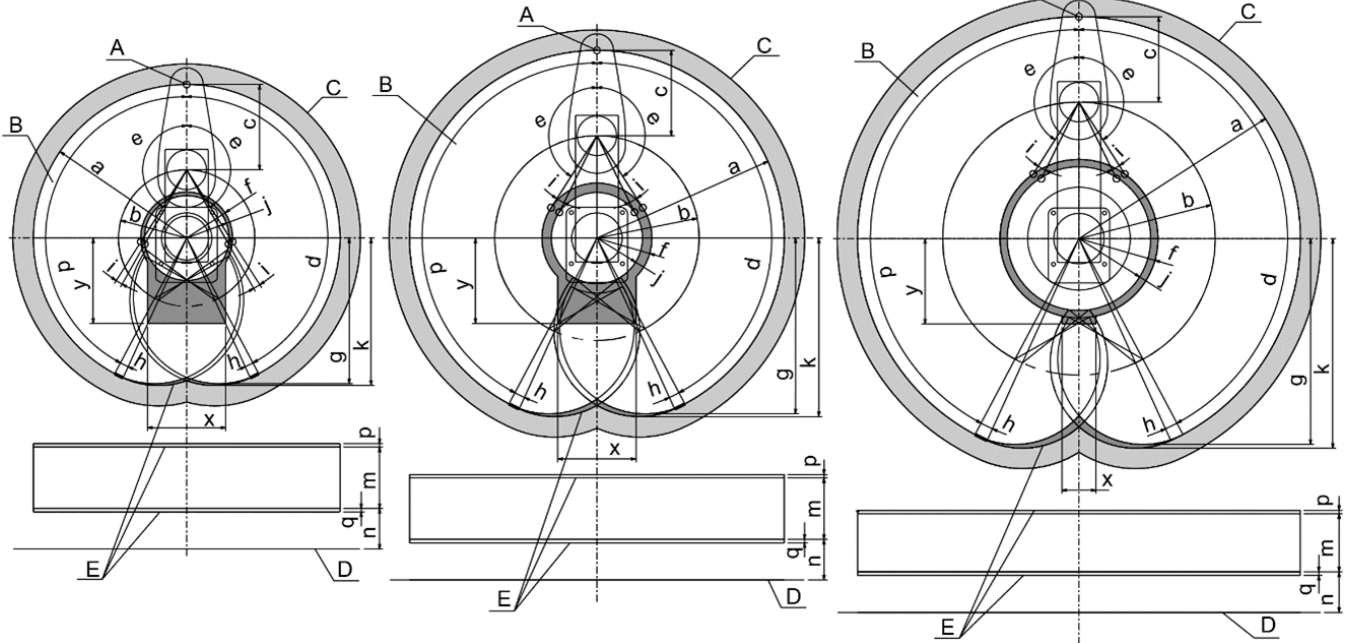

Symbol	Description
A	Center of Joint #3
B	Work envelope
C	Maximum zone
D	Base mounting surface
E	Range to mechanical stop

		GX8-A/GX8-B/GX8-C45** GX8-A/GX8-B/GX8-C45**B			
		S, E		C, P	
a	Length of Arm #1 + Arm #2 (mm)	450			
b	Length of Arm #1 (mm)	200			
c	Length of Arm #2 (mm)	250			
d	Joint #1 motion (°)	152			
e	Joint #2 motion (°)	$0 \geq Z \geq -270$	147.5	$0 \geq Z \geq -240$	147.5
		$-270 > Z \geq -330$	145	$-240 > Z \geq -300$	137.5
f	(Work envelope)	$0 \geq Z \geq -270$	134.8	$0 \geq Z \geq -240$	134.8
		$-270 > Z \geq -330$	145	$-240 > Z \geq -300$	137.5
g	(Work envelope on the back side)	426.6			
h	Angle to the Joint #1 mechanical stop (°)	1.4			

i	Angle to the Joint #2 mechanical stop (°)	$0 \geq Z \geq -270$	3.1	$0 \geq Z \geq -240$	3.1
		$-270 > Z \geq -330$	5.6	$-240 > Z \geq -300$	13.1
j	(Mechanical stop area)	$0 \geq Z \geq -270$	124	$0 \geq Z \geq -240$	124
		$-270 > Z \geq -330$	124	$-240 > Z \geq -300$	121.6
k	(Mechanical stop area of the back side)	428.8			
x	Dimensions of motion prohibited area (mm)	230		260	
y	Dimensions of motion prohibited area (mm)	-250		-280	

		GX8-A/GX8-B/GX8-C55** GX8-A/GX8-B/GX8-C55**B		GX8-A/GX8-B/GX8-C65** GX8-A/GX8-B/GX8-C65**B	
		S, E	C, P	S, E	C, P
a	Length of Arm #1 + Arm #2 (mm)	550		650	
b	Length of Arm #1 (mm)	300		400	
c	Length of Arm #2 (mm)	250			
d	Joint #1 motion (°)	152			
e	Joint #2 motion (°)	147.5	$0 \geq Z \geq -240$	147.5	147.5
			$-240 > Z \geq -300$	145	
f	(Work envelope)	161.2	$0 \geq Z \geq -240$	161.2	232
		161.2	$-240 > Z \geq -300$	172.1	
g	(Work envelope on the back side)	514.9		603.2	
h	Angle to the Joint #1 mechanical stop (°)	1.4			
i	Angle to the Joint #2 mechanical stop (°)	3.1	$0 \geq Z \geq -240$	3.1	3.1
		3.1	$-240 > Z \geq -300$	5.6	
j	(Mechanical stop area)	147.7		219.7	
k	(Mechanical stop area of the back side)	518.2		607.7	
x	Dimensions of motion prohibited area (mm)	230	260	100	160
y	Dimensions of motion prohibited area (mm)	-250	-280	-250	-280

		GX8-A/GX8-B/GX8-C*52** GX8-A/GX8-B/GX8-C*52**B		GX8-A/GX8-B/GX8-C*53** GX8-A/GX8-B/GX8-C*53**B	
		S, E	C, P	S, E	C, P
m	Joint #3 work envelope	200	170	330	300

		GX8-A/GX8-B/GX8-C*52** GX8-A/GX8-B/GX8-C*52**B		GX8-A/GX8-B/GX8-C*53** GX8-A/GX8-B/GX8-C*53**B	
		S, E	C, P	S, E	C, P
n	Distance from base mounting surface	99	96	-31	-34
p	Joint #3 mechanical stop area (upper limit)	3	1	3	1
q	Joint #3 mechanical stop area (lower limit)	15.6	12.6	10.6	7.6

Wall mounting specifications

GX8-A/GX8-B/
GX8-C45**W

GX8-A/GX8-B/
GX8-C55**W

GX8-A/GX8-B/
GX8-C65**W

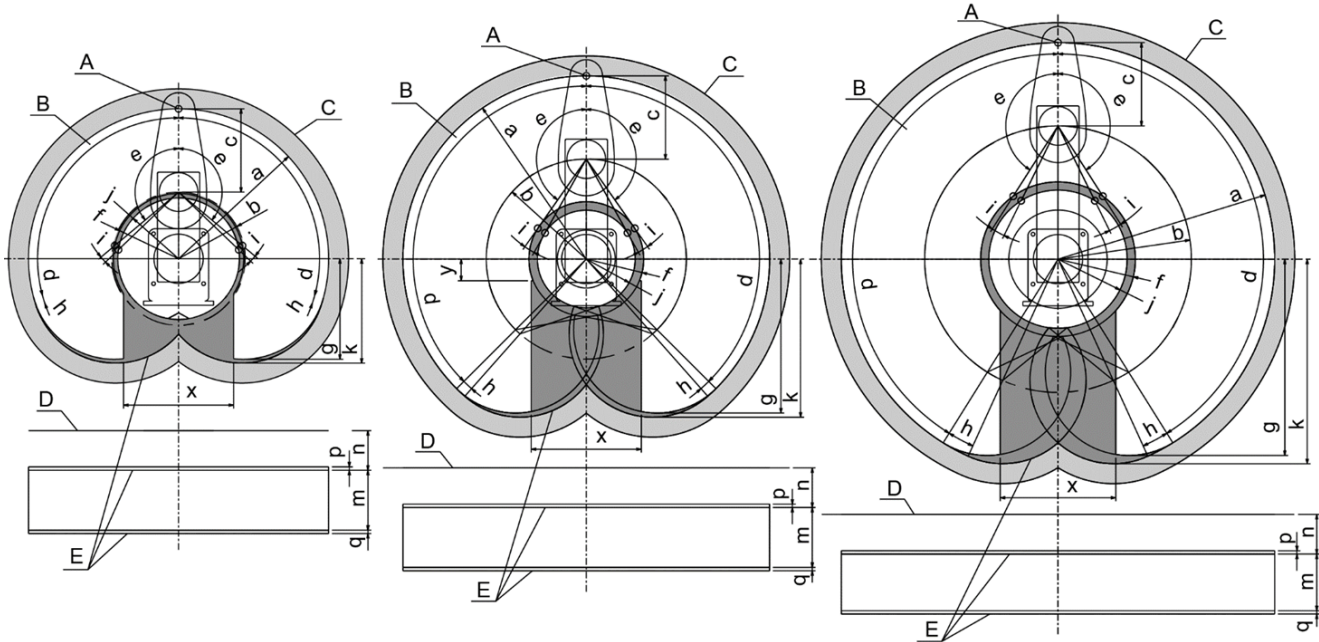

Symbol	Description
A	Center of Joint #3
B	Work envelope
C	Maximum zone
D	Base mounting surface
E	Range to mechanical stop

		GX8-A/GX8-B/GX8-C45**W		GX8-A/GX8-B/GX8-C55**W		GX8-A/GX8-B/GX8-C65**W	
		S, E	C, P	S, E	C, P	S, E	C, P
a	Length of Arm #1 + Arm #2 (mm)	450		550		650	
b	Length of Arm #1 (mm)	200		300		400	
c	Length of Arm #2 (mm)			250			
d	Joint #1 motion (°)	105		135		147.5	
e	Joint #2 motion (°)	125		147.5	145	147.5	
f	(Work envelope)	212.5		161.2	172.1	232	
g	(Work envelope on the back side)	292.5		462.1		589.2	
h	Angle to the Joint #1 mechanical stop (°)	0.9		11.2		5.4	

		GX8-A/GX8-B/GX8-C45**W		GX8-A/GX8-B/GX8-C55**W		GX8-A/GX8-B/GX8-C65**W	
		S, E	C, P	S, E	C, P	S, E	C, P
i	Angle to the Joint #2 mechanical stop (°)	6.1		3.1	5.6	3.1	
j	(Mechanical stop area)	191.7		147.7		219.7	
k	(Mechanical stop area of the back side)	295.7		499.3		607.7	
x	Dimensions of motion prohibited area (mm)	380		330			
y	Dimensions of motion prohibited area (mm)	0 (infinite on back side)		-65 (infinite on back side)		0 (infinite on back side)	

		GX8-A/GX8-B/GX8-C**2*W		GX8-A/GX8-B/GX8-C**3*W	
		S, E	C, P	S, E	C, P
m	Joint #3 work envelope	200	170	330	300
n	Distance from base mounting surface	160	193	160	193
p	Joint #3 mechanical stop area (upper limit)	3	1	3	1
q	Joint #3 mechanical stop area (lower limit)	15.6	12.6	10.6	7.6

Ceiling mounting specifications

GX8-A/GX8-B/
GX8-C45**R

GX8-A/GX8-B/
GX8-C55**R

GX8-A/GX8-B/
GX8-C65**R

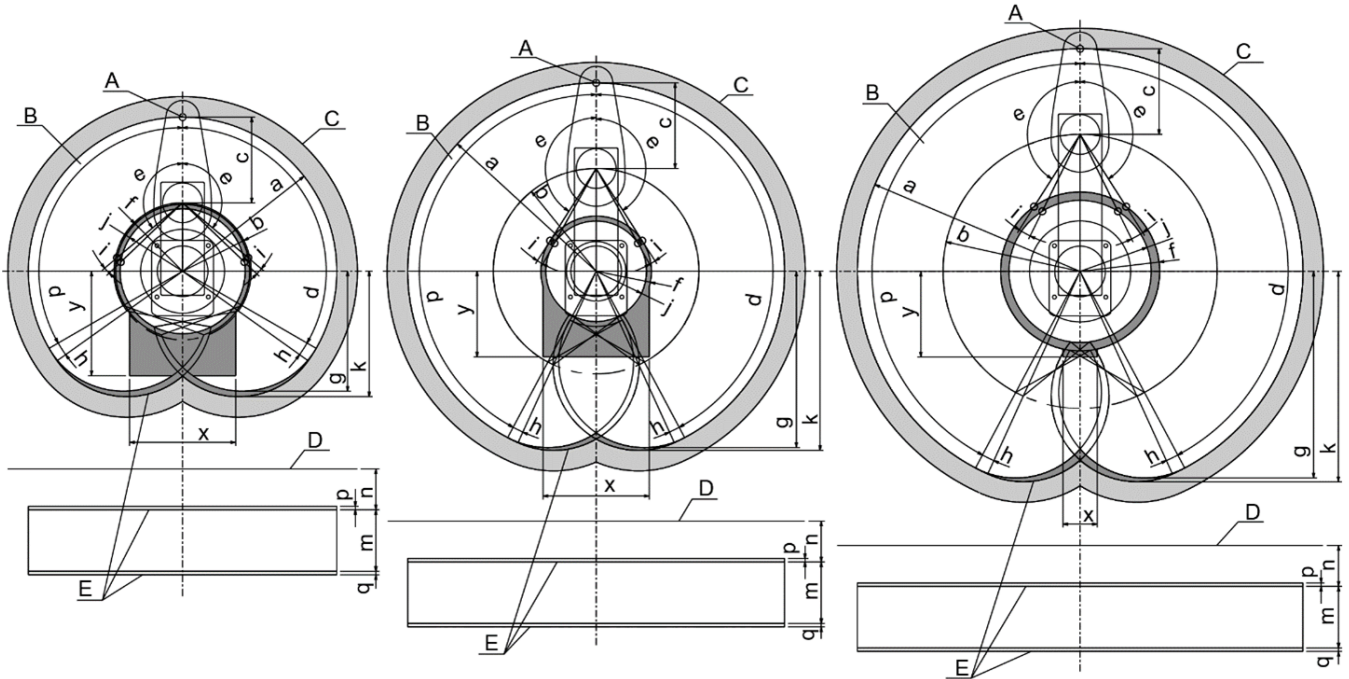

Symbol	Description
A	Center of Joint #3
B	Work envelope
C	Maximum zone
D	Base mounting surface
E	Range to mechanical stop

		GX8-A/GX8-B/GX8-C45**R		GX8-A/GX8-B/GX8-C55**R		GX8-A/GX8-B/GX8-C65**R	
		S, E	C, P	S, E	C, P	S, E	C, P
a	Length of Arm #1 + Arm #2 (mm)	450		550		650	
b	Length of Arm #1 (mm)	200		300		400	
c	Length of Arm #2 (mm)	250					
d	Joint #1 motion (°)	105		152			
e	Joint #2 motion (°)	125		147.5	145	147.5	
f	(Work envelope)	212.5		161.2	172.1	232	
g	(Work envelope on the back side)	292.5		515.4		603.2	
h	Angle to the Joint #1 mechanical stop (°)	0.9		1.4			

		GX8-A/GX8-B/GX8-C45**R		GX8-A/GX8-B/GX8-C55**R		GX8-A/GX8-B/GX8-C65**R	
		S, E	C, P	S, E	C, P	S, E	C, P
i	Angle to the Joint #2 mechanical stop (°)	6.1		3.1	5.6	3.1	
j	(Mechanical stop area)	191.7		147.7		219.7	
k	(Mechanical stop area of the back side)	295.7		518.2		607.7	
x	Dimensions of motion prohibited area (mm)	310				100	160
y	Dimensions of motion prohibited area (mm)	-305		-250	-280	-250	280

		GX8-A/GX8-B/GX8-C**2*R		GX8-A/GX8-B/GX8-C**3*R	
		S, E	C, P	S, E	C, P
m	Joint #3 work envelope	200	170	330	300
n	Distance from base mounting surface	394	427	394	427
p	Joint #3 mechanical stop area (upper limit)	3	1	3	1
q	Joint #3 mechanical stop area (lower limit)	15.6	12.6	10.6	7.6

4. GX10 GX20 Manipulators

This chapter contains information on the setup and operation of the Manipulators.
Please read this chapter thoroughly before setting up and operating the Manipulators.

4.1 Safety

The Manipulator and its related equipment should be unpacked and transported by people who have received installation training provided by Epson and the suppliers. Also, the laws and regulations of the installation country must be followed.

Before use, please read this manual and other related manuals to ensure correct use.

After reading this manual, store it in an easily accessible location for future reference.

This product is intended for transporting and assembling parts in a safely isolated area.

4.1.1 Conventions Used in This Manual

The following symbols are used in this manual to indicate important safety information. Be sure to read the descriptions shown with each symbol.

WARNING

This symbol indicates an imminently hazardous situation which, if operation is not performed properly, will result in death or serious injury.

WARNING

This symbol indicates a potentially hazardous situation which, if operation is not performed properly, could result in an injury due to electric shock.

CAUTION

This symbol indicates a potentially hazardous situation which, if operation is not performed properly, may result in a minor or moderate injury or in property damage only.

4.1.2 Design and Installation Safety

The robot system should be designed and installed by people who have received installation training provided by Epson and the suppliers.

Design personnel should refer to the following manuals:

"Safety Manual"

"Controller Manual"

"Manipulator Manual"

Refer to the following section for the installation safety information.

Environment and Installation

Be sure to read this section and follow the safety information before installation to ensure that the installation work is performed safely.

4.1.2.1 Strength of the Ball Screw Spline

If a load exceeding the allowable bending load is applied to the ball screw spline, it may not work properly due to deformation or breakage of the shaft.

If a load exceeding the allowable value is applied to the ball screw spline, the ball screw spline unit must be replaced.

The allowable load varies depending on the distance over which the load is applied. To calculate the allowable load, refer to the formula below.

Allowable bending moment

GX10-B/GX10-C/GX20-B/GX20-C: $M=50,000 \text{ N}\cdot\text{mm}$

Calculation example: 500 N load applied at 100 mm from the end of the spline nut

Moment

$$M = F \cdot L = 100 \cdot 500 = 50,000 \text{ N}\cdot\text{mm}$$

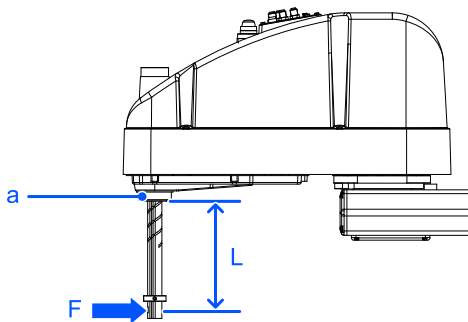

Symbol	Description
a	Spline nut end

4.1.3 Operation Safety

The following items are safety precautions for operating personnel:

WARNING

- Be sure to read the Safety Manual before use. Operating the robot system without understanding the safety information can be extremely dangerous and may result in serious injury or severe equipment damage.
- Before operating the robot system, make sure that no one is inside the safety barriers. The robot system can be operated in the teaching operation mode even when someone is inside the safety barriers. Even though the motion of the Manipulator is always restricted (low speed and low power) to ensure operator safety, an unexpected movement by the Manipulator can be extremely dangerous and may cause serious safety problems.
- If the Manipulator makes any abnormal movements during operation of the robot system, do not hesitate to immediately press the emergency stop switch.

WARNING

- To perform the power supply lockout, remove the power plug. Be sure to connect the AC power cable to a power outlet. Do not connect it directly to a factory power source.
- Before performing any replacement work, inform others in the area that you are working, and then turn off the Controller and related equipment, and unplug the power cable from the power source. Performing any work procedure with the power turned on is extremely dangerous and may result in electric shock and/or malfunction of the robot system.
- Do not connect or disconnect the connector of the M/C cable while the Controller is turned on. There is a risk the Manipulator may malfunction, which is extremely hazardous. Also, performing any work procedure with the power turned on may result in electric shock and/or malfunction of the robot system.

CAUTION

- Whenever possible, only one person should operate the robot system. If it is necessary to operate with more than one person, ensure that all personnel communicate with each other and take all necessary safety precautions.
- Joints #1, #2, and #4:
If the Manipulator is operated repeatedly with an operating angle of 5° or less, the bearings used in the joints are likely to cause oil film shortage. Repeated operation may cause premature damage. To prevent premature damage, operate the Manipulator to move each joint to an angle of 50° or more about once per hour.
Joint #3:
If the up-and-down motion of the hand is 10 mm or less, move the hand about half or more of its maximum stroke about once per hour.
- When the robot is operating at low speed (Speed: 5 to 20%), vibration (resonance) may occur continuously during operation depending on the combination of the arm orientation and hand load. Vibration occurs due to the natural vibration frequency of the arm and can be reduced by taking the following measures:
 - Changing the robot speed
 - Changing the teach points
 - Changing the hand load

4.1.4 Emergency Stop

Each robot system needs equipment that will allow the operator to immediately stop the system's operation. Install an emergency stop device by using emergency stop input from the Controller or other equipment.

Before using the emergency stop switch, be aware of the following points.

- The emergency stop switch should be used to stop the Manipulator only in case of emergencies.
- Besides pressing the emergency stop switch when an emergency occurs, to stop the Manipulator during program operation, use the Pause or STOP (program stop) statements assigned to a standard I/O.
The Pause and STOP statements do not turn off motor energization, and so the brake is not locked.

To place the robot system in emergency stop mode in a non-emergency (normal) situation, press the emergency stop switch while the Manipulator is not operating.

Do not press the emergency stop switch unnecessarily while the Manipulator is operating normally. It could shorten the lifespan of the following components.

- Brakes
The brakes will be locked, which will shorten the lifespan of the brakes due to worn brake friction plates.
 - Normal brake lifespan:
About 2 years (when the brakes are used 100 times/day)
or about 20,000 times
- Reduction gears
An emergency stop applies an impact to the reduction gear, which can shorten its life.

If the Manipulator is stopped by turning off the Controller while it is operating, the following problems may occur.

- Reduced life and damage to reduction gear
- Position shift at the joints

If a power outage or other unavoidable Controller power-off occurs during Manipulator operation, check the following points after power is restored.

- Damage in reduction gear
- Shifting of the joints from their proper positions

If there was any shifting, maintenance is required. For more information, please contact the supplier.

Stopping distance of emergency stop

The Manipulator during operation cannot stop immediately after the emergency stop switch is pressed. Also, the stopping time and movement distance vary depending on the following factors.

- Hand weight, WEIGHT setting, ACCEL setting, workpiece weight, SPEED setting, movement posture, etc.

For the stopping time and movement distance of the Manipulator, refer to the following section.

[Appendix B: Stopping Time and Stopping Distance at Emergency Stop](#)

4.1.5 Safeguard (SG)

To maintain a safe working zone, safety barriers must be set up around the Manipulator, and safeguards must be installed at the entrance and exit of the safety barriers.

The term "safeguard" as used in this manual refers to a safety device with an interlock that allows entry into the safety barriers. Specifically, this includes safety door switches, safety barriers, light curtains, safety gates, safety floor mats, and so on. The safeguard is an input that informs the Robot Controller that an operator may be inside the safeguard area. You must assign at least one Safeguard (SG) in Safety Function Manager.

When the safeguard is opened, Protective Stop operates to change to the safeguard open state (display: SO).

- **Safeguard open**
Operations are prohibited. Further robot operation is not possible until either the safeguard is closed, the latched state is released, and a command is executed, or the TEACH or TEST operation mode is turned on and the enable circuit is activated.
- **Safeguard closed**
The robot can operate automatically in an unrestricted (high power) state.

WARNING

- If a third party accidentally releases the safeguard while an operator is working inside the safety barriers, this may result in a hazardous situation. To protect the operator working inside the safety barriers, implement measures to lock out or tag out the latch release switch.
- To protect operators working near the robot, be sure to connect a safeguard switch and make sure that it works properly.

Installing safety barriers

When installing safety barriers within the maximum range of the Manipulator, combine safety functions such as SLP. Carefully take into account the size of the hand and the workpieces to be held so that no interference occurs between the operating parts and the safety barriers.

Installing safeguards

Design the safeguards so that they satisfy the following requirements:

- When using a key switch type safety device, use a switch that forcibly opens the interlock contacts. Do not use switches that open their contacts using the spring force of the interlock.
- When using an interlock mechanism, do not disable the interlock mechanism.

Considering the stopping distance

During operation, the Manipulator cannot stop immediately even if the safeguard is opened. Also, the stopping time and movement distance vary depending on the following factors.

Hand weight, WEIGHT setting, ACCEL setting, workpiece weight, SPEED setting, movement posture, etc.

For the stopping time and movement distance of the Manipulator, refer to the following section.

[Appendix C: Stopping Time and Stopping Distance When Safeguard is Open](#)

Precautions for safeguard operation

Do not open the safeguard unnecessarily while the motor is energized. Frequent safeguard inputs will reduce the life of the relay.

- Normal relay lifespan: About 20,000 times

4.1.6 Arm Movement Method in the Emergency Stop State

In the emergency stop state, move the Manipulator joints directly by hand as shown below.

- **Joint #1:**
Push Arm #1 by hand.
- **Joint #2:**
Push Arm #2 by hand.
- **Joint #3:**
The joint cannot be moved up or down by hand because the electromagnetic brake is activated.
Move the joint while pressing down the brake release switch.

▪ **Joint #4:**

The joint cannot be rotated by hand because the electromagnetic brake is activated.
 Move the joint while pressing down the brake release switch.

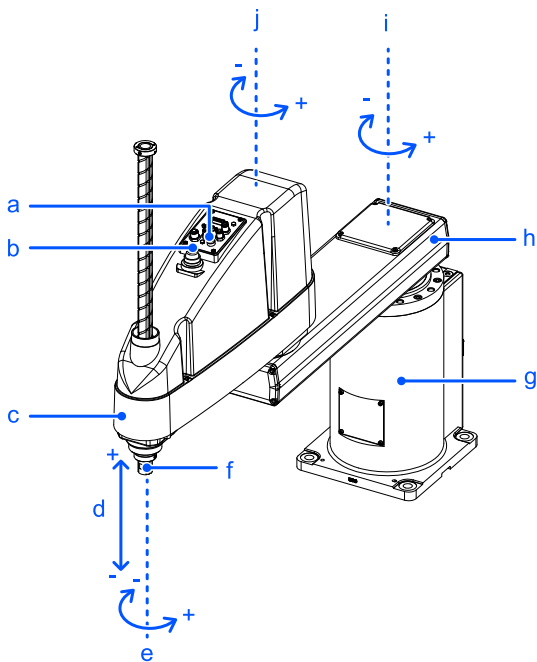

Symbol	Description
a	Joint #3 and Joint #4 brake release switch
b	Indicating lamp
c	Arm #2
d	Joint #3 (up/down movement)
e	Joint #4 (rotation)
f	Shaft
g	Base
h	Arm #1
i	Joint #1 (rotation)
j	Joint #2 (rotation)

 **KEY POINTS**

The brake release switch is used with both Joint #3 and Joint #4. Press the brake release switch while in the emergency stop state to simultaneously release the brakes on Joint #3 and Joint #4.

When pressing the brake release switch, watch for the shaft descending or rotating under the weight of the hand.

4.1.7 ACCELS Setting for CP Motion

To make the Manipulator move in CP motion, set ACCELS properly in the SPEL program according to the tip load and the Z-axis height.

 **KEY POINTS**

If the ACCELS settings are not properly configured, the following problem may occur.

- Shortened lifespan and damage to the ball screw spline

Set ACCELS as shown below based on the Z-axis height.

ACCELS setting values by the Z-axis height and tip load

GX10-B/GX10-C

Z-axis Height (mm)	Tip Load	
	5 kg or Less	10 kg or Less
$0 > Z \geq -100$	25000 or less	18000 or less
$-100 > Z \geq -200$		11000 or less
$-200 > Z \geq -300$	15000 or less	7500 or less
$-300 > Z \geq -420$	11000 or less	5500 or less

GX20-B/GX20-C

Z-axis Height (mm)	Tip Load			
	5 kg or less	10 kg or less	15 kg or less	20 kg or less
$0 > Z \geq -100$	25000 or less	18000 or less	12000 or less	9000 or less
$-100 > Z \geq -200$		11000 or less	7000 or less	5500 or less
$-200 > Z \geq -300$	15000 or less	7500 or less	5000 or less	3500 or less
$-300 > Z \geq -420$	11000 or less	5500 or less	3500 or less	2500 or less

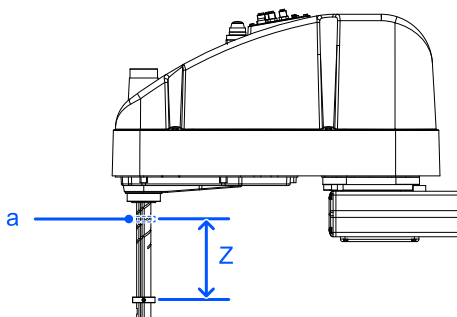

Symbol	Description
a	Z-axis height 0 (origin position)

Also, if a CP motion was performed with incorrect values set, check the following point.

- No deformation or bending of the shaft of the ball screw spline

4.1.8 Warning Labels

The Manipulator has the following warning labels.

Specific hazards exist in the vicinity of areas with the warning labels. Be thoroughly careful in handling.

To ensure that the Manipulator is operated and maintained safely, be sure to follow the safety information and warnings indicated on the warning labels. Also, do not tear, damage, or remove these warning labels.

4.1.8.1 Warning Labels

A



Touching any internal electrified parts while the power is turned on may cause electric shock.

B



The surface of the Manipulator is hot during and after operation, and there is a risk of burns.

4.1.8.2 Information Labels

1

This indicates the product name, model name, serial number, information of supported laws and regulations, product specifications (Weight, MAX.REACH, MAX.PAYLOAD, AIR PRESSURE, Motor Power), Main document No., manufacturer, importer, date of manufacture, country of manufacture, and the like.

For details, see the label affixed to the product.

2



Indicates the position of a brake release button.

3



Indicates the position of a threaded hole for an eyebolt mounting screw.

4.1.8.3 Labelled Locations

Common (Arm #2)

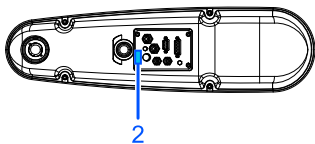
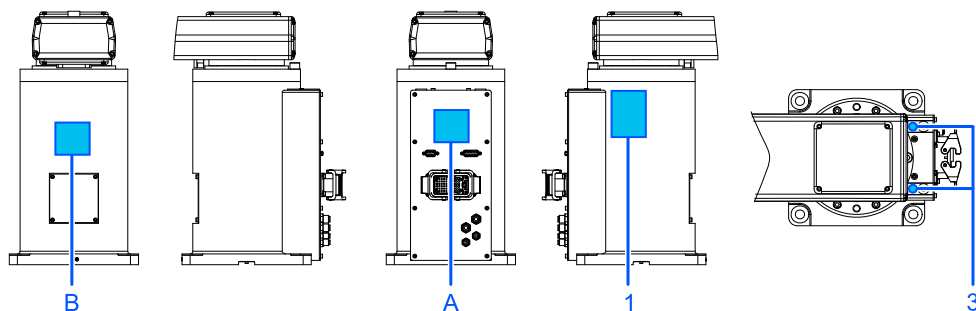
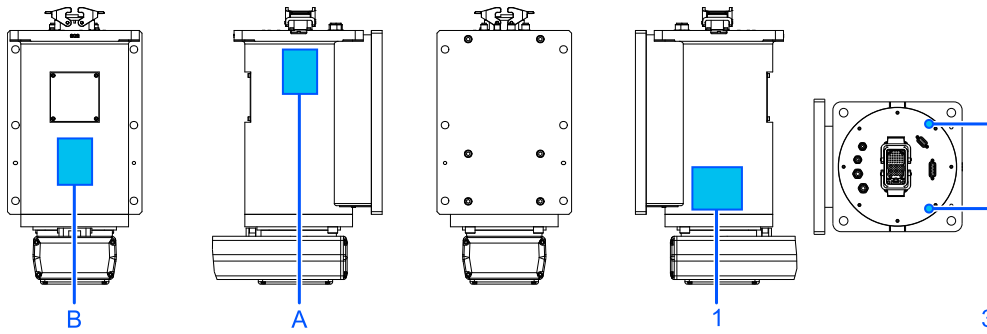
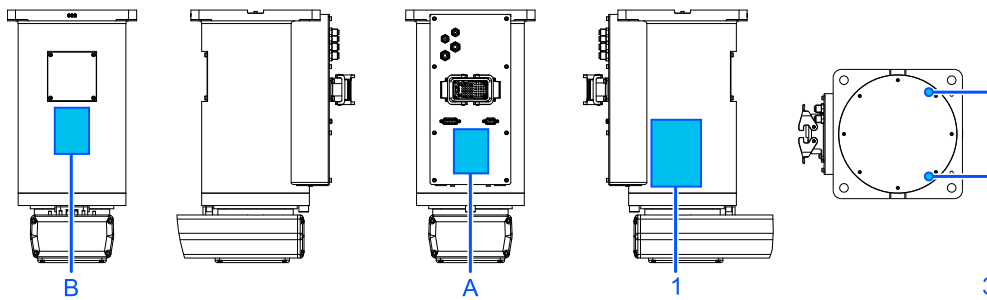

Table top mounting specifications (GX10-B/GX10-C/GX20-B/GX20-C****)



Wall mounting specifications (GX10-B/GX10-C/GX20-B/GX20-C**W)****Ceiling mounting specifications (GX10-B/GX10-C/GX20-B/GX20-C****R)****4.1.9 Responses for Emergencies or Malfunctions****4.1.9.1 When a Collision with the Manipulator Occurs**

If the Manipulator has collided with a mechanical stop, peripheral device, or other object, discontinue use and contact the supplier.

4.1.9.2 Entanglement with the Manipulator

If an operator gets caught between the Manipulator and a mechanical part such as a base table, press the emergency stop switch to release the operator by using the following method.

- Operator body is entangled with a robot arm
The brake is not functioning. Move the arm manually.
- Operator body is entangled with the shaft
The brake is functioning. Press the brake release switch, and move the shaft.

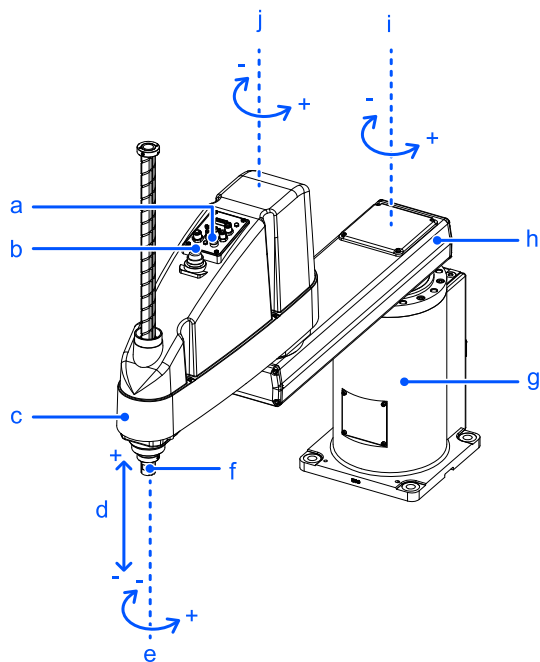

Symbol	Description
a	Joint #3 and Joint #4 brake release switch
b	Indicating lamp
c	Arm #2
d	Joint #3 (up/down movement)
e	Joint #4 (rotation)
f	Shaft
g	Base
h	Arm #1
i	Joint #1 (rotation)
j	Joint #2 (rotation)

CAUTION

- While the brake release switch is being pressed, in addition to Joint #3, Joint #4 may also move due to its own weight. Be careful of the shaft descending and rotating.

4.2 Specifications

4.2.1 Model Name GX10-B/GX20-B

GX10-B65 1 S □
 [a] [b] [c] [d] [e]

- **a: Model name**
 GX10-B: GX10-B series
 GX20-B: GX20-B series
- **b: Arm length**
 65: 650 mm (GX10-B series only)
 85: 850 mm
 A0: 1000 mm (GX20-B series only)
- **c: Joint #3 stroke**
 1: 180 mm (GX10-B/GX20-B**1S*), 150 mm (GX10-B/GX20-B**1C*, P*)
 4: 420 mm (GX10-B/GX20-B**4S*), 390 mm (GX10-B/GX20-B**4C*, P*)
- **d: Environmental specifications**
 S: Standard (equivalent to IP20)
 C: Cleanroom & ESD (anti-static)
 P: Protection class: IP 65
- **e: Mounting specifications**
 □: Table top mounting
 W: Wall mounting
 R: Ceiling mounting

Environmental specifications

- Cleanroom & ESD (anti-static) specifications: GX10-B/GX20-B***C*
 Manipulators with cleanroom & ESD (anti-static) specifications have a base design with the standard specifications, but as an additional feature, have reduced dust emissions from the Manipulator to enable use in cleanroom environments. ESD specifications are specifications that use conductive materials for or apply plating to the major resin parts as anti-static measures.
 We have confirmed that the Manipulator tip (tool mounting section) is at ± 5 V or less, even directly after the measuring operation according to Seiko Epson standards.
 If you need any other detailed information, please contact the supplier.
 Also, please check the amount of charge on any hand, wiring, or the like that you will attach to the robot on your own before use.
- Protected-model (IP65): GX10-B/GX20-B***P*
 Manipulators with protected-models have a base design with the standard specifications, but as an additional feature, can be used in adverse environments such as those exposed to oil smoke and dust.
 These are compliant with the IP65 protection class (IEC 60529, JIS C0920).

For details on the specifications, refer to the following section.

[Appendix A: Specifications Table](#)

Model list

GX10-B series

Arm Length	Joint #3 Stroke	Environmental Specifications	Mounting Specifications	Model Number
650	180	Standard	Table top	GX10-B651S
			Wall	GX10-B651SW
			Ceiling	GX10-B651SR
	150	Cleanroom & ESD	Table top	GX10-B651C
			Wall	GX10-B651CW
			Ceiling	GX10-B651CR
		Protection	Table top	GX10-B651P
			Wall	GX10-B651PW
			Ceiling	GX10-B651PR
	420	Standard	Table top	GX10-B654S
			Wall	GX10-B654SW
			Ceiling	GX10-B654SR
	390	Cleanroom & ESD	Table top	GX10-B654C
			Wall	GX10-B654CW
			Ceiling	GX10-B654CR
		Protection	Table top	GX10-B654P
			Wall	GX10-B654PW
			Ceiling	GX10-B654PR
850	180	Standard	Table top	GX10-B851S
			Wall	GX10-B851SW
			Ceiling	GX10-B851SR
	150	Cleanroom & ESD	Table top	GX10-B851C
			Wall	GX10-B851CW
			Ceiling	GX10-B851CR
		Protection	Table top	GX10-B851P
			Wall	GX10-B851PW
			Ceiling	GX10-B851PR
	420	Standard	Table top	GX10-B854S
			Wall	GX10-B854SW
			Ceiling	GX10-B854SR

Arm Length	Joint #3 Stroke	Environmental Specifications	Mounting Specifications	Model Number
	390	Cleanroom & ESD	Table top	GX10-B854C
			Wall	GX10-B854CW
			Ceiling	GX10-B854CR
		Protection	Table top	GX10-B854P
			Wall	GX10-B854PW
			Ceiling	GX10-B854PR

(Units: mm)

GX20-B series

Arm Length	Joint #3 Stroke	Environmental Specifications	Mounting Specifications	Model Number	
850	180	Standard	Table top	GX20-B851S	
			Wall	GX20-B851SW	
			Ceiling	GX20-B851SR	
	150	Cleanroom & ESD	Table top	GX20-B851C	
			Wall	GX20-B851CW	
			Ceiling	GX20-B851CR	
		Protection	Table top	GX20-B851P	
			Wall	GX20-B851PW	
			Ceiling	GX20-B851PR	
	420	Standard	Table top	GX20-B854S	
			Wall	GX20-B854SW	
			Ceiling	GX20-B854SR	
		Cleanroom & ESD	Table top	GX20-B854C	
			Wall	GX20-B854CW	
			Ceiling	GX20-B854CR	
	390	Protection	Table top	GX20-B854P	
			Wall	GX20-B854PW	
			Ceiling	GX20-B854PR	
1000		180	Standard	Table top	GX20-BA01S
				Wall	GX20-BA01SW
				Ceiling	GX20-BA01SR
	150	Cleanroom & ESD	Table top	GX20-BA01C	
			Wall	GX20-BA01CW	
			Ceiling	GX20-BA01CR	
		Protection	Table top	GX20-BA01P	
			Wall	GX20-BA01PW	
			Ceiling	GX20-BA01PR	
420	Standard	Table top	GX20-BA04S		
		Wall	GX20-BA04SW		
		Ceiling	GX20-BA04SR		

Arm Length	Joint #3 Stroke	Environmental Specifications	Mounting Specifications	Model Number
	390	Cleanroom & ESD	Table top	GX20-BA04C
			Wall	GX20-BA04CW
			Ceiling	GX20-BA04CR
		Protection	Table top	GX20-BA04P
			Wall	GX20-BA04PW
			Ceiling	GX20-BA04PR

(Units: mm)

4.2.2 Model Name GX10-C/GX20-C

GX10-C65 1 S □
 [a] [b] [c] [d] [e]

- **a: Model name**
 GX10-C: GX10-C series
 GX20-C: GX20-C series
- **b: Arm length**
 65: 650 mm (GX10-C series only)
 85: 850 mm
 A0: 1000 mm (GX20-C series only)
- **c: Joint #3 stroke**
 1: 180 mm (GX10-C/GX20-C**1S*), 150 mm (GX10-C/GX20-C**1C*, P*)
 4: 420 mm (GX10-C/GX20-C**4S*), 390 mm (GX10-C/GX20-C**4C*, P*)
- **d: Environmental specifications**
 S: Standard (equivalent to IP20)
 C: Cleanroom & ESD (anti-static)
 P: Protection class: IP 65
- **e: Mounting specifications**
 □: Table top mounting
 W: Wall mounting
 R: Ceiling mounting

Environmental specifications

- Cleanroom & ESD (anti-static) specifications: GX10-C/GX20-C***C*
 Manipulators with cleanroom & ESD (anti-static) specifications have a base design with the standard specifications, but as an additional feature, have reduced dust emissions from the Manipulator to enable use in cleanroom environments.
 ESD specifications are specifications that use conductive materials for or apply plating to the major resin parts as anti-static measures.
 We have confirmed that the Manipulator tip (tool mounting section) is at ± 5 V or less, even directly after the measuring operation according to Seiko Epson standards.
 If you need any other detailed information, please contact the supplier.
 Also, please check the amount of charge on any hand, wiring, or the like that you will attach to the robot on your own before use.
- Protected-model (IP65): GX10-C/GX20-C***P*
 Manipulators with protected-models have a base design with the standard specifications, but as an additional feature, can be used in adverse environments such as those exposed to oil smoke and dust.
 These are compliant with the IP65 protection class (IEC 60529, JIS C0920).

For details on the specifications, refer to the following section.

[Appendix A: Specifications Table](#)

Model list

GX10-C series

Arm Length	Joint #3 Stroke	Environmental Specifications	Mounting Specifications	Model Number
650	180	Standard	Table top	GX10-C651S
			Wall	GX10-C651SW
			Ceiling	GX10-C651SR
	150	Cleanroom & ESD	Table top	GX10-C651C
			Wall	GX10-C651CW
			Ceiling	GX10-C651CR
		Protection	Table top	GX10-C651P
			Wall	GX10-C651PW
			Ceiling	GX10-C651PR
	420	Standard	Table top	GX10-C654S
			Wall	GX10-C654SW
			Ceiling	GX10-C654SR
	390	Cleanroom & ESD	Table top	GX10-C654C
			Wall	GX10-C654CW
			Ceiling	GX10-C654CR
Protection		Table top	GX10-C654P	
		Wall	GX10-C654PW	
		Ceiling	GX10-C654PR	
850	180	Standard	Table top	GX10-C851S
			Wall	GX10-C851SW
			Ceiling	GX10-C851SR
	150	Cleanroom & ESD	Table top	GX10-C851C
			Wall	GX10-C851CW
			Ceiling	GX10-C851CR
		Protection	Table top	GX10-C851P
			Wall	GX10-C851PW
			Ceiling	GX10-C851PR
	420	Standard	Table top	GX10-C854S
			Wall	GX10-C854SW
			Ceiling	GX10-C854SR

Arm Length	Joint #3 Stroke	Environmental Specifications	Mounting Specifications	Model Number
	390	Cleanroom & ESD	Table top	GX10-C854C
			Wall	GX10-C854CW
			Ceiling	GX10-C854CR
		Protection	Table top	GX10-C854P
			Wall	GX10-C854PW
			Ceiling	GX10-C854PR

(Units: mm)

GX20-C series

Arm Length	Joint #3 Stroke	Environmental Specifications	Mounting Specifications	Model Number	
850	180	Standard	Table top	GX20-C851S	
			Wall	GX20-C851SW	
			Ceiling	GX20-C851SR	
	150	Cleanroom & ESD	Table top	GX20-C851C	
			Wall	GX20-C851CW	
			Ceiling	GX20-C851CR	
		Protection	Table top	GX20-C851P	
			Wall	GX20-C851PW	
			Ceiling	GX20-C851PR	
	420	Standard	Table top	GX20-C854S	
			Wall	GX20-C854SW	
			Ceiling	GX20-C854SR	
		Cleanroom & ESD	Table top	GX20-C854C	
			Wall	GX20-C854CW	
			Ceiling	GX20-C854CR	
390	Protection	Table top	GX20-C854P		
		Wall	GX20-C854PW		
		Ceiling	GX20-C854PR		
	1000	180	Standard	Table top	GX20-CA01S
				Wall	GX20-CA01SW
				Ceiling	GX20-CA01SR
150		Cleanroom & ESD	Table top	GX20-CA01C	
			Wall	GX20-CA01CW	
			Ceiling	GX20-CA01CR	
		Protection	Table top	GX20-CA01P	
			Wall	GX20-CA01PW	
			Ceiling	GX20-CA01PR	
420	Standard	Table top	GX20-CA04S		
		Wall	GX20-CA04SW		
		Ceiling	GX20-CA04SR		

Arm Length	Joint #3 Stroke	Environmental Specifications	Mounting Specifications	Model Number
	390	Cleanroom & ESD	Table top	GX20-CA04C
			Wall	GX20-CA04CW
			Ceiling	GX20-CA04CR
		Protection	Table top	GX20-CA04P
			Wall	GX20-CA04PW
			Ceiling	GX20-CA04PR

(Units: mm)

4.2.3 Names of Parts and Their Dimensions

4.2.3.1 Table Top Mounting Specifications

Standard specifications GX10-B/GX10-C/GX20-B/GX20-C***S

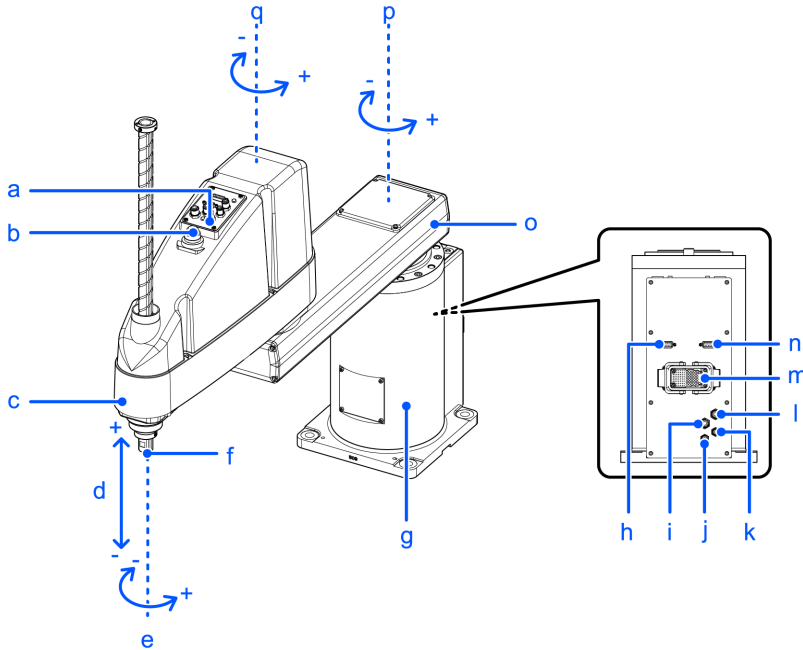

Symbol	Description
a	Joint #3 and Joint #4 brake release switch
b	Indicating lamp
c	Arm #2
d	Joint #3 (up/down movement)
e	Joint #4 (rotation)
f	Shaft
g	Base
h	User connector (9-pin D-sub connector)
i	Fitting for ø6 mm tube (blue)
j	Fitting for ø4 mm tube (blue)
k	Fitting for ø4 mm tube (white)
l	Fitting for ø6 mm tube (white)
m	M/C cable housing
n	User connector (15-pin D-sub connector)
o	Arm #1
p	Joint #1 (rotation)
q	Joint #2 (rotation)

KEY POINTS

- The brake release switch is used with both Joint #3 and Joint #4. Press the brake release switch while in the emergency stop state to simultaneously release the brakes on Joint #3 and Joint #4.
- Before starting any maintenance work, be sure to turn off the Controller and inform others in the surrounding area that work is in progress. Performing any work procedure with the power turned on is extremely dangerous and may result in electric shock and/or malfunction of the robot system.

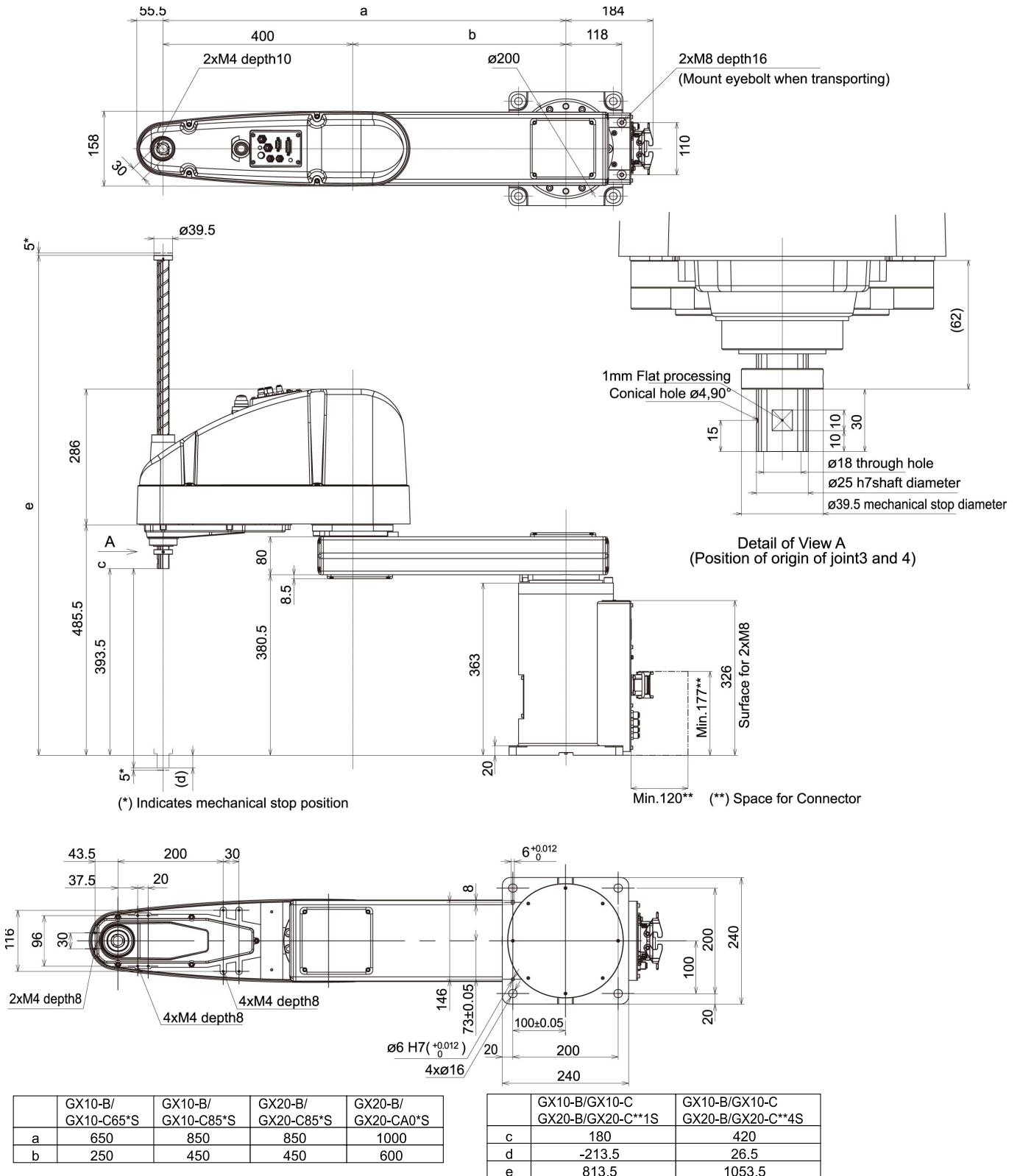

Cleanroom & ESD specifications GX10-B/GX10-C/GX20-B/GX20-C*C**

The parts shown below differ from the standard specifications.

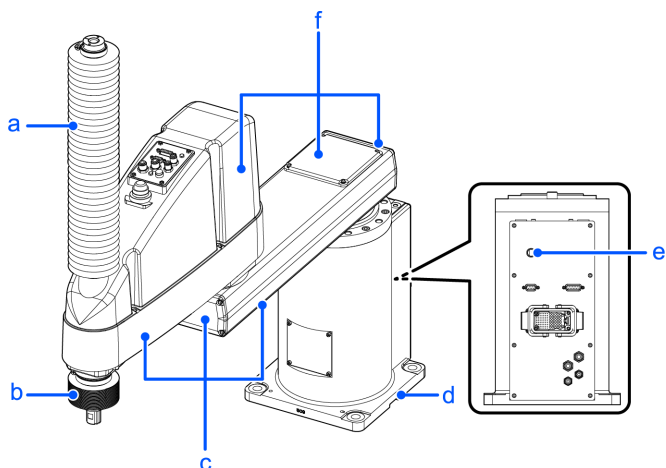

Symbol	Description
a	Upper bellows
b	Lower bellows
c	Plating covers (anti-static specifications)
d	Table top mounting surface cover
e	Exhaust port
f	Plating covers (anti-static specifications)

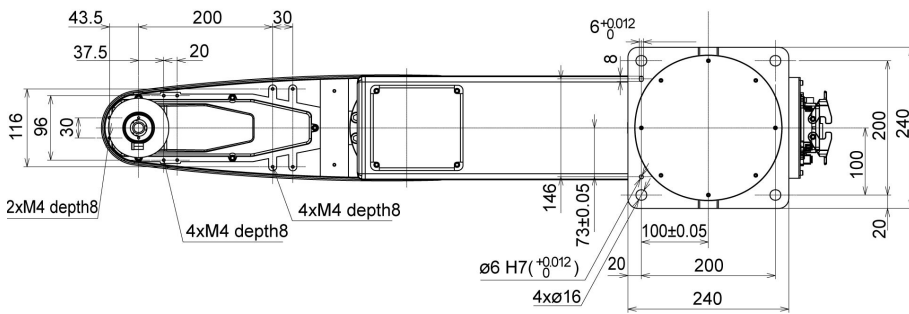
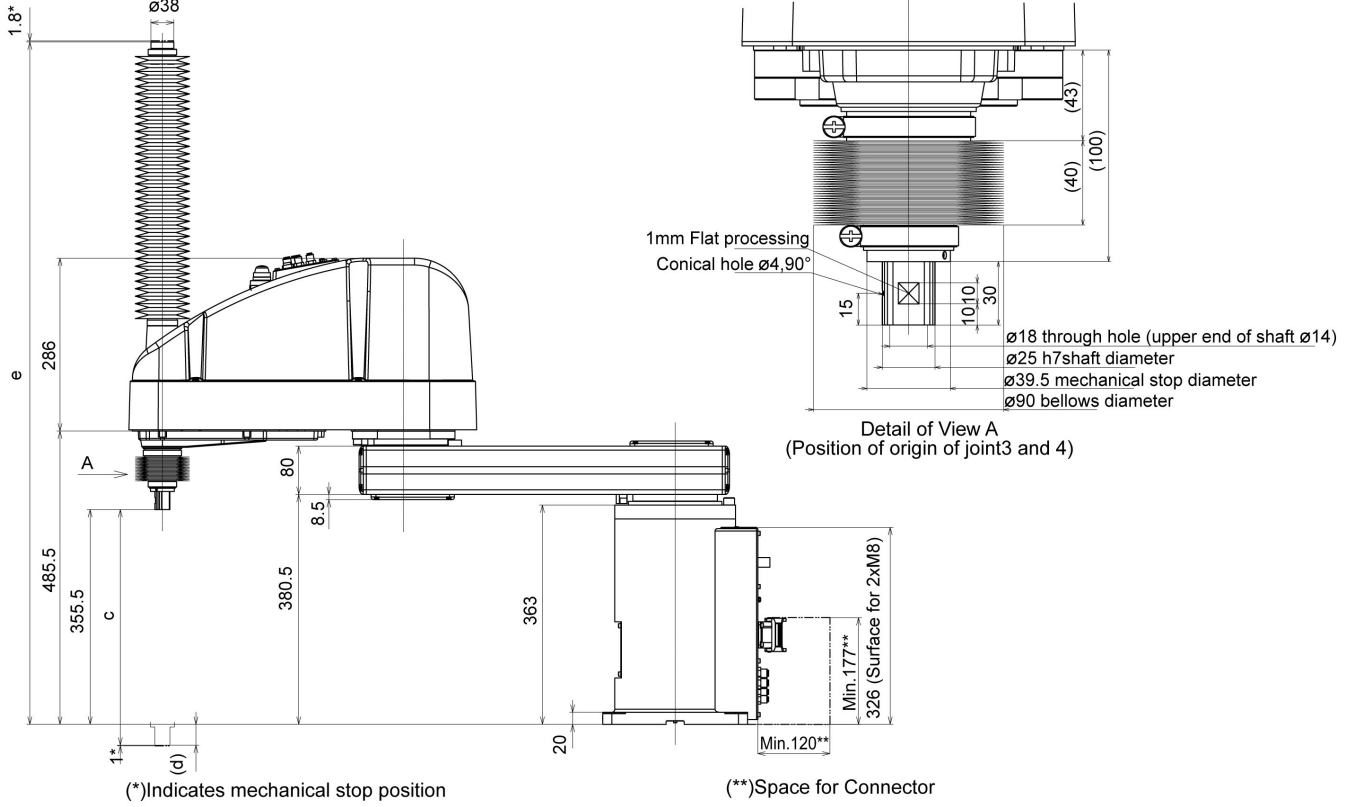
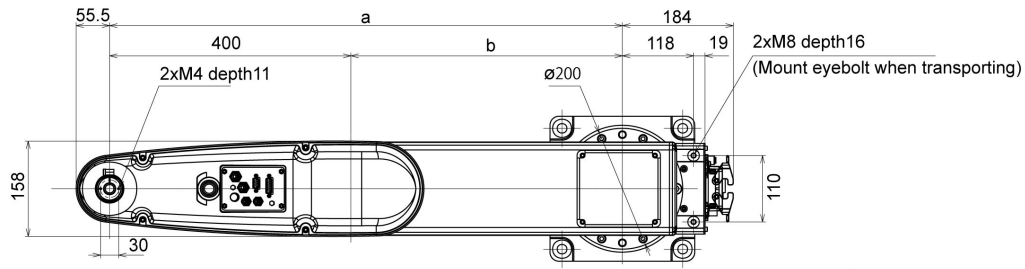

	GX10-B/ GX10-C65°C	GX10-B/ GX10-C85°C	GX20-B/ GX20-C85°C	GX20-B/ GX20-CA0°C
a	650	850	850	1000
b	250	450	450	600

	GX10-B/GX10-C GX20-B/GX20-C**1C	GX10-B/GX10-C GX20-B/GX20-C**4C
c	150	390
d	-205.5	34.5
e	870.5	1129.5

Protected-models GX10-B/GX10-C/GX20-B/GX20-C*P**

The parts shown below differ from the standard specifications.

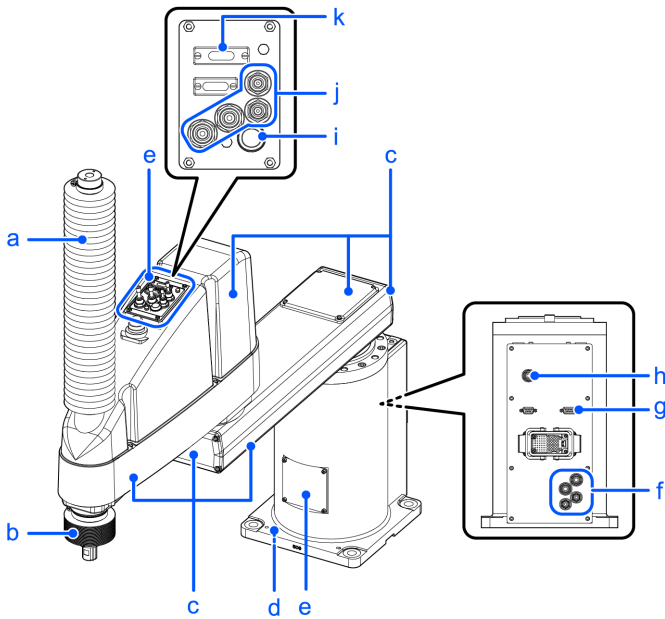

Symbol	Description
a	Upper bellows
b	Lower bellows
c	Plating cover (oil-resistant specifications)
d	Stainless steel plate for table top mounting surface
e	Stainless steel plate
f	Fittings with cover (protected-model)
g	User connector (protected-model)
h	Exhaust port
i	Joint #3 and Joint #4 brake release switch (protected-model)
j	Fittings with cover (protected-model)
k	User connector (protected-model)

KEY POINTS

- For protected-models, all screws used for the exterior are stainless steel screws. (except for screws used for stops).
- The part of the M/C cable housing is not IP65 compliant when the M/C cable hood is not connected.

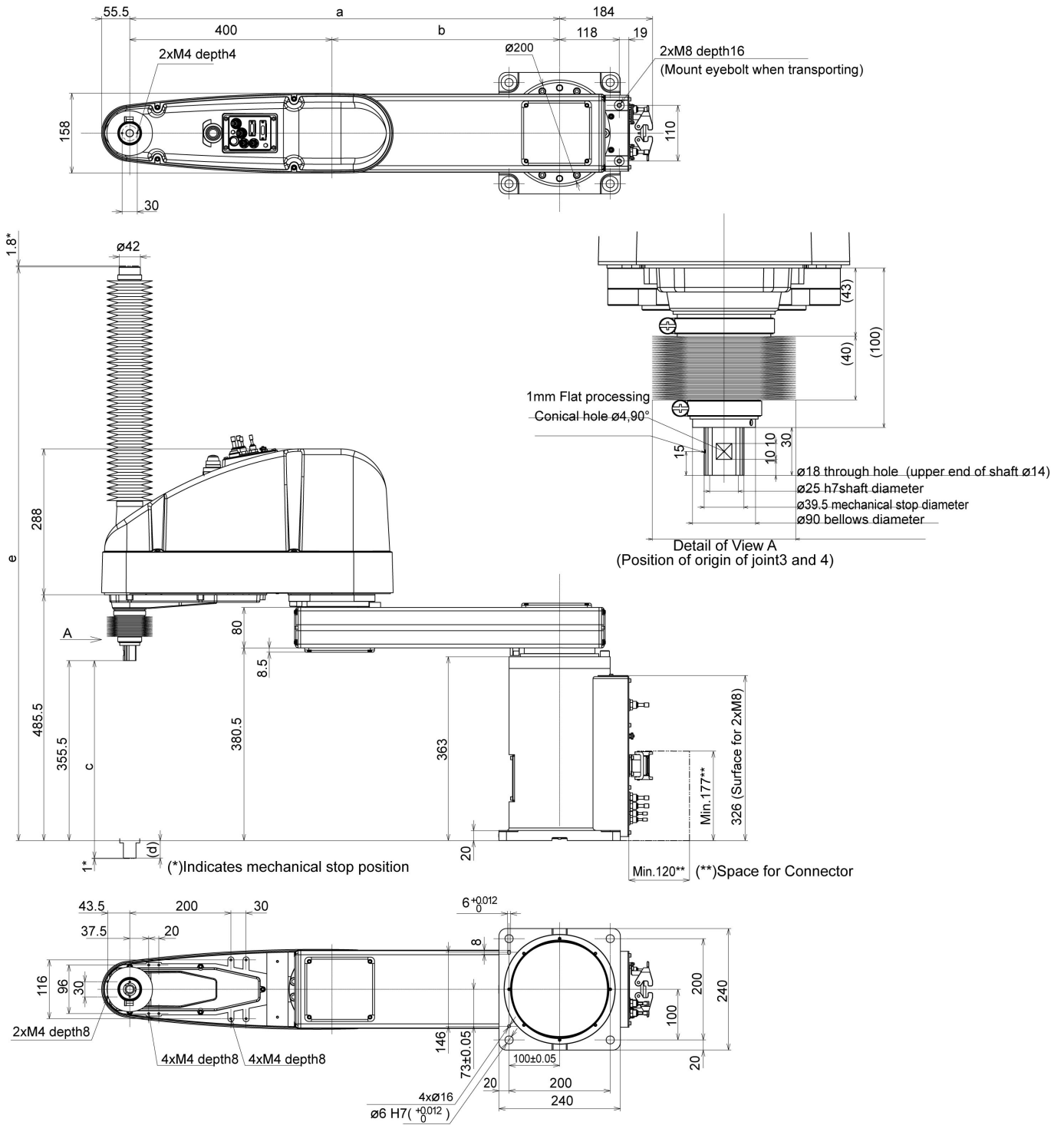

	GX10-B/ GX10-C65*P	GX10-B/ GX10-C85*P	GX20-B/ GX20-C85*P	GX20-B/ GX20-CA0*P
a	650	850	850	1000
b	250	450	450	600

	GX10-B/GX10-C GX20-B/GX20-C**1P	GX10-B/GX10-C GX20-B/GX20-C**4P
c	150	390
d	-205.5	34.5
e	874	1133

4.2.3.2 Wall Mounting Specifications

Standard specifications GX10-B/GX10-C/GX20-B/GX20-C***SW

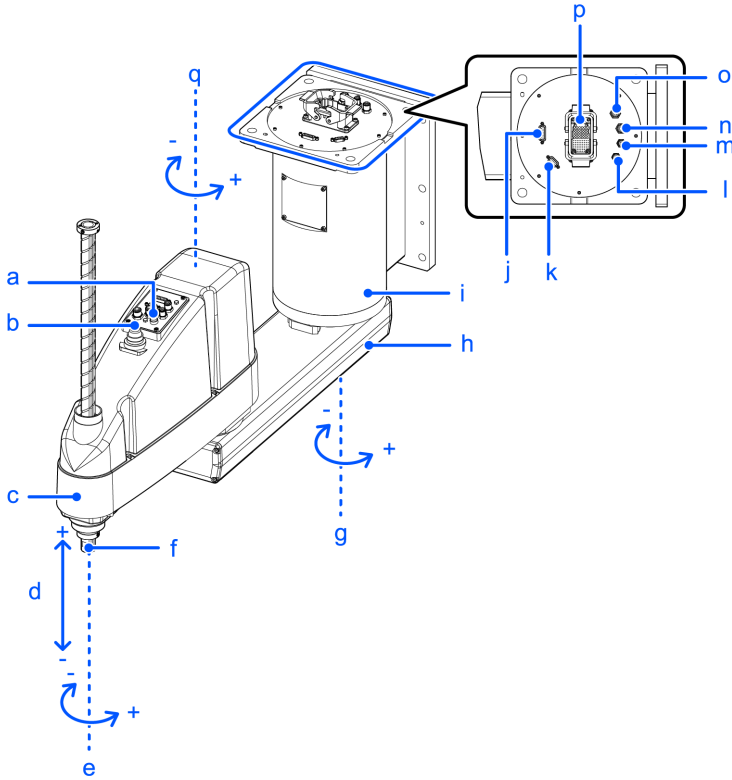

Symbol	Description
a	Joint #3 and Joint #4 brake release switch
b	Indicating lamp
c	Arm #2
d	Joint #3 (up/down movement)
e	Joint #4 (rotation)
f	Shaft
g	Joint #1 (rotation)
h	Arm #1
i	Base
j	User connector (15-pin D-sub connector)
k	User connector (9-pin D-sub connector)
l	Fitting for ø4 mm tube (blue)
m	Fitting for ø4 mm tube (white)
n	Fitting for ø6 mm tube (blue)
o	Fitting for ø6 mm tube (white)
p	M/C cable housing

Symbol	Description
q	Joint #2 (rotation)

KEY POINTS

- The brake release switch is used with both Joint #3 and Joint #4. Press the brake release switch while in the emergency stop state to simultaneously release the brakes on Joint #3 and Joint #4.
- Before starting any maintenance work, be sure to turn off the Controller and inform others in the surrounding area that work is in progress. Performing any work procedure with the power turned on is extremely dangerous and may result in electric shock and/or malfunction of the robot system.

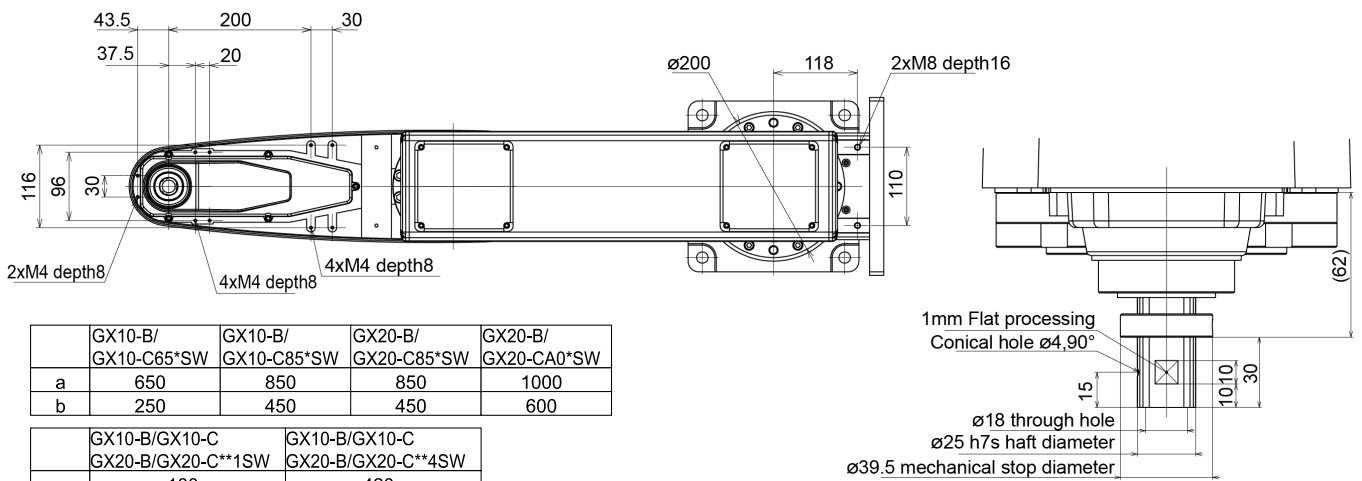
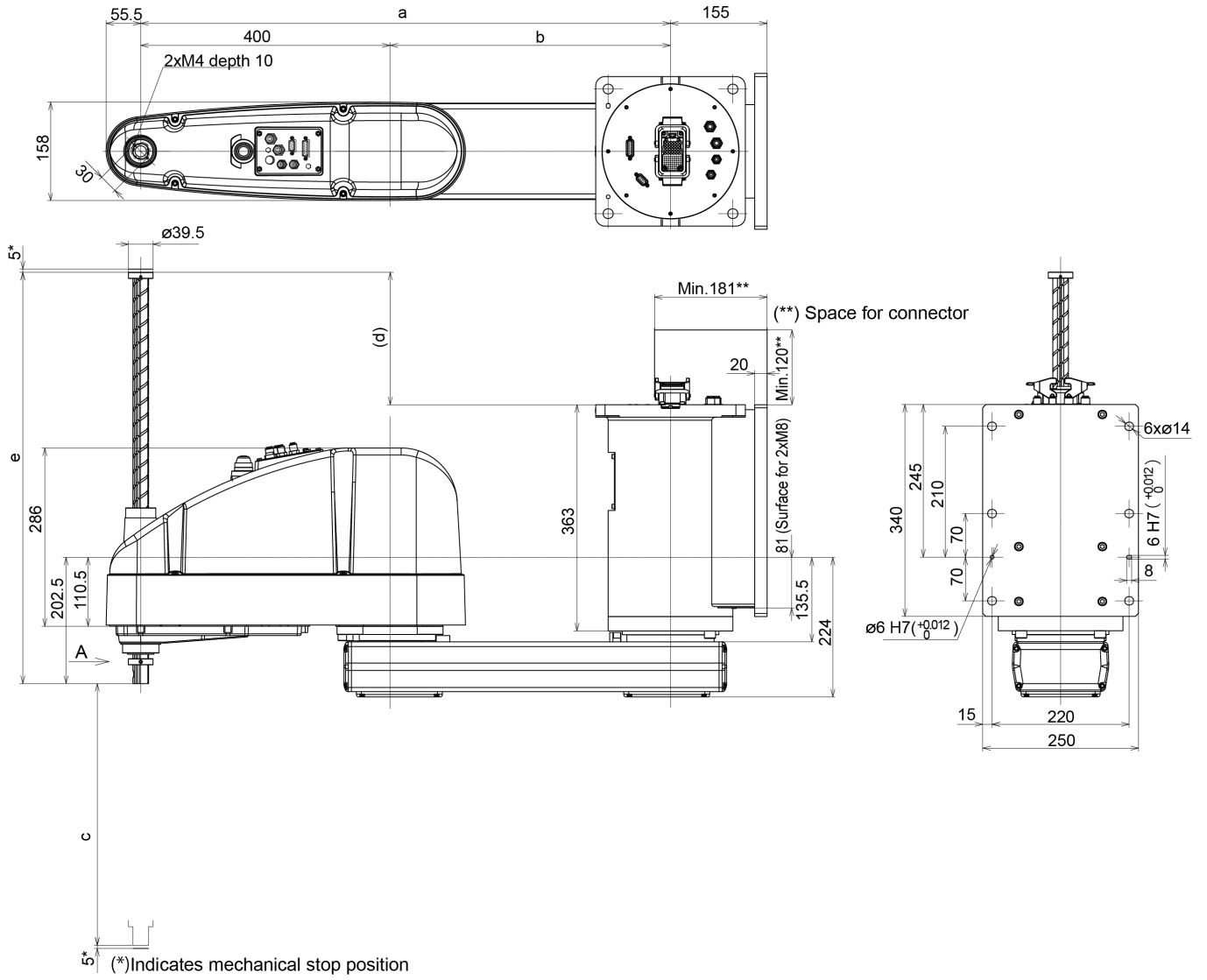

	GX10-B/ GX10-C65*SW	GX10-B/ GX10-C85*SW	GX20-B/ GX20-C85*SW	GX20-B/ GX20-CA0*SW
a	650	850	850	1000
b	250	450	450	600

	GX10-B/GX10-C GX20-B/GX20-C**1SW	GX10-B/GX10-C GX20-B/GX20-C**4SW
c	180	420
d	-27.5	212.5
e	420	660

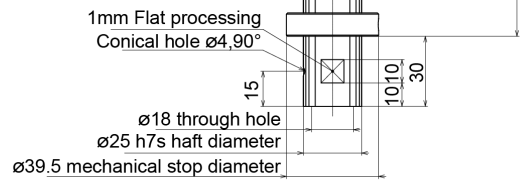

Detail of View A
(Position of origin of joint3 and 4)

Cleanroom & ESD specifications GX10-B/GX10-C/GX20-B/GX20-C*CW**

The parts shown below differ from the standard specifications.

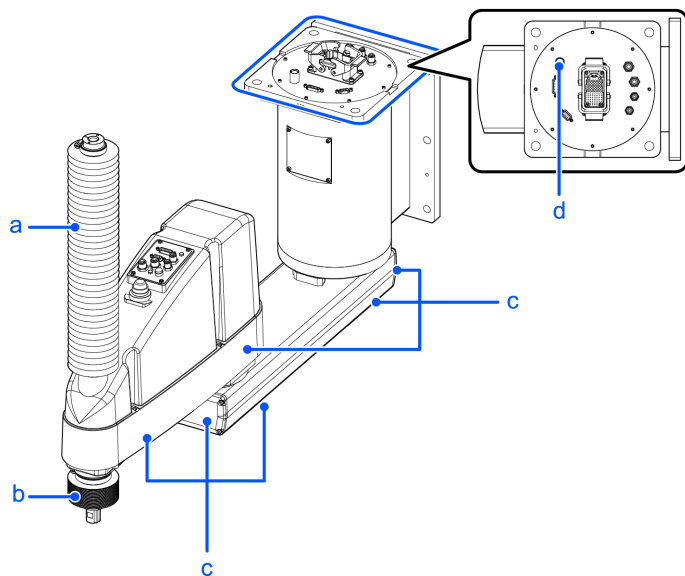

Symbol	Description
a	Upper bellows
b	Lower bellows
c	Plating covers (anti-static specifications)
d	Exhaust port

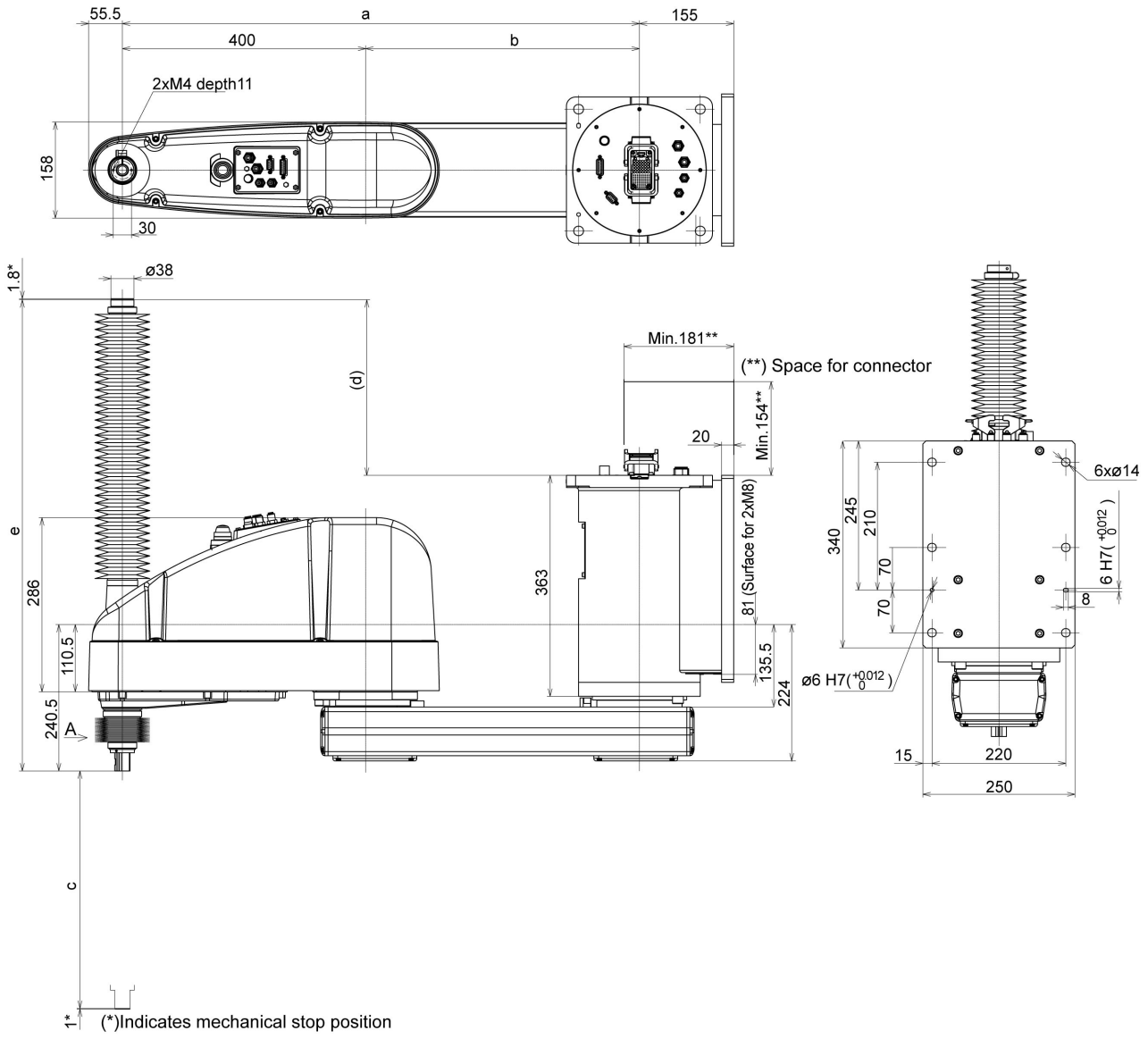

	GX10-B/ GX10-C65*CW	GX10-B/ GX10-C85*CW	GX20-B/ GX20-C85*CW	GX20-B/ GX20-CA0*CW
a	650	850	850	1000
b	250	450	450	600

	GX10-B/GX10-C GX20-B/GX20-C**1CW	GX10-B/GX10-C GX20-B/GX20-C**4CW
c	150	390
d	29.5	288.5
e	515	774

Detail of View A
(Position of origin of joint3 and 4)

Protected-models GX10-B/GX10-C/GX20-B/GX20-C*PW**

The parts shown below differ from the standard specifications.

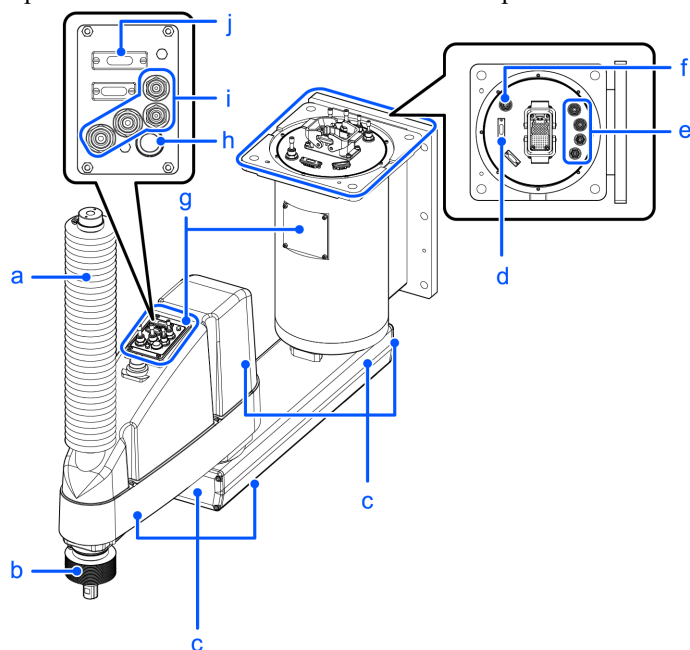

Symbol	Description
a	Upper bellows
b	Lower bellows
c	Plating cover (oil-resistant specifications)
d	User connector (protected-model)
e	Fittings with cover (protected-model)
f	Exhaust port
g	Stainless steel plate
h	Joint #3 and Joint #4 brake release switch (protected-model)
i	Fittings with cover (protected-model)
j	User connector (protected-model)

KEY POINTS

- For protected-models, all screws used for the exterior are stainless steel screws. (except for screws used for stops).
- The part of the M/C cable housing is not IP65 compliant when the M/C cable hood is not connected.

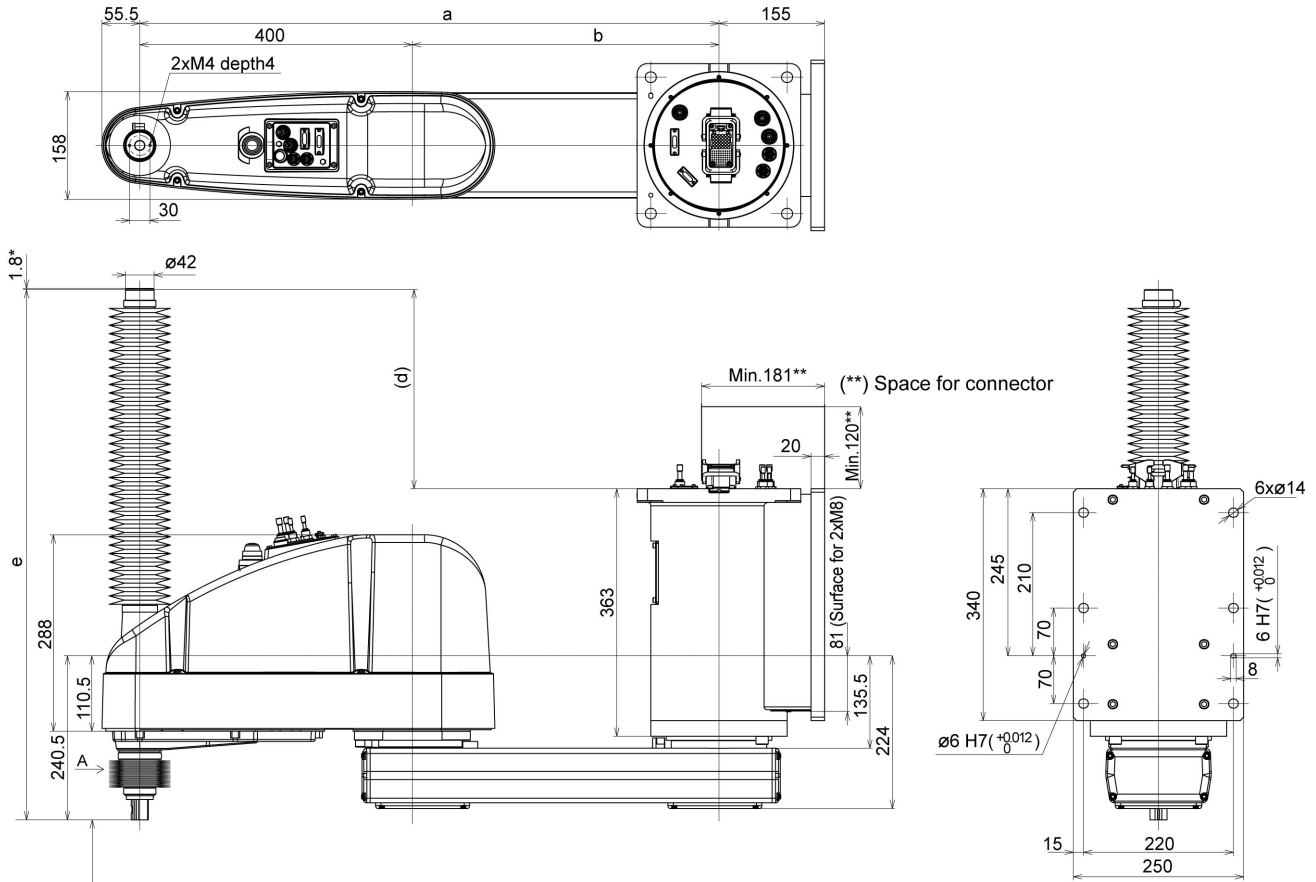

1* (*)Indicates mechanical stop position

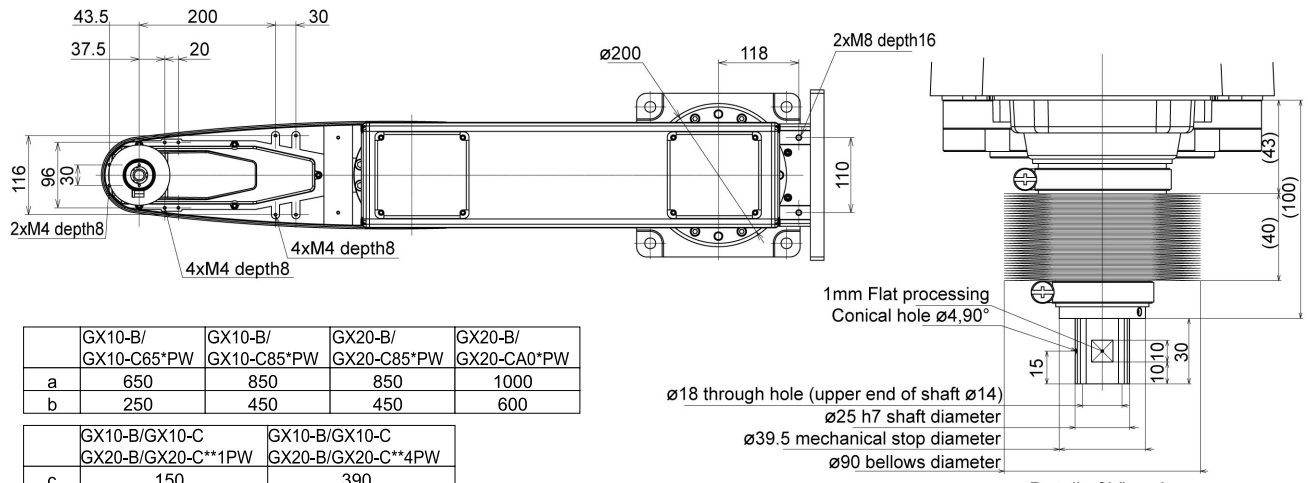

	GX10-B/ GX10-C65*PW	GX10-B/ GX10-C85*PW	GX20-B/ GX20-C85*PW	GX20-B/ GX20-CA0*PW
a	650	850	850	1000
b	250	450	450	600

	GX10-B/GX10-C GX20-B/GX20-C**1PW	GX10-B/GX10-C GX20-B/GX20-C**4PW
c	150	390
d	33	292
e	518.5	777.5

Detail of View A
(Position of origin of joint3 and 4)

4.2.3.3 Ceiling Mounting Specifications

Standard specifications GX10-B/GX10-C/GX20-B/GX20-C***SR

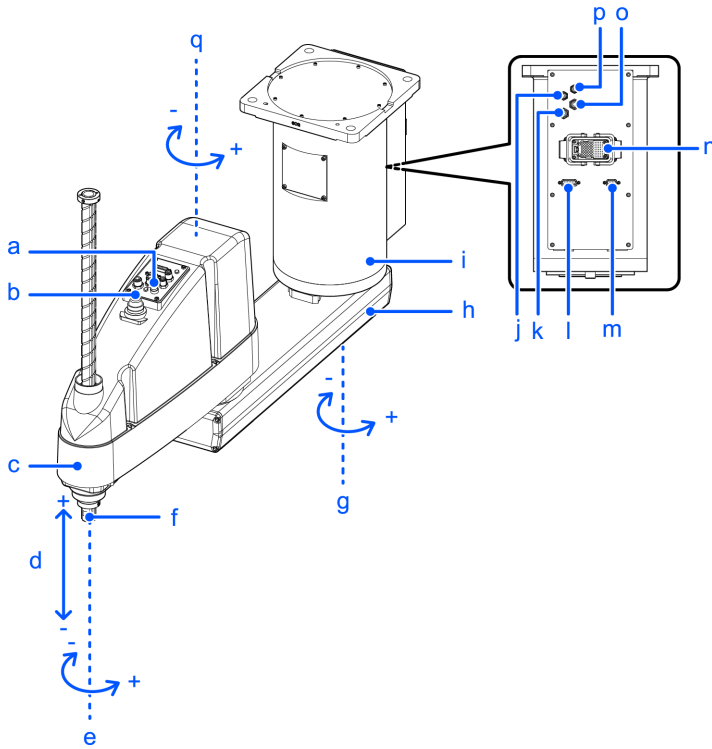

Symbol	Description
a	Joint #3 and Joint #4 brake release switch
b	Indicating lamp
c	Arm #2
d	Joint #3 (up/down movement)
e	Joint #4 (rotation)
f	Shaft
g	Joint #1 (rotation)
h	Arm #1
i	Base
j	Fitting for ø4 mm tube (white)
k	Fitting for ø6 mm tube (white)
l	User connector (15-pin D-sub connector)
m	User connector (9-pin D-sub connector)
n	M/C cable housing
o	Fitting for ø6 mm tube (blue)
p	Fitting for ø4 mm tube (blue)

Symbol	Description
q	Joint #2 (rotation)

KEY POINTS

- The brake release switch is used with both Joint #3 and Joint #4. Press the brake release switch while in the emergency stop state to simultaneously release the brakes on Joint #3 and Joint #4.
- Before starting any maintenance work, be sure to turn off the Controller and inform others in the surrounding area that work is in progress. Performing any work procedure with the power turned on is extremely dangerous and may result in electric shock and/or malfunction of the robot system.

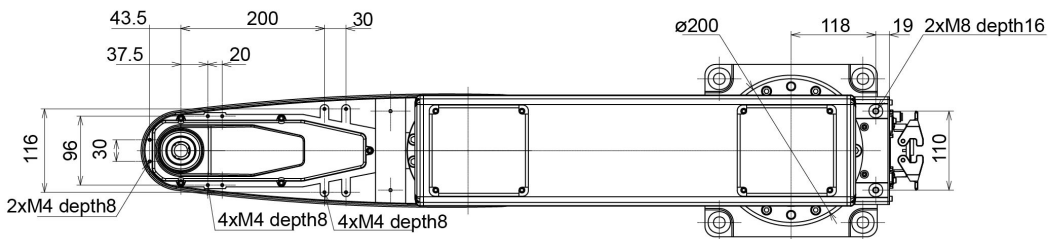
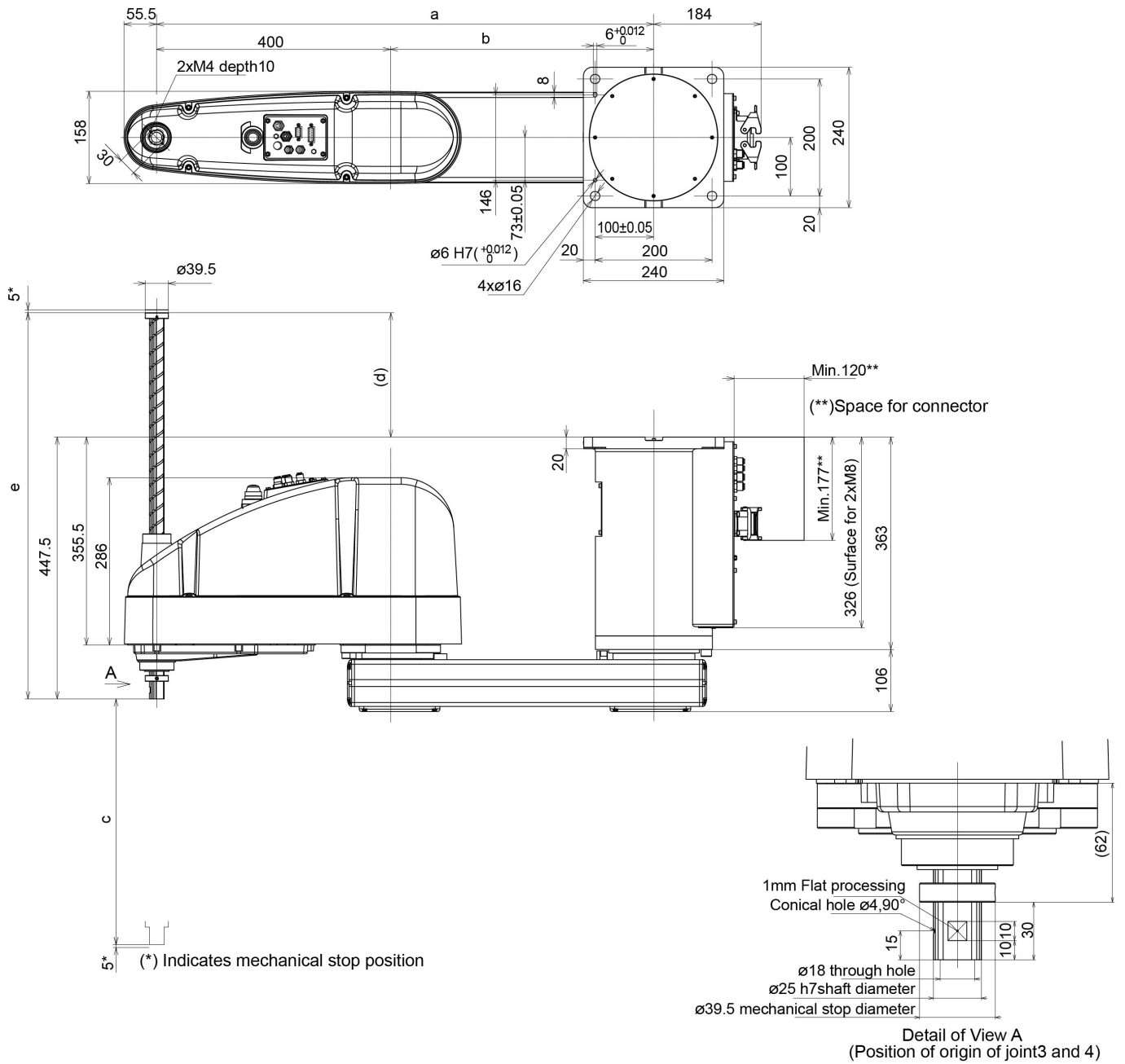

	GX10-B/ GX10-C65*SR	GX10-B/ GX10-C85*SR	GX20-B/ GX20-C85*SR	GX20-B/ GX20-CA0*SR
a	650	850	850	1000
b	250	450	450	600

	GX10-B/GX10-C GX20-B/GX20-C**1SR	GX10-B/GX10-C GX20-B/GX20-C**4SR
c	180	420
d	-27.5	212.5
e	420	660

Cleanroom & ESD specifications GX10-B/GX10-C/GX20-B/GX20-C*CR**

The parts shown below differ from the standard specifications.

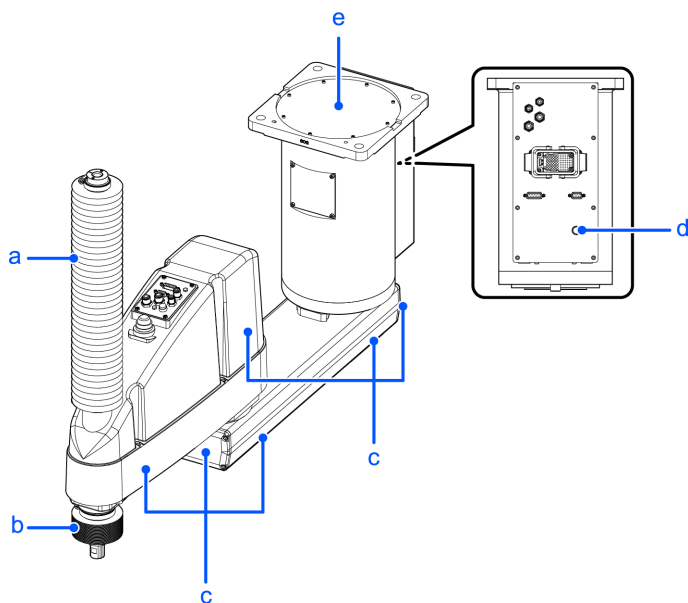

Symbol	Description
a	Upper bellows
b	Lower bellows
c	Plating covers (anti-static specifications)
d	Exhaust port
e	Ceiling mounting surface cover

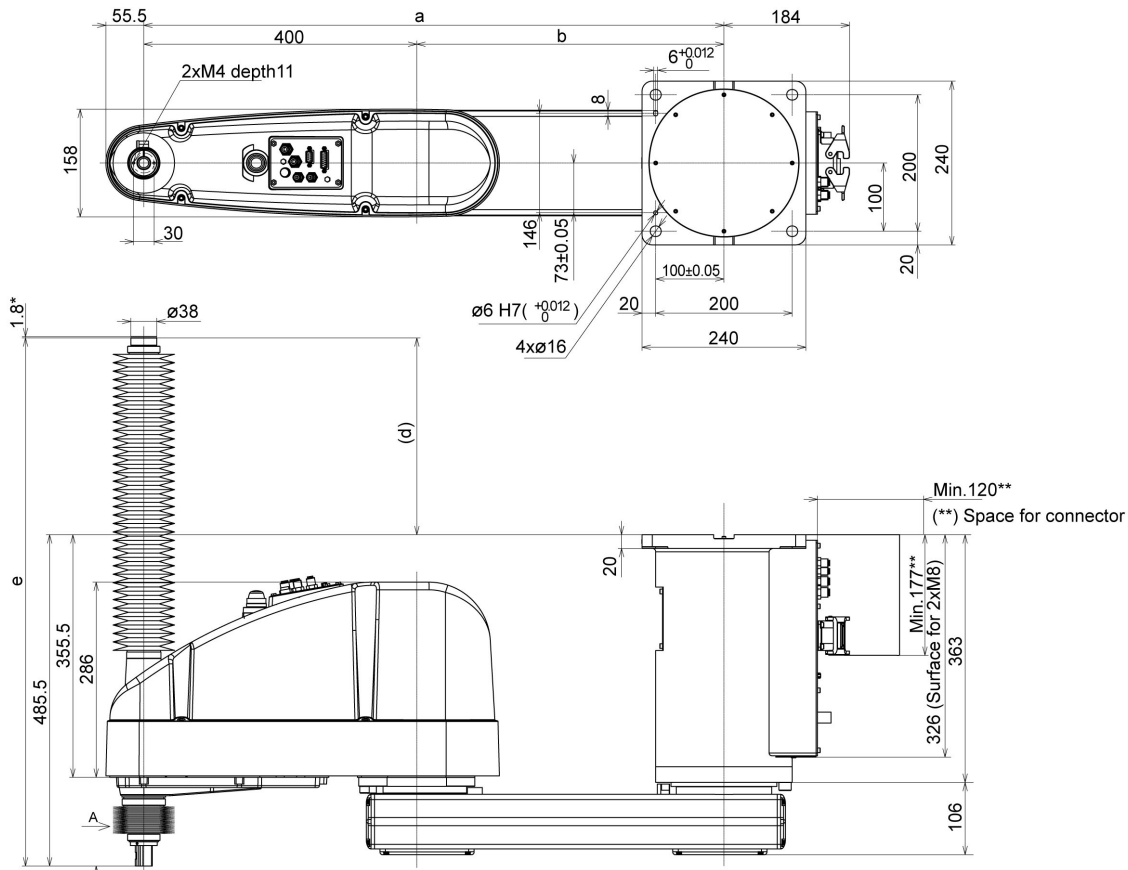

1* (*) Indicates mechanical stop position

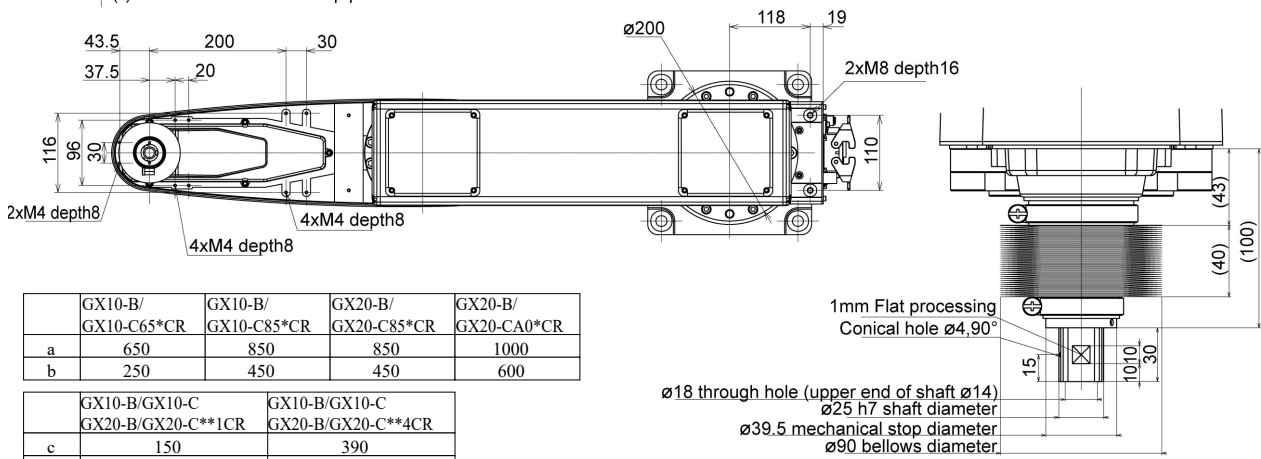

Detail of View A
(Position of origin of joint3 and 4)

	GX10-B/ GX10-C65*CR	GX10-B/ GX10-C85*CR	GX20-B/ GX20-C85*CR	GX20-B/ GX20-CA0*CR
a	650	850	850	1000
b	250	450	450	600

	GX10-B/GX10-C GX20-B/GX20-C**1CR	GX10-B/GX10-C GX20-B/GX20-C**4CR
c	150	390
d	29.5	288.5
e	515	774

Protected-models GX10-B/GX10-C/GX20-B/GX20-C*PR**

The parts shown below differ from the standard specifications.

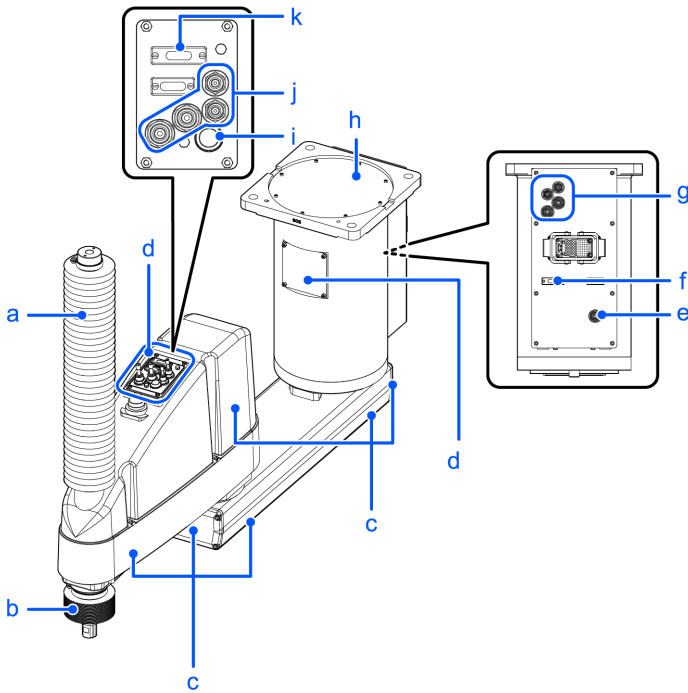

Symbol	Description
a	Upper bellows
b	Lower bellows
c	Plating cover (oil-resistant specifications)
d	Stainless steel plate
e	Exhaust port
f	User connector (protected-model)
g	Fittings with cover (protected-model)
h	Stainless steel plate for ceiling mounting surface
i	Joint #3 and Joint #4 brake release switch (protected-model)
j	Fittings with cover (protected-model)
k	User connector (protected-model)

KEY POINTS

- For protected-models, all screws used for the exterior are stainless steel screws. (except for screws used for stops).
- The part of the M/C cable housing is not IP65 compliant when the M/C cable hood is not connected.

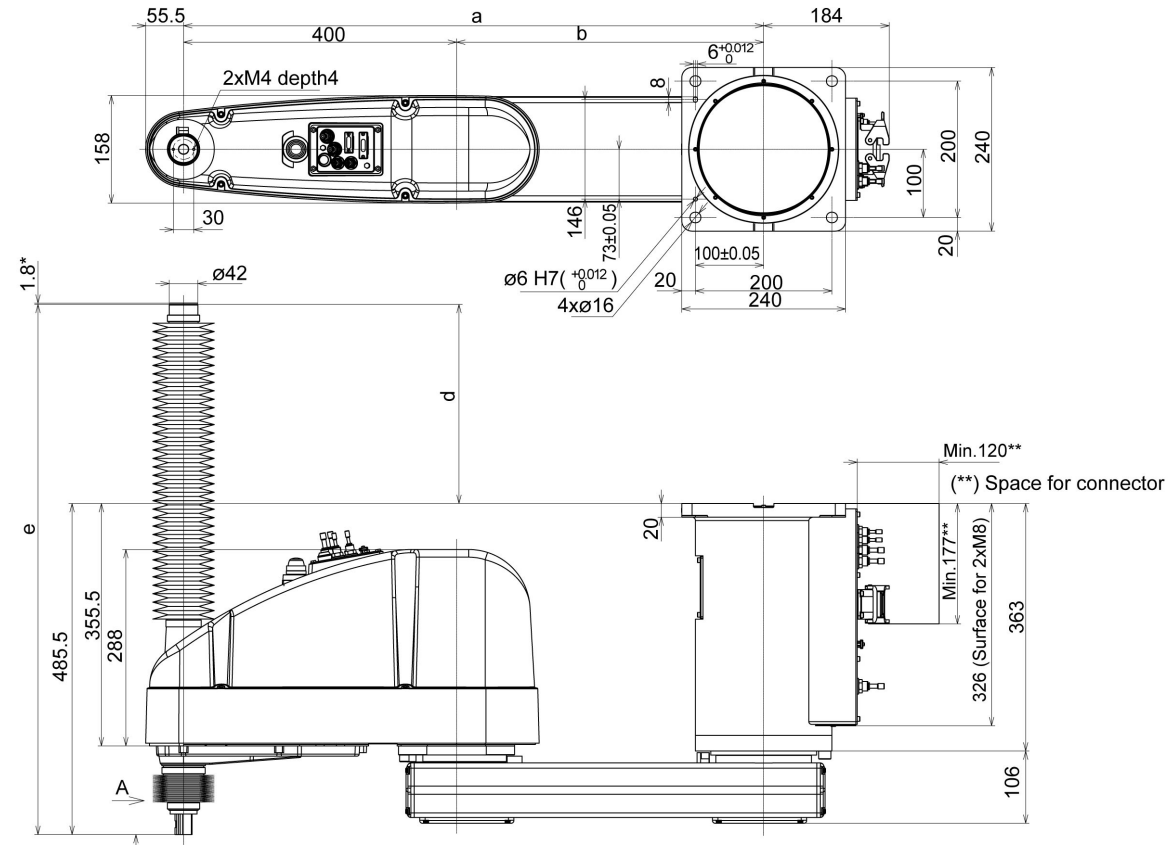

(*) Indicates mechanical stop position

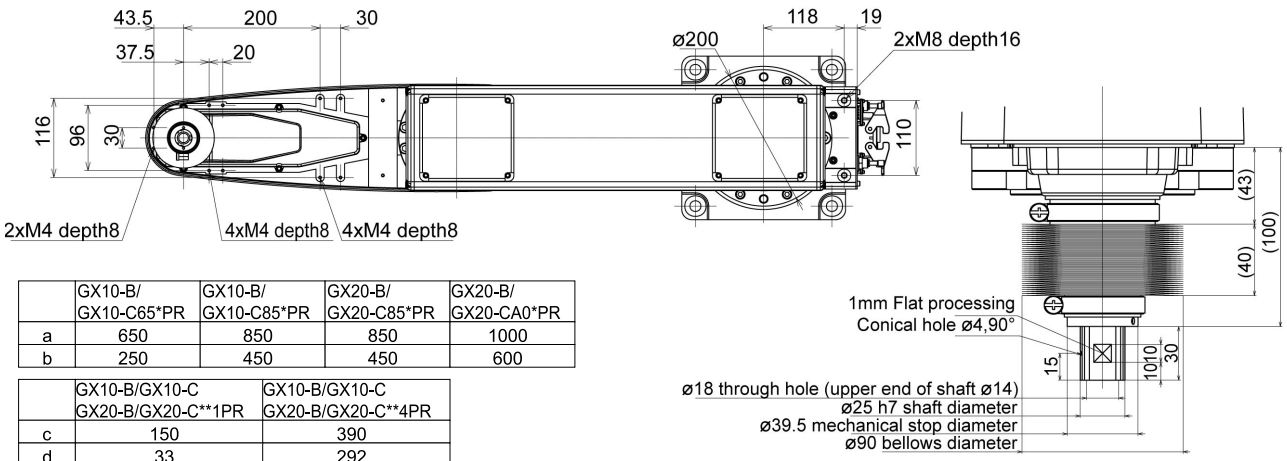

	GX10-B/ GX10-C65*PR	GX10-B/ GX10-C85*PR	GX20-B/ GX20-C85*PR	GX20-B/ GX20-CA0*PR
a	650	850	850	1000
b	250	450	450	600

	GX10-B/GX10-C GX20-B/GX20-C**1PR	GX10-B/GX10-C GX20-B/GX20-C**4PR
c	150	390
d	33	292
e	518.5	777.5

ø18 through hole (upper end of shaft ø14)
 ø25 h7 shaft diameter
 ø39.5 mechanical stop diameter
 ø90 bellows diameter

Detail of View A
 (Position of origin of joint3 and 4)

4.2.4 Specifications Table

For the specifications tables of each model, refer to the following section.

[Appendix A: Specifications Table](#)

4.2.5 How to Set the Model

The Manipulator model for your system has been set before shipment from the factory. Normally, the model does not need to be changed when you receive your system.

CAUTION

- If changing the setting of the Manipulator model, be responsible and absolutely certain that the wrong Manipulator model is not set. Incorrect setting of the Manipulator model may result in abnormal or no operation by the Manipulator and could even cause safety problems.

KEY POINTS

If a custom specifications number (MT***) or (X***) is written on the face plate (serial number label), the Manipulator has custom specifications.

Models with custom specifications may require a different setting procedure. Check the custom specifications number and contact the supplier for more information.

The Manipulator model is set from software. For details, refer to the following manual.
"Epson RC+ User's Guide - Robot Settings"

4.3 Environment and Installation

The robot system should be designed and installed by people who have received installation training provided by Epson and the suppliers. Also, the laws and regulations of the installation country must be followed.

4.3.1 Environment

To ensure that the robot system operates and maintains maximum performance and to ensure its safe use, the Manipulator should be installed in an environment that meets the following requirements.

Item	Requirement
Ambient temperature *1	Installation: 5 to 40°C Transport, storage: - 20 to 60°C
Ambient relative humidity	Installation: 10 to 80% (no condensation) Transport, storage: 10 to 90% (no condensation)
Fast transient burst noise	1 kV or less (signal line)
Electrostatic noise	4 kV or less
Altitude	1000 m or less

 **KEY POINTS**

*1 The ambient temperature requirement is for the Manipulator only. For details on the environment requirements for the connected Controller, refer to the following manual.

"Controller Manual"

 **KEY POINTS**

When used in a low-temperature environment near the minimum temperature specified in the product specifications, or when the unit is idle for a long period of time during holidays or at night, a collision detection error or similar error may occur immediately after the start of operation due to high resistance in the drive unit. In such cases, warm-up operation for about 10 minutes is recommended.

 **KEY POINTS**

If there are conductive objects such as fences or ladders within 2.5 m of the Manipulator, these objects must be grounded.

Also, depending on the environmental specifications of the Manipulator, the following requirements must be met.

Environmental Specifications	Manipulator Installation Environment Requirements
S, C, P	<ul style="list-style-type: none"> ▪ Install indoors. ▪ Keep away from direct sunlight. ▪ Keep away from shocks or vibrations. ▪ Keep away from sources of electric noise. ▪ Keep away from explosive areas. ▪ Keep away from large quantities of radiation.
S, C	<ul style="list-style-type: none"> ▪ Keep away from dust, oily smoke, salinity, metal powder, and other contaminants. ▪ Keep away from flammable or corrosive liquids and gases. ▪ Keep away from water.

The following items should also be taken into consideration for the installation environment of Manipulators with protected-models.

- These are compliant with the IP65 protection class (IEC 60529, JIS C0920). They can be installed in environments exposed to dust or splashing of water.
- They can be installed in environments where dust, oil smoke, metal powder, and similar substances are airborne, but they are not suitable for use with nitrile rubber oil seals, O-rings, packings, liquid gaskets, or other substances that impair sealing performance.
- The Manipulator cannot be used in environments exposed to liquids or airborne droplets that are corrosive such as acids or alkalis.
- In environments that are exposed to airborne droplets containing salt, rust may also form on the Manipulator.
- Manipulator surfaces are generally oil-resistant, but if special oils are to be used, oil resistance should be checked before use. For more information, please contact the supplier.
- In environments with rapid changes in temperature and humidity, condensation may form inside the Manipulator.

- When handling food directly, it is necessary to make sure that the Manipulator is not likely to contaminate the food. For more information, please contact the supplier.
- The Controllers used with Manipulators with protected-models do not have protection against harsh environments. The Controller should be installed in a location that meets its operating environment requirements.

WARNING

Always use a circuit breaker for the Controller's power supply. Failure to use a circuit breaker may result in an electrical shock hazard or malfunction due to an electrical leakage.

Select the correct circuit breaker based on the Controller that you are using. For details, refer to the following manual.

"Controller Manual"

CAUTION

- When cleaning the Manipulator, do not rub it strongly with alcohol or benzene. Coated surfaces may lose their luster.

4.3.2 Base Table

A base table for anchoring the Manipulator is not supplied. The base table must be fabricated or obtained by the customer. The shape and size of the base table vary depending on the application of the robot system. As a reference when designing the base table, the requirements from the Manipulator side are shown here.

The base table must not only be able to bear the weight of the Manipulator but also be able to withstand the dynamic movement of the Manipulator when it operates at maximum acceleration/deceleration. Ensure that the base table has enough strength by using reinforcing materials such as crossbeams.

The torque and reaction force produced by the movement of the Manipulator are as follows:

	GX10-B/GX10-C	GX20-B/GX20-C
Maximum torque on horizontal surface	1000 N·m	1000 N·m
Maximum reaction force in horizontal direction	4500 N	7500 N
Maximum reaction force in vertical direction	2000 N	2000 N

M12 threaded holes are used for mounting the Manipulator on the base table.

Use bolts for mounting the Manipulator that have a strength compliant with ISO 898-1 property class 10.9 or 12.9. The dimensions are provided in the following sections.

Names of Parts and Their Dimensions **Manipulator Mounting Dimensions**

The plate for the Manipulator mounting face should be at least 20 mm thick and made of steel for reducing vibrations. A surface roughness of 25 μm or less at the maximum height is appropriate.

The base table must be secured to the floor or wall to prevent it from moving.

The Manipulator mounting surface should have a flatness of 0.5 mm or less and an inclination of 0.5° or less to a horizontal or vertical surface. If the installation surface does not have the proper flatness, the base of the Manipulator may be damaged or the robot may be unable to operate at maximum performance.

When using a leveler to adjust the height of the base table, use a screw with M16 diameter or more.

If passing cables through the holes in the base table, refer to the connector dimensions in the figures below.

(Units: mm)

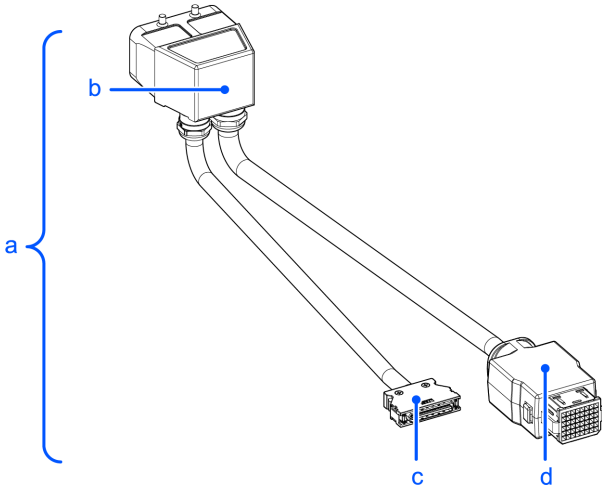

Symbol	Description
a	M/C cable
b	M/C cable hood
c	Signal connector
d	Power connector

Signal Connector	Power Connector (Straight)	Power Connector (L-shaped)

For details on the environmental requirements for the space when housing the Controller in the base table, refer to the following manual.

"Controller Manual"

WARNING

To ensure safety, be sure to install safety barriers for the robot system. For more information on safeguards, refer to the following section.

[Safeguard \(SG\)](#)

4.3.3 Manipulator Mounting Dimensions

The maximum envelope of the Manipulator is shown in the figures below. The maximum envelope shown in each figure shows the case when the radius of the hand is 60 mm or less. If the radius of the hand exceeds 60 mm, define the radius as the distance to the outer edge of the maximum envelope. In addition to the hand, if a camera, solenoid valve, or other component attached to the arm is large, set the maximum envelope to include the range that the component may reach.

Also, besides the area required for installation of the Manipulator, Controller, peripheral equipment, and other devices, the following space should be provided at a minimum.

- Space for teaching
- Space for maintenance and inspection (Space for working safely in the safety barriers)
- Space for cables

KEY POINTS

- When installing the cables, be sure to maintain sufficient distance from obstacles.
- For the minimum bend radius of the M/C cable, refer to the following section.

[GX10/20](#)

- Also, leave enough space for other cables so that they are not forced to bend at extreme angles.

WARNING

Install the Manipulator in a location with enough space so that a tool or a workpiece tip does not reach a wall or safety barriers when the Manipulator extends its arm while holding a workpiece. If the tool or the workpiece tip reaches a wall or safety barriers, it is extremely hazardous and may result in serious bodily injury to operators and/or severe equipment damage.

The distance between the safety barriers and the tool or workpiece should be set according to ISO 10218-2.

For the stopping time and stopping distance, refer to the following sections.

[Appendix B: Stopping Time and Stopping Distance at Emergency Stop](#)

[Appendix C: Stopping Time and Stopping Distance When Safeguard is Open](#)

Table top mounting specifications

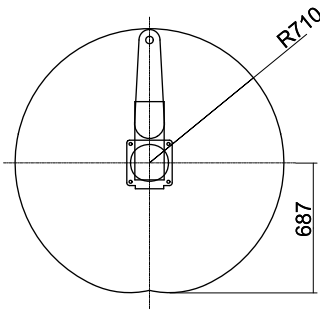

GX10-B/GX10-C65**

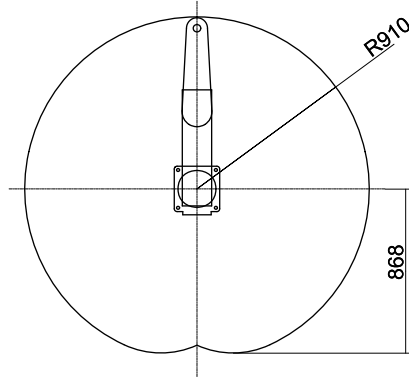

GX10-B/GX10-C
GX20-B/GX20-C85**

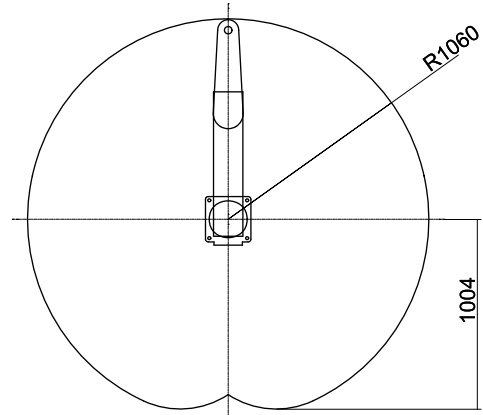

GX20-B/GX20-CA0**

Wall mounting specifications

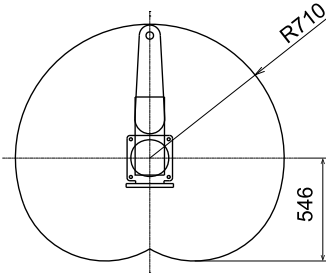

GX10-B/GX10-C65**W

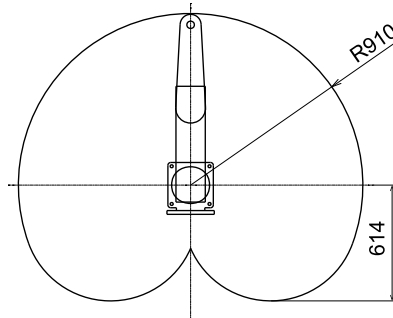

GX10-B/GX10-C
GX20-B/GX20-C85**W

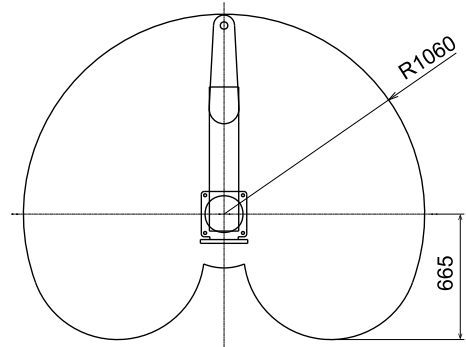

GX20-B/GX20-CA0**W

Ceiling mounting specifications

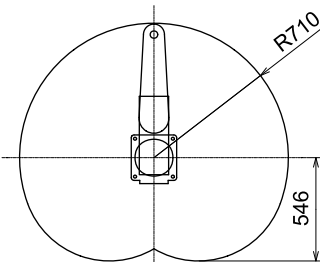

GX10-B/GX10-C65**R

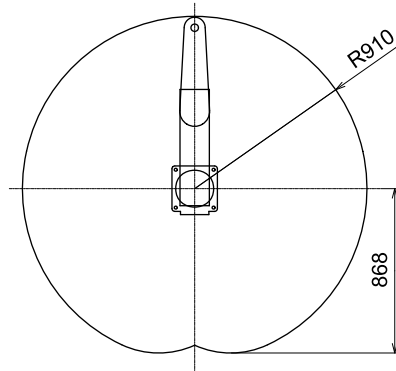

GX10-B/GX10-C
GX20-B/GX20-C85**R

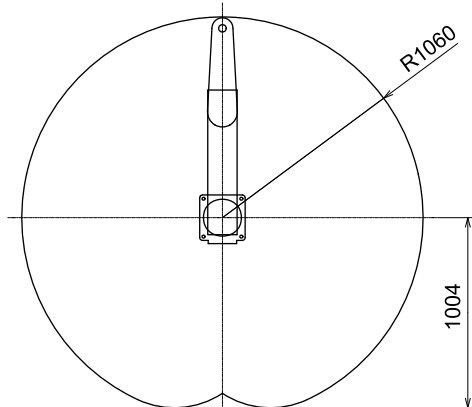

GX20-B/GX20-CA0**R

4.3.4 From Unpacking to Installation

4.3.4.1 Safety Information for the Flow from Unpacking to Installation

Transportation and installation of the Manipulator and related equipment should be performed by people who have received installation training provided by Epson and the suppliers. Also, the laws and regulations of the installation country must be followed.

⚠ WARNING

- Only qualified personnel should perform sling work and operate a crane or a forklift. When these operations are performed by unqualified personnel, it is extremely hazardous and may result in serious bodily injury to operators and/or severe equipment damage.

⚠ CAUTION

- Use a cart or the like to transport the Manipulator in the same status as it was delivered.
- After removing the fixing bolts securing the Manipulator to the transportation pallet, the Manipulator can fall. Be careful not to get your hands or feet caught in between the Manipulator.
- The arm is secured in place with cable ties or similar restraints. To prevent hands or other body parts from getting pinched in the robot arm, do not remove the cable ties until installation is complete.
- When transported, the Manipulator should either be secured to transporting equipment or carried by three or more people with hands placed under the shaded sections (under Arm #1 and bottom of base). When holding the bottom of the base by hand, be extremely careful not to get your hands or fingers caught.

When transporting the Manipulator by hoisting, refer to the following:
"Transporting the Manipulator by Hoisting"

Table Top Mounting Specifications

- GX10-B/GX10-C65** : Approx.46 kg (102 lb)
- GX10-B/GX10-C/GX20-B/GX20-C85** : Approx.49 kg (108 lb)
- GX20-B/GX20-CA0** : Approx.50 kg (111 lb)

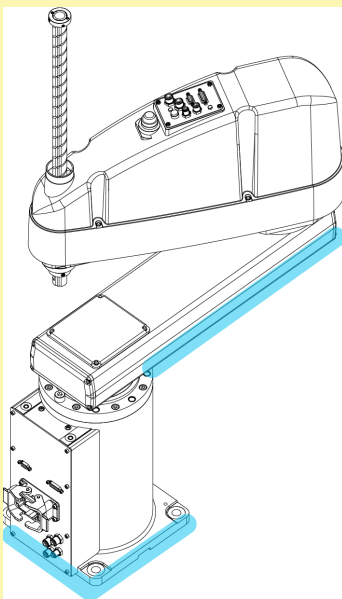

Wall Mounting Specifications

- GX10-B/GX10-C65**W : Approx.51 kg (113 lb)

- GX10-B/GX10-C/GX20-B/GX20-C85**W: Approx.53 kg (117 lb)
- GX20-B/GX20-CA0**W: Approx.55 kg (122 lb)

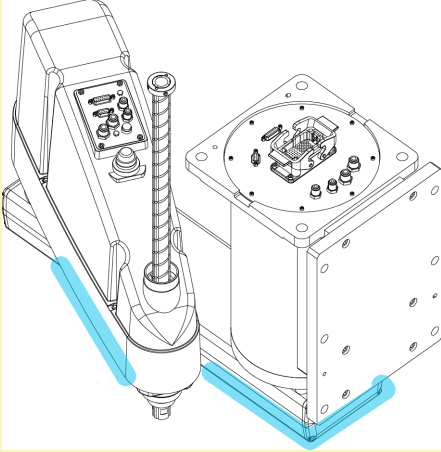

Ceiling Mounting Specifications

- GX10-B/GX10-C65**R: Approx.46 kg (102 lb)
- GX10-B/GX10-C/GX20-B/GX20-C85**R: Approx.49 kg (108 lb)
- GX20-B/GX20-CA0**R: Approx.50 kg (111 lb)

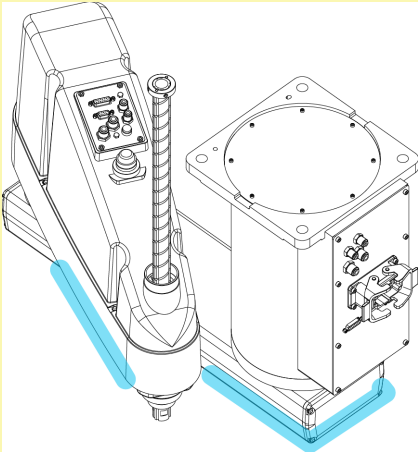

- When transporting the Manipulator over long distances, secure it directly to transporting equipment so that it will not fall. If necessary, pack the Manipulator using the same packaging as delivery.
- The Manipulator must be installed to avoid interference with surrounding buildings, structures, and other machines and equipment that may create a trapping hazard or pinch points.
- Resonance (resonating sound or minute vibrations) may occur during Manipulator operation depending on the rigidity of the base table. If the resonance occurs, improve the rigidity of the base table or change the speed or acceleration and deceleration settings of the Manipulator.

For details on the Manipulator installation procedure for models with standard specifications, refer to the following sections.

- "Table Top Mounting Specifications"
- "Wall Mounting Specifications"
- "Ceiling Mounting Specifications"

For Manipulator models with cleanroom & ESD specifications and with protected-model, refer to the following sections.

- "Cleanroom & ESD Specifications"
- "Protected-Model"

Transporting the Manipulator by Hoisting

Follow the procedure below.

1. Attach the eyebolts to the top of the Manipulator base as shown in the figure below.
2. Place the Manipulator arm in the extended position.
3. Ensure that the hoisting belt can be secured to Arm #2. Using the metal part of the shaded area as a guide, apply the band so that it does not shift.

KEY POINTS

Please note that the plastic cover section may be damaged if a load is applied to it.

4. To prevent the Manipulator from falling over, lift while providing support at the position indicated by the arrow, and move it to the base table where it will be installed.

Table Top Mounting Specifications

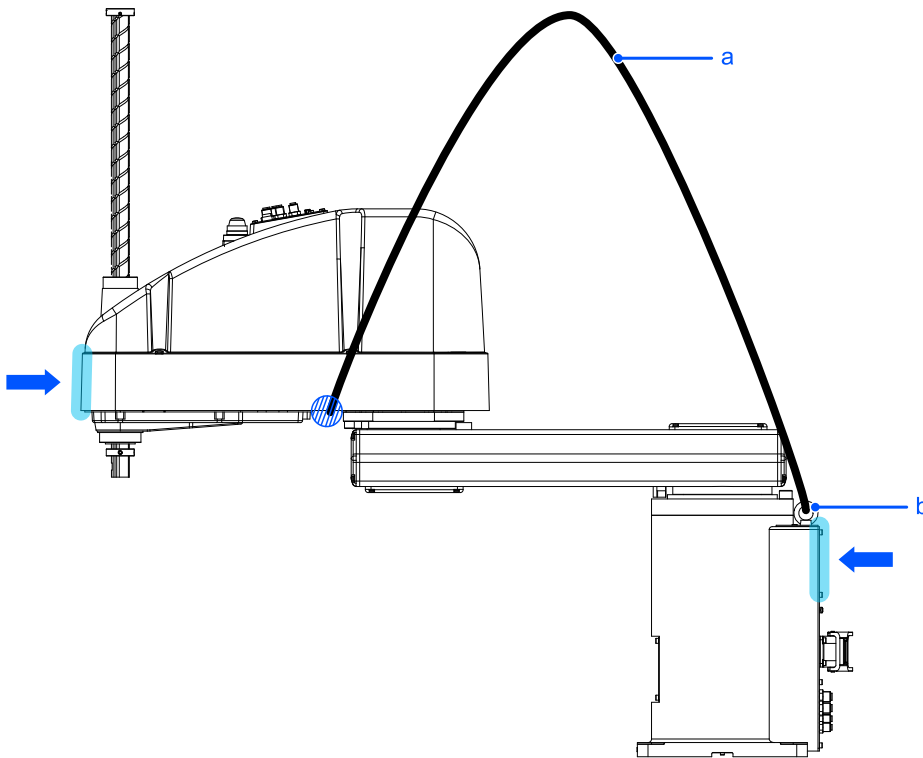

Symbol	Description
a	Hoisting belt
b	M8 eyebolts: 2 (included)

Wall mounting specifications, ceiling mounting specifications

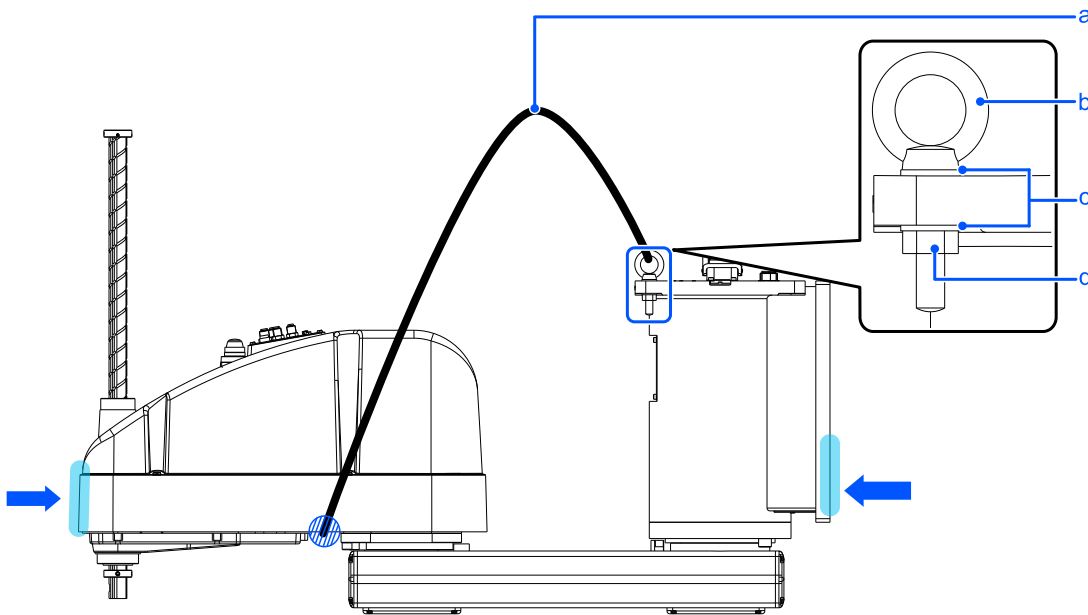

Symbol	Description
a	Hoisting belt
b	M10 eyebolts: 2 (included)
c	Plain washers: 2 (included)
d	Nuts: 2 (included)

4.3.4.2 Table Top Mounting Specifications

⚠ CAUTION

Be sure to use four or more people when installing or relocating a model with table top mounting specifications, and use three or more people when lifting a Manipulator. The Manipulator weights are as follows. Be careful not to get hands or feet caught or have equipment damaged due to dropping of the Manipulator.

- GX10-B/GX10-C65**: Approx.46 kg (102 lb)
- GX10-B/GX10-C/GX20-B/GX20-C85**: Approx.49 kg (108 lb)
- GX20-B/GX20-CA0**: Approx.50 kg (111 lb)

Standard-model

1. Secure the base to the base table using four bolts. Be sure to always use washers.

Tightening torque:

- 100.0 N·m (1,020 kgf·cm)

✎ KEY POINTS

Use bolts with strength specifications compliant with ISO 898-1 property class: 10.9 or 12.9.

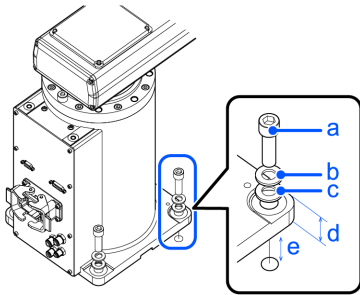

Symbol	Description
a	4 × M12 × 40
b	Spring washer
c	Plain washer
d	20 mm
e	Threaded hole (20 mm or more depth)

2. Use a nippers or similar tool to cut the cable ties holding the arm in place.

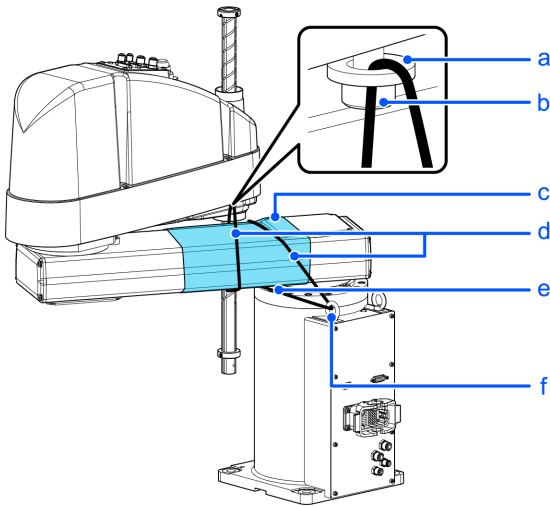

Symbol	Description
a	Washer
b	Bolt: M4 × 15
c	Sheet
d	Cable tie
e	Bolt: M12 (transportation fixture)
f	Eyebolts (included)

3. Remove the bolts that secured the cable ties in step 2.

4. Remove the transportation fixtures.

4.3.4.3 Wall Mounting Specifications

⚠ WARNING

- Be sure to use four or more people when installing or relocating a model with wall mounting specifications, and use three or more people when lifting a Manipulator. The Manipulator weights are as follows. Be careful not to get hands or feet caught or have equipment damaged due to dropping of the Manipulator.
 - GX10-B/GX10-C65**W: Approx.51 kg (113 lb)
 - GX10-B/GX10-C/GX20-B/GX20-C85**W: Approx.53 kg (117 lb)
 - GX20-B/GX20-CA0**W: Approx.55 kg (122 lb)
- When installing the Manipulator on a wall or similar structure, support the Manipulator until all of the anchor bolts are secured in place. Removing the support before the anchor bolts are fully secured is extremely hazardous and may cause the Manipulator to fall.

Standard specifications

1. With the arm extended, take out the Manipulator from the packing box.

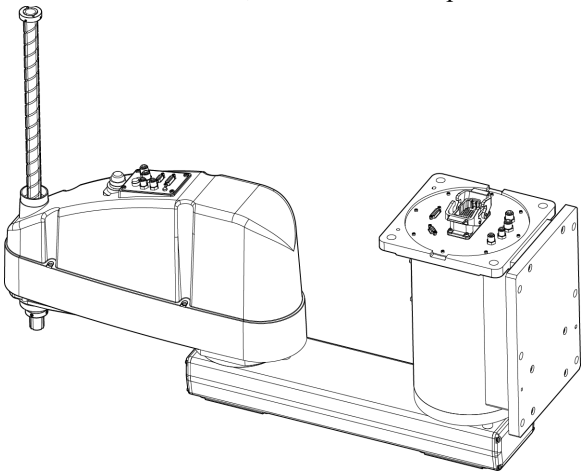

✍ KEY POINTS

The joints may rotate due to the Manipulator's own weight. Be careful not to get your hands or fingers caught.

2. Secure the base to the wall using the six bolts.
 Be sure to always use washers.
 Tightening torque: 100.0 N·m (1,020 kgf·cm)

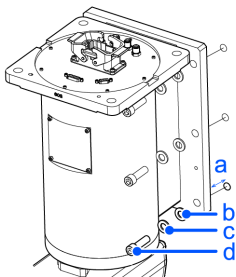

Symbol	Description
a	Threaded hole (20 mm or more depth)

Symbol	Description
b	Plain washer
c	Spring washer
d	6 × M12 × 40

KEY POINTS

Use bolts with strength specifications compliant with ISO 898-1 property class: 10.9 or 12.9.

3. Remove the transportation fixtures.

4.3.4.4 Ceiling Mounting Specifications

WARNING

- Be sure to use four or more people when installing or relocating a model with ceiling mounting specifications, and use three or more people when lifting a Manipulator. The Manipulator weights are as follows. Be careful not to get hands or feet caught or have equipment damaged due to dropping of the Manipulator.
 - GX10-B/GX10-C65**R: Approx.46 kg (102 lb)
 - GX10-B/GX10-C/GX20-B/GX20-C85**R: Approx.49 kg (108 lb)
 - GX20-B/GX20-CA0**R: Approx.50 kg (111 lb)
- When installing the Manipulator on a ceiling or similar structure, support the Manipulator until all of the anchor bolts are secured in place. Removing the support before the anchor bolts are fully secured is extremely hazardous and may cause the Manipulator to fall.

Standard specifications

1. With the arm extended, take out the Manipulator from the packing box.

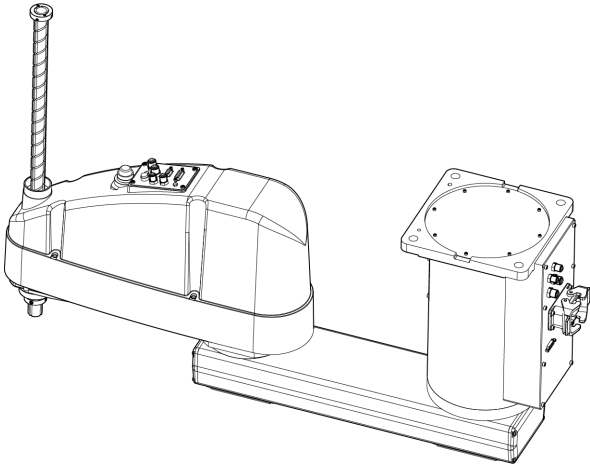

KEY POINTS

The joints may rotate due to the Manipulator's own weight. Be careful not to get your hands or fingers caught.

2. Secure the base to the ceiling using the four bolts. Be sure to always use washers.

Tightening torque:

- 100.0 N·m (1,020 kgf·cm)

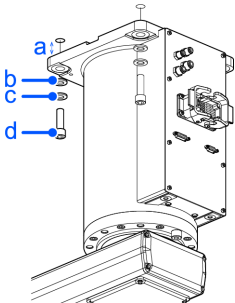

Symbol	Description
a	Threaded hole (20 mm or more depth)
b	Plain washer
c	Spring washer
d	6 × M12 × 40

KEY POINTS

Use bolts with strength specifications compliant with ISO 898-1 property class: 10.9 or 12.9.

3. Remove the transportation fixtures.

4.3.4.5 Cleanroom & ESD-Model

1. Unpack the Manipulator outside of the cleanroom.
2. Secure the Manipulator to transporting equipment (or a pallet) with bolts so that the Manipulator does not fall down.
3. Wipe off any dust on the Manipulator using a lint-free cloth that was dipped in ethyl alcohol or distilled water.
4. Carry the Manipulator into the cleanroom.
5. Refer to the installation procedure for the respective Manipulator model, and install the Manipulator.
 - Table Top Mounting Specifications
 - Wall Mounting Specifications
 - Ceiling Mounting Specifications
6. Connect an exhaust tube to the exhaust port.

When the Manipulator is a model with cleanroom & ESD specifications, an exhaust system must be connected. For details, refer to the following section.

[Appendix A: Specifications Table](#)

4.3.4.6 Protected-Model

Refer to the installation procedure for the respective Manipulator model, and install the Manipulator.

Table Top Mounting Specifications

Wall Mounting Specifications

Ceiling Mounting Specifications

When the Manipulator is a protected-model, take note of the following safety information.

WARNING

- After the Manipulator is installed, immediately connect the M/C cable connector to the Manipulator. Leaving the Manipulator unconnected may result in electric shock and/or malfunction of the robot system because protection at IP65 cannot be ensured.

CAUTION

- When operating Manipulators in special environments (oil smoke, dust, etc.), do not install the Controller in the same environment. The Controller does not satisfy the protection class (IP65). Using the Controller in these special environments may damage or lead to a breakdown of the Controller.

4.3.5 Connecting the Cables

WARNING

- To perform the power supply lockout, remove the power plug. Be sure to connect the AC power cable to a power outlet. Do not connect it directly to a factory power source.
- Before performing any replacement work, inform others in the area that you are working, and then turn off the Controller and related equipment, and unplug the power cable from the power source. Performing any work procedure with the power turned on is extremely dangerous and may result in electric shock and/or malfunction of the robot system.
- Be sure to connect the cables properly. Do not place heavy objects on the cables, bend them at extreme angles, pull them forcibly, or allow them to get pinched between objects. Damaged cables, broken wires, or contact failure is extremely hazardous and may result in electric shock and/or malfunction of the robot system.
- The Manipulator is grounded by connecting it to the Controller. Ensure that the Controller is grounded and the cables are correctly connected. If the ground wire is improperly connected to ground, it may result in the fire or electric shock.

CAUTION

- When connecting the Manipulator and the Controller, check that the serial numbers match for each device. Improper connection between the Manipulator and the Controller may not only lead to malfunction of the robot system but also serious safety problems. The connection method between the Manipulator and the Controller varies depending on the Controller. For details on the connections, refer to the following manual.

"Controller Manual"

When the Manipulator is a model with cleanroom & ESD specifications, please note the following points.

When the Manipulator is a model with cleanroom & ESD specifications, an exhaust system must be connected. For details, refer to the following section.

[Appendix A: Specifications Table](#)

When the Manipulator is a protected-model, please note the following points.

WARNING

- After the Manipulator is installed, immediately connect the M/C cable connector to the connector plate. Leaving the Manipulator unconnected may result in electric shock and/or malfunction of the robot system because protection at IP65 cannot be ensured.

CAUTION

- When operating Manipulators in special environments (oil smoke, dust, etc.), do not install the Controller in the same environment. The Controller does not satisfy the protection class (IP65). Using the Controller in these special environments may damage or lead to a breakdown of the Controller.

Connection procedure for Manipulator and M/C cable

Insert the M/C cable hood into the M/C cable housing on the back and bottom of the Manipulator, and secure it with the lock attached to the housing.

1. Open the lock plates on both sides of the M/C cable housing.
2. Insert the M/C cable hood all the way to the back.
3. Close the lock plates on both sides of the M/C cable housing.

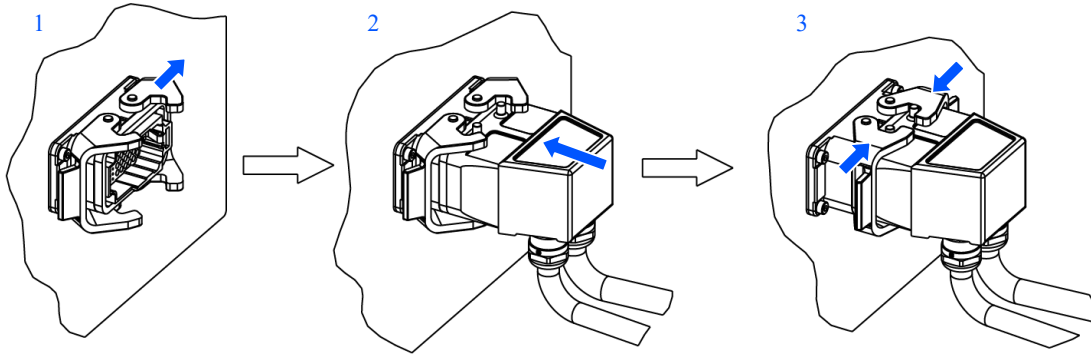

L-shape (Standard)		Straight	
Minimum Distance Required for Insertion and Removal	Distance When Mounted	Minimum Distance Required for Insertion and Removal	Distance When Mounted

Connecting the M/C cable and the Controller

Connect the power connector and signal connector of the M/C cable to the Controller.

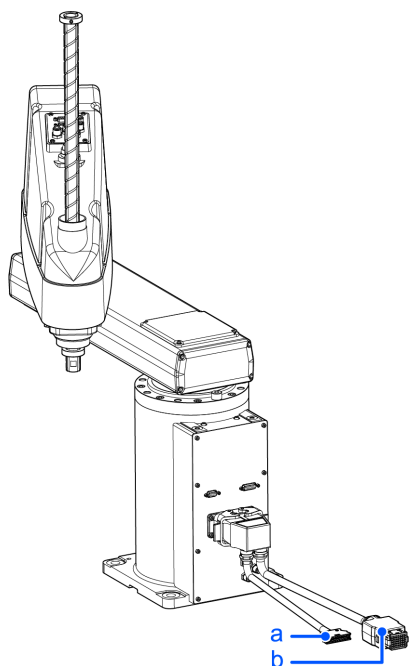

Symbol	Description
a	Signal connector
b	Power connector

There are two types of M/C cables: fixed and movable. Movable cables have wires as shown in the figure below.



4.3.6 User Wires and Pneumatic Tubes

⚠ CAUTION

- Only authorized or certified personnel should perform wiring. Wiring by unauthorized or uncertified staff may result in bodily injury and/or malfunction of the robot system.

4.3.6.1 Electrical Wires

Connect the following connectors and cables to the user connector of the Manipulator.

Manipulator cable specifications

	Rated Voltage	Allowable Current	Nominal Cross-sectional Area of Conductor	Remarks
D-sub 15 pin D-sub 9 pin	AC/DC 30 V	1.0 A	0.08 mm ²	Shielded

For each connector, pins with the same number are wired between the connector on the base side and the connector on the Arm #2 side in the Manipulator.

Connectors to the Manipulator (recommended)

Standard, cleanroom & ESD specifications

		Manufacturer	Model Number	Type	Remarks
D-sub 15 pin	Connector	Würth Elektronik	61801524823	Solder type	2 included
	Clamp hood	Würth Elektronik	61801525311	Connector setscrew: #4-40 UNC	2 included
D-sub 9 pin	Connector	Würth Elektronik	61800924823	Solder type	2 included
	Clamp hood	Würth Elektronik	61800925311	Connector setscrew: #4-40 UNC	2 included

Protected-Model

		Manufacturer	Model Number	Type	Remarks
D-sub 15-pin	Connector	HARTING	09670155615	Solder type	2 included
	Clamp hood	HARTING	09670150538	Connector setscrew: #4-40 UNC	2 included
D-sub 9-pin	Connector	HARTING	09670095615	Solder type	2 included
	Clamp hood	HARTING	09670090538	Connector setscrew: #4-40 UNC	2 included

4.3.6.2 Pneumatic Tubes

Manipulator pneumatic tube specifications

Maximum Working Pressure	Number of Tubes	O.D. × I.D.
0.59 MPa (6 kgf/cm ² : 86 psi)	2	ø6 mm × ø4 mm
	302	ø4 mm × ø2.5 mm

For each connector inside the Manipulator, fittings of the same size and tip color (blue/white) are connected between the air fitting on the base side and the air fitting on the Arm #2 side.

Pneumatic tubes connected to the Manipulator (recommended)

Outer Diameter	Manufacturer	Model Number	Remarks
ø6 mm	SMC	TU0604*	Equivalent products from other companies can be used
ø4 mm	SMC	TU0425*	Equivalent products from other companies can be used

When the Manipulator is a protected-model, please note the following points.

⚠ CAUTION

- In special environments (e.g., oil smoke, dust, etc.), the user wires and pneumatic tubes should have protected-model (compliant with protection class IP65). If the user wires and pneumatic tubes without protected-model are connected, the protection class (IP65) cannot be guaranteed, and the Manipulator may be damaged or break down.
- Be sure to always connect the cap when the user cable connector is not being used.

If the cap is not attached, foreign matter such as oil smoke or dust may enter the connector, causing the Manipulator to be damaged or break down.

Arm #2 side (common)

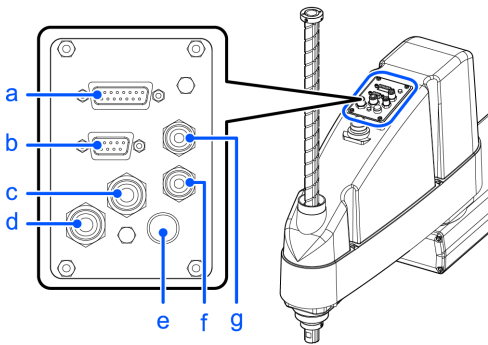

Symbol	Description
a	15-pin D-sub connector
b	9-pin D-sub connector
c	Fitting for ø6 mm tube (blue)
d	Fitting for ø6 mm tube (white)
e	Brake release switch
f	Fitting for ø4 mm tube (white)
g	Fitting for ø4 mm tube (blue)

Base side (table top mounting specifications)

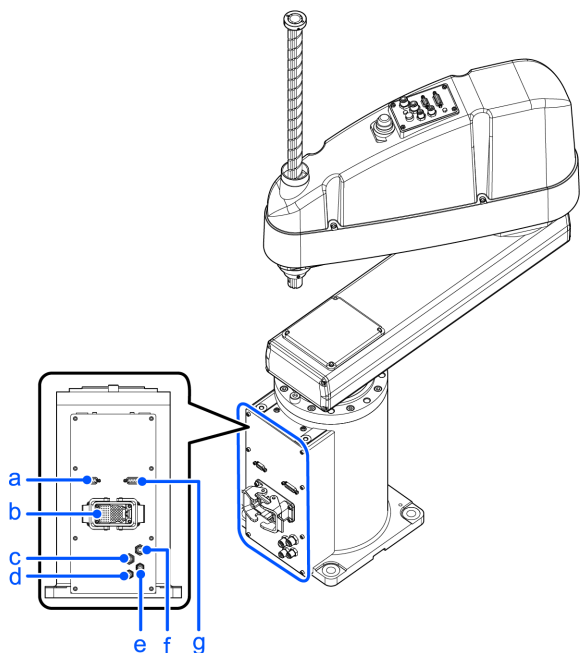

Symbol	Description
a	User connector (9-pin D-sub connector)
b	M/C cable housing
c	Fitting for ø6 mm tube (blue)
d	Fitting for ø4 mm tube (blue)
e	Fitting for ø4 mm tube (white)
f	Fitting for ø6 mm tube (white)
g	User connector (15-pin D-sub connector)

Base side (wall mounting specifications)

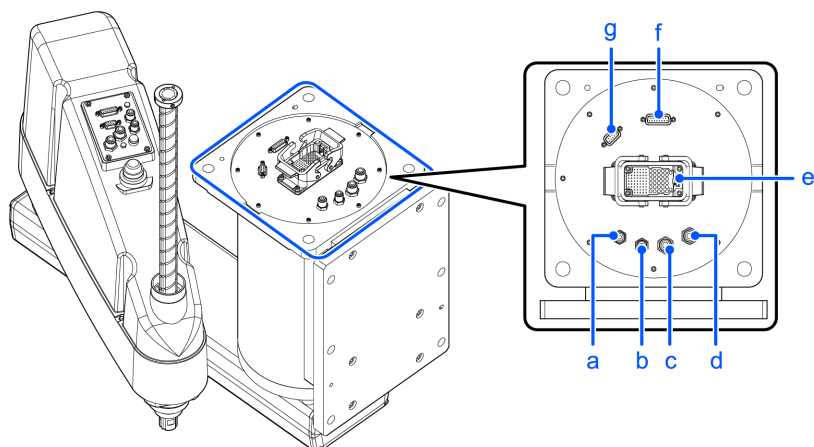

Symbol	Description
a	Fitting for ø4 mm tube (blue)
b	Fitting for ø4 mm tube (white)
c	Fitting for ø6 mm tube (blue)

Symbol	Description
d	Fitting for ø6 mm tube (white)
e	M/C cable housing
f	User connector (15-pin D-sub connector)
g	User connector (9-pin D-sub connector)

Base side (ceiling mounting specifications)

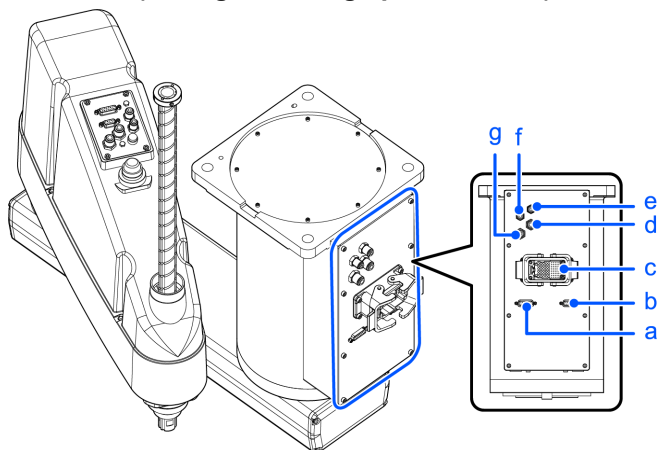

Symbol	Description
a	User connector (15-pin D-sub connector)
b	User connector (9-pin D-sub connector)
c	M/C cable housing
d	Fitting for ø6 mm tube (blue)
e	Fitting for ø4 mm tube (blue)
f	Fitting for ø4 mm tube (white)
g	Fitting for ø6 mm tube (white)

4.3.7 Relocation and Storage

4.3.7.1 Safety Information for Relocation and Storage

Pay attention to the following requirements when relocating, storing, and transporting the Manipulators.

Transportation and installation of the Manipulator and related equipment should be performed by people who have received

installation training provided by Epson and the suppliers. Also, the laws and regulations of the installation country must be followed.

WARNING

- Only qualified personnel should perform sling work and operate a crane or a forklift. When these operations are performed by unqualified personnel, it is extremely hazardous and may result in serious bodily injury to operators and/or severe equipment.

CAUTION

- Before relocating, fold the arm and secure it tightly with a cable tie to prevent hands or fingers from getting caught in the Manipulator.
- When removing the anchor bolts, support the Manipulator so that it does not fall. Removing the anchor bolts without supporting the Manipulator can cause it to fall, causing hands or feet to get caught.
- The Manipulator should be transported by three or more people, either secured to transporting equipment or carried by placing their hands under Arm #1 or the bottom of the base. When holding the bottom of the base by hand, be extremely careful not to get your hands or fingers caught.

When transporting the Manipulator over long distances, secure it directly to transporting equipment so that it will not fall. If necessary, pack the Manipulator using the same packaging as delivery.

When the Manipulator is reassembled and used for a robot system again after an extended period of storage, perform a test run to verify that it works properly before starting the main operation.

Manipulators should be transported and stored under the following conditions: Temperature: -20 to +60°C, Humidity: 10 to 90% (no condensation)

If condensation has formed on the Manipulator during transportation or storage, do not turn on the power until the condensation is removed.

Do not subject the Manipulator to excessive impacts or vibrations during the transportation process.

4.3.7.2 Table Top Mounting Specifications

CAUTION

- Be sure to use four or more people when installing or relocating a model with table top mounting specifications, and use three or more people when lifting a Manipulator. The Manipulator weights are as follows. Be careful not to get hands or feet caught or have equipment damaged due to dropping of the Manipulator.
 - GX10-B/GX10-C65**: Approx.46 kg (102 lb)
 - GX10-B/GX10-C/GX20-B/GX20-C85**: Approx.49 kg (108 lb)
 - GX20-B/GX20-CA0**: Approx.50 kg (111 lb)

1. Turn off all power, and remove the wiring and tubes connected to the Manipulator.

KEY POINTS

If using variable mechanical stops for Joints #1 and #2 and the operating angle is limited, change to the mechanical stop positions at factory shipping.

Setting the Work Envelope by Mechanical Stops

2. Attach the eyebolts to the top back of the Manipulator.
3. Bind the lower end of the shaft to the arm and the base to the arm.
Using a cable tie or similar material, bind tightly enough that the shaft does not sag down.

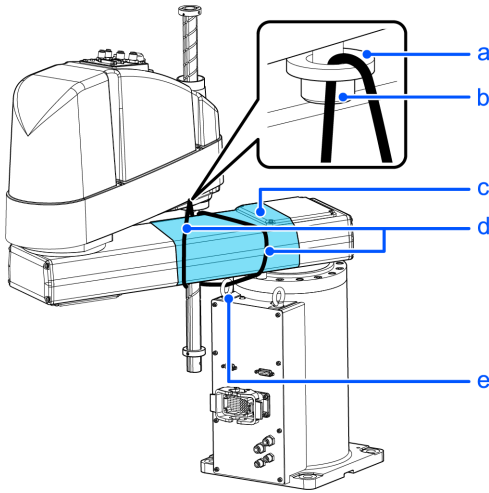

Symbol	Description
a	Washer:
b	Bolt: M4 × 15
c	Sheet
d	Cable tie
f	Eyebolts (included)

4. While supporting the bottom of Arm #1 by hand so that the Manipulator does not fall over, remove the anchor bolts. Then, remove the Manipulator from the base table.

GX10-B/GX10-C65**

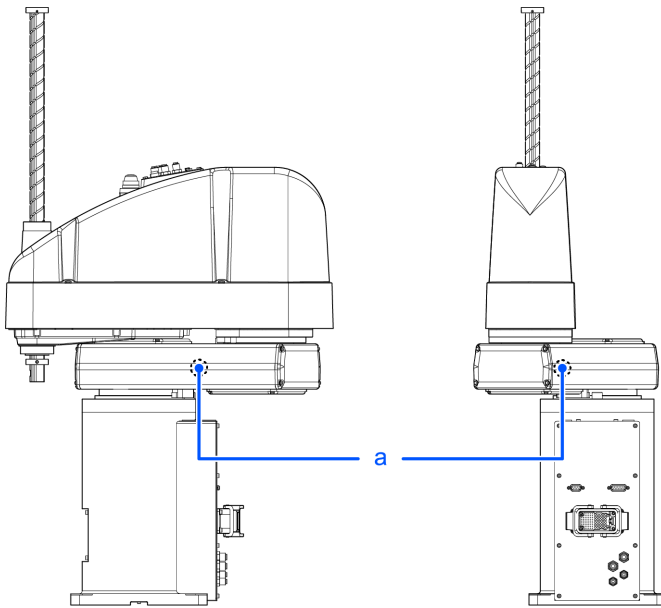

Symbol	Description
a	Center of gravity

GX10-B/GX10-C/GX20-B/GX20-C85**

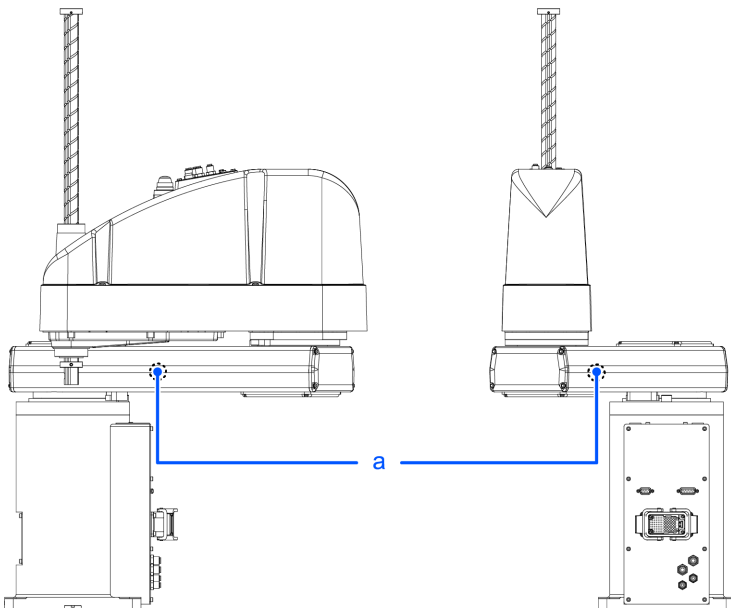

Symbol	Description
a	Center of gravity

GX20-B/GX20-CA0**

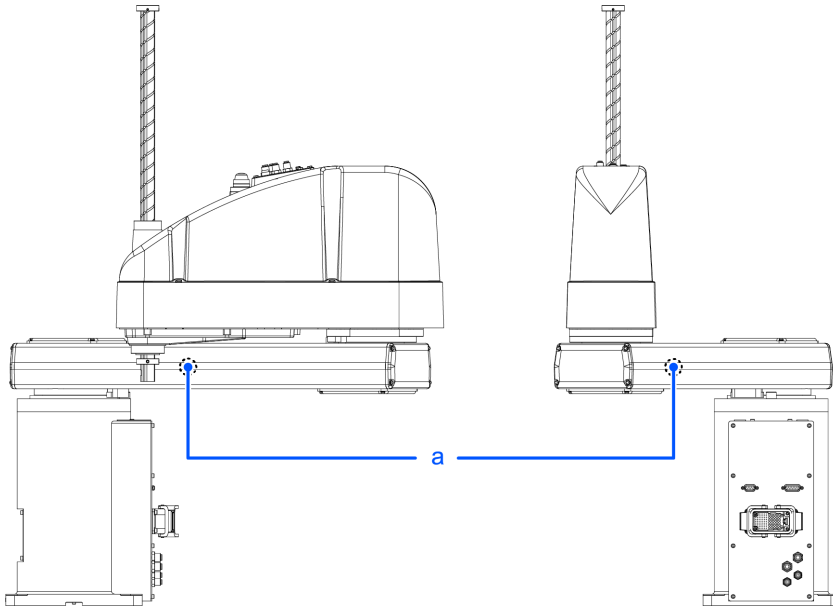

Symbol	Description
a	Center of gravity

4.3.7.3 Wall Mounting Specifications

WARNING

- Be sure to use four or more people when installing or relocating a model with wall mounting specifications, and use three or more people when lifting a Manipulator. The Manipulator weights are as follows. Be careful not to get hands or feet caught or have equipment damaged due to dropping of the Manipulator.
 - GX10-B/GX10-C65**W: Approx.51 kg (113 lb)
 - GX10-B/GX10-C/GX20-B/GX20-C85**W: Approx.53 kg (117 lb)
 - GX20-B/GX20-CA0**W: Approx.55 kg (122 lb)
- When removing the Manipulator from a wall or other location, be sure to support the Manipulator before removing the anchor bolts. Removing the anchor bolts without supporting the Manipulator is extremely hazardous and may cause the Manipulator to fall.

1. Turn off all power, and remove the wiring and tubes connected to the Manipulator.

KEY POINTS

If using variable mechanical stops for Joints #1 and #2 and the operating angle is limited, change to the mechanical stop positions at factory shipping.

[Setting the Work Envelope by Mechanical Stops](#)

2. Wrap a sheet around the arm so that it will not get damaged. Secure the arm while referring to the figure.

Example of securing arm in place

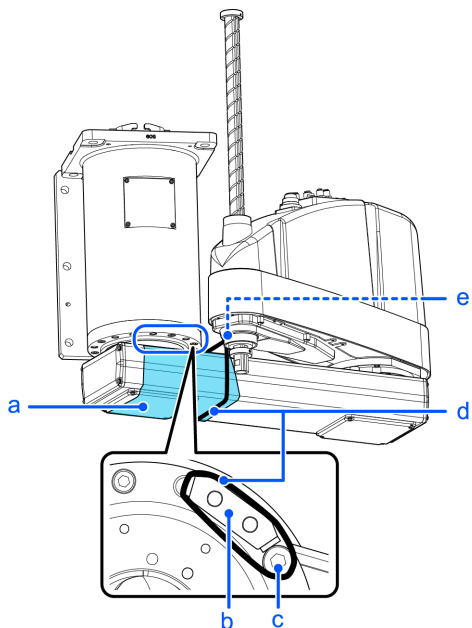

Symbol	Description
a	Sheet
b	Arm #1 stop bolt
c	Arm fixing bolt
d	Cable tie
e	Bolt: M4 × 15 Washer

3. While supporting the bottom of Arm #1 by hand so that the Manipulator does not fall over, remove the anchor bolts. Then, remove the Manipulator from the wall.

GX10-B/GX10-C65W**

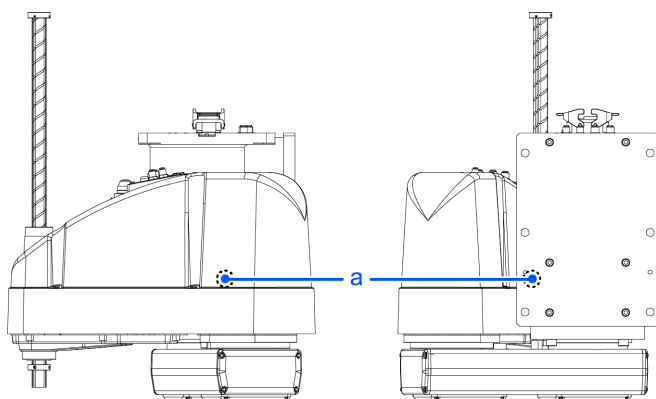

Symbol	Description
a	Center of gravity

GX10-B/GX10-C/GX20-B/GX20-C85W**

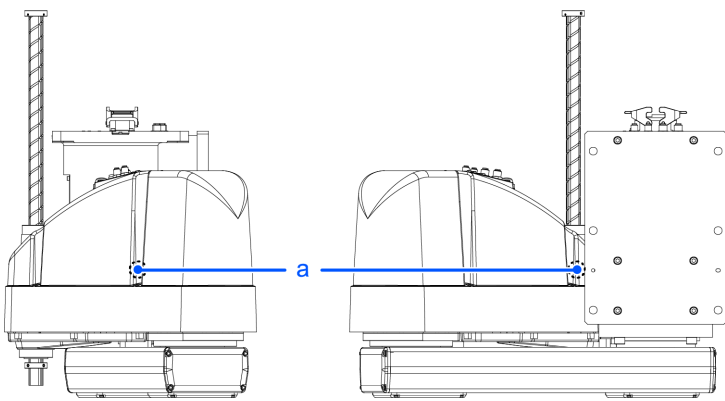

Symbol	Description
a	Center of gravity

GX20-B/GX20-CA0W**

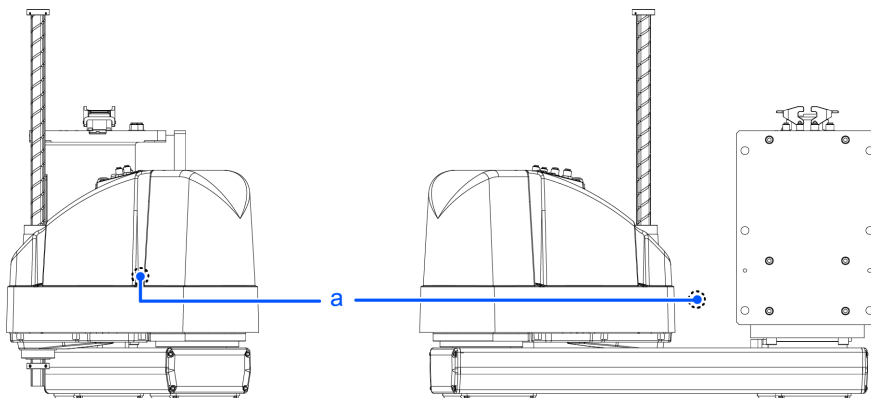

Symbol	Description
a	Center of gravity

4.3.7.4 Ceiling Mounting Specifications

⚠ WARNING

- Be sure to use four or more people when installing or relocating a model with ceiling mounting specifications, and use three or more people when lifting a Manipulator. The Manipulator weights are as follows. Be careful not to get hands or feet caught or have equipment damaged due to dropping of the Manipulator.
 - GX10-B/GX10-C65**R: Approx.46 kg (102 lb)
 - GX10-B/GX10-C/GX20-B/GX20-C85**R: Approx.49 kg (108 lb)
 - GX20-B/GX20-CA0**R: Approx.50 kg (111 lb)
- When removing the Manipulator from a ceiling surface or other location, be sure to support the Manipulator before removing the anchor bolts. Removing the anchor bolts without supporting the Manipulator is extremely hazardous and may cause the Manipulator to fall.

1. Turn off all power, and remove the wiring and tubes connected to the Manipulator.

✍ KEY POINTS

If using variable mechanical stops for Joints #1 and #2 and the operating angle is limited, change to the mechanical stop positions at factory shipping.

Setting the Work Envelope by Mechanical Stops

2. Wrap a sheet around the arm so that it will not get damaged. Secure the arm while referring to the figure.

Example of securing arm in place

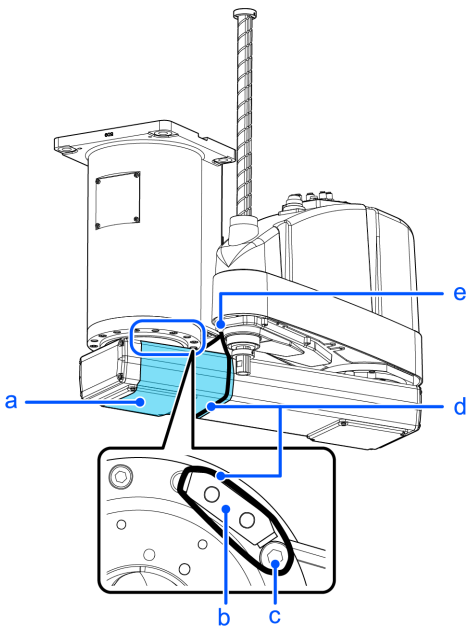

Symbol	Description
a	Sheet
b	Arm #1 stop bolt

Symbol	Description
c	Arm fixing bolt
d	Cable tie
e	Bolt: M4 × 15 Washer

3. While supporting the bottom of Arm #1 by hand so that the Manipulator does not fall over, remove the anchor bolts. Then, remove the Manipulator from the ceiling.

GX10-B/GX10-C65R**

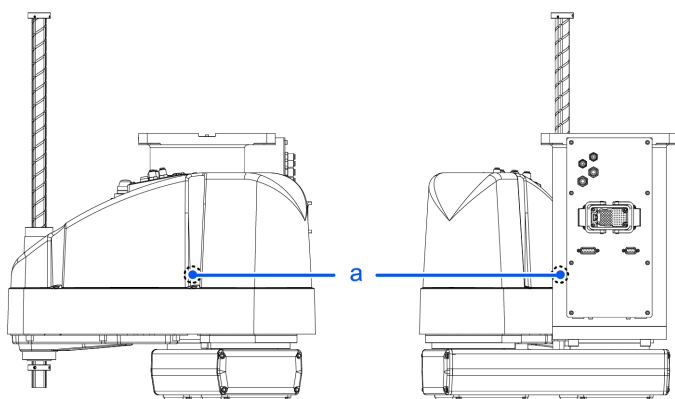

Symbol	Description
a	Center of gravity

GX10-B/GX10-C/GX20-B/GX20-C85R**

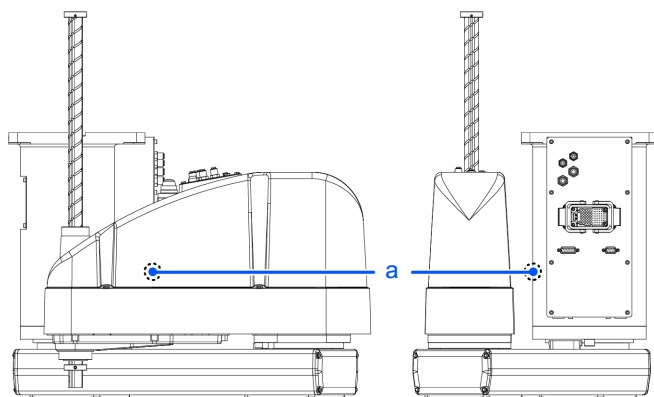

Symbol	Description
a	Center of gravity

GX20-B/GX20-CA0R**

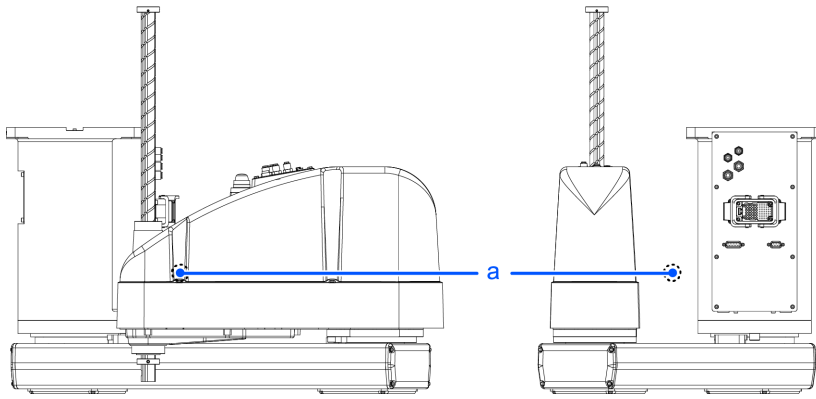

Symbol	Description
a	Center of gravity

4.4 Setting the Hand

4.4.1 Installing the Hand

The hand (end effector) must be prepared by the customer. When installing the hand, take note of the following. For details on attaching the hand, refer to the following manual.

"Hand Function Manual"

WARNING

- Before attaching a hand or peripheral equipment, be sure to always turn off the Controller and related equipment and unplug the power cables. Performing any work procedure with the power turned on is extremely dangerous and may result in electric shock and/or malfunction of the robot system.

CAUTION

When the hand is equipped with a workpiece gripping mechanism, ensure that the wiring and pneumatic tubes do not cause the hand to release the workpiece when the power is turned off. When the wiring and pneumatic tubes are not designed for the hand to maintain its grip on the workpiece when the power is turned off, pressing the emergency stop switch releases the workpiece, which may damage the robot system and the workpiece.

By default, all I/Os are designed to automatically turn off (0) when the power is shut off, when an emergency stop is triggered, or by the robot system's safety function.

However, I/Os set with the Hand function does not turn off (0) when executing the Reset statement, or when performing an emergency stop.

For the risk of the residual air pressure, conduct a risk assessment on the equipment and take the necessary protective measures.

Shaft

- Attach the hand to the lower end of the shaft.
For the layout dimensions in the area around the shaft and the overall dimensions of the Manipulator, refer to the following section.
[Names of Parts and Their Dimensions](#)
- Do not move the upper limit mechanical stop on the lower side of the shaft. When performing a Jump operation, the upper limit mechanical stop may come into contact with the Manipulator body, which may cause the Manipulator to stop functioning properly.
- When attaching the hand to the shaft, have the hand hold the shaft using M4 or larger screws.

Brake release switch

- Joint #3 and Joint #4 have an electromagnetic brake that is triggered when the power is off, preventing them from being moved up and down or rotated by hand.

To move Joint #3 up or down or rotate Joint #4 when attaching a hand, turn on the Controller, and then press the brake release switch.

This button switch is a momentary brake release type where the brake is released only while the button switch is being pressed. The switch releases the brake of Joints #3 and #4 simultaneously.

- When pressing the brake release switch, watch for the shaft descending or rotating under the weight of the hand.
 - *: The shaft may drop due to the weight of the hand or other object.

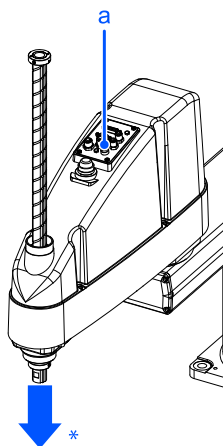

Symbol	Description
a	Brake release switch

Layout

- When attaching and operating a hand, the hand may come into contact with the Manipulator body due to the outer diameter of the hand, the size of the workpiece, or the position of the arm. Carefully consider the interference area of the hand when designing the system layout.

4.4.2 Attaching Cameras and Valves

The base and Arm #2 (bottom surfaces) have threaded holes as shown in the figure below. Use the threaded holes in Arm #2 (bottom surface) for attaching cameras, valves, and other heavy objects to the Manipulator.

Common for all models

(Units: mm)

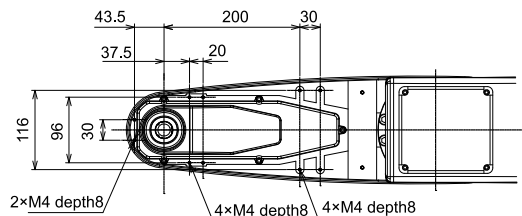
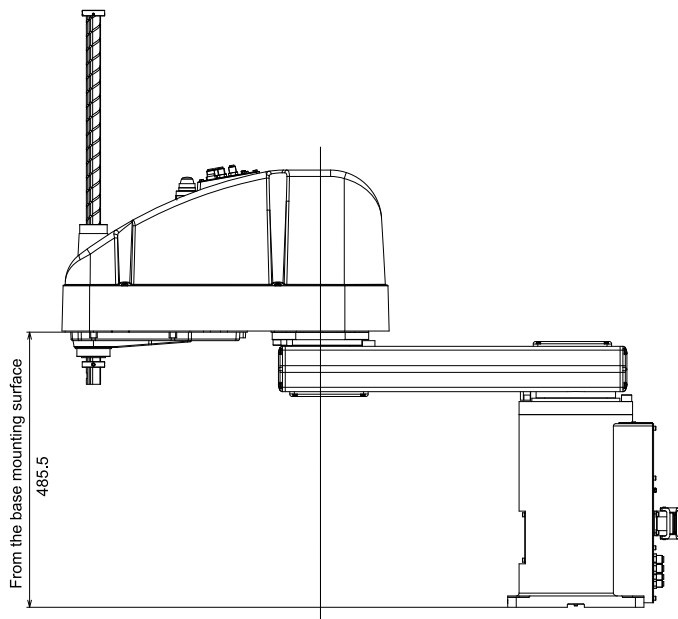

Table top mounting specifications

(Units: mm)



Wall mounting specifications

(Units: mm)

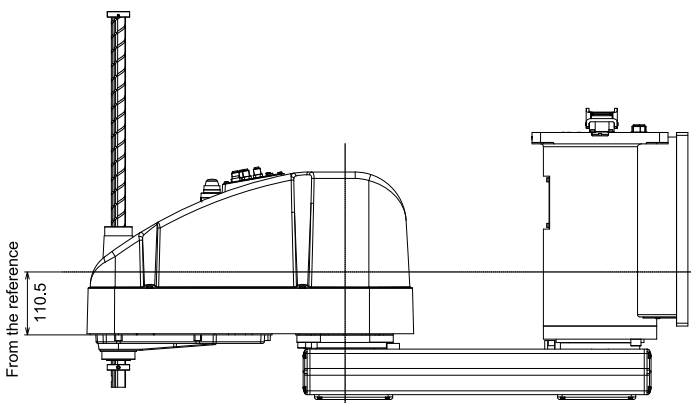

Ceiling mounting specifications (Units: mm)

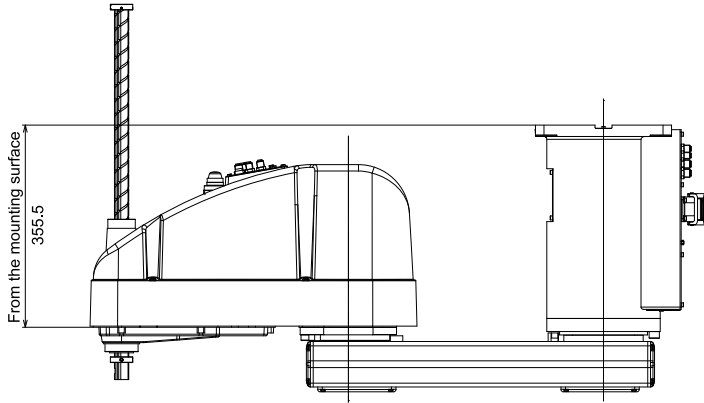

4.4.3 Weight and Inertia Settings

To ensure that the Manipulator is functioning properly, keep the load (the sum of the weights of the hand and workpiece) and the moment of inertia of the load within the rated values, and do not allow for eccentricity from the center of the Joint #4. If, for some unavoidable reason, the load or moment of inertia exceeds the rated value, or if eccentricity occurs, configure parameters as described in the "Weight setting" and "Inertia setting."

These settings optimize the Manipulator's PTP motion, reduce vibration, and shorten operation times. This also works to curb any persistent vibration that may occur when the hand and workpiece have a large moment of inertia.

You can also perform settings using the "Weight, Inertia, and Eccentricity/Offset Measurement Utility".

For details, refer to the following manual:

"Epson RC+ User's Guide - Weight, Inertia, and Eccentricity/Offset Measurement Utility"

4.4.3.1 Weight Setting

⚠ CAUTION

- **GX10-B/GX10-C Series**
The total weight of the hand and the workpiece must not exceed 10 kg. The GX10-B/GX10-C Manipulators are not designed to work with loads exceeding 10 kg.
- **GX20-B/GX20-C Series**
The total weight of the hand and the workpiece must not exceed 20 kg. The GX20-B/GX20-C series Manipulators are not designed to work with loads exceeding 20 kg. Always set the value according to the load. Setting the hand weight parameter to a value smaller than the actual weight may cause errors or impact that not only impair full functionality but also shorten the life of the mechanical components.

For the GX10-B/GX10-C/GX20-B/GX20-C series, the allowable load (hand weight and workpiece weight) is as shown below.

	Rated	Max.
GX10-B/GX10-C series	5 kg	10 kg
GX20-B/GX20-C series	10 kg	20 kg

Depending on the load weight, change the setting for the hand weight parameter in the Weight statement. After the setting is changed, the maximum speed and acceleration/deceleration of the Manipulator during PTP motion that correspond to the "Hand Weight" are corrected automatically.

4.4.3.1.1 Weight of Load Attached to Shaft

The weight of the load (hand + workpiece) attached to the shaft can be set by the "Hand Weight" parameter in the Weight statement.

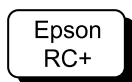

Go to [Tools] - [Robot Manager] - [Weight] panel, and enter the value in the [Weight] text box. (This can also be set using the Weight statement in [Command Window].)

4.4.3.1.2 Weight of Load Attached to Arm

When a camera, valve, or other object is attached to the arm, its weight is converted to the equivalent weight of the shaft and added to the weight of the load attached to shaft to set the "Hand Weight" parameter.

If an external wiring unit (excluding cables) is installed near the user connector on the Arm #2 side, add 0.16 kg to the equivalent weight conversion value of the shaft.

Equivalent weight formula

$$W_M = M \times (L_M + L_1)^2 / (L_1 + L_2)^2$$

W_M : Equivalent weight

M : Weight of load attached to the arm

L_1 : Length of Arm #1

L_2 : Length of Arm #2

L_M : Distance from rotation center of Joint #2 to center of gravity of load attached to the arm

Example:

Calculates [Weight] parameter when a 1 kg camera is attached to the end of GX10-B Arm #2 (500 mm from the center of rotation of Joint #2) with a load weight of $W = 2$ kg

$$W = 2$$

$$M = 1$$

$$L_1 = 450$$

$$L_2 = 400$$

$$L_M = 500$$

$$W_M = 1 \times (500 + 450)^2 / (400 + 450)^2 = 1.25 \text{ (Round up to two decimal places)}$$

$$W + W_M = 2 + 1.25 = 3.25$$

Enter "3.25" for the [Hand Weight] parameter.

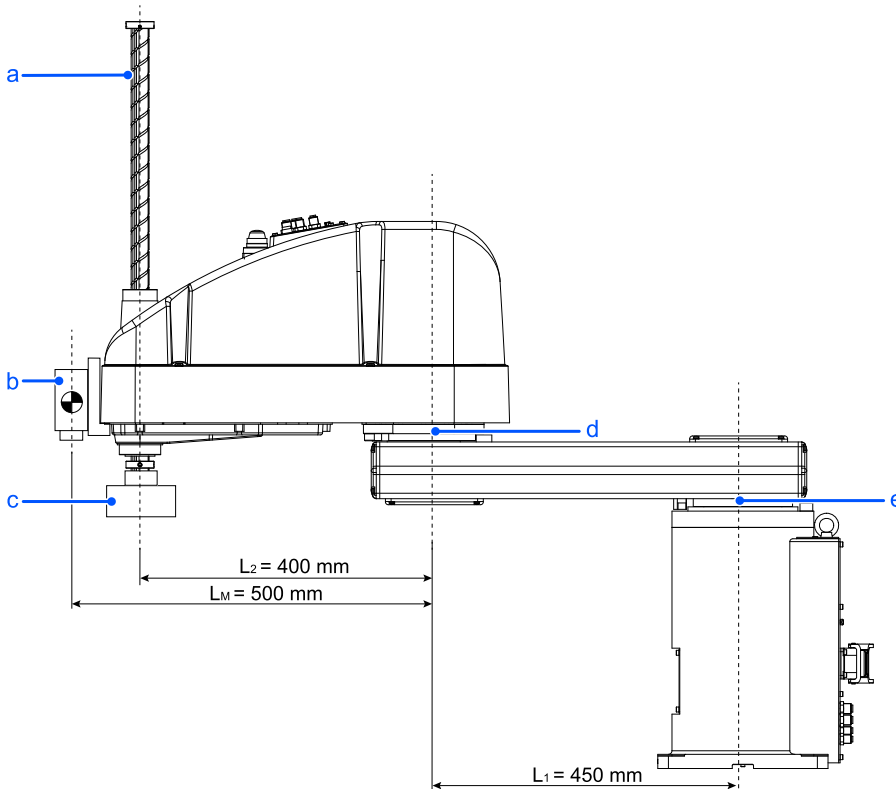

Symbol	Description
a	Shaft
b	Weight of the entire camera $M = 1$ kg

Symbol	Description
c	W = 2 kg
d	Joint #2
e	Joint #1

4.4.3.1.3 Automatic Speed Correction at Weight Setting

GX10-B/GX10-C Series

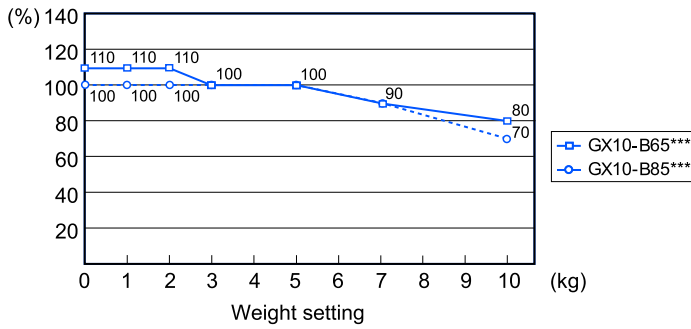

The percentages on the graph are ratios based on 100% as the speed at the rated (5 kg) setting.

GX20-B/GX20-C Series

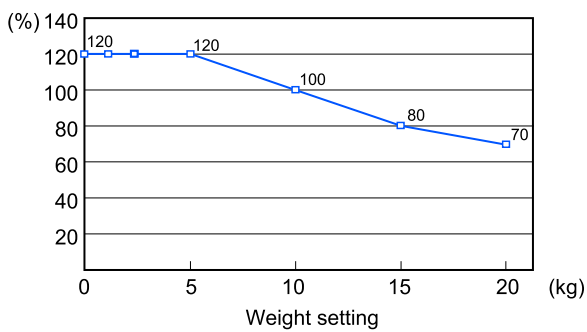

The percentages on the graph are ratios based on 100% as the speed at the rated (10 kg) setting.

4.4.3.1.4 Automatic Acceleration/Deceleration Correction at Weight Setting

GX10-B/GX10-C Series

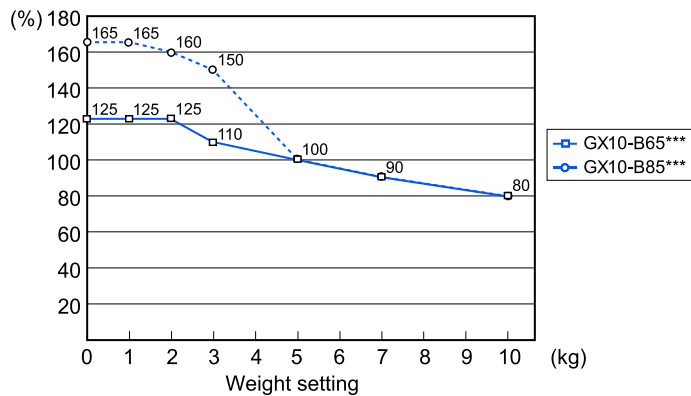

The percentages on the graph are ratios based on 100% as the acceleration/deceleration at the rated (5 kg) setting.

GX20-B/GX20-C Series

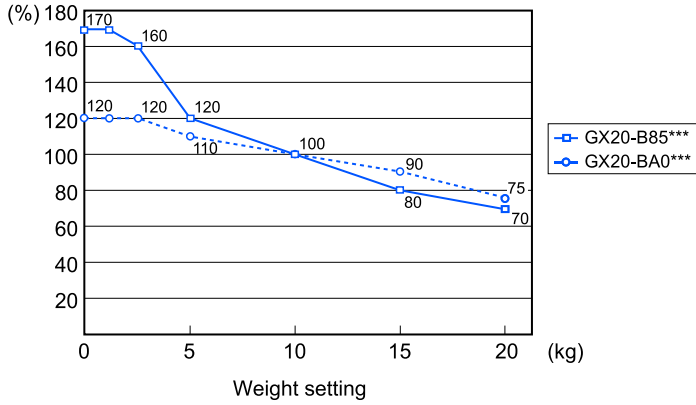

The percentages on the graph are ratios based on 100% as the acceleration/deceleration at the rated (10 kg) setting.

4.4.3.2 Inertia Setting

4.4.3.2.1 Moment of Inertia and Inertia Setting

The moment of inertia is a quantity that expresses how hard it is for an object to turn, and it is expressed in terms of values for the moment of inertia, inertia, or GD^2 . When a hand or other object is attached to a shaft for operation, the moment of inertia of the load must be taken into consideration.

⚠ CAUTION

- **GX10-B/GX10-C Series**
The moment of inertia of the load (weight of the hand and workpiece) must be $0.25 \text{ kg}\cdot\text{m}^2$ or less. The GX10-B/GX10-C series Manipulators are not designed to work with a moment of inertia exceeding $0.25 \text{ kg}\cdot\text{m}^2$.
- **GX20-B/GX20-C Series**
The moment of inertia of the load (weight of the hand and workpiece) must be $0.45 \text{ kg}\cdot\text{m}^2$ or less. The GX20-B/GX20-C series Manipulators are not designed to work with a moment of inertia exceeding $0.45 \text{ kg}\cdot\text{m}^2$. Always set the value corresponding to the moment of inertia. Setting a parameter value that is smaller than the actual moment of inertia may cause errors or impact, may prevent the Manipulator from working at full functionality, and may shorten the lifespan of mechanical parts.

The allowable moment of inertia of a load for a GX10-B/GX10-C/GX20-B/GX20-C series Manipulator is as follows.

	Rated	Max.
GX10-B/GX10-C series	$0.02 \text{ kg}\cdot\text{m}^2$	$0.25 \text{ kg}\cdot\text{m}^2$
GX20-B/GX20-C series	$0.05 \text{ kg}\cdot\text{m}^2$	$0.45 \text{ kg}\cdot\text{m}^2$

Depending on the moment of inertia, change the setting of the moment of inertia parameter for the load in the Inertia statement. After the setting is changed, the maximum acceleration/deceleration of Joint #4 during PTP motion that corresponds to the "Inertia" value is corrected automatically.

4.4.3.2.2 Moment of Inertia of Load Attached to Shaft

The moment of inertia of the load (hand + workpiece) attached to the shaft can be set by the "Inertia" parameter in the Inertia statement.

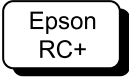

Go to [Tools] - [Robot Manager] - [Inertia] panel, and enter the value in [Inertia].
 This can also be set using the Inertia statement in [Command Window].

4.4.3.2.3 Automatic Acceleration/Deceleration Correction of Joint #4 at Inertia (Moment of Inertia) Setting

GX10-B/GX10-C Series

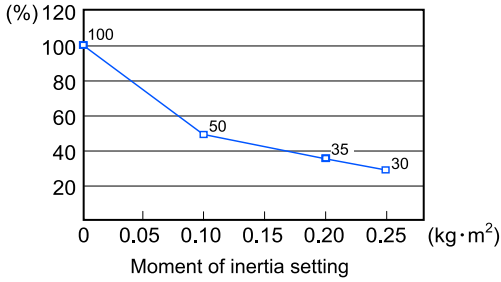

The percentages on the graph are ratios based on 100% as the acceleration/deceleration at the rated (0 kg·m²) setting.

GX20-B/GX20-C Series

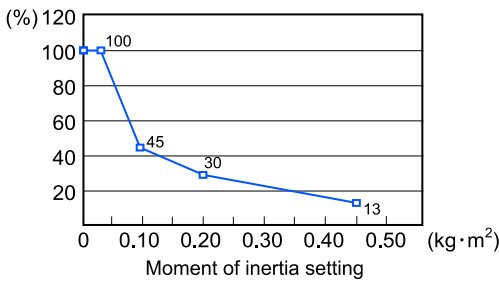

The percentages on the graph are ratios based on 100% as the acceleration/deceleration at the rated (0.05 kg·m²) setting.

4.4.3.2.4 Eccentricity and Inertia Setting

⚠ CAUTION

- The eccentricity of the load (hand and workpiece) must be 200 mm or less. GX10-B/GX10-C series and GX20-B/GX20-C series Manipulators are not designed to work with eccentricities exceeding 200 mm. Always set the value based on the eccentricity. Setting the eccentricity parameter to a value smaller than the actual eccentricity may cause errors or impact that not only impair full functionality but also shorten the life of the mechanical components.

The allowable load eccentricity for GX10-B/GX10-C series and GX20-B/GX20-C series Manipulators is 0 mm at the default rating and 200 mm at the maximum. Depending on the load eccentricity, change the setting for the eccentricity parameter in Inertia statement. After the setting is changed, the maximum acceleration/deceleration of the Manipulator during PTP motion that corresponds to the "Eccentricity" is corrected automatically.

Eccentricity

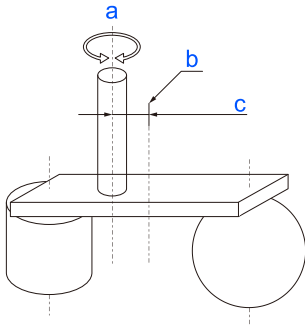

Symbol	Description
a	Rotation axis
b	Load center of gravity position
c	Eccentricity (200 mm or less)

4.4.3.2.5 Eccentricity of Load Attached to Shaft

The eccentricity of the load (hand + workpiece) attached to the shaft can be set by the "Eccentricity" parameter in the Inertia statement.



Go to [Tools] - [Robot Manager] - [Inertia] panel, and enter the value in [Eccentricity]. This can also be set using the Inertia statement in [Command Window].

4.4.3.2.6 Automatic Acceleration/Deceleration Correction at Inertia (Eccentricity) Setting

GX10-B/GX20-B series

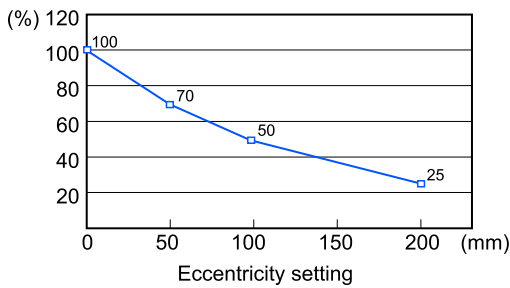

The percentages on the graph are ratios based on 100% as the acceleration/deceleration at the 0 mm setting.

4.4.3.2.7 Calculating the Moment of Inertia

An example of calculating the moment of inertia of a load (hand holding a workpiece) is shown below.

The moment of inertia of the entire load is calculated by the sum of (A), (B), and (C).

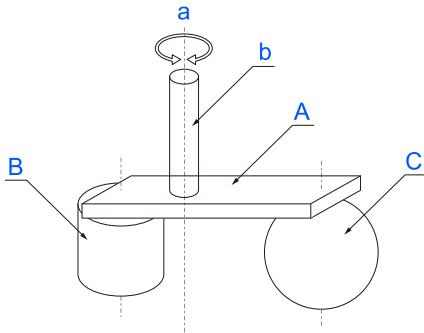

$$\text{Whole moment of inertia} = \text{Moment of inertia of end effector (A)} + \text{Moment of inertia of work piece (B)} + \text{Moment of inertia of work piece (C)}$$

Symbol	Description
a	Rotation axis
b	Shaft
A	Hand
B	Workpiece
C	Workpiece

The methods for calculating the moment of inertia for (A), (B), and (C) are shown below. Use the moment of inertia of these basic shapes as a reference to find the moment of inertia of the entire load.

(A) Moment of inertia of a rectangular parallelepiped

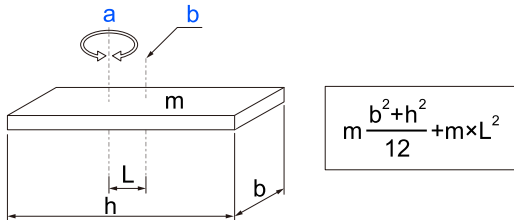

Symbol	Description
a	Rotation axis
b	Center of gravity of rectangular parallelepiped

(B) Moment of inertia of a cylinder

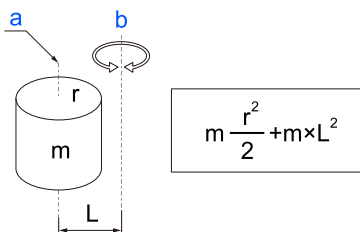

Symbol	Description
a	Center of gravity of cylinder
b	Rotation axis

(C) Moment of inertia of a sphere

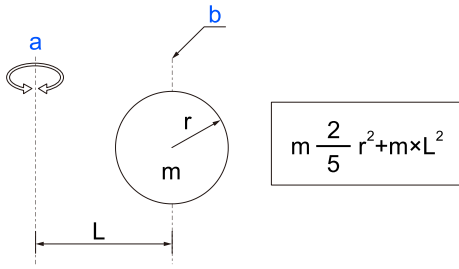

Symbol	Description
a	Rotation axis
b	Center of gravity of sphere

4.4.4 Safety Information for Auto Acceleration of Joint #3

When performing horizontal movement in PTP motion, the operation time can be shorted by setting the shaft to a high position.

When performing horizontal movement in PTP motion, if the shaft height is less than a certain value, the auto acceleration function is activated, and the acceleration/deceleration of the movement is set slower for lower shaft heights. A higher shaft position results in a faster acceleration/deceleration for the movement, but the up movement time and down movement time of the shaft are also required. Adjust the shaft height by taking into consideration the positional relationship between the current position and the target position.

The shaft height at the time of horizontal movement for the Jump statement can be set by the LimZ statement.

4.4.4.1 Automatic Acceleration/Deceleration Correction by Shaft Position

GX10-B/GX10-C/GX20-B/GX20-C Series

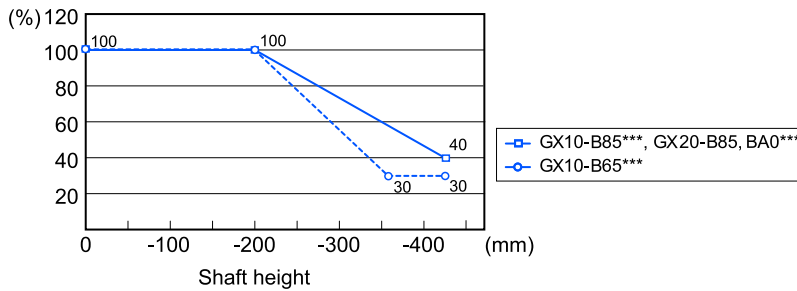

The percentages on the graph are ratios based on 100% as the acceleration/deceleration at the shaft upper limit position.

KEY POINTS

Horizontal movement with the shaft lowered may cause overshooting during positioning.

4.5 Work Envelope

⚠ WARNING

- Do not operate the Manipulator with the mechanical stop removed. Removing the mechanical stop is extremely dangerous because the Manipulator may move to a position outside its normal work envelope.

⚠ CAUTION

- When restricting the work envelope for safety reasons, be sure to make settings using both the pulse range and mechanical stop.

The work envelope is preset at the factory as explained in the following section.

Standard Work Envelope

The work envelope can be set by one of the following three methods.

- Setting by pulse range (for all joints)
- Setting by mechanical stops (for Joints #1 to #3)
- Setting the rectangular range in the XY coordinate system of the Manipulator (for Joints #1 and #2)

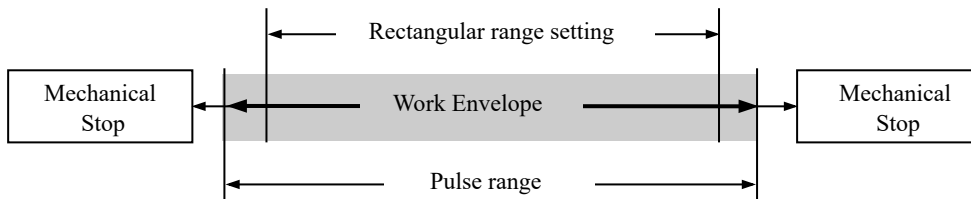

To limit the work envelope for layout efficiency or safety reasons, make the settings as explained in the following sections.

Work Envelope Setting by Pulse Range

Setting the Work Envelope by Mechanical Stops

Setting the Rectangular Range in the XY Coordinate System of the Manipulator

4.5.1 Work Envelope Setting by Pulse Range

Pulses are the basic unit of Manipulator motion. The motion range (work envelope) of the Manipulator is set by the pulse lower limit value and pulse upper limit value (pulse range) for each joint.

Pulse values are read from the encoder output of the servomotor.

For the maximum pulse range, refer to the following sections.

The pulse range must be set within the mechanical stop range.

Joint #1 Maximum Pulse Range

Joint #2 Maximum Pulse Range

Joint #3 Maximum Pulse Range

Joint #4 Maximum Pulse Range

✎ KEY POINTS

Once the Manipulator receives an operation command, it checks whether the target position specified by the command is within the pulse range before operating. If the target position is outside of the pulse range that was set, an error occurs and the Manipulator does not move.

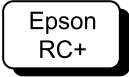

Go to [Tools] - [Robot Manager] - [Range] panel, and make the setting.
 This can also be set using the Range statement in [Command Window].

4.5.1.1 Joint #1 Maximum Pulse Range

The 0 (zero) pulse position of Joint #1 is the position where Arm #1 is facing the positive (+) direction on the X-coordinate axis.

With the 0 pulse as a starting point, the counterclockwise pulse value is defined as positive (+), and the clockwise pulse value is defined as negative (-).

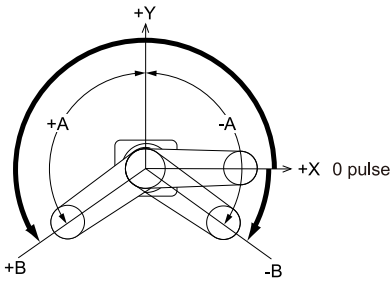

	Arm Length (mm)	Mounting Specifications		
		Table Top	Ceiling	Wall
A: Max. Motion range (deg.)	650	±152	±107	±107
	850, 1000		±152	
B: Max. pulse range (pulse)	650	-1805881 to +7048761	-495161 to 5738041	-495161 to 5738041
	850, 1000		-1805881 to +7048761	

4.5.1.2 Joint #2 Maximum Pulse Range

The 0 (zero) pulse position of Joint #2 is the position where Arm #2 is aligned with Arm #1. (The orientation of Arm #1 does not matter.)

With the 0 pulse as a starting point, the counterclockwise pulse value is defined as positive (+), and the clockwise pulse value is defined as negative (-).

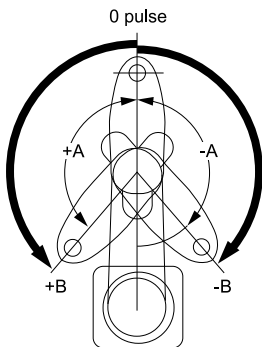

	Type		Mounting Specifications	
			Table Top	Ceiling, Wall
A: Max. motion range (deg.)	GX10-B/GX10-C65***		±152.5	±130
	GX10-B/GX10-C/GX20-B/GX20-C85*S*			±152.5
	GX10-B/GX10-C/GX20-B/GX20-C85*C*, P*	Z: 0 to -360	±152.5	±151
		Z: -360 to -390	±151	
	GX20-B/GX20-CA0***		±152.5	±152.5
B: Max. pulse range (pulse)	GX10-B/GX10-C65***		±2776178	±2366578
	GX10-B/GX10-C/GX20-B/GX20-C85*S*			±2776178
	GX10-B/GX10-C/GX20-B/GX20-C85*C*, P*	Z: 0 to -360	±2776178	±2748872
		Z: -360 to -390	±2748872	
	GX20-B/GX20-CA0***		±2776178	±2776178

KEY POINTS

Z: In the -360 to -390 mm range, the area is limited due to interference between the Manipulator body and the arm.

4.5.1.3 Joint #3 Maximum Pulse Range

The 0 (zero) pulse position of Joint #3 is the position where the shaft is at its upper limit. The pulse value is always negative because Joint #3 moves down from the 0 pulse position.

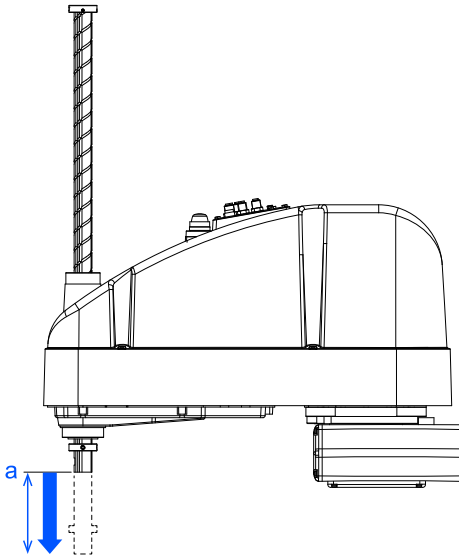

Symbol	Description
a	Upper limit: 0 pulse

Type	Joint #3 Stroke	Lower Limit Pulse
GX10-B/GX10-C/GX20-B/GX20-C**1S*	180 mm	-973210
GX10-B/GX10-C/GX20-B/GX20-C**4S*	420 mm	-2270823
GX10-B/GX10-C/GX20-B/GX20-C**1C*, P*	150 mm	-811008
GX10-B/GX10-C/GX20-B/GX20-C**4C*, P*	390 mm	-2108621

KEY POINTS

For Manipulator models with standard specifications (GX20-B/GX20-C***S*), cleanroom & ESD specifications (GX10-B/GX10-C/GX20-B/GX20-C***C*) and protected-models (GX10-B/GX10-C/GX20-B/GX20-C***P*), the work envelope set by the Joint #3 mechanical stop cannot be changed.

4.5.1.4 Joint #4 Maximum Pulse Range

The 0 (zero) pulse position of Joint #4 is the position where the flat surface near the end of the shaft faces toward the end of Arm #2. (The orientation of Arm #2 does not matter.)

With the 0 pulse as a starting point, the counterclockwise pulse value is defined as positive (+), and the clockwise pulse value is defined as negative (-).

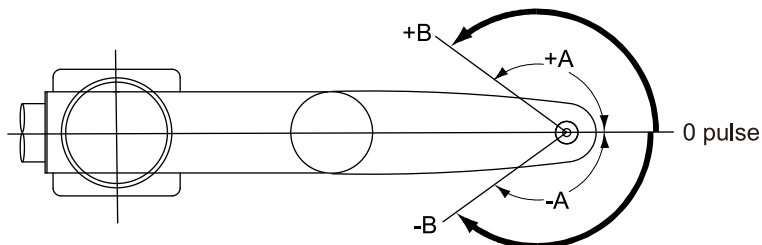

	GX10-B/GX10-C*****	GX20-B/GX20-C*****
A: Max. motion range (deg.)	±360	
B: Max. pulse range (pulse)	±1951517	±2752512

4.5.2 Setting the Work Envelope by Mechanical Stops

Mechanical stops set the absolute work envelope that physically limits where the Manipulator can move. Both Joints #1 and #2 have threaded holes in positions corresponding to angles for the setting area. The positions of the mechanical stops (variable) set the work envelope. Install the bolts in the threaded holes corresponding to the angles to be set. Joint #3 can be set to any length less than the maximum stroke.

Table top mounting specifications

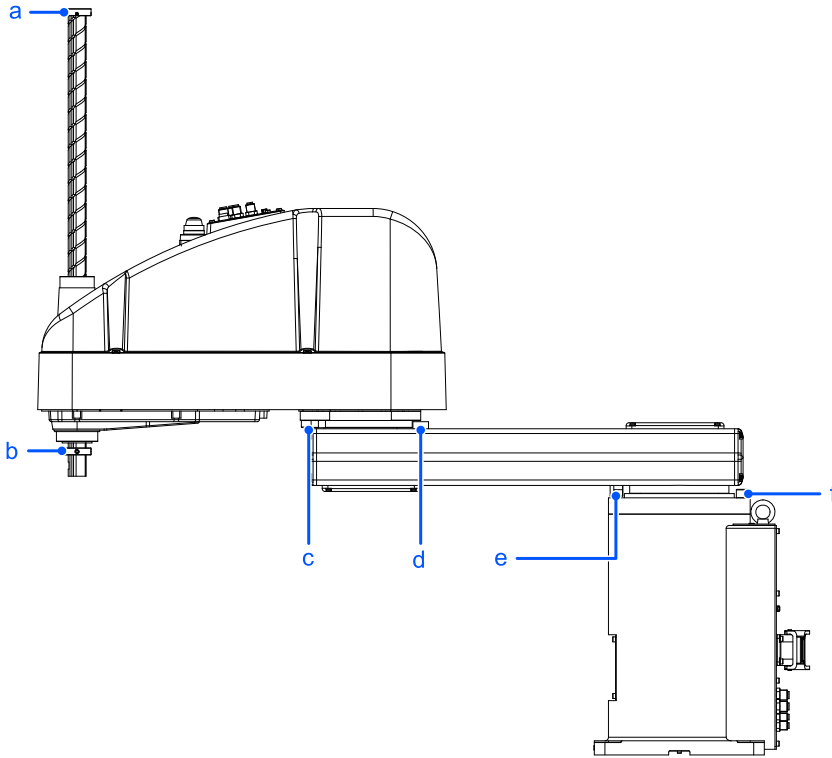

Symbol	Description
a	Joint #3 mechanical stop (lower limit mechanical stop)
b	Joint #3 mechanical stop (upper limit mechanical stop) *Do not move the position.
c	Joint #2 mechanical stop (variable)
d	Joint #2 mechanical stop (fixed)
e	Joint #1 mechanical stop (fixed)
f	Joint #1 mechanical stop (variable)

Wall Mounting Specifications

Only the stop positions that are different from the model with table top mounting specifications are explained here.

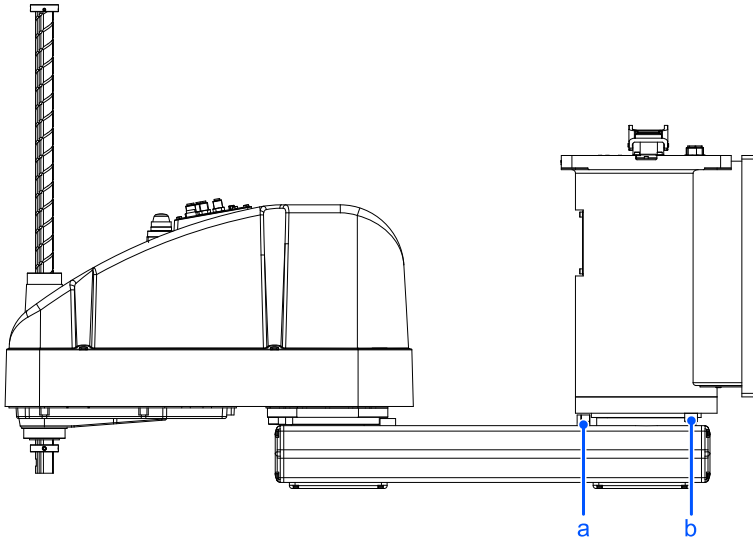

Symbol	Description
a	Joint #1 mechanical stop (fixed)
b	Joint #1 mechanical stop (variable)

Ceiling mounting specifications

Only the stop positions that are different from the model with table top mounting specifications are explained here.

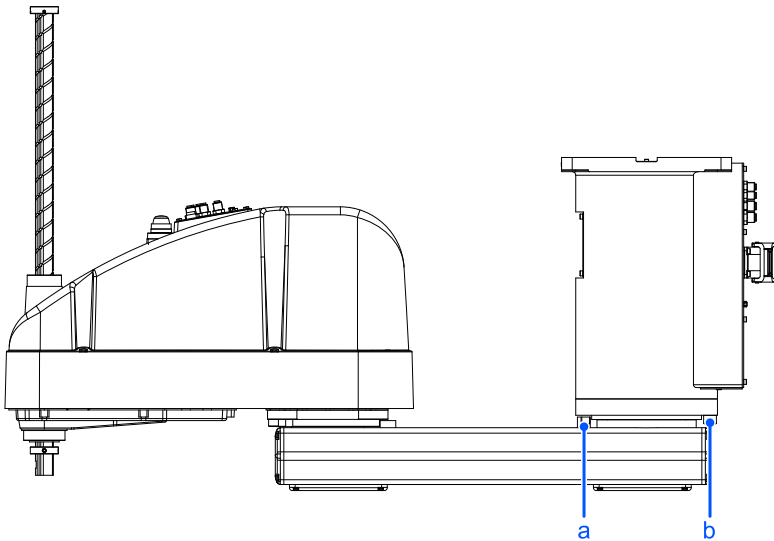

Symbol	Description
a	Joint #1 mechanical stop (fixed)
b	Joint #1 mechanical stop (variable)

4.5.2.1 Setting the Mechanical Stops of Joints #1 and #2

Both Joints #1 and #2 have threaded holes in positions corresponding to angles for the setting area. The positions of the mechanical stops (variable) set the work envelope.

Use the following procedure to install the bolts in the holes corresponding to the angle that you want to set.

1. Turn off the Controller.

2. Install a hexagon socket head cap bolt into the threaded hole corresponding to the setting angle, and tighten it.

Joint #	Hexagon Socket Head Cap Bolt	Number of Bolts	Recommended Tightening Torque	Strength
1	M12 × 20 full thread	1	127.4 N·m (1300 kgf·cm)	ISO898-1 property class 10.9 or 12.9 equivalent
2	M10 × 10 full thread	2	73.5 N·m (750 kgf·cm)	

3. Turn on the Controller.

4. Set the pulse range corresponding to the new positions of the mechanical stops.

 **KEY POINTS**

Be sure to set the pulse range inside the positions of the mechanical stop range.

Example: Setting Joint #1 to -105° to +105° and Joint #2 to -122.5° to +122.5° for the GX10-B854S

Epson
RC+

Execute the following command in [Command Window].

```
>JRANGE 1,-436907,5679787 'Sets the pulse range of Joint #1
>JRANGE 2,-2230045,2230045 'Sets the pulse range of Joint #2
>RANGE 'Confirms the setting value using the Range statement
-436907,5679787,-2230045,2230045,-2270823,0,-1951517,1951517
```

5. Move the arm by hand until it touches the mechanical stops to check that nothing will hinder the arm motion during operation, such as by hitting peripheral equipment.

6. Operate the joint with the new settings at low speeds until it reaches the positions of the minimum and maximum values of the pulse range. Check that the arm does not hit any mechanical stops.

(Check the position of the mechanical stops and the motion range that were set.)

Example: Setting Joint #1 to -105° to +105° and Joint #2 to -122.5° to +122.5° for the GX10-B854S

Epson
RC+

Execute the following command in [Command Window].

```
>MOTOR ON 'Turns on the motor
>POWER LOW 'Sets to low power mode
>SPEED 5 'Sets to low speed
>PULSE -436907,0,0,0 'Moves to the minimum pulse position of Joint #1
>PULSE 5679787,0,0,0 'Moves to the maximum pulse position of Joint #1
>PULSE 2621440,-2230045,0,0 'Moves to the minimum pulse position of Joint #2
>PULSE 2621440,2230045,0,0 'Moves to the maximum pulse position of Joint #2
```

The Pulse statement (Go Pulse statement) moves all joints to the specified positions at the same time. Set safe positions after taking into consideration the motion of the joints whose pulse range have been changed and also the other joints. In this example, when checking Joint #2, Joint #1 is moved to the 0° position (pulse value: 2621440) near the center of its work envelope.

If the arm hits a mechanical stop or if an error occurs after the arm hits a mechanical stop, either reset the pulse range to a narrower pulse range so that nothing blocks the arm motion, or extend the positions of the mechanical stops within the limit.

Joint #1 mechanical stop

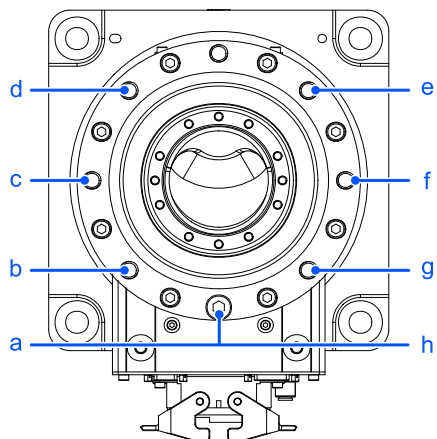

Max. motion range (deg.):

Mounting Specifications	Arm Length (mm)	a	b	c	d	e	f	g	h
Table top	650, 850, 1000	+152	+107	+60	+15	-15	-60	-107	-152
Ceiling	650	-							-
	850, 1000	+152							-152
Wall	650, 850, 1000	-	-						

Max. pulse range (pulse):

Mounting Specifications	Arm Length (mm)	a	b	c	d	e	f	g	h
Table top	650,850, 1000	+7048761	+5738041	+4369067	+3058347	+2184534	+873814	-495161	-1805881
Ceiling	650	-							-
	850, 1000	+7048761							-1805881
Wall	650, 850, 1000	-	-						

Joint #2 mechanical stop

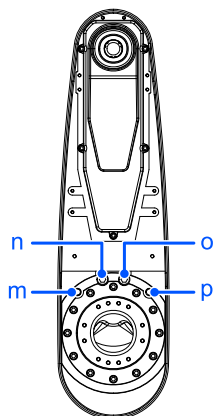

Max. motion range (deg.):

Arm Length (mm)	Mounting Specifications	Environmental Specifications	Z-value Range (mm)	m	n	o	q
650	Table top	S,C,P	-	+122.5	+152.5	-152.5	-122.5
	Ceiling, Wall	S,C,P	-	+100	+130	-130	-100
850	Table top	S	-	+122.5	+152.5	-152.5	-122.5
		C,P	Z: 0 to -360				
	Ceiling, Wall		S	-	+122.5	+152.5	-152.5
		C,P	-	+100	+130	-130	-100
1000	Table, Ceiling, Wall	S,C,P	-	+122.5	+152.5	-152.5	-122.5

Max. pulse range (pulse):

Arm Length (mm)	Mounting Specifications	Environmental Specifications	Z-value Range (mm)	m	n	o	q
650	Table top	S,C,P	-	+2230045	+2776178	-2776178	-2230045
	Ceiling, Wall	S,C,P	-	+1820445	+2366578	-2366578	-1820445
850	Table top	S	-	+2230045	+2776178	-2776178	-2230045
		C,P	Z: 0 to -360				
	Ceiling, Wall		S	-	+2230045	+2776178	-2776178
		C,P	-	+1820445	+2366578	-2366578	-1820445
1000	Table, Ceiling, Wall	S,C,P	-	+2230045	+2776178	-2776178	-2230045

KEY POINTS

Z: In the -360 to -390 mm range, the area is limited due to interference between the Manipulator body and the arm.

4.5.2.2 Setting the Mechanical Stop of Joint #3

KEY POINTS

This method can be used only for the Manipulator models with standard specifications (GX10-B/GX10-C***S*). For Manipulator models with standard specifications (GX20-B/GX20-C***S*), cleanroom specifications (GX10-B/GX10-C/GX20-B/GX20-C***C*), and protected-models (GX10-B/GX10-C/GX20-B/GX20-C***P*), the work envelope set by the Joint #3 mechanical stop cannot be changed.

To change from the factory default position

1. Turn on the Controller, and turn off the motors using the Motor OFF statement.
2. Push up the shaft while pressing the brake release switch.
Do not push the shaft up to its upper limit or it will be difficult for the arm top cover to be removed. Push the shaft up to a position where the Joint #3 mechanical stop can be changed.

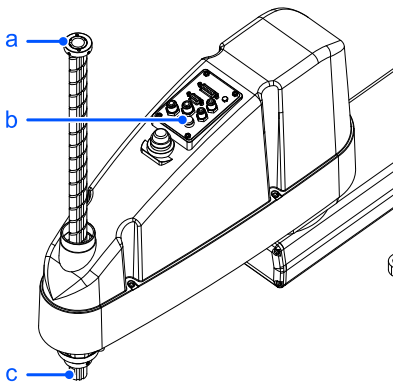

Symbol	Description
a	Lower limit mechanical stop
b	Brake release switch
c	Shaft

KEY POINTS

When you press the brake release switch, the shaft may lower or rotate due to the weight of the hand. Be sure to hold the shaft by hand while pressing the switch.

3. Turn off the Controller.
4. Loosen the lower limit mechanical stop screws (2 × M4 × 8, 2 × M6 × 6).
When changing the lower limit mechanical stop from the factory default position, use only the M6 set screws. Remove the M4 set screws from the lower limit mechanical stop and do not lose them. They are used again when returning

to the factory default position.

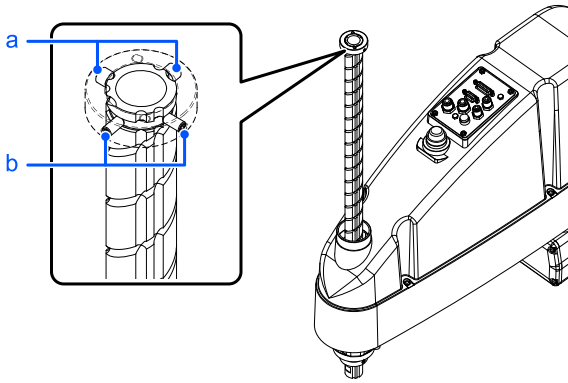

Symbol	Description
a	M6 × 6 set screw (recessed end)
b	M4 × 8 set screw (flat tip)

KEY POINTS

A mechanical stop is mounted on both the top and bottom of Joint #3. However, only the position of the lower limit mechanical stop on the top can be changed. Do not remove the upper limit mechanical stop on the bottom because the origin position of Joint #3 is determined by this stop.

- The upper end of the shaft defines the maximum stroke position. Move the lower limit mechanical stop down by the length that you want to limit the stroke.
 For example, when the lower limit mechanical stop is set at the "420 mm" stroke, the lower limit Z coordinate value is "-420". To change this value to "-320", move the lower limit mechanical stop down by "100 mm". Use calipers or similar tool to measure the distance when adjusting the mechanical stop.

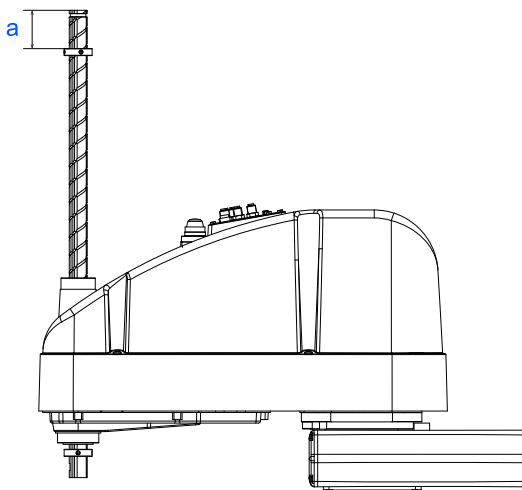

Symbol	Description
a	Measurement length

- Tighten the set screws (2 × M6 × 6) of the lower limit mechanical stop firmly at the positions shown in the figure below (one in the helical groove and one on the cylindrical surface).

Recommended tightening torque: $8.0 \pm 0.4 \text{ N}\cdot\text{m}$ ($82 \pm 4 \text{ kgf}\cdot\text{cm}$)

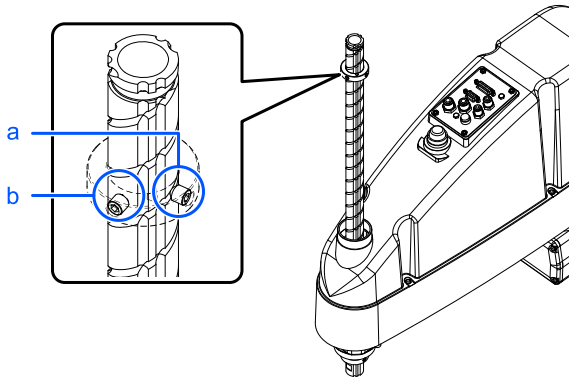

Symbol	Description
a	Helical groove
b	Cylindrical surface

7. Turn on the Controller.
8. Press down Joint #3 while pressing the brake release switch, and then check the lower limit position. Do not lower the mechanical stop too far. Otherwise, the joint may not reach a target position.
9. Calculate the lower limit pulse value of the pulse range using the formula shown below, and set the value.
The result of the calculation is always negative because the lower limit Z coordinate value is negative.

GX10-B/GX10-C1S (Z: -180 mm): Lower limit of pulse = (Lower limit Z coordinate value)/50 × 131072 × (66/32)**

GX10-B/GX10-C4S (Z: -420 mm): Lower limit of pulse = (Lower limit Z coordinate value)/50 × 131072 × (66/32)**

Example: To lower the mechanical stop by 80 mm and change the lower limit Z coordinate value to "-100" with a 180 mm stroke

$$(-100)/50 \times 131072 \times (66/32) = -540672$$

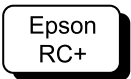

Execute the following command in [Command Window].

```
>J RANGE 3, -540672, 0           'Sets the pulse range of Joint #3
```

10. Using the Pulse statement (Go Pulse statement), move Joint #3 to the lower limit position of the pulse range that was set at low speed.

If the mechanical stop range is less than the pulse range, Joint #3 will hit the mechanical stop and an error will occur. When an error occurs, either change the pulse range to a narrower setting or extend the position of the mechanical stop within the limit.

Example: To lower the mechanical stop by 80 mm and change the lower limit Z coordinate value to "-100" with a 180 mm stroke

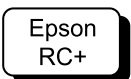

Execute the following command in [Command Window].

```
>MOTOR ON           ' Turns on the motor
>SPEED 5            ' Sets to low speed
>PULSE 0,0,- 540672,0 ' Moves to the lower limit pulse position of Joint
#3
```

(In this example, all pulses except those for Joint #3 are "0". Substitute these "0" values with the other pulse values to specify a position where interference will not occur even when lowering Joint #3.)

To return to the factory default position

1. Turn on the Controller, and turn off the motors using the Motor OFF statement.
2. Push up the shaft while pressing the brake release switch.
Do not push the shaft up to its upper limit or it will be difficult for the arm top cover to be removed. Push the shaft up to a position where the Joint #3 mechanical stop can be changed.

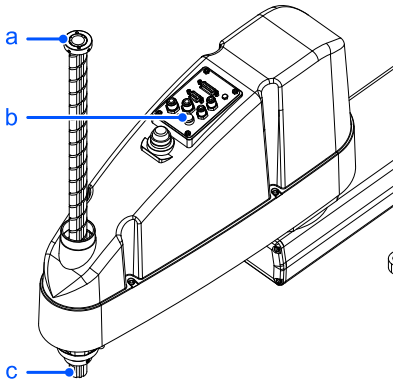

Symbol	Description
a	Lower limit mechanical stop
b	Brake release switch
c	Shaft

KEY POINTS

When you press the brake release switch, the shaft may lower or rotate due to the weight of the hand. Be sure to hold the shaft by hand while pressing the switch.

3. Turn off the Controller.
4. Loosen the lower limit mechanical stop screws ($2 \times M6 \times 6$).

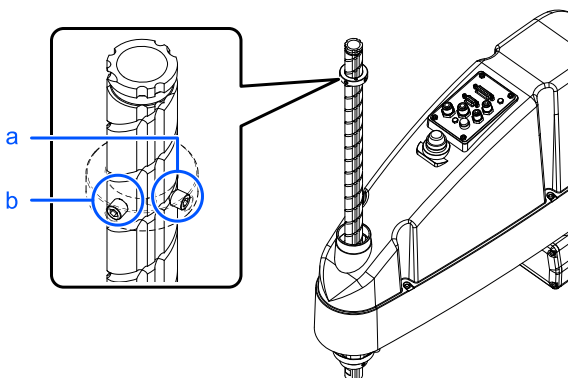

Symbol	Description
a	M6 × 6 set screw
b	

5. Prepare the 2 × M4 × 8 set screws removed in step 4 of "To change from the factory default position."
 Adjust so that the shaft groove and set screws (2 × M4 × 8) are in the positions shown below, and insert the set screws (2 × M4 × 8).
 Adjust so that the upper end face of the shaft is aligned with the upper end face of the mechanical stop. Securely tighten the set screws (2 × M4 × 8).

Recommended tightening torque: 2.4 ± 0.1 N·m(24 ± 1 kgf·cm)

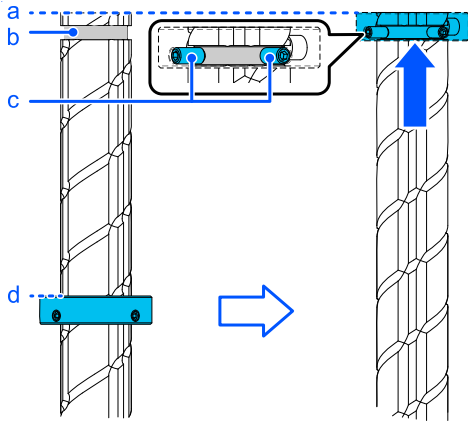

Symbol	Description
a	Upper end of shaft
b	Groove on shaft
c	Set screw
d	Upper end of mechanical stop

6. Insert the set screws (2 × M6 × 6) of the lower limit mechanical stop from the outer surface of the lower limit mechanical stop.
7. Turn on the Controller.
8. Press down Joint #3 while pressing the brake release switch, and then check the lower limit position. Do not lower the mechanical stop too far. Otherwise, the joint may not reach a target position.
9. Calculate the lower limit pulse value of the pulse range using the formula shown below, and set the value.
 The result of the calculation is always negative because the lower limit Z coordinate value is negative.

GX10-B/GX10-C1S (Z: -180 mm): Lower limit of pulse = (-180)/50 × 131072 × (66/32) = -973210**

GX10-B/GX10-C4S (Z: -420 mm): Lower limit of pulse = (-420)/50 × 131072 × (66/32) = -2270823**

Example: To return the mechanical stop to its factory default position after being lowered by 80 mm with a stroke of 180 mm

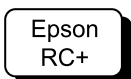

Execute the following command in [Command Window].

```
>JRANGE 3,-973210,0           'Sets the pulse range of Joint #3
```

10. Using the Pulse statement (Go Pulse statement), move Joint #3 to the lower limit position of the pulse range that was set at low speed.
 If the mechanical stop range is less than the pulse range, Joint #3 will hit the mechanical stop and an error will occur. When

an error occurs, either change the pulse range to a narrower setting or extend the position of the mechanical stop within the limit.

Example: To return the mechanical stop to its factory default position after being lowered by 80 mm with a stroke of 180 mm

Epson
RC+

Execute the following command in [Command Window].

```
>MOTOR ON           ' Turns on the motor
>SPEED 5           ' Sets to low speed
>PULSE 0,0,- 973210,0 ' Moves to the lower limit pulse position of Joint #3
```

(In this example, all pulses except those for Joint #3 are "0". Substitute these "0" values with the other pulse values to specify a position where interference will not occur even when lowering Joint #3.)

4.5.3 Setting the Rectangular Range in the XY Coordinate System of the Manipulator

(For Joints #1 and #2)

Use this procedure to set the upper and lower limits of the X and Y coordinates.

This setting is a software-based limit only, and so it does not change the maximum physical range. The maximum physical range is based on the position of the mechanical stops.

Epson
RC+

Go to [Tools] - [Robot Manager] - [XYZ Limits] panel, and make the setting.
This can also be set using the XYLim statement in [Command Window].

4.5.4 Standard Work Envelope

The following "work envelope" diagrams show the model with standard (maximum) specifications. When each joint motor is under servo control, the center of the Manipulator shaft's lowest point moves in the ranges shown in the figure.

- Range to mechanical stop
This is the range where the center of shaft's lowest point can be moved when each joint motor is not under servo control.
- Mechanical stop
This is the stop that sets the absolute work envelope where the Manipulator cannot move beyond mechanically.
- Maximum zone
This is the range that contains the farthest reach of the arms where interference can occur. If the maximum radius of the hand exceeds 60 mm, add the "Range to mechanical stop" and the "Radius of the hand." The total value is specified as the maximum zone.

Table top mounting specifications

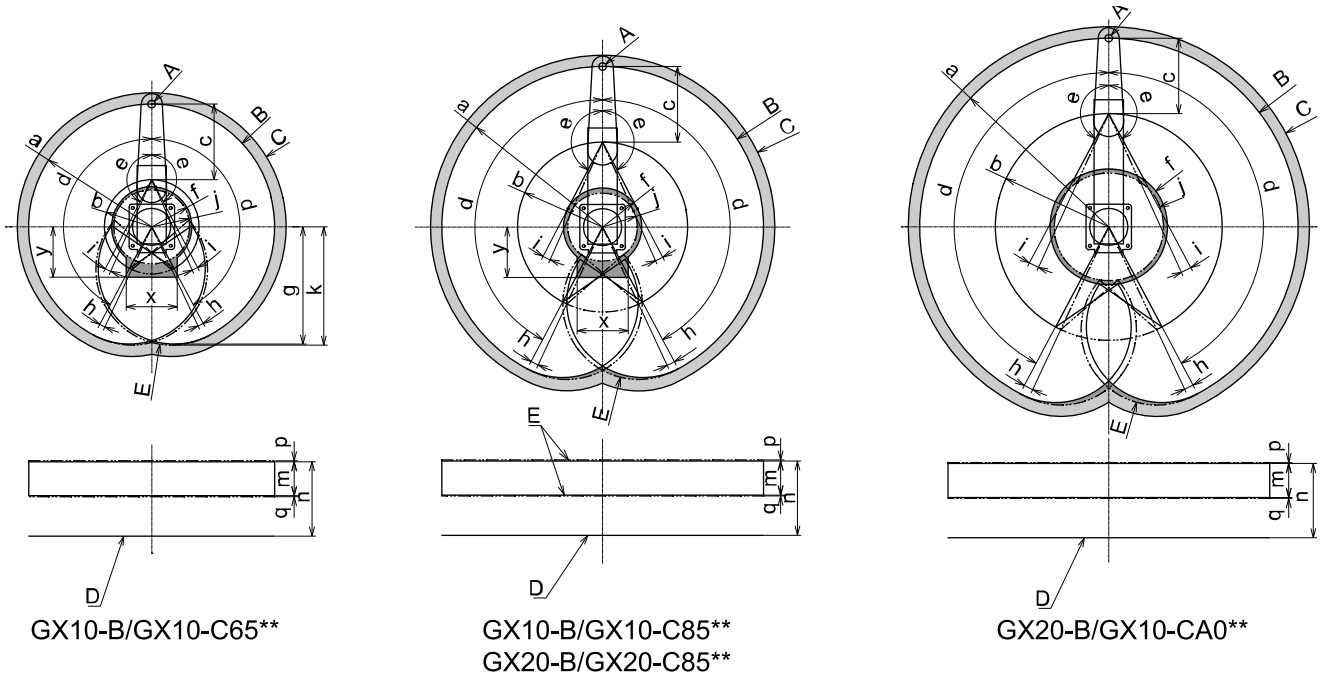

Symbol	Description
A	Center of Joint #3
B	Work envelope
C	Maximum zone
D	Base mounting surface
E	Range to mechanical stop

		GX10-B/GX10-C65**		GX10-B/GX10-C85** GX20-B/GX20-C85**		GX20-B/GX20-CA0**	
		S	C, P	S	C, P	S	C, P
a	Length of Arm #1 + Arm #2 (mm)	650		850		1000	
b	Length of Arm #1 (mm)	250		450		600	
c	Length of Arm #2 (mm)			400			
d	Joint #1 motion (°)			152			
e	Joint #2 motion (°)	152.5		152.5	$0 \geq Z \geq -360$	152.5	152.5
					$-360 > Z \geq -390$	151	
f	(Work envelope)	212.4		207.8	$0 \geq Z \geq -360$	207.8	307
					$-360 > Z \geq -390$	218.3	
g	(Work envelope of the back side)	620.7		797.3		929.8	

		GX10-B/GX10-C65**		GX10-B/GX10-C85** GX20-B/GX20-C85**		GX20-B/GX20-CA0**	
		S	C, P	S	C, P	S	C, P
h	Angle to the Joint #1 mechanical stop (°)	3					
i	Angle to the Joint #2 mechanical stop (°)	3.5	3.5	$0 \geq Z \geq -360$	3.5	3.5	
				$-360 > Z \geq -390$	5		
j	(Mechanical stop area)	199.4	183.3		285.4		
k	(Mechanical stop area of the back side)	626.6	807.8		943.8		
x	Dimensions of motion prohibited area (mm)	270				-	
y	Dimensions of motion prohibited area (mm)	267	292	267	292	-	

		GX10-B/GX10-C**1* GX20-B/GX20-C**1*		GX10-B/GX10-C**4* GX20-B/GX20-C**4*	
		S	C, P	S	C, P
m	Joint #3 work envelope	180	150	420	390
n	Distance from base mounting surface	393.5	355.5	393.5	355.5
p	Joint #3 mechanical stop area (upper limit)	5	1.8	5	1.8
q	Joint #3 mechanical stop area (lower limit)	5	1	5	1

Wall mounting specifications

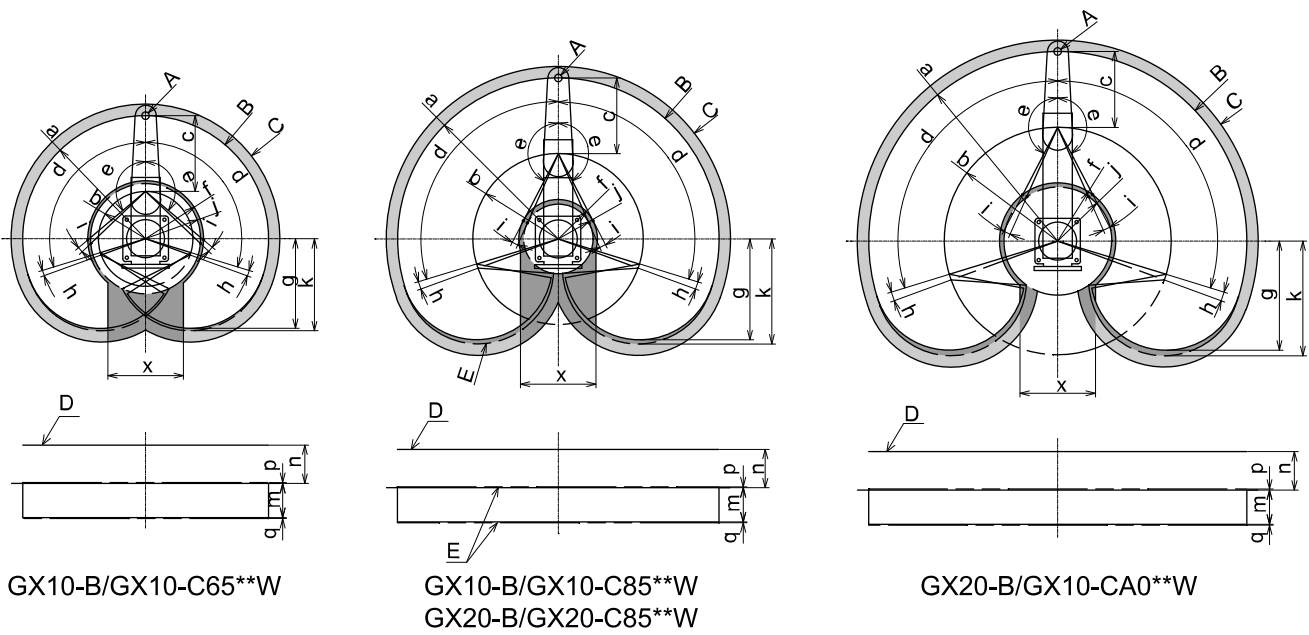

Symbol	Description
A	Center of Joint #3
B	Work envelope
C	Maximum zone
D	Base mounting surface
E	Range to mechanical stop

		GX10-B/GX10-C65**W		GX10-B/GX10-C85**W GX20-B/GX20-C85**W		GX20-B/GX20-CA0**W	
		S	C, P	S	C, P	S	C, P
a	Length of Arm #1 + Arm #2 (mm)	650		850		1000	
b	Length of Arm #1 (mm)	250		450		600	
c	Length of Arm #2 (mm)	400					
d	Joint #1 motion (°)	107					
e	Joint #2 motion (°)	130		152.5	151	152.5	
f	(Work envelope)	306.5		207.8	218.3	307	
g	(Work envelope of the back side)	473.1		531.6		575.4	
h	Angle to the Joint #1 mechanical stop (°)	3					
i	Angle to the Joint #2 mechanical stop (°)	3.5		3.5	5	3.5	

		GX10-B/GX10-C65**W		GX10-B/GX10-C85**W GX20-B/GX20-C85**W		GX20-B/GX20-CA0**W	
		S	C, P	S	C, P	S	C, P
j	(Mechanical stop area)	291.2		183.3		285.4	
k	(Mechanical stop area of the back side)	485.5		553.9		605.2	
x	Dimensions of motion prohibited area (mm)	400					
y	Dimensions of motion prohibited area (mm)	0 (infinite on back side)					

		GX10-B/GX10-C**1*W GX20-B/GX20-C**1*W		GX10-B/GX10-C**4*W GX20-B/GX20-C**4*W	
		S	C, P	S	C, P
m	Joint #3 work envelope	180	150	420	390
n	Distance from base mounting surface	202.5	240.5	202.5	240.5
p	Joint #3 mechanical stop area (upper limit)	5	1.8	5	1.8
q	Joint #3 mechanical stop area (lower limit)	5	1	5	1

Ceiling mounting specifications

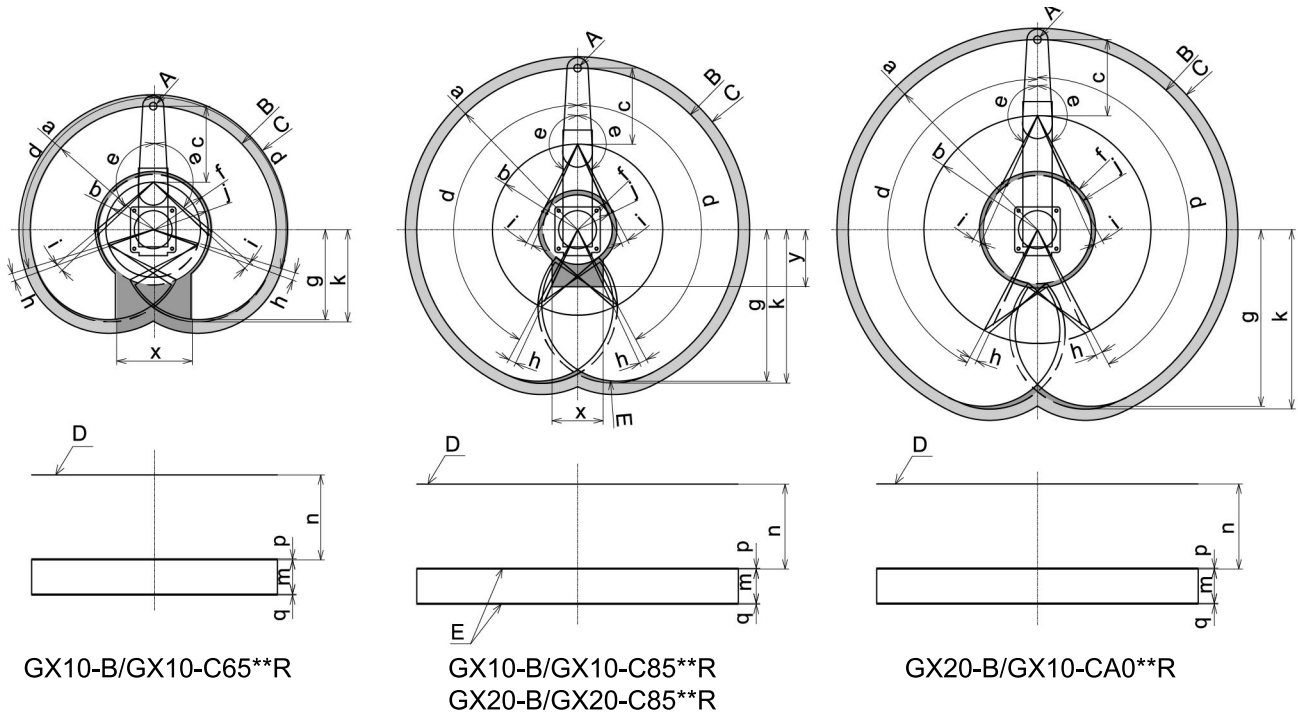

GX10-B/GX10-C65**R

GX10-B/GX10-C85**R
GX20-B/GX20-C85**R

GX20-B/GX10-CA0**R

Symbol	Description
A	Center of Joint #3
B	Work envelope
C	Maximum zone
D	Base mounting surface
E	Range to mechanical stop

		GX10-B/GX10-C65**R		GX10-B/GX10-C85**R GX20-B/GX20-C85**R		GX20-B/GX20-CA0**R	
		S	C, P	S	C, P	S	C, P
a	Length of Arm #1 + Arm #2 (mm)	650		850		1000	
b	Length of Arm #1 (mm)	250		450		600	
c	Length of Arm #2 (mm)	400					
d	Joint #1 motion (°)	107		152			
e	Joint #2 motion (°)	130		152.5	151	152.5	
f	(Work envelope)	306.5		207.8	218.3	307	
g	(Work envelope of the back side)	473.1		797.3		929.8	
h	Angle to the Joint #1 mechanical stop (°)	3					

		GX10-B/GX10-C65**R		GX10-B/GX10-C85**R GX20-B/GX20-C85**R		GX20-B/GX20-CA0**R	
		S	C, P	S	C, P	S	C, P
i	Angle to the Joint #2 mechanical stop (°)	3.5		3.5	5	3.5	
j	(Mechanical stop area)	291.2		183.3		285.4	
k	(Mechanical stop area of the back side)	485.5		807.8		943.8	
x	Dimensions of motion prohibited area (mm)	400		270		-	
y	Dimensions of motion prohibited area (mm)	0 (infinite on back side)		300		-	

		GX10-B/GX10-C**1*R GX20-B/GX20-C**1*R		GX10-B/GX10-C**4*R GX20-B/GX20-C**4*R	
		S	C, P	S	C, P
m	Joint #3 work envelope	180	150	420	390
n	Distance from base mounting surface	447.5	485.5	447.5	485.5
p	Joint #3 mechanical stop area (upper limit)	5	1.8	5	1.8
q	Joint #3 mechanical stop area (lower limit)	5	1	5	1

5. Periodic Inspection

Accurate inspection work is necessary to prevent breakdowns and ensure safety.

This section explains the inspection schedule and what should be inspected.

Perform inspections according to the predetermined schedule.

5.1 GX4 Manipulator Periodic Inspection

5.1.1 Inspection

5.1.1.1 Inspection Schedule

Inspection items are divided into five stages (daily, 1-month, 3-month, 6-month, and 12-month), with additional items added at each stage. However, if the Manipulator is powered and operated for more than 250 hours in a month, add inspection items every 250, 750, 1,500, and 3,000 hours.

	Inspection Item					
	Daily Inspection	1-month Inspection	3-month Inspection	6-month Inspection	12-month Inspection	Overhaul*
1-month inspection (250 hours)	Perform daily	✓				
2 months (500 hours)		✓				
3 months (750 hours)		✓	✓			
4 months (1,000 hours)		✓				
5 months (1,250 hours)		✓				
6 months (1,500 hours)		✓	✓	✓		
7 months (1,750 hours)		✓				
8 months (2,000 hours)		✓				
9 months (2,250 hours)		✓	✓			
10 months (2,500 hours)		✓				
11 months (2,750 hours)		✓				
12 months (3,000 hours)		✓	✓	✓	✓	
13 months (3,250 hours)		✓				
:	:	:	:	:	:	:
20,000 hours						✓

* Overhaul (parts replacement)

 **KEY POINTS**

An overhaul should be performed after every 20,000 hours of Manipulator operation. Assuming an operation time of 8 hours per day and 250 hours per month, an overhaul should be performed every 80 months.

5.1.1.2 Inspection Details

Inspection items

Inspection Item	Inspection Location	Daily Inspection	1-month Inspection	3-month Inspection	6-month Inspection	12-month Inspection
Loose bolts: Check for rattling	Hand mounting bolts	✓	✓	✓	✓	✓
	Manipulator installation bolts	✓	✓	✓	✓	✓
Check for loose connectors	Manipulator side external (Connector plate, etc.)	✓	✓	✓	✓	✓
Inspect for flaws: Clean off adhering debris, etc.	Entire Manipulator	✓	✓	✓	✓	✓
	External cables		✓	✓	✓	✓
Correct deformations and misalignments	Safety barriers, etc.	✓	✓	✓	✓	✓
Check brake operation	Joints #3 and #4	✓	✓	✓	✓	✓
Check for abnormal operation noise and vibration	Entire Manipulator	✓	✓	✓	✓	✓

Inspection methods

Inspection Item	Inspection Method
Check for loose or rattling bolts	Using an Allen wrench or similar tool, check that the hand mounting bolts and Manipulator installation bolts are not loose. If the bolts are loose, refer to the following section, and retighten to the proper torque. Tightening the Hexagon Socket Head Cap Bolts
Check for loose connectors	Check that no connectors are loose. If a connector is loose, reattach it so that it will not come off.
Inspect for flaws Clean off adhering debris, etc.	Check the appearance of the Manipulator, and clean off any dust or other foreign substances adhering to it. Check the appearance of the cables for any flaws, and make sure it is not disconnected.
Correct deformation and misalignment	Check for misalignment of safety barriers and other components. If it is misaligned, correct it to the original position.
Check brake operation	With the motor turned off, check that the shaft does not drop. If the shaft drops while the motor is turned off and the brake is not released, contact the supplier. Also, contact the supplier if the brakes do not release despite the brake release operation.
Check for abnormal operation noise and vibration	Check for any abnormal noises and vibrations during operation. If you notice anything unusual, contact the supplier.

5.1.2 Overhaul (Parts Replacement)

Overhauls (replacements) can only be performed by properly trained service engineers.

For details, refer to the following section.

"Safety Manual - Training"

 WARNING

To continue using the Manipulator safely and in accordance with the cleanroom and the ESD specifications and the ESD specifications, be sure to perform periodic overhauls of the cable unit, replacing damaged or worn-out parts. In accordance with the cleanroom and ESD specifications and the ESD specifications, the conduit tube is made of conductive materials to prevent static electricity. If the cables wear down over a long period of operation and cause an internal short circuit, the conduit tube may be electrified. Touching the conduit tube while the power is turned on could result in serious bodily injury due to electric shock.

5.1.3 Applying Grease

Ball screw splines and reduction gears require periodic greasing. Be sure to use the specified grease.

⚠ CAUTION

- Be careful that the grease does not run out. When grease runs out, scratches and other defects can occur on the slide, not only hindering maximum performance, but also requiring significant time and money to repair.
- If grease enters the eyes or mouth or adheres to the skin, take the following measures:
 - If it enters the eyes**
After rinsing the eyes thoroughly with clean water, seek medical attention.
 - If it enters the mouth**
If swallowed, do not force vomiting, and seek medical attention.
If the mouth is contaminated, rinse thoroughly with water.
 - If adhered to skin**
Rinse with water and soap.

	Part	Interval	Grease	Grease Application Procedure
Joint #1 Joint #2	Reduction gear	When overhaul is performed	-	This can be performed by properly trained service engineers only. For more information, please contact the supplier.
Joint #3	Ball screw spline unit	100 km (first 50 km) run	AFB*	"Applying grease to the ball screw spline unit" (See below.)

* Use the grease below.

Product name: THK AFB-LF Grease
 Manufacturer: THK Co., LTD.
 URL: <https://www.thk.com/>

Ball screw spline unit of Joint #3

The recommended interval to perform greasing is when the unit has run 100 km. However, the interval can also be confirmed from the grease state. As shown in the figure, apply grease when the grease turns black or has dried up.

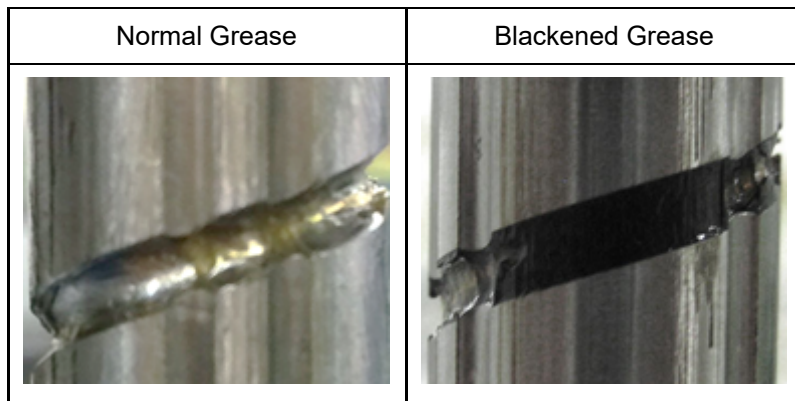

For the first time only, apply grease after running for 50 km.

 **KEY POINTS**

When using Epson RC+, the recommended interval for applying grease to the ball screw spline unit can be viewed from the [Maintenance] dialog box in Epson RC+.

Applying grease to the ball screw spline unit

	Name	Quantity	Remarks
Grease used	Grease for ball screw splines (AFB grease)	Appropriate amount	-
Tools used	Wiping cloth	1	For wiping off grease (Spline shaft)
	Phillips screwdriver	1	For removing the clamp band Cleanroom & ESD specifications only

 **KEY POINTS**

When applying grease, be careful to cover the hand and peripheral equipment so that, if any grease falls on them, it will not affect their performance.

1. Turn on the Controller.
2. Lower the shaft to the lower limit in one of the following ways.

 **KEY POINTS**

Make sure that the hand does not interfere with peripheral equipment or other objects.

- While pressing down the brake release switch, manually lower the shaft to the lower limit.

 **KEY POINTS**

When pressing the brake release switch, watch for the shaft descending or rotating under the weight of the hand.

- Using the Epson RC+ [Tools] - [Robot Manager] - [Jog & Teach] panel, lower the shaft to the lower limit.

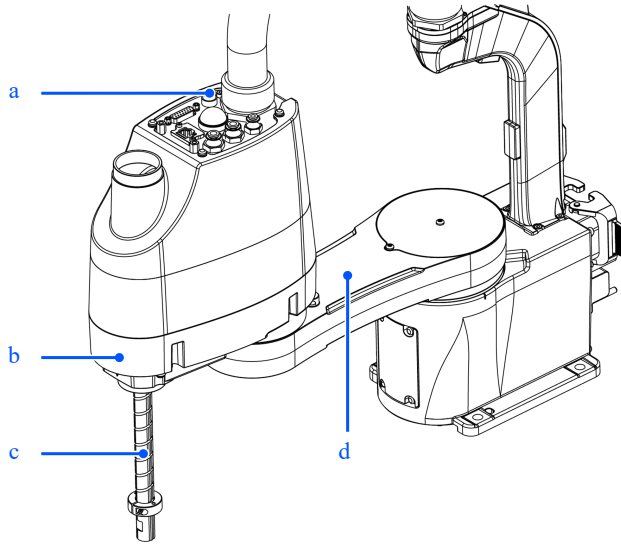

Symbol	Description
a	Joint #3 and Joint #4 brake release switch
b	Arm #2
c	Shaft
d	Arm #1

3. Turn off the Controller.

4. Wipe off the old grease on the shaft, and apply new grease.

The grease application area is from the end of the spline nut to the mechanical stop.

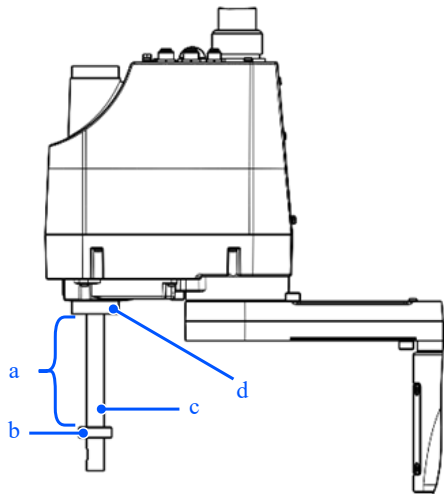

Symbol	Description
a	Application area
b	Mechanical stop
c	Shaft
d	Spline nut

5. Grease should be applied to the helical and vertical grooves of the ball screw spline so that the grooves are filled evenly.

Example of grease application



6. Turn on the Controller.

7. Start the Robot Manager, and move the shaft to the origin position. Be careful not to hit any peripheral equipment.

8. After moving to the origin position, perform a reciprocating motion with the shaft. The reciprocating motion is performed from the upper limit to the lower limit using the low-power mode operation program. Perform the motion for about 5 minutes to allow the grease to spread.

9. Turn on the Controller.

10. Wipe off any excess grease at the spline nut end and mechanical stop section.

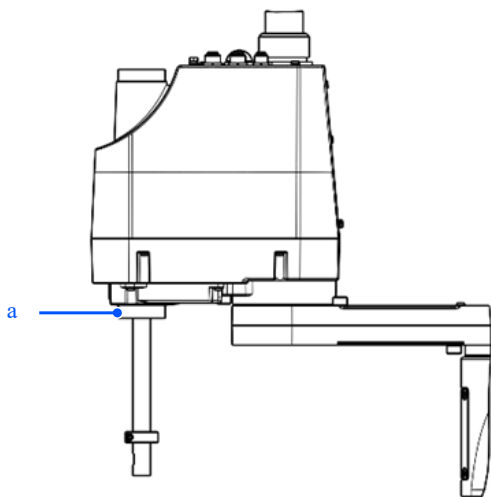

Symbol	Description
a	Spline nut end

5.1.4 Tightening the Hexagon Socket Head Cap Bolts

Hexagon socket head cap bolts (referred to as "bolts" below) are used in locations where mechanical strength is required. During assembly, these bolts are tightened at the tightening torques shown in the following table.

Unless otherwise specified, when retightening these bolts in the work procedures described in this manual, use a torque wrench or similar tool to obtain the tightening torques in the following table.

Bolt	Tightening Torque
M3	2.0 ± 0.1 N·m (21 ± 1 kgf·cm)
M4	4.0 ± 0.2 N·m (41 ± 2 kgf·cm)
M5	8.0 ± 0.4 N·m (82 ± 4 kgf·cm)
M6	13.0 ± 0.6 N·m (133 ± 6 kgf·cm)
M8	32.0 ± 1.6 N·m (326 ± 16 kgf·cm)
M10	58.0 ± 2.9 N·m (590 ± 30 kgf·cm)
M12	100.0 ± 5.0 N·m (1,020 ± 51 kgf·cm)

For set screws, refer to the following table.

Set Screw	Tightening Torque
M4	2.4 ± 0.1 N·m (26 ± 1 kgf·cm)
M5	3.9 ± 0.2 N·m (40 ± 2 kgf·cm)

It is recommended that bolts arranged in a circular pattern be secured in place by tightening in criss-cross order as shown in the figure.

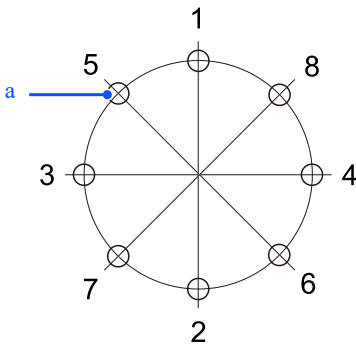

Symbol	Description
a	Bolt hole

When securing the bolts, do not tighten the bolts all at once, but tighten them in two or three separate rounds with an Allen wrench, and then use a torque wrench or similar tool to secure them at the tightening torques shown in the table above.

5.2 GX8 Manipulator Periodic Inspection

5.2.1 Inspection

5.2.1.1 Inspection Schedule

Inspection items are divided into five stages (daily, 1-month, 3-month, 6-month, and 12-month), with additional items added at each stage. However, if the Manipulator is powered and operated for more than 250 hours in a month, add inspection items every 250, 750, 1,500, and 3,000 hours.

	Inspection Item					
	Daily Inspection	1-month Inspection	3-month Inspection	6-month Inspection	12-month Inspection	Overhaul*
1-month inspection (250 hours)	Perform daily	✓				
2 months (500 hours)		✓				
3 months (750 hours)		✓	✓			
4 months (1,000 hours)		✓				
5 months (1,250 hours)		✓				
6 months (1,500 hours)		✓	✓	✓		
7 months (1,750 hours)		✓				
8 months (2,000 hours)		✓				
9 months (2,250 hours)		✓	✓			
10 months (2,500 hours)		✓				
11 months (2,750 hours)		✓				
12 months (3,000 hours)		✓	✓	✓	✓	
13 months (3,250 hours)		✓				
:	:	:	:	:	:	:
20,000 hours						✓

* Overhaul (parts replacement)

 **KEY POINTS**

An overhaul should be performed after every 20,000 hours of Manipulator operation. Assuming an operation time of 8 hours per day and 250 hours per month, an overhaul should be performed every 80 months.

5.2.1.2 Inspection Details

Inspection items

Inspection Item	Inspection Location	Daily Inspection	1-month Inspection	3-month Inspection	6-month Inspection	12-month Inspection
Loose bolts: Check for rattling	Hand mounting bolts	✓	✓	✓	✓	✓
	Manipulator installation bolts	✓	✓	✓	✓	✓
Check for loose connectors	Manipulator side external (Connector plate, etc.)	✓	✓	✓	✓	✓
Inspect for flaws: Clean off adhering debris, etc.	Entire Manipulator	✓	✓	✓	✓	✓
	External cables		✓	✓	✓	✓
Correct deformations and misalignments	Safety barriers, etc.	✓	✓	✓	✓	✓
Check brake operation	Joints #3 and #4	✓	✓	✓	✓	✓
Check for abnormal operation noise and vibration	Entire Manipulator	✓	✓	✓	✓	✓

Inspection methods

Inspection Item	Inspection Method
Check for loose or rattling bolts	Using an Allen wrench or similar tool, check that the hand mounting bolts and Manipulator installation bolts are not loose. Refer to the following section, and retighten to the proper torque. Tightening the Hexagon Socket Head Cap Bolts
Check for loose connectors	Check that no connectors are loose. If a connector is loose, reattach it so that it will not come off.
Inspect for flaws Clean off adhering debris, etc.	Check the appearance of the Manipulator, and clean off any dust or other foreign substances adhering to it. Check the appearance of the cables for any flaws, and make sure it is not disconnected.
Correct deformation and misalignment	Check for misalignment of safety barriers and other components. If it is misaligned, correct it to the original position.
Check brake operation	With the motor turned off, check that the shaft does not drop. If the shaft drops while the motor is turned off and the brake is not released, contact the supplier. Also, contact the supplier if the brakes do not release despite the brake release operation.
Check for abnormal operation noise and vibration	Check for any abnormal noises and vibrations during operation. If you notice anything unusual, contact the supplier.

5.2.2 Overhaul (Parts Replacement)

Overhauls (replacements) can only be performed by properly trained service engineers.
For details, refer to the following section.
"Safety Manual - Training"

5.2.3 Applying Grease

Ball screw splines and reduction gears require periodic greasing. Be sure to use the specified grease.

⚠ CAUTION

- Be careful that the grease does not run out. When grease runs out, scratches and other defects can occur on the slide, not only hindering maximum performance, but also requiring significant time and money to repair.
- If grease enters the eyes or mouth or adheres to the skin, take the following measures:
 - If it enters the eyes**
After rinsing the eyes thoroughly with clean water, seek medical attention.
 - If it enters the mouth**
If swallowed, do not force vomiting, and seek medical attention.
If the mouth is contaminated, rinse thoroughly with water.
 - If adhered to skin**
Rinse with water and soap.

	Part	Interval	Grease	Grease Application Procedure
Joint #1 Joint #2	Reduction gear	When overhaul is performed	-	This can be performed by properly trained service engineers only. For more information, please contact the supplier.
Joint #3	Ball screw spline unit	100 km (first 50 km) run	AFB*	"Applying grease to the ball screw spline unit" (See below.)

* Use the grease below.

Product name: THK AFB-LF Grease

Manufacturer: THK Co., LTD.

URL: <https://www.thk.com/>

For food grade grease model (GX8-B**3P-FZ), use the following grease.

Product name: THK L700 Grease

Ball screw spline unit of Joint #3

The recommended interval to perform greasing is when the unit has run 100 km. However, the interval can also be confirmed from the grease state. As shown in the figure, apply grease when the grease turns black or has dried up.

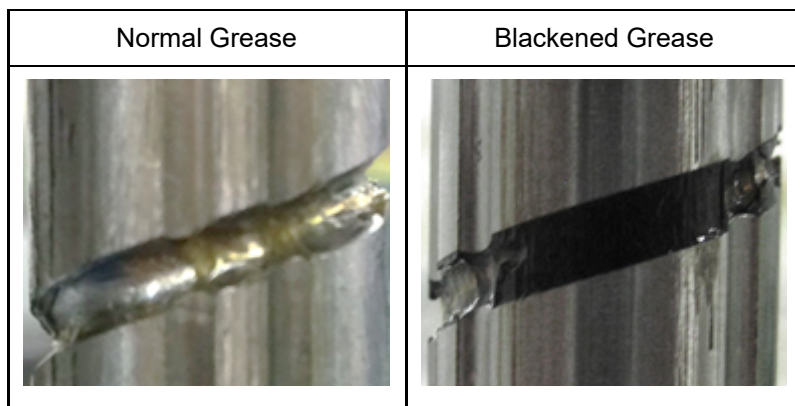

For the first time only, apply grease after running for 50 km.

KEY POINTS

When using Epson RC+, the recommended interval for applying grease to the ball screw spline unit can be viewed from the [Maintenance] dialog box in Epson RC+.

Applying grease to the ball screw spline unit

	Name	Quantity	Remarks
Grease used	Grease for ball screw splines (AFB grease)	Appropriate amount	-
	Grease for ball screw splines (L700 grease)	Appropriate amount	L700 grease is specified for food grade grease model.
Tools used	Wiping cloth	1	For wiping off grease (Spline shaft)
	Hook wrench	1	For removing the clamp band Cleanroom specifications and protected-model only

KEY POINTS

When applying grease, be careful to cover the hand and peripheral equipment so that, if any grease falls on them, it will not affect their performance.

1. Turn on the Controller.
2. Lower the shaft to the lower limit in one of the following ways.

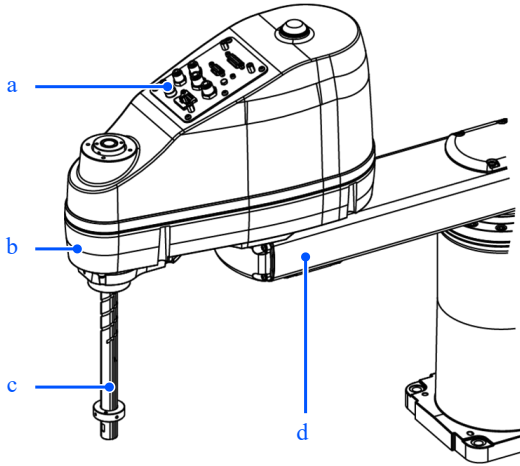

Symbol	Description
a	Joint #3 and Joint #4 brake release switch
b	Arm #2
c	Shaft
d	Arm #1

- While pressing down the brake release switch, manually lower the shaft to the lower limit.

KEY POINTS

When pressing the brake release switch, watch for the shaft descending or rotating under the weight of the hand.

- Using the Epson RC+ [Tools] - [Robot Manager] - [Jog & Teach] panel, lower the shaft to the lower limit.

KEY POINTS

Make sure that the hand does not interfere with peripheral equipment or other objects.

3. Turn off the Controller.
4. Wipe off the old grease on the shaft, and apply new grease.

The grease application area is from the end of the spline nut to the mechanical stop.

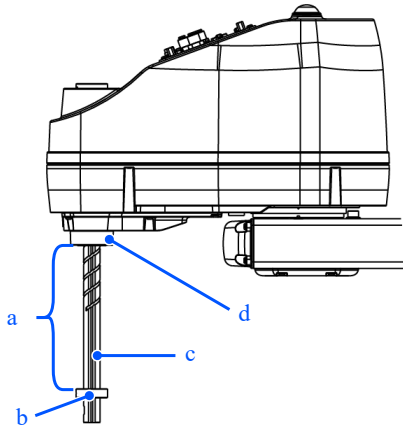

Symbol	Description
a	Application area
b	Mechanical stop
c	Shaft
d	Spline nut

5. Grease should be applied to the helical and vertical grooves of the ball screw spline so that the grooves are filled evenly.

Example of grease application



6. Turn on the Controller.

7. Start the Robot Manager, and move the shaft to the origin position. Be careful not to hit any peripheral equipment.

8. After moving to the origin position, perform a reciprocating motion with the shaft. The reciprocating motion is performed from the upper limit to the lower limit using the low-power mode operation program. Perform the motion for about 5 minutes to allow the grease to spread.

9. Turn on the Controller.

10. Wipe off any excess grease at the spline nut end and mechanical stop section.

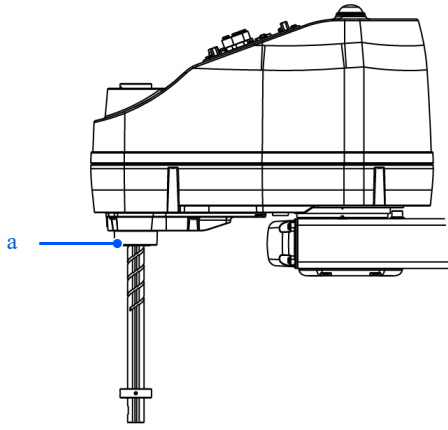

Symbol	Description
a	Spline nut end

5.2.4 Tightening the Hexagon Socket Head Cap Bolts

Hexagon socket head cap bolts (referred to as "bolts" below) are used in locations where mechanical strength is required. During assembly, these bolts are tightened at the tightening torques shown in the following table.

Unless otherwise specified, when retightening these bolts in the work procedures described in this manual, use a torque wrench or similar tool to obtain the tightening torques in the following table.

Bolt	Tightening Torque
M3	2.0 ± 0.1 N·m (21 ± 1 kgf·cm)
M4	4.0 ± 0.2 N·m (41 ± 2 kgf·cm)
M5	8.0 ± 0.4 N·m (82 ± 4 kgf·cm)
M6	13.0 ± 0.6 N·m (133 ± 6 kgf·cm)
M8	32.0 ± 1.6 N·m (326 ± 16 kgf·cm)
M10	58.0 ± 2.9 N·m (590 ± 30 kgf·cm)
M12	100.0 ± 5.0 N·m (1,020 ± 51 kgf·cm)

For set screws, refer to the following table.

Set Screw	Tightening Torque
M4	2.4 ± 0.1 N·m (26 ± 1 kgf·cm)
M5	3.9 ± 0.2 N·m (40 ± 2 kgf·cm)

It is recommended that bolts arranged in a circular pattern be secured in place by tightening in criss-cross order as shown in the figure.

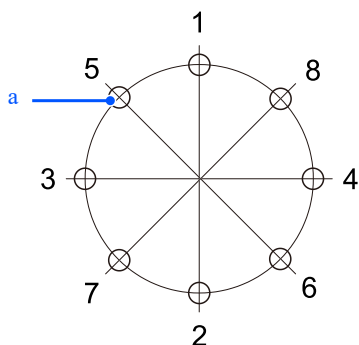

Symbol	Description
a	Bolt hole

When securing the bolts, do not tighten the bolts all at once, but tighten them in two or three separate rounds with an Allen wrench, and then use a torque wrench or similar tool to secure them at the tightening torques shown in the table above.

5.3 GX10/GX20 Manipulator Periodic Inspection

5.3.1 Inspection

5.3.1.1 Inspection Schedule

Inspection items are divided into five stages (daily, 1-month, 3-month, 6-month, and 12-month), with additional items added at each stage. However, if the Manipulator is powered and operated for more than 250 hours in a month, add inspection items every 250, 750, 1,500, and 3,000 hours.

	Inspection Item					
	Daily Inspection	1-month Inspection	3-month Inspection	6-month Inspection	12-month Inspection	Overhaul*
1-month inspection (250 hours)	Perform daily	✓				
2 months (500 hours)		✓				
3 months (750 hours)		✓	✓			
4 months (1,000 hours)		✓				
5 months (1,250 hours)		✓				
6 months (1,500 hours)		✓	✓	✓		
7 months (1,750 hours)		✓				
8 months (2,000 hours)		✓				
9 months (2,250 hours)		✓	✓			
10 months (2,500 hours)		✓				
11 months (2,750 hours)		✓				
12 months (3,000 hours)		✓	✓	✓	✓	
13 months (3,250 hours)		✓				
:	:	:	:	:	:	:
20,000 hours						✓

* Overhaul (parts replacement)

 **KEY POINTS**

An overhaul should be performed after every 20,000 hours of Manipulator operation. Assuming an operation time of 8 hours per day and 250 hours per month, an overhaul should be performed every 80 months.

5.3.1.2 Inspection Details

Inspection items

Inspection Item	Inspection Location	Daily Inspection	1-month Inspection	3-month Inspection	6-month Inspection	12-month Inspection
Loose bolts: Check for rattling	Hand mounting bolts	✓	✓	✓	✓	✓
	Manipulator installation bolts	✓	✓	✓	✓	✓
Check for loose connectors	Manipulator side external (Connector plate, etc.)	✓	✓	✓	✓	✓
Inspect for flaws: Clean off adhering debris, etc.	Entire Manipulator	✓	✓	✓	✓	✓
	External cables		✓	✓	✓	✓
Correct deformations and misalignments	Safety barriers, etc.	✓	✓	✓	✓	✓
Check brake operation	Joints #3 and #4	✓	✓	✓	✓	✓
Check for abnormal operation noise and vibration	Entire Manipulator	✓	✓	✓	✓	✓

Inspection methods

Inspection Item	Inspection Method
Check for loose or rattling bolts	Using an Allen wrench or similar tool, check that the hand mounting bolts and Manipulator installation bolts are not loose. Refer to the following section, and retighten to the proper torque. Tightening the Hexagon Socket Head Cap Bolts
Check for loose connectors	Check that no connectors are loose. If a connector is loose, reattach it so that it will not come off.
Inspect for flaws Clean off adhering debris, etc.	Check the appearance of the Manipulator, and clean off any dust or other foreign substances adhering to it. Check the appearance of the cables for any flaws, and make sure it is not disconnected.
Correct deformation and misalignment	Check for misalignment of safety barriers and other components. If it is misaligned, correct it to the original position.
Check brake operation	With the motor turned off, check that the shaft does not drop. If the shaft drops while the motor is turned off and the brake is not released, contact the supplier. Also, contact the supplier if the brakes do not release despite the brake release operation.
Check for abnormal operation noise and vibration	Check for any abnormal noises and vibrations during operation. If you notice anything unusual, contact the supplier.

5.3.2 Overhaul (Parts Replacement)

Overhauls (replacements) can only be performed by properly trained service engineers.
For details, refer to the following section.
"Safety Manual - Training"

5.3.3 Applying Grease

Ball screw splines and reduction gears require periodic greasing. Be sure to use the specified grease.

⚠ CAUTION

- Be careful that the grease does not run out. When grease runs out, scratches and other defects can occur on the slide, not only hindering maximum performance, but also requiring significant time and money to repair.
- If grease enters the eyes or mouth or adheres to the skin, take the following measures:
 - If it enters the eyes**
After rinsing the eyes thoroughly with clean water, seek medical attention.
 - If it enters the mouth**
If swallowed, do not force vomiting, and seek medical attention.
If the mouth is contaminated, rinse thoroughly with water.
 - If adhered to skin**
Rinse with water and soap.

	Part	Interval	Grease	Grease Application Procedure
Joint #1 Joint #2	Reduction gear	When overhaul is performed	-	This can be performed by properly trained service engineers only. For more information, please contact the supplier.
Joint #3	Ball screw spline unit	100 km (first 50 km) run	AFB*	"Applying grease to the ball screw spline unit" (See below.)

* Use the grease below.

Product name: THK AFB-LF Grease

Manufacturer: THK Co., LTD.

URL: <https://www.thk.com/>

Ball screw spline unit of Joint #3

The recommended interval to perform greasing is when the unit has run 100 km. However, the interval can also be confirmed from the grease state. As shown in the figure, apply grease when the grease turns black or has dried up.

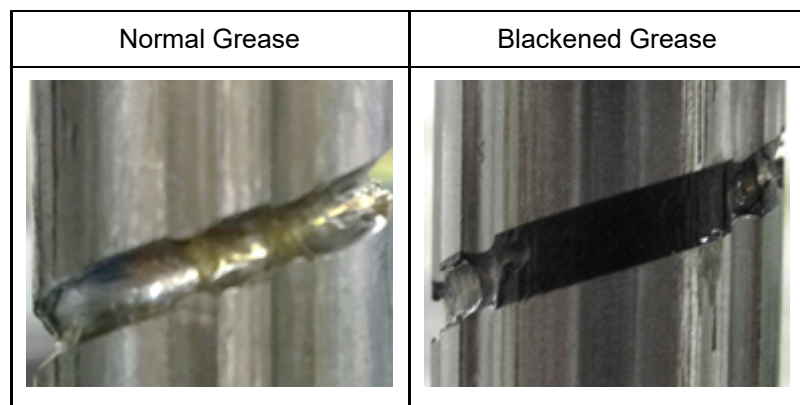

For the first time only, apply grease after running for 50 km.

KEY POINTS

When using Epson RC+, the recommended interval for applying grease to the ball screw spline unit can be viewed from the [Maintenance] dialog box in Epson RC+.

Applying grease to the ball screw spline unit

	Name	Quantity	Remarks
Grease used	Grease for ball screw splines (AFB grease)	Appropriate amount	-
Tools used	Wiping cloth	1	For wiping off grease (Spline shaft)
	Hook wrench	1	For removing the clamp band Cleanroom specifications and protected-model only

KEY POINTS

When applying grease, be careful to cover the hand and peripheral equipment so that, if any grease falls on them, it will not affect their performance.

1. Turn on the Controller.
2. Lower the shaft to the lower limit in one of the following ways.

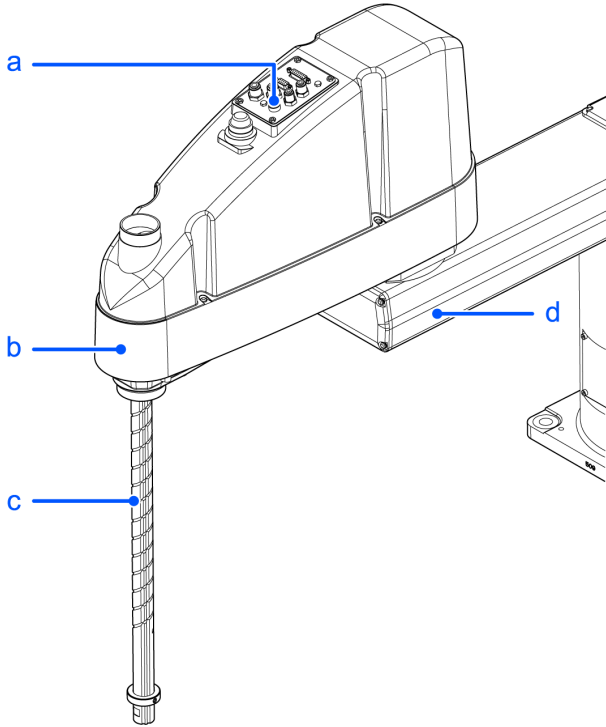

Symbol	Description
a	Joint #3 and Joint #4 brake release switch
b	Arm #2
c	Shaft
d	Arm #1

- While pressing down the brake release switch, manually lower the shaft to the lower limit.

KEY POINTS

When pressing the brake release switch, watch for the shaft descending or rotating under the weight of the hand.

- Using the Epson RC+ [Tools] - [Robot Manager] - [Jog & Teach] panel, lower the shaft to the lower limit.

KEY POINTS

Make sure that the hand does not interfere with peripheral equipment or other objects.

3. Turn off the Controller.
4. Wipe off the old grease on the shaft, and apply new grease.

The grease application area is from the end of the spline nut to the mechanical stop.

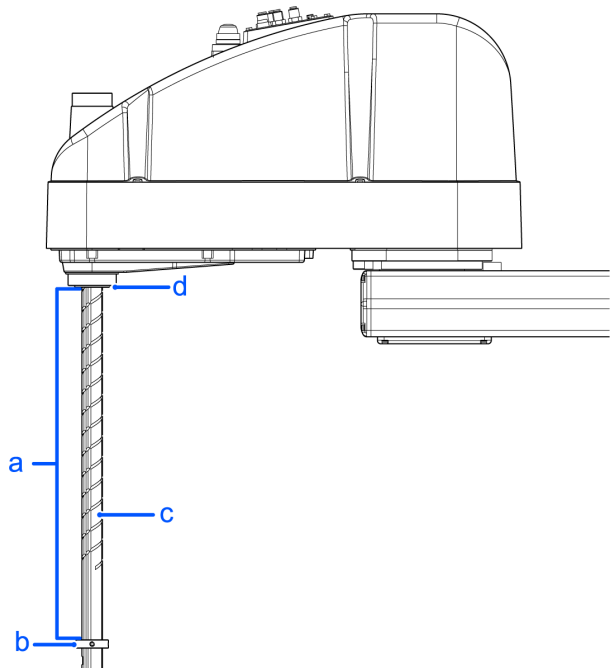

Symbol	Description
a	Application area
b	Mechanical stop
c	Shaft
d	Spline nut

5. Grease should be applied to the helical and vertical grooves of the ball screw spline so that the grooves are filled evenly.
Example of grease application



6. Turn on the Controller.
7. Start the Robot Manager, and move the shaft to the origin position. Be careful not to hit any peripheral equipment.

- 8. After moving to the origin position, perform a reciprocating motion with the shaft. The reciprocating motion is performed from the upper limit to the lower limit using the low-power mode operation program. Perform the motion for about 5 minutes to allow the grease to spread.
- 9. Turn on the Controller.
- 10. Wipe off any excess grease at the spline nut end and mechanical stop section.

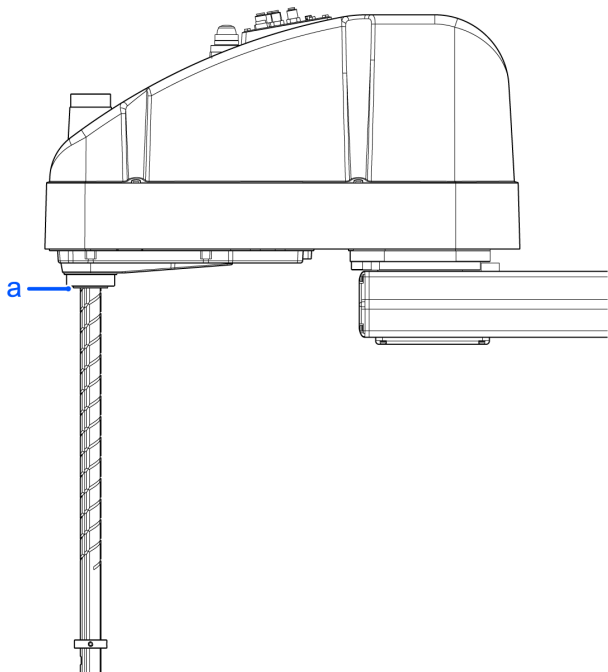

Symbol	Description
a	Spline nut end

5.3.4 Tightening the Hexagon Socket Head Cap Bolts

Hexagon socket head cap bolts (referred to as "bolts" below) are used in locations where mechanical strength is required. During assembly, these bolts are tightened at the tightening torques shown in the following table.

Unless otherwise specified, when retightening these bolts in the work procedures described in this manual, use a torque wrench or similar tool to obtain the tightening torques in the following table.

Bolt	Tightening Torque
M3	2.0 ± 0.1 N·m (21 ± 1 kgf·cm)
M4	4.0 ± 0.2 N·m (41 ± 2 kgf·cm)
M5	8.0 ± 0.4 N·m (82 ± 4 kgf·cm)
M6	13.0 ± 0.6 N·m (133 ± 6 kgf·cm)
M8	32.0 ± 1.6 N·m (326 ± 16 kgf·cm)
M10	58.0 ± 2.9 N·m (590 ± 30 kgf·cm)
M12	100.0 ± 5.0 N·m (1,020 ± 51 kgf·cm)

For set screws, refer to the following table.

Set Screw	Tightening Torque
M4	2.4 ± 0.1 N·m (26 ± 1 kgf·cm)
M5	3.9 ± 0.2 N·m (40 ± 2 kgf·cm)
M6	8.9 ± 0.4 N·m (82 ± 4 kgf·cm)

It is recommended that bolts arranged in a circular pattern be secured in place by tightening in criss-cross order as shown in the figure.

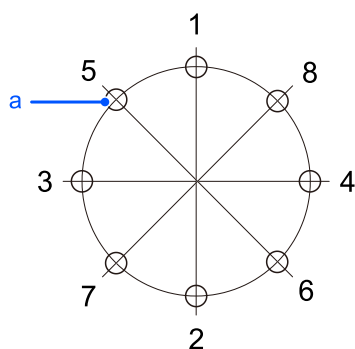

Symbol	Description
a	Bolt hole

When securing the bolts, do not tighten the bolts all at once, but tighten them in two or three separate rounds with an Allen wrench, and then use a torque wrench or similar tool to secure them at the tightening torques shown in the table above.

6. Appendix

This section provides detailed technical data such as the specifications, stopping time, and stopping distance for each model.

6.1 Appendix A: Specifications Table

6.1.1 GX4

Item		GX4-A/GX4-B/GX4-C****	GX4-A/GX4-B/GX4-C****M
Machinery name		Industrial robot	
Product series		GX	
Model		GX4-A****, GX4-B****, GX4-C**** <ul style="list-style-type: none"> ▪ Model Name GX4-A ▪ Model Name GX4-B ▪ Model Name GX4-C 	
Installation method		Table top mounting specifications	Multiple mounting specifications
Environmental specifications		ESD specifications, Cleanroom & ESD specifications *1	
Arm length	Arm #1 + Arm #2	25	250 mm
		30	300 mm
		35	350 mm
	Arm #3	150 mm: GX4-***1S*, E* 120 mm: GX4-***1C*	
Weight (not including weight of cables)	25	15 kg (33 lb)	-
	30	15 kg (33 lb)	17 kg (38 lb)
	35	16 kg (35 lb)	17 kg (38 lb)
Drive system	All joints	AC servo motor	
Maximum operating speed *2	Joint #1 + Joint #2	25	3,550 mm/s
		30	3,950 mm/s
		35	4,350 mm/s
	Joint #3	1,100 mm/s	
	Joint #4	3,100 deg/s	

Item			GX4-A/GX4-B/GX4-C****	GX4-A/GX4-B/GX4-C****M		
Repeatability	Joint #1 + Joint #2	25	±0.008 mm			
		30	±0.01 mm			
		35	±0.01 mm			
	Joint #3		±0.01 mm			
	Joint #4		±0.005 deg			
Max. motion range	Joint #1	25	±140 deg			
		30	±140 deg			
		35	Straight	±140 deg		
			Left-curved	-165 to +110 deg		
			Right-curved	-110 to +165 deg		
	Joint #2	25	S, E	±141 deg		
			C	±137 deg		
		30	S, E	±142 deg		
			C	±137 deg		
		35	Straight	±142 deg		
			Left-curved	S, E	-165 to +120 deg	
				C	-160 to +120 deg	
			Right-curved	S, E	-120 to +165 deg	
	C	-120 to +160 deg				
	Joint #3		S, E	150 mm		
			C	120 mm		
	Joint #4		±360 deg			
	Max. pulse range (pulse)	Joint #1	25	-		
			30	-1456356 to 6699236		
			35	Straight	-728178 to 5971058	
Left-curved				-873814 to 6116694		
Right-curved				-		
Joint #2		25	S, E	-2566827 to 2566827		
			C	-2494009 to 2494009		
		30	S, E	-2585032 to 2585032		
			C	-2457600 to 2457600		
				-2566827 to 2566827		

Item				GX4-A/GX4-B/GX4-C****	GX4-A/GX4-B/GX4-C****M	
		35	Straight	-2585032 to 2585032	-2585032 to 2585032	
			Left-curved	S, E	-3003734 to 2184534	-
				C	-2912712 to 2184534	-
			Right-curved	S, E	-2184534 to 3003734	-
				C	-2184534 to 2912712	-
			Joint #3			S, E
				C	0 to 1365334	
	Joint #4			±1310720		

Item		GX4-A/GX4-B/GX4-C*****
Resolution	Joint #1	0.0000343323 deg/pulse
	Joint #2	0.0000549316 deg/pulse
	Joint #3	0.0000878906 mm/pulse
	Joint #4	0.000274658 deg/pulse
Motor rated capacity	Joint #1	400 W
	Joint #2	150 W
	Joint #3	150 W
	Joint #4	150 W
Payload (load)	Rated	2 kg
	Max.	4 kg
Joint #4 allowable moment of inertia *3	Rating	0.005 kg·m ²
	Max.	0.05 kg·m ²
Shaft diameter	Outer	ø16 mm
	Inner	ø11 mm
Joint #3 press force		150 N
User wiring		15 (15-pin: D-sub)
		Ethernet CAT5e or equivalent
User piping		2 × ø6 mm pneumatic tube, Pressure resistance: 0.59 MPa (6 kgf/cm ² : 86 psi)
		1 × ø4 mm pneumatic tube, Pressure resistance: 0.59 MPa (6 kgf/cm ² : 86 psi)
Environmental requirements	Ambient temperature *4	5 to 40°C
	Ambient relative humidity	10 to 80% (no condensation)
Transportation and storage	Temperature	-20 to +60°C
	Humidity	10 to 90% (no condensation)
Noise level *5		LAeq = 71 dB(A)
Compatible Controllers		<ul style="list-style-type: none"> ▪ GX4-A: RC700-D ▪ GX4-B: RC700-E ▪ GX4-C: RC800-A
Operation mode *6		Standard mode (default), Boost mode
Setting value range	Speed	1 to (5) to 100
	Accel *7	1 to (10) to 100
	SpeedS	1 to (50) to 2000

Item		GX4-A/GX4-B/GX4-C*****	
()Default value	AccelS	1 to (200) to 25000	
	Fine	0 to (10000) to 65535	
	Weight	0 to (2) to 4	
M/C cable	Cable weight (cable only)	For fixing and signal (common to all lengths)	0.06 kg/m
		For fixing and power (common to all lengths)	0.30 kg/m
		For movable and signal (common to all lengths)	0.07 kg/m
		For movable and power (common to all lengths)	0.36 kg/m
	Cable outer diameter	For fixing and signal (common to all lengths)	ø6.5 mm (typ)
		For fixing and power (common to all lengths)	ø13.7 mm (typ)
		For movable and signal (common to all lengths)	ø6.4 mm (typ)
		For movable and power (common to all lengths)	ø13.7 mm (typ)
	Minimum bending radius *8	For fixing and signal (common to all lengths)	40 mm
		For fixing and power (common to all lengths)	83 mm
		For movable and signal (common to all lengths)	100 mm
		For movable and power (common to all lengths)	100 mm

*1: Manipulators with cleanroom & ESD specifications discharge the exhaust inside of the base and inside of the arm cover section together.

Consequently, if there is a gap in the base section, the arm tip section will not be fully negative pressurized, which may result in dust generation. Do not remove the maintenance cover on the front of the base. Connect the exhaust tube to the exhaust port on the back (or bottom) of the base.

If the exhaust discharge rate is not sufficient, dust generation will exceed the specifications.

- Cleanliness:
 - Class ISO 3 (ISO 14644-1)
- Exhaust
 - Exhaust port dimensions: Inner diameter ø6 mm
 - Compatible exhaust tubes
 - Polyurethane tubes
 - Outer diameter ø6 mm (Inner diameter ø4 mm)
 - Recommended exhaust discharge rate: About 1,000 cm³/s (standard state)

ESD specifications are specifications that use conductive materials for or apply plating to the major resin parts as anti-static measures.

We have confirmed that the Manipulator tip (tool mounting section) is at ± 5 V or less, even directly after the measuring operation according to Seiko Epson standards.

If you need any other detailed information, please contact the supplier.

Also, please check the amount of charge on any hand, wiring, or the like that you will attach to the robot on your own before use.

*2: When PTP statements are used. The maximum operating speed in CP motion is 2,000 mm/s in the horizontal plane.

*3: When the center of gravity of the load matches the Joint #4 center position

When the center of gravity position is separated from the Joint #4 center position, set the parameter using the Inertia statement.

*4: When used in a low-temperature environment near the minimum temperature specified in the product specifications, or when the unit is idle for a long period of time during holidays or at night, a collision detection error or similar error may occur immediately after the start of operation due to high resistance in the drive unit.

In such cases, warm-up operation for about 10 minutes is recommended.

*5: The conditions at measurement are as follows.

- Manipulator operating conditions
Rated load, four-joint simultaneous operation, maximum speed, maximum acceleration/deceleration
- Measurement locations
Manipulator rear side, 1,000 mm away from work envelope, and 50 mm above base mounting surface

*6: The PerformMode command can be used to switch operation modes. For details, refer to the following manual.

"Epson RC+ SPEL+ Language Reference"

KEY POINTS

Boost mode reduces the amount of time for a single operation compared to Standard mode; however, it worsens the operation duty and the vibration when stopping operation. Use it with caution.

*7: The Accel setting of "100" is the optimum setting that balances acceleration/deceleration and vibration during positioning.

*8: Note the following points when wiring the movable M/C cable.

- Install the cable not to apply a load to the connector.
- Bend the cable at the minimum bending radius of the movable part or more. The bending radius (a) and dimensions are shown in the figure below.

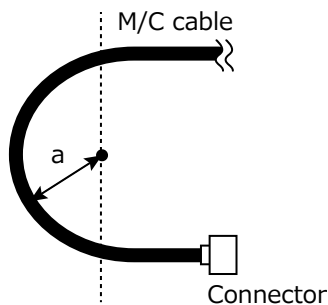

6.1.2 GX8

Item			GX8-A/GX8-B/GX8-C****	GX8-A/GX8-B/GX8-C****R	GX8-A/GX8-B/GX8-C****W
Machinery name		Industrial robot			
Product series		GX			
Model		GX8-A****, GX8-B****, GX8-C**** <ul style="list-style-type: none"> ▪ Model Name GX8-A ▪ Model Name GX8-B ▪ Model Name GX8-C 			
Installation method		Table top mounting specifications	Ceiling mounting specifications	Wall mounting specifications	
Environmental specifications		ESD specifications, Cleanroom & ESD specifications ^{*1} , Protected-model ^{*2}			
Arm length	Arm #1 + Arm #2	45	450 mm		
		55	550 mm		
		65	650 mm		
	Arm #3	2	200 mm: GX8-***2S*, E* 170 mm: GX8-***2C*, P*		
		3	330 mm: GX8-***3S*, E* 300 mm: GX8-***3C*, P*		
Weight (not including weight of cables)		45	33 kg (73 lb)		35 kg (77 lb)
		55	34 kg (75 lb)		36 kg (79 lb)
		65	35 kg (77 lb)		37 kg (82 lb)
Drive system	All joints	AC servo motor			
Maximum operating speed ^{*3}	Joint #1 + Joint #2	45	7,450 mm/s		
		55	8,450 mm/s		
		65	9,460 mm/s		
	Joint #3	2	2,350 mm/s		
		3	2,350 mm/s		
Joint #4		2,800 deg/s			
Repeatability	Joint #1 + Joint #2		±0.015 mm		
	Joint #3		±0.01 mm		
	Joint #4		±0.005 deg		

Item			GX8-A/GX8-B/GX8-C****	GX8-A/GX8-B/GX8-C****R	GX8-A/GX8-B/GX8-C****W	
Max. motion range	Joint #1	45	±152 deg	±105 deg	±105 deg	
		55		±152 deg	±135 deg	
		65		±148 deg		
	Joint #2	45	±142 to 147.5 deg *a	±125 deg		
		55	±145 to 147.5 deg *a	±147.5 deg: S*, E*		
		65	±147.5 deg	±145 deg: C*, P*		
	Joint #3	2	200 mm: GX8-***2S*, E* 170 mm: GX8-***2C*, P*			
		3	330 mm: GX8-***3S*, E* 300 mm: GX8-***3C*, P*			
	Joint #4			±360 deg		
	Max. pulse range (pulse)	Joint #1	45	-1128676 to +4405476	-273067 to +3549867	-273067 to +3549867
55			-1128676 to +4405476		-819200 to +4096000	
65					-1055858 to +4332658	
Joint #2		45	±2503111 to ±2685156 *a	±2275556		
		55	±2639644 to ±2685156 *a	±2685156: S*, E*		
		65	±2685156	±2639645: C*, P*		
Joint #3		2	-1092267: GX8-***2S*, E* -928427: GX8-***2C*, P*			
		3	-1802240: GX8-***3S*, E* -1638400: GX8-***3C*, P*			
Joint #4			±1668189			

*a: GX8-*45***、GX8-*55*** Joint #2

		Max. Motion Range	Max. Pulse Range
GX8-A/GX8-B/GX8-C45*S*,E*	0 ≥ Z ≥ -270	±147.5 deg	±2685156 pulse
	-270 > Z ≥ -330	±145 deg	±2639644 pulse
GX8-A/GX8-B/GX8-C45*C*,P*	0 ≥ Z ≥ -240	±147.5 deg	±2685156 pulse
	-240 > Z ≥ -300	±137.5 deg	±2503111 pulse
GX8-A/GX8-B/GX8-C55*C*,P*	0 ≥ Z ≥ -240	±147.5 deg	±2685156 pulse
	-240 > Z ≥ -300	±145 deg	±2639644 pulse

Item		GX8-A/GX8-B/GX8-C*****	
Resolution	Joint #1	0.0000549 deg/pulse	
	Joint #2	0.0000549 deg/pulse	
	Joint #3	2	0.0001831 mm/pulse
		3	0.0001831 mm/pulse
	Joint #4	0.0002140 deg/pulse	
Motor rated capacity	Joint #1	750 W	
	Joint #2	600 W	
	Joint #3	200 W	
	Joint #4	200 W	
Payload (load)	Rated	4 kg	
	Max.	8 kg	
Joint #4 allowable moment of inertia *4	Rating	0.01 kg·m ²	
	Max.	0.16 kg·m ²	
Shaft diameter	Outer	ø20 mm	
	Inner	ø14 mm	
Joint #3 press force		150 N	
User wiring	24 (15 pin + 9 pin: D-sub)		
	Ethernet CAT5e or equivalent		
User piping	2 × ø6 mm pneumatic tube, Pressure resistance: 0.59 MPa (6 kgf/cm ² : 86 psi)		
	2 × ø4 mm pneumatic tube, Pressure resistance: 0.59 MPa (6 kgf/cm ² : 86 psi)		
Environmental requirements	Ambient temperature *5	5 to 40°C	
	Ambient relative humidity	10 to 80% (no condensation)	
Transportation and storage	Temperature	-20 to +60°C	
	Humidity	10 to 90% (no condensation)	
Noise level *6		L _{Aeq} = 74 dB(A)	
Compatible Controllers		<ul style="list-style-type: none"> ▪ GX8-A: RC700-D ▪ GX8-B: RC700-E ▪ GX8-C: RC800-A 	
Operation mode *7		Standard mode (default), Boost mode	

Item		GX8-A/GX8-B/GX8-C*****	
Setting value range ()Default value	Speed	1 to (5) to 100	
	Accel *8	1 to (10) to 100	
	SpeedS	1 to (50) to 2000	
	AccelS	1 to (200) to 25000	
	Fine	0 to (10000) to 65535	
	Weight	0 to (4) to 8	
M/C cable	Cable weight (cable only)	For fixing and signal (common to all lengths)	0.06 kg/m
		For fixing and power (common to all lengths)	0.30 kg/m
		For movable and signal (common to all lengths)	0.07 kg/m
		For movable and power (common to all lengths)	0.36 kg/m
	Cable outer diameter	For fixing and signal (common to all lengths)	ø6.5 mm (typ)
		For fixing and power (common to all lengths)	ø13.7 mm (typ)
		For movable and signal (common to all lengths)	ø6.4 mm (typ)
		For movable and power (common to all lengths)	ø13.7 mm (typ)
	Minimum bending radius *9	For fixing and signal (common to all lengths)	40 mm
		For fixing and power (common to all lengths)	83 mm
		For movable and signal (common to all lengths)	100 mm
		For movable and power (common to all lengths)	100 mm

*1: Manipulators with cleanroom & ESD specifications (GX8-A/GX8-B/GX8-C***C*) discharge the exhaust inside of the base and inside of the arm cover together.

Connect the exhaust tube to the exhaust port on the back (or bottom) of the base.

If the exhaust discharge rate is not sufficient, dust generation will exceed the specifications.

- Cleanliness:
 - Class ISO 3 (ISO 14644-1)
- Exhaust
 - Exhaust port dimensions: Inner diameter ø 12 mm
 - Compatible exhaust tubes
 - Polyurethane tubes
 - Outer diameter ø12 mm (Inner diameter ø8 mm)

- Recommended exhaust discharge rate: About 1,000 cm³/s (standard state)

ESD specifications (GX8-A/GX8-B/GX8-C***E*) are specifications that use conductive materials for or apply plating to the major resin parts as anti-static measures.

We have confirmed that the Manipulator tip (tool mounting section) is at ±5 V or less, even directly after the measuring operation according to Seiko Epson standards.

If you need any other detailed information, please contact the supplier.

Also, please check the amount of charge on any hand, wiring, or the like that you will attach to the robot on your own before use.

*2: The IP (International Protection) rating for Manipulators with protected-models is an international standard indicating the degree of protection against dust and water.

Model	Protection Class		
GX8-A/GX8-B/GX8-C***P*	IP65	Dust protection level: 6	No ingress of dust
		Water protection level: 5	Water which is directed against the enclosure from any direction as a jet shall not have any harmful effects or impair performance.

*3: When PTP statements are used

The maximum operating speed in CP motion is 2,000 mm/s in the horizontal plane.

*4: When the center of gravity of the load matches the Joint #4 center position

When the center of gravity position is separated from the Joint #4 center position, set the parameter using the Inertia statement.

*5: When used in a low-temperature environment near the minimum temperature specified in the product specifications, or when the unit is idle for a long period of time during holidays or at night, a collision detection error or similar error may occur immediately after the start of operation due to high resistance in the drive unit.

In such cases, warm-up operation for about 10 minutes is recommended.

*6: The conditions at measurement are as follows.

- Manipulator operating conditions:
Rated load, four-joint simultaneous operation, maximum speed, maximum acceleration/deceleration
- Measurement locations
Manipulator rear side, 1,000 mm away from work envelope, and 50 mm above base mounting surface

*7: The PerformMode command can be used to switch operation modes. For details, refer to the following manual.

"Epson RC+ SPEL+ Language Reference"

KEY POINTS

Boost mode reduces the amount of time for a single operation compared to Standard mode; however, it worsens the operation duty and the vibration when stopping operation. Use it with caution.

*8: The Accel setting of "100" is the optimum setting that balances acceleration/deceleration and vibration during positioning.

*9: Note the following points when wiring the movable M/C cable.

- Install the cable not to apply a load to the connector.

- Bend the cable at the minimum bending radius of the movable part or more. The bending radius (a) and dimensions are shown in the figure below.

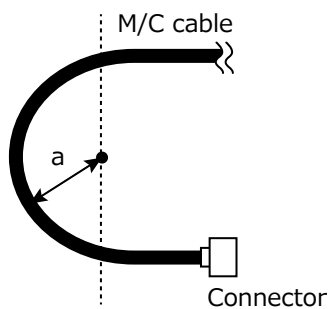

Item	GX8-B**3P-FZ
Food grade grease model	Food grade grease model have the grease for Z-axis ball screw splines which is usable for foods. Be sure to use the specified grease(L700) for food specification machine.

6.1.3 GX10/20

Item		GX10-B/GX10-C**** GX20-B/GX20-C****	GX10-B/GX10-C****R GX20-B/GX20-C****R	GX10-B/GX10-C****W GX20-B/GX20-C****W
Machinery name		Industrial robot		
Product series		GX		
Model		GX10-B*****, GX10-C*****, GX20-B*****, GX20-C***** <ul style="list-style-type: none"> ▪ Model Name GX10-B/GX20-B ▪ Model Name GX10-C/GX20-C 		
Installation method		Table top mounting specifications	Ceiling mounting specifications	Wall mounting specifications
Environmental specifications		Cleanroom specifications & ESD* ¹ , Protected-model* ²		
Arm length	Arm #1 + Arm #2	65	650 mm (GX10-B/GX10-C only)	
		85	850 mm (GX10-B/GX10-C/GX20-B/GX20-C)	
		A0	1000 mm (GX20-B/GX20-C only)	
	Arm #3	1	180 mm: GX10-B/GX10-C/GX20-B/GX20-C**1S* 150 mm: GX10-B/GX10-C/GX20-B/GX20-C**1C*, P*	
		4	420 mm: GX10-B/GX10-C/GX20-B/GX20-C**4S* 390 mm: GX10-B/GX10-C/GX20-B/GX20-C**4C*, P*	
Weight (not including weight of cables)		65	46 kg (102 lb)	51 kg (113 lb)
		85	49 kg (108 lb)	53 kg (117 lb)
		A0	50 kg (111 lb)	55 kg (122 lb)
Drive system	All joints	AC servo motor		
Maximum operating speed * ³	Joint #1 + Joint #2	65	8800 mm/s	
		85	11000 mm/s	
		A0	11500 mm/s	
	Joint #3	2350 mm/s		
	Joint #4	2400 deg/s (GX10-B/GX10-C only) 1700 deg/s (GX20-B/GX20-C only)		
Repeatability	Joint #1 + Joint #2	±0.025 mm		
	Joint #3	±0.01 mm		
	Joint #4	±0.005 deg		

Item			GX10-B/GX10-C**** GX20-B/GX20-C****	GX10-B/GX10-C****R GX20-B/GX20-C****R	GX10-B/GX10-C****W GX20-B/GX20-C****W
Max. motion range (deg.)	Joint #1	65	±152 deg	±107 deg	±107deg
		85		±152 deg	
		A0			
	Joint #2	65	±152.5 deg *a	±130 deg	
		85		±152.5 deg *a	
		A0			
	Joint #3	1	180 mm: GX10-B/GX10-C/GX20-B/GX20-C**1S* 150 mm: GX10-B/GX10-C/GX20-B/GX20-C**1C*, P*		
		4	420 mm: GX10-B/GX10-C/GX20-B/GX20-C**4S* 390 mm: GX10-B/GX10-C/GX20-B/GX20-C**4C*, P*		
	Joint #4		±360 deg		
	Max. pulse range (pulse)	Joint #1	65	-1805881 to +7048761	-495161 to +5738041
85			-1805881 to 7048761		
A0					
Joint #2		65	±2776178 *a	±2366578	
		85		±2776178 *a	
		A0			
Joint #3		1	-973210: GX10-B/GX10-C/GX20-B/GX20-C**1S* -811008: GX10-B/GX10-C/GX20-B/GX20-C**1C*, P*		
		4	-2270823: GX10-B/GX10-C/GX20-B/GX20-C**4S* -2108621: GX10-B/GX10-C/GX20-B/GX20-C**4C*, P*		
Joint #4		±1951517 (GX10-B/GX10-C only) ±2752512 (GX20-B/GX20-C only)			

 KEY POINTS

The length of Arm #1 + Arm #2 varies depending on the model.

- 65: 650 mm GX10-B/GX10-C only
- 85: 850 mm GX10-B/GX10-C/GX20-B/GX20-C
- A0: 1000 mm GX20-B/GX20-C only

*a: For Manipulators in table below (Joint #2)

	Max. Motion Range	Max. Pulse Range
GX10-B/GX10-C/GX20-B/GX20-C85*C, P (Z: -360 to -390 only) GX10-B/GX10-C/GX20-B/GX20-C85*CW, PW GX10-B/GX10-C/GX20-B/GX20-C85*CR, PR	±151 deg	±2748872

Item		GX10-B/GX10-C*****	GX20-B/GX20-C*****
Resolution	Joint #1	0.0000343 deg/pulse	
	Joint #2	0.0000549 deg/pulse	
	Joint #3	0.000185 mm/pulse	
	Joint #4	0.0001845 deg/pulse	0.0001308 deg/pulse
Motor rated capacity	Joint #1	750 W	
	Joint #2	600 W	
	Joint #3	400 W	
	Joint #4	150 W	
Payload (load)	Rated	5 kg	10 kg
	Max.	10 kg	20 kg
Joint #4 allowable moment of inertia *4	Rating	0.02 kg·m ²	0.05 kg·m ²
	Max.	0.25 kg·m ²	0.45 kg·m ²
Shaft diameter	Outer	ø25 mm	
	Inner	ø18 mm * Manipulators with cleanroom & ESD specifications or protected-model: upper end of shaft ø14 mm	
Joint #3 press force		250 N	
User wiring		24 pin (15 pin + 9 pin: D-sub)	
User piping		2 × ø6 mm pneumatic tube, Pressure resistance: 0.59 MPa (6 kgf/cm ² : 86 psi)	
		2 × ø4 mm pneumatic tube, Pressure resistance: 0.59 MPa (6 kgf/cm ² : 86 psi)	
Environmental requirements *5	Ambient temperature	5 to 40 °C	
	Ambient relative humidity	10 to 80% (no condensation)	
Transportation and storage	Temperature	-20 to +60°C	
	Humidity	10 to 90% (no condensation)	
Noise level *6		LAeq = 73 dB (A)	
Compatible Controllers		GX10-B, GX20-B: RC700-E GX10-C, GX20-C: RC800-A	
Setting value range()Default value	Speed	1 to (3) to 100	
	Accel *7	1 to (10) to 120	
	SpeedS	1 to (50) to 2000	
	AccelS	1 to (200) to 25000	
	Fine	0 to (10000) to 65535	

Item		GX10-B/GX10-C*****	GX20-B/GX20-C*****
	Weight	0 ~ (5) ~ 10	0 ~ (10) ~ 20
M/C cable	Cable weight (cable only)	For fixing and signal (common to all lengths)	0.06 kg/m
		For fixing and power (common to all lengths)	0.30 kg/m
		For movable and signal (common to all lengths)	0.07 kg/m
		For movable and power (common to all lengths)	0.36 kg/m
	Cable outer diameter	For fixing and signal (common to all lengths)	ø6.5 mm (typ)
		For fixing and power (common to all lengths)	ø13.7 mm (typ)
		For movable and signal (common to all lengths)	ø6.4 mm (typ)
		For movable and power (common to all lengths)	ø13.7 mm (typ)
	Minimum bending radius *8	For fixing and signal (common to all lengths)	40 mm
		For fixing and power (common to all lengths)	83 mm
		For movable and signal (common to all lengths)	100 mm
		For movable and power (common to all lengths)	100 mm

*1: Manipulators with cleanroom & ESD specifications (GX10-B/GX10-C/GX20-B/GX20-C***C*) discharge exhaust inside the base and inside the arm cover together.

Consequently, if there is a gap in the base section, the arm tip section will not be sufficiently negatively pressurized, which may result in dust generation.

Do not remove the maintenance cover on the front of the base.

Connect the exhaust tube to the exhaust port on the back (or bottom) of the base.

If the exhaust discharge rate is not sufficient, dust generation will exceed the specifications.

Fasten the exhaust port and exhaust tube firmly with vinyl tape to prevent gaps.

- Cleanliness:
Class ISO 3 (ISO 14644-1)
- Exhaust
 - Exhaust port dimensions: Inner diameter ø12 mm, outer diameter ø16 mm
 - Compatible exhaust tubes
 - Polyurethane tubes
 - Outer diameter ø12 mm (inner diameter ø8 mm) or inner diameter ø16 mm or more
 - Recommended exhaust discharge rate: About 1000 cm³/s (standard state)

ESD specifications are specifications that use conductive materials for or apply plating to the major resin parts as anti-static measures.

We have confirmed that the Manipulator tip (tool mounting section) is at ± 5 V or less, even directly after the measuring operation according to Seiko Epson standards.

If you need any other detailed information, please contact the supplier.

Also, please check the amount of charge on any hand, wiring, or the like that you will attach to the robot on your own before use.

*2: The IP (International Protection) rating for Manipulators with protected-models is an international standard indicating the degree of protection against dust and water.

Model	Protection Class	
GX10-B/GX10-C/GX20-B/GX20-C***P*	Dust protection level: 6	No ingress of dust
	Water protection level: 5	Water which is directed against the enclosure from any direction as a jet shall not have any harmful effects or impair performance.

*3: When PTP statements are used

The maximum operating speed in CP motion is 2,000 mm/s in the horizontal plane.

*4: When the center of gravity of the load matches the Joint #4 center position

When the center of gravity position is separated from the Joint #4 center position, set the parameter using the Inertia statement.

*5: When used in a low-temperature environment near the minimum temperature specified in the product specifications, or when the unit is idle for a long period of time during holidays or at night, a collision detection error or similar error may occur immediately after the start of operation due to high resistance in the drive unit.

In such cases, warm-up operation for about 10 minutes is recommended.

*6: The conditions at measurement are as follows.

- Manipulator operating conditions:
Rated load, four-joint simultaneous operation, maximum speed, maximum acceleration/deceleration
- Measurement locations
Manipulator rear side, 1,000 mm away from work envelope, and 50 mm above base mounting surface

*7: The Accel setting of "100" is the optimum setting that balances acceleration/deceleration and vibration during positioning.

*8: Note the following points when wiring the movable M/C cable.

- Install the cable not to apply a load to the connector.
- Bend the cable at the minimum bending radius of the movable part or more. The bending radius (a) and dimensions are shown in the figure below.

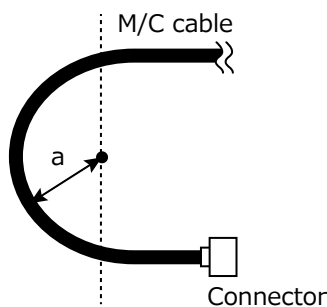

6.2 Appendix B: Stopping Time and Stopping Distance at Emergency Stop

The stopping time and stopping distance at an emergency stop are shown in the graphs for each model.

The stopping time is the length of time corresponding to the "Stopping time" in the figure below. Be sure to confirm that a safe environment is provided where the robot will be installed and operated.

For models equipped with a safety board such as RC700-E, RC800-A, the stopping time and stopping distance when using the Safety Limited Speed (SLS), Safety Limited Position (SLP), and Soft Axis Limiting are equivalent to those of the emergency stop.

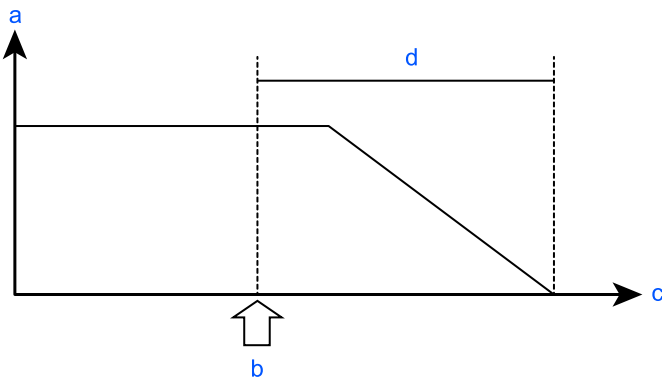

Symbol	Description
a	Motor speed
b	Emergency stop, Maximum Speed of SLS exceeded, monitoring areas and Joint Angle Limit of SLP exceeded, restricted range of Soft Axis Limiting exceeded
c	Time
d	Stopping time

Conditions

The stopping time and stopping distance depend on the parameters (setting values) that were set for the robot. These graphs show the times and distances for the following parameters.

- Accel: 100, 100
- Other settings: Default

Explanation of legend

The graphs are displayed for each Weight setting value (at 100%, approx. 66%, and approx. 33% of the maximum payload, and at the rated load).

- Horizontal axis: Arm speed (Speed setting)
- Vertical axis: Stopping time and stopping distance at each arm speed
- Time (sec): Stopping time (sec)
- Distance (deg): J1 and J2 stopping distance (degree)
- Distance (mm): J3 stopping distance

When single failures are taken into account, the following adjustments are used.

- Stopping distance and angle: Each axis reaches the mechanical stop
- Stopping time: Add 500 ms

6.2.1 GX4 Stopping Time and Stopping Distance at Emergency Stop

GX4-A/GX4-B/GX4-C25***: J1

Standard mode

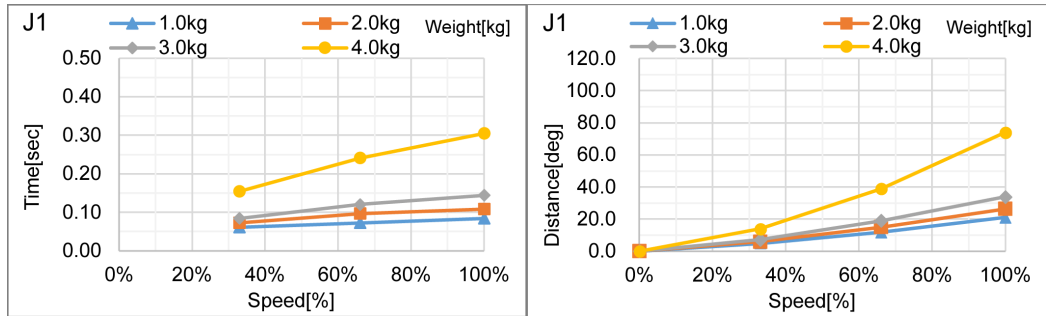

Boost mode

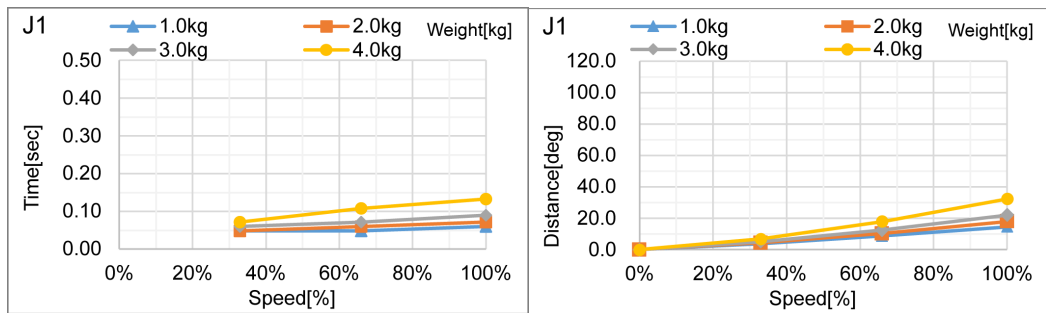

GX4-A/GX4-B/GX4-C25***: J2

Standard mode

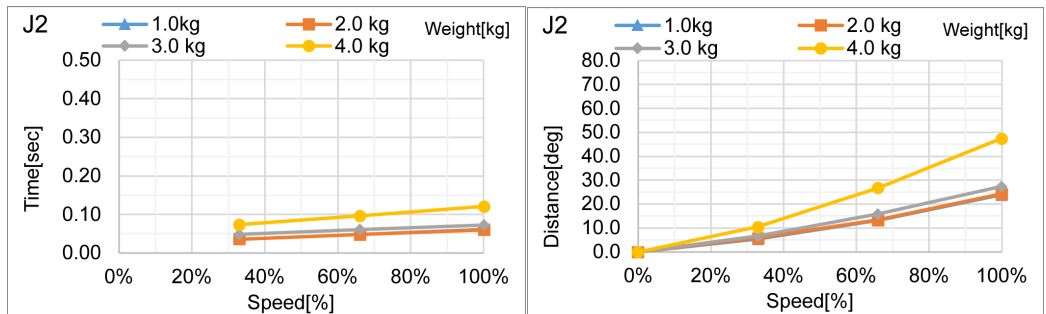

Boost mode

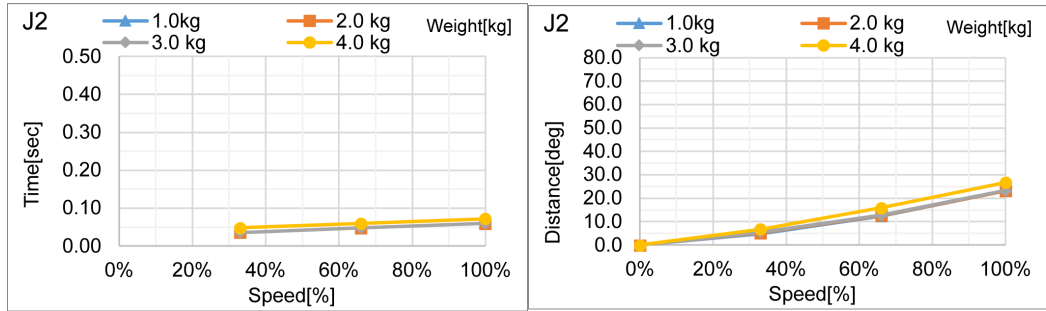

GX4-A/GX4-B/GX4-C25*: J3**

Standard mode

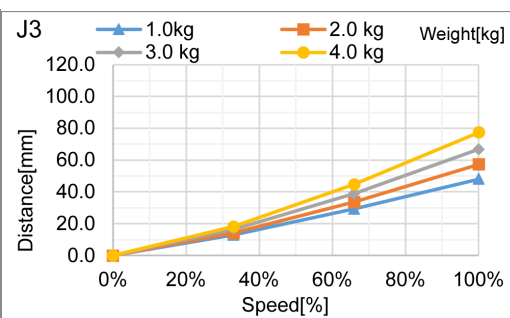
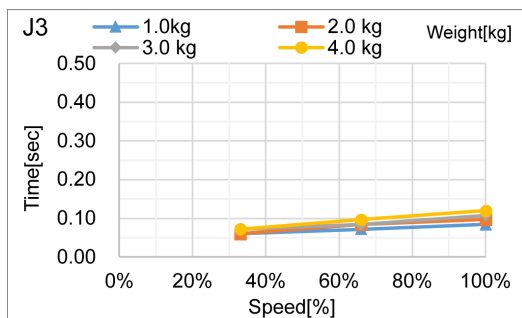

Boost mode

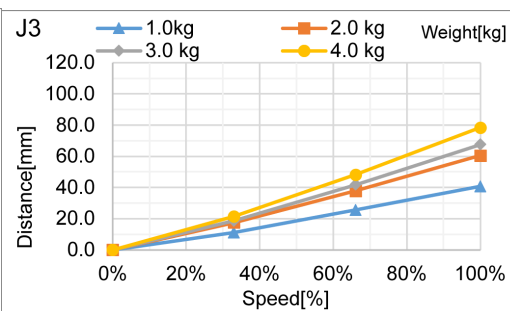
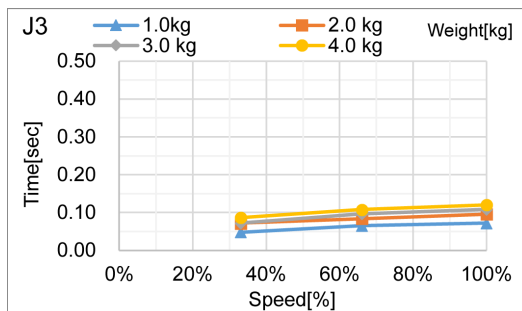

GX4-A/GX4-B/GX4-C30*: J1**

Standard mode

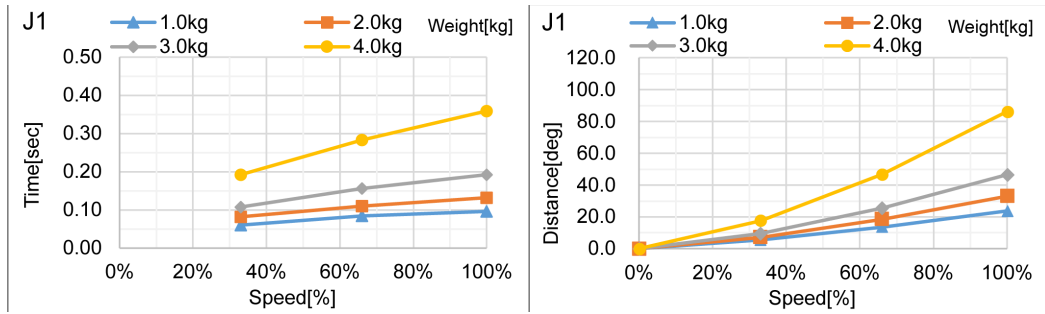

Boost mode

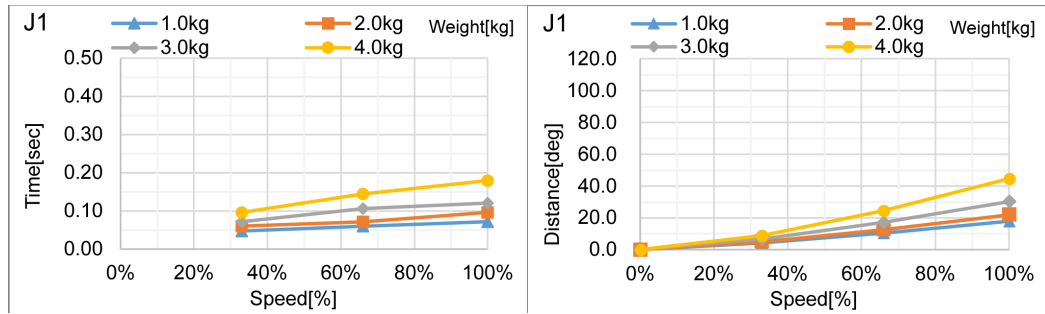

GX4-A/GX4-B/GX4-C30*: J2**

Standard mode

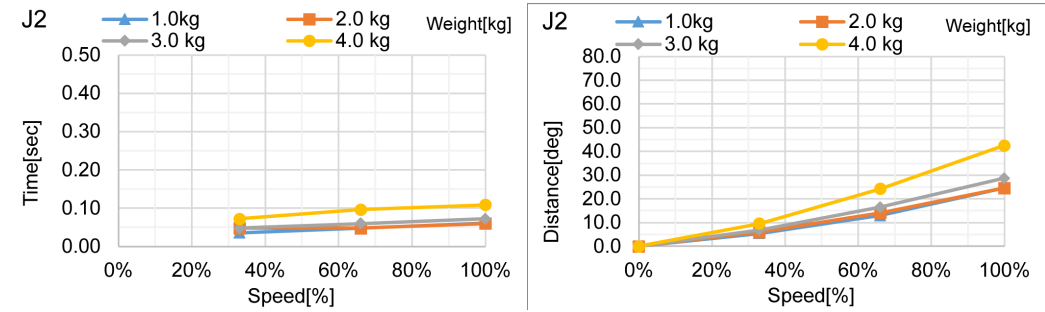

Boost mode

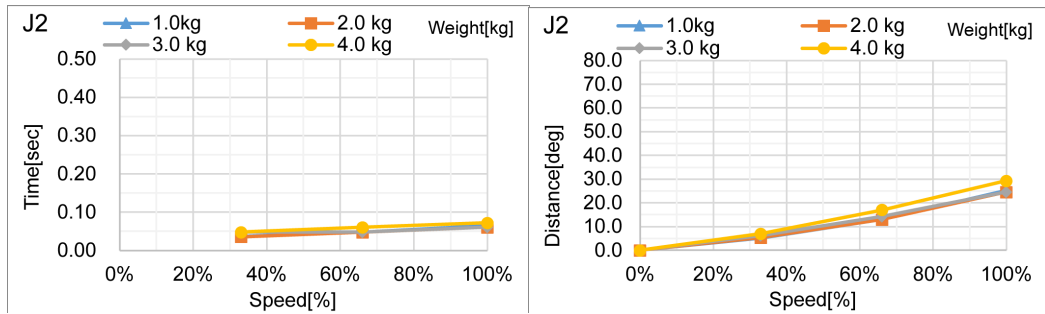

GX4-A/GX4-B/GX4-C30*: J3**

Standard mode

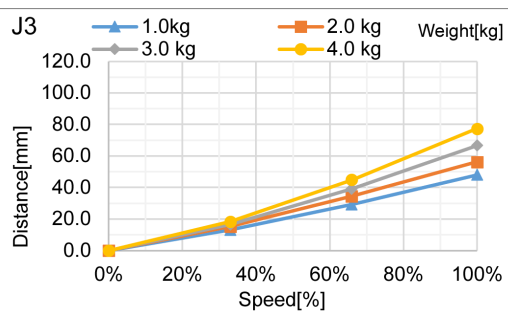
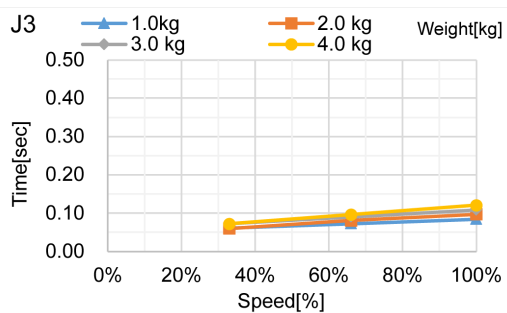

Boost mode

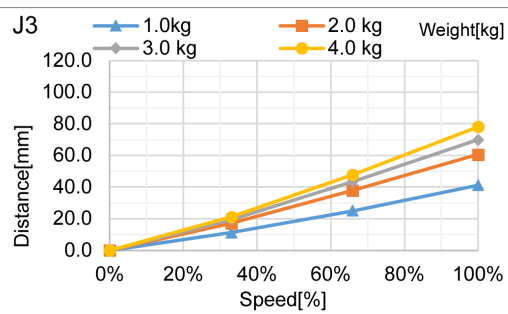
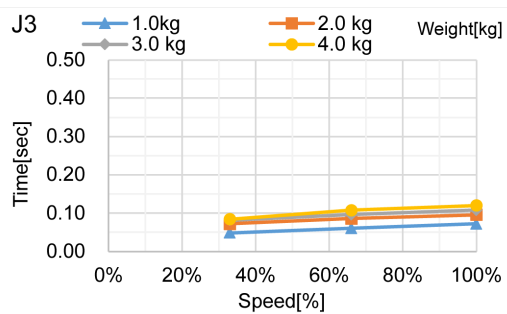

GX4-A/GX4-B/GX4-C35*: J1**

Standard mode

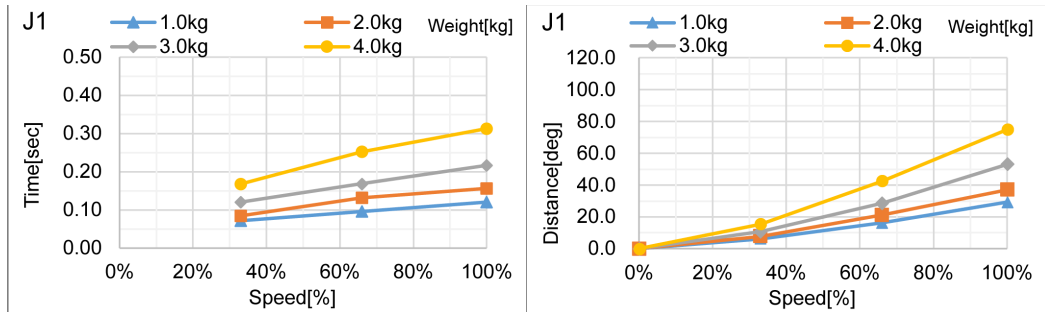

Boost mode

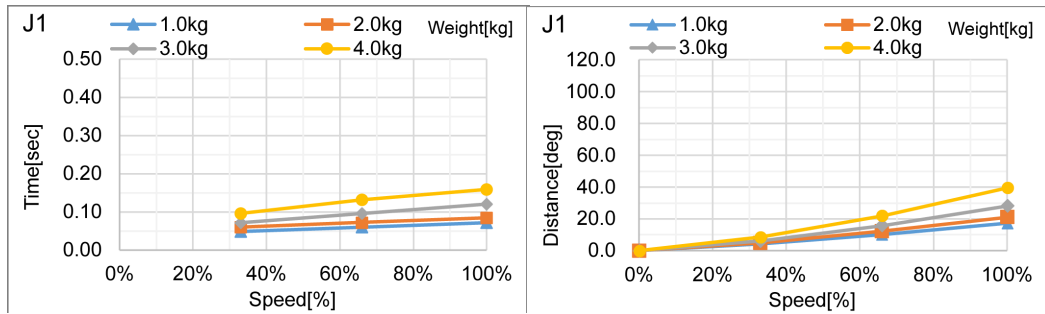

GX4-A/GX4-B/GX4-C35*: J2**

Standard mode

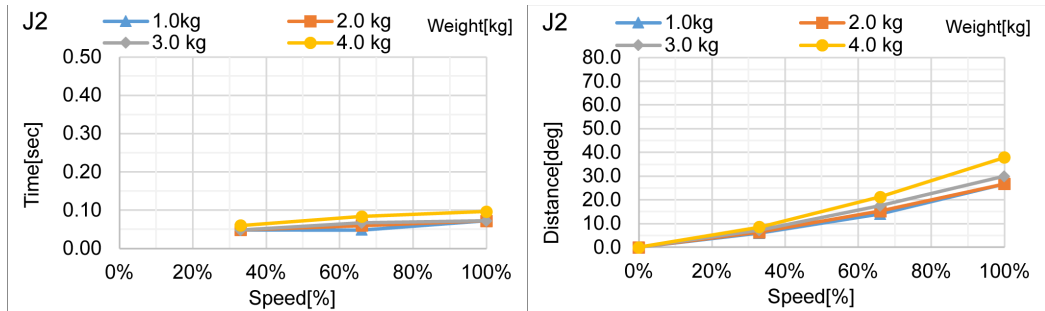

Boost mode

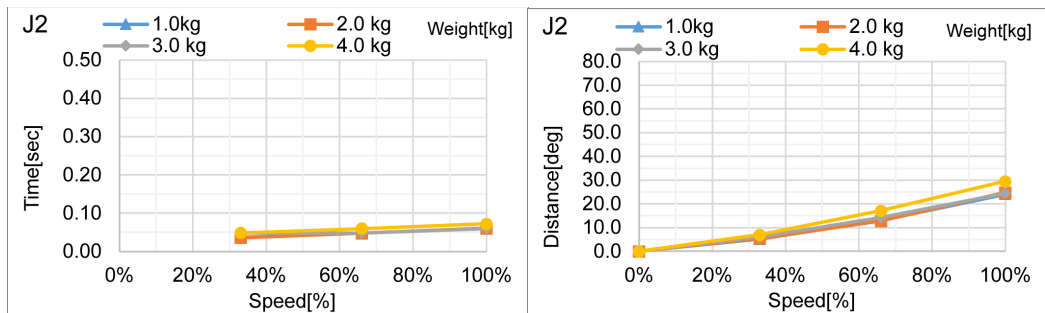

GX4-A/GX4-B/GX4-C35*: J3**

Standard mode

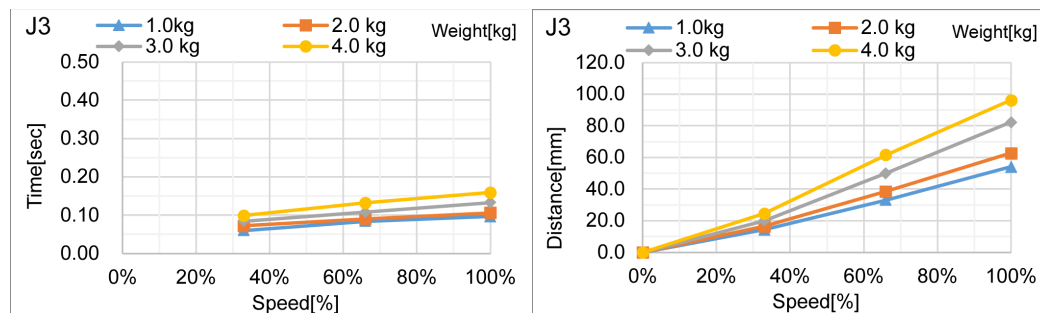

Boost mode

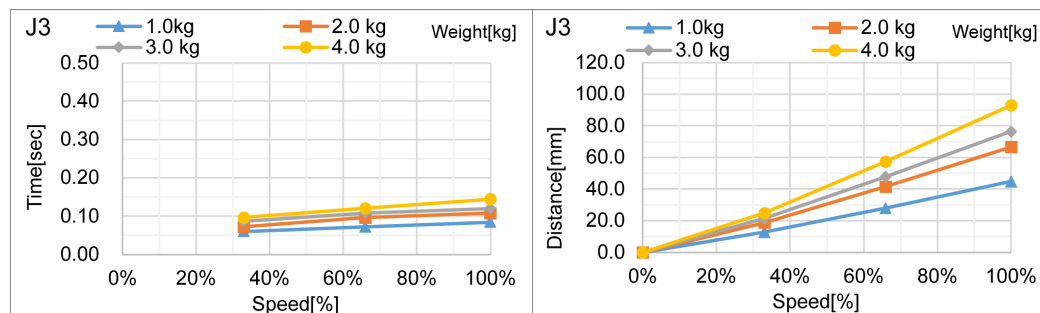

6.2.2 GX8 Stopping Time and Stopping Distance at Emergency Stop

GX8-A/GX8-B/GX8-C45***: J1

Standard mode

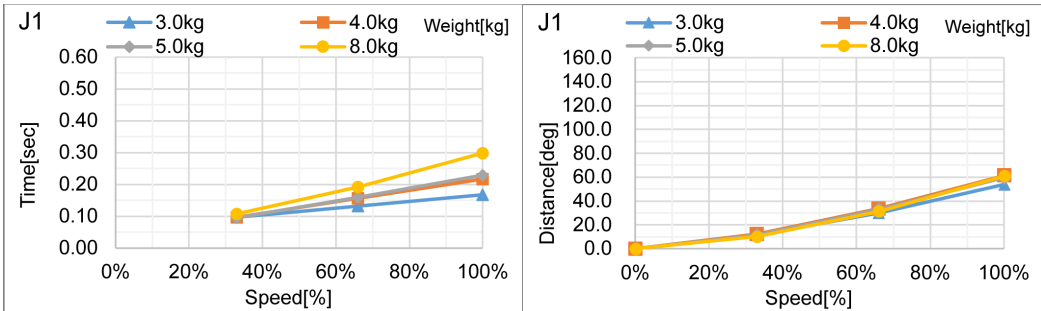

Boost mode

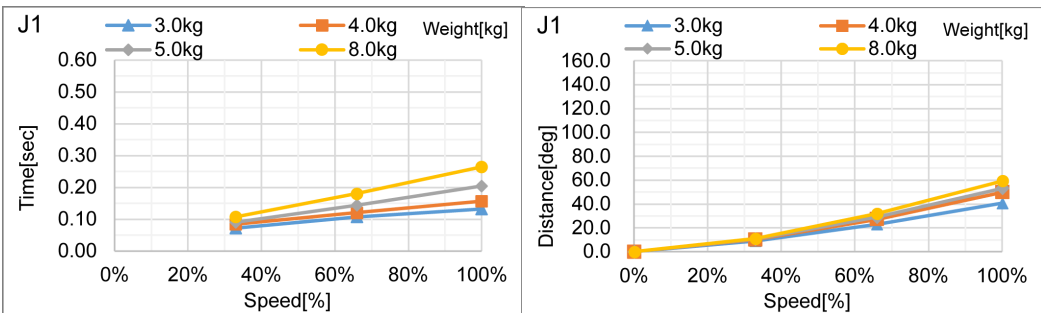

GX8-A/GX8-B/GX8-C45***: J2

Standard mode

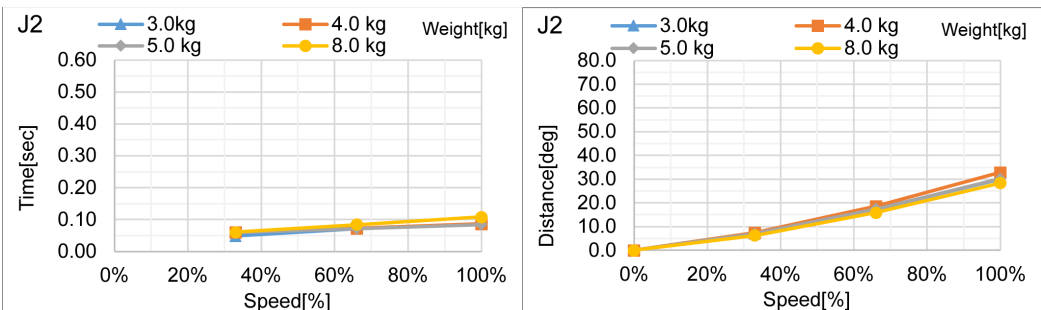

Boost mode

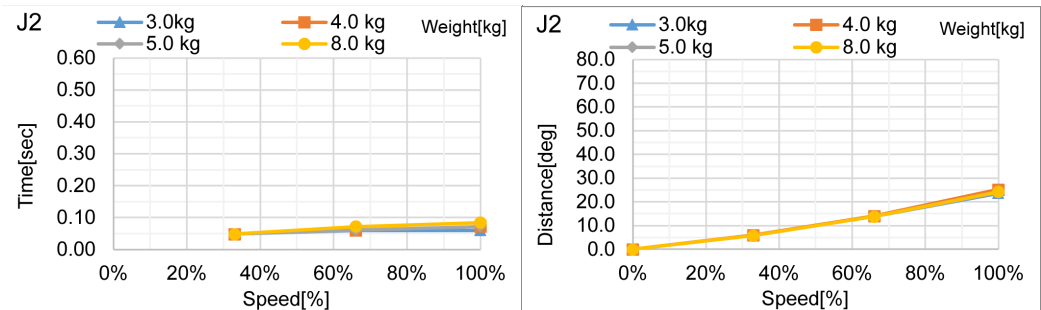

GX8-A/GX8-B/GX8-C45*: J3**

Standard mode

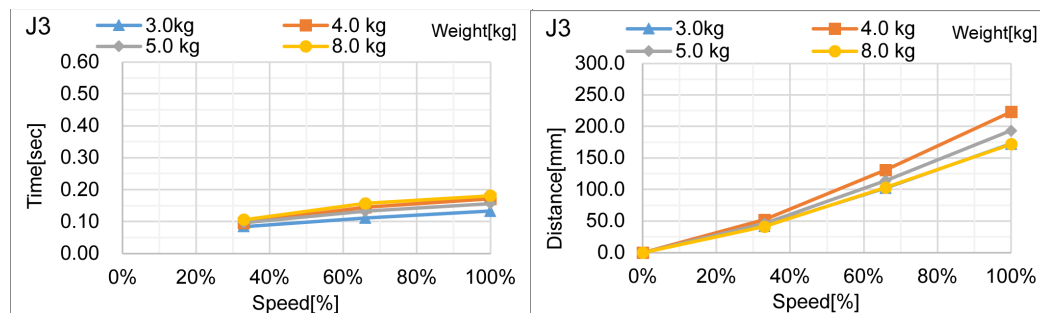

Boost mode

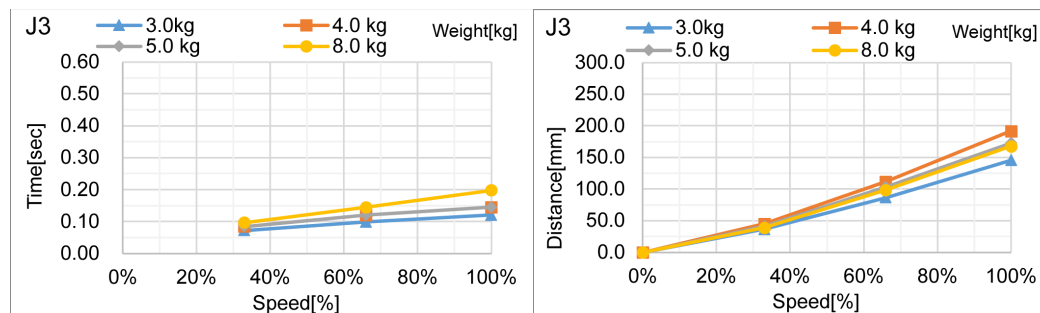

GX8-A/GX8-B/GX8-C55*: J1**

Standard mode

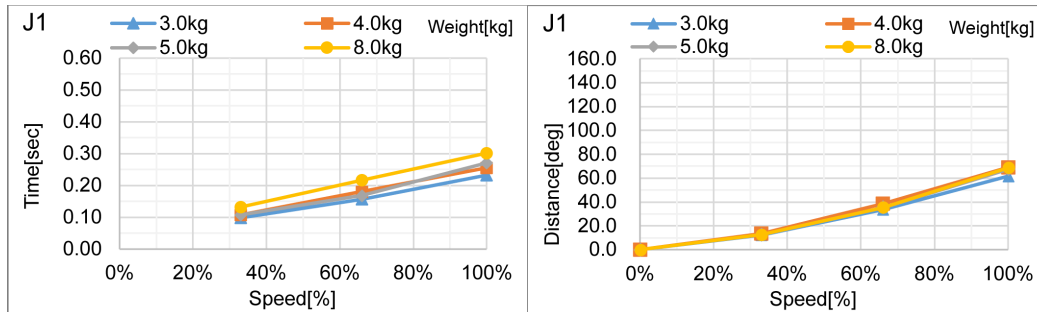

Boost mode

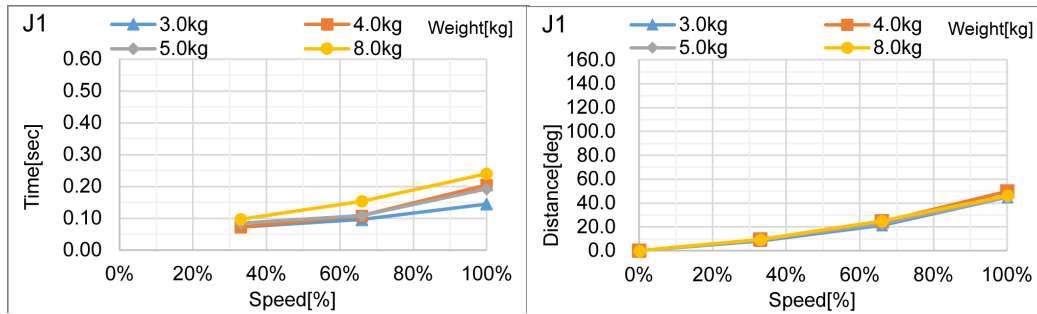

GX8-A/GX8-B/GX8-C55*: J2**

Standard mode

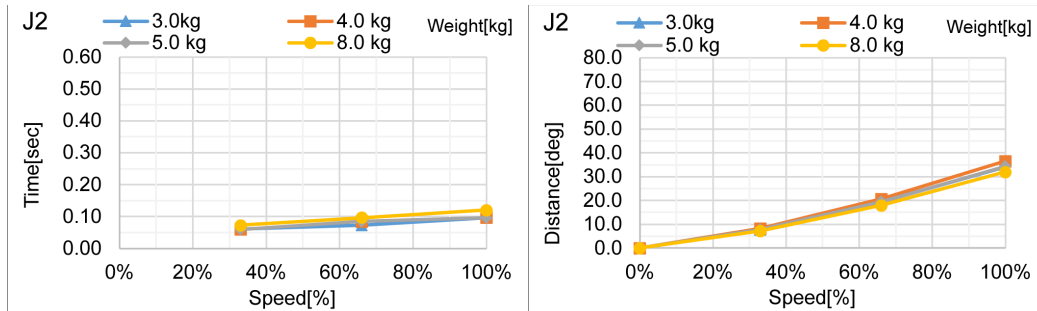

Boost mode

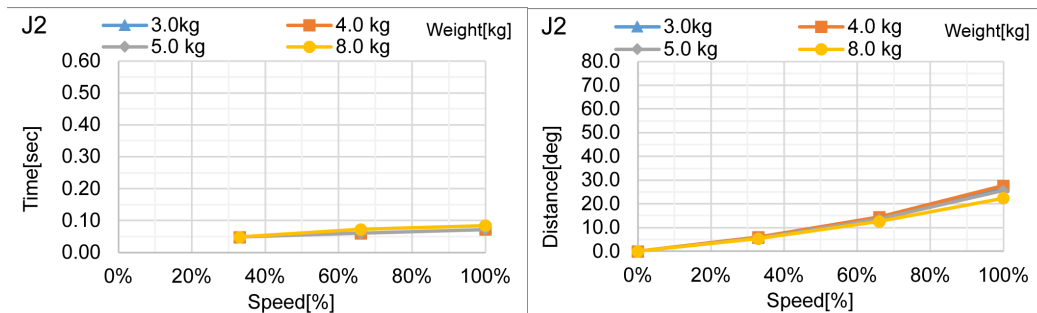

GX8-A/GX8-B/GX8-C55*: J3**

Standard mode

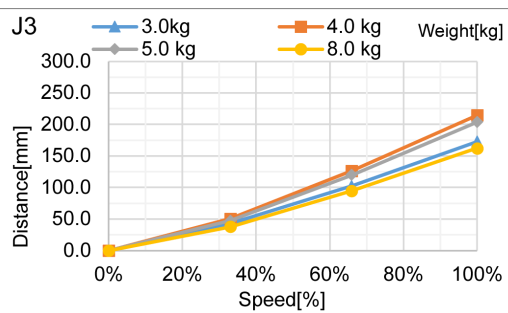
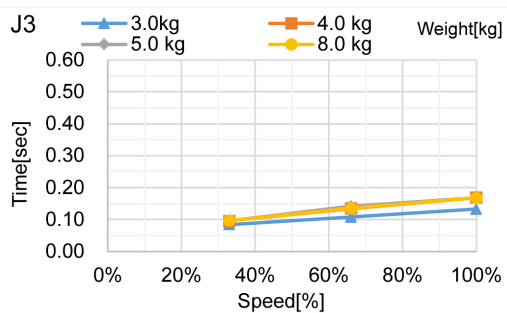

Boost mode

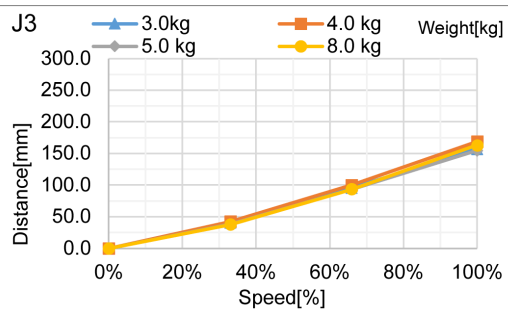
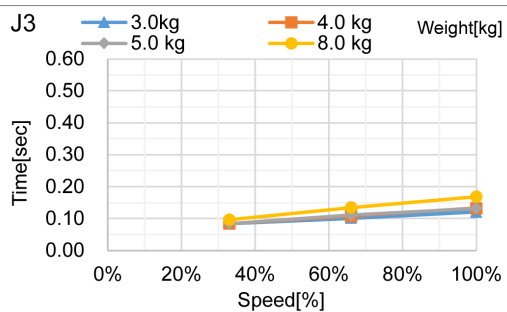

GX8-A/GX8-B/GX8-C65*: J1**

Standard mode

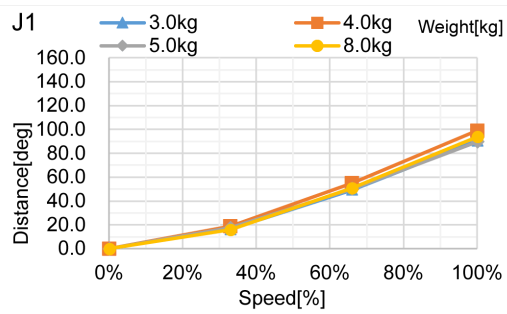
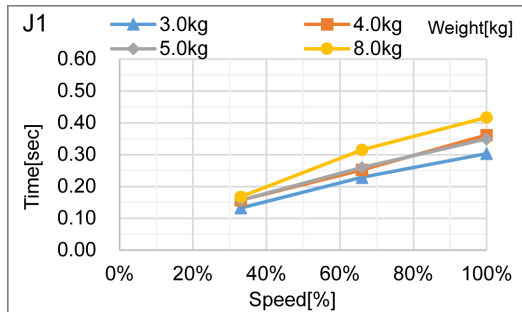

Boost mode

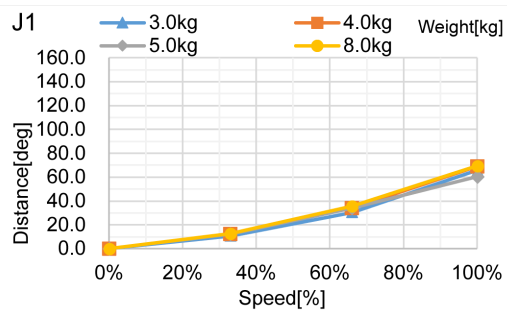
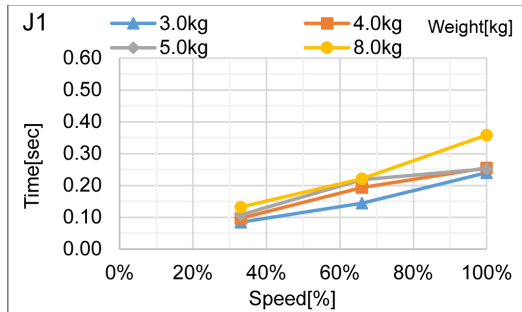

GX8-A/GX8-B/GX8-C65*: J2**

Standard mode

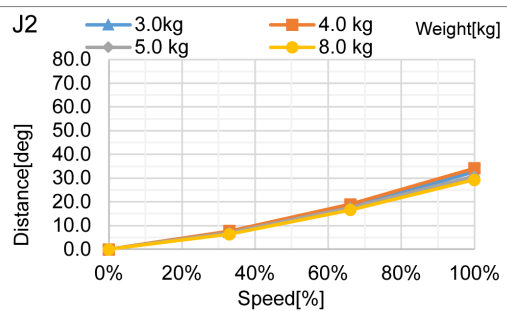
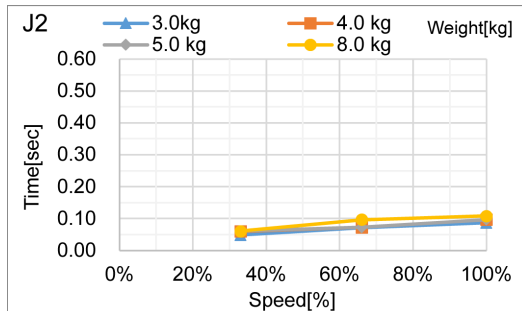

Boost mode

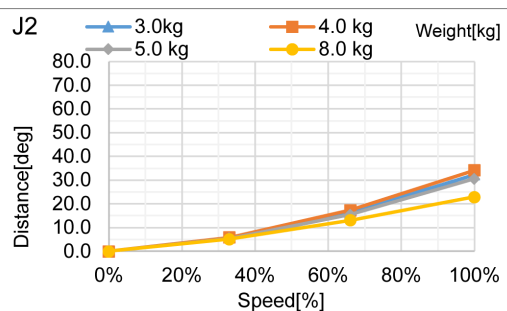
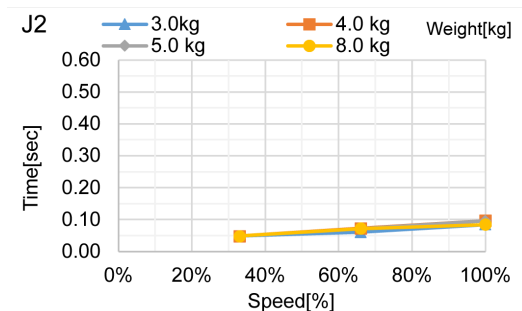

GX8-A/GX8-B/GX8-C65*: J3**

Standard mode

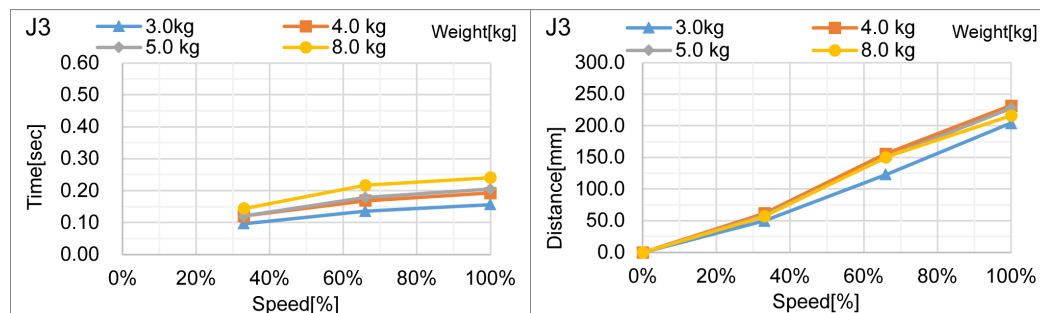

Boost mode

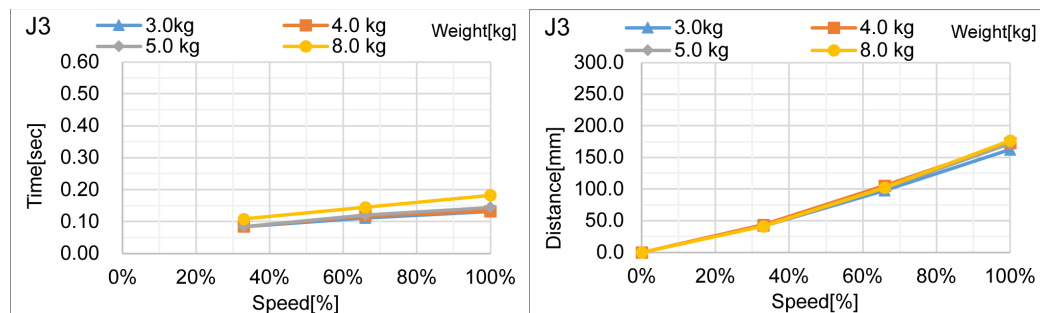

6.2.3 GX10 Stopping Time and Stopping Distance at Emergency Stop

GX10-B/GX10-C65***: J1

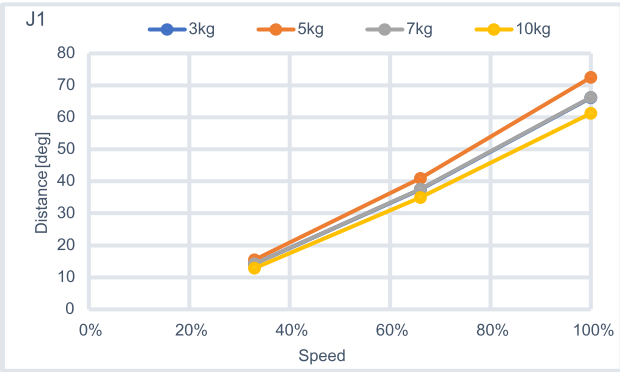
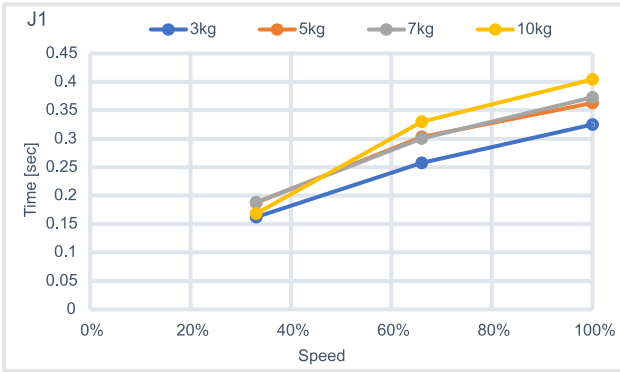

GX10-B/GX10-C65***: J2

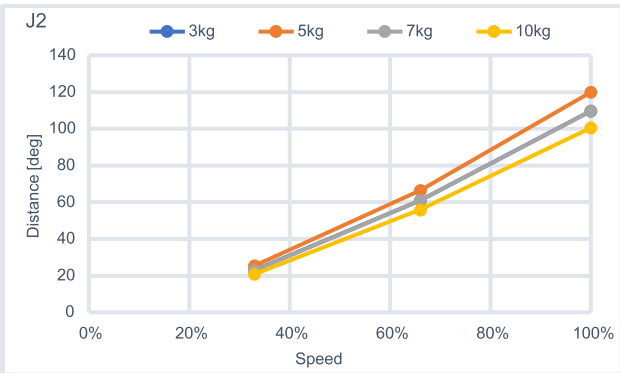
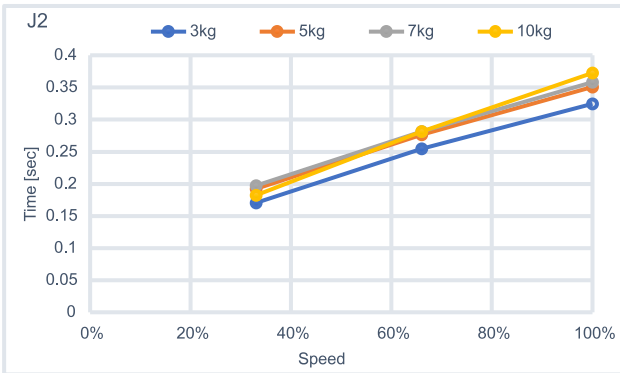

GX10-B/GX10-C65***: J3

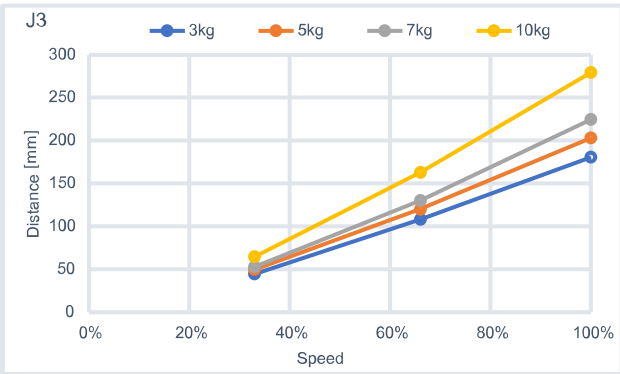
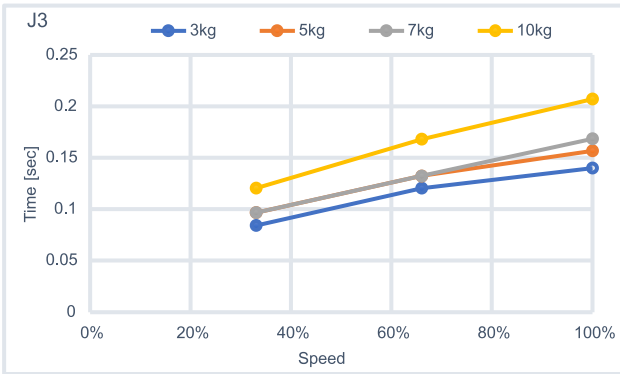

GX10-B/GX10-C85*: J1**

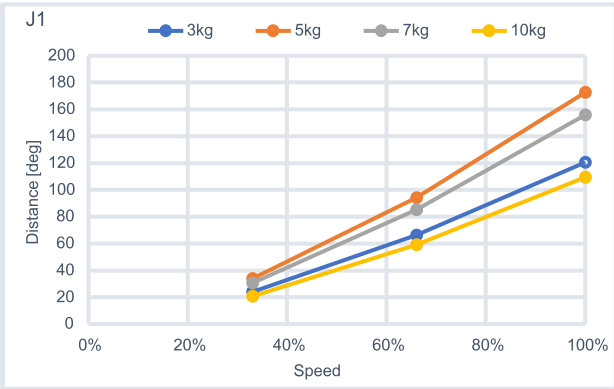
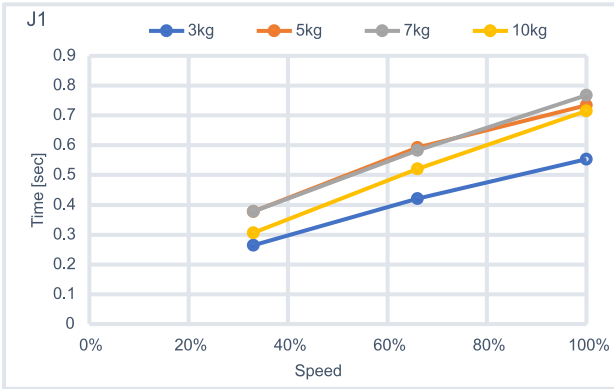

GX10-B/GX10-C85*: J2**

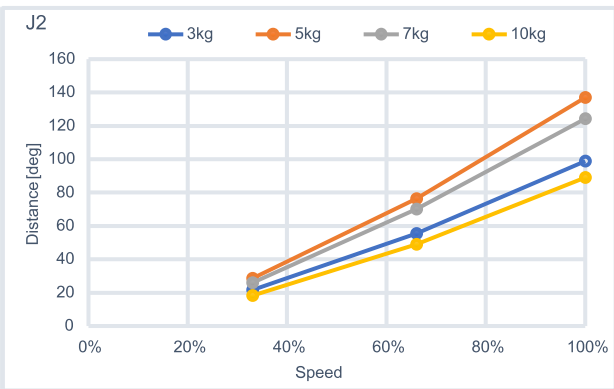
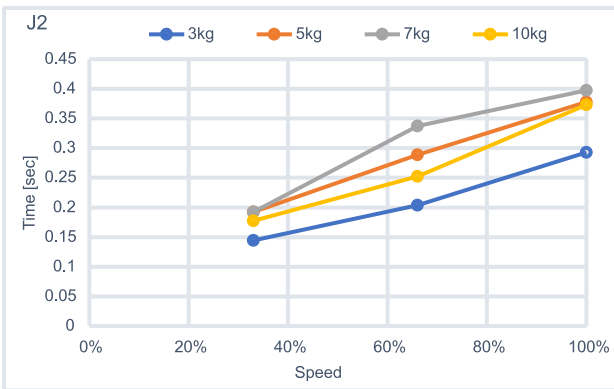

GX10-B/GX10-C85*: J3**

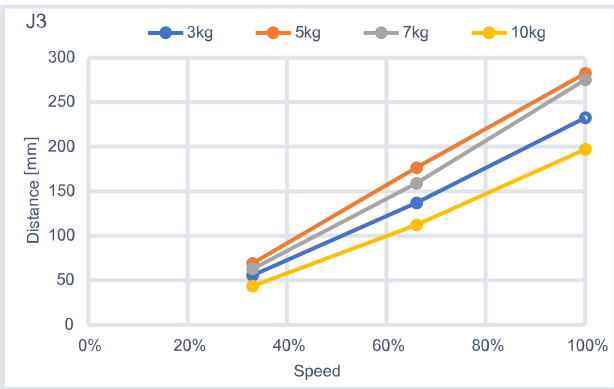
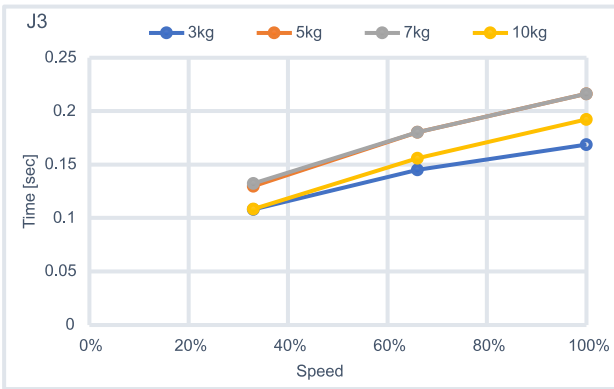

6.2.4 GX20 Stopping Time and Stopping Distance at Emergency Stop

GX20-B/GX20-C85***: J1

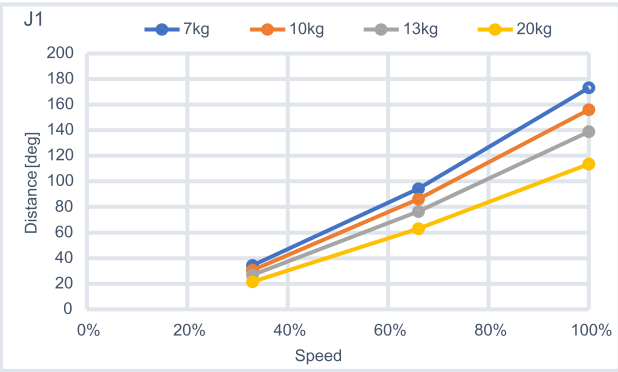
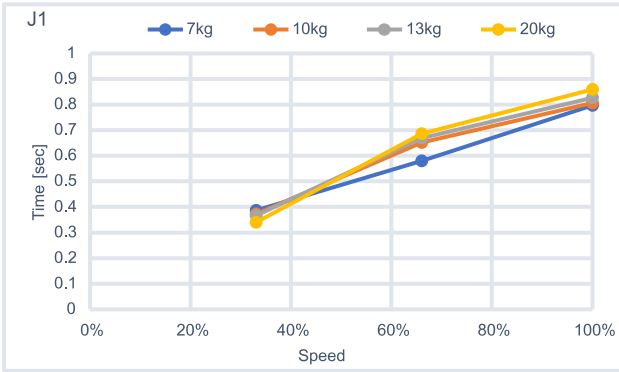

GX20-B/GX20-C85***: J2

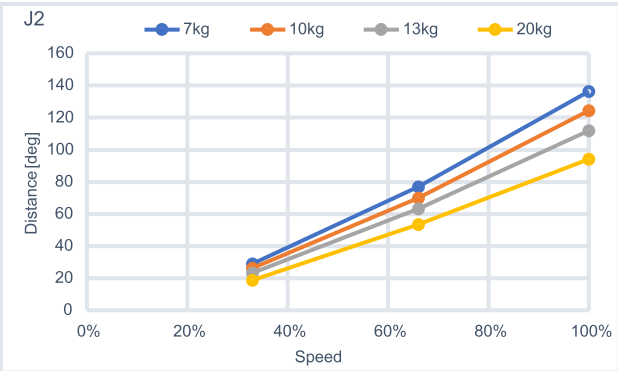
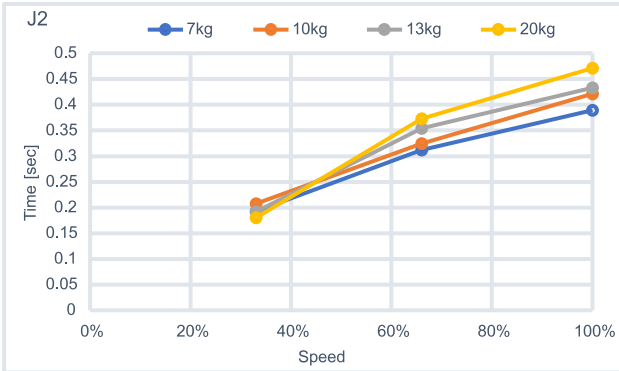

GX20-B/GX20-C85***: J3

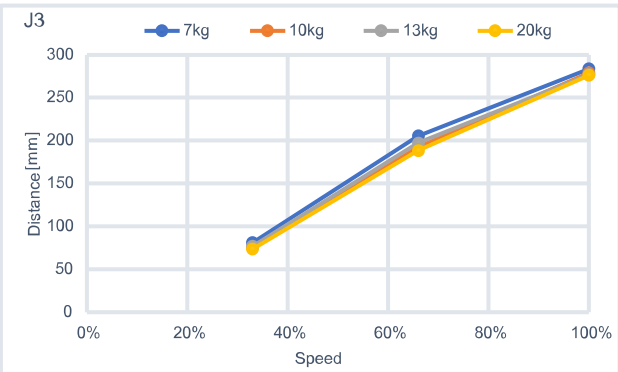
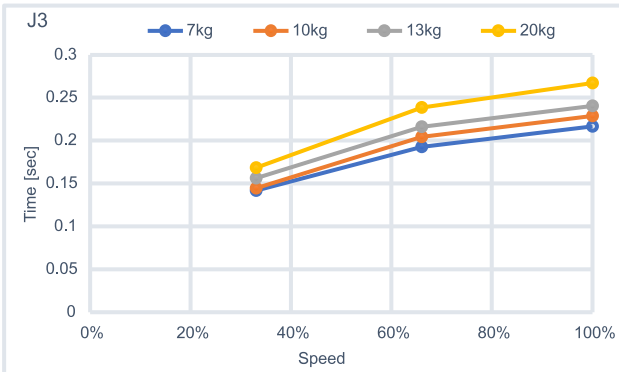

GX20-B/GX20-CA0*: J1**

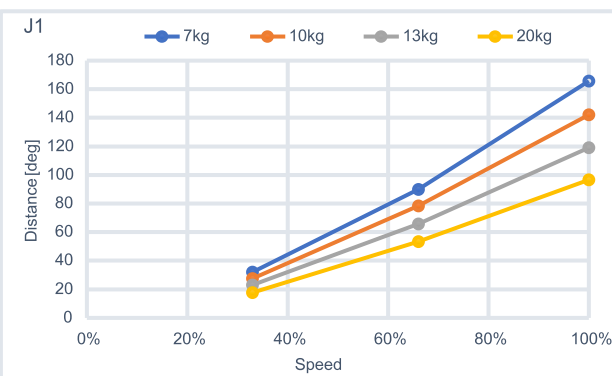
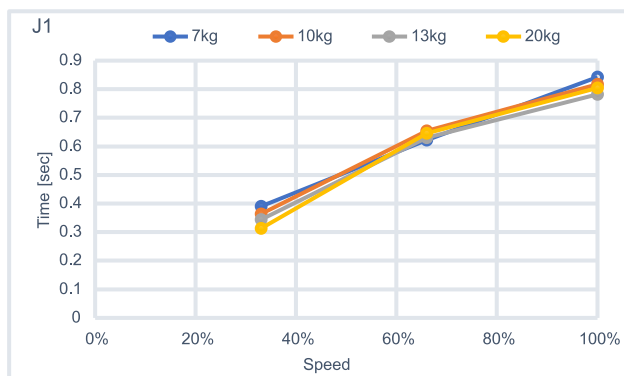

GX20-B/GX20-CA0*: J2**

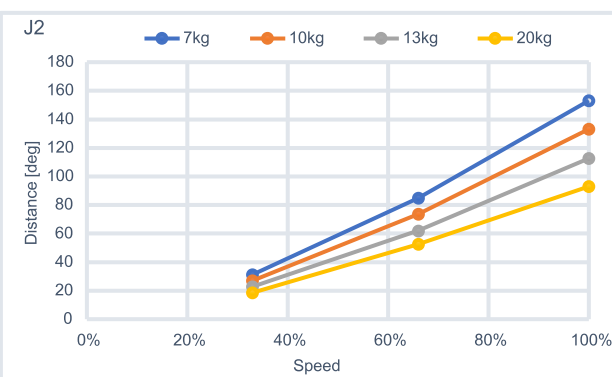
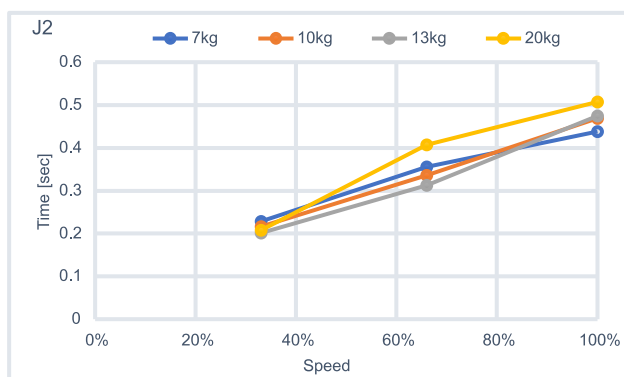

GX20-B/GX20-CA0*: J3**

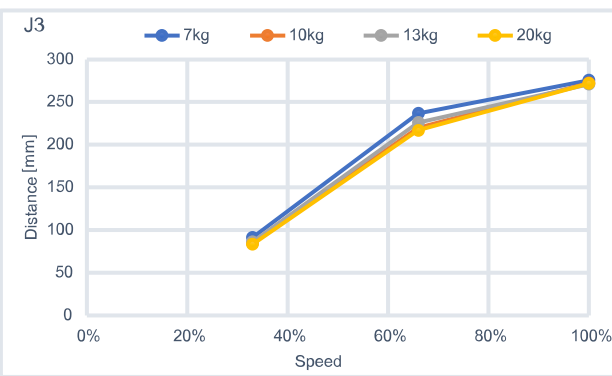
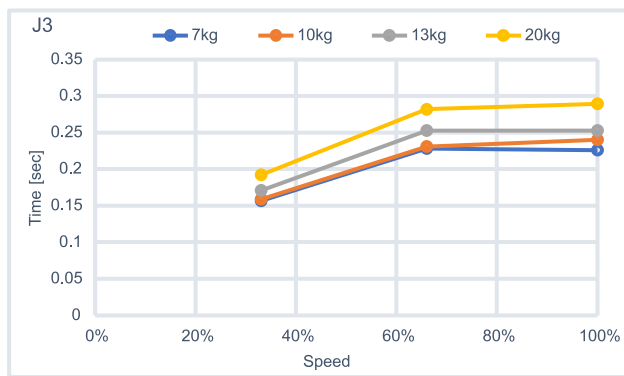

6.3 Appendix C: Stopping Time and Stopping Distance When Safeguard is Open

The stopping time and stopping distance when the safeguard is opened are shown in the graphs for each model.

The stopping time is the length of time corresponding to the "Stopping time" in the figure below. Be sure to confirm that a safe environment is provided where the robot will be installed and operated.

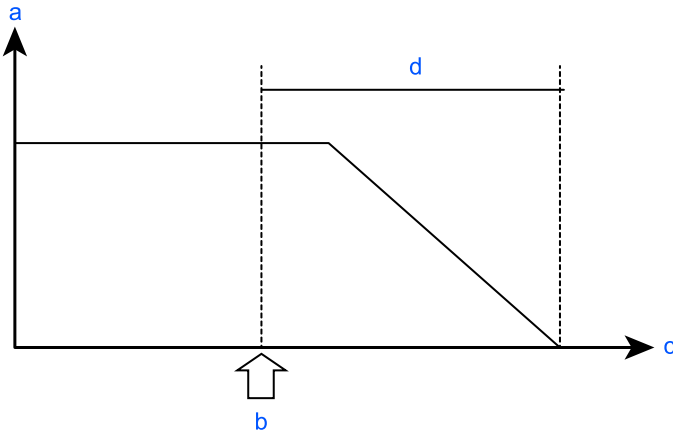

Symbol	Description
a	Motor speed
b	Safeguard open
c	Time
d	Stopping time

Conditions

The stopping time and stopping distance depend on the parameters (setting values) that were set for the robot. These graphs show the times and distances for the following parameters.

- Accel: 100, 100
- Other settings: Default

Explanation of legend

The graphs are displayed for each Weight setting value (at 100%, approx. 66%, and approx. 33% of the maximum payload, and at the rated load).

- Horizontal axis: Arm speed (Speed setting)
- Vertical axis: Stopping time and stopping distance at each arm speed
- Time (sec): Stopping time (sec)
- Distance (deg): J1 and J2 stopping distance (degree)
- Distance (mm): J3 stopping distance

When single failures are taken into account, the following adjustments are used.

- Stopping distance and angle: Each axis reaches the mechanical stop
- Stopping time: Add 500 ms

6.3.1 GX4 Stopping Time and Stopping Distance When Safeguard is Open

GX4-A/GX4-B/GX4-C25***: J1

Standard mode

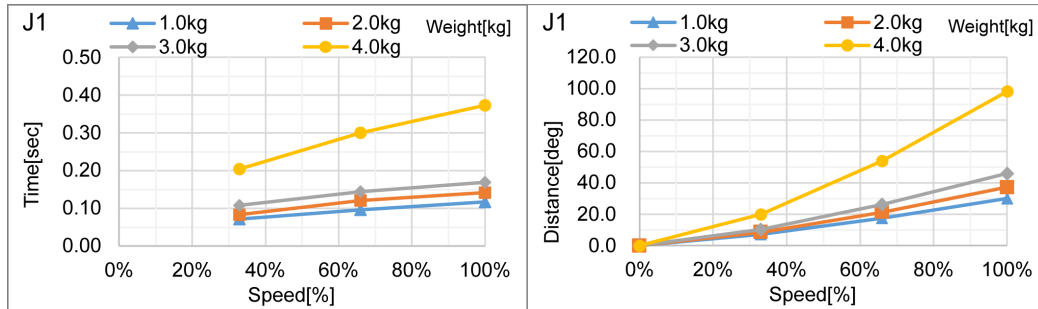

Boost mode

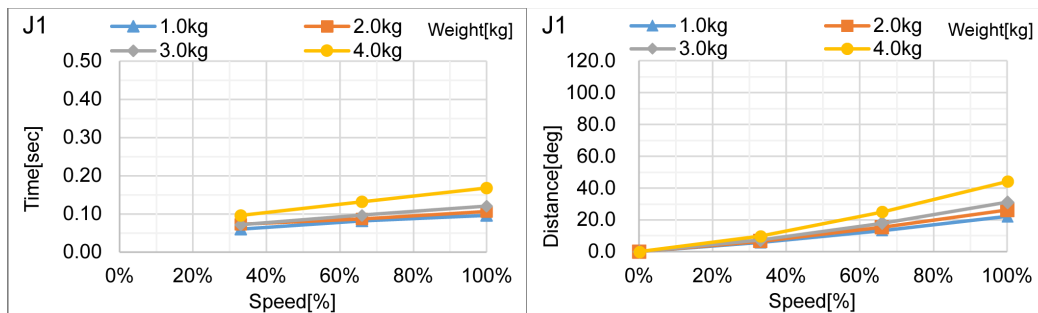

GX4-A/GX4-B/GX4-C25***: J2

Standard mode

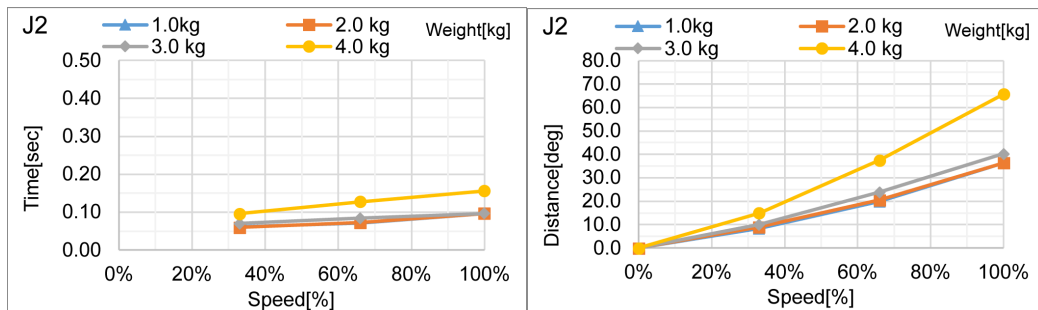

Boost mode

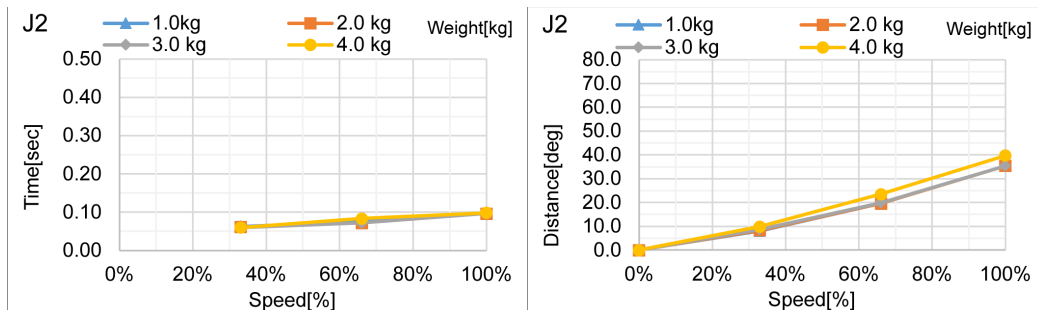

GX4-A/GX4-B/GX4-C25*: J3**

Standard mode

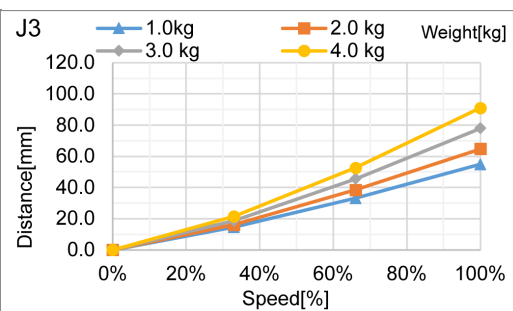
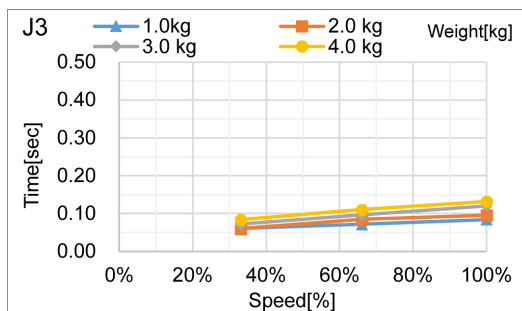

Boost mode

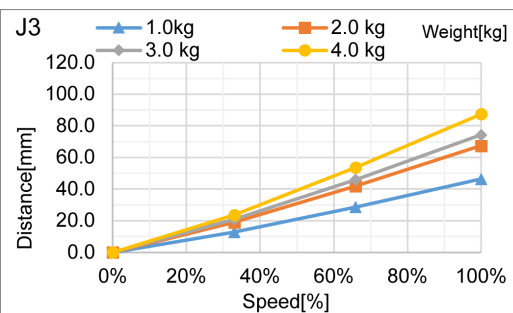
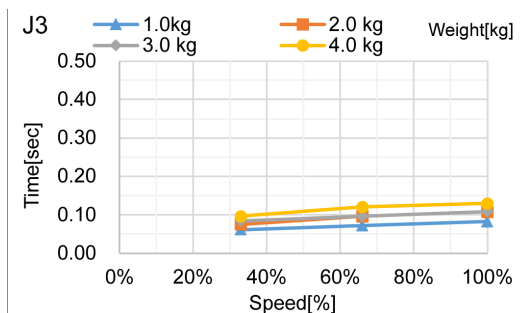

GX4-A/GX4-B/GX4-C30*: J1**

Standard mode

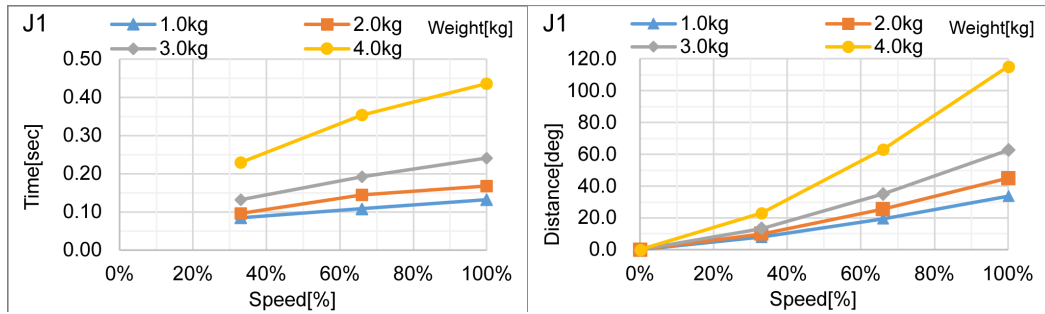

Boost mode

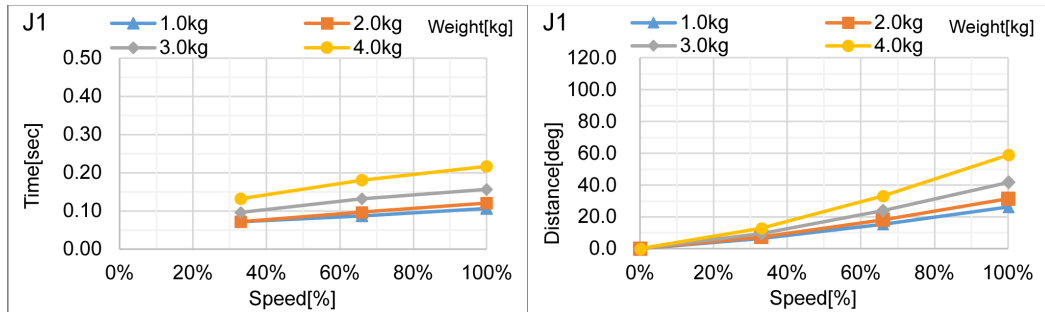

GX4-A/GX4-B/GX4-C30*: J2**

Standard mode

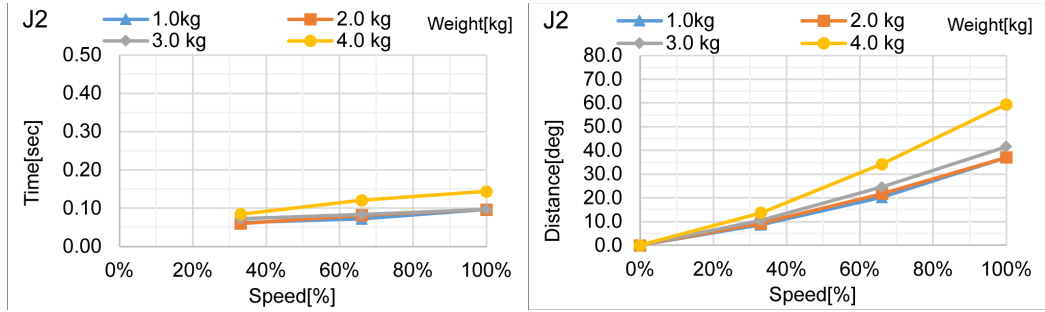

Boost mode

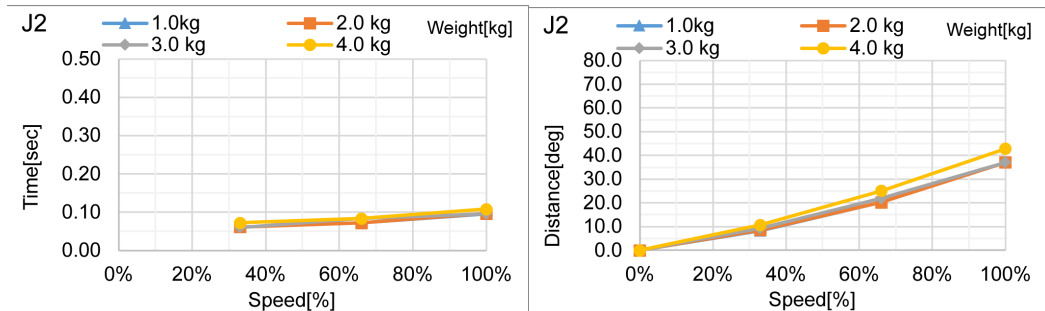

GX4-A/GX4-B/GX4-C30*: J3**

Standard mode

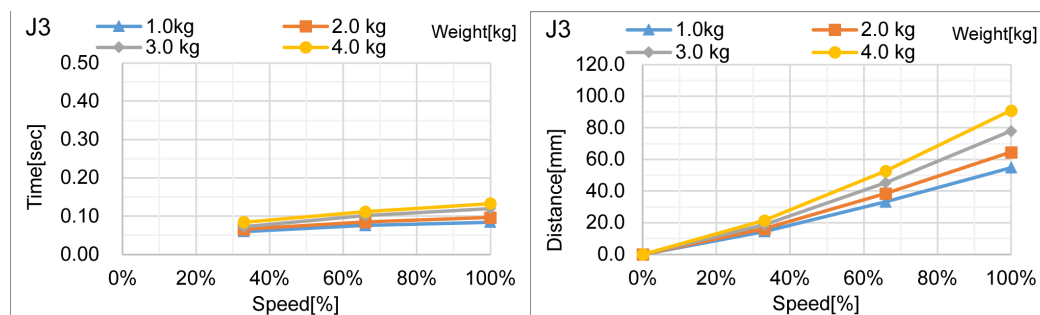

Boost mode

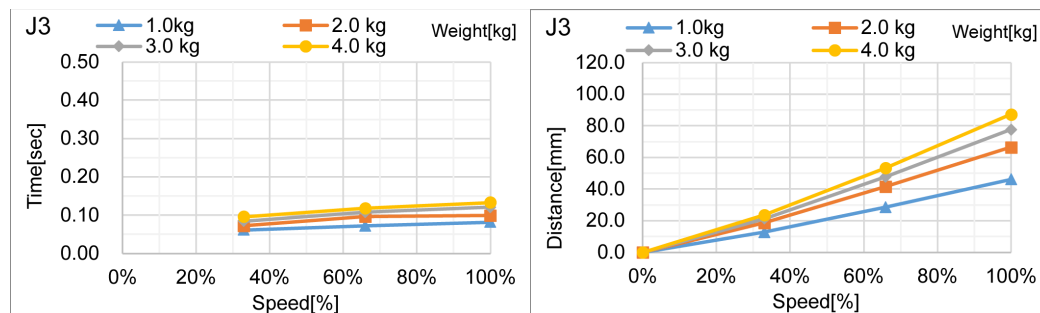

GX4-A/GX4-B/GX4-C35*: J1**

Standard mode

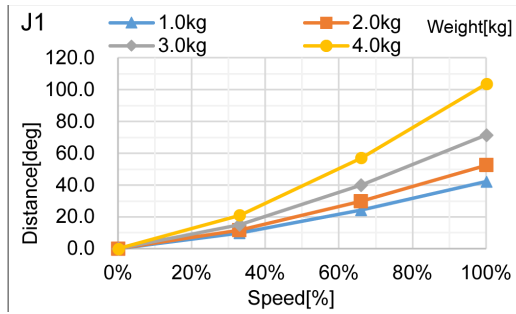
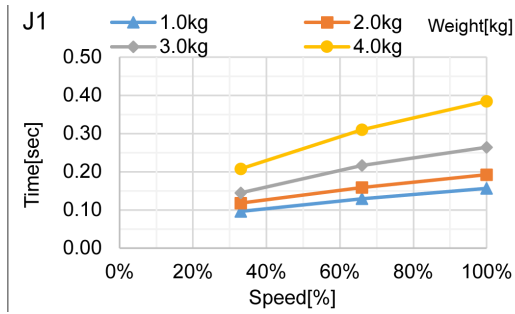

Boost mode

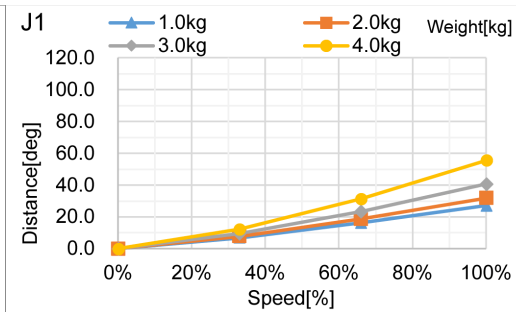
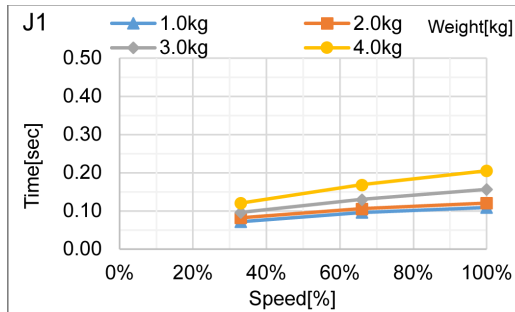

GX4-A/GX4-B/GX4-C35*: J2**

Standard mode

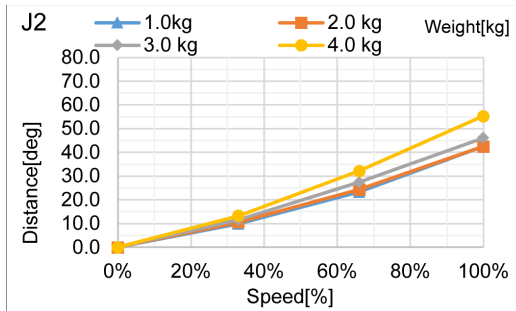
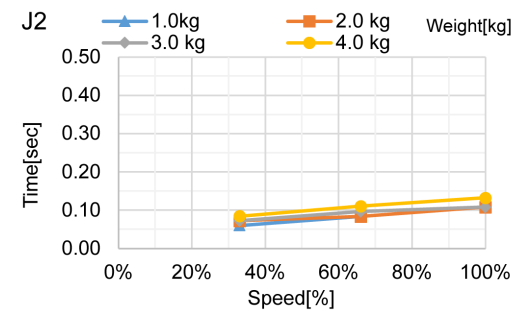

Boost mode

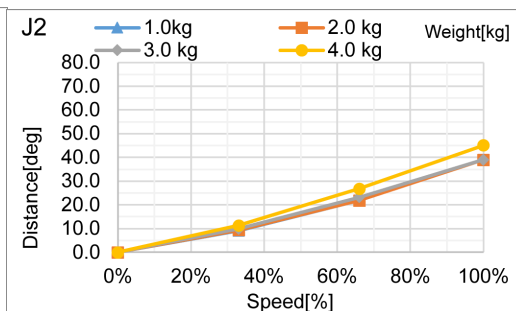
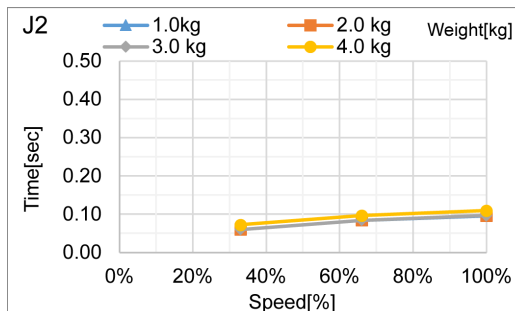

GX4-A/GX4-B/GX4-C35*: J3**

Standard mode

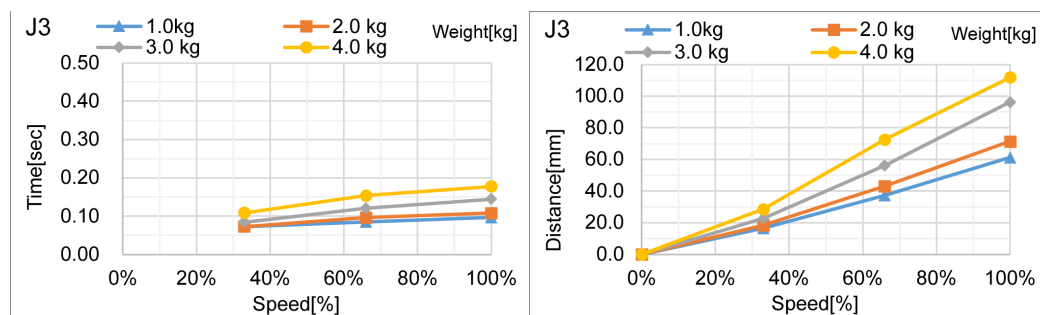

Boost mode

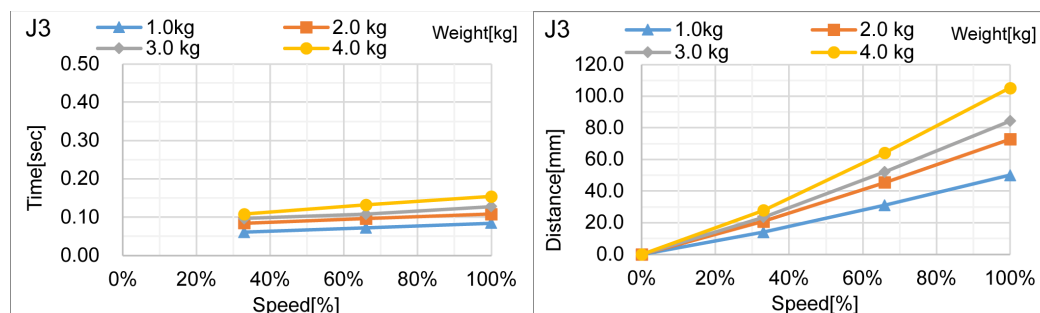

6.3.2 GX8 Stopping Time and Stopping Distance When Safeguard is Open

GX8-A/GX8-B/GX8-C45***: J1

Standard mode

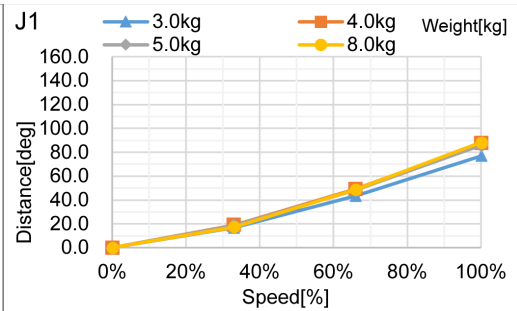
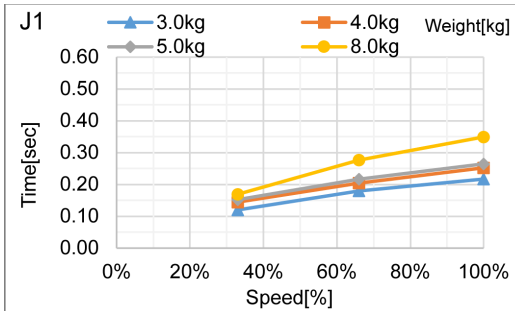

Boost mode

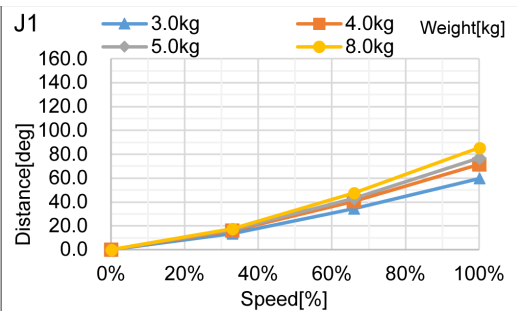
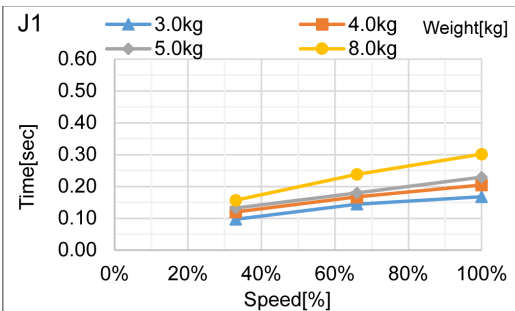

GX8-A/GX8-B/GX8-C45***: J2

Standard mode

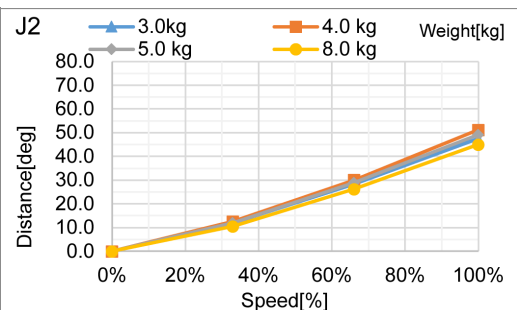
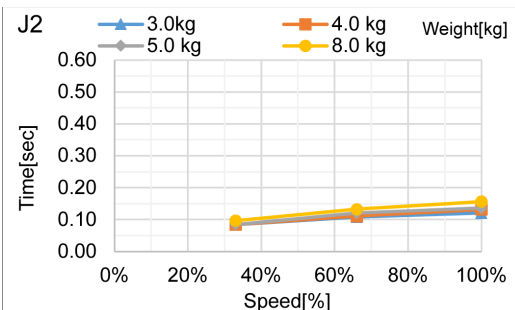

Boost mode

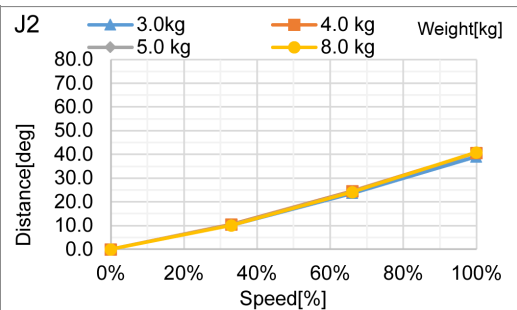
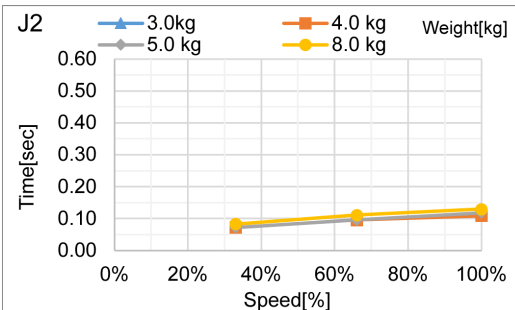

GX8-A/GX8-B/GX8-C45*: J3**

Standard mode

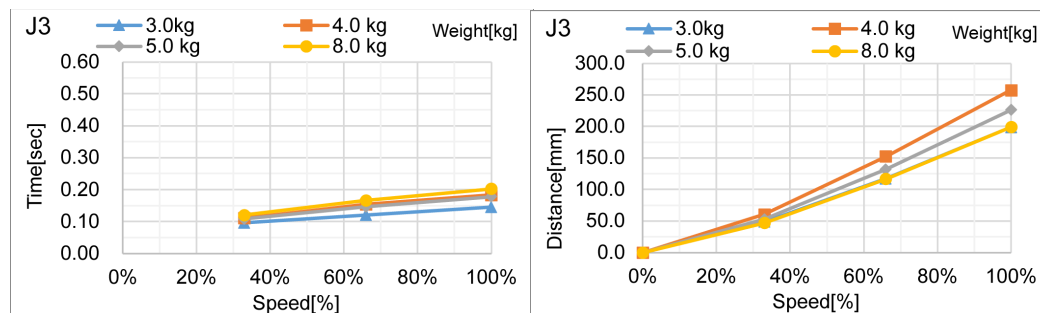

Boost mode

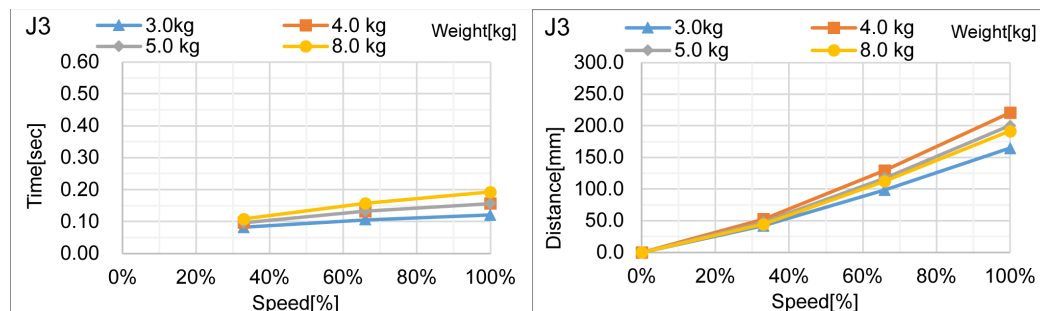

GX8-A/GX8-B/GX8-C55*: J1**

Standard mode

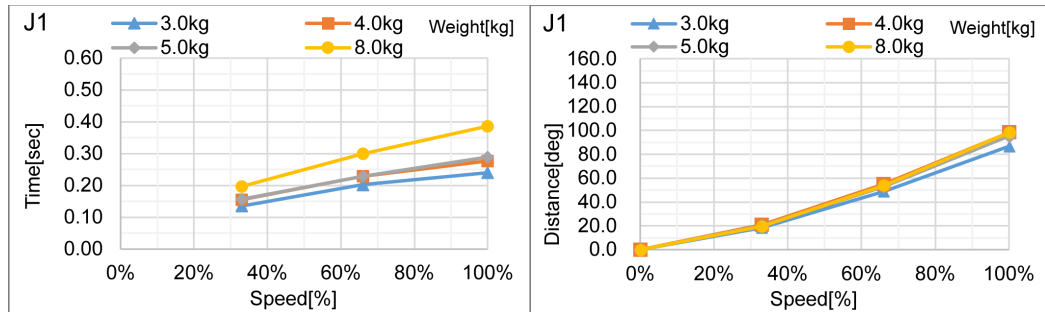

Boost mode

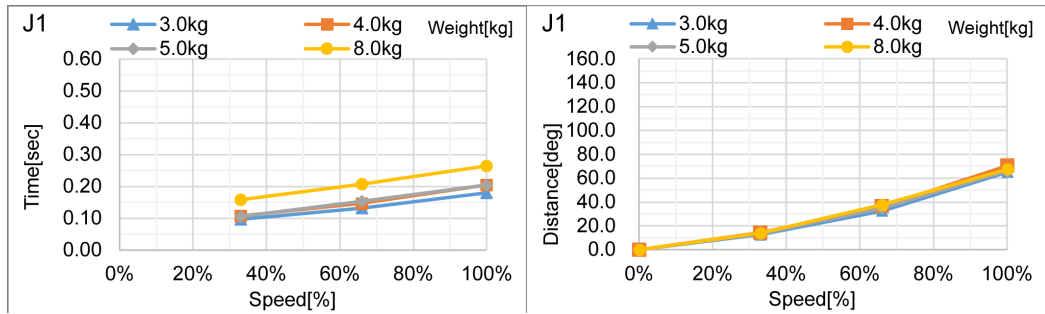

GX8-A/GX8-B/GX8-C55*: J2**

Standard mode

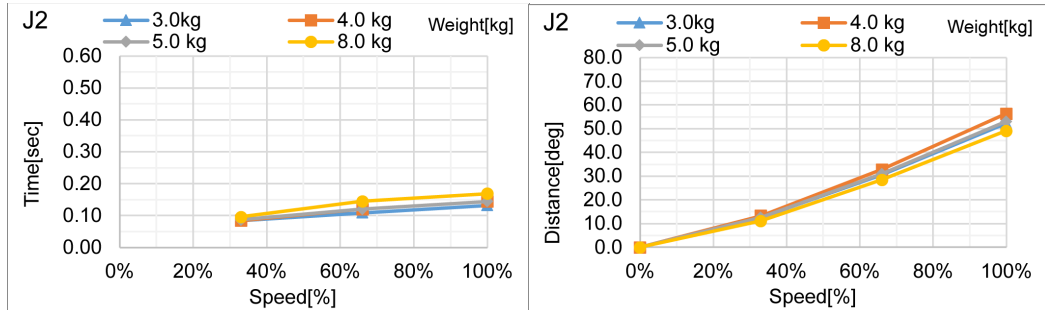

Boost mode

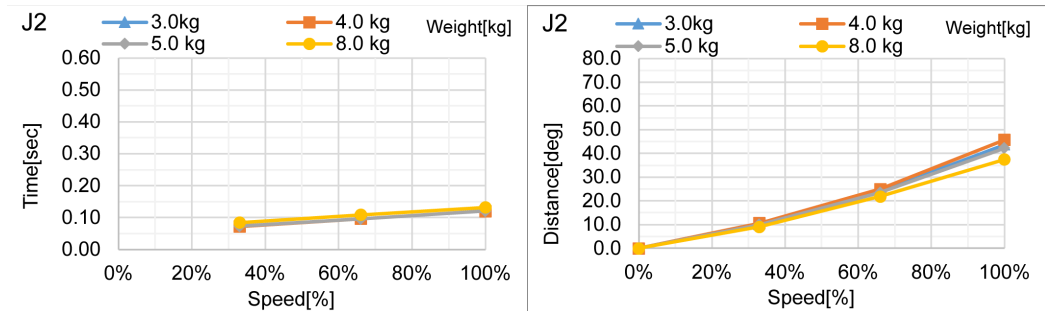

GX8-A/GX8-B/GX8-C55*: J3**

Standard mode

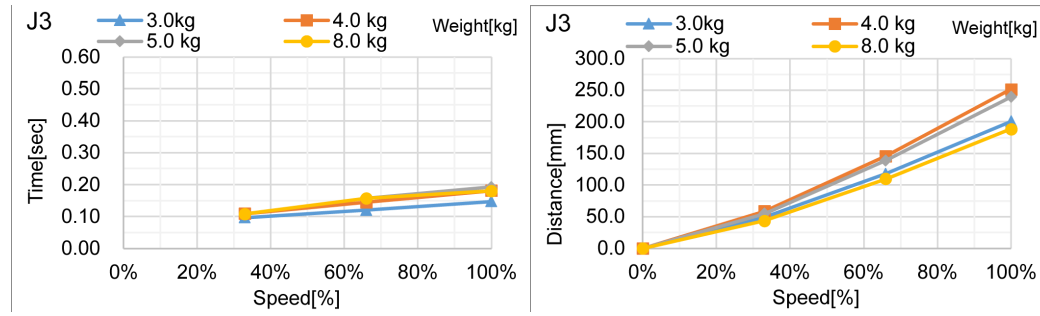

Boost mode

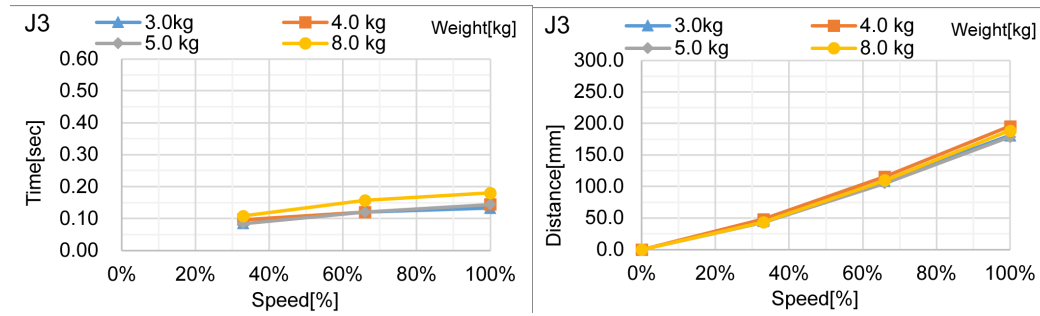

GX8-A/GX8-B/GX8-C65*: J1**

Standard mode

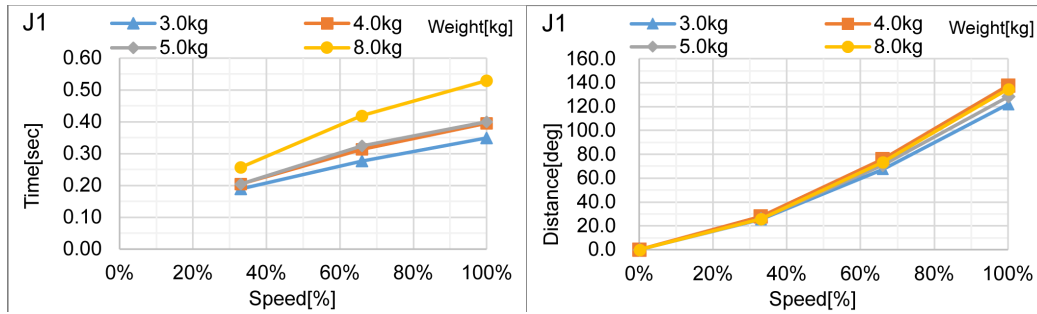

Boost mode

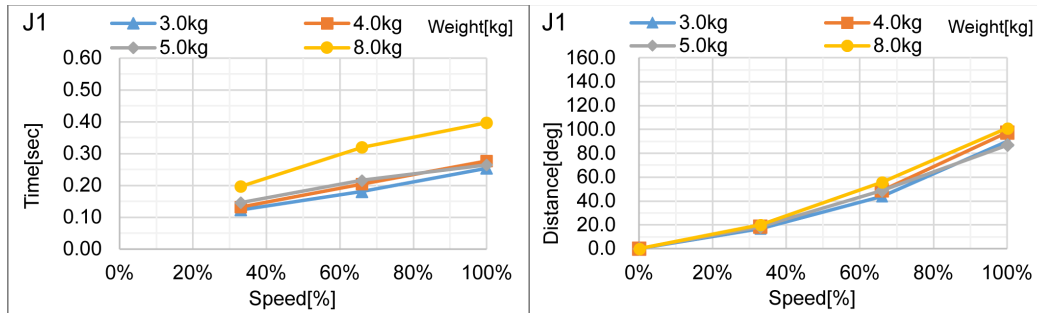

GX8-A/GX8-B/GX8-C65*: J2**

Standard mode

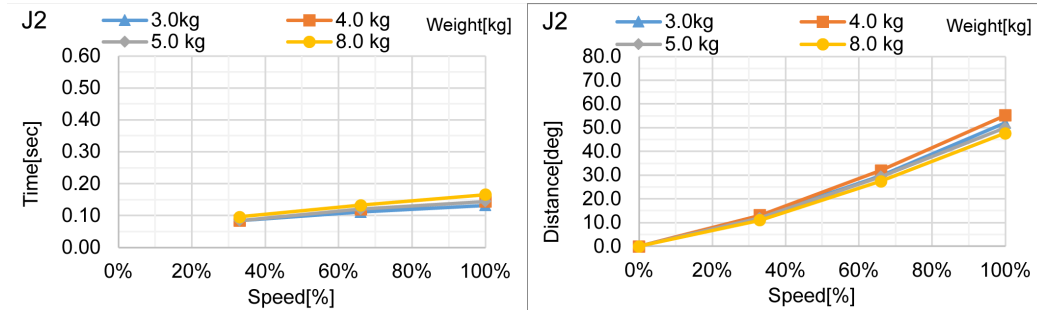

Boost mode

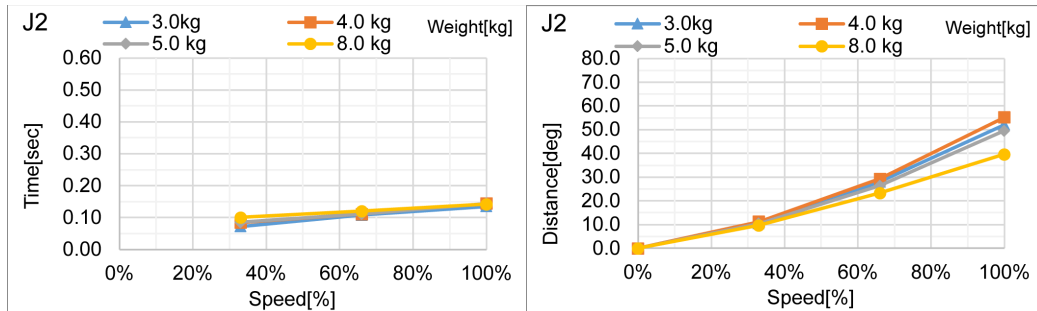

GX8-A/GX8-B/GX8-C65*: J3**

Standard mode

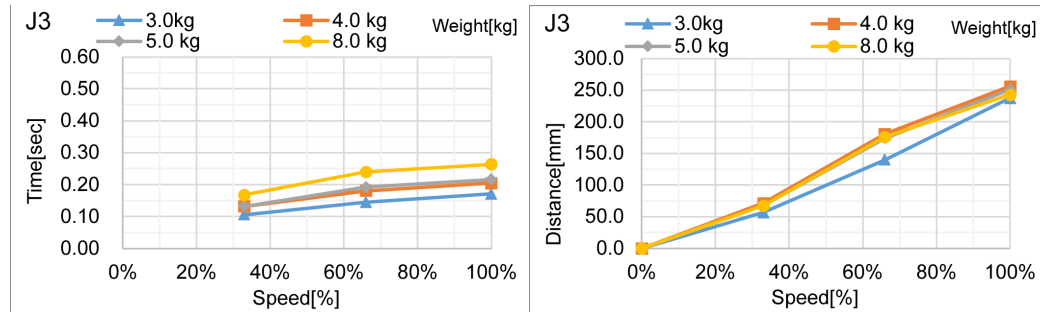

Boost mode

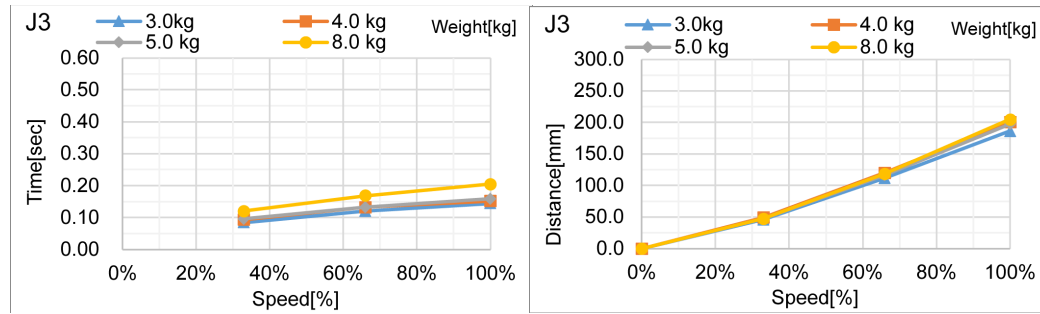

6.3.3 GX10 Stopping Time and Stopping Distance When Safeguard is Open

GX10-B/GX10-C65***: J1

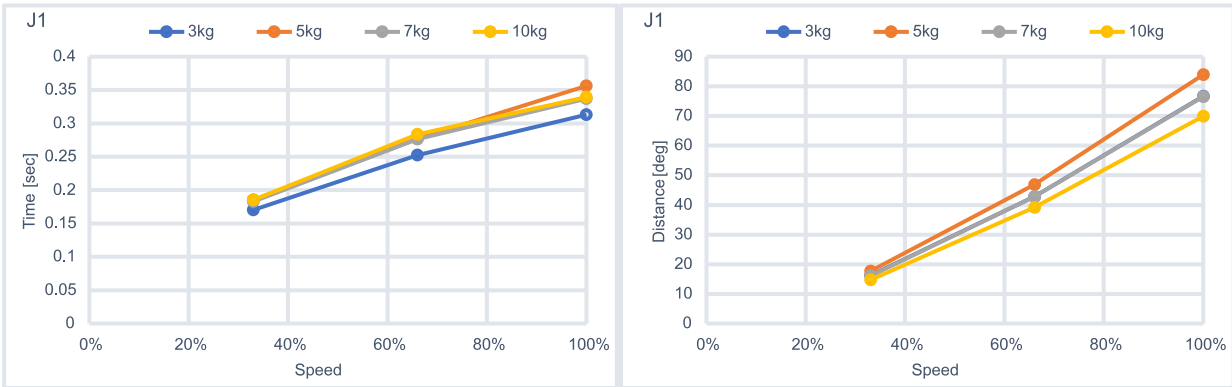

GX10-B/GX10-C65***: J2

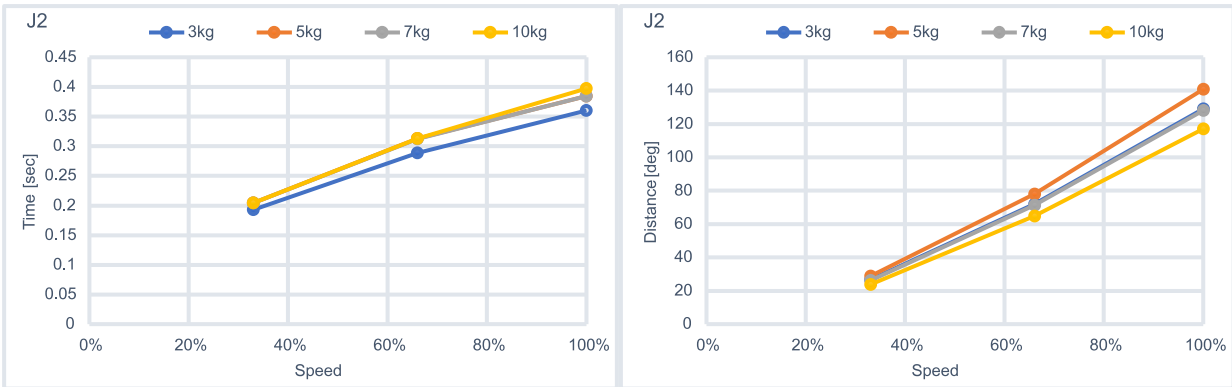

GX10-B/GX10-C65***: J3

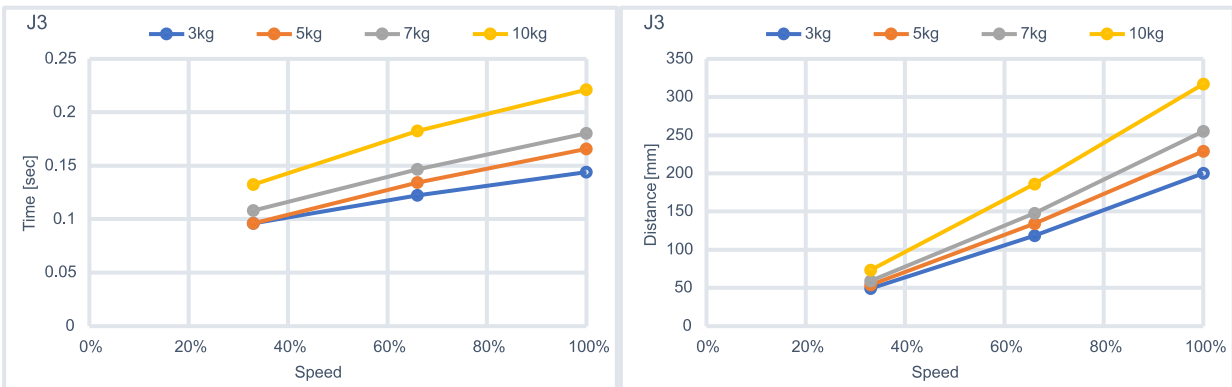

GX10-B/GX10-C85*: J1**

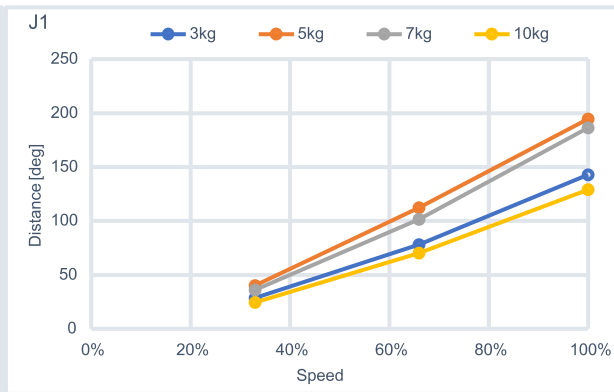
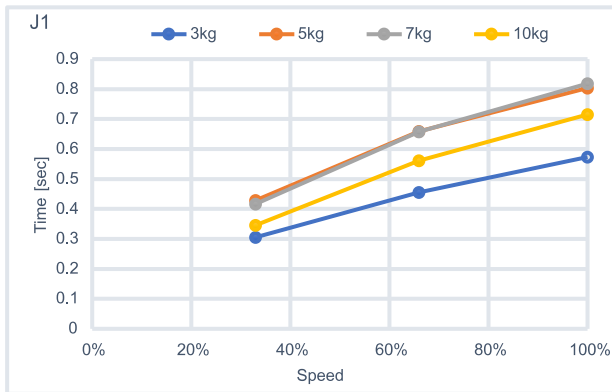

GX10-B/GX10-C85*: J2**

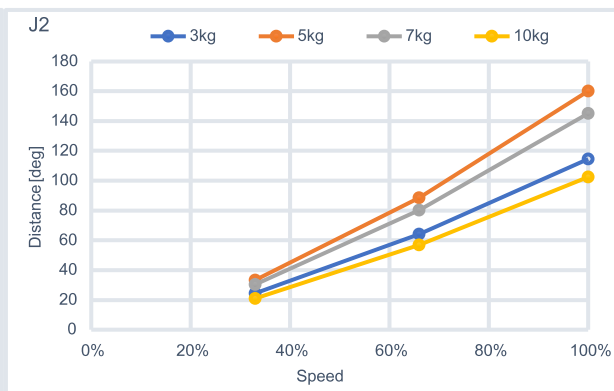
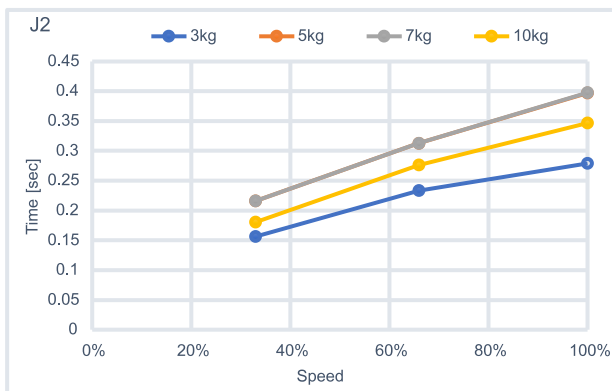

GX10-B/GX10-C85*: J3**

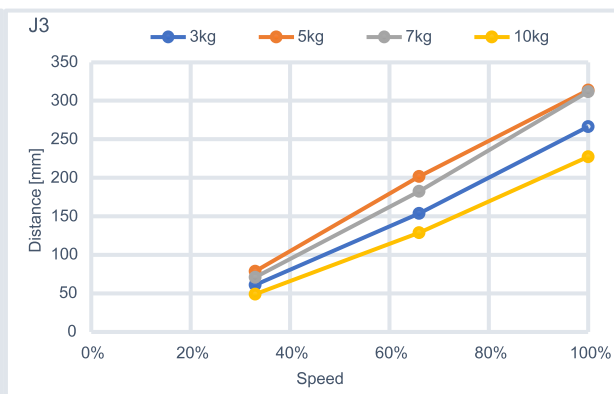
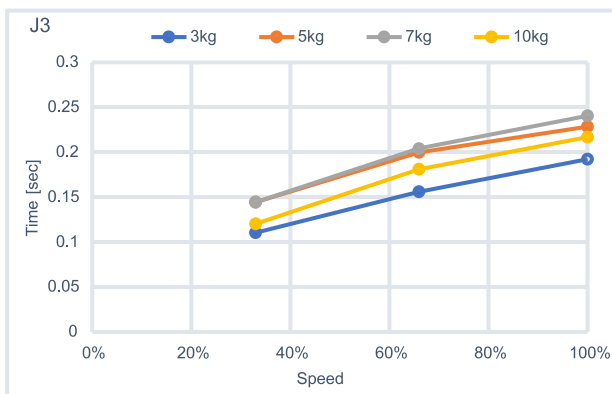

6.3.4 GX20 Stopping Time and Stopping Distance When Safeguard is Open

GX20-B/GX20-C85***: J1

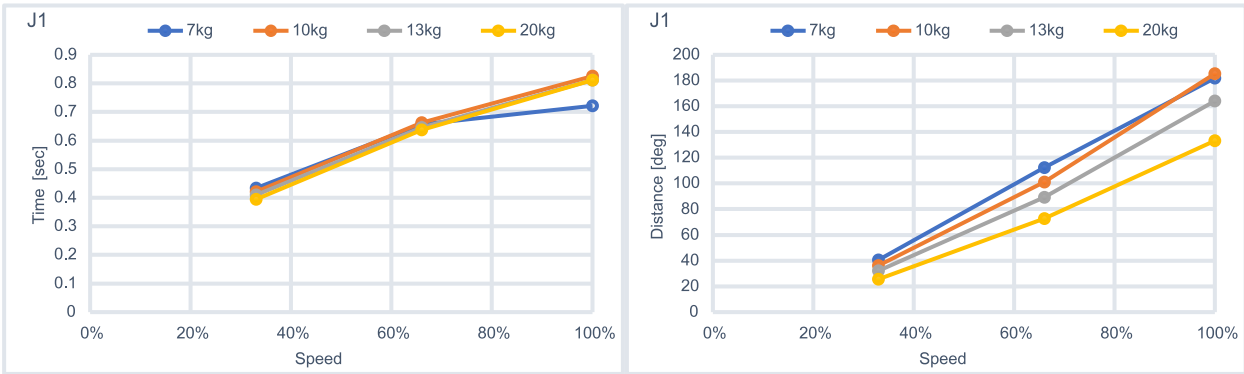

GX20-B/GX20-C85***: J2

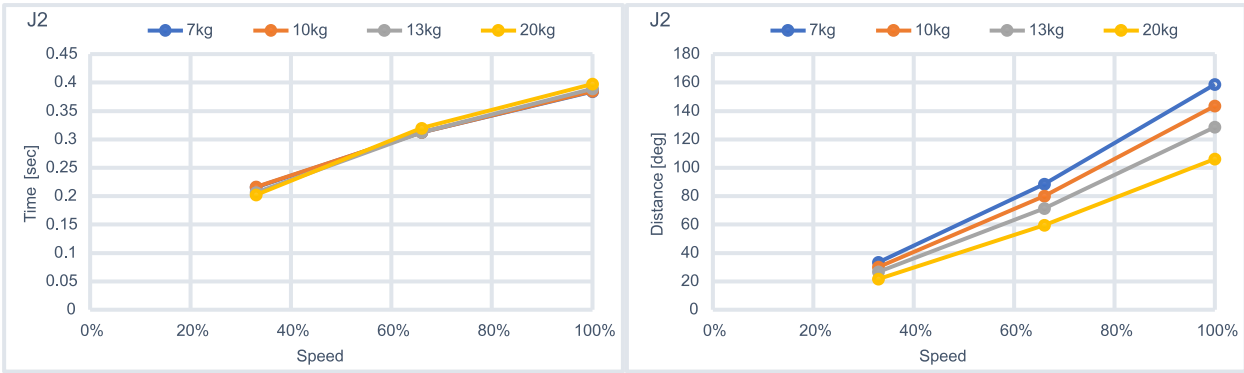

GX20-B/GX20-C85***: J3

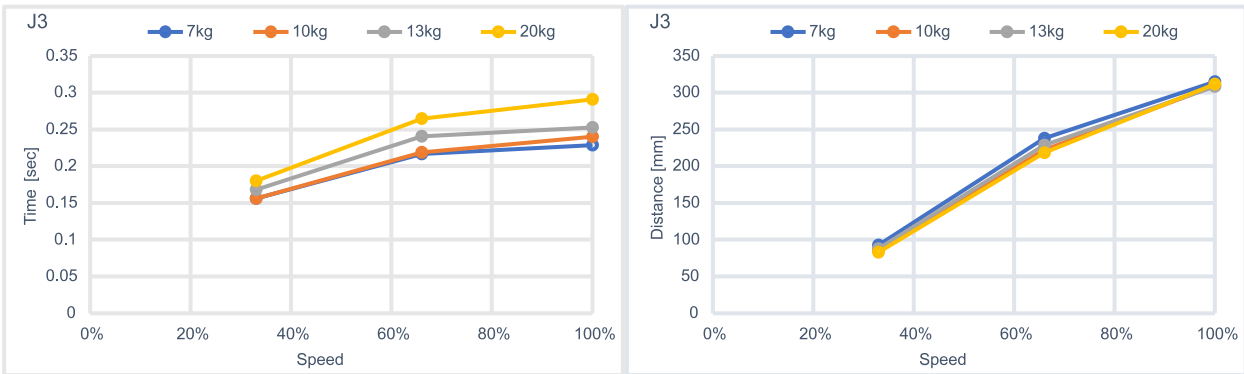

GX20-B/GX20-CA0*: J1**

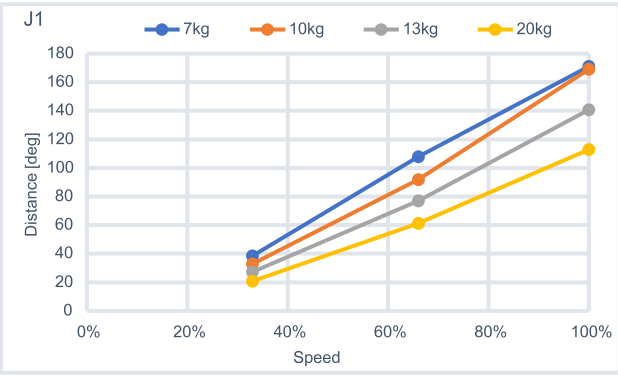
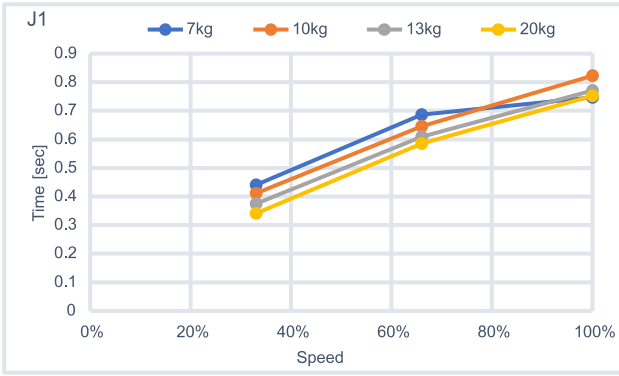

GX20-B/GX20-CA0*: J2**

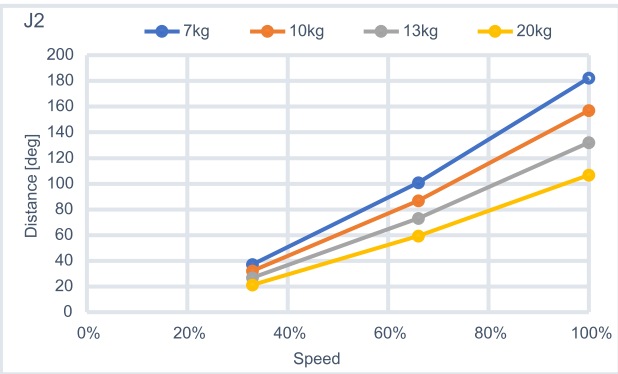
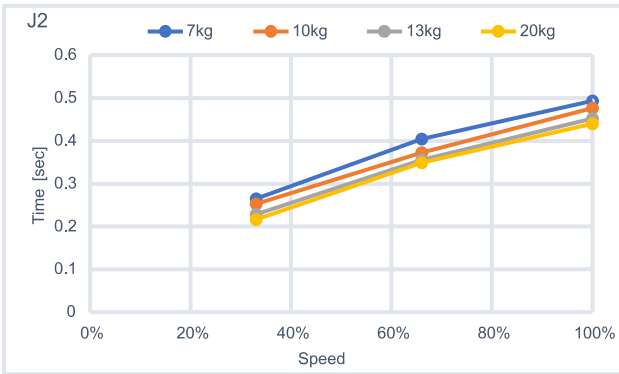

GX20-B/GX20-CA0*: J3**

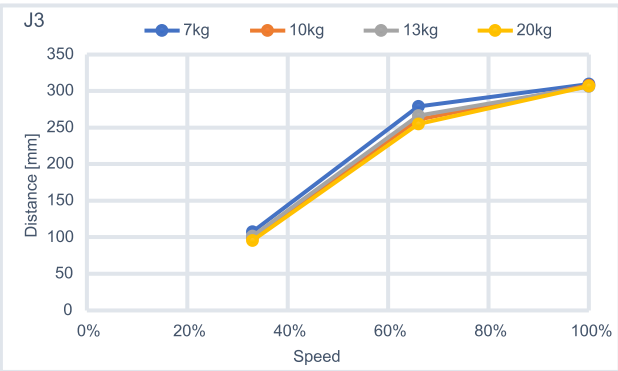
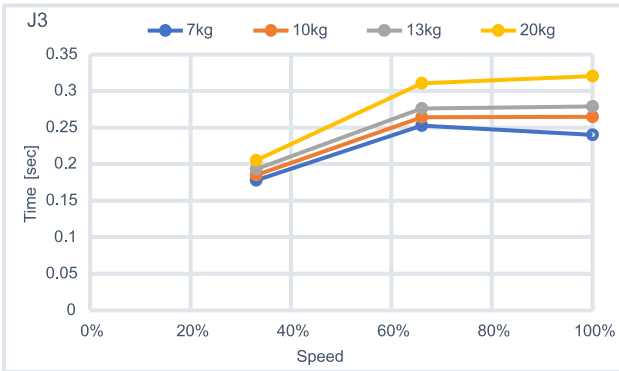

6.4 Appendix D: Correction Area for Arm Length Correction

This product is available with an option that enables correction of the arm length. (Model with table top mounting specifications only)

For details on available options, please contact the supplier.

For details on arm length calibration, refer to the following manual.

"Epson RC+ User's Guide - Arm Length Calibration"

This section shows the measured correction area as shipped. (Shaded area: Correction area, Units: mm)

The measured Z-axis position is shown below.

- GX4 series: Z = -130 mm
- GX8 series: Z = -180 mm

6.4.1 GX4 Series

GX4-A/GX4-B/
GX4-C251**

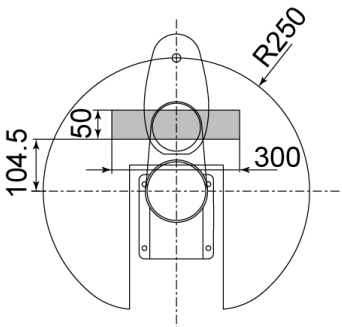

GX4-A/GX4-B/
GX4-C301**

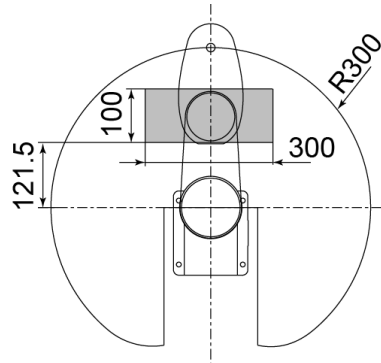

GX4-A/GX4-B/
GX4-C351**

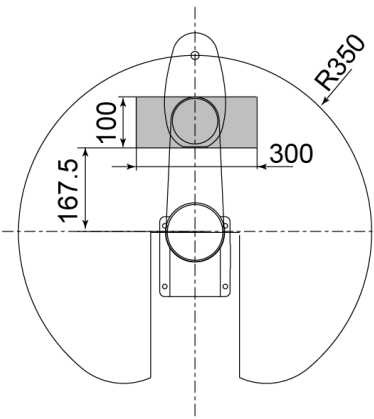

GX4-A/GX4-B/
GX4-C351**-L,R

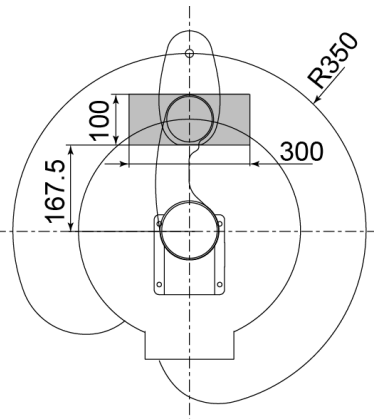

(The figure shows L.)

6.4.2 GX8 Series

GX8-A/GX8-B/
GX8-C45***

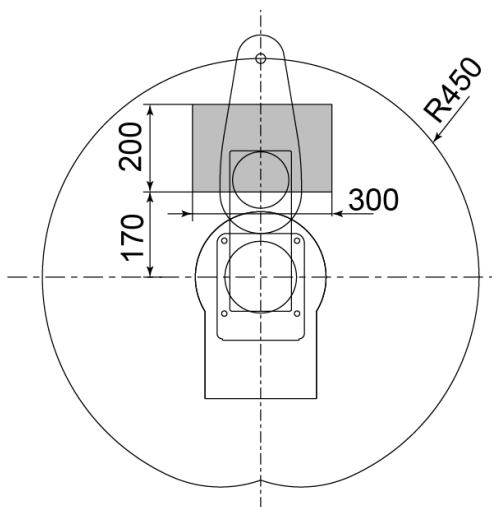

GX8-A/GX8-B/
GX8-C55***

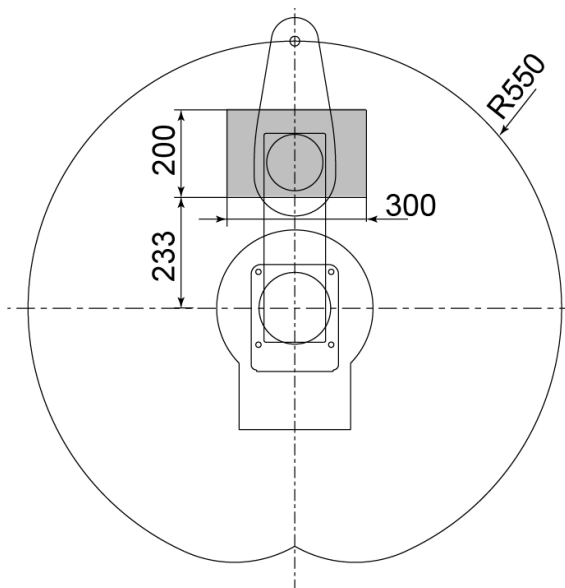

GX8-A/GX8-B/
GX8-C65***

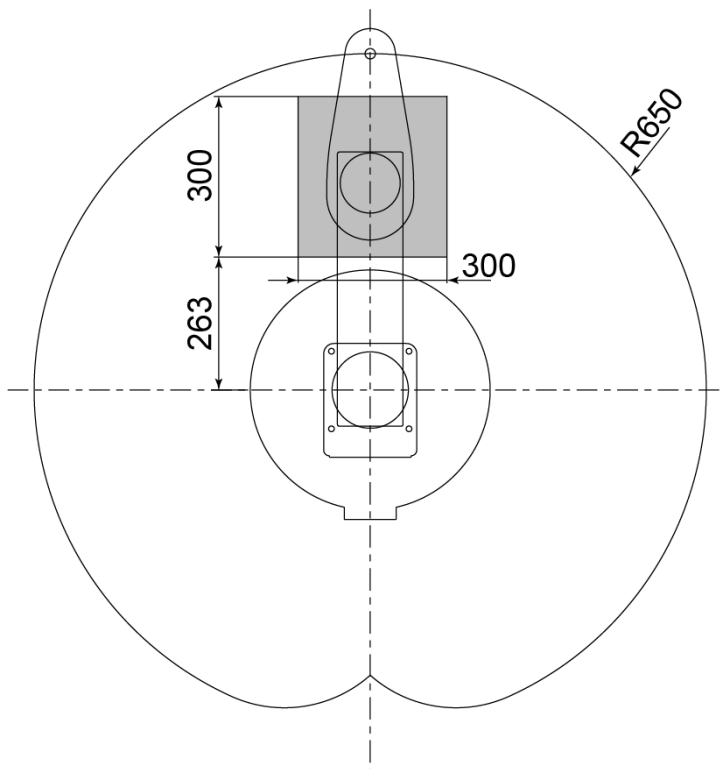

6.5 Appendix E: Included Items

The Manipulators are shipped with the following parts.

6.5.1 GX4 series

Name	Model number	Quantity
DSUB15_METALIZED_PLASTIC_HOOD	618 015 253 11	2
DSUB15_MALE_SOLDER_BUCKET	618 015 248 23	2
GREASE NIPPLE	A-M6F	1

6.5.2 GX8 series

For all the models except Protected-model

Name	Model number	Quantity
TENSIONER_A	-	1
TENSIONER_B	-	1
Hexagon head bolt	M4X25	1
Washer	M4	1
Hexagon socket head cap bolt (with washer)	M4X10	4
Hexagon head bolt	M6X20	2
DSUB9_METALIZED_PLASTIC_HOOD	618 009 253 11	2
DSUB15_METALIZED_PLASTIC_HOOD	618 015 253 11	2
DSUB9_MALE_SOLDER_BUCKET	618 009 248 23	2
DSUB15_MALE_SOLDER_BUCKET	618 015 248 23	2
EYE_BOLT	B-130-8	2
GREASE NIPPLE	A-M6F	1

Protected-model

Name	Model number	Quantity
TENSIONER_A	-	1
TENSIONER_B	-	1
Hexagon head bolt	M4X25	1
Washer	M4	1
Hexagon socket head cap bolt (with washer)	M4X10	4
Hexagon head bolt	M6X20	2
CONNECTOR/09 67 009 5615	09 67 009 5615	2
CONNECTOR ACCESSORY/09 67 009 0538	09 67 009 0538	2
CONNECTOR/09 67 015 5615	09 67 015 5615	2
CONNECTOR ACCESSORY/09 67 015 0538	09 67 015 0538	2
EYE_BOLT	B-130-8	2
GREASE NIPPLE	A-M6F	1

6.5.3 GX10/20 series**For Standard or Cleanroom specification / Table top mounting**

Name	Model number	Quantity
DSUB9_METALIZED_PLASTIC_HOOD	618 009 253 11	2
DSUB15_METALIZED_PLASTIC_HOOD	618 015 253 11	2
DSUB9_MALE_SOLDER_BUCKET	618 009 248 23	2
DSUB15_MALE_SOLDER_BUCKET	618 015 248 23	2
EYE_BOLT	B-130-8	2

For Protected-model / Table top mounting

Name	Model number	Quantity
CONNECTOR/09 67 009 5615	09 67 009 5615	2
CONNECTOR ACCESSORY/09 67 009 0538	09 67 009 0538	2
CONNECTOR/09 67 015 5615	09 67 015 5615	2
CONNECTOR ACCESSORY/09 67 015 0538	09 67 015 0538	2
EYE_BOLT	B-130-8	2

For Standard or Cleanroom specification / Ceiling mounting or Wall mounting

Name	Model number	Quantity
DSUB9_METALIZED_PLASTIC_HOOD	618 009 253 11	2
DSUB15_METALIZED_PLASTIC_HOOD	618 015 253 11	2
DSUB9_MALE_SOLDER_BUCKET	618 009 248 23	2
DSUB15_MALE_SOLDER_BUCKET	618 015 248 23	2
EYE_BOLT	TIB-10ML	2
Washer	M10	2

For Protected-model / Ceiling mounting or Wall mounting

Name	Model number	Quantity
CONNECTOR/09 67 009 5615	09 67 009 5615	2
CONNECTOR ACCESSORY/09 67 009 0538	09 67 009 0538	2
CONNECTOR/09 67 015 5615	09 67 015 5615	2
CONNECTOR ACCESSORY/09 67 015 0538	09 67 015 0538	2
EYE_BOLT	TIB-10ML	2
Washer	M10	2