

EPSON

Epson RC+ 8.0 Option

Part Feeding 8.0

Hopper (Gen.1)

Rev.2

ENM24ZS6913F

Original instructions

Epson RC+ 8.0 Option Part Feeding 8.0 Hopper (Gen.1) Rev.2

Epson RC+ 8.0 Option

Part Feeding 8.0 Hopper (Gen.1)

Rev.2

©Seiko Epson Corporation 2024

FOREWORD

Thank you for purchasing our robot system.

This manual contains the information necessary for the correct use of the Epson RC+ PartFeeding option.

Please carefully read this manual and other related manuals before installing the robot system.

Keep this manual handy for easy access at all times.

The robot system and its optional parts are shipped to our customers only after being subjected to the strictest quality controls, tests, and inspections to certify its compliance with our high performance standards. Please note that the basic performance of the product will not be exhibited if our robot system is used outside of the usage conditions and product specifications described in the manuals.

This manual describes possible dangers and consequences that we can foresee. Be sure to comply with safety precautions on this manual to use our robot system safely and correctly.

TRADEMARKS

Microsoft, Windows, Windows logo, Visual Basic, and Visual C++ are either registered trademarks or trademarks of Microsoft Corporation in the United States and/or other countries. Other brand and product names are trademarks or registered trademarks of the respective holders.

TRADEMARK NOTATION IN THIS MANUAL

Microsoft® Windows® 10 operating system

Microsoft® Windows® 11 operating system

Throughout this manual, Windows 10 and Windows 11 refer to above respective operating systems. In some cases, Windows refers generically to Windows 10 and Windows 11.

NOTICE

No part of this manual may be copied or reproduced without authorization.

The contents of this manual are subject to change without notice.

Please notify us if you should find any errors in this manual or if you have any comments regarding its contents.

MANUFACTURER

SEIKO EPSON CORPORATION

CONTACT INFORMATION

For detailed contact information, see "SUPPLIER" of the manual below.

"Safety Manual"

Hopper (Gen.1)

1. Safety Instructions	3
1.1 Safety Instructions for Hopper	3
1.2 Safety Instructions for Hopper Controller	7
1.2.1 Safety Notes	7
1.2.2 Safety Instructions for Starting	9
1.2.3 Safety Instructions of AC Power Cable	10
2. Specification	11
2.1 Specification of Hopper	11
2.2 Model Name	11
2L Hopper (series: IF-240)	11
3L Hopper (series: IF-240)	11
10L Hopper (series: IF-380)	11
15L Hopper (series: IF-530)	12
Option.....	12
2.3 Specification Table	13
2.4 Names of each Part and Outer Dimension, Mounting Dimension	13
2.4.1 Names of each Part.....	13
2.4.2 Outer Dimension, Mounting Dimension.....	14
2L Hopper (series: IF-240)	14
3L Hopper (series: IF-240)	14
10L Hopper (series: IF-380)	15
15L Hopper (series: IF-530)	16
Controller (common).....	17
3. Connecting Cable	18
4. Transport and Mounting	19
5. Maintenance	20
6. Troubleshooting	21





Hopper (Gen.1)

1. Safety Instructions

1.1 Safety Instructions for Hopper

The conception and production of our linear feeders has been carried out very carefully, in order to guarantee trouble-free and safe operation. You too can make an important contribution to job safety. Therefore, please read these short operating instructions completely before starting the machine. Always observe the safety instructions.

In this manual, the safety precautions that you must follow are classified as: “Warning”, “Caution” and “NOTE”; the following symbols are used:

 WARNING	This symbol indicates that a danger of possible serious injury or death exists if the associated instructions are not followed properly.
 WARNING	This symbol indicates that a danger of possible harm to people caused by electric shock exists if the associated instructions are not followed properly.
 CAUTION	This symbol indicates that a danger of possible harm to people or physical damage to equipment and facilities exists if the associated instructions are not followed properly.
NOTE 	The “NOTE” sections describe important information to be followed for operating the Robot system.

 WARNING	<ul style="list-style-type: none"> ■ The most dangerous parts of the machine are the electrical installations of the linear feeder. In case the linear feeder gets wet, there is the danger of an electric shock. ■ Make sure that the protection ground of the electric power supply is in perfect condition.
--	--

1. Safety Instructions

Intended use

The intended use of the linear feeder is the actuation of conveying tracks. These are used for linear transport and feeding of correctly positioned mass-produced parts, as well as for the proportioned feeding of bulk material. The intended use also includes the observance of the operating and servicing instructions.

Please take the technical data of your linear feeder from the table described in 2. *Technical data*. Make sure that the connected load of the linear feeder, control unit and power supply is compatible.

NOTE



- The linear feeder may only be operated in perfect condition.

The linear feeder may not be operated in the explosive or wet area.

The linear feeder may only be operated in the configuration drive unit, control unit and oscillating unit, as specified by the manufacturer.

No additional loads may act upon the linear feeder, apart from the material to be transported, for which the special type is designed.





CAUTION

- It is strictly prohibited to put any safety devices out of operation.

Demands on the user

- For all activities (operation, maintenance, repair, etc.) the details of the operating instructions must be observed.
- The operator must avoid any working method which would impair the safety of the linear feeder.
- The operator must take care that only authorized personnel work at the linear feeder.
- The user is obliged to inform the operator immediately about any changed conditions at the linear feeder that could endanger safety.

 WARNING	<ul style="list-style-type: none"> ■ Since the electromagnet-field may have an impact on persons with pacemakers it is recommended to keep a minimum distance of 25 cm.
 WARNING	<ul style="list-style-type: none"> ■ Unplug the main power plug when plugging / unplugging the cord. ■ Unplug the main power plug when performing adjustment and maintenance.
 CAUTION	<ul style="list-style-type: none"> ■ The linear feeder may only be installed, put into operation and serviced by expert personnel.

Noise emission

The noise level at the place of operation depends on the complete equipment and the material to be transported. The determination of the noise level according to the EC-Regulations “Machinery” can therefore only be carried out at the place of operation.

If the noise level at the place of operation exceeds the limit permitted, noise prediction hoods may be used, which we offer as accessory parts (see catalogue).

Standards and regulations

The device was built according to the following standards and regulations:

- Low voltage directive 2014/35/EU
- EMC directive 2014/30/EU

We assume that our product is to be integrated in a fixed machine. The provisions of the EMC directive 2014/30/EU must be considered by the user.

- Applied harmonized Standards
EN 60204-1

1. Safety Instructions

 <p>WARNING</p>	<ul style="list-style-type: none">■ When transporting and shipping, please take actions to prevent accidents for transporting and shipping.■ Build a safety system that shuts off the Hopper power when the machine or mechanical system protection enclosure is opened.■ Carry out inspections and maintenance considering safety.■ Be sure to comply with safety precautions of manual for the equipment used in the machine or machine system.■ Products with 50Hz specifications cannot be used by connecting to a 60Hz power supply.■ Products with 60Hz specifications cannot be used by connecting to a 50Hz power supply.
--	--

 <p>WARNING</p>	<ul style="list-style-type: none">■ Attach protective equipment* to the power supply line to the hopper controller. *: fuse, shutting down equipment for wires (MCCB), etc.■ When removing hopper from the machine or machine system, after unplugging the main power plug of the machine or machine system, and disconnect cable connection between hopper and hopper controller, remove the hopper.■ Before detaching protective equipment* of the machine or machine system, unplug the main power plug of the machine or machine system, and turn off the power. *: fuse, shutting down equipment for wires (MCCB), etc.■ When detached protective equipment* of the machine or machine system, before turning on the power, attach protective equipment again. *: fuse, shutting down equipment for wires (MCCB), etc.■ Before assembling the machine or machine system, adjusting, maintenance and repair, turn off the power by using proper power deactivation equipment, and it must be fixed so that it does not turn on again. If necessary, attach the sign* on the power deactivation equipment so that it can be recognized clearly. *: For example, "Do not turn the power on"
--	---

1.2 Safety Instructions for Hopper Controller

1.2.1 Safety Notes

The safety notes shall in any case be read and understood.



- There is a risk of electric shock.
- Before opening the device unplug the power plug.
- Unplug the main power plug when plugging / unplugging the cord. Unplug the main power plug when adjustment and maintenance.
- Attach protective equipment* to the power supply line to the hopper controller.
 - *: fuse, shutting down equipment for wires (MCCB), etc.
- When removing hopper from the machine or machine system, after unplugging the main power plug of the machine or machine system, and disconnect cable connection between hopper and hopper controller, remove the hopper.
- Before detaching protective equipment* of the machine or machine system, unplug the main power plug of the machine or machine system, and turn off the power.
 - *: fuse, shutting down equipment for wires (MCCB), etc.
- When detached protective equipment* of the machine or machine system, before turning on the power, attach protective equipment again.
 - *: fuse, shutting down equipment for wires (MCCB), etc.
- Before assembling the machine or machine system, adjusting, maintenance and repair, turn off the power by using proper power deactivation equipment, and it must be fixed so that it does not turn on again. If necessary, attach the sign* on the power deactivation equipment so that it can be recognized clearly.
 - *: For example, "Do not turn the power on".



WARNING

- Work at electrical equipment of the machine/equipment may only be carried out by a qualified electrician or by trained personnel under direction and supervision of a qualified electrician according to the electronic regulations.

All safety and danger notes at the machine / equipment must be observed.

The electrical equipment of a machine / equipment must be examined regularly. Faults, e.g., loose connections or damaged cables, must be eliminated immediately.

- When transporting and shipping, please take actions to prevent accidents for transporting and shipping.
- Build a safety system that shuts off the Hopper power when the machine or mechanical system protection enclosure is opened.
- Carry out inspections and maintenance considering safety.
- Be sure to comply with safety precautions of manual for the equipment used in the machine or machine system.
- Products with 50Hz specifications cannot be used by connecting to a 60Hz power supply.
- Products with 60Hz specifications cannot be used by connecting to a 50Hz power supply.

1.2.2 Safety Instructions for Starting

 <p>CAUTION</p>	<ul style="list-style-type: none">■ Before the mains connection is made and the control unit is switched on, the following points must in any case be checked:<ul style="list-style-type: none">- Is the control unit closed properly and with all screws?- Is the existing plug fixing devices locked into place/screwed down?- Are all cables and ducts undamaged?- Is the INTENDED USE guaranteed?- Does the mains voltage indication comply with the local power supply network?- Does the mains frequency indication at the oscillating drive comply with the local power supply network?- Is the correct operating mode set at the control unit? (on that read explanation operating mode)
--	--

Only if all above mentioned questions can be answered with yes, the control unit can be put into operation.

 <p>CAUTION</p>	<ul style="list-style-type: none">■ At initial starts or starts after repair work or exchange of control units/oscillating drives the minimum output should be set at the control unit before switching on the device. When bringing up the output it must be taken care for correct function.
---	--

1.2.3 Safety Instructions of AC Power Cable

 WARNING	<ul style="list-style-type: none"> ■ The work should be done by a person with that specialized knowledge and skills. ■ Make sure AC power ground cable (Green/yellow) connect to the earth terminal of power supply system. There is a risk of electric shock if this is not done properly. ■ Use disconnecting device for power connection cable and do not connect it directly to the factory power supply. ■ Select disconnecting device meets the safety standards of each country.
--	---

Item	50Hz Specification	60Hz Specification
AC power cable (2 wires)	L: Brown, N: Light blue	L: Black1, N: Black 2
Protection ground wire	Green/Yellow	Green/Yellow
Power cable width	1mm ²	AWG18
Cable length	1.5m	1.5m
Cable end	The terminal ferrule length 8mm	The terminal ferrule length 6 mm

2. Specification

2.1 Specification of Hopper

Option Hopper has following types.

For IF-240: 2L and 3L

For IF-380: 10L

For IF-530: 15L

Parts loading part is made in 1.4301 stainless. Each part can be loaded max. 15kg.

2.2 Model Name

2L Hopper (series: IF-240)

Product name	Specification *	Power consumption of linear feeder	Model number
2I HOPPER 230VAC 50Hz - 240	2L/230VAC/50Hz	120VA	R12NZ9017U
2I HOPPER 230VAC 60Hz - 240	2L/230VAC/60Hz	145VA	R12NZ9017V
2I HOPPER 115VAC 50Hz - 240	2L/115VAC/50Hz	110VA	R12NZ9017W
2I HOPPER 115VAC 60Hz - 240	2L/115VAC/60Hz	145VA	R12NZ9017X

3L Hopper (series: IF-240)

Product name	Specification *	Power consumption of linear feeder	Model number
3I HOPPER 230VAC 50Hz - 240	3L/230VAC/50Hz	120VA	R12NZ9017Y
3I HOPPER 230VAC 60Hz - 240	3L/230VAC/60Hz	145VA	R12NZ9017Z
3I HOPPER 115VAC 50Hz - 240	3L/115VAC/50Hz	110VA	R12NZ90181
3I HOPPER 115VAC 60Hz - 240	3L/115VAC/60Hz	145VA	R12NZ90182

10L Hopper (series: IF-380)

Product name	Specification *	Power consumption of linear feeder	Model number
10I HOPPER 230VAC 50Hz - 380	10L/230VAC/50Hz	120VA	R12NZ9018T
10I HOPPER 230VAC 60Hz - 380	10L/230VAC/60Hz	145VA	R12NZ9018U
10I HOPPER 115VAC 50Hz - 380	10L/115VAC/50Hz	110VA	R12NZ9018V
10I HOPPER 115VAC 60Hz - 380	10L/115VAC/60Hz	145VA	R12NZ9018W

2. Specification

15L Hopper (series: IF-530)

Product name	Specification *	Power consumption of linear feeder	Model number
15L HOPPER 230VAC 50Hz - 530	15L/230VAC/50Hz	120VA	R12NZ9019M
15L HOPPER 230VAC 60Hz - 530	15L/230VAC/60Hz	145VA	R12NZ9019N
15L HOPPER 115VAC 50Hz - 530	15L/115VAC/50Hz	110VA	R12NZ9019P
15L HOPPER 115VAC 60Hz - 530	15L/115VAC/60Hz	145VA	R12NZ9019Q

* NOTE: Model number will defer depending on the voltage and frequency used.

Also, you cannot change the voltage and frequency.

Hopper is composed of parts loading part, linear feeder, Controller, and cable set. (Hopper fixation kit is optional.)

Option

Series	Product name	Specification	Model number
IF-380	HOPPER FIXATION KIT - 380	Hopper fixation kit	R12NZ9018X
IF-530	HOPPER FIXATION KIT - 530	Hopper fixation kit	R12NZ901BX

* There is no hopper fixation kit for IF-240 series.

2.3 Specification Table

Main power source	Depends on the model number. Refer to specification in “2.2 Model Number”.	
Power consumption	Depends on the model number. Refer to specification in “2.2 Model Number”.	
Protection rating	IP54	
Length of connecting cable	Refer to “3. Connecting Cable”	
Vibration frequency Hz	100Hz when power frequency is 50Hz. 120Hz when power frequency is 60Hz.	
Fuse	6.3A	
Radio interference suppression	According to EMV -regulations	
Environment condition	No cleanroom model	
Safety Standard	50Hz	CE Marking EMC Directive, Machinery Directive, RoHS Directive
	60Hz	CE Marking EMC Directive, Machinery Directive, RoHS Directive UL standards UL1740, CAN/CSA-Z434

2.4 Names of each Part and Outer Dimension, Mounting Dimension

2.4.1 Names of each Part

Hopper consists of a “Loading parts” on which parts to be put into the feeder are placed and a “Linear feeder” that generates vibration.

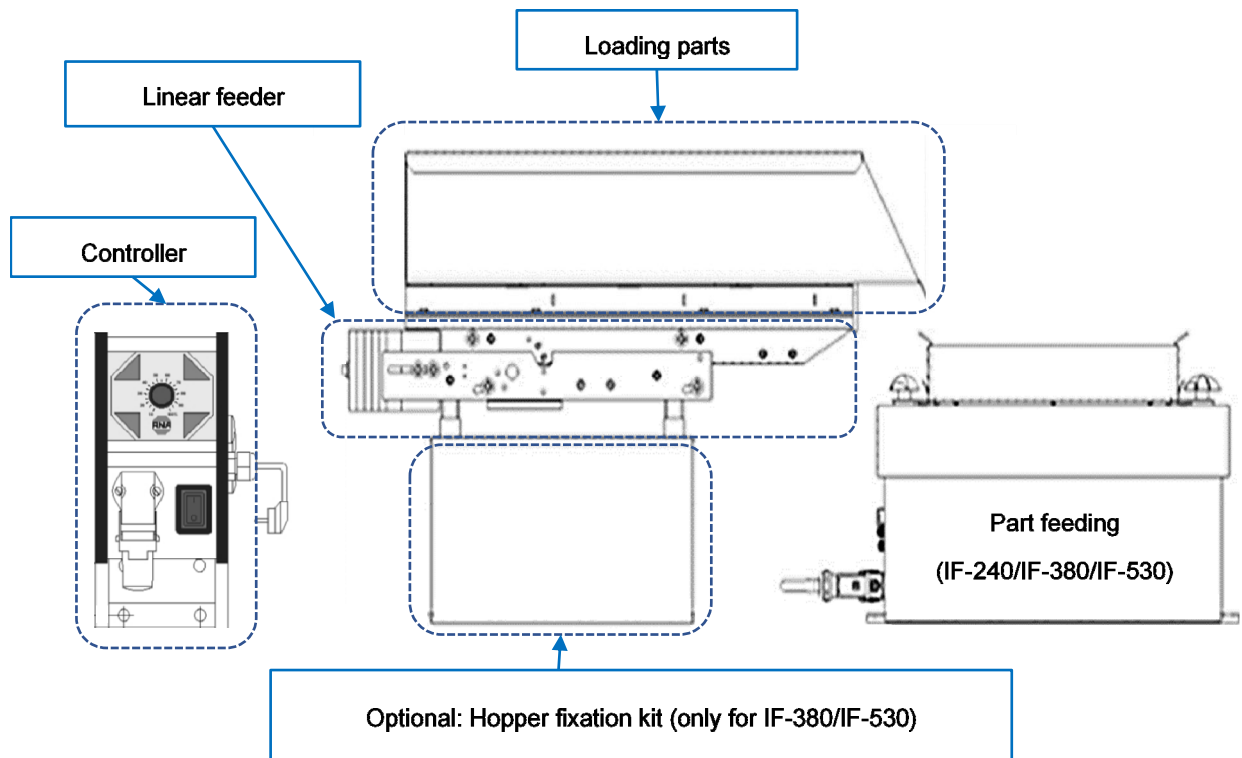

2.4.2 Outer Dimension, Mounting Dimension

2L Hopper (series: IF-240)

Hopper is mounted legs for fixation.

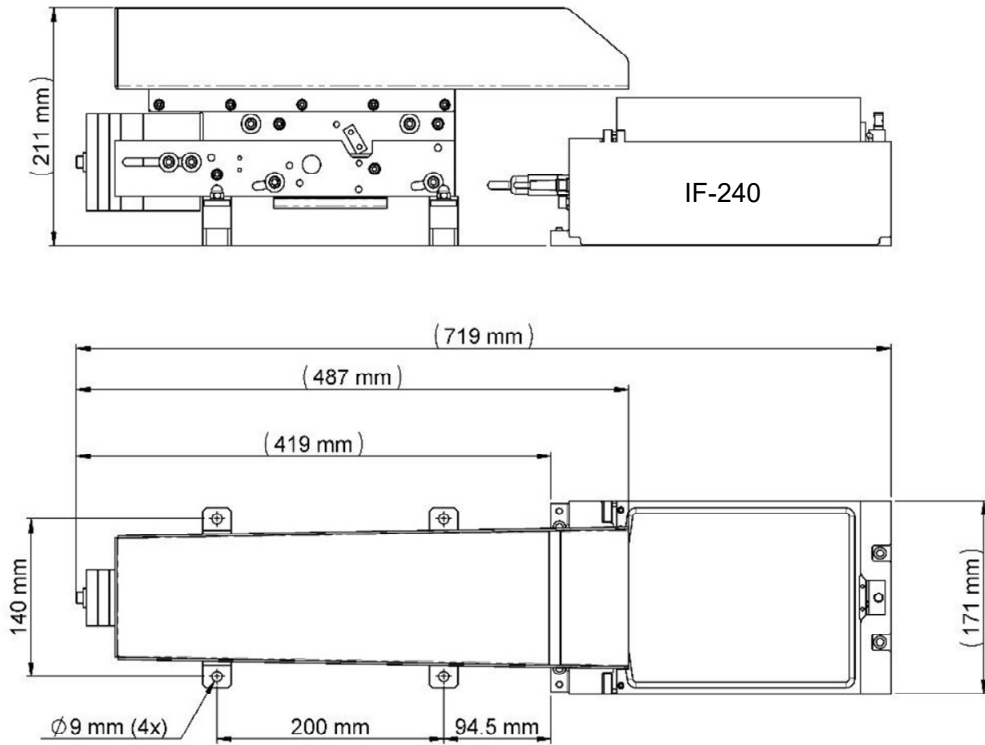

3L Hopper (series: IF-240)

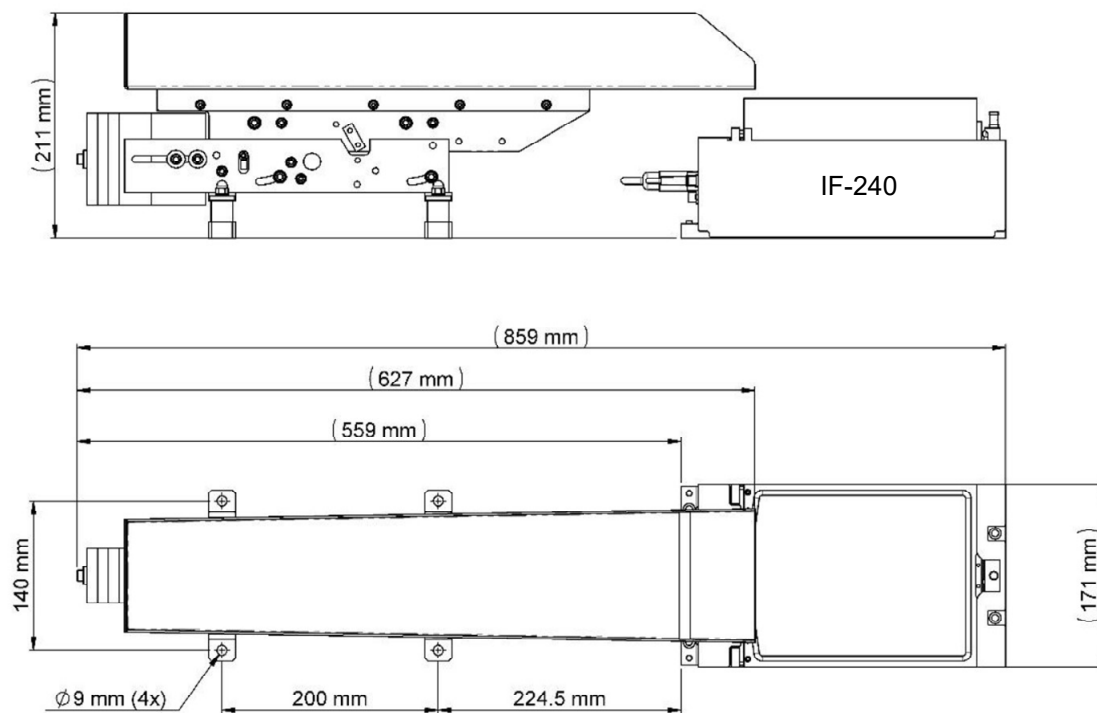

10L Hopper (series: IF-380)

With fixation kit:

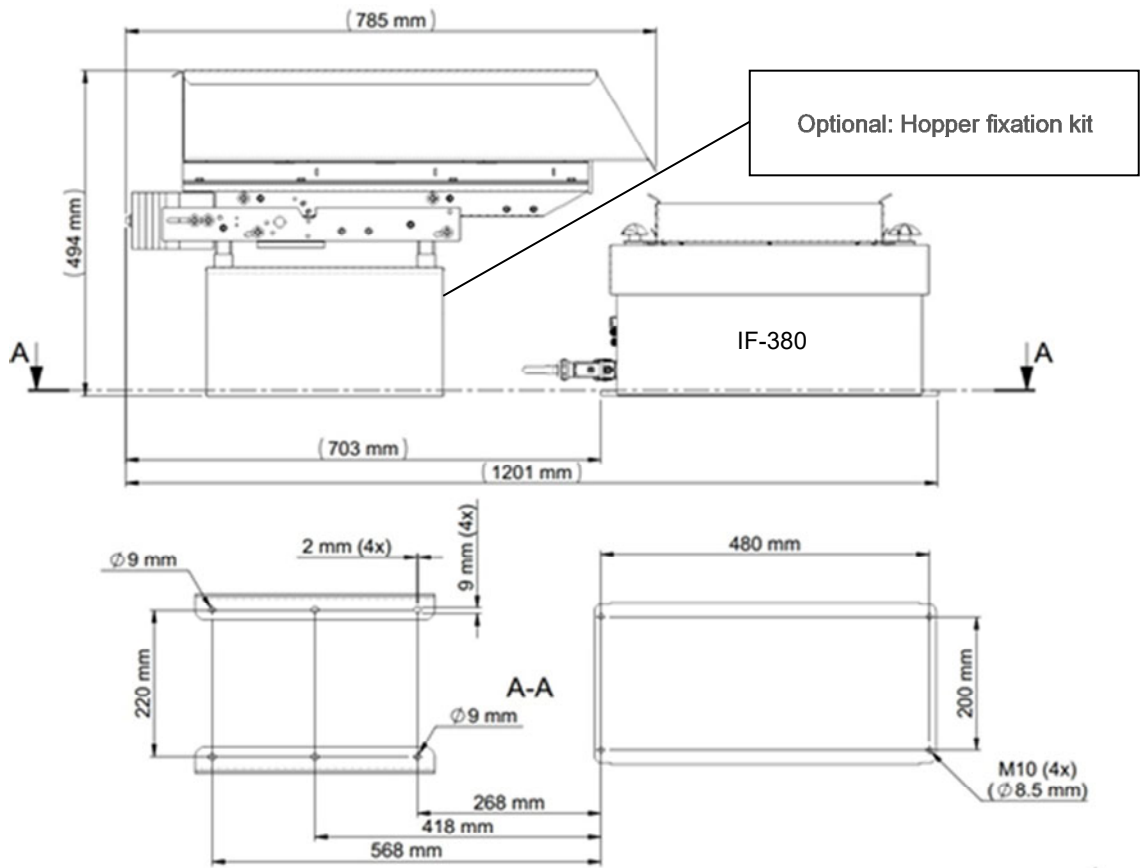

With no fixation kit:

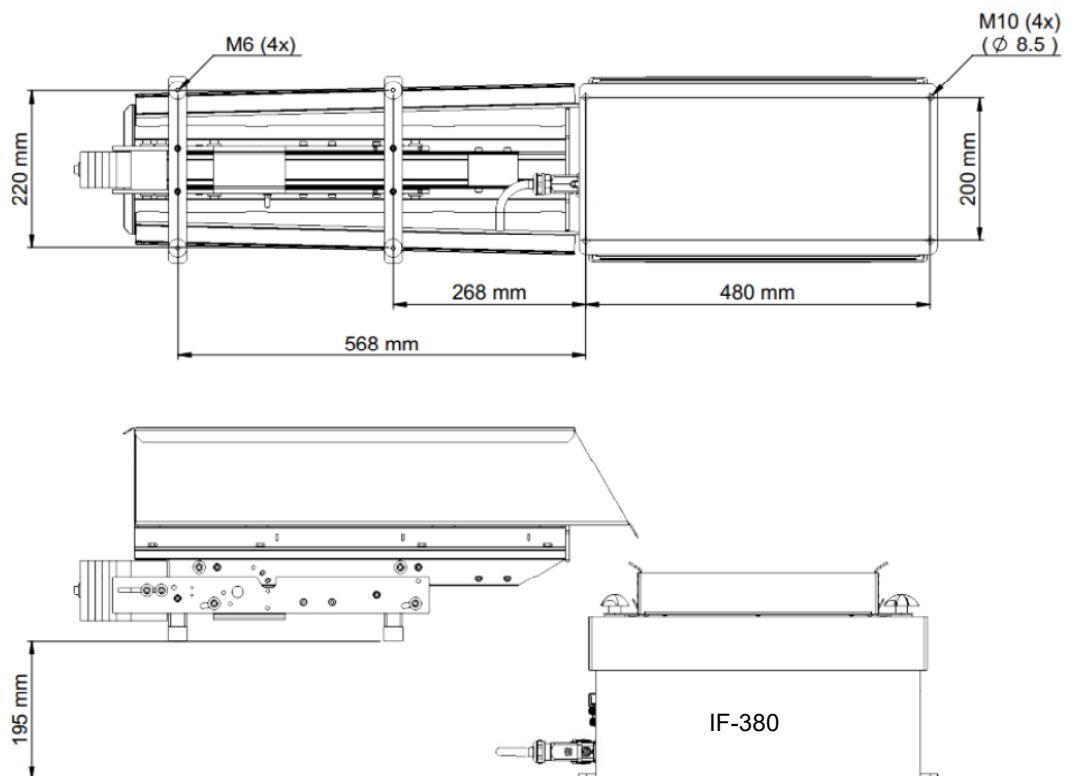

15L Hopper (series: IF-530)

With fixation kit:

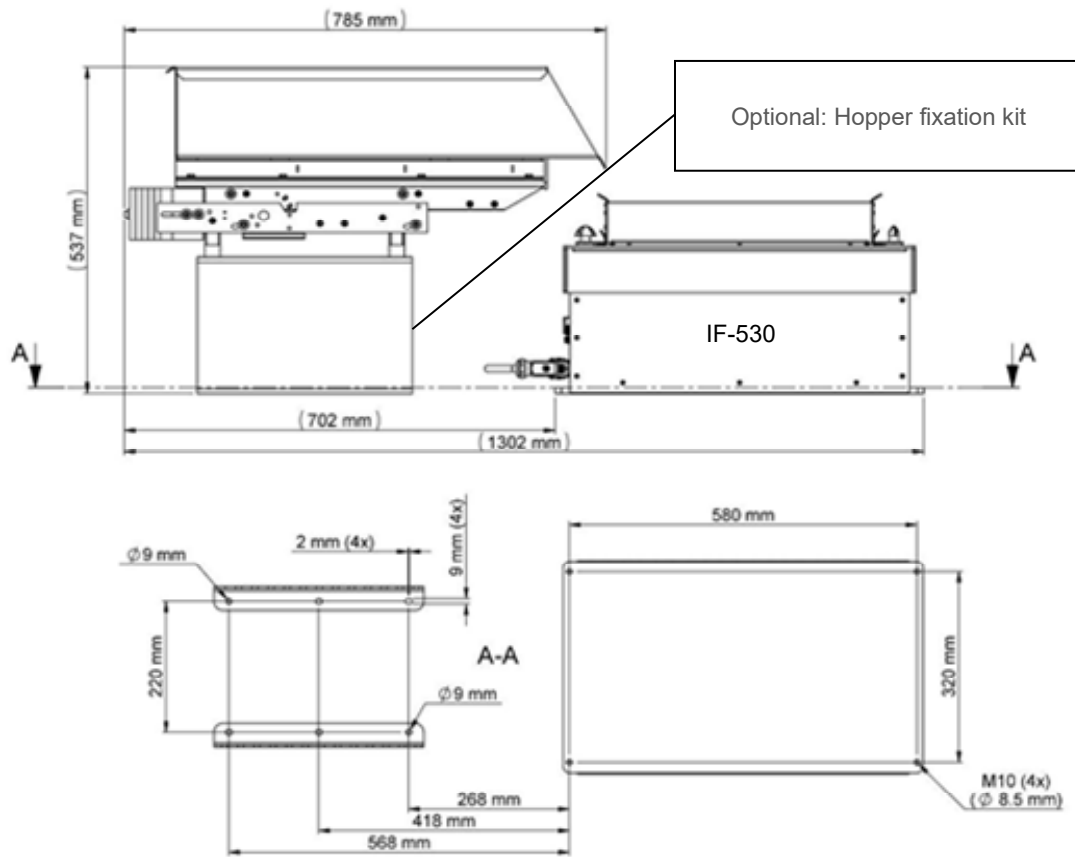

With no fixation kit:

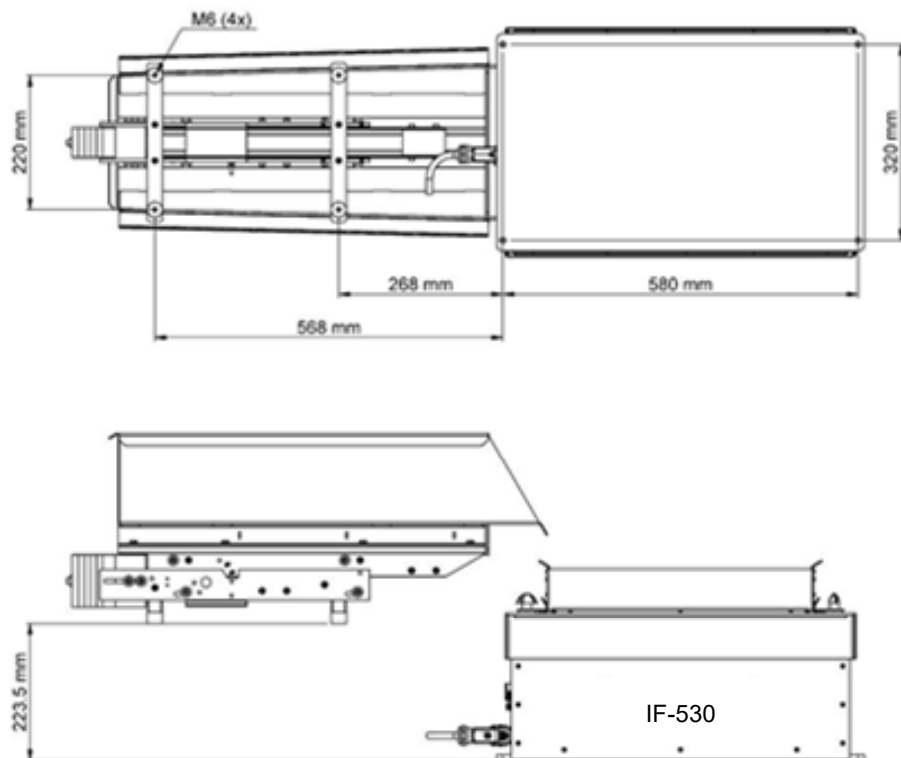

Controller (common)

The vibration intensity of the hopper can be adjusted with the potentiometer.

NOTE



- Place the Controller in a position that allows access to the potentiometer.

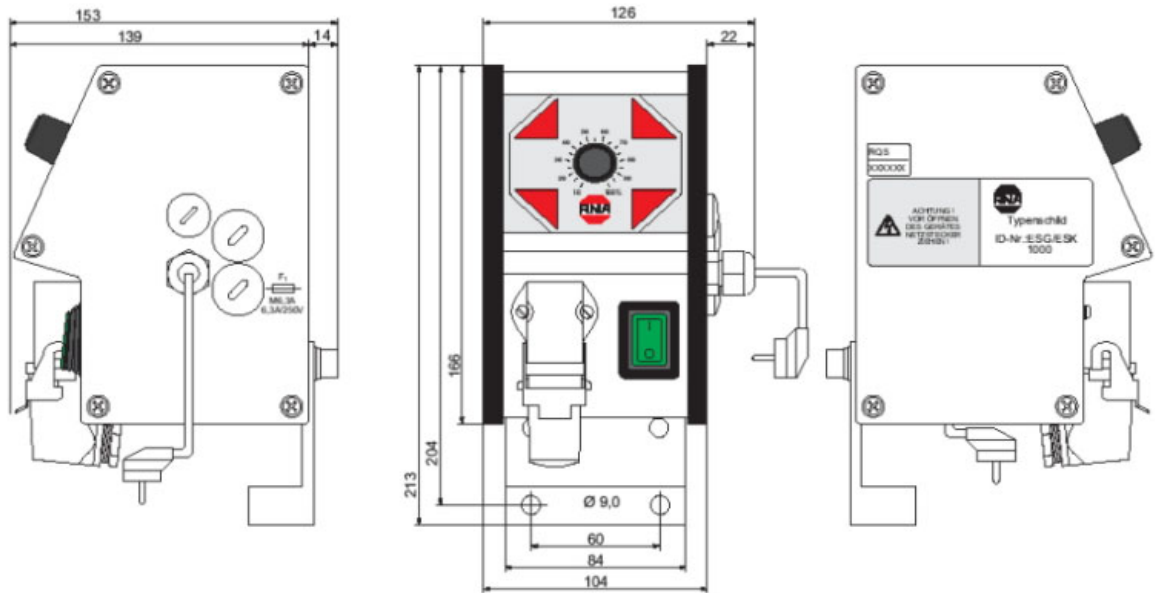

3. Connecting Cable

Connecting the cable that came with the linear feeder to the controller. Customers need to select power supply to connect to the Controller at the time of purchase.

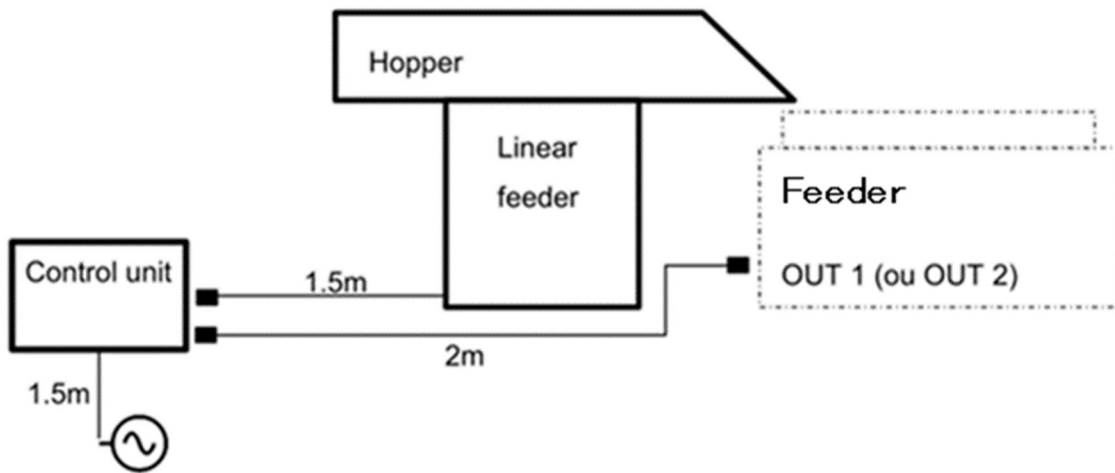

4. Transport and Mounting

Transport

NOTE



- Take care that the linear feeder cannot dash against other things during transport.

Mounting

The linear feeder should be mounted on a stable substructure at the place where it is used. The substructure must be dimensioned in a way that no vibrations of the linear feeder can be carried away.

For mounting dimensions, refer to “2.4.2 Outer Dimension, Mounting Dimension”.

Linear feeder has no cleanroom model.

During operation of linear feeder, do not let it touch to other equipment.



WARNING

- Be careful not to get hand, fingers, or feet caught and/or have equipment damaged by a fall of the Hopper. When working, please wear protective wear such as safety shoes.

5. Maintenance

The linear feeders are generally maintenance-free. They should, however, be thoroughly cleaned in case they are considerably dirty or after fluids have been spilled over them.

- For that first unplug the mains plug.
- Clean the inside of the linear feeder, especially the magnetic gap.

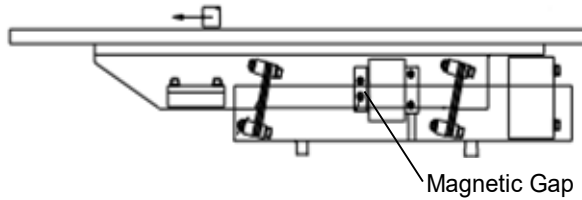

After the maintenance, plug the power supply, so that the linear feeder is ready for operation again.

6. Troubleshooting



- The Controller or the connecting terminal box may only be opened by an electrician. Before opening the a.m. devices, the mains plug must be unplugged.

Trouble/Check item	Possible cause	Remedy (Outline)
Linear feeder does not start when being switched on	<ul style="list-style-type: none"> - Mains switch is OFF. - Mains plug of the Controller is not plugged in. - Connecting cable between linear feeder and Controller is not plugged in. - Fuse in the Controller defective. 	<ul style="list-style-type: none"> - Switch ON the mains switch. - Plug in the mains plug. - Plug in the plug at the Controller. - Replace the fuse.
Linear feeder vibrates slightly	<ul style="list-style-type: none"> - Turning knob at the Controller is set to 0%. - Transport securing device has not been removed. - Wrong vibration frequency. 	<ul style="list-style-type: none"> - Set the Controller to 80%. - Remove the transport securing device. - Check, whether the power supply voltage , frequency and the voltage, frequency matches. (see 2.2 <i>Model Name</i>)
After a longer operating time the linear feeder does no longer come up to the conveying capacity required	<ul style="list-style-type: none"> - Mounting screws of the linear track have worked loose - Screws at one or two spring assemblies have worked loose 	<ul style="list-style-type: none"> - Tighten the mounting screws of the linear track. - Screw the spring of screw assembly.
Linear feeder produces loud noise	<ul style="list-style-type: none"> - Foreign bodies in the magnetic gap 	<ul style="list-style-type: none"> - Switch OFF the linear feeder and remove the foreign bodies.

