

# EPSON

EPSON RC+ 7.0 Option

*Part Feeding 7.0*

*IF-80*

Rev.6

ENM238S5884F

Original instructions

EPSON RC+ 7.0 Option Part Feeding 7.0 IF-80 Rev.6

EPSON RC+ 7.0 Option

**Part Feeding 7.0 IF-80**

Rev.6

©Seiko Epson Corporation 2020-2023

# FOREWORD

Thank you for purchasing our robot system.

This manual contains the information necessary for the correct use of the EPSON RC+ PartFeeding option.

Please carefully read this manual and other related manuals before installing the robot system.

Keep this manual handy for easy access at all times.

The robot system and its optional parts are shipped to our customers only after being subjected to the strictest quality controls, tests, and inspections to certify its compliance with our high performance standards. Please note that the basic performance of the product will not be exhibited if our robot system is used outside of the usage conditions and product specifications described in the manuals.

This manual describes possible dangers and consequences that we can foresee. Be sure to comply with safety precautions on this manual to use our robot system safely and correctly.

# TRADEMARKS

Microsoft, Windows, Windows logo, Visual Basic, and Visual C++ are either registered trademarks or trademarks of Microsoft Corporation in the United States and/or other countries. Other brand and product names are trademarks or registered trademarks of the respective holders.

# TRADEMARK NOTATION IN THIS MANUAL

Microsoft® Windows® 8 operating system

Microsoft® Windows® 10 operating system

Microsoft® Windows® 11 operating system

Throughout this manual, Windows 8, Windows 10 and Windows 11 refer to above respective operating systems. In some cases, Windows refers generically to Windows 8, Windows 10 and Windows 11.

# NOTICE

No part of this manual may be copied or reproduced without authorization.

The contents of this manual are subject to change without notice.

Please notify us if you should find any errors in this manual or if you have any comments regarding its contents.

# MANUFACTURER

**SEIKO EPSON CORPORATION**

# CONTACT INFORMATION

Contact information is described in “SUPPLIERS” in the first pages of the following manual:

*Robot System Safety Manual Read this manual first*

## Hardware (IF-80)

<b>1. Safety</b>	<b>3</b>
1.1 Overview .....	3
1.2 Safety Precautions .....	4
1.2.1 General Safety Precaution .....	4
1.2.2 Danger .....	5
<b>2. Specifications</b>	<b>7</b>
2.1 Characteristics of IF-80 .....	7
2.2 Model .....	7
2.3 Part Names and Overall Dimensions .....	8
2.3.1 Part Names .....	8
2.3.2 Overall Dimensions .....	9
2.3.3 Visual Signals .....	10
2.3.4 Maximum Permissible External Force on the Platform .....	11
2.3.5 Permissible Platform Weight .....	11
2.3.6 Permissible Hopper Weight .....	11
2.3.7 Maximum Plate Displacement .....	12
2.3.8 Plate Z Repeatability .....	12
2.4 Specification Table .....	13
2.4.1 Specification of IF-80 .....	13
2.4.2 Picking Surface .....	14
<b>3. Environment and Installation</b>	<b>15</b>
3.1 Environment .....	15
3.1.1 Installation Environment .....	15
3.1.2 Storage Environment .....	15
3.2 Base Table .....	16
3.3 Installing IF-80 .....	16
3.4 Unpacking and Transportation .....	17
3.4.1 Unpacking .....	17
3.4.2 Packaging of the Product, Transportation and Handling .....	18
3.5 Installation .....	19
3.5.1 Symbols and Acronyms in this Manual .....	19
3.5.2 Installing Part Feeding .....	21
3.5.3 Vibration Decoupling .....	22
3.5.4 Minimal Distance Between Part Feeding .....	25
3.5.5 Technical Data Tables .....	26
3.6 Connecting Cable .....	29
3.6.1 Overview .....	29
3.6.2 Power Connection .....	30
3.6.3 Communication .....	32

<b>4 Option</b>	<b>33</b>
4.1 Platform.....	33
4.1.1 Platform Type.....	33
4.1.2 Standard Platforms Usage.....	35
4.1.3 Plate Fixation Kit.....	36
4.1.4 Dimension of Platform.....	38
4.1.5 Platform with Purge.....	38
4.2 Hopper .....	39
4.3 Backlight .....	40
4.3.1 Color Options .....	40
4.3.2 Selecting a Backlight Color.....	40
4.3.3 IR Backlight.....	41
4.3.4 Backlight Overheat Prevention .....	42
4.4 Cables.....	43
<b>5. Maintenance and Component Replacement</b>	<b>44</b>
5.1 Safety Precautions.....	44
5.1.1 General Safety Precautions.....	44
5.1.2 Specific Warnings .....	44
5.2 Maintenance .....	45
5.2.1 Periodic Maintenance Schedule .....	45
5.2.2 Removing the Platform Module .....	46
5.2.3 Control and Cleaning of the Platform .....	47
5.3 Component Replacement.....	48
5.3.1 Exchange of the Backlight.....	49
5.3.2 Resetting IP Address .....	50
<b>6. Option Part List</b>	<b>52</b>
6.1 Feeder (series: IF-80).....	52
6.2 Plate (series: IF-80) .....	52
6.2.1 Plate (Anti-static).....	52
6.2.2 Plate (FDA) .....	53
6.2.3 Plate for Purging Option (Anti-static).....	53
6.2.4 Plate for Purging Option (FDA).....	54
6.3 Hopper (series: IF-80).....	54
6.4 Others, Accessories (series: IF-80).....	54
6.5 Backlight (series: IF-80).....	55
6.6 License (series: common).....	55
<b>7. Troubleshooting</b>	<b>56</b>

# Hardware (IF-80)









# 1. Safety

## 1.1 Overview

Before operating your product, please read this manual in order to ensure correct use of the product. Nevertheless, if you meet difficulties during operation or maintenance, please, feel free to contact the supplier of your region.

In this manual, the safety precautions that you must follow are classified as: “Warning”, “Caution” and “NOTE”; the following symbols are used:

 WARNING	This symbol indicates that a danger of possible serious injury or death exists if the associated instructions are not followed properly.
 WARNING	This symbol indicates that a danger of possible harm to people caused by electric shock exists if the associated instructions are not followed properly.
 CAUTION	This symbol indicates that a danger of possible harm to people or physical damage to equipment and facilities exists if the associated instructions are not followed properly.

NOTE 	The “NOTE” sections describe important information to be followed for operating the Robot system.
---	---



REFER TO ...

For more information on a specific subject, the reader should read another manual, or refer to other paragraph.

 CAUTION	<ul style="list-style-type: none"> <li>■ Epson shall not be liable whatsoever for any loss or damage arising from a failure to observe the items specified in Safety precautions. The customer is responsible for providing the necessary instructions to the persons concerned.</li> </ul>
--	---

NOTE 	<ul style="list-style-type: none"> <li>■ All dimensions in this manual are expressed in millimeters.</li> </ul>
---	---

## 1.2 Safety Precautions

### 1.2.1 General Safety Precaution

#### 1.2.1.1 Transport

 <p>CAUTION</p>	<ul style="list-style-type: none"><li>■ Be aware of the weight and take care when transporting the system. For more information, please refer to 3. <i>Environment and Installation</i>.</li></ul>
--	--

#### 1.2.1.2 General

 <p>WARNING</p>	<ul style="list-style-type: none"><li>■ Be sure that all power sources and other cables to the unit are disconnected before working on the product.</li><li>■ Only qualified personnel (trained by Epson and with professional experience) are authorized to work on this device.</li><li>■ Do not plug or unplug cables of the system unless it is switched off.</li><li>■ Never modify the product. Unauthorized modification may cause the product to malfunction, resulting in injury, electric shock, fire, etc.</li><li>■ Turn off the power to the product in the event of power failure. Failure to do so may cause the product to suddenly start moving when the power is restored.</li><li>■ Do not use the product in a place where it may come in contact with water or oil droplets.</li></ul>
--	---

 <p>WARNING</p>	<ul style="list-style-type: none"><li>■ Do not access the housing of the system controls. Serious injury or death could result from electric shock. Only authorized personnel from Epson are allowed to access this part of the system for maintenance or for repair.</li></ul>
--	---

 <p>CAUTION</p>	<ul style="list-style-type: none"><li>■ Build a safety system that shuts off the IF series power (S-Power) when the machine or mechanical system protection enclosure is opened.</li></ul>
--	--

1.2.1.3 Disposal

When the product becomes no longer usable or necessary, dispose of it properly as industrial waste.

 CAUTION	<ul style="list-style-type: none"> <li>Observe the valid legal regulations for appropriate disposal protecting environment.</li> </ul>
--	--



1.2.2 Danger



1.2.2.1 Safety equipment for operators

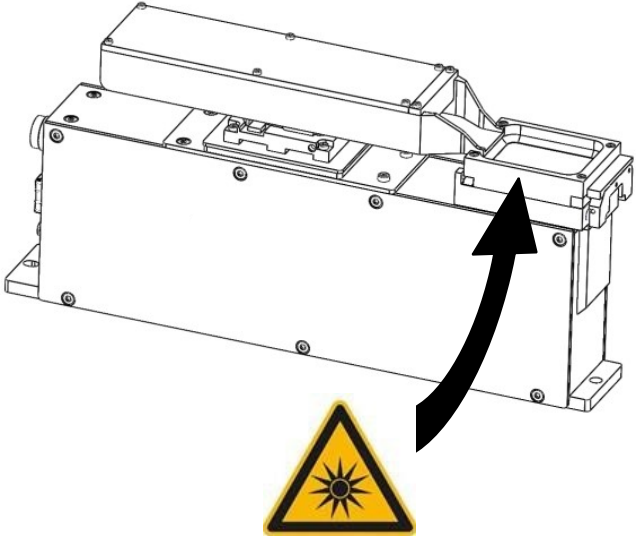

For safety reasons operators must wear protective eyewear when using the backlight.

NOTE 	<ul style="list-style-type: none"> <li>It is the customer's responsibility to install warning signs informing that anyone working around the part feeder must wear safety equipment.</li> </ul>
---	---

1.2.2.2 Specific danger

 WARNING  	<ul style="list-style-type: none"> <li><b>Backlight</b></li> </ul> <p>The part feeder has an integrated Backlight that uses LEDs (Light Emitting Diodes). These LEDs emit visible or non-visible radiation depending on the color of the Backlight. LEDs illumination can create discomfort, cornea, retinal and lens damage.</p> <p>Never look directly into the light source without any personal protection (e.g. protective eyewear). Customers are encouraged to document their unique application and instruct employees on procedures to limit exposure to LED radiation. This Backlight is not constructed to be used permanently. Please switch off the illumination after image acquisition. (Autoswitch OFF after a 30 second timeout).</p> <div style="text-align: center;">  </div> <p style="text-align: center;">Figure 1-1: Specific warnings</p>
---	---

 <p>WARNING</p> 	<ul style="list-style-type: none"> <li>■ The LEDs used are risk group 2 according to the norm EN 62471. It is the responsibility of customers to document their own application and instruct employees on procedures to limit exposure to LED radiation. The following prevention agent can be suggested:             <ul style="list-style-type: none"> <li>A Interpose, insofar as the job allows, a high pass filter at x nm depending on the color (see 2.6.5 <i>Backlight</i>) under a fixed or adjustable connection between the source and the employee.</li> <li>B When the implementation of the foregoing is not possible, provide workers with goggles or face shield suitable for blocking radiation beyond 700nm.</li> <li>C Prohibit or limit as possible direct access to the source. (exposure in the axis of radiation)</li> <li>D Establish a security perimeter to prevent operators from approaching the source at distances beyond the nominal ocular hazard recommended by the manufacturer.</li> <li>E In all cases, ensure that the means used properly mitigate exposure variables (characteristics of screens or goggles to choose based on wavelength which operators are exposed).</li> </ul> </li> </ul>
--	---

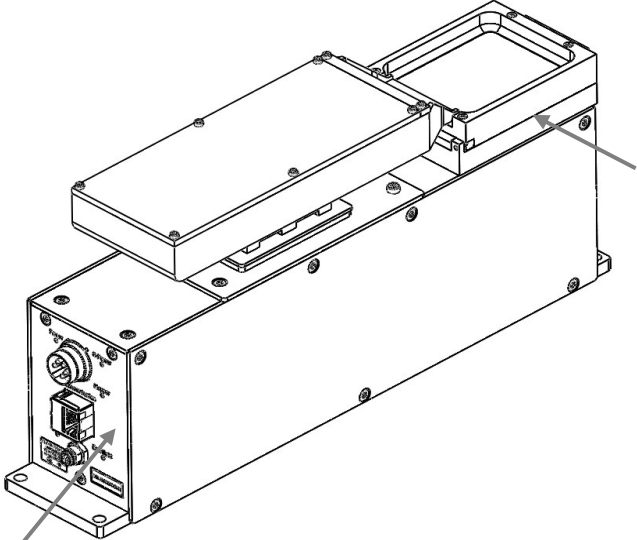
 <p>CAUTION</p> 	<ul style="list-style-type: none"> <li>■ Temperature</li> </ul> <p>The active elements in the IF-80 make the surfaces shown in the Figure 1-2 heats up to 40°C in normal use. This temperature can nevertheless increase to 55°C in extreme use.</p> <p>It is the responsibility of customers to document their own application and instruct employees on procedures to avoid contact with these surfaces.</p> <div style="text-align: center; margin-top: 20px;">  </div> <p style="text-align: center;">Figure 1-2: Specific warnings</p>
--	---

## 2. Specifications

### 2.1 Characteristics of IF-80

The IF-80 sets new standards in miniature part feeding. Its 3D vibratory platform allows fast and flexible presentation of small parts (3 mm ~ 8 mm) to a robot equipped with a vision system.

### 2.2 Model

Model numbers of IF-80

Product name	Specification	Model number
IF80 no Light	IF80 (No backlight)	R12NZ9015B
IF80 RED	IF80+backlight: Red	R12NZ9015C
IF80 WHITE	IF80+backlight: White	R12NZ9015D
IF80 GREEN	IF80+backlight: Green	R12NZ9015E
IF80 BLUE	IF80+backlight: Blue	R12NZ9015F
IF80 INFRARED	IF80+backlight: Infrared light	R12NZ9015G

## 2.3 Part Names and Overall Dimensions

### 2.3.1 Part Names

Names of each part:

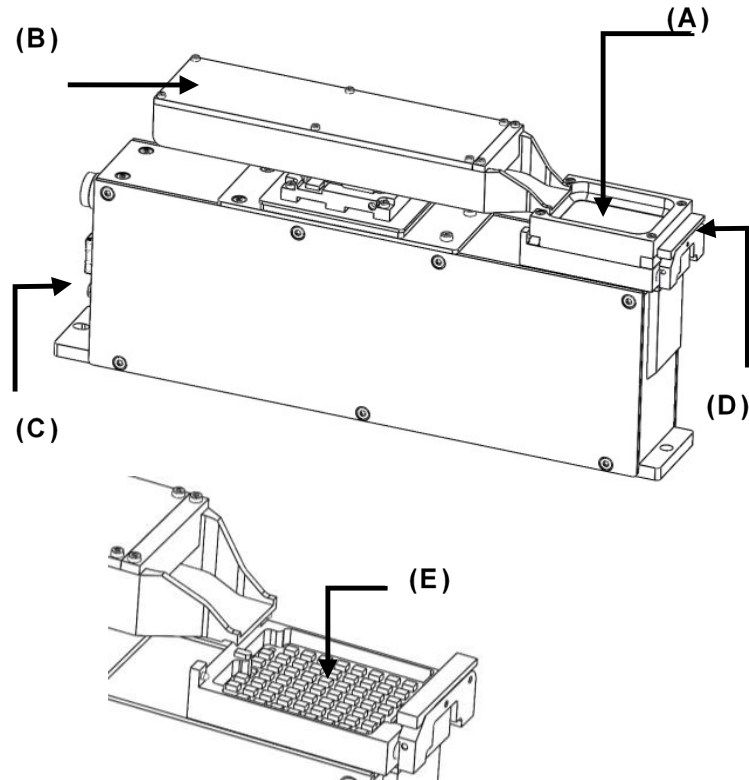

Figure 2-1: IF-80 overview

- (A) 3D vibrating platform
- (B) A removable hopper where the components are stored.
- (C) Electrical interfaces (communication, power supply, I/Os...)
- (D) An integrated mechanism allowing to remove the platform easily without additional tooling
- (E) An integrated backlight (optional) that allows an easy recognition of the parts from a camera placed above



(C) For details, refer to 3.6 *Conneting Cable*



(D) For more information on how to remove or change the platform, refer to 5.2.2 *Removing the platform module*



(E) For more information on the backlight color and the procedure to exchange the backlight, refer to 5.3.1 *Exchange of the backlight*

## 2.3.2 Overall Dimensions

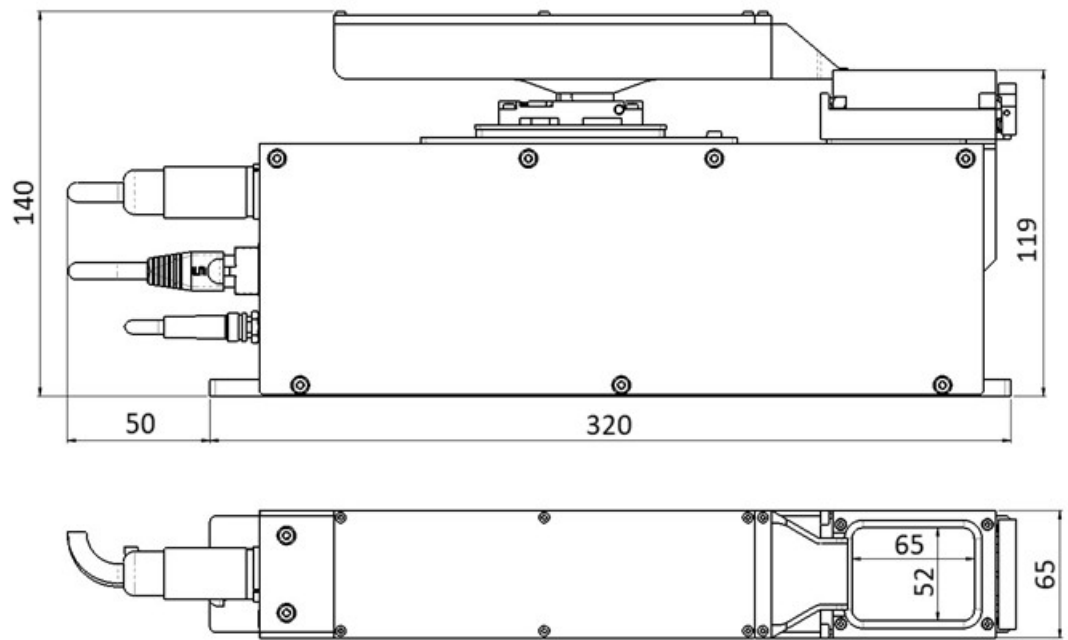

Figure 2-2: Overall dimensions of the IF-80

Additional space is needed around the IF-80 to unclamp and remove the platform with the integrated lever:

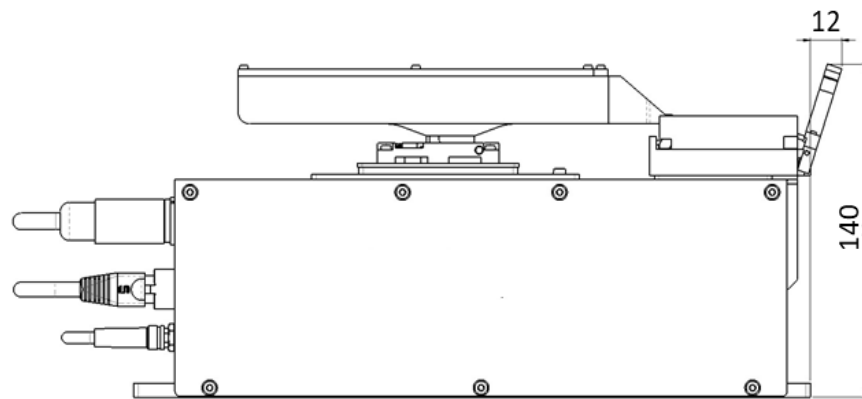

Figure 2-3: overall dimensions with "lever"



Refer to 5.2.2 *Removing the platform module* for more information on how to remove the platform.



For details of installing, refer to 3.3 *Installing IF-80*.

### 2.3.3 Visual Signals

The LEDs mounted on the unit give important information on the state of the IF-80:

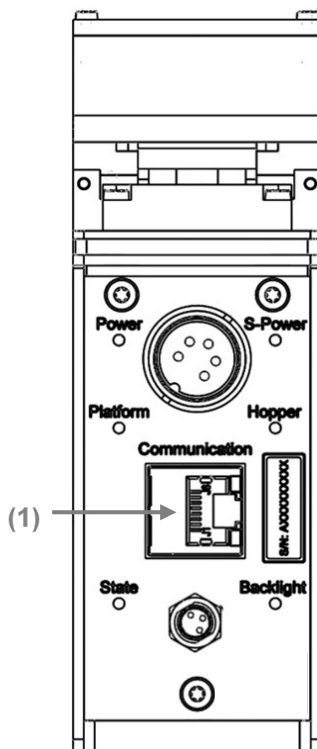

Figure 2-4: IF-80 Operation Indicator LEDs

LED	State	Meaning
Power	On	24V on Power input
S-power	On	24V on S-power input (refer to 3.6.2 <i>Power connection</i> for more information)
Platform	On	Platform vibrating
Hopper	On	Hopper vibrating
State	Blinking Time on: 100ms	System in standby
	Blinking Time on: 900ms	System in service
Backlight	On	24V on backlight Synchronization input
1	On	Communication



### 2.3.4 Maximum Permissible External Force on the Platform

The maximum permissible external force from robot hand to a point of the platform (for example, with the gripper) is:

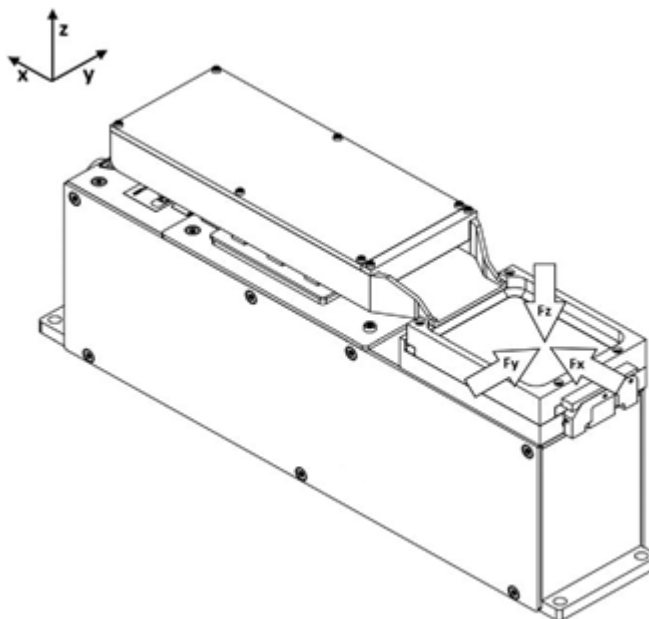

$$F_x = 3 \text{ N}$$

$$F_y = 3 \text{ N}$$

$$F_z = 5 \text{ N}$$



CAUTION

- Note that the shock or impact of the gripper may damage the surface of the platform.

### 2.3.5 Permissible Platform Weight

	IF-80
Maximum weight of the platform (without components)	150 g
Maximum weight of components (in addition to the maximum weight of the platform)	50 g

### 2.3.6 Permissible Hopper Weight

	IF-80
Maximum weight of the hopper (without components)	400 g
Maximum weight of components (in addition to the maximum weight of the hopper)	400 g

### 2.3.7 Maximum Plate Displacement

	IF-80
Maximum displacement x	±0.5mm
Maximum displacement y	±0.5mm
Maximum displacement z	±0.5mm

### 2.3.8 Plate Z Repeatability

	IF-80
Plate Z repeatability	±20 μm

## 2.4 Specification Table



- Use the parts feeder with the following specifications. Please note that the basic performance of the product will not be exhibited if it is used outside of the specifications.

### 2.4.1 Specification of IF-80

	IF-80
Typical part size *	Length of the side 3 - 8 mm
Integrated LED backlight	Select with/without backlight. Refer 2.2 Model.
Interchangeable backlight color	(green, red, blue, white, Infrared) Please refer to 4.3 Backlight for more information.
Independent vibrations in three orthogonal directions	✓
Interchangeable vibration platform	Refer to 5.2.2 for more information.
Easily removable hopper	✓
RoHS	✓
Maximum weight on the platform (components)	50 g
Maximum weight on the hopper (components)	400 g
Weight (Includes platform, backlight)	3.7kg
Protection class	IP40
Working temperature:	+5°C ~ +40°C
Humidity	30% ~ 80%max. non-condensing
Environment	cleanliness class ISO7
Safety Standard	CE Marking EMC Directive, Machinery Directive, RoHS Directive

\*: Before using parts, try to feed actual parts to the feeder and operate feeder, and check if below works.

- Parts scatter
- Parts move
- Stacked parts scatter etc.

The parts that couldnot do the above are not suitable for feeder.

### 2.4.2 Picking Surface

The maximum picking surface dimensions corresponds to the IF-80 platform size:

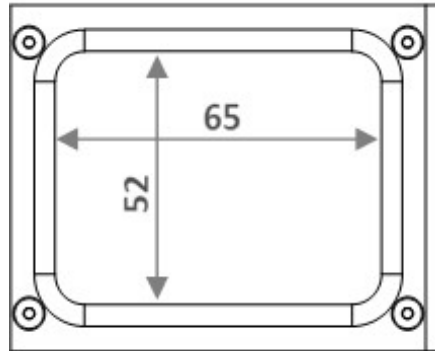

Figure 2-5: Picking surface

## 3. Environment and Installation

### 3.1 Environment

#### 3.1.1 Installation Environment

The IF-80 can be used under the following conditions:

- The IF-80 protection class is IP40 compliant
- Working temperature: + 5°C to + 40°C
- Humidity: 30% to 80% max. non-condensing



- In the case of humidity or temperature variations, note that it might affect the global performance of part feeder.

- Avoid extreme electromagnetic waves, ultraviolet rays and radiation.
- Avoid using the product in a place where the main unit or controller may be exposed to water or oil droplets.
- Clean room application: cleanliness class ISO7.



- Do not use the product in an atmosphere of corrosive gases.

#### 3.1.2 Storage Environment

The storage environment should be similar to the operating environment. In addition, you should protect the IF-80 against dust

### 3.2 Base Table

A table to secure feeder needs to be made by customers. The shape and size of table depending on purpose of your feeder system. Also, when using multiple feeders or multiple robots, note that vibration can interfere other equipment.

For details of designing of mounting table, refer to 3.5 *Installing*.

### 3.3 Installing IF-80

 CAUTION	<ul style="list-style-type: none"><li>■ The IF-80 must be mounted on a smooth, flat and solid surface. Ensure that the IF-80 is not submitted to mounting flexure. Failure to do so will degrade feeder performance.</li></ul>
--	--

To guarantee a proper behavior of the IF-80 a tight fastening to a solid underground is necessary. The following holes in the base plate of different IF-80 feeders can be used to mount it mechanically.

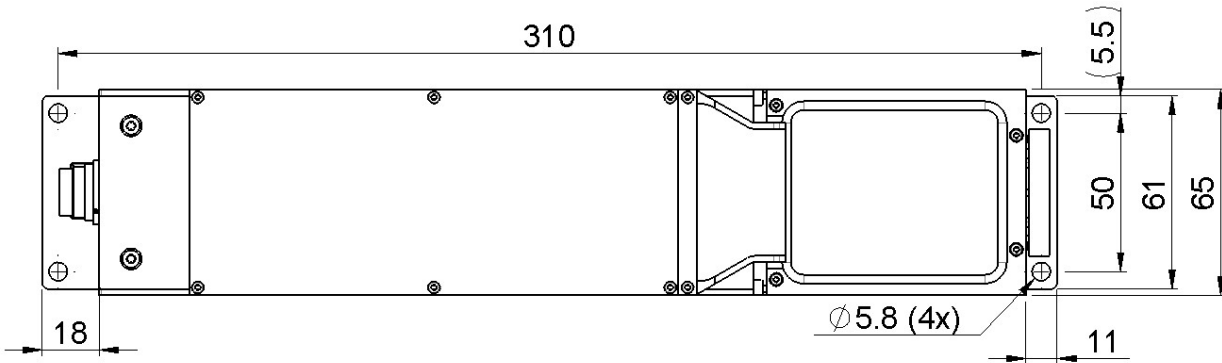

Figure 3-1: Installing dimension of IF-80

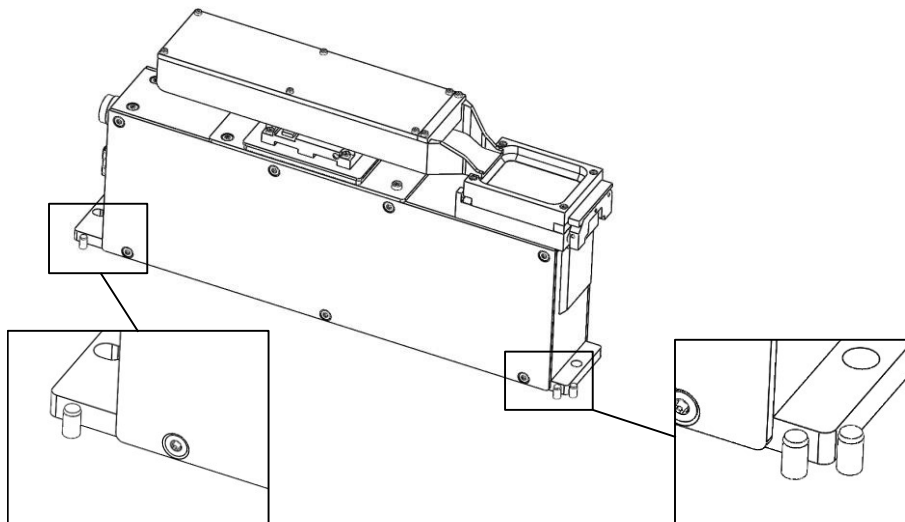



Figure 3-2: Precise positioning of the IF-80

## 3.4 Unpacking and Transportation

### 3.4.1 Unpacking

 <b>CAUTION</b>	<ul style="list-style-type: none"> <li>Keep the packaging material and the shipment box in case of need for return.</li> </ul>
---	--

 <b>NOTE</b>	<ul style="list-style-type: none"> <li>Do not remove the part feeder from its packaging until you are ready to install it.</li> </ul>
--	---

#### Step 1

Carefully open the shipping box by using a cutter.

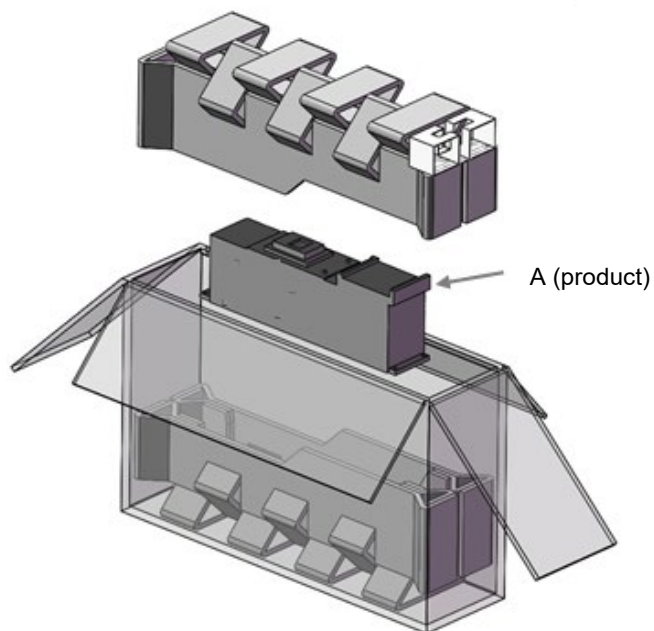

 <b>WARNING</b>	<ul style="list-style-type: none"> <li>Take care not to cut too deep or else you will damage the IF-80.</li> </ul>
---	--

#### Step 2

Verify that there is no visible damage

 <b>NOTE</b>	<ul style="list-style-type: none"> <li>If the product (A) received does not match your order, or is damaged, contact your Sales Representative.</li> </ul>
--	--

### 3. Environment and Installation

#### Step 3

Follow this manual for installing the IF-80 and start using it.

<p>NOTE</p> 	<ul style="list-style-type: none"> <li>■ Potential accessories are supplied separately in a second box</li> </ul>
---	---

Locate the identification information at the back of the product and ensure that the product you have received is the correct one (S/N).



Figure 3-3: Product information

#### 3.4.2 Packaging of the Product, Transportation and Handling

The transportation of the product must be made in accordance with the specific terms indicated on the package (top, bottom, fragile, etc.). In addition, pay particular attention to the following points:

 <p>CAUTION</p>	<ul style="list-style-type: none"> <li>■ Be careful of the weight and take care when transporting the system.</li> <li>■ Always hold the system firmly with two hands.</li> <li>■ The operator should not carry heavy shipping boxes by themselves.</li> <li>■ If the shipping box is to be left standing, it should be in a horizontal position.</li> <li>■ Do not climb on the shipping box.</li> <li>■ Do not place heavy objects, on top of the shipping box.</li> </ul>
--	--

The IF-80 is shipped in a cardboard box with the following dimensions:

	IF-80
Dimensions	500 × 330 × 130 mm
Gross weight	5 kg

Table 3-1: gross weight and dimensions of the product in packaging







## 3.5 Installation

This section is common for IF-80, IF-240, IF380 and IF-530. Refer each table when the values differ depending on the model.

### 3.5.1 Symbols and Acronyms in this Manual

This section describes symbols and acronyms.

#### 3.5.1.1 Symbols

	Wrong implementation
	Correct implementation
<b>ON</b>	Active / operating feature (moving)
	Movements
<b>OFF</b>	Passive / NOT operating feature (NOT moving)
	Perturbation / undesired vibration

### 3. Environment and Installation

---

#### 3.5.1.2 Acronyms

<b>APSO</b>	Angst + Pfister Homepage - <a href="http://www.apsoparts.com">www.apsoparts.com</a> – (see section: Antivibration Technology) APSOvib: (Initiator of the product name)
<b>ELESA</b>	Elesa Homepage ( <a href="http://www.elesa.com">www.elesa.com</a> ) – (see section: Rubber buffersw)
<b>A</b>	max. base table length
<b>B</b>	max. base table width
<b>c</b>	distance between feeders
<b>ØD</b>	diameter of the round buffer APSOvib
<b>G</b>	screw diameter
<b>H</b>	height of the round buffer APSOvib
<b>c<sub>z</sub></b>	spring constant of the round buffer APSOvib; compression in Z direction (axial direction)
<b>F<sub>z</sub></b>	max. allowed compressive force of the round buffer APSOvib
<b>L</b>	Length of male screws
<b>M</b>	mass
<b>N/A</b>	not applicable
<b>Qty.</b>	quantity
<b>Ref.</b>	reference
<b>s</b>	Depth of female screws

**3.5.2 Installing Part Feeding**

To ensure normal vibration behavior the Part Feeding must be correctly installed on a base table specifically defined for the application. An incorrect installation of the Part Feeding could compromise the performances of the product.

**3.5.2.1 Position of Part Feeding to installing on the table and specification of the table**

The Part Feeding must be installed either on a rigid base table screwed to the ground or on a not secured but heavy base table. For the second application the mass [M] and the dimensions [A × B] of the base table must be large enough to absorb the vibrations generated by the feeder.

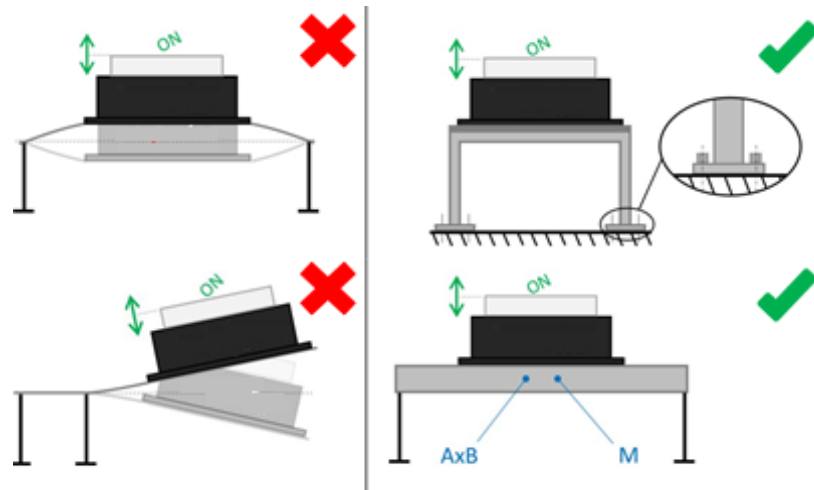

**3.5.2.2 Installing Part Feeding on the table**

The Part Feeding must be properly installed on the base table.

<p>NOTE  </p>	<p>■ About number of screws and size of screws when installing on the base table, refer to 3.5.5.2 <i>Specification of Screw</i>.</p>
--	---

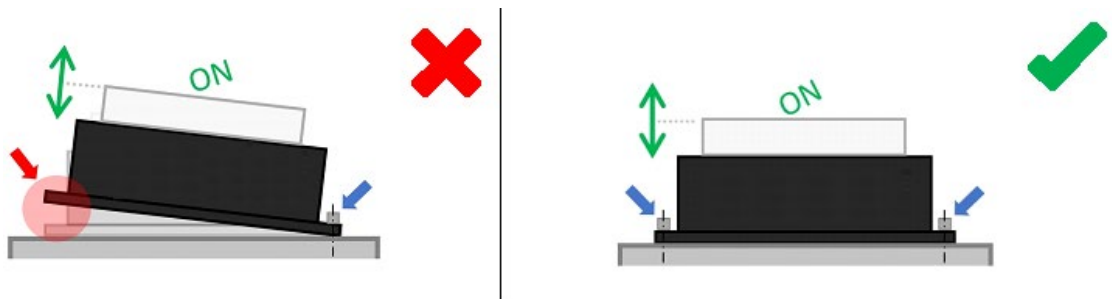

### 3.5.3 Vibration Decoupling

Incorrect assembly of Part Feeding, camera, robot, and hopper may compromise final system performance. To ensure the normal behavior of a system, it is necessary to avoid that all the involved devices can interfere with each other.

NOTE



- Hoppers are provided with vibration isolators so that hopper vibration is not transmitted to other peripherals.

#### 3.5.3.1 Decoupling of Moving Devices

If several moving devices are assembled in parallel, and close to each other, it is necessary to “decouple the vibrations”, to avoid that behavior of any product is disturbed by the movement of others.

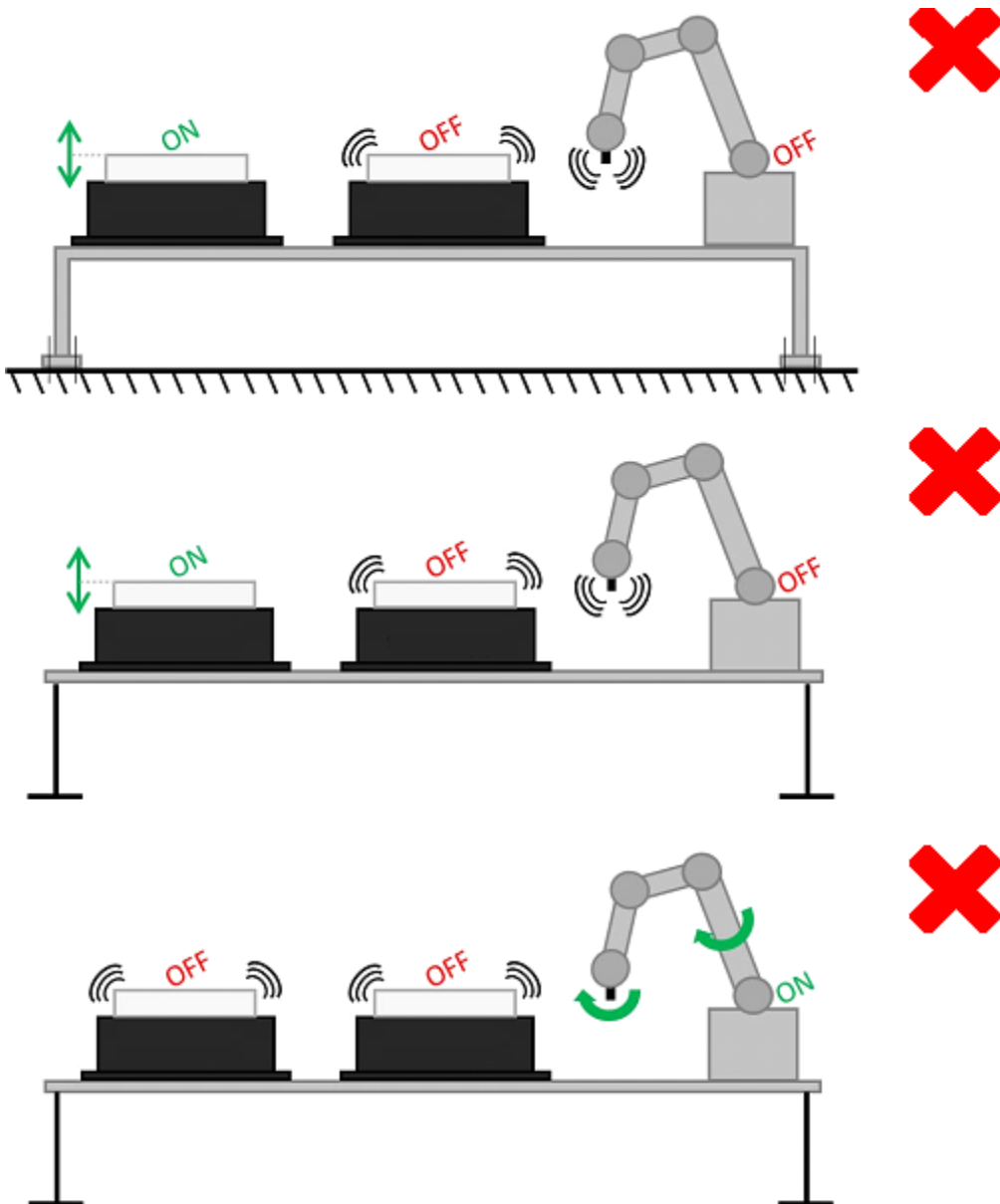

It is recommended that each device be equipped with a separate base table to prevent vibration interference. When you can not place it, you can use a part that has Antivibration Technology to isolate vibration. (e.g. vibration isolators [①])

NOTE 	<ul style="list-style-type: none"> <li>■ Vibration isolators solution is only applicable to IF 240, 380 and 530.</li> </ul>
---	---

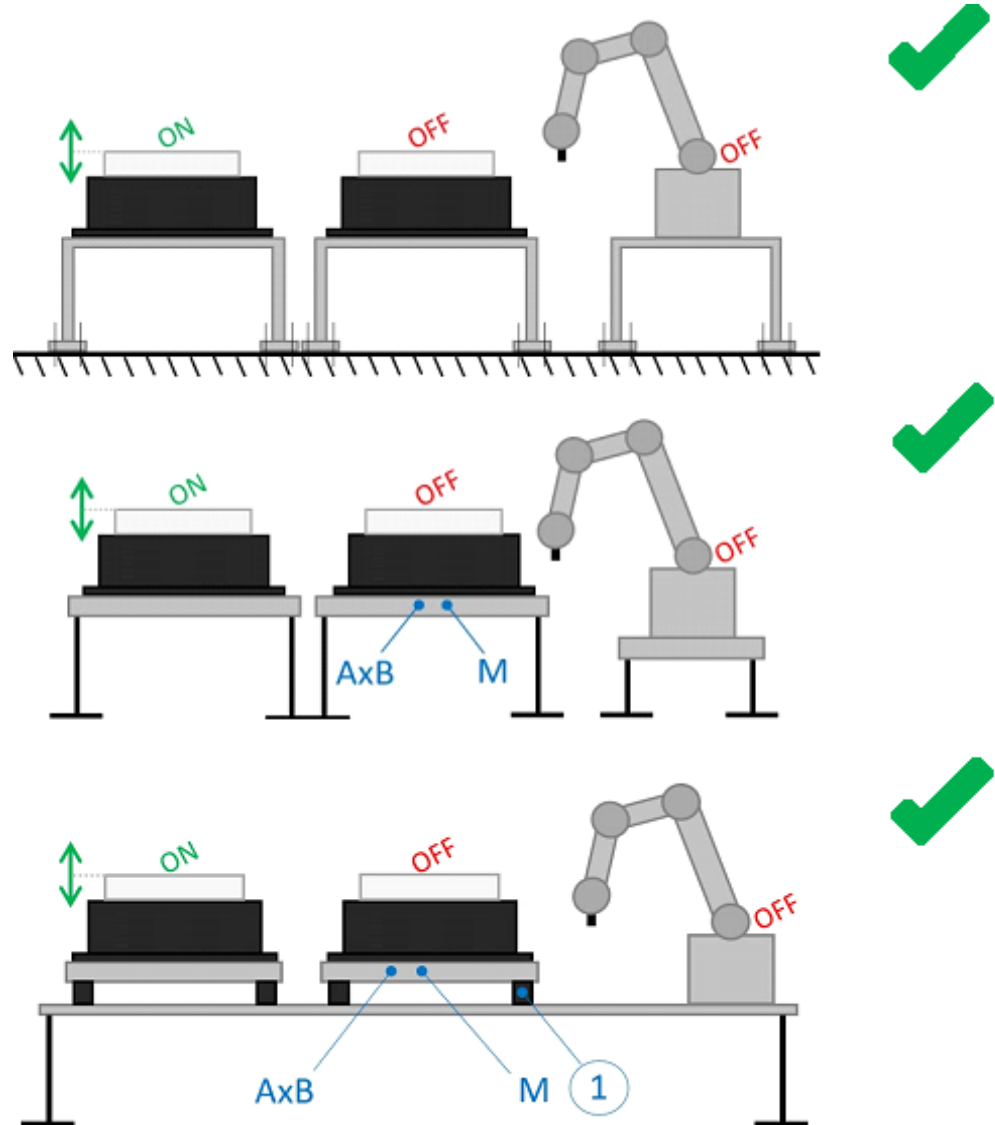

For the mass [M] and dimensions [A × B] of the base table, refer to 3.5.5.1 *Specification of Base Table*.

For the vibration isolators [①], refer to 3.5.5.3 *Specification of Vibration Isolators*.

NOTE 	<ul style="list-style-type: none"> <li>■ Increasing the mass of the base table to avoid the integration of the vibration isolators does not ensure that the spread vibrations will be completely dampen-out.</li> </ul>
---	---

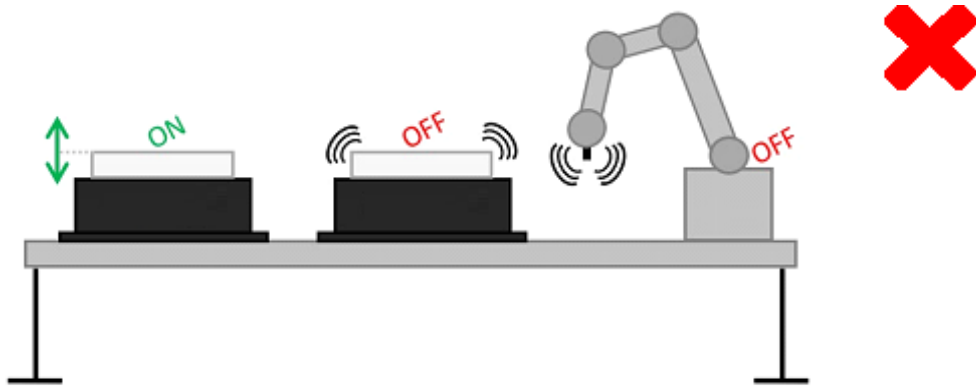

3.5.3.2 Decoupling the Camera

It is important that the camera is not perturbed by the vibration of the feeder or by any other moving device. If the vision system is disturbed by residual vibrations, the coordinates sent to the robot will not be reliable, thus compromising the precision of the whole system.

Therefore, it is recommended not to install feeders and cameras on the same support. When this solution is not applicable, be sure to mount the camera on a rigid and heavy enough base table to prevent back-feeding of vibrations into surrounding devices.

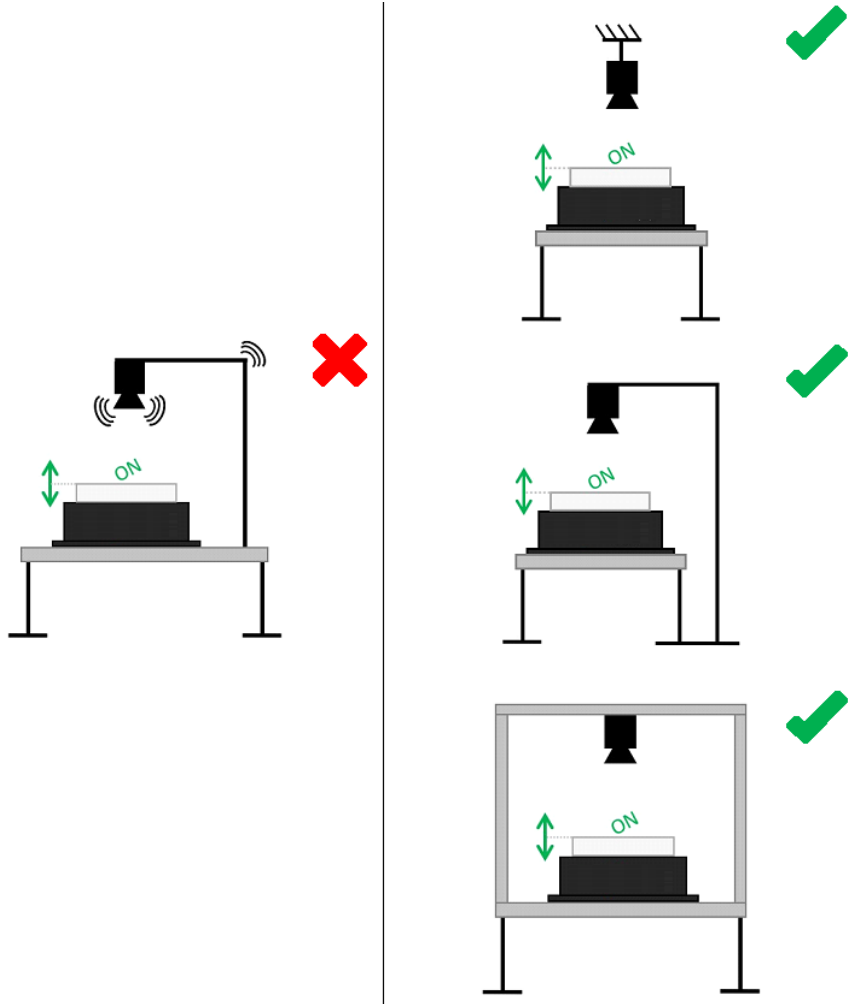

### 3.5.4 Minimal Distance Between Part Feeding

When two or more feeders are installed close to each other, the movement of the active device can excite the passive one. It is therefore recommended to install the feeders at enough distance to prevent them from disturbing each other.

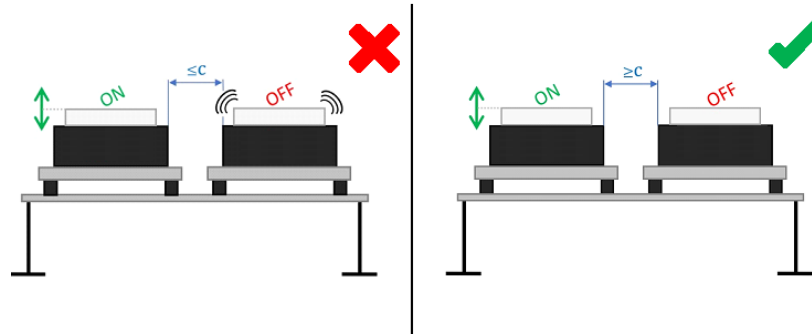

The minimal distance between Part Feeding, refer to 3.5.5.4. *Minimal Distance Between Part Feeding.*

**3.5.5 Technical Data Tables**

This chapter contains the technical parameters required to properly install the part feeding.

**3.5.5.1 Specification of Base Table**

	IF-80	IF-240	IF-380	IF-530
M – [Kg]	≥ 10	≥ 40	≥ 200	≥ 250
A – [mm]	≤ 600	≤ 600	≤ 1000	≤ 1200
B – [mm]	≤ 150	≤ 350	≤ 500	≤ 750

Table 3-2: Specification of Base Table

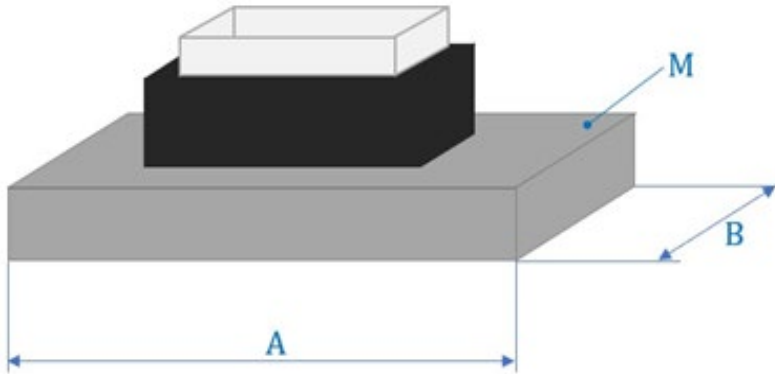

<p>NOTE</p> 	<ul style="list-style-type: none"> <li>■ The thickness of the base table must be calculated basing on requirements resumed in Table 3-2: Specification of Base Table.</li> <li>■ Dimension the base table so that the minimum mass [M] requirement is met.</li> </ul>
---	---

**3.5.5.2 Specification of Screw**

	IF-80	IF-240	IF-380	IF-530
Quantity of screws	4	4	4	4
Screw ø	M5	M6	M8	M8

Table 3-3: Specification of Screw



## 3.5.5.3 Specification of vibration isolators

	IF-240	IF-380	IF-530
APSO *1	12.2034.0103	12.2034.0293	12.2034.0353
$\varnothing D$ – [mm]	16	40	50
H – [mm]	20	40	50
cz – [N / mm]	50	180	190
Fz – [N]	120	690	1000
Qty. – [-]	4	4	4

ELESA *2	411771	412021
	DVA.2-15-20-M4-10-55	DVA.2-50-45-M10-28-55
$\varnothing D$ – [mm]	15	50
H – [mm]	20	45
G – [mm]	M4	M10
L – [mm]	10	28
S – [mm]	4	10
cz – [N / mm]	47	182
Fz – [N]	234	2046
Qty. – [-]	4	4

Table 3-4: Specification of vibration isolators

 <b>CAUTION</b>	<ul style="list-style-type: none"> <li>Make sure that total mass of the Part Feeding, base table and components are not exceeding the max. allowed compressive force of the round buffers [Fz]. If the total mass exceeds the max. allowed compressive force, select new round buffer.</li> </ul>
---	---

## Vibration isolator (round buffer)

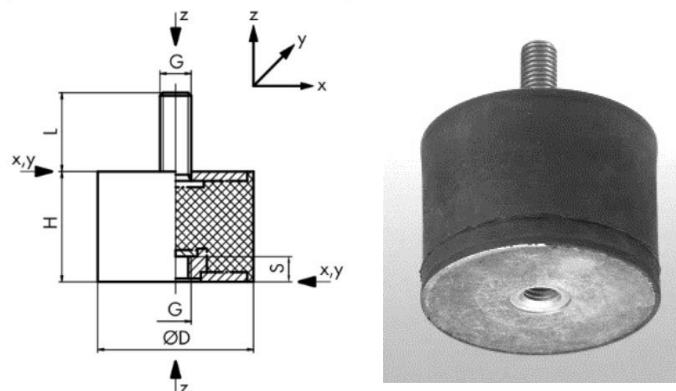
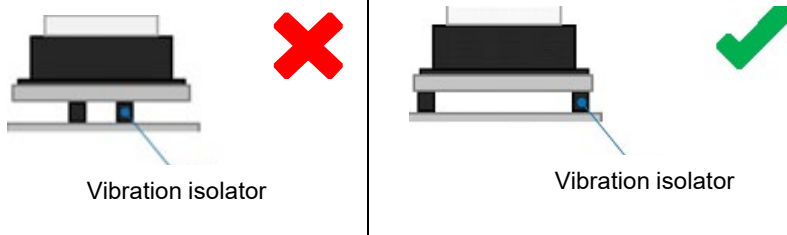

Figure 3-4: Vibration isolator (round buffer)

Position of Vibration isolator



\*<sup>1</sup> Angst + Pfister - [www.apsoparts.com](http://www.apsoparts.com) – (section: Antivibration Technology; APSOvib)

\*<sup>2</sup> Elessa - [www.elesa.com](http://www.elesa.com) – (section: Rubber buffers)

3.5.5.4 Minimal Distance Between Part Feeding

	IF-80	IF-240	IF-380	IF-530
c – [mm]	≥ 10	≥ 10	≥ 30	≥ 30

Table 3-5: Minimal Distance Between Part Feeding

## 3.6 Connecting Cable

### 3.6.1 Overview

The IF-80 is a standalone module with its own controller. The electrical interfaces of the IF-80 are located on the rear panel of the product:

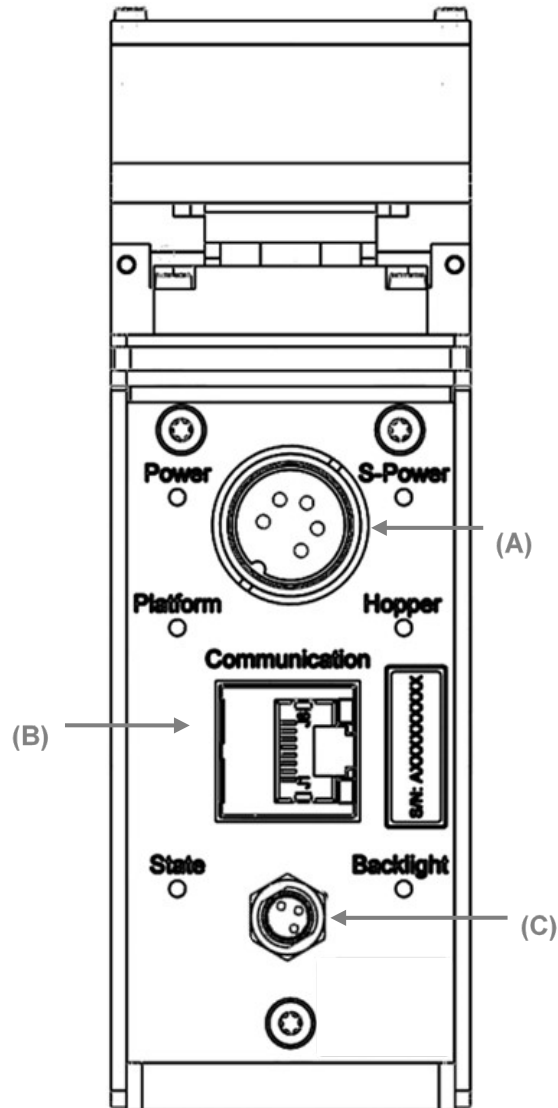



Figure 3-5: Electrical interfaces of the IF-80

- A Power connection
- B Ethernet connection (RJ45)
- C Backlight synchronization

3.6.2 Power Connection

 <b>CAUTION</b>	<ul style="list-style-type: none"> <li>■ Before supplying power to the part feeder, check that the distribution voltage is the same as the nominal voltage.</li> <li>■ Never disconnect the power cables when the unit is on. Always turn the machine off and then cut the power.</li> <li>■ Use PELV (protected extra-low voltage) nominal voltage.</li> <li>■ Unplug the main power plug when plugging / unplugging the cord.</li> </ul>
---	--

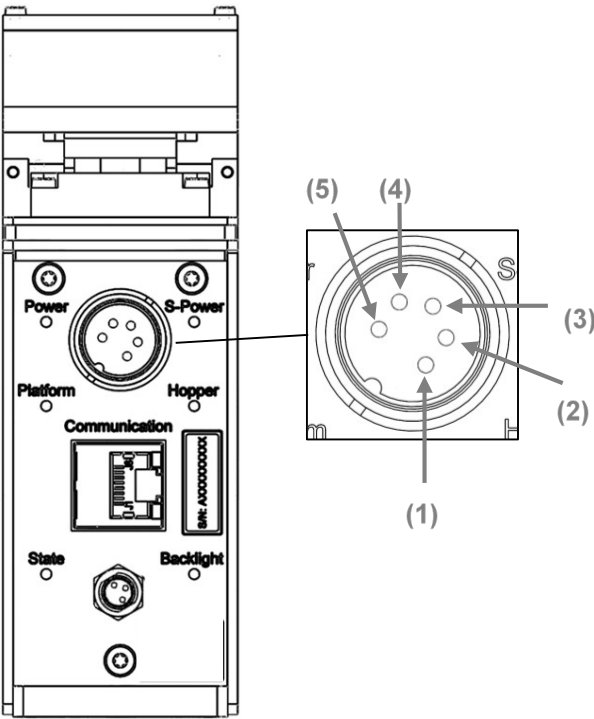



Figure 3-6: Power connection

Pin	Signal description
(1)	24VDC PELV S-Power
(2)	0V GND S-Power
(3)	24VDC PELV Power
(4)	0V GND Power
(5)	EARTH

Connector type (on IF-80 side): M16, 5 Poles, male

<b>NOTE</b> 	<ul style="list-style-type: none"> <li>■ In case of all functions working simultaneously (vibration, backlight, hopper), the current increases to 6A</li> </ul>
--	---

Characteristic	Value
Voltage	+ 24VDC ± 5%
Current Power	5 A
Current S-Power	1 A

NOTE 	<ul style="list-style-type: none"> <li>The backlight receives power supply by S-Power. Cutting this S-Power ensures that the backlight stays OFF. (e.g. to secure IR backlight danger).</li> </ul>
	<ul style="list-style-type: none"> <li>When operating the feeder, connect both Power and S-Power to power supply.</li> </ul>

The following connection schematic shows the methods to connect to the IF-80 depending on if your application requires an external relay to ensure that the backlight is safely switched off or not.

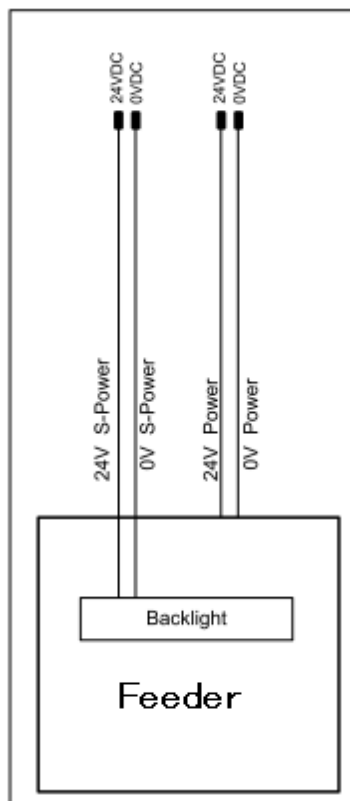

Figure 3-7:  
Power connection without safety relay

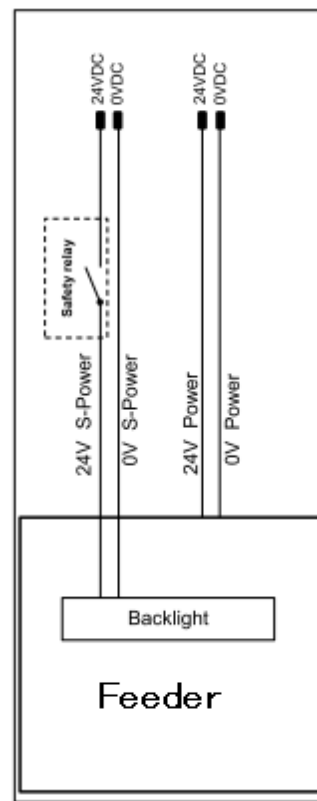



Figure 3-8:  
Power connection with safety relay

NOTE 	<ul style="list-style-type: none"> <li>Both Power and S-Power can be connected to a single power supply or to two different power supplies.</li> <li>The 0 V power supply and the 0 V S-power supply are internally connected in the feeder.</li> </ul>
---	---

short-circuit current rating:

	SCCR
Power	40 A
S-Power	40 A

### 3.6.3 Communication

The communication with the IF-80 is established by a standard Ethernet communication via RJ45 port (A)

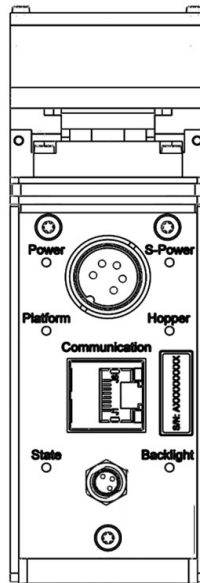

Figure 3-9: Ethernet connection RJ45

Characteristic	Value
Default IP address	192.168.0.64
Default subnet mask	255.255.255.0
Port	4001
MAC address	Can be read by ARP request





For more information on the procedure to restore the default IP address, please refer to 5.3.2 *Resetting IP address*.

## 4 Option

### 4.1 Platform

#### 4.1.1 Platform Type

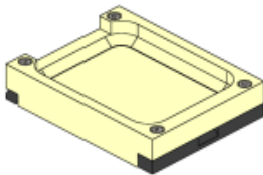
In order to improve the availability of certain components on the surface of the feeder, it is possible to structure the platform surface. EPSON offers various types of platforms including Flat, Anti-Stick and Anti-roll. Custom platforms with slots, holes or pockets must be designed and fabricated by the customer.

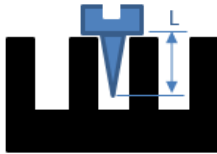
Platform type	Example-picture	Example-drawing	Advantage
Flat		 Ex: Bolts	This type of platform can be used for a large variety of components with a flat surface allowing a stable resting position.
Slots (deep)		 Ex: Screws, Rivets	Screw type components can be fed in vertical position when the platform is structured with deep grooves. L max=4mm





NOTE

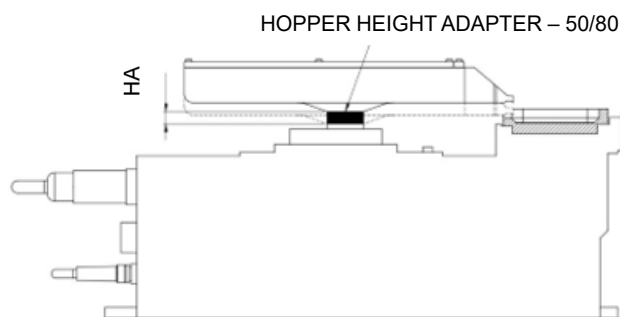

- L can be increased by a value HA by using the optional “HOPPER HEIGHT ADAPTER”, and by realizing a special platform for this configuration.

HA max = 7.5mm

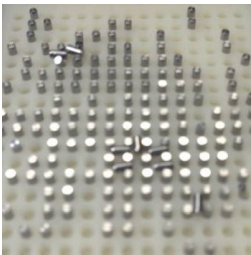
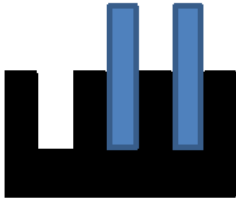

Platform type	Example-picture	Example-drawing	Advantage
<p>Grooves (wide) (Anti-roll)</p>		 <p>Ex: Cylinders, Needles</p>	<p>Wide grooves are useful when cylindrical components are fed. They reduce the stabilizing time significantly after component displacements on the platform surface. (stop the components from rolling on the surface)</p>
<p>Grooves (narrow) (Anti-stick)</p>		 <p>Ex: Thin washers</p>	<p>Narrow grooves are necessary to reduce surface contact especially for flat and light components. This reduces adhesion forces and improves the pick-performance of the robot.</p>
<p>Holes</p>		 <p>Ex: Pins</p>	<p>Holes are useful when cylindrical components are to be fed and presented upright.</p>



### 4.1.2 Standard Platforms Usage

**Flat:** Parts that have a stable orientation when seated on a tabletop can use a Flat Platform. The parts should have a stable equilibrium and fast stabilization time after vibration. For high-mix low-volume production, most applications use a Flat Platform.

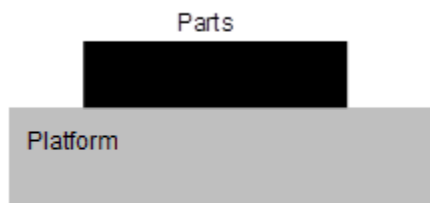

Cross-sectional view

The platforms supplied by Epson meet a flatness and parallelism specification to ensure picking precision as summarized in the table below.

	IF-80
Flatness of the surface [mm]	0.1
Parallelism between surface and reference [mm]	0.1

**Anti-Stick:** Anti-stick platforms have narrow grooves to reduce surface contact for flat and light components. This reduces friction forces and improves the component movement on the platform surface. Parts that do not spread well because of kinetic friction (sliding friction or dynamic friction) are a good candidate for Anti-Stick platforms.

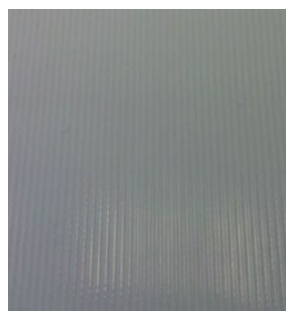

Surface

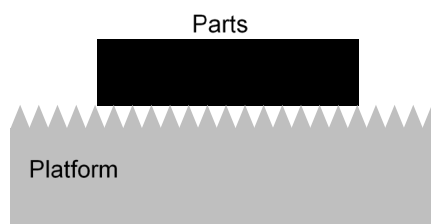

Cross-sectional view

	A	B	C	D
IF-80	0.4	0.4	0.2	90

Geometry of standard anti-stick platform for IF-80

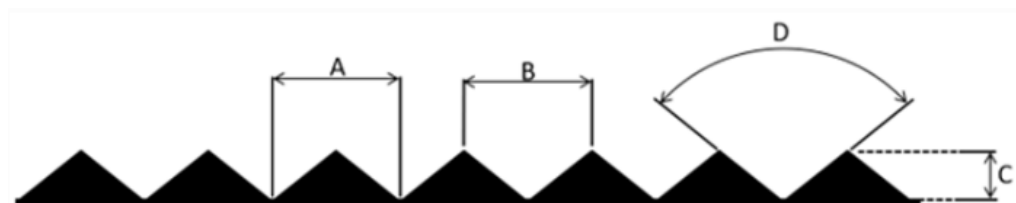

**Anti-Roll:** Anti-Roll platforms have a machined, structured surface that can stabilize parts that tend to roll on the platform. The Anti-Roll platform is particularly useful when

cylindrical components are being fed. The Anti-Roll platform reduces the stabilization time by preventing the parts from rolling.

	A	B	C	D	Suitable for Parts
IF-80	1.25	1	0.5	90	ø 0.7mm – ø 1.5mm
IF-80	2.75	2.5	1.25	90	ø 1.5mm – ø 3.5mm

Geometry of standard anti-roll platform structure for IF-80

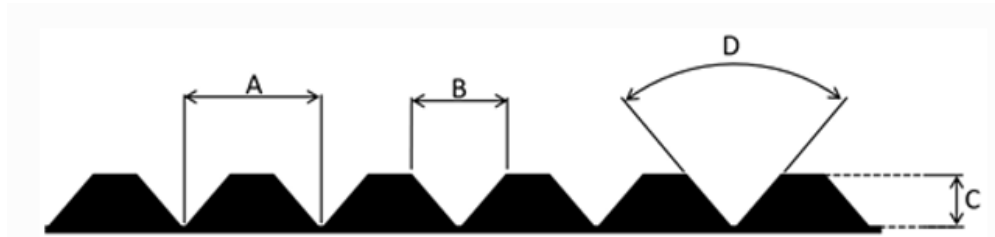

For more information on custom platforms, refer to the the Advanced section of the *Part Feeding Introduction Manual* called “2.2 Custom Platforms”



For model number of Plate provided by Epson, refer to 6.2 *Plate (series: IF-80)*.

### 4.1.3 Plate Fixation Kit

In the case of custom platforms, a plate fixation kit can be ordered from Epson.

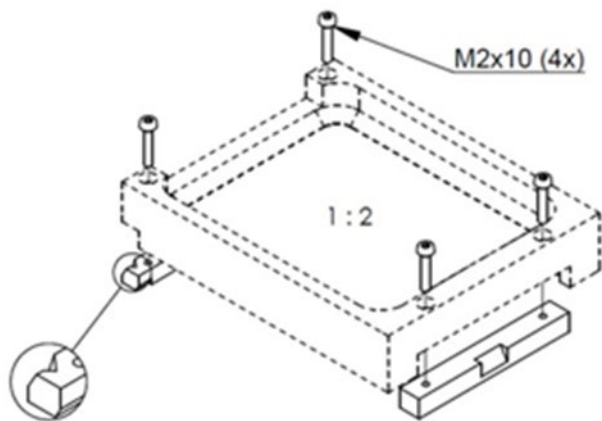

The flat platform can be used for a large variety of components, mainly components with a flat surface allowing a stable resting position.

The IF-80 platform is available in option.

Product name	Specification	Model number
PLATE FIXATION KIT - 80	Platform kit	R12NZ9016M

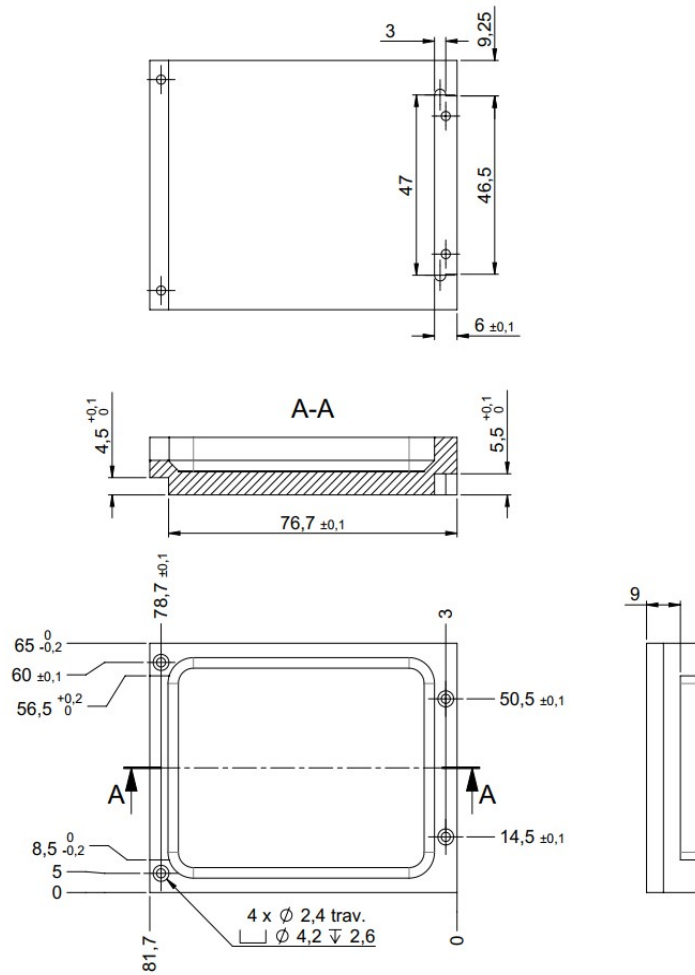

Mechanical interfaces of the platform for IF-80

#### 4.1.4 Dimension of Platform

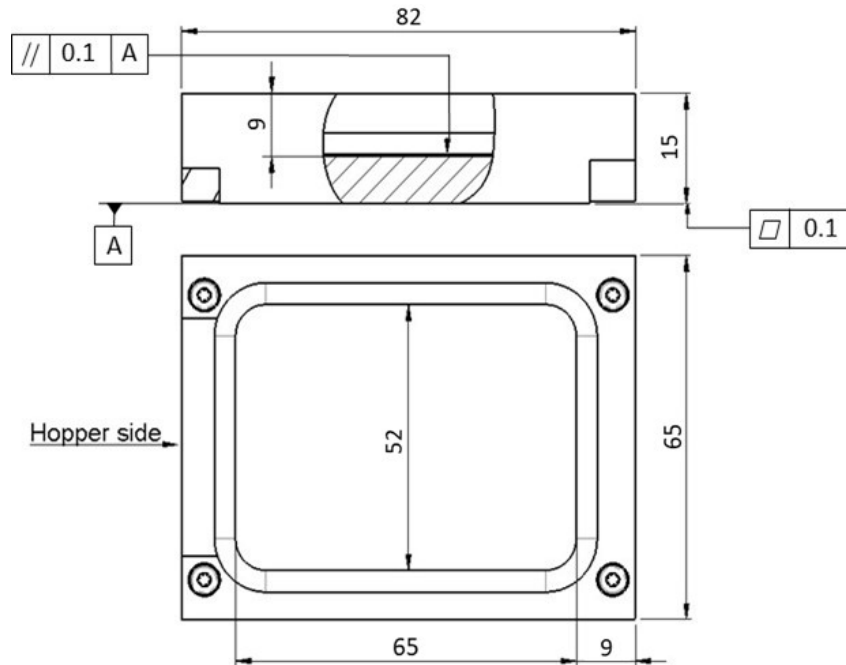

Figure 4-1: Overall dimensions of the platform

#### 4.1.5 Platform with Purge

A platform with purge function is available in option with the IF-80.

The purge option consists in a platform (A) with a special geometry, which allows the components to be evacuated in a dedicated box (B).

The box can be easily removed by the operator without tooling.

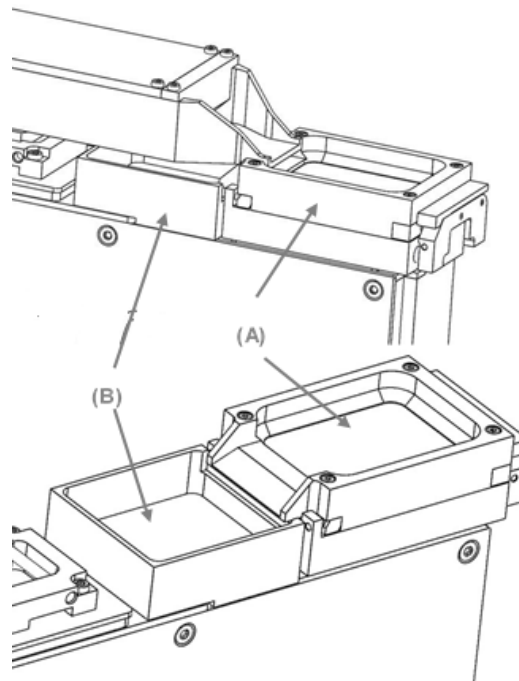

Figure 4-2: Purge option

## 4.2 Hopper

A hopper is available in option.

It is delivered with a separate cover, a retaining dam and screws, which can be assembled by customer if needed.

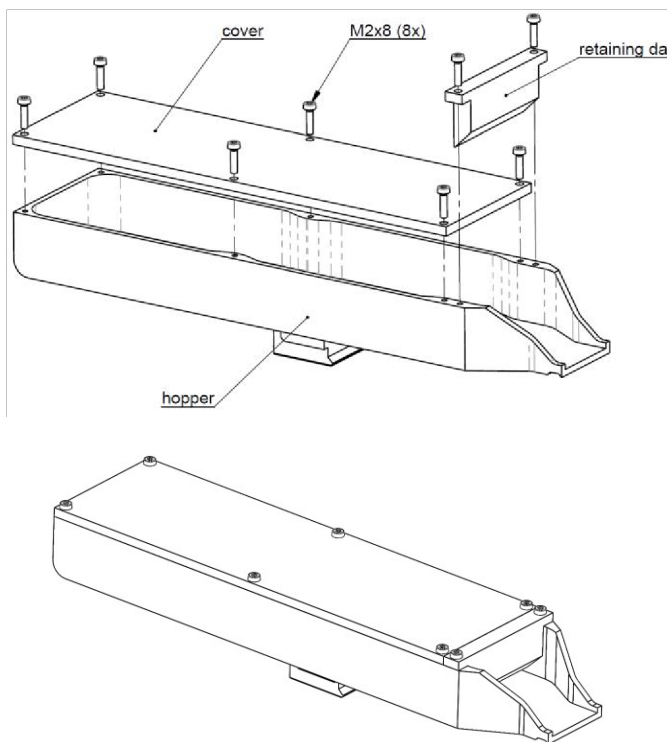

Figure 4-3: Hopper

Product name	Specification	Model number
160cm <sup>3</sup> HOPPER - 80	160cm <sup>3</sup> Hopper	R12NZ9016F
160cm <sup>3</sup> HOPPER MEDICAL - 80	160cm <sup>3</sup> Hopper/ FDA*	R12NZ9016G

\* We use materials which conformed FDA (Food and Drug Administration).  
(FDA 21CFR177.2470 & 21CFR178.3297)

## 4.3 Backlight

### 4.3.1 Color Options

The following backlights are available as options.

Color	Wavelength
Blue	465 nm
Green	520 nm
Infrared	880 nm
Red	640 nm
White	6500 K

If this option is ordered at the same time with the IF-80, it is delivered mounted in the feeder.



For more information on the backlight color and the procedure to exchange the backlight, please refer to 5.3.1 *Exchange of the backlight.*



For model number of backlight, refer to 6.5 *Backlight (series: IF-80).*



WARNING



- Infrared light (IR) is invisible to human eyes. NEVER use the infrared light without the platform (A) secured. When the platform (A) is attached to the part feeding, the system does not pose a risk for the operator.

### 4.3.2 Selecting a Backlight Color

For most of the application, the color of the lighting does not matter, especially for opaque parts. For this reason, we advise the standard red color.

It may be difficult to see translucent parts if their color is close to the color of the backlight. The part may merge a bit with the background. This may be the case even with plastic parts that looks opaque to the eye.

In the example below, when illuminated with a red backlight, the contrast between the yellow clips and the background is compromised (even if the clips look opaque with ambient light).

When illuminated with a blue backlight, the same part will have a much higher contrast against the background. This is because the blue color is the complementary color of the yellow and is therefore better absorbed than the red one.

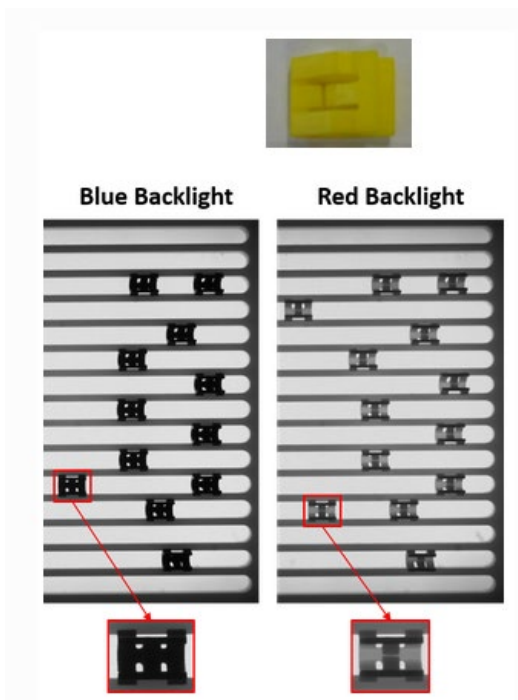

This is because the yellow color is closer to the red than to the blue in the chromatic circle.

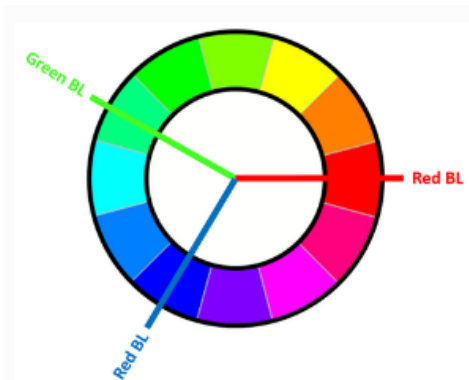

To maximize the contrast, the color of the backlight should be at the opposite of the color of the part.

### 4.3.3 IR Backlight

IR light can be dangerous for the human sight if no protection (filters) are used on the machine fences. Thus, we advise to use the IR backlight only if it is really required, for example in the following situations:

- Different colored parts that are mixed together may appear similar regardless of their color.
- Translucent parts may appear opaque with a near IR.

### 4.3.4 Backlight Overheat Prevention



- The IF-80 feeder backlight can overheat and become broken if the duty cycle for the backlight is greater than 33%.
  - The feeder automatically turns off the backlight after a timeout.

To prevent damage caused by overheating of the backlight, the backlight is controlled not to turn on continuously:

- EPSON RC+ enforces a cool off delay if the backlight was turned off due to a timeout after the user had turned on the backlight manually.
- During vision sequence operation, the backlight is turned on, the sequence runs, then the backlight is turned off immediately.

When the user manually turns on a backlight for the IF-80 from EPSONRC+, then after a delay, the [Feeder \* Backlight Cooling Delay] dialog is displayed. \* indicates the feeder number.

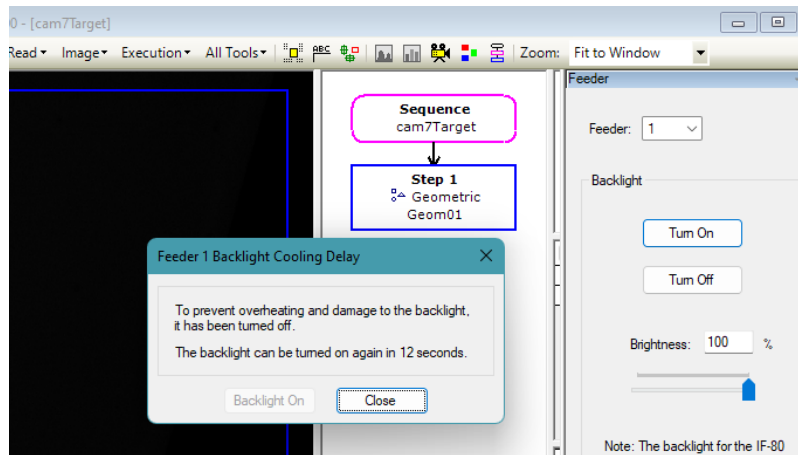

It shows a countdown in seconds for when the backlight can be turned on again. After the cool off delay, the <Backlight On> button is enabled, and the user can turn on the backlight again. The user can also click the <Close> button to close the dialog without waiting for the cool off delay. In the screenshot above, you can see that 12 seconds is remaining – it will continue to count down until 0, then the message is changed and the <Backlight On> button is enabled, as shown in the next screenshot.



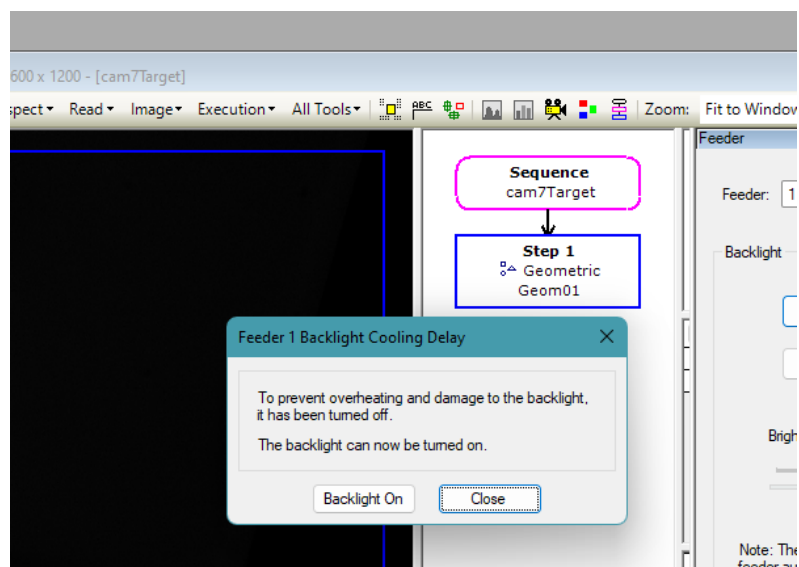

If the user clicks <Close> button and then tries to turn the backlight on again before the cool off delay is reached, then the [Feeder \* Backlight Cooling Delay] dialog is displayed again showing the remaining cool off seconds.

If there are multiple IF-80 feeders in the system and multiple backlights are turned on, then the [Feeder \* Backlight Cooling Delay] dialog will open for each backlight that requires it.

When running a vision sequence or object from the EPSON RC+ Vision Guide window, the backlight is turned on, the image is grabbed, the backlight is turned off and the video is temporarily frozen. Freezing the image allows the user can see the image even though the backlight has been turned off. The user can click on the video area to switch back to live video.

## 4.4 Cables

The following cables are available as options.

Product
Power Cable (5m)
Ethernet RJ45 cable (5m)



- All these cables are NOT adapted for cable carriers (cable tracks).

Product name	Specification	Model number
POWER CABLE 80/240	Power cable	R12NZ9016K
RJ45 CAT5e -SF/UTP 5m GREY CABLE	Ethernet cable	R12NZ9016L

# 5. Maintenance and Component Replacement

## 5.1 Safety Precautions

### 5.1.1 General Safety Precautions

 WARNING	<ul style="list-style-type: none"><li>■ Failure to observe the instructions may result in electrocution or serious injury due to electric shock.</li><li>■ Power down the system and unplug it from the mains before any kind of maintenance.</li><li>■ Do not pour water or any other liquids onto the product. Spraying water over the product, washing it with water or using it in water may cause the product to malfunction, resulting in injury, electric shock, fire, etc.</li></ul>
--	--

 WARNING	<ul style="list-style-type: none"><li>■ There are no user serviceable parts inside the product. Contact the supplier of your region or your local supplier for maintenance. In cases of nonconformity, the product guarantee will expire.</li></ul>
--	---

 CAUTION	<ul style="list-style-type: none"><li>■ Do not operate the system when it is damaged. Please ensure before use that there are no visual defects.</li></ul>
---	--

### 5.1.2 Specific Warnings

 CAUTION	<ul style="list-style-type: none"><li>■ Be sure that the platform is unloaded before any kind of maintenance.</li></ul>
--	---

## 5.2 Maintenance



- For any kind of maintenance, always use Epson products.

### 5.2.1 Periodic Maintenance Schedule

The IF-80 is virtually maintenance-free. However, simple inspections should be done at regular intervals to ensure optimum performances, and safety operating of your product.

	Item	Period	Reference
General	Cleaning of the machine	Week	
	Visual check of electrical harness	Year	
	Visual check and cleaning of the plate	Week	Section 4.2.3
Specific process	It is the customer's responsibility to schedule the maintenance of his specific process	/	/
Backlight	Visual check	Month	

Table 5-1: Periodic maintenance schedule

NOTE



- The information given in “Table 5-1: Periodic maintenance schedule” is only a guideline. Maintenance and times must be modified in accordance with your particular system, its operating environment and the amount of usage.

5.2.2 Removing the Platform Module



- Be sure that the backlight is off before removing the platform module. Failure to follow this instruction may cause permanent damage to the backlight.

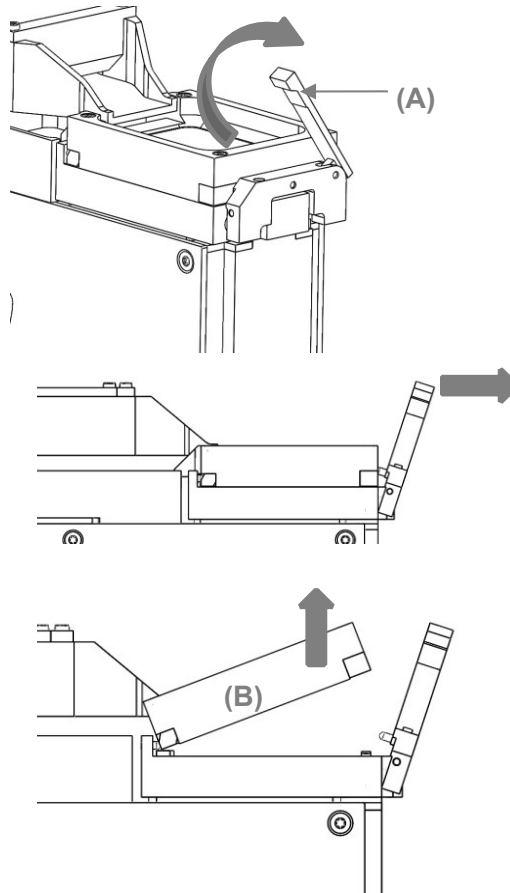

Figure 5-1: Remove the platform

Step 1 Turn the lever (A) clockwise and pull it forward.

Step 2 Remove the platform (B).

## 5.2.3 Control and Cleaning of the Platform



- If the surface is damaged so as to obstruct vision or the behavior of parts, its replacement must be preceded.  
For more information about maintenance parts, please contact the supplier of your region.

Material needed:

- Lint-free cloth
- Isopropanol alcohol

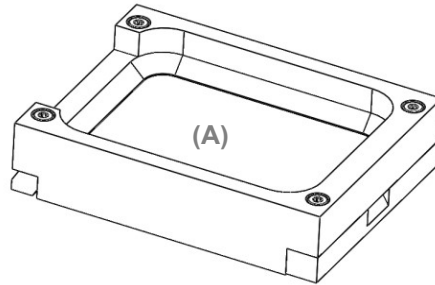

Figure 5-2: Platform

Step1

Control the surface state of the platform (A) and be particularly careful of the following points:

- Dirt or spotted surface
- Oily or greasy surface

Step2

Clean the surface of the platform.

### 5.3 Component Replacement

For a list of the components which can be replaced directly by the customer, please contact the supplier of your region. For any other repair, the product must be returned to the manufacturer.



CAUTION

- For any kind of replacement, always use Epson products.

#### Replaceable parts

Parts name	Code
GREEN BACKLIGHT - 80	R12NZ9016Q
RED BACKLIGHT - 80	R12NZ9016R
BLUE BACKLIGHT - 80	R12NZ9016T
WHITE BACKLIGHT - 80	R12NZ9016U
INFRARED BACKLIGHT - 80	R12NZ9016V

## 5.3.1 Exchange of the Backlight



- Be sure that all power sources and other cable connectors to the unit are disconnected before changing the backlight.

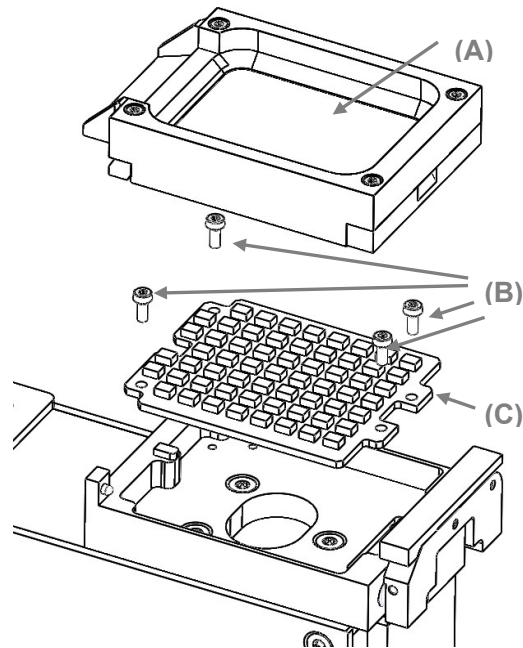

Figure 5-3: Exchange of the backlight

Step 1 Remove the platform module (A).



For more information on how to remove the platform, refer to 5.2.2 “*Removing the platform module.*”.

Step 2 Remove the four screws (B).

Step 3 Remove the backlight (C).

Step 4 Place the new backlight.

Step 5 Screw the four screws (0.2 N·m).

Step 6 Remount the platform module.

### 5.3.2 Resetting IP Address

The following procedure explains how to reboot the IF-80 so that it uses the default IP address, subnet mask and TCP port number to be able to modify the IP address, subnet mask and TCP port number when they are unknown and cannot be found. Following this procedure, you are able to connect to the IF-80 with default parameters and then modify parameters as desired.

#### Step 1

Remove the hopper.

Unscrew the 4 screws (A) and remove the cover (B).

Use a torx key size 10.

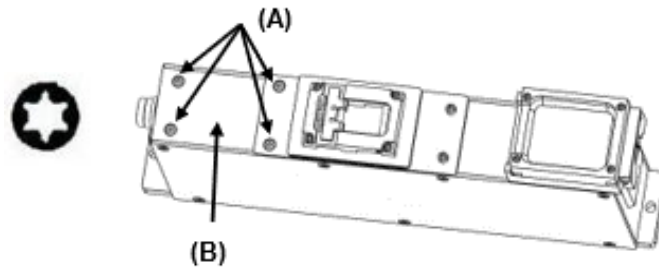

#### Step 2

Place selector 1 in “on” Position (C)

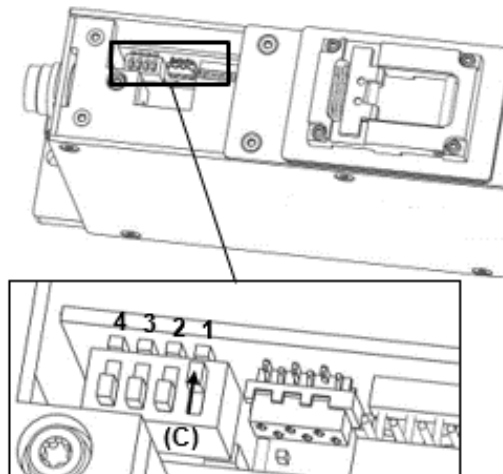

#### Step 3

Disconnect and reconnect the power cable. (or switch off and switch on the power on the IF-80.)

The IF-80 will take the default parameters by the new startup:

IP: 192.168.0.64

SubnetMask: 255.255.255.0

TCP Port: 4001



## Step 4

Parameters in memory can now be modified from the EPSON RC+, go to the [Setup]-[System Configuration]-[Controller]-[Part Feeding] page  
For more details, refer to *Software 2.1 System Configuration*.

## Step 5

When parameters are defined as desired, replace selector 1 in position (D).

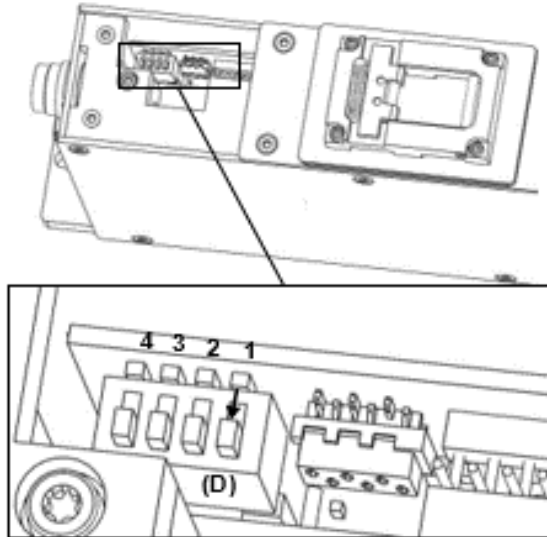

## Step 6

Disconnect and reconnect the power cable. (or switch off and switch on the power on the IF-80.)

The IF-80 will take the parameters defined by the new startup.

## Step 7

Replace the cover (B) and screw the 4 screws (A).

Use a torx key size 10. (0.9 N·m)

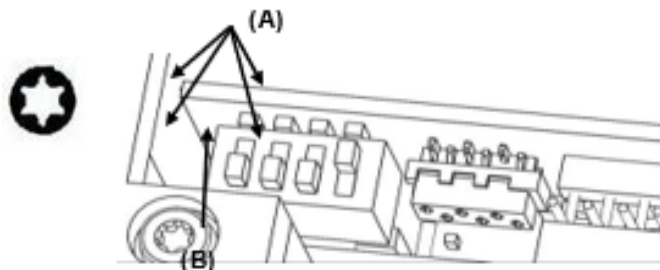

## 6. Option Part List

### 6.1 Feeder (series: IF-80)

Product name	Specification	Model number
IF80 no Light	IF80 (no backlight)	R12NZ9015B
IF80 RED	IF80+backlight: Red	R12NZ9015C
IF80 WHITE	IF80+backlight: White	R12NZ9015D
IF80 GREEN	IF80+backlight: Green	R12NZ9015E
IF80 BLUE	IF80+backlight: Blue	R12NZ9015F
IF80 INFRARED	IF80+backlight: Infrared light	R12NZ9015G

### 6.2 Plate (series: IF-80)

#### 6.2.1 Plate (Anti-static)

Product name	Specification	Model number
FLAT PLATE-80	Flat (Ocher) Material: POM-C-ED (Anti-static)	R12NZ9015H
ANTI-ROLL PLATE-80dia.0.7-1.5	Anti-roll (Ocher) Supported work piece: $\varnothing$ 0.7-1.5 Material: POM-C ED (Anti-static)	R12NZ9015J
ANTI-ROLL PLATE-80dia.1.5-3.5	Anti-roll (Ocher) Supported work piece: $\varnothing$ 1.5-3.5 Material: POM-C ED (Anti-static)	R12NZ9015K
ANTI-STICK PLATE-80	Anti-stick (Ocher) Material: POM-C ED (Anti-static)	R12NZ9015L
FLAT PLATE (BLACK)-80	Flat (Black) Material: POM-C EC (Anti-static)	R12NZ9015R
ANTI-ROLL PLATE (BLACK)-80dia.0.7-1.5	Anti-roll (Black) Supported work piece: $\varnothing$ 0.7-1.5 Material: POM-C EC (Anti-static)	R12NZ9015T
ANTI-ROLL PLATE (BLACK)-80dia.1.5-3.5	Anti-roll (Black) Supported work piece: $\varnothing$ 1.5-3.5 Material: POM-C EC (Anti-static)	R12NZ9015U
ANTI-STICK PLATE (BLACK)-80	Anti-stick (Black) Material: POM-C EC (Anti-static)	R12NZ9015V

### 6.2.2 Plate (FDA)

\* We use materials which conformed FDA (Food and Drug Administration).  
(FDA 21CFR177.2470 & 21CFR178.3297)

Product name	Specification	Model number
FLAT PLATE MED-80	Flat (White)/ FDA* Material: POM-C (white) (FDA)	R12NZ90161
ANTI-ROLL PLATE MED-80dia.0.7-1.5	Anti-roll (White)/ FDA* Supported work piece: $\varnothing$ 0.7-1.5 Material: POM-C (white) (FDA)	R12NZ90162
ANTI-ROLL PLATE MED-80dia.1.5-3.5	Anti-roll (White)/ FDA* Supported work piece: $\varnothing$ 1.5-3.5 Material: POM-C (white) (FDA)	R12NZ90163
ANTI-STIC PLATE MED-80	Anti-stick (White)/ FDA* Material: POM-C (white) (FDA)	R12NZ90164
ANTI-ROLL PLATE MED(BK)-80dia.0.7-1.5	Anti-roll (Black)/ FDA* Supported work piece: $\varnothing$ 0.7-1.5 Material: POM-C (black) (FDA)	R12NZ90169
ANTI-ROLL PLATE MED(BK)-80dia.1.5-3.5	Anti-roll (Black)/ FDA* Supported work piece: $\varnothing$ 1.5-3.5 Material: POM-C (black) (FDA)	R12NZ9016A
ANTI-STICK PLATE MED(BK)-80	Anti-stick (Black)/ FDA* Material: POM-C (black) (FDA)	R12NZ9016B

### 6.2.3 Plate for Purging Option (Anti-static)

Product name	Specification	Model number
FLAT PLATE PURGE-80	Flat (Ocher) Material: POM-C ED (Anti-static)	R12NZ9015M
ANTI-ROLL PLATE PURGE-80dia.0.7-1.5	Anti-roll (Ocher) Supported work piece: $\varnothing$ 0.7-1.5 Material: POM-C ED (Anti-static)	R12NZ9015N
ANTI-ROLL PLATE PURGE-80dia.1.5-3.5	Anti-roll (Ocher) Supported work piece: $\varnothing$ 1.5-3.5 Material: POM-C ED (Anti-static)	R12NZ9015P
ANTI-STICK PLATE PURGE-80	Anti-stick (Ocher) Material: POM-C ED (Anti-static)	R12NZ9015Q
FLAT PLATE PURGE(BLACK)-80	Flat (Black) Material: POM-C EC (Anti-static)	R12NZ9015W
ANTI-ROLL PLATE PURGE(BK)-80dia.0.7-1.5	Anti-roll (Black) Supported work piece: $\varnothing$ 0.7-1.5 Material: POM-C EC (Anti-static)	R12NZ9015X
ANTI-ROLL PLATE PURGE(BK)-80dia.1.5-3.5	Anti-roll (Black) Supported work piece: $\varnothing$ 1.5-3.5 Material: POM-C EC (Anti-static)	R12NZ9015Y
ANTI-STIC PLATE PURGE(BK)-80	Anti-stick (Black) Material: POM-C EC (Anti-static)	R12NZ9015Z

## 6. Option Part List

### 6.2.4 Plate for Purging Option (FDA)

\* We use materials which conformed FDA (Food and Drug Administration).  
(FDA 21CFR177.2470 & 21CFR178.3297)

Product name	Specification	Model number
FLAT PLATE PURGE MED-80	Flat (White)/ FDA* Material: POM-C (white) (FDA)	R12NZ90165
ANTI-ROLL PLATE PURGE MED-80dia.0.7-1.5	Anti-roll (White)/ FDA* Supported work piece: $\varnothing$ 0.7-1.5 Material: POM-C (white) (FDA)	R12NZ90166
ANTI-ROLL PLATE PURGE MED-80dia.1.5-3.5	Anti-roll (White)/ FDA* Supported work piece: $\varnothing$ 1.5-3.5 Material: POM-C (white) (FDA)	R12NZ90167
ANTI-STICK PLATE PURGE MED-80	Anti-stick (White)/ FDA* Material: POM-C (white) (FDA)	R12NZ90168
ANTI-ROLL PLATE PURGE MED(BK)-80dia0.7-	Anti-roll (Black)/ FDA* Supported work piece: $\varnothing$ 0.7-1.5 Material: POM-C (black) (FDA)	R12NZ9016C
ANTI-ROLL PLATE PURGE MED(BK)-80dia1.5-	Anti-roll (Black)/ FDA* Supported work piece: $\varnothing$ 1.5-3.5 Material: POM-C (black) (FDA)	R12NZ9016D
ANTI-STICK PLATE PUR MED(BK)-80	Anti-stick (Black)/ FDA* Material: POM-C (black) (FDA)	R12NZ9016E

### 6.3 Hopper (series: IF-80)

Product name	Specification	Model number
160cm <sup>3</sup> HOPPER – 80	160cm <sup>3</sup> Hopper	R12NZ9016F
160cm <sup>3</sup> HOPPER MEDICAL - 80	160cm <sup>3</sup> Hopper /FDA*	R12NZ9016G

\* We use materials which conformed FDA (Food and Drug Administration).  
(FDA 21CFR177.2470 & 21CFR178.3297)

### 6.4 Others, Accessories (series: IF-80)

Product name	Specification	Model number
PLATE FIXATION KIT - 80	Platform kit	R12NZ9016M
PURGE BOX – 80	Purging box	R12NZ9016N
PURGE BOX MED – 80	Purging box /FDA*	R12NZ9016P
HOPPER FIXATION KIT - 80	Hopper fixation kit	R12NZ9016H
HOPPER HEIGHT ADAPTER - 80	Hopper height adjustment adapter	R12NZ9016J
POWER CABLE 80/240	Power cable	R12NZ9016K
RJ45 CAT5e -SF/UTP 5m GREY CABLE	Ethernet cable	R12NZ9016L

\* We use materials which conformed FDA (Food and Drug Administration).  
(FDA 21CFR177.2470 & 21CFR178.3297)

### 6.5 Backlight (series: IF-80)

Product name	Specification	Model number
GREEN BACKLIGHT - 80	backlight: Green	R12NZ9016Q
RED BACKLIGHT - 80	backlight: Red	R12NZ9016R
BLUE BACKLIGHT - 80	backlight: Blue	R12NZ9016T
WHITE BACKLIGHT - 80	backlight: White	R12NZ9016U
INFRARED BACKLIGHT - 80	backlight: Infrared light	R12NZ9016V

### 6.6 License (series: common)

Product name	Specification	Model number
Part Feeding License	Part Feeding License	R12NZ90106
Part Feeding License for USB Key	Part Feeding License for USB Key	R12NZ90107

## 7. Troubleshooting

For trouble, refer to following manual.

*EPSON RC+ 7.0 Option Part Feeding 7.0 Introduction & Software*  
*" Trouble Shooting"*