

EPSON

ROBOT CONTROLLER

RC700-D

Manual

Rev.7

ENM247C6587F

Original instructions

Control Unit RC700-D

ROBOT CONTROLLER

RC700-D Manual Rev.7

ROBOT CONTROLLER

RC700-D Manual

Rev.7

FOREWORD

Thank you for purchasing our robot products.

This manual contains the information necessary for the correct use of the robot controller. Please carefully read this manual and other related manuals before installing the robot system.

Keep this manual handy for easy access at all times.

The robot system and its optional parts are shipped to our customers only after being subjected to the strictest quality controls, tests, and inspections to certify its compliance with our high performance standards. Please note that the basic performance of the product will not be exhibited if our robot system is used outside of the usage conditions and product specifications described in the manuals.

This manual describes possible dangers and consequences that we can foresee. Be sure to comply with safety precautions on this manual to use our robot system safely and correctly.

TRADEMARKS

Microsoft, Windows, and Windows logo are either registered trademarks or trademarks of Microsoft Corporation in the United States and/or other countries. Other brand and product names are trademarks or registered trademarks of the respective holders.

TRADEMARK NOTATION IN THIS MANUAL

Microsoft® Windows® 8 operating system

Microsoft® Windows® 10 operating system

Microsoft® Windows® 11 operating system

Throughout this manual, Windows 8, Windows 10 and Windows 11 refer to above respective operating systems. In some cases, Windows refers generically to Windows 8, Windows 10 and Windows 11.

NOTICE

No part of this manual may be copied or reproduced without authorization.

The contents of this manual are subject to change without notice.

Please notify us if you should find any errors in this manual or if you have any comments regarding its contents.

MANUFACTURER

SEIKO EPSON CORPORATION

CONTACT INFORMATION

Contact information is described in “SUPPLIERS” in the first pages of the following manual:

Robot System Safety Manual Read this manual first

DISPOSAL

When disposing this product, dispose in accordance with the laws and regulations of each country.

Regarding battery disposal

The battery removal/replacement procedure is described in the following manuals:
Maintenance Manual

For European Union customers only



The crossed out wheeled bin label that can be found on your product indicates that this product and incorporated batteries should not be disposed of via the normal household waste stream. To prevent possible harm to the environment or human health please separate this product and its batteries from other waste streams to ensure that it can be recycled in an environmentally sound manner. For more details on available collection facilities please contact your local government office or the retailer where you purchased this product. Use of the chemical symbols Pb, Cd or Hg indicates if these metals are used in the battery.



This information only applies to customers in the European Union, according to Directive 2006/66/EC OF THE EUROPEAN PARLIAMENT AND OF THE COUNCIL OF 6 September 2006 on batteries and accumulators and waste batteries and accumulators and repealing Directive 91/157/EEC and legislation transposing and implementing it into the various national legal systems, and to customers in countries in Europe, Middle East and Africa (EMEA) where they have implemented equivalent regulations.

For other countries, please contact your local government to investigate the possibility of recycling your product.

For Users in Taiwan region



Please separate used batteries from other waste streams to ensure that it can be recycled in an environmentally sound manner. For more details on available collection facilities please contact your local government office or the retailer where you purchased this product.

For California customers only

The lithium batteries in this product contain
Perchlorate Material - special handling may apply,
See www.dtsc.ca.gov/hazardouswaste/perchlorate

Before Reading This Manual

 CAUTION	<ul style="list-style-type: none">■ Necessity of organizational measures for cyber security The following organizational measures should be taken to address cyber security risks:<ul style="list-style-type: none">- Perform risk analysis based on security threats and vulnerabilities related to your organization's assets.- Develop a security policy to address risks and educate and train appropriate personnel.- Create guidelines for how to respond when security issues arise and make them known throughout your organization. ■ Security measures for network connections Epson robot systems are designed to be used within a closed local area network. Please refrain from connecting to networks with Internet access. If a connection to the Internet is required, please implement the necessary technical measures* to protect from malicious attacks and vulnerabilities over the Internet. *: These measures include, but are not limited to, access controls, firewalls, data diodes, and so on.
--	--

NOTE



Do not connect the followings to the TP port of RC700-D. Connecting to the followings may result in malfunction of the device since the pin assignments are different.

OPTIONAL DEVICE dummy plug

Operation Pendant OP500

Operator Pendant OP500RC

Jog Pad JP500

Teaching Pendant TP-3**

Operator Panel OP1

NOTE



For RC700-D, be sure to install the Epson RC+ to the development PC first, then connect the development PC and RC700-D with the USB cable.

If RC700-D and the development PC are connected without installing the Epson RC+ to the development PC, [Add New Hardware Wizard] appears. If this wizard appears, click the <Cancel> button.

NOTE



Concerning the security support for the network connection:

The network connecting function (Ethernet) on our products assumes the use in the local network such as the factory LAN network. Do not connect to the external network such as Internet.

In addition, please take security measure such as for the virus from the network connection by installing the antivirus software.

NOTE



Security support for the USB memory:

Make sure the USB memory is not infected with virus when connecting to the Controller.

Structure of Robot System

Controller RC700-D can be used with the following version.

EPSON RC+ 7.0 Ver.7.5.1B or later

Epson RC+ 8.0

Each Manipulator can be used with the following version.

GX4, GX8 series: EPSON RC+ 7.0 Ver.7.5.1B, Epson RC+ 8.0

Setting by Using Software

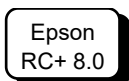
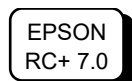

This manual contains setup procedures using the software.

Those sections are indicated by the symbol on the left.

The Manuals of This Product

The following are typical manual types for this product and an outline of the descriptions.

Safety Manual (book, PDF)

This manual contains safety information for all people who handle this product. The manual also describes the process from unpacking to operation and the manual you should look at next.

Read this manual first.

- Safety precautions regarding robot system and residual risk
- Declaration of conformity
- Training
- Flow from unpacking to operation

RC700-D series Manual (PDF)

This manual explains the installation of the entire robot system and the specifications and functions of the controller. The manual is primarily intended for people who design robot systems.

- The installation procedure of the robot system (specific details from unpacking to operation)
- Daily inspection of the controller
- Controller specifications and basic functions

GX series Manual (PDF)

This manual describes the specifications and functions of the Manipulator. The manual is primarily intended for people who design robot systems.

- Technical information, functions, specifications, etc. required for the Manipulator installation and design
- Daily inspection of the Manipulator

Status Code/Error Code List (PDF)

This manual contains a list of code numbers displayed on the controller and messages displayed in the software message area. The manual is primarily intended for people who design robot systems or do programming.

Epson RC+ User's Guide (PDF)

This manual describes general information about program development software.

Epson RC+ SPEL+ Language Reference (PDF)

This manual describes the robot programming language "SPEL+".

Other Manual (PDF)

Manuals for each option are available.

Manuals About Maintenance, Service

Manuals about Maintenance or Service does not come with the products.

Only authorized personnel who have taken maintenance training held by the manufacturer or dealer should be allowed to perform the robot maintenance. Please contact the supplier of your region for more information.

Installation

1. Safety	3
1.1 Conventions.....	3
2. Installation	4
2.1 System Example.....	4
2.2 Unpacking.....	5
2.3 Transportation.....	5
2.3.1 Transportation Precautions	5
2.3.2 Number of people and position to hold, when transporting manipulator	5
2.4 Manipulator Installation	7
2.4.1 Transportation Precautions	7
2.4.2 Environment	7
2.4.3 Noise level.....	8
2.4.4 Base Table	8
2.4.5 Installation Procedure.....	10
2.5 Control Unit Installation.....	15
2.5.1 Environment	15
2.5.2 Installation	16
2.5.3 Wall Mounting Option	18
2.6 Designing a Safe Robot System	19
2.6.1 Environmental Conditions.....	19
2.6.2 System Layout.....	19
2.6.3 Disabling Power to the System using lock out / tag out.....	20
2.6.4 End Effector Design.....	21
2.6.5 Peripheral Equipment Design.....	21
2.6.6 Remote Control	21
2.6.7 Emergency Stop.....	22
2.6.8 Safeguard.....	24
2.6.9 Presence Sensing Device	25
2.6.10 Resetting the Safeguard.....	26
2.6.11 Robot Operation Panel.....	26
2.7 Connecting.....	26
2.7.1 Connection to EMERGENCY Connector.....	26
2.7.2 Power Supply	33
2.7.3 Connecting Manipulator and Controller	35
2.8 Saving Default Status	35

3. Power-ON	36
3.1 Power-ON Precautions.....	36
3.2 Power ON Procedure	37
4. First Step	38
4.1 Installing Epson RC+ Software.....	38
4.2 Development PC and Controller Connection.....	38
4.2.1 About Development PC Connection USB Port	39
4.2.2 Precaution.....	39
4.2.3 Software Setup and Connection Check	40
4.2.4 Backup the initial condition of the Controller	41
4.2.5 Disconnection of Development PC and Controller	42
4.2.6 Moving the Robot to Initial Position.....	42
4.3 Writing your first program	47
4.4 Firmware Update.....	53
4.4.1 Updating Firmware.....	53
4.4.2 Firmware Upgrade Procedure.....	53
4.4.3 Controller Recovery	56
4.4.4 Firmware Initialization Procedure.....	57
4.4.5 Adding Confirmation Steps by Strengthening Security of EtherNet Connection	59
5. Second Step	63
5.1 Connection with External Equipment.....	63
5.1.1 Remote Control.....	63
5.1.2 Ethernet	63
5.1.3 RS-232C (Option)	63
5.1.4 Analog I/O board (Option).....	63
5.1.5 Force Sensor I/F board (Option)	63
5.2 Ethernet Connection of Development PC and Controller	64
5.3 Connection of Teach Pendant (Option)	64

Functions

1. Specifications	67
1.1 System Example	67
1.2 Standard Specifications	68
1.3 Outer Dimensions	70
2. Part Names and Functions	71
2.1 LED and Seven-segment LED	75
2.1.1 LED and Seven-segment LED Display	75
2.1.2 Particular Status Display	77
2.2 Safety Function	77
2.3 Protection Features	78
3. Installation	80
3.1 Unpacking	80
3.2 Environmental Requirements	80
3.2.1 Environment	80
3.2.2 Installation	81
3.2.3 Wall Mounting Option	83
3.3 Power Supply	84
3.3.1 Specifications	84
3.3.2 AC Power Cable	85
3.4 Cable Connection	86
3.4.1 Typical Cable Connection	87
3.4.2 Connecting Manipulator to Controller	89
3.5 Noise Countermeasures	90
4. Operation Mode (TEACH/AUTO/TEST)	92
4.1 Overview	92
4.2 Switch Operation Mode	93
4.3 Program Mode (AUTO)	94
4.3.1 What is Program Mode (AUTO)?	94
4.3.2 Setup from Epson RC+	94
4.4 Auto Mode (AUTO)	95
4.4.1 What is Auto mode (AUTO)?	95
4.4.2 Setup from EPSON RC+	95
4.4.3 Setup from Control Device	96

5. Development PC Connection USB Port	97
5.1 About Development PC Connection USB Port.....	97
5.2 Precaution	97
5.3 PC and Controller Connection Using Development PC Connection USB Port	98
5.4 Disconnection of Development PC and Controller	99
5.5 How to Fix USB Cable.....	100
6. Memory Port	101
6.1 What is Backup Controller Function?	101
6.2 Before Using Backup Controller Function.....	101
6.2.1 Precautions	101
6.2.2 Adoptable USB Memory	101
6.3 Backup Controller Function	102
6.3.1 Backup Controller with Trigger Button	102
6.3.2 Load Data with Epson RC+.....	102
6.3.3 Transfer with E-mail	102
6.4 Details of Data.....	103
7. LAN (Ethernet Communication) Port	104
7.1 About the LAN (Ethernet Communication) Port.....	104
7.2 IP Address.....	104
7.3 Changing Controller IP Address	105
7.4 Connection of Development PC and Controller with Ethernet.....	107
7.5 Disconnection of Development PC and Controller with Ethernet.....	110
8. TP Port	111
8.1 What is the TP Port?	111
8.2 Teach Pendant Connection	112
9. EMERGENCY	113
9.1 Safety Door Switch and Latch Release Switch.....	114
9.1.1 Safety Door Switch	114
9.1.2 Latch Release Switch	115
9.1.3 Checking Latch Release Switch Operation.....	115
9.2 Emergency Stop Switch Connection	116
9.2.1 Emergency Stop Switch.....	116
9.2.2 Checking Emergency Stop Switch Operation	116

9.2.3	Recovery from Emergency Stop.....	116
9.3	Pin Assignments	117
9.4	Circuit Diagrams	118
9.4.1	Example 1: External emergency stop switch typical application.....	118
9.4.2	Example 2: External safety relay typical application.....	119
10. Standard RS-232C Port		120
10.1	RS-232C Port.....	120
10.2	Confirmation with Epson RC+ (RS-232C).....	121
10.3	RS-232C Software Communication Setup (RS-232C).....	122
10.4	Communication Cable (RS-232C).....	122
11. I/O Connector		123
11.1	Input Circuit.....	123
11.1.1	Typical Input Circuit Application 1.....	124
11.1.2	Typical Input Circuit Application 2.....	125
11.2	Output Circuit.....	126
11.2.1	Typical Output Circuit Application 1: Sink Type (NPN).....	127
11.2.2	Typical Output Circuit Application 2: Source Type (PNP).....	127
11.3	Pin Assignments	128
12. I/O Remote Settings		129
12.1	I/O Signal Description	130
12.1.1	Remote Input Signals	130
12.1.2	Remote Output Signals	134
12.2	Timing Specifications	138
12.2.1	Design Notes for Remote Input Signals.....	138
12.2.2	Timing Diagram for Operation Execution Sequence.....	138
12.2.3	Timing Diagram for Program Execution Sequence	138
12.2.4	Timing Diagram for Safety Door Input Sequence	139
12.2.5	Timing Diagram for Emergency Stop Sequence	139
13. R-I/O Connector		140
13.1	Input Circuit.....	140
	Typical Input Circuit Application 1	140
	Typical Input Circuit Application 2	140
13.2	Pin Assignments	141

14. Option Slots	142
14.1 About Option Slots	142
14.2 Expansion I/O Board	142
14.2.1 Expansion I/O Board	142
14.2.2 Board Configuration (Expansion I/O Board).....	142
14.2.3 Confirmation with Epson RC+ (Expansion I/O Board).....	143
14.2.4 Input Circuit.....	144
14.2.5 Output Circuit.....	146
14.2.6 Pin Assignments (Expansion I/O Board).....	148
14.3 Fieldbus I/O Board	152
14.4 RS-232C Board	153
14.4.1 About the RS-232C Board	153
14.4.2 Board Setup (RS-232C).....	153
14.4.3 Confirmation with Epson RC+ (RS-232C).....	154
14.4.4 RS-232C Software Communication Setup (RS-232C).....	155
14.4.5 Communication Cable (RS-232C).....	155
14.5 PG Board.....	156
14.6 Analog I/O Board.....	156
14.6.1 About Analog I/O Board	156
14.6.2 Board Configuration (Analog I/O Board)	157
14.6.3 Confirmation with Epson RC+ (Analog I/O Board)	160
14.6.4 Input Circuit (Analog I/O Board)	162
14.6.5 Output Circuit (Analog I/O Board)	162
14.6.6 Pin Assignments (Analog I/O Board)	163
14.7 Force Sensor I/F Board	164
14.7.1 About Force Sensor I/F Board	164
14.7.2 Board Configuration (Force Sensor I/F Board).....	164
14.7.3 Confirmation with Epson RC+ (Force Sensor I/F Board)	165
14.8 EUROMAP67 Board.....	166
14.8.1 Notes on the EUROMAP67 Board	168
14.8.2 Board Settings (EUROMAP67 Board)	169
14.8.3 Installation (EUROMAP67 Board).....	169
14.8.4 Confirming with Epson RC+ (EUROMAP67 Board).....	170
14.8.5 Sample Project (EUROMAP67 Board).....	171
14.8.6 Circuit Overview (EUROMAP67 Board).....	172
14.8.7 Input Circuit (EUROMAP67 Board).....	173
14.8.8 Output Circuit (EUROMAP67 Board).....	173
14.8.9 Emergency Stop, Safeguard (EUROMAP67 Board)	174
14.8.10 I/O Pin Assignments (EUROMAP67 Board).....	175

14.8.11 Emergency stop connector Pin Assignments (EUROMAP67 Board).....	177
--	-----

Regular Inspection

1. Regular Inspection for RC700-D	181
1.1 Inspections and Schedules	181
2. Backup and Restore	182
2.1 What is the Backup Controller Function?.....	182
2.2 Backup Data Types.....	182
2.3 Backup.....	183
2.4 Restore	184
3. Alarm	187
3.1 Maintenance	187
3.2 How to View the Maintenance Information.....	188
3.3 How to Edit the Maintenance Information	191
3.4 Alarm Notifying Method.....	193
3.5 How to Cancel the Alarm	194

Appendix

Appendix A: Option Parts List	197
--------------------------------------	------------

Installation

This section describes outline from unpacking to operation of Robot System and design of Robot System.

1. Safety



Please read “Safety Manual” and check safety considerations before installing the robot system or before connecting cables.

Keep this manual handy for easy access at all times.

This product is intended for transporting and assembling parts in a safely isolated area and dedicated to Epson robots used in industrial environments.

1.1 Conventions

Important safety considerations are indicated throughout the manual by the following symbols. Be sure to read the descriptions shown with each symbol.

 WARNING	This symbol indicates that a danger of possible serious injury or death exists if the associated instructions are not followed properly.
 WARNING	This symbol indicates that a danger of possible harm to people caused by electric shock exists if the associated instructions are not followed properly.
 CAUTION	This symbol indicates that a danger of possible harm to people or physical damage to equipment and facilities exists if the associated instructions are not followed properly.

2. Installation

2.1 System Example

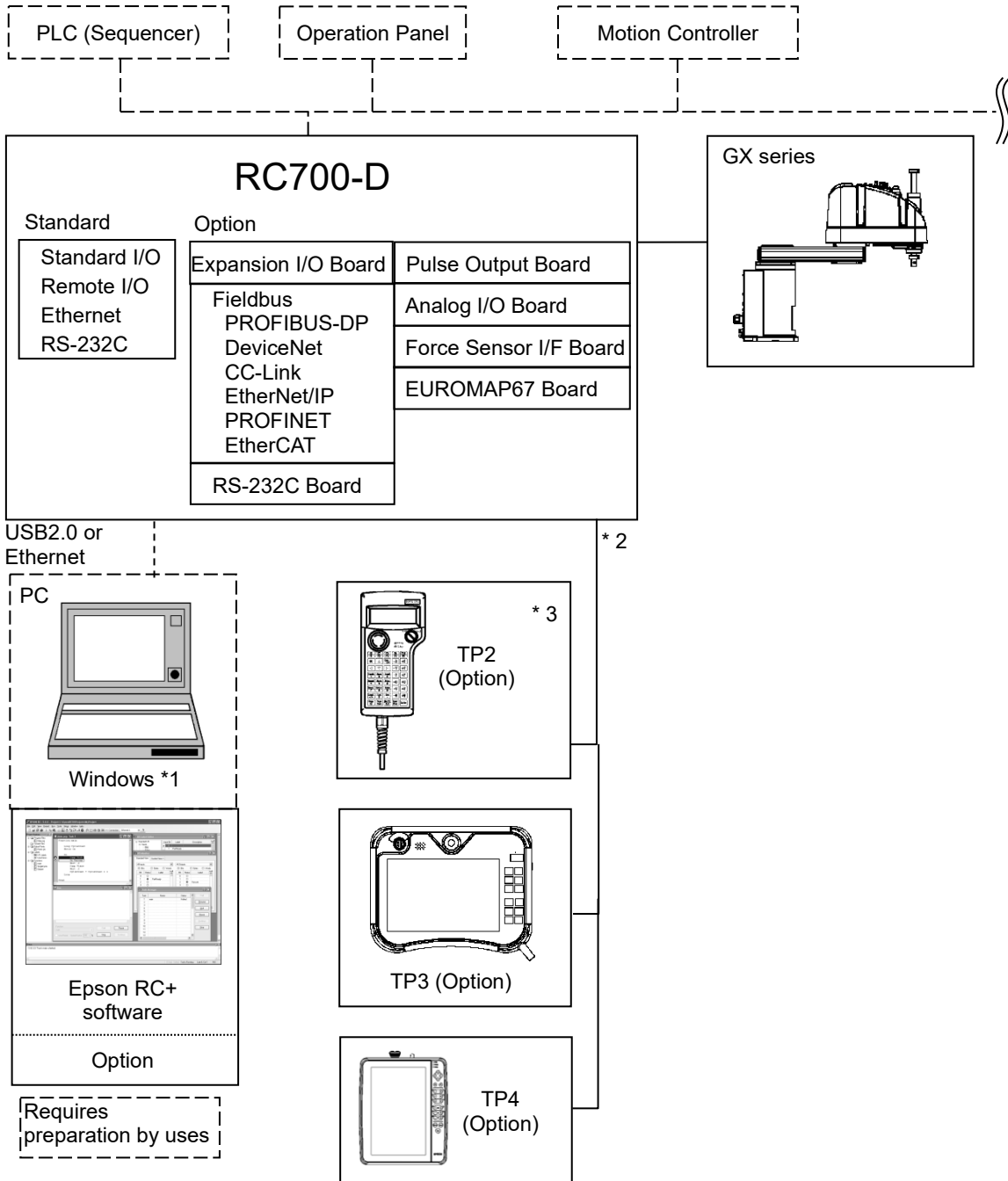

*1 For system requirements, refer to the following manual:
Epson RC+ User's Guide

*2 Any one of the Teach pendant can be controlled.

*3 When connecting to RC700-D, a dedicated conversion cable is required.

2.2 Unpacking

Unpacking of the Manipulators and robotic equipment shall be performed by personnel who has taken robot system training held by us and suppliers and should conform to all national and local codes.

Please read “Safety Manual” and check safety considerations before installing the robot system or before connecting cables.

2.3 Transportation

2.3.1 Transportation Precautions

Transporting of the Manipulators and robotic equipment shall be performed by personnel who has taken robot system training held by us and suppliers and should conform to all national and local codes.

Please read “Safety Manual” and check safety considerations before installing the robot system or before connecting cables.

During unpacking and relocation, avoid applying external force to the arms and motors of the Manipulator.

When transporting the Manipulator for a long distance, secure it to the delivery equipment so that the Manipulator cannot fall. If necessary, pack the Manipulator in the same way as it was delivered.

2.3.2 Number of people and position to hold, when transporting manipulator

GX4

Where to hold : Under the arm 1 and bottom of the base *(shade part)
 * When hold bottom of the base, be careful not caught your hands or fingers.

Minimum number of people : 2 people

Do not hold : -

Table Top Mounting

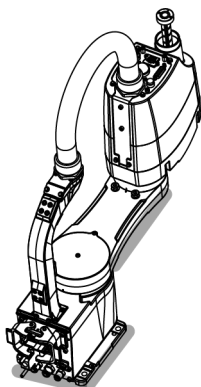

Multiple Mounting

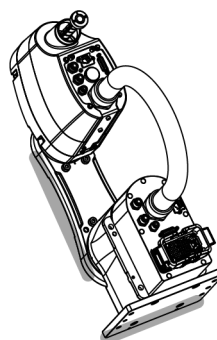

GX8

How to transfer : Pass belts through the eyebolts and hoist it with your hands.

Where to hold : Under the arm 1 and bottom of the base *(shade part)
* When hold bottom of the base, be careful not caught your hands or fingers.

Minimum number of people : 2 people

Do not hold :-

Table Top Mounting

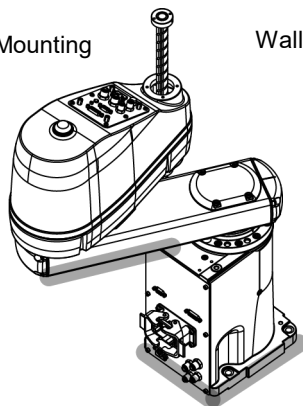

Wall Mounting

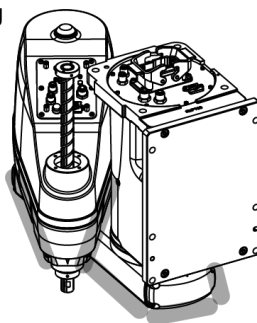

Ceiling Mounting

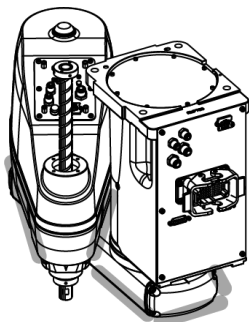

2.4 Manipulator Installation

2.4.1 Transportation Precautions

Installing of the Manipulators and robotic equipment shall be performed by personnel who has taken robot system training held by us and suppliers and should conform to all national and local codes.

Please read “Safety Manual” and check safety considerations before installing the robot system or before connecting cables.

2.4.2 Environment

A suitable environment is necessary for the robot system to function properly and safely. Be sure to install the robot system in an environment that meets the following conditions:

Item	Environment
Ambient temperature *	5 ~ 40 °C
Ambient relative humidity (no condensation)	20 ~ 80 %
Fast transient burst noise	1 kV or less(signal wire)
Electrostatic noise	4 kV or less
Altitude	2000 m or less
Environment	<ul style="list-style-type: none"> - Install indoors. - Keep away from direct sunlight. - Keep away from dust, oily smoke, salinity, metal powder or other contaminants. - Keep away from flammable or corrosive solvents and gases. - Keep away from water. - Keep away from shocks or vibrations. - Keep away from sources of electric noise. - Keep away from explosive area - Keep away from a large quantity of radiation

* When the product is used in a low temperature environment around the minimum temperature of the product specification, or when the product is suspended for a long time on holidays or at night, a collision detection error may occur due to the large resistance of the drive unit immediately after the start of operation. In such a case, it is recommended to warm up for about 10 minutes.





- Manipulators are not suitable for operation in harsh environments such as painting areas, etc. When using Manipulators in inadequate environments that do not meet the above conditions, please contact the supplier of your region.
- If there are conductive things such as fences or ladders within 2.5 m of the Manipulator, ground the things.

Special Environmental Conditions

The surface of the Manipulator has general oil resistance. However, if your requirements specify that the Manipulator must withstand certain kinds of oil, please contact the supplier of your region.

Rapid change in temperature and humidity can cause condensation inside the Manipulator. If your requirements specify that the Manipulator handles food, please contact the supplier of your region to check whether the Manipulator will damage the food or not.

The Manipulator cannot be used in corrosive environments where acid or alkaline is used. In a salty environment where the rust is likely to gather, the Manipulator is susceptible to rust.

 WARNING	<ul style="list-style-type: none"> ■ Use an earth leakage breaker on the AC power cable of the Controller to avoid the electric shock and circuit breakdown. Prepare the earth leakage breaker that pertains the Controller you are using. For details, refer to the Robot Controller manual.
 CAUTION	<ul style="list-style-type: none"> ■ When cleaning the Manipulator, do not rub it strongly with alcohol or benzene. It may lose luster on the coated face.

2.4.3 Noise level

About noise level due to manipulator operation, refer to the following manual.

Manipulator manual Appendix A. Specifications Table

2.4.4 Base Table

A base table for anchoring the Manipulator is not supplied. Please make or obtain the base table for your Manipulator. The shape and size of the base table differs depending on the use of the robot system. For your reference, we list some Manipulator table requirements here.

The base table must not only be able to bear the weight of the Manipulator but also be able to withstand the dynamic movement of the Manipulator when it operates at maximum acceleration. Ensure that there is enough strength on the base table by attaching reinforcing materials such as crossbeams.

The torque and reaction force produced by Manipulator motion are as follows:

	GX4	GX8
Max. Reaction torque on the horizontal plate (N·m)	500	700
Max. Horizontal reaction force (N)	2,000	4,000
Max. Vertical reaction force (N)	1,000	1,500
Threaded holes for Mounting screw	M8	M8 or M10*

*: M8 or M10 for Table Top Mounting and Ceiling Mounting. M8 for Wall Mounting.

Use the mounting bolts conforming to the strength of ISO898-1 property class 10.9 or 12.9. The plate for the Manipulator mounting face should be 20 mm thick or more and made of steel to reduce vibration. The surface roughness of the steel plate should be 25 μm or less.

The table must be secured on the floor or wall to prevent it from moving.
 The Manipulator installation surface should have a flatness of 0.5 mm or less and an inclination of 0.5 ° or less. If the flatness of the installation surface is improper, the base may be damaged or the robot may not fully show its performance.
 When using a leveler to adjust the height of the base table, use a screw with M16 diameter.

Connector

If you are passing cables through the holes on the base table, see the figures below.

[unit : mm]

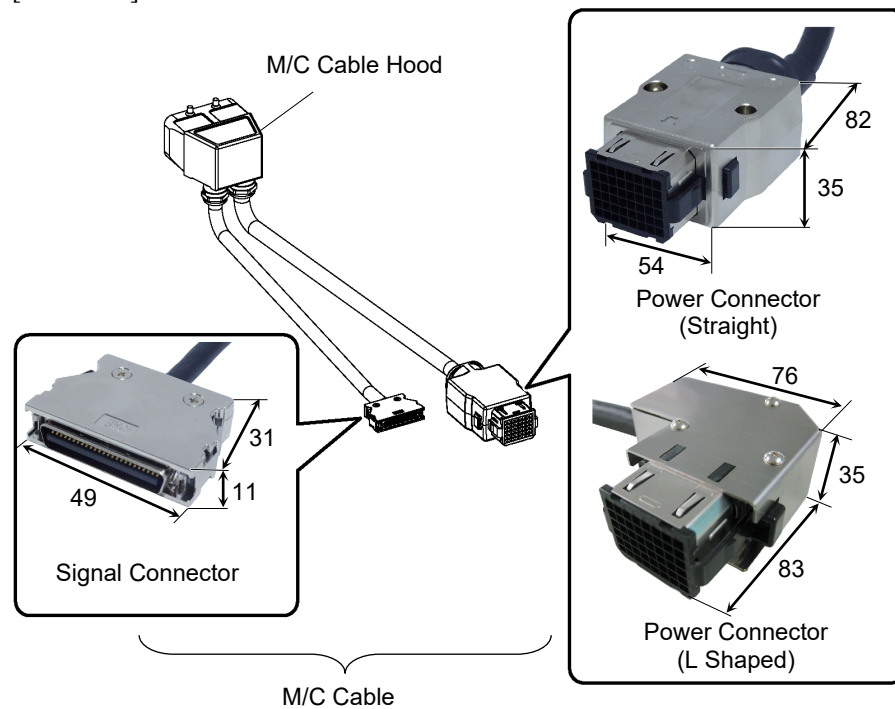

When using the Manipulator in the cleanroom, follow the steps below before the installation.

- (1) Unpack the Manipulator outside of the cleanroom.
- (2) Secure the Manipulator to delivery equipment such as a pallet with bolts so that the Manipulator does not fall over.
- (3) Wipe off the dust on the Manipulator with a little alcohol or distilled water on a lint-free cloth.
- (4) Transport the Manipulator into the cleanroom.
- (5) Secure the Manipulator to the base table.

2.4.5 Installation Procedure



When the Manipulator is cleanroom model, unpack it outside of the cleanroom. Secure the Manipulator not to fall, and then wipe off the dust on the Manipulator with a little alcohol or distilled water on a lint-free cloth. After that, transport the Manipulator into the cleanroom. Connect an exhaust tube to the exhaust port after installation.

GX4 : Table Top Mounting

 CAUTION	<p>■ Install the Table Top Mounting Manipulator with two or more people. The Manipulator weights are as follows. Be careful not to get hands, fingers, or feet caught and/or have equipment damaged by a fall of the Manipulator.</p> <p>GX4-A251**: approx.15 kg : 33 lbs. GX4-A301**: approx.15 kg : 33 lbs. GX4-A351**: approx.16 kg : 35 lbs.</p>
--------------------	---

Standard Specification

- (1) With the arm extended, take the Manipulator from the packing box.



Be careful not to fall the Manipulator as the Manipulator is not secured when you take it from the packing box.

The joints can be rotated by the Manipulator own weight. Be careful not to get hands or fingers caught.

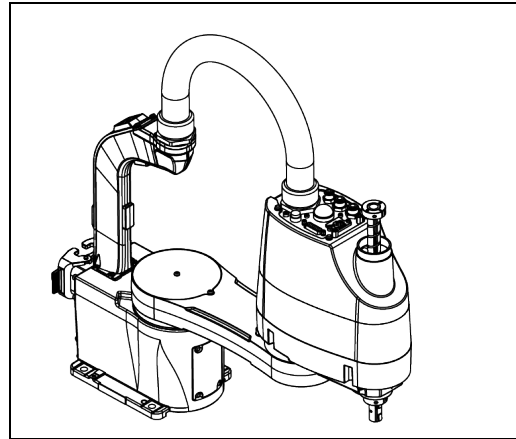

- (2) Secure the base to the base table with four bolts. Be sure to use washers.



Use bolts with specifications conforming to ISO898-1 property class: 10.9 or 12.9.

Tightening torque:
 32.0 N·m (326 kgf·cm)

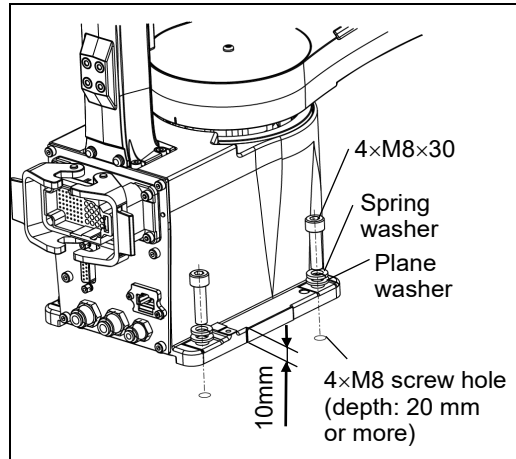

For cable downward:
 Be sure to allow spaces for the center of the table to mount the base.
 Length: 190mm or more
 Width: 104mm
 Depth: 190mm or more

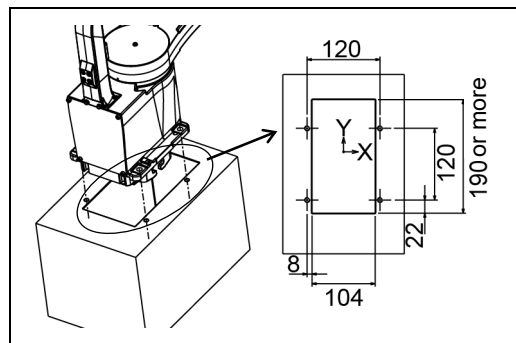

GX4 : Multiple Mounting

 WARNING	<ul style="list-style-type: none"> ■ Install the Multiple Mounting Manipulator with two or more people. The Manipulator weights are as follows. Be careful not to get hands, fingers, or feet caught and/or have equipment damaged by a fall of the Manipulator. GX4-A301*M : approx. 17 kg : 38 lbs. GX4-A351*M : approx. 17 kg : 38 lbs. ■ When installing the Manipulator to the wall, support the Manipulator, and then secure the anchor bolts. Removing the support without securing the anchor bolts properly is extremely hazardous and may result in fall of the Manipulator.
---	--

NOTE
 Make sure that the base table on which the multiple mounting is installed does not interfere with the cables and conduit tubes that connect to the manipulator.

The recommended installation patterns are as follows:

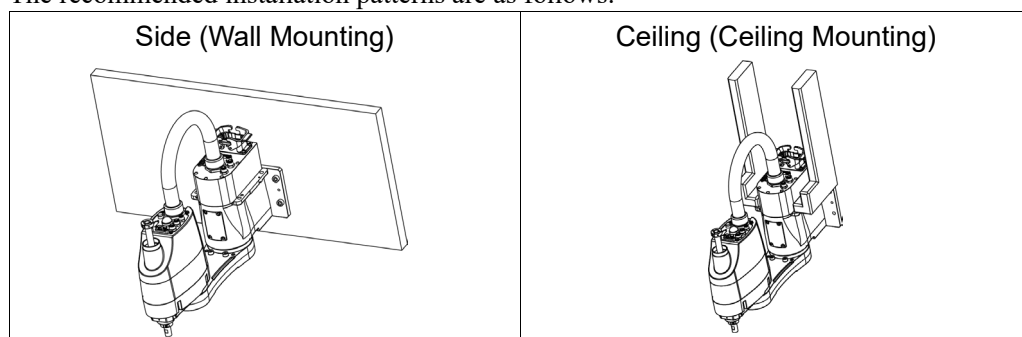

The recommended installation patterns for wall mounting are as follows:

Standard Specification

- (1) Unpack the Manipulator from the box with the Manipulator extends its arms.

NOTE
 Be careful not to fall the Manipulator when unpacking it from the box because the Manipulator is not secured.

Also, the joint may rotate due to the own weight. Be careful not have your hands or fingers caught.

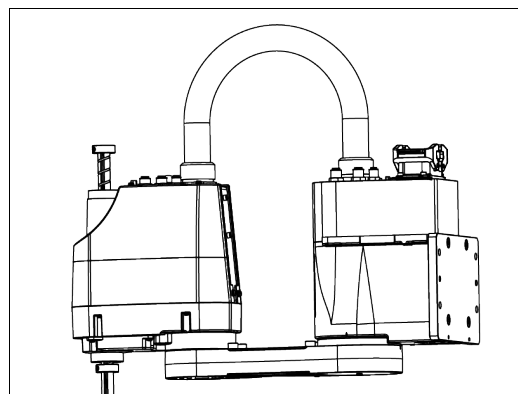

- (2) Secure the base to the wall with four bolts. Make sure to use the washer.

NOTE
 Use bolts with specifications conforming to ISO898-1 Property Class: 10.9 or 12.9.

Tightening torque: 32.0 N·m (326 kgf·cm)

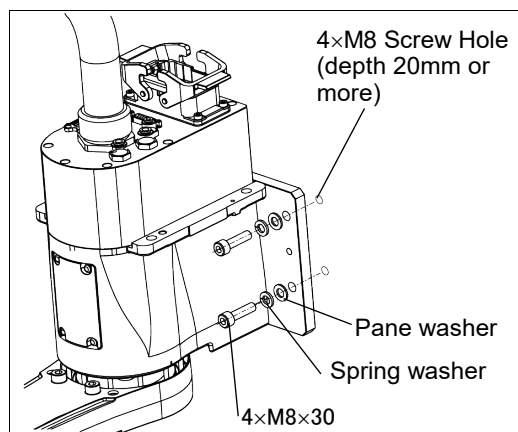

GX8 : Table Top Mounting

 CAUTION	<ul style="list-style-type: none"> ■ Install the Table Top Mounting Manipulator with two or more people. The Manipulator weights are as follows. Be careful not to get hands, fingers, or feet caught and/or have equipment damaged by a fall of the Manipulator. GX8-A45***: approx. 33 kg : 73 lb. GX8-A55***: approx. 34 kg : 75 lb. GX8-A65***: approx. 35 kg : 77 lb.
---	--

Standard Specification

- (1) Secure the base to the base table with four bolts. Be sure to use washers.

NOTE Use bolts with specifications conforming to ISO898-1 Property Class: 10.9 or 12.9.

Tightening torque:

- M8: 32.0 N·m (326 kgf·cm)
- M10: 58.0 N·m (626 kgf·cm)

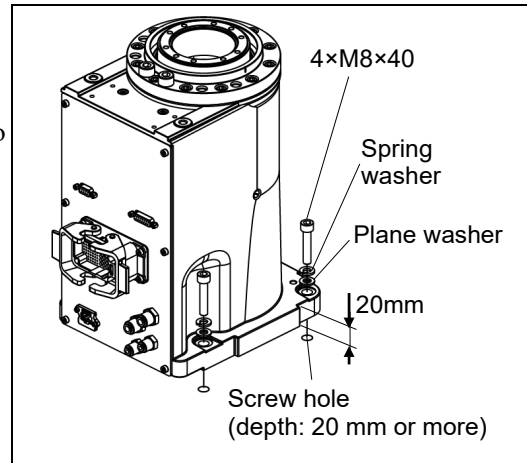

- (2) Using nippers, cut off the wire tie binding the shaft and arm retaining bracket on the base.
- (3) Remove the bolts securing the wire ties removed in step (2).
- (4) Remove the fixing jig for transport.

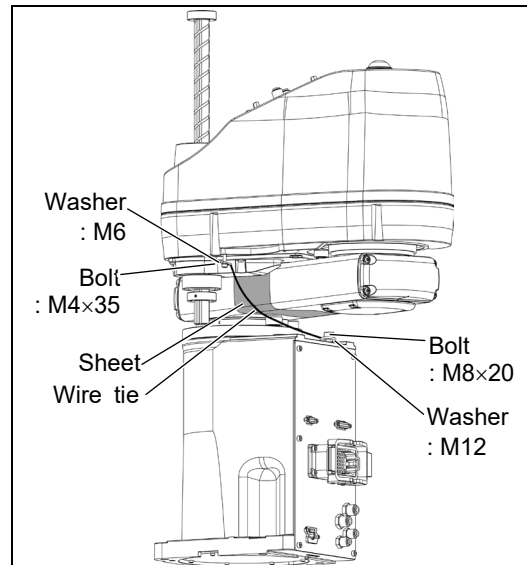

NOTE For cable downward:

- Be sure to allow spaces for the center of the table to mount the base.
- Diameter: ϕ 150mm or more
 - Depth: M/C cable (L-shaped) 120mm or more
 - M/C cable (straight) 190mm more

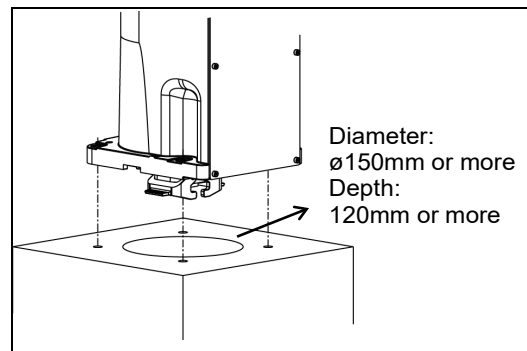

GX8 : Wall Mounting

 WARNING	<ul style="list-style-type: none"> ■ Install the Wall Mounting Manipulator with two or more people. The Manipulator weights are as follows. Be careful not to get hands, fingers, or feet caught and/or have equipment damaged by a fall of the Manipulator. GX8-A45**W : approx. 35 kg : 77 lb. GX8-A55**W : approx. 36 kg : 79 lb. GX8-A65**W : approx. 37 kg : 82 lb. ■ When installing the Manipulator to the wall, support the Manipulator, and then secure the anchor bolts. Removing the support without securing the anchor bolts properly is extremely hazardous and may result in fall of the Manipulator.
---	---

Standard Specification

- (1) With the arm extended, take the Manipulator from the packing box.

The joints can be rotated by the Manipulator own weight. Be careful not to get hands or fingers caught.

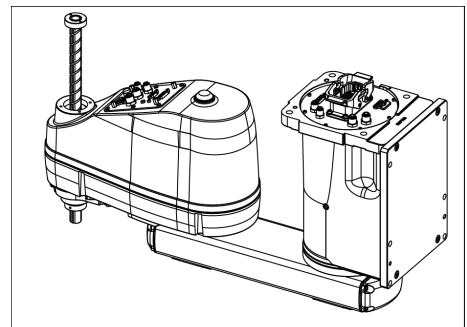

- (2) Secure the base to the wall with four bolts. Make sure to use the washer.

NOTE  Use bolts with specifications conforming to ISO898-1 Property Class: 10.9 or 12.9.

Tightening torque: 32.0 N·m (326 kgf·cm)

- (3) Remove the shipping bolt and jigs.

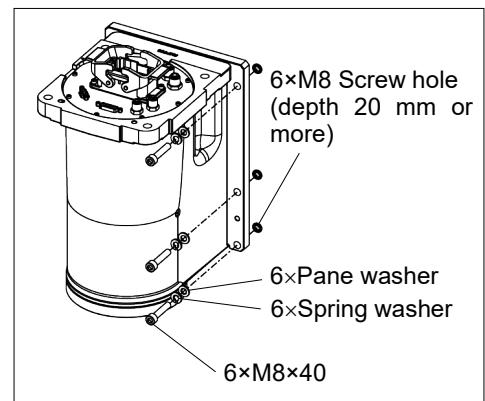

GX8 : Ceilling Mounting

 WARNING	<ul style="list-style-type: none"> ■ Install the Ceiling Mounting Manipulator with two or more people. The Manipulator weights are as follows. Be careful not to get hands, fingers, or feet caught and/or have equipment damaged by a fall of the Manipulator. GX8-A45**R : approx. 33 kg : 73 lb. GX8-A55**R : approx. 34 kg : 75 lb. GX8-A65**R : approx. 35 kg : 77 lb. ■ When installing the Manipulator to the ceiling, support the Manipulator, and then secure the anchor bolts. Removing the support without securing the anchor bolts properly is extremely hazardous and may result in fall of the Manipulator.
---	--

Standard Specification

- (1) With the arm extended, take the Manipulator from the packing box.

The joints can be rotated by the Manipulator own weight. Be careful not to get hands or fingers caught.

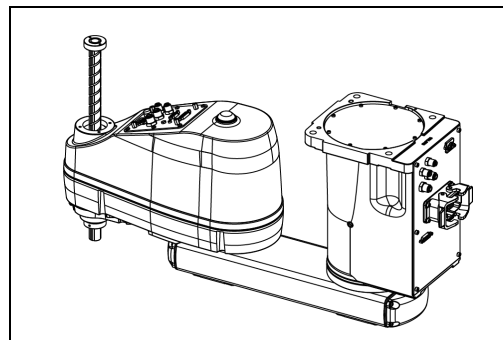

- (2) Secure the base to the ceiling with four bolts. Make sure to use the washer.
- NOTE**  Use bolts with specifications conforming to ISO898-1 Property Class: 10.9 or 12.9.

Tightening torque:

M8 : 32.0 N·m (326 kgf·cm)

M10 : 58.0 N·m (592 kgf·cm)

- (3) Remove the shipping bolt and jigs.

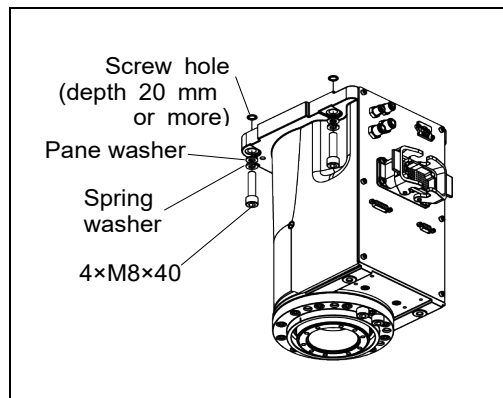

2.5 Control Unit Installation

2.5.1 Environment

For using the robot system function properly and safely, a suitable environment is required. Install the control unit in a location meets the following conditions.

 CAUTION	<ul style="list-style-type: none"> ■ Install the controller at a height of 0.4 to 2m above the floor to maintain easily. ■ Install a power-off switch at a height of 0.6 to 1.9m.
---	---

- NOTE**  - The Controller unit is not designed for cleanroom specification. If it must be installed in a cleanroom, be sure to install it in a proper enclosure with adequate ventilation and cooling.
- Install Controller unit in a location that allows easy connection / disconnection of cables.
 - Install Controller unit outside of the safety door.
 - If there are conductive things such as fences or ladders within 2.5 m of the Controller, ground the things.

Item	Condition
Ambient temperature	5 to 40 °C
Ambient relative humidity	20 to 80% (with no condensation)
Fast transient burst noise	2 kV or less (Power supply wire) 1 kV or less (Signal wire)
Electrostatic noise	4 kV or less
Base table	Use a base table that is at least 100 mm off the floor. Placing the Controller directly on the floor could allow dust penetration leading to malfunction.
Installation face	Inclination 0.5 ° or less (When installing vertically, the control unit may fall over if you touch them.)
Altitude	2000 m or less

If the controller must be used in an environment that does not fulfill the conditions mentioned above, take adequate countermeasures. For example, the controller may be enclosed in a cabinet with adequate ventilation and cooling.

- Install indoors, and place in a well-ventilated area.
- Keep away from direct sunlight.
- Keep away from radiation heat.
- Keep away from dust, oily mist, oil, salinity, metal powder or other contaminants.
- Keep away from water.
- Keep away from shocks or vibrations.
- Keep away from sources of electronic noise
- Keep away from strong electric or magnetic fields.

2.5.2 Installation

Install the Controller and Drive unit on a flat surface such as wall, floor, and Controller box in the direction shown in (A) to (C).

(A) Flat mounting

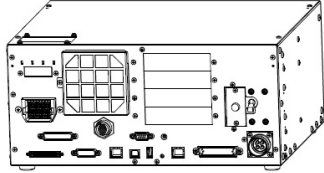

(B) Upright mounting

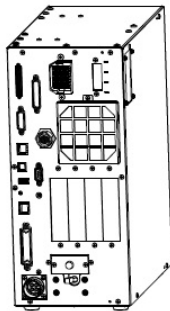

* The rubber foot needs to be replaced.

Attach the rubber foot with the flat side facing the controller. Remove the screws that interfere the rubber foot.

The size of the screw that secure the rubber foot is M4×8.

When replacing the rubber foot, be careful not to lose the screw. Also, do not use a screw of size other than M4×8.

(C) Rack mounting

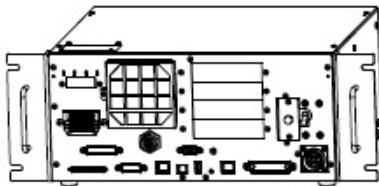

* A plate for rack mounting is required.

NOTE

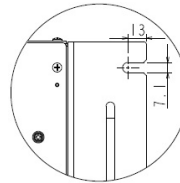
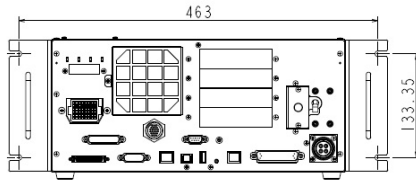

For Controller installation to the Controller box or the base table, process screw hole drilling as follows.



- Ensure the air flow around the supply and exhaust ports, and install the Controller while leaving space from other equipment or walls as below.

* Keep the space about 200 mm or more on the top to maintenance.

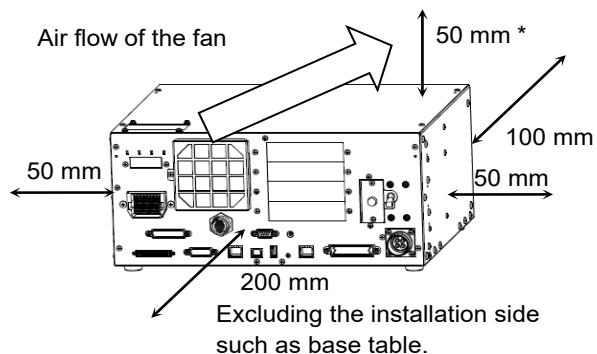
(A) Flat mounting, (C) Rack mounting



(Figure Flat mounting)

(B) Upright mounting

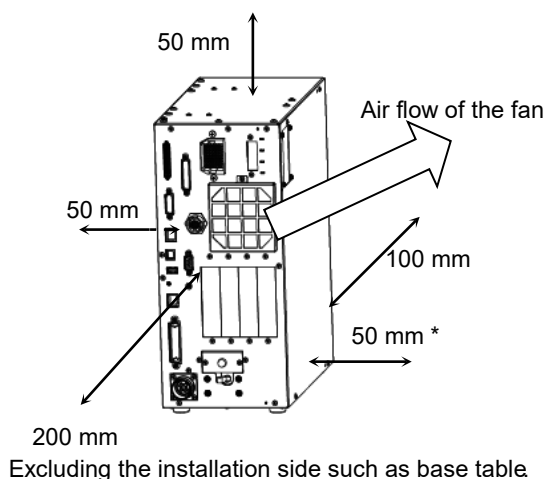

- Hot air with higher temperature than the ambient temperature (about 10 °C) comes out from the Controller. Make sure that heat sensitive devices are not placed near the outlet.
- Arrange the cables in front of the Controller so that you can pull the Controller forward.

2.5.3 Wall Mounting Option

The Controller has a wall mounting option. For more information, please contact the supplier of your region.

Controller outer dimensions when using the wall mounting option

Dimensions of the mounting holes for the wall

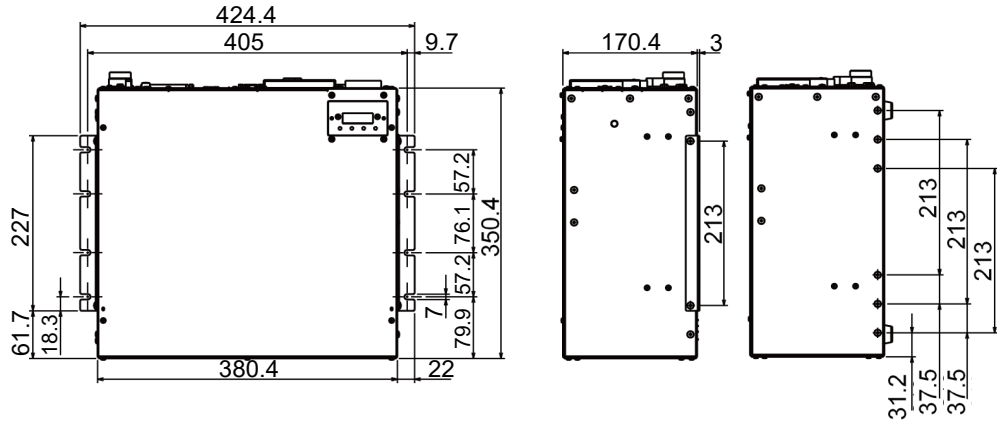

(Unit: mm)

Ensure the air flow around the supply and exhaust ports, and install the Controller while leaving space from other equipment or walls as below.

* Keep the space about 200 mm or more on the top to maintenance.

Wall mounting with the front side down

Wall mounting with the front side up

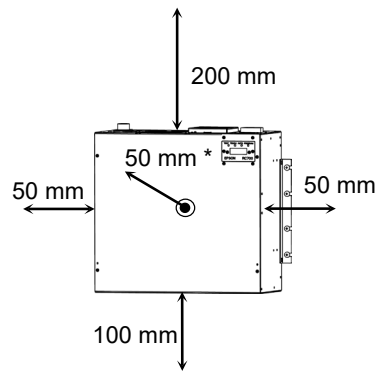
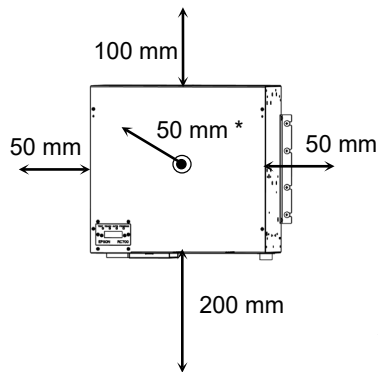

2.6 Designing a Safe Robot System

It is important to operate robots safely. It is also important for robot users to give careful consideration to the safety of the overall robot system design.

This section summarizes the minimum conditions that should be observed when using EPSON robots in your robot systems.

Please design and manufacture robot systems in accordance with the principles described in this and the following sections.

2.6.1 Environmental Conditions

Carefully observe the conditions for installing robots and robot systems that are listed in the “Environmental Conditions” tables included in the manuals for all equipment used in the system.

2.6.2 System Layout

When designing the layout for a robot system, carefully consider the possibility of error between robots and peripheral equipment. Emergency stops require particular attention, since a robot will stop after following a path that is different from its normal movement path. The layout design should provide enough margins for safety. Refer to the manuals for each robot, and ensure that the layout secures ample space for maintenance and inspection work.

When designing a robot system to restrict the area of motion of the robots, do so in accordance with the methods described in each Manipulator manual. Utilize both software and mechanical stops as measures to restrict motion.

Install the emergency stop switch at a location near the operation unit for the robot system where the operator can easily press and hold it in an emergency.

Do not install the Controller at a location where water or other liquids can leak inside the Controller. In addition, never use liquids to clean the Controller.

For safe lockouts during service and maintenance, disconnectors should be placed outside the safeguard wherever possible.

2.6.3 Disabling Power to the System using lock out / tag out

The power connection for the Robot Controller should be such that it can be locked and tagged in the off position to prevent anyone from turning ON power while someone else is in the safeguarded area.

UL-compliant Controller (RC700-D-UL):

Perform lockout using the following procedure.

A padlock for lockout should be prepared by users.

Applicable shackle diameter: 4.0 to 6.5 mm

- (1) Remove a fixing screw of the lockout bracket A by hand.

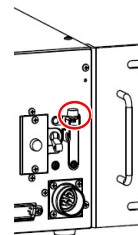

- (2) Rotate the lockout bracket A.
- (3) Set the screw removed in the step (1) to the lockout bracket B so as not to lose it.

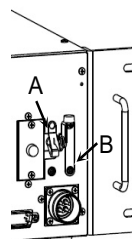

- (4) Put a padlock through the holes of the lockout brackets A and B to lock.

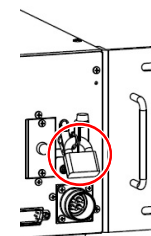

2.6.4 End Effector Design

Provide wiring and piping that will prevent the robot end effector from releasing the object held (the work piece) when the robot system power is shut off.

Design the robot end effector such that its weight and moment of inertia do not exceed the allowable limits. Use of values that exceed the allowable limits can subject the robot to excessive loads. This will not only shorten the service life of the robot but can lead to unexpectedly dangerous situations due to additional external forces applied to the end effector and the work piece.

Design the size of the end effector with care, since the robot body and robot end effector can interfere with each other.

2.6.5 Peripheral Equipment Design

When designing equipment that removes and supplies parts and materials to the robot system, ensure that the design provides the operator with sufficient safety. If there is a need to remove and supply materials without stopping the robot, install a shuttle device or take other measures to ensure that the operator does not need to enter a potentially dangerous zone.

Ensure that an interruption to the power supply (power shutoff) of peripheral equipment does not lead to a dangerous situation. Take measures that not only prevent a work piece held from being released as mentioned in “End effector Design” but that also ensure peripheral equipment other than the robots can stop safely. Verify equipment safety to ensure that, when the power shuts off, the area is safe.

2.6.6 Remote Control

For the safety of the overall system, however, safety measures are needed to eliminate the risks associated with the start-up and shutdown of peripheral equipment by remote control.

With this product, the robot system can be operated remotely by assigning a remote function to the controller I/O. To prevent danger from unintended remote control, the remote function will not be enabled without proper settings. Also when remote is valid, motion command execution and I/O output are available only from remote.

2.6.7 Emergency Stop

Each robot system needs equipment that will allow the operator to immediately stop the system's operation. Install an emergency stop device that utilizes emergency stop input from the Controller and all other equipment.

Use the emergency switch which has safety function more than PLd.

The safety function of Emergency Stop Input: Category 3, PLd (reference ISO13849-1 2015)

NOTE  The Stop category of Emergency Stop Input: Category 1 (reference IEC60204-1 2016)
 Test pulse cannot be used with the emergency stop input of this model.

The controller is equipped with an emergency stop input terminal. If the normally closed emergency stop circuit is broken, the control is stopped. Then the power supplied to all motors will be shut off.

The emergency stop circuit should also remove power from all external components that must be turned off during an emergency. Do not assume that the robot controller will turn off all outputs if configured to. For example, if an I/O card is faulty, the controller cannot turn off a component connected to an output. The emergency stop on the controller is hardwired to remove motor power from the robot, but not external power supplies.

However, do not press emergency stop switch during normal operation. Pressing emergency stop switch may cause collision with the peripheral equipment because the operation path of manipulator until stops is different from normal operation path.

Do not press the Emergency Stop switch unnecessarily while the Robot is operating. Pressing the switch during the operation makes the brakes work. This will shorten the life of the brakes due to the worn friction plates.

Normal brake life cycle: About 2 years (when the brakes are used 100 times/day)

However, the rough normal relay life is approximately 20,000 times. If you press the emergency stop switch unnecessarily, the life of the relay will be shortened.

Also, the Emergency Stop during operation applies impact on the reduction gear unit, and it may result in the short life of the reduction gear unit.

Following may result in the short life when stopping the operation by pressing emergency switch in the manipulator working properly.

- Brakes
- Reduction gear unit

To place the robot system in emergency mode during normal operation, press the Emergency Stop switch while the Manipulator is not moving.
Refer to the Controller manual for instructions on how to wire the Emergency Stop switch circuit.

Do not turn OFF the Controller while the Manipulator is operating.

If the Manipulator is stopped by turning OFF the Controller while it is operating, the following problems may occur.

- Reduction of the life and damage of the reduction gear unit
- Position gap at the joints

In addition, if the Controller was forced to be turned OFF by blackouts and the like while the Manipulator is operating, make sure to check the following points after power restoration.

- Whether or not the reduction gear is damaged
- Whether or not the joints are in their proper positions

If there is a position gap, perform calibration.

Before using the Emergency Stop switch, be aware of the followings.

- The Emergency Stop (E-STOP) switch should be used to stop the Manipulator only in case of emergencies.
- To stop the Manipulator operating the program except in emergency, use Pause (halt) or STOP (program stop) commands.
Pause and STOP commands do not turn OFF the motors. Therefore, the brake does not function.
- For the Safeguard system, do not use the circuit for E-STOP.

To check brake problems, refer to the following manuals.

Manipulator Manual Inspection Point - Inspection Item

Stopping distance in emergency

The Manipulator in operation cannot stop immediately after the Emergency Stop switch is pressed. In addition, stopping time and stopping distance vary by following factors:

- Hand weight WEIGHT Setting ACCEL Setting
- Workpiece weight SPEED Setting Posture etc.

For stopping time and stopping distance, refer to the following manual:

Manipulator Manual

Appendix B. Stopping Time and Stopping Distance in Emergency

2.6.8 Safeguard

To ensure safe operation, install a safety system using safety doors, light curtains, safety floor mats, etc.

When installing the safeguard system, strictly observe the following points:

Install the safeguard which has safety function more than PLd.

Safety function of Safety Door Input: Category 3, PLd (reference ISO13849-1 2015)

Stop category of Safety Door Input: Category 1 (reference IEC60204-1 2016)

NOTE



Test pulse cannot be used with the safeguard input of this model.

Refer to each manipulator manual and install the safeguard system outside the maximum space. Carefully consider the size of the end effector and the work pieces to be held so that there will be no error between the moving parts and the safeguard system.

Manufacture the safeguard system to withstand calculated external forces (forces that will be added during operation and forces from the surrounding environment).

When designing the safeguard system, make sure that it is free of sharp corners and projections, and that the safeguard system itself is not a hazard.

Make sure that the safeguard system can only be removed by using a tool.

There are several types of safeguard devices, including safety doors, safety barriers, light curtains, safety gates, and safety floor mats. Install the interlocking function in the safeguard device. The safeguard interlock must be installed so that the safeguard interlock is forced to work in case of a device failure or other unexpected accident. For example, when using a door with a switch as the interlock, do not rely on the switch's own spring force to open the contact. The contact mechanism must open immediately in case of an accident.

Connect the interlock switch to the safeguard input of the drive unit's EMERGENCY connector. The safeguard input informs the robot controller that an operator may be inside the safeguard area. When the safeguard input is activated, the robot stops immediately and enters pause status, as well as either operation-prohibited status or restricted status (low power status).

Make sure to install the safeguard interlock in the area where workers steps in the inside of safeguard.

Make sure the safeguard interlock is locked once it is activated, until it is intentionally released. EMERGENCY connector of the Controller has latch release input to release latch of safeguard interlock. Install a switch to release latch of safeguard interlock outside of the safety door, and wire to latch release input.

 WARNING	<ul style="list-style-type: none"> ■ It is dangerous to allow someone else to release the safeguard interlock by mistake while the operator is working inside the safeguarded area. To protect the operator working inside the safeguarded area, take measures to lock out and tag out the latch-release switch. ■ The EMERGENCY connector on the controller has a safeguard input circuit to connect the safety device interlock switch. To protect operators working near the robot, be sure to connect the interlock switch and make sure that it works properly.
---	--

When a closed safeguard is open during robot motion, the safeguard interlock function operates. The robot stops immediately and enters into pause state. Then, all robot motors are turned OFF. The descriptions below explain how the safeguard input works.

Safeguard open : The robot stops immediately, motors are turned OFF, and further operation is impossible until either the safeguard is closed or TEACH or TEST mode is turned ON and the enable circuit is engaged.

Safeguard closed : The robot can automatically operate in unrestricted (high power) state.

Do not open the safeguard unnecessarily while motor is ON. Frequent safeguard inputs affect the life of the relay.

Rough normal relay life: Approximately 20,000 times

For the safeguard, do not use the E-STOP circuit.

For details of wiring instructions, refer to the “11. Emergency”.

For details of the safeguard, refer to the following manuals as well.

2.7.1 Connection to EMERGENCY Connector

Stopping distance when the safeguard is opened

The Manipulator in operation cannot stop immediately after the safeguard is opened. In addition, stopping time and stopping distance vary by following factors:

Hand weight	WEIGHT Setting	ACCEL Setting
Workpiece weight	SPEED Setting	Posture etc.

For stopping time and stopping distance of the Manipulator refer to the following manual.

Manipulator Manual

Appendix C: Time and Distance of Free Running When the Safeguard is Opened.

2.6.9 Presence Sensing Device

The above mentioned safeguard interlock is a type of presence sensing device, since it indicates the possibility of somebody being inside the safeguard system. When separately installing a presence sensing device, however, perform a satisfactory risk assessment and pay thorough attention to its dependability.

Here are precautions that should be noted:

- Design the system so that when the presence sensing device is not activated or a dangerous situation still exists that no personnel can go inside the safeguard area or place their hands inside it.
- Design the presence sensing device so that regardless of the situation the system operates safely.
- If the robot stops operating when the presence sensing device is activated, it is necessary to ensure that it does not start again until the detected object has been removed. Make sure that the robot cannot automatically restart.

2.6.10 Resetting the Safeguard

Ensure that the robot system can only be restarted through careful operation from outside the safeguarded system. The robot will never restart simply by resetting the safeguard interlock switch. Apply this concept to the interlock gates and presence sensing devices for the entire system.

2.6.11 Robot Operation Panel

Ensure that the robot system can be operated from outside of the safeguard.

2.7 Connecting

2.7.1 Connection to EMERGENCY Connector



The details of safety requirements for this section are described in Safety Manual. Please refer to them to keep the robot system safe.

 CAUTION	<ul style="list-style-type: none"> Not only when turning ON the device, but also changing use environment such as add options or replace parts for maintenance, make sure that the emergency stop or safety door work properly.
-------------	--

Connect a safeguard switch or Emergency Stop switch to the EMERGENCY connector of the Controller for safety.

When nothing is connected to the EMERGENCY connector, Controller does not operate normally.

 CAUTION	<ul style="list-style-type: none"> Before connecting the connector, make sure that the pins are not bent. Connecting with the pins bent may damage the connector and result in malfunction of the robot system.
-------------	--

EMERGENCY connector

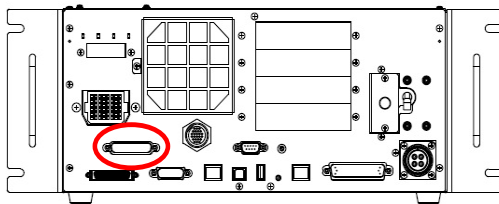

Safety Door Switch and Latch Release Switch

The EMERGENCY connector has input terminals for the Safety Door switch and the Emergency Stop switch. Be sure to use these input terminals to keep the system safe.

Connector	Standard
EMERGENCY connector (Controller side)	D-sub25 Pin (male) Screwlock #4-40

Safety Door Switch



WARNING

- The interlock of the Safety Door must be functioning when the robot system is operated. Do not operate the system under the condition that the switch cannot be turned ON/OFF (e.g. covering the switch with tape). Operating the robot system when the switch is not functioning properly is extremely hazardous and may cause serious safety problems as the Safety Door input cannot fulfill its intended function.

In order to maintain a safe working zone, a safeguard must be set up around the Manipulator. The safeguard must have an interlock switch at the entrance to the working zone. The Safety Door that is described in this manual is one of the safeguards and an interlock of the Safety Door is called a Safety Door switch. Connect the Safety Door switch to the Safety Door input terminal on the EMERGENCY connector.

The Safety Door switch has safety features such as temporary hold-up of the program or the operation-prohibited status that are activated whenever the Safety Door is opened.

Observe the following in designing the Safety Door switch and the Safety Door.

- For the Safety Door switch, select a switch that opens as the Safety Door opens, and not by the spring of the switch itself.
- The signal from the Safety Door (Safety Door input) is designed to input to two redundant signals. If the signals at the two inputs differ by two seconds or more, the system regards it as a critical error. Therefore, make sure that the Safety Door switch has two separate redundant circuits and that each connects to the specified pins at the EMERGENCY connector on the Controller.
- The Safety Door must be designed and installed so that it does not close accidentally.

Latch Release Switch

Software latches state of safety door opened/closed and state of TEACH mode.

The EMERGENCY connector has an input terminal for a latch release switch that cancels the latched conditions.

Open :The latch release switch latches conditions that the safety door is open or the operation mode is "TEACH".

Closed :The latch release switch releases the latched conditions.



NOTE When the latched TEACH mode is released while the safety door is open, the status of Manipulator power is operation-prohibited because the safety door is open at that time. To execute a Manipulator operation, close the safety door again, and then close the latch release input.

Checking Latch Release Switch Operation

Refer to 4.2 Development PC and Controller Connection and connect the development PC and Controller before checking the function.

After connecting the safety door switch and latch release switch to the EMERGENCY connector, be sure to check the switch operation for safety by following the procedures described below before operating the Manipulator.

- (1) Turn ON the Controller while the safety door is open in order to boot the Controller software.
- (2) Make sure that “Safety” is displayed on the Epson RC+ status bar.
- (3) Close the safety door, and turn ON the switch connecting to the latch release input. Make sure that the “Safety” is dimmed on the status bar.

The information that the safety door is open can be latched by software based on the latch release input condition. To cancel the condition, close the safety door, and then close the safety door latch release input.

Open : The latch release switch latches condition that the safety door is open.

Closed : The latch release switch does not latch the condition that the safety door is open.



The latch release input also functions to acknowledge the change of TEACH mode.

In order to change the latched condition of the TEACH mode, turn the mode selector key switch on the Teach Pendant to “Auto”. Then, close the latch release input.

Emergency Stop Switch

If it is desired to create an external Emergency Stop switch in addition to the Emergency Stop on the Teach Pendant, make sure to connect the Emergency Stop switch to the Emergency Stop input terminal on the EMERGENCY connector.

The Emergency Stop switch connected must comply with the related safety standards (such as IEC60947-5-5) and the following:

- It must be a push button switch that is “normally closed”.
- A button that does not automatically return or resume.
- The button must be mushroom-shaped and red.
- The button must have a double contact that is “normally closed”.



The signal from the Emergency Stop switch is designed to use two redundant circuits.

If the signals at the two circuits differ by two seconds or more, the system recognizes it as a critical error. Therefore, make sure that the Emergency Stop switch has double contacts and refer to the following to connect.

Circuit Diagrams – Controller

Checking Emergency Stop Switch Operation



NOTE

Refer to *4.2 Development PC and Controller Connection* and connect the development PC and Controller before checking the function.

Once the Emergency Stop switch is connected to the EMERGENCY connector, continue the following procedure to make sure that the switch functions properly.

- (1) Turn ON the Controller to boot the Controller software while pressing the Emergency Stop switch.
- (2) Make sure that the seven-segment LED on the Controller displays as shown below.



- (3) Make sure that “EStop” is displayed on the Epson RC+ status bar.
- (4) Release the Emergency Stop Switch.
- (5) Execute the RESET command.

EPSON
RC+ 7.0

Select Epson RC+-[Tools]-[Robot Manager]-[Control Panel] and click the <Reset> button to execute the RESET command.

Epson
RC+ 8.0

Select Epson RC+-[Tools]-[Robot Manager] and click the <Reset> button to execute the RESET command.

- (6) Make sure that the LED shown below is turned OFF and that “E-Stop” is dimmed on the main window status bar.



Pin Assignments

The EMERGENCY connector pin assignments are as follows:

Pin No.	Signal	Function	Pin No.	Signal	Function
1	ESW11	Emergency Stop switch contact (1) *3	14	ESW21	Emergency Stop switch contact (2) *3
2	ESW12	Emergency Stop switch contact (1) *3	15	ESW22	Emergency Stop switch contact (2) *3
3	ESTOP1+	Emergency Stop circuit 1 (+) *4	16	ESTOP2+	Emergency Stop circuit 2 (+) *4
4	ESTOP1-	Emergency Stop circuit 1 (-) *4	17	ESTOP2-	Emergency Stop circuit 2 (-) *4
5	Not used	*1	18	SDLATCH1	Safety Door Latch Release
6	Not used	*1	19	SDLATCH2	Safety Door Latch Release
7	SD11	Safety Door input (1) *2	20	SD21	Safety Door input (2) *2
8	SD12	Safety Door input (1) *2	21	SD22	Safety Door input (2) *2
9	24V	+24V output	22	24V	+24V output
10	24V	+24V output	23	24V	+24V output
11	24VGND	+24V GND output	24	24VGND	+24V GND output
12	24VGND	+24V GND output	25	24VGND	+24V GND output
13	Not used				

- *1 Do not connect anything to these pins.
- *2 A critical error occurs if the input values from the Safety Door 1 and Safety Door 2 are different for two or more seconds. They must be connected to the same switch with two sets of contacts.
- *3 A critical error occurs if the input values from the Emergency Stop switch contact 1 and Emergency Stop switch contact 2 are different for two or more seconds. They must be connected the same switch with two sets of contacts.
- *4 Do not apply reverse voltage to the Emergency Stop circuit.

Emergency Stop switch output rated load	+30 V 0.3 A or under	1-2, 14-15 pin
Emergency Stop rated input voltage range Emergency Stop rated input current	+24 V ±10% 37.5 mA ±10% / +24V input	3-4, 16-17 pin
Safety Door rated input voltage range Safety Door rated input current	+24 V ±10% 10 mA / +24 V input	7-8, 20-21 pin
Latch Release rated input voltage range Latch Release rated input current	+24 V ±10% 10 mA / +24 V input	18-19 pin



The total electrical resistance of the Emergency Stop switches and their circuit should be 1 Ω or less.

 CAUTION	<ul style="list-style-type: none"> ■ The 24 V output is for emergency stop. Do not use it for other purposes. Doing so may result in system malfunction. ■ Do not apply reverse voltage to the Emergency Stop circuit. Doing so may result in system malfunction.
--------------------	---

Circuit Diagrams – Controller

Example 1: External emergency stop switch typical application

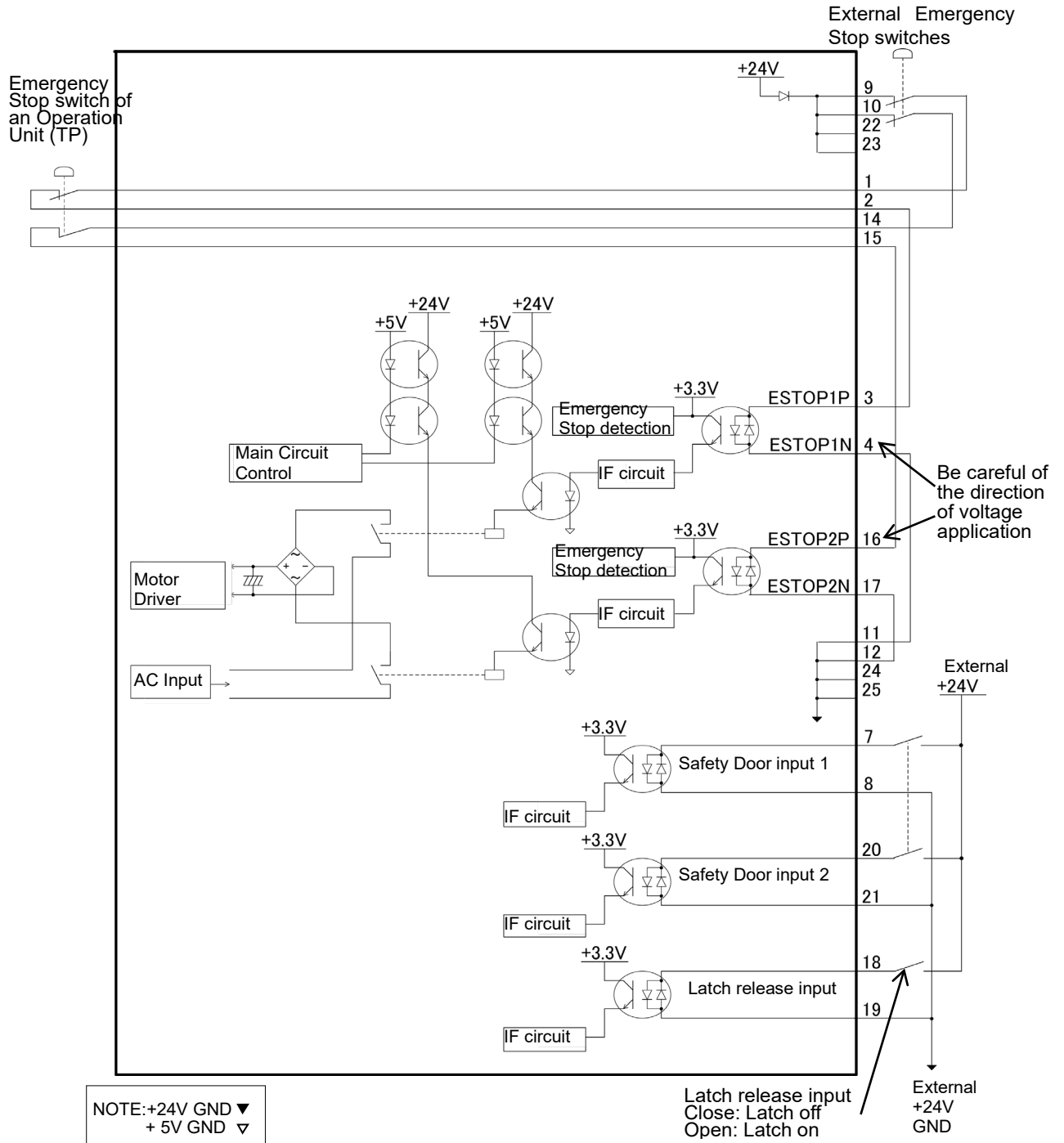

Example 2: External safety relay typical application

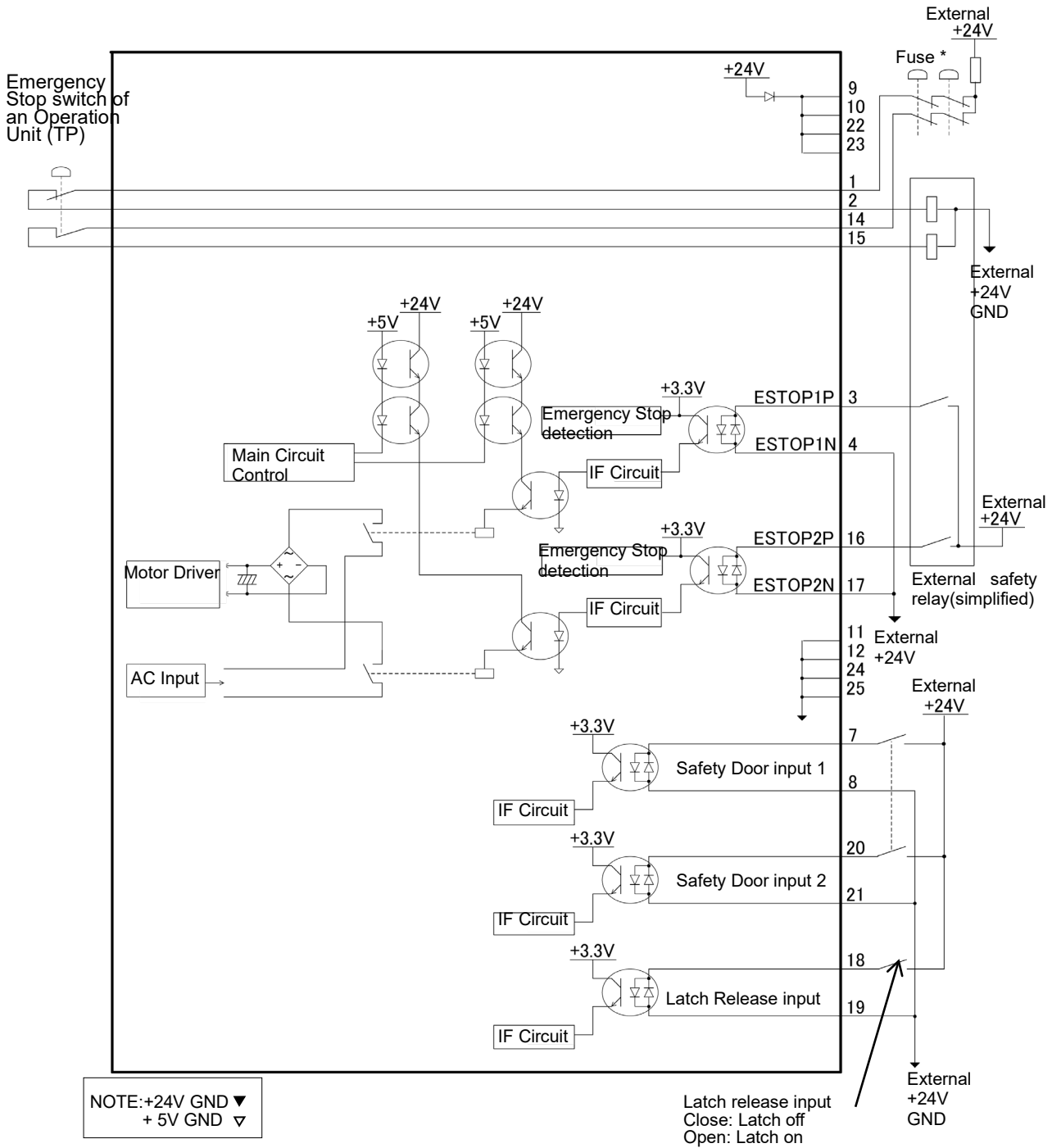

* To protect Emergency Stop Circuit, use the fuse that is 0.4A or under and matches amount of external safety relay.

2.7.2 Power Supply

Specification

Ensure that the power meets the following specifications.

Item	Specification
Voltage	200 to 240 VAC (Input voltage should be within $\pm 10\%$ of the rated voltage.)
Phase	Single phase
Frequency	50/60 Hz
Momentary Power Interrupt	10 ms or less
Rated Capacity	Maximum : 2.5 kVA Actual power consumption depends on the model, motion, and load of the Manipulator. For approximate power consumption of each model, refer to the following values. GX4: 1.2 kVA GX8: 2.2 kVA Refer to the Manipulator manual for rated capacity of the Manipulator motor.
Max. load current	Max : 12.0 A Actual Value depends on the model, motion, and load of the Manipulator. For approximate power consumption of each model, refer to the following values. GX4: 6.0 A GX8: 12.0 A
Short-circuit current rating	5 kA
Maximum Supply Source Impedance	0.32 Ω
Inrush Current	When power is turned ON: Approx. 85 A (2 ms) When motor is ON : Approx. 75 A (2 ms)
Leakage Current	Less than 3.5 mA
Ground Resistance	TN Ground (100 Ω or less)

Install an earth leakage circuit breaker or a circuit breaker in the AC power cable line at 15 A or less rated electric current. Both should be a two-pole disconnect type. If you install an earth leakage circuit breaker, make sure to use an inverter type that does not operate by induction of a 10 kHz or more leakage current. If you install a circuit breaker, please select one that will handle the above mentioned “inrush current”. The power receptacle should be installed near the equipment and should be easily accessible.

AC Power Cable

	<ul style="list-style-type: none"> ■ Make sure that operations are done by a qualified personal. ■ Be sure to connect the earth wire (green/yellow) of the AC power cable to the earth terminal of the factory power supply. The equipment must be grounded properly at all times to avoid the risk of electric shock. ■ Always use a power plug or a disconnecting device for power connecting cable. Never connect the Controller directly to the factory power supply. ■ Select the plug or a disconnecting device which conform safety standards for nations.
---	---

When connecting the plug of the AC power cable to the Controller, insert until it clicks as shown in the figure below.



Following shows specification of power connection side.
Mount to the plug like following below.

Item	Specification
AC power wire (2 cables)	Black, Black
Ground wire	Green / Yellow
Cable length	3 m
Terminal	M4 round solderless terminal



2.7.3 Connecting Manipulator and Controller

Connecting Precautions

- | | | |
|----------------------|---|---|
| Before Connection | : | Before connecting the connector, make sure that the pins are not bent. Connecting with the pins bent may damage the connector and result in malfunction of the robot system. |
| Connecting procedure | : | Before performing any connecting procedure, turn OFF the Controller and related equipment, and then disconnect the power plug from the power source.
Performing any replacement procedure with the power ON is extremely hazardous and may result in electric shock and/or malfunction of the robot system. |
| Cable | : | Be sure to connect the cables properly. Do not allow unnecessary strain on the cables. (Do not put heavy objects on the cables. Do not bend or pull the cables forcibly.) The unnecessary strain on the cables may result in damage to the cables, disconnection, and/or contact failure. Damaged cables, disconnection, or contact failure is extremely hazardous and may result in electric shock and/or improper function of the robot system. |
| Connection | : | When connecting the Manipulator and the Controller, make sure that the serial numbers on each equipment match. Improper connection between the Manipulator and Controller may not only cause improper function of the robot system but also safety problems.
The serial number of supported Manipulator is labeled on the controller. |
| Wiring | : | Only authorized or certified personnel should be allowed to perform wiring.
Wiring by unauthorized or uncertified personnel may result in bodily injury and/or malfunction of the robot system. |
| For Clean-model | : | When the Manipulator is a Clean-model, use it with an exhaust system.
For details, refer to the Manipulator manual. |
| For Protected-model | : | Connect the power cable connection and the signal cable connector to the Manipulator immediately after the Manipulator installation. The Manipulator without connecting them may result in electric shock and/or malfunction of the robot system as it cannot ensure IP65. |

Connect the power connector and the signal connector of the M/C cables to the Controller.

2.8 Saving Default Status

The Controller is already setup with the purchased robot(s) at shipment. However, just in case, we recommend saving the default Controller status. A USB memory is necessary to save the Controller status.

For the procedure of Controller status storage, refer to Robot Controller: 8. Memory Port.

3. Power-ON

3.1 Power-ON Precautions

- Manipulator check : Before operating the Manipulator, make sure that all parts of the Manipulator are in place and have no external defects. Missing or defective parts may cause improper operation of the Manipulator. Improper operation of the Manipulator is extremely hazardous and may result in serious bodily injury and/or severe equipment damage to the robot system.
- Shipping bolts and jigs check before turning ON : Before turning ON the power after installation, be sure to remove the shipping bolts and jigs from the Manipulator. Turning ON the power while the shipping bolts and jigs are attached may result in equipment damage to the Manipulator.
- Power activation : Anchor the Manipulator before turning ON the power to or operating the Manipulator. Turning ON the power to or operating the Manipulator that is not anchored is extremely hazardous and may result in serious bodily injury and/or severe equipment damage to the robot system as the Manipulator may fall down
- Initial operation : Be sure to check at low speed when operating the Manipulator for the first time or executing the operation program for the first time. When it is suddenly operated at high speed, it may not be able to respond to unexpected movements and may cause extremely dangerous, serious injury or serious damage such as collision with the Manipulator.
- When supplying the power again : When supplying the power to the Controller again, turn OFF the Controller and wait for 5 seconds or more. Then, turn ON the Controller again.

3.2 Power ON Procedure

- (1) Check the M/C power cable connection.
- (2) Check the M/C signal cable connection.
- (3) Check the EMERGENCY connector connection.
- (4) Connect the TP bypass plug to the TP port of the Robot Controller.
- (5) Connect the AC power cable to the power supply socket.
- (6) Turn ON the POWER switch of the Controller.

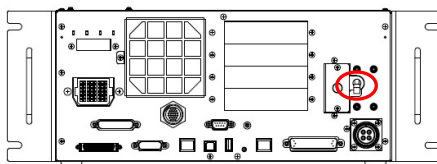

- (7) If the Controller starts up normally, the 7-segment LED blinks as shown below after approximately 30 seconds since the power is turned on.

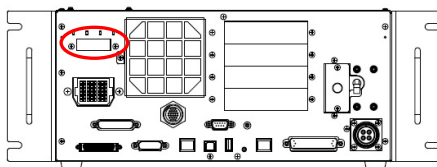
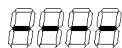

If an error is displayed, check connection in step (1) to (5) and turn ON the power again.

If an error is displayed after checking the connection, contact the supplier in your region.

4. First Step

This section indicates the procedure to install the development PC Epson RC+, and execute simple program after connecting the development PC and Controller with a USB.

Make sure that the Robot system is installed safely by following the description in “*Safety*” and “*Installation*”. Then, operate the Robot system in the following procedures.

4.1 Installing Epson RC+ Software

The Epson RC+ software needs to be installed on your development PC.

For the software installation procedure, refer to the following manual.

Epson RC+ User's Guide

4.2 Development PC and Controller Connection

Connect the development PC and the USB port for connection (USB B series connector).

The USB port of development PC for connection (USB B series connector).

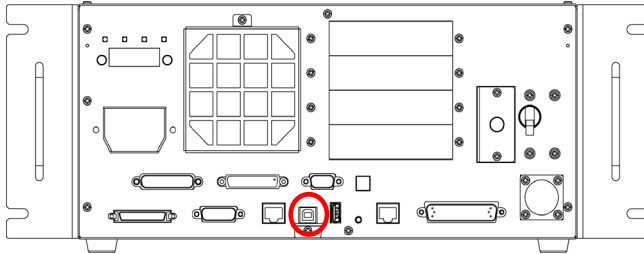

NOTE



- For other details of development PC and Controller connection, refer to *Epson RC+ User's Guide: [PC to Controller Communications] Command (Setup Menu)*.
- For RC700-D be sure to install the Epson RC+ to the development PC first, then connect the development PC and RC700-D with the USB cable.

If RC700-D and the development PC are connected without installing the Epson RC+ to the development PC, [Add New Hardware Wizard] appears. If this wizard appears, click the <Cancel> button.

4.2.1 About Development PC Connection USB Port

Development PC connection port supports following USB.

- USB2.0 HighSpeed/FullSpeed (Speed auto selection, or FullSpeed mode)
- USB1.1 FullSpeed

Interface Standard: USB specification Ver.2.0 compliant
(USB Ver.1.1 upward compatible)

Connect the Controller and development PC by a USB cable to develop the robot system or set the Controller configuration with the Epson RC+ software installed in the development PC.

Development PC connection port supports hot plugging. Insertion and removal of the cables while the power of the development PC and the Controller are ON is available. However, the Manipulator stops when the USB cable is removed while the Controller and the development PC are connected.

4.2.2 Precaution

When connecting the development PC and the Controller, make sure of the following.

- Connect the development PC and the Controller with 5 m or shorter USB cable. Do not use the USB hub or extension cable.
- Make sure that no other devices except development PC is used for development PC connection port.
- Use PC or USB cable that supports USB2.0 HighSpeed mode to operate in USB2.0 HighSpeed mode.
- Do not pull or bend the cable strongly.
- Do not allow unnecessary strain on the cable.
- When development PC and the Controller is connected, do not insert or remove other USB devices from the development PC. Connection with the Controller may disconnect.

4.2.3 Software Setup and Connection Check

The following is the steps of connecting the development PC and the Controller.

- (1) Make sure that Epson RC+ is installed on the Controller connected to the development PC.
(Install the software when it is not installed.)
- (2) Connect the development PC and the Controller by the USB cable.
- (3) Turn ON the Controller.
- (4) Start the software Epson RC+.
- (5) Select the Epson RC+ menu-[Setup]-[PC to Controller Communications] to display the [PC to Controller Communications] dialog box.

EPSON RC+ 7.0

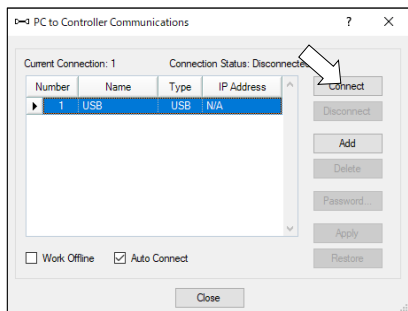

Epson RC+ 8.0

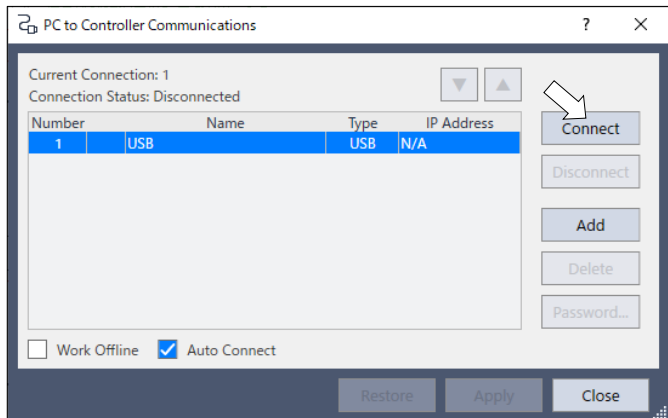

- (6) Select the “No.1 USB” and click the <Connect> button.

- (7) After development PC and the Controller connection is completed, “Connected” is displayed in the [Connection status:]. Make sure that “Connected” is displayed and click the <Close> button to close the [PC to Controller Communications] dialog box.

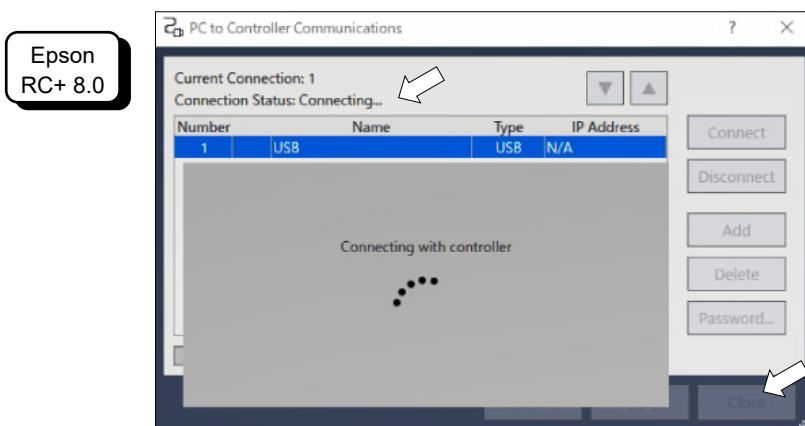
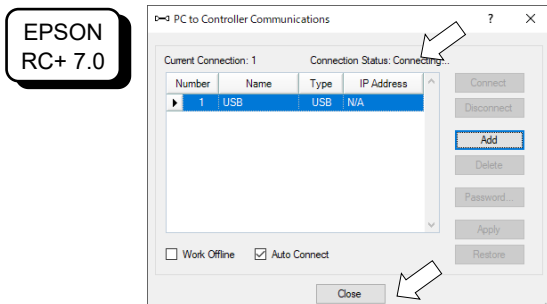

Connection of the development PC and the Controller is completed. Now robot system can be used from Epson RC+.

4.2.4 Backup the initial condition of the Controller

Backup the Controller data configured before shipment.

Project and system configuration backup procedure:

- (1) From the [Project] menu, select [Copy].
- (2) Change the [Destination Drive] to an arbitrary drive.
- (3) Click <OK>. The project will be copied to the external media.
- (4) From the [Tools] menu, select [Controller].
- (5) Click on the <Backup Controller> button.
- (6) Select the arbitrary drive.
- (7) Click <OK>. The system configuration will be backed up on the external media.

4.2.5 Disconnection of Development PC and Controller

Disconnection of the development PC and the Controller is indicated.

- (1) Select the Epson RC+ menu-[Setup]-[PC to Controller Communications] to display the [PC to Controller Communications] dialog box.
- (2) Click the <Disconnect> button.
Controller and the development PC is disconnected and USB cable can be removed.

 **NOTE** If the USB cable is removed while the Controller and the development PC are connected, the Manipulator stops. Be sure to click the <Disconnect> button in the [PC to Controller Communications] dialog box before removing the USB cable.

4.2.6 Moving the Robot to Initial Position

Robot can be operated by the following methods other than creating and executing the program.

- Manual operation
- Jog motion by the Teach Pendant
- Command execution from the Epson RC+
- Jog motion from the Epson RC+

This section explains about following methods.

- A: Manual operation
- B: Command execution from the Epson RC+
- C: Jog motion from the Epson RC+

A: Manual operation

Move the non-excited robot manually.

Manipulators can be moved manually by pressing the brake release switch when the brake release unit is connected. Joints with the brakes (Joints #3 and #4) can be moved manually while the break release switch on the Manipulator is being pressed with the Controller ON.

Also, Manipulators can be moved manually by releasing the electromagnetic brake from the command window of the Epson RC+.



- Normally, release the brake of joints one by one. Take extra care if you need to release the brakes of two or more joints simultaneously. Releasing the brakes of two or more joints simultaneously may result in hands or fingers being caught and/or equipment damage to or malfunction of the Manipulator as the arms of the Manipulator may move in unexpected directions.
- Be careful of the arm falling when releasing the brake. While the brake is being released, the Manipulator's arm falls by its own weight. The arm falling may result in hands or fingers being caught and/or equipment damage to or malfunction of the Manipulator.
- Before releasing the brake using the software, be sure to keep the Emergency Stop switch handy so that you can immediately press the Emergency Stop switch. Otherwise, you cannot immediately stop the arm falling due to an erroneous operation. The arm falling may cause equipment damage to and/or malfunction of the Manipulator.

(1) Start the Epson RC+.

Double click the Epson RC+ icon on the desktop. Or select from the Windows menu.

(2) Open the command window.

Epson RC+ menu-[Tool]-[Command Window]

(3) Execute the following command in [Command Window].

```
>Reset
```

```
>Brake Off, [Arm # (1 to 4) whose brake will be released]
```

Execute the following command to turn on the brake again.

```
>Brake On, [Arm # (1 to 4) whose brake will be turned on]
```

B: Command execution from Epson RC+

Move the robot by exciting the robot motors and executing the command.

Following explains the example of moving all joints to the 0 pulse positions by specifying the pulse for each joint.

(1) Start Epson RC+.

Double click the Epson RC+ icon on the desktop. Or select from the Windows menu.

(2) Open the command window.

Epson RC+ menu-[Tools]-[Command Window]

(3) Execute the following command in [Command Window].

```
>Motor On
```

```
>Go Pulse (0,0,0,0)
```

For position and posture of Manipulator at 0 pulse position, refer to Motion Range in the Manipulator manuals.

C: Jog motion from Epson RC+

Move the robot by exciting the motors and operating from the Jog & Teach window of Epson RC+.

- (1) Start Epson RC+.
 - Double click the Epson RC+ icon on the desktop. Or select from the Windows menu.
- (2) Create a new project.
 1. Epson RC+ menu-[Project]-[New Project]. [New Project] dialog box will be displayed.

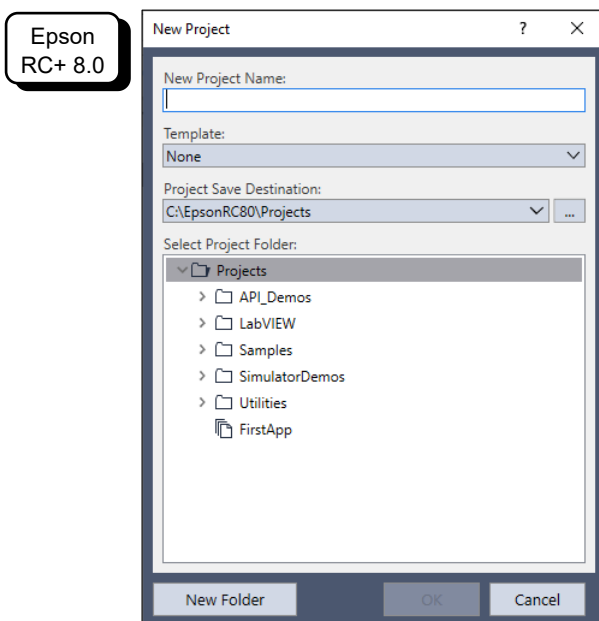
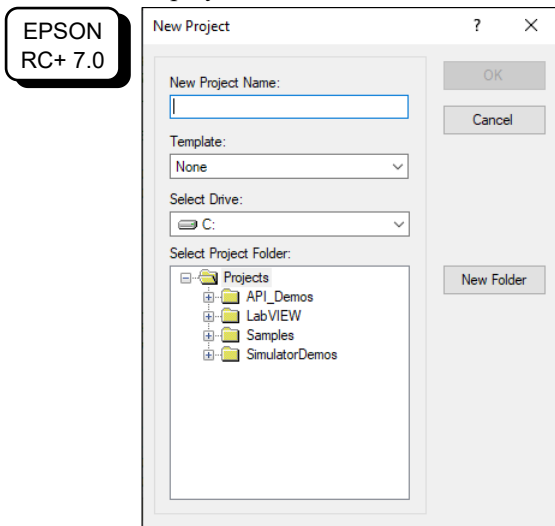

2. Enter the project name in [Project Name] box. (Ex: FirstApp)
 3. Click the <OK> button and create the new project.
- (3) Open the robot manager.
Epson RC+ menu-[Tools]-[Robot Manager].

(4) Turn ON the motors.

Check that the [Control Panel] tab is open. Click the <MOTOR ON> button.

EPSON
RC+ 7.0

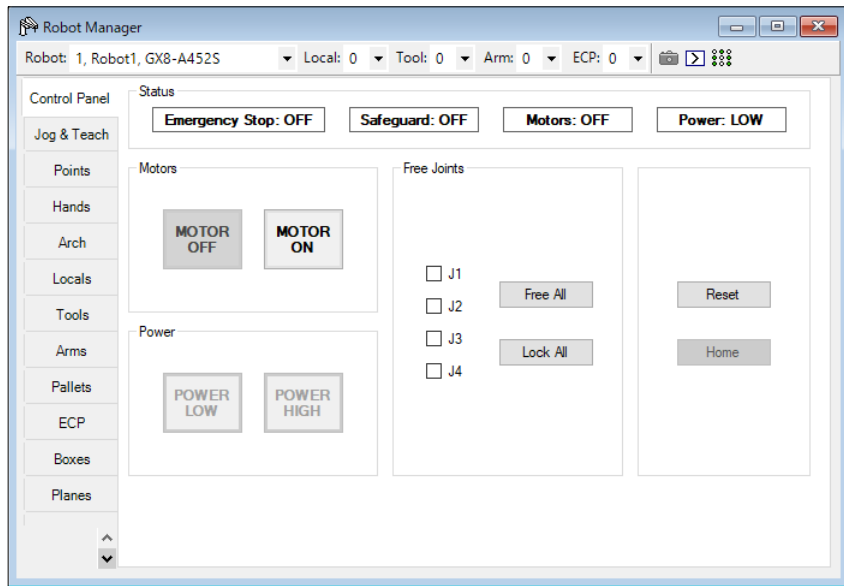

Epson
RC+ 8.0

Click the <Motor: Off> button.

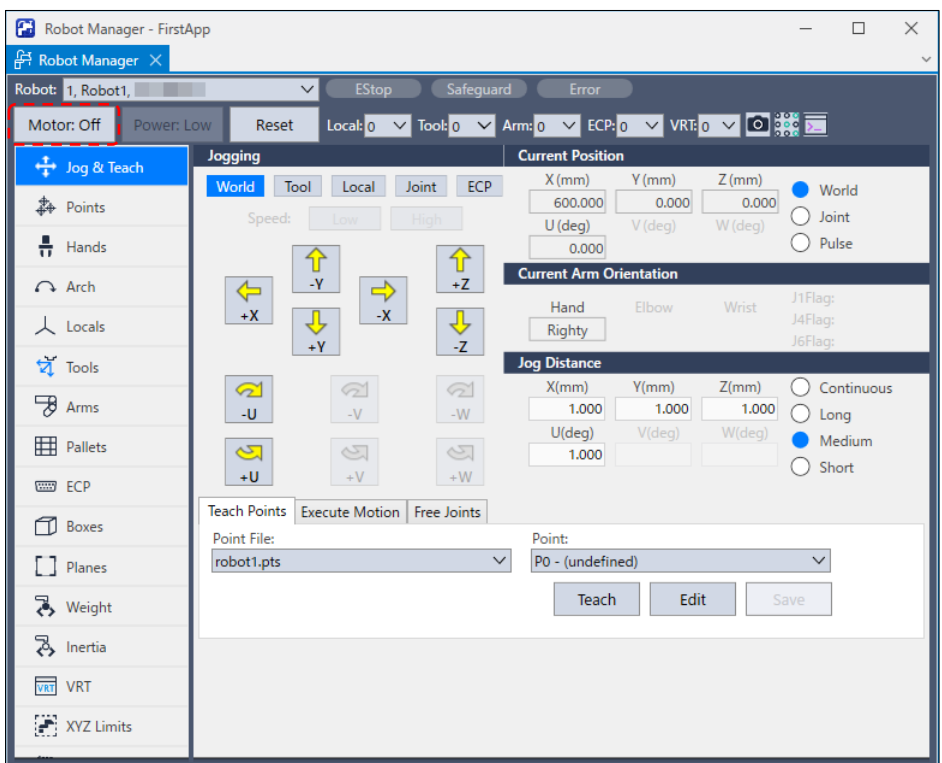

(5) Move the Manipulator with Jog motion.

1. Select [Jog & Teach] tab.

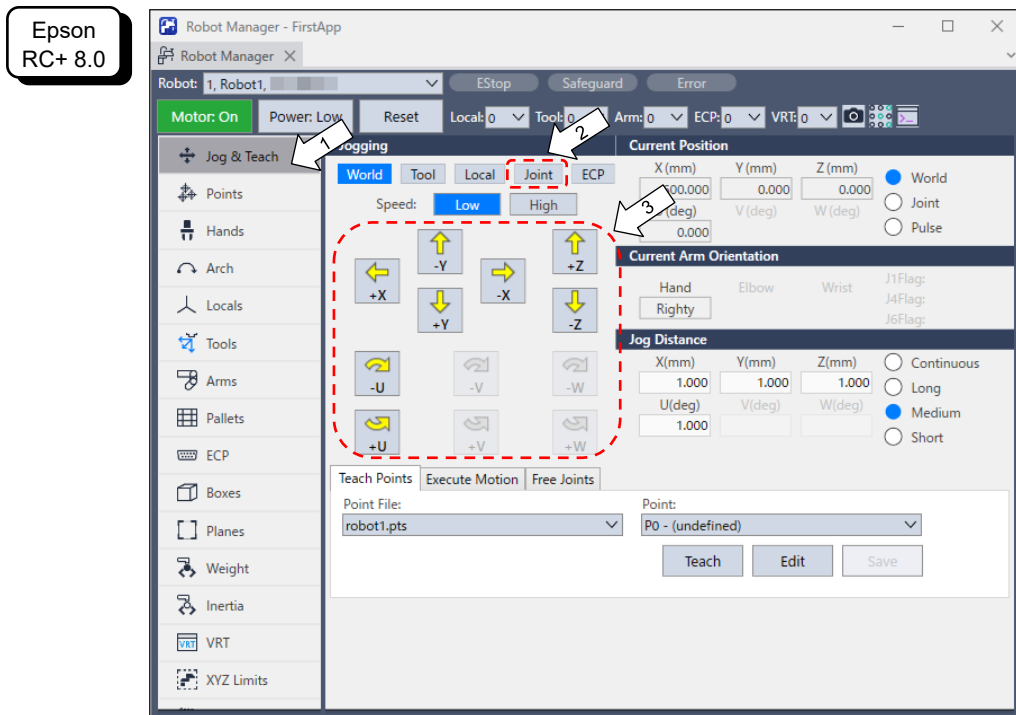
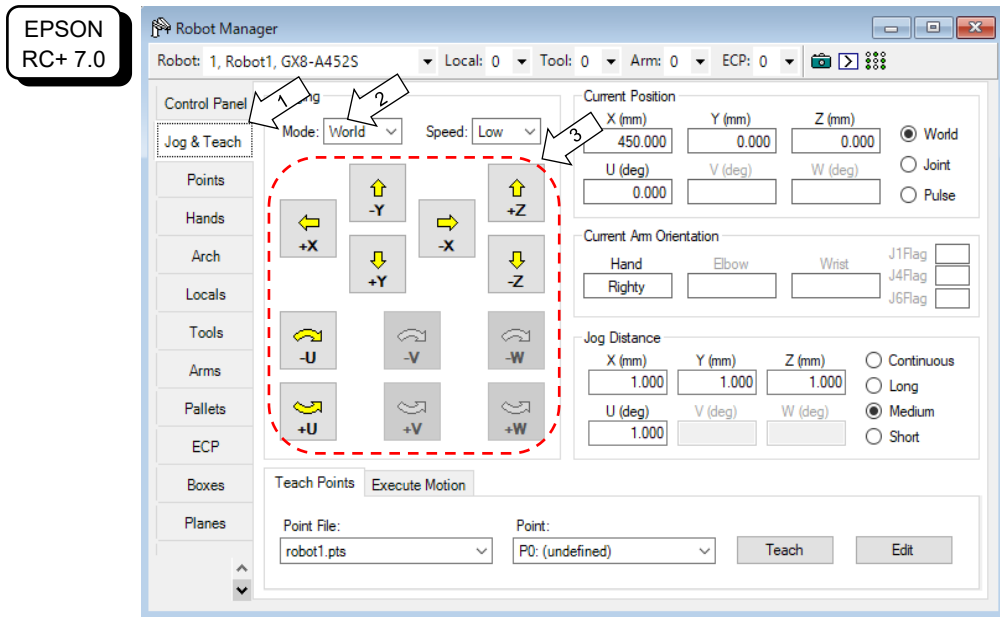

2. EPSON RC+ 7.0: Select “Joint” in [Jogging]-<Mode>.
Epson RC+ 8.0: Select “Joint” in [Jogging].
3. Move the Manipulator by joint by clicking J1-J4 jog keys.
Manipulator can be moved by setting to other modes or setting the jog distance.

4.3 Writing your first program

After installing the Controller, Manipulator, and Epson RC+ software on your PC, follow the instructions below to create a simple application program so that you will become more familiar with Epson RC+ development environment.

1. Start Epson RC+

Double-click the Epson RC+ icon on the desktop. Or select from the Windows menu.

2. Create a new project

- (1) Select [New] from the [Project] Menu. The [New Project] dialog box will be displayed.

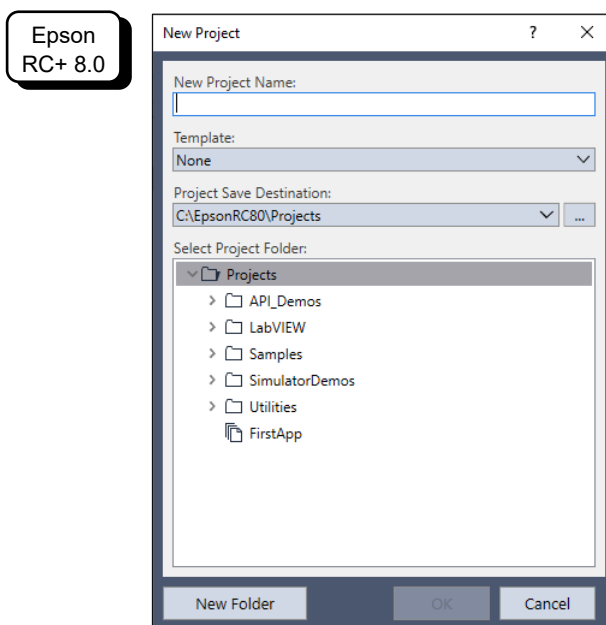
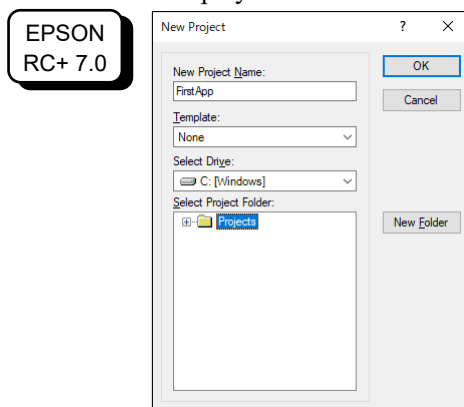

- (2) Type a project name in the [New Project Name] box.
(e.g. FirstApp)

- (3) Click <OK> to create the new project.

When the new project is created, a program called Main.prg is created.

The window titled Main.prg will be displayed with a cursor flashing in the upper left corner.

Now you are ready to start entering your first program.

3. Edit the program

Type the following program lines in the Main.prg edit window.

```
Function main  
  Print "This is my first program."  
Fend
```

EPSON
RC+ 7.0

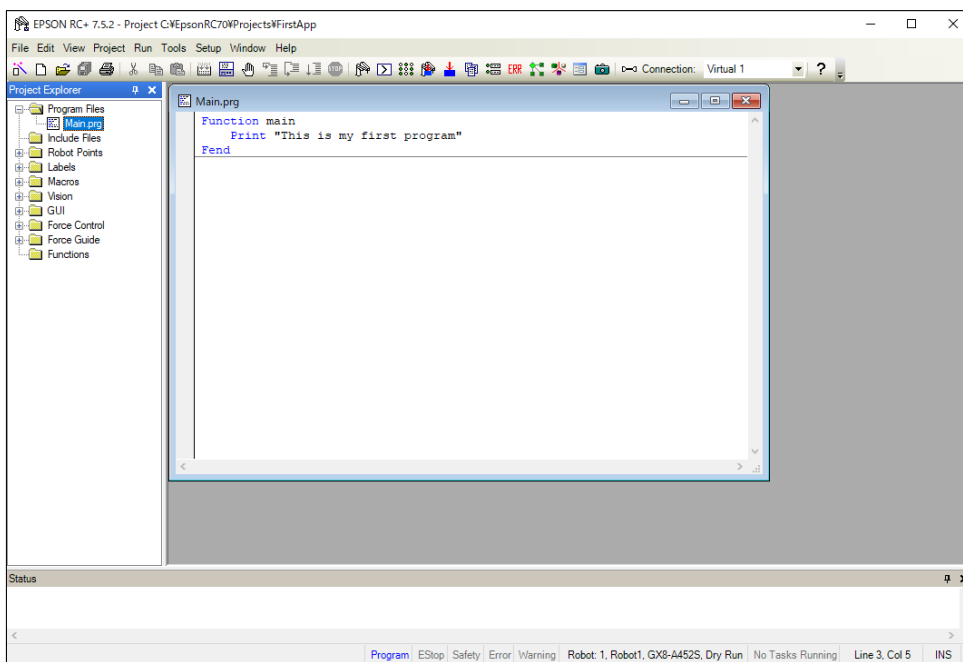

Epson
RC+ 8.0

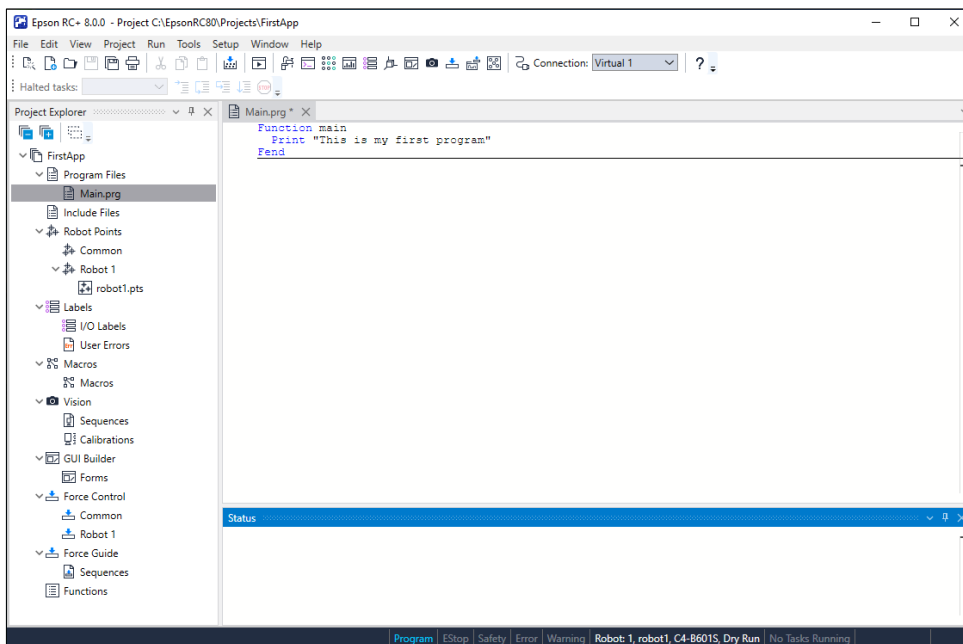

4. Run the program

- (1) Press F5 to run the program. (F5 is the hot key for the [Run Window] selection of the [Run] Menu). You will see the Status window located at the bottom of the main window showing the build operation status.
- (2) During project build, your program is compiled and linked. Then communications are established with the Controller and project files are sent to the Controller. If there are no errors during build, the Run window will appear.

EPSON
RC+ 7.0

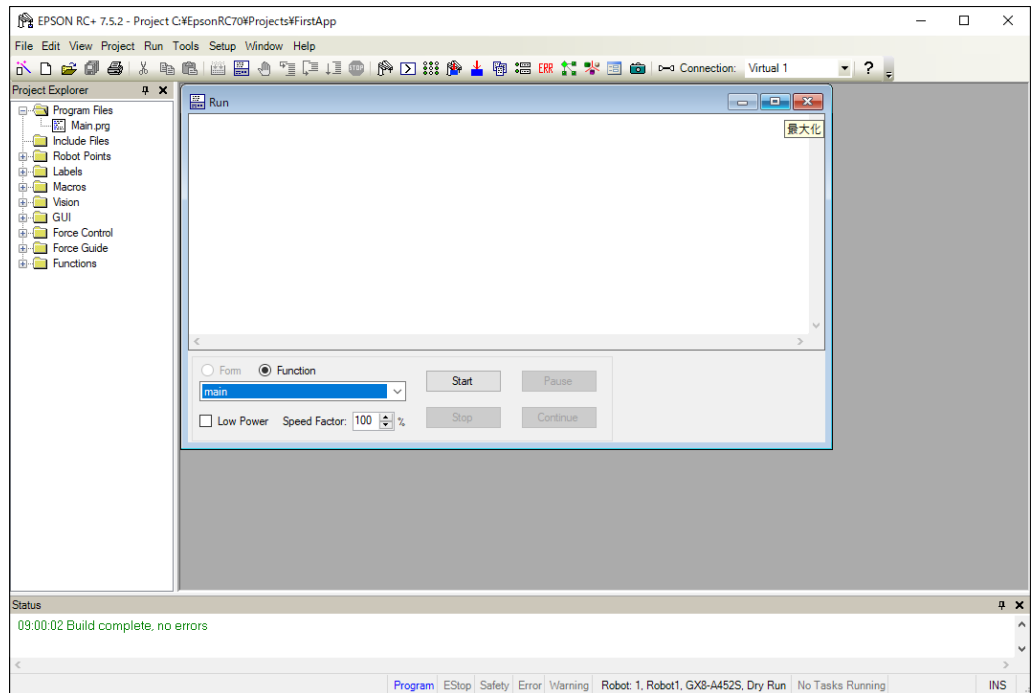

Epson
RC+ 8.0

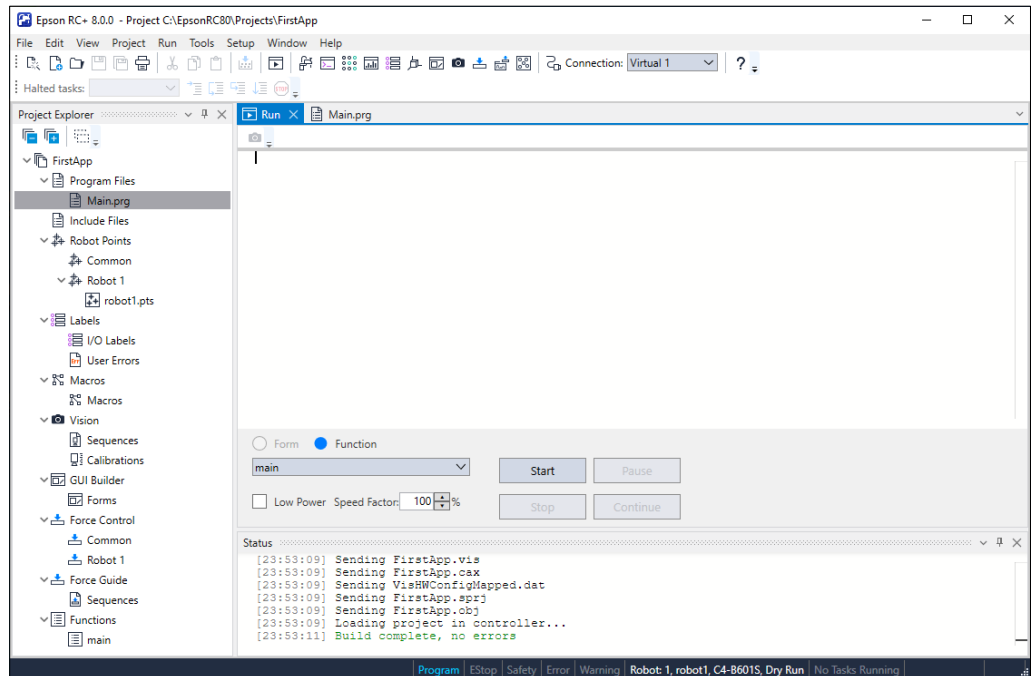

- (3) Click the Start button on the Run window to run the program.

(4) The texts like the following will be displayed in the status window.

Task main started
All tasks stopped

On the Run window, you will see the output of the print statement.

Now let's teach some robot points and modify the program to move the robot.



Teaching described in this procedure should be done outside the safeguard.

5. Teach robot points

(1) Make sure that it is safe to operate the robot. Click the <Robot Manager> button on the toolbar to display the [Robot Manager] window.

(2) Turn ON the motors.

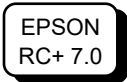

Click the [Control Panel] tab. Then, click the <Motor On> button.

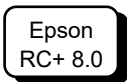
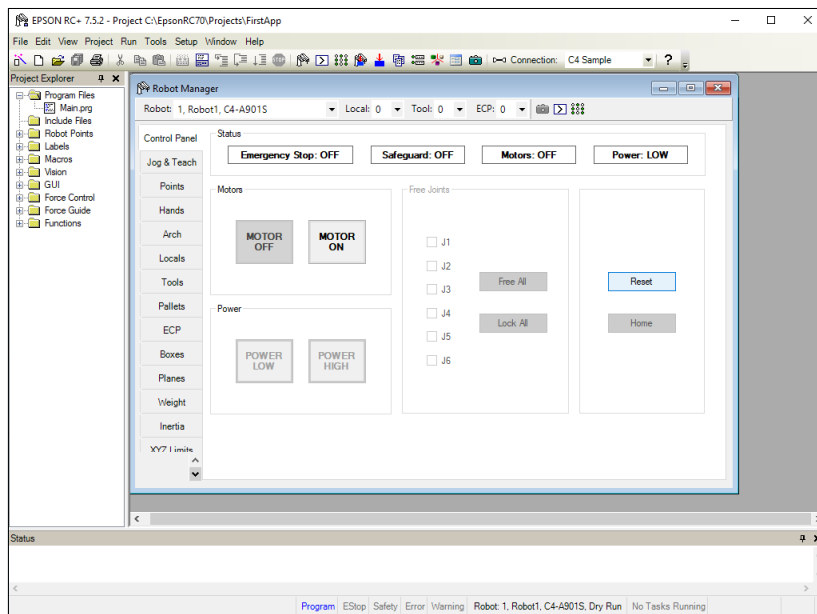

Click the <Motor: Off> button.

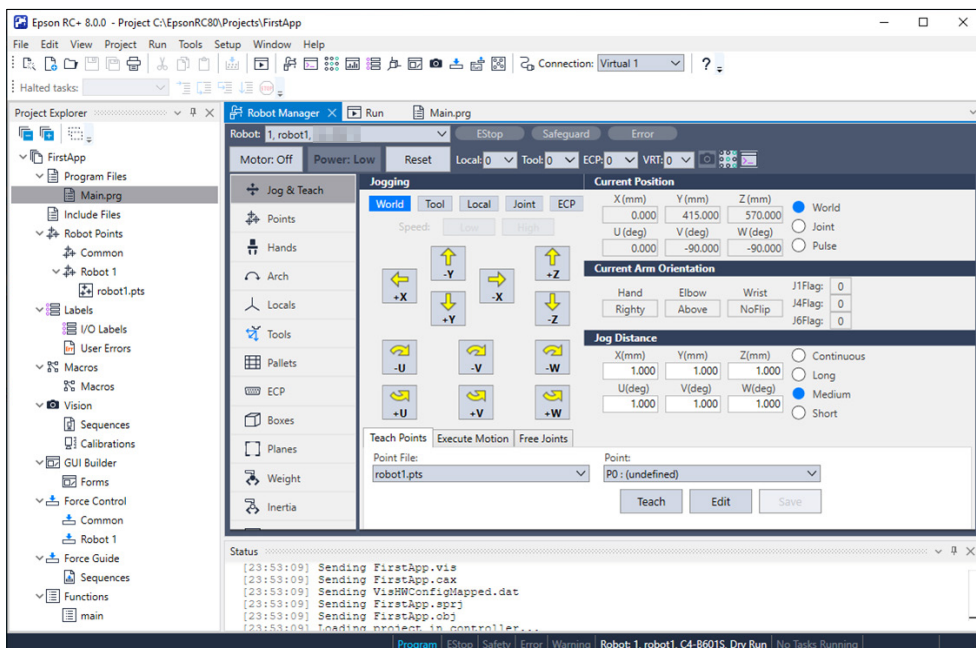

You will be prompted to confirm the operation.

- (3) Click <Yes> to continue.
- (4) Click the [Jog & Teach] tab.

EPSON
RC+ 7.0

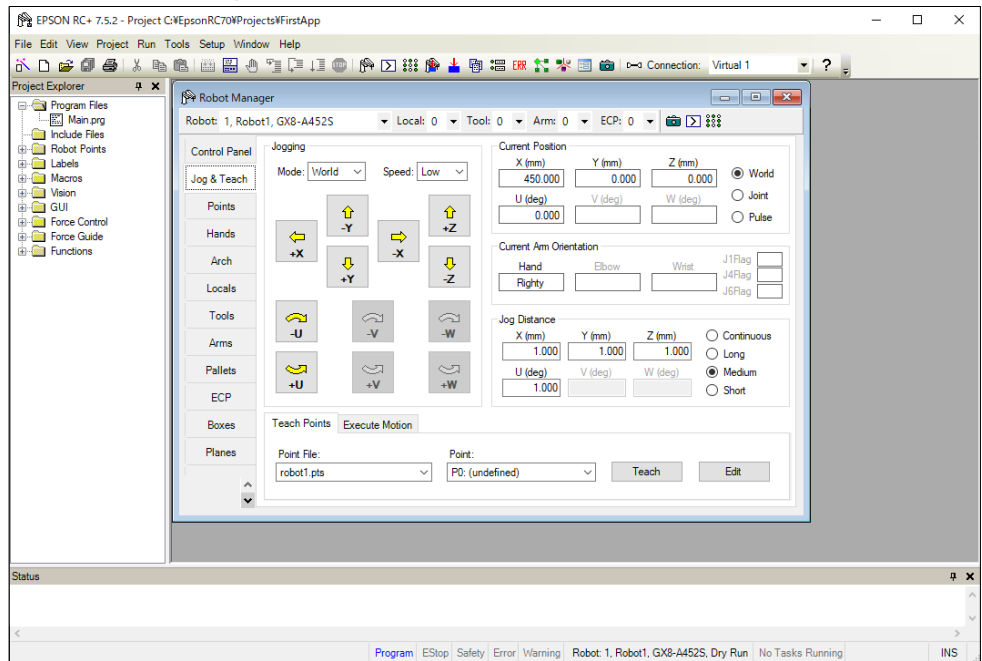

Epson
RC+ 8.0

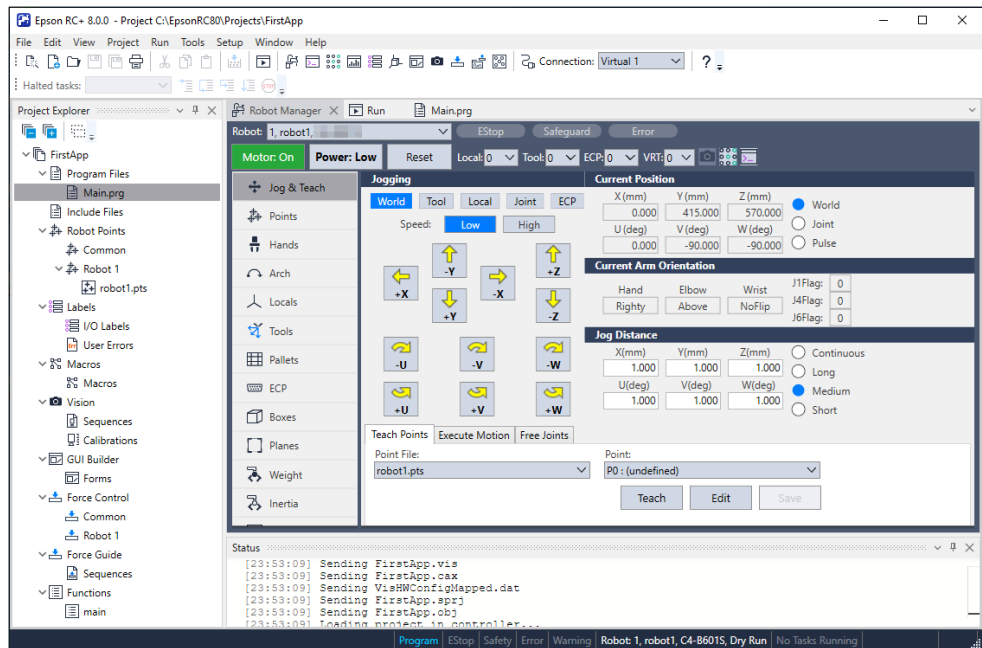

- (5) Click the <Teach> button in the lower right corner to teach point P0. You will be prompted for a point label and description.
- (6) Click the <+Y> jog button to jog the robot in +Y direction. Hold the button down to keep jogging. Move the robot until it reaches the middle of the work envelope.
- (7) Click the <-Z> button to lower the Z axis of the robot.
- (8) Select "P1" in the [Point (P)] dropdown list which is next to the <Teach> button. The current point is set to P1.
- (9) Click the <Teach> button. You will see a confirmation message to teach the point.
- (10) Click the <Yes> button.
- (11) Click the <+X> button to jog the robot in the +X direction.

- (12) Select "P2" in the [Point (P)] dropdown list which is next to the <Teach> button.
The current point is set to P2.
- (13) Click the <Teach> button. You will see a confirmation message to teach the point.
- (14) Click the <Yes> button.
- (15) Click the <Save Project> toolbar button to save the changes.

6. Modify the program to include robot motion commands

- (1) Insert three new Go statements into the Main.prg program as shown below:

```
Function main
  Print "This is my first program."
  Go P1
  Go P2
  Go P0
Fend
```

- (2) Press F5 to display the Run window.
- (3) Click the <Start> button to execute the program.
The robot will move to the points you taught.

7. Modify the program to change speed of robot motion commands

- (1) Insert the Power, Speed, and Accel commands as shown in the program below:

```
Function main
  Print "This is my first program."
  Power High
  Speed 20
  Accel 20, 20
  Go P1
  Go P2
  Go P0
Fend
```

- (2) Press F5 to display the Run window.
- (3) Click the <Start> button to execute the program.
- (4) The robot will move to each of the points you taught at 20% speed, acceleration, and deceleration. The Power High statement executes the program to operate the robot with increased speed and acceleration.

8. Backup the project and system configuration

Even though this is only a sample project, we will backup the project and Controller configuration. Backup can be done easily with Epson RC+. It is important that you keep regular backups of your applications on an external media such as a USB memory key.

Follow the steps below to back up the project and system configuration:

- (1) Select the Epson RC+ menu - [Project] - [Copy].
- (2) Change the [Destination Drive] to an arbitrary drive.
- (3) Click <OK>. The project will be copied to the external media.
- (4) Select the Epson RC+ menu - [Tools] - [Controller].
- (5) Click on the <Backup Controller> button.
- (6) Select the arbitrary drive.
- (7) Click <OK>. The system configuration will be backed up on the external media.

4.4 Firmware Update

This chapter describes the firmware upgrade procedure and data file initialization when firmware or Robot configuration errors cause Controller startup or operation failure.

4.4.1 Updating Firmware

Firmware (software stored in non-volatile memory) and data files necessary to control the Controller and the Robot are preinstalled in the Controller. Controller configuration set from Epson RC+ is always saved in the Controller.

Controller firmware is supplied by CD-ROM as needed. Please contact the supplier of your region for information.

You must use a PC running Epson RC+ connected to a Controller with USB to update the Controller firmware. Firmware cannot be updated with an Ethernet connection.



When installing the firmware Ver.7.5.0.x or later, be sure to use the PC which EPSON RC+ 7.0 Ver.7.5.0 or later is installed.

4.4.2 Firmware Upgrade Procedure

The firmware upgrade procedure is described as follows:

- (1) Connect the development PC and the Controller with a USB cable (the firmware cannot be changed with an Ethernet connection).
- (2) Turn ON the Controller. (Do not start the development software Epson RC+ until the firmware upgrade is completed.)
- (3) Insert the “firmware CD-ROM” in the development PC CD-ROM drive.
- (4) Execute “Ctrlsetup70.exe”. The following dialog appears.
- (5) Select the <Upgrade> option button and click the <Next> button.

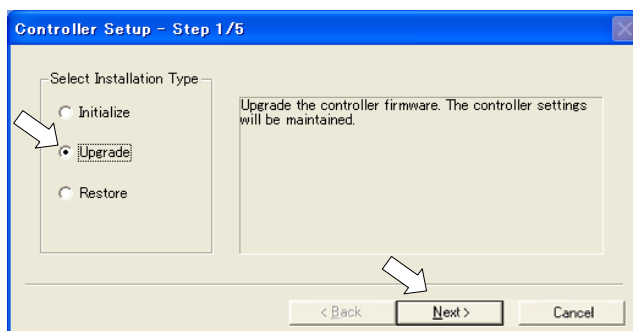

- (6) Make sure that the development PC is connected to the Controller with a USB cable and Click the <Next> button.

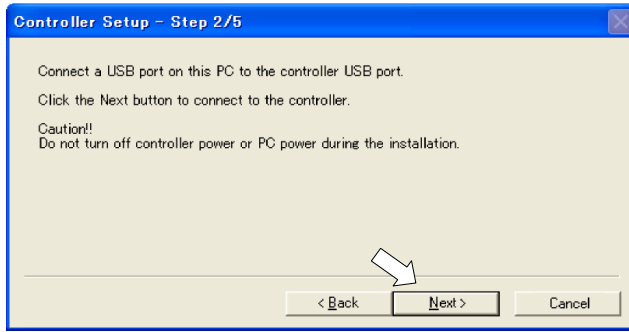

- (7) Check the current firmware version and the new firmware version and click the <Install> button.

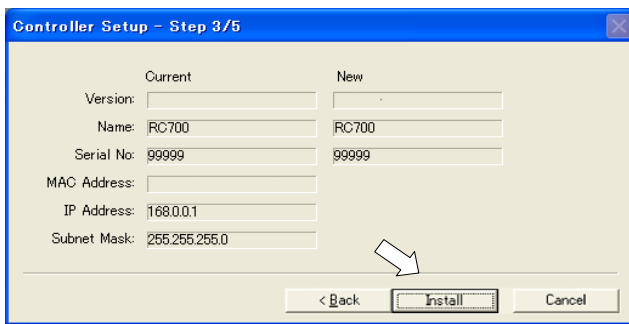

NOTE
☞

- (8) The firmware upgrade starts. It takes several minutes to complete. Do not disconnect the USB cable during transfer or turn OFF the Controller or the development PC.

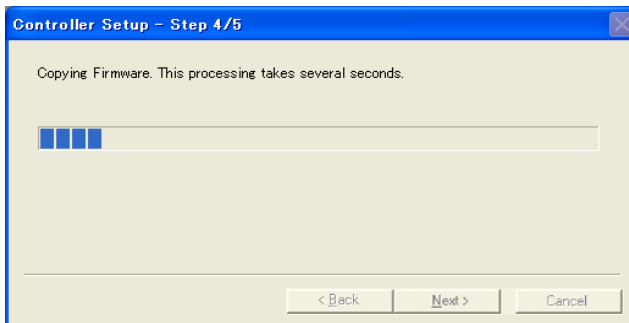

- (9) Continuous data file transfer starts.

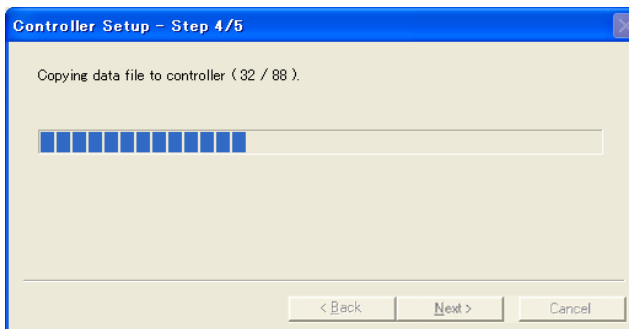

(10) The following dialog appears when transfer has completed. Click the <Next> button to reboot the Controller.

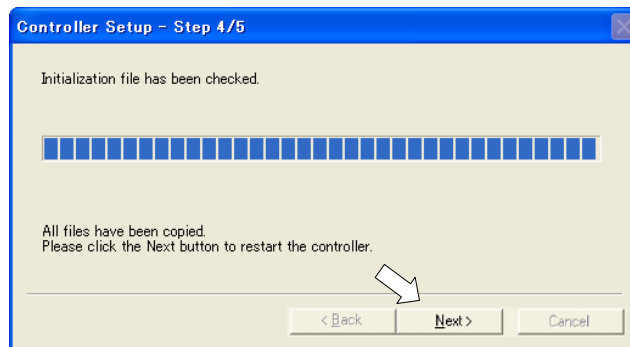

(11) The following dialog appears after the Controller reboot. Click the <Finish> button.

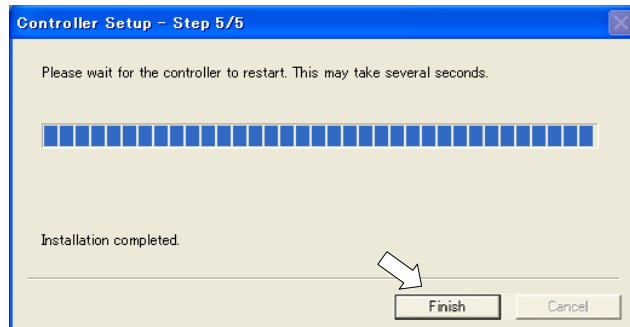

The firmware upgrade is complete.

NOTE

When you install the firmware (Ver.7.4.0.2 or later) on the Controller which the firmware (before Ver.7.4.0.2) has been installed, the following message is displayed.

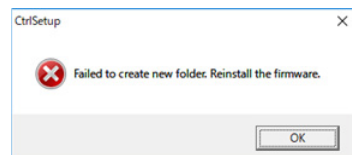

When the message is displayed, re-install the firmware.

4.4.3 Controller Recovery

If the Controller becomes inoperable, use the procedures described in this section to recover.



Controller Backup is recommended for easy recovery of the Controller operation. For details of Controller Backup, refer to *Regular Inspection 2. Backup and Restore*.

The following two conditions describe the Controller error status after turning ON the Controller.

Condition A The Controller automatically changes to Recovery mode and the LED of ERROR, TEACH, and PROGRAM are lighting. You are able to communicate with the development PC though the Controller does not operate properly.

Condition B The LED of TEACH, AUTO, and PROGRAM do not blink.
Cannot communicate with the Controller using the development PC.

Countermeasure for the error status is as follows.

Condition A Follow *4.4.4 Firmware Initialization Procedure* to initialize the firmware.

Condition B Execute the following steps:

- (1) Turn OFF the Controller.
- (2) Push the trigger button located on the front side of the Controller and while holding the button in, turn ON the Controller. Continue to hold in the trigger button for 30 seconds. This will cause the Controller to start in Recovery mode.
- (3) Make sure that the LED of ERROR, TEACH, and PROGRAM are lighting.
- (4) Follow the procedure in *4.4.4 Firmware Initialization Procedure* from step (3) to initialize the firmware.

4.4.4 Firmware Initialization Procedure

The firmware initialization procedure described in this section.

- (1) Connect the development PC to the Controller with a USB cable (the firmware cannot be changed with an Ethernet connection).
- (2) Turn ON the Controller. Do not start the development software Epson RC+ until firmware initialization is complete.
- (3) Insert the “firmware CD-ROM” in the development PC CD-ROM drive.
- (4) Execute “Ctrlsetup.exe”.
- (5) Select the <Initialize> option button and click the <Next> button.

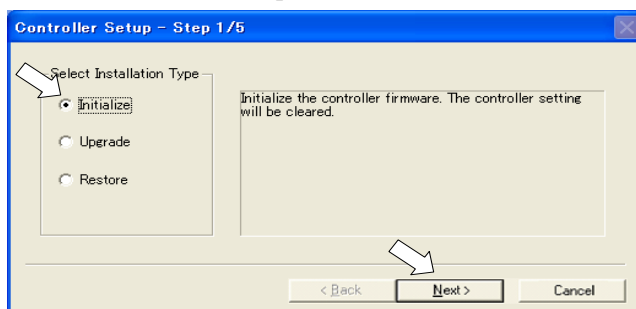

- (6) Make sure that the development PC is connected to the Controller with a USB cable and Click the <Next> button.

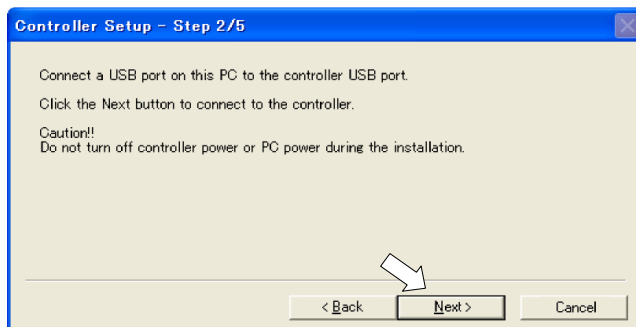

- (7) Check the version information and click the <Install> button.



Firmware and data file transfer starts. It takes several minutes to complete.

NOTE

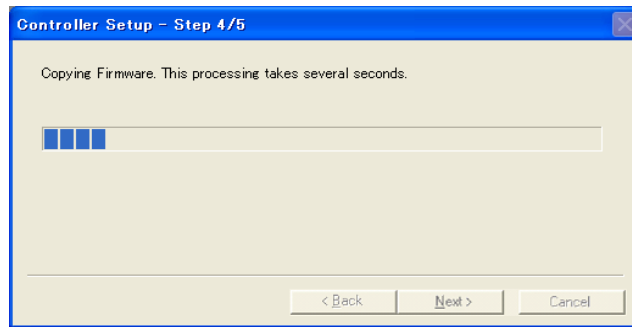

Do not disconnect the USB cable during transfer or turn OFF the Controller or the development PC.

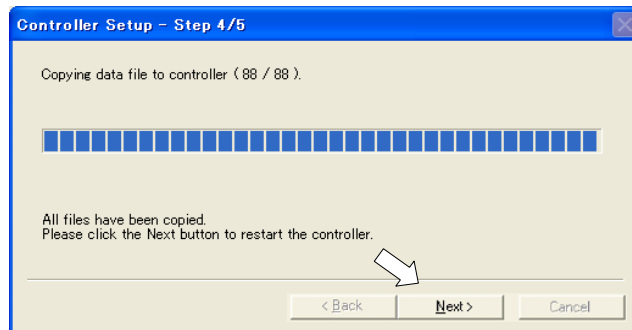

(8) The following dialog appears when transfer is completed. Click the <Next> button to reboot the Controller.

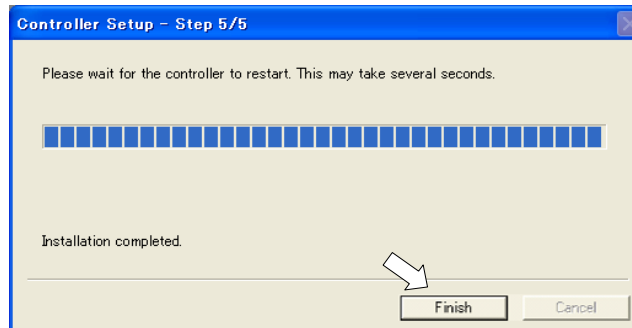

(9) The following dialog appears after the Controller reboot. Click the <Finish> button.



The firmware upgrade is completed.

Start Epson RC+ and restore the Controller settings.

For details of restoring the operating system, refer to *Regular Inspection 2. Backup and Restore*.

NOTE

When you install the firmware (Ver.7.4.0.2 or later) on the Controller which the firmware (before Ver.7.4.0.2) has been installed, the following message is displayed.

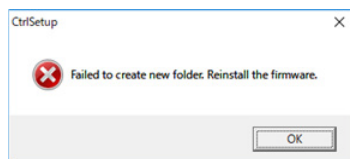

When the message is displayed, re-install the firmware.

4.4.5 Adding Confirmation Steps by Strengthening Security of EtherNet Connection

From the following firmware version password authentication is required when connecting Controllers and PCs to a global accessible network.

F/W : Ver.7.4.8.x

In the following cases, connections of EtherNet (PC) connector and Remote Ethernet are not available.

- Controller IP address is set to global IP address
- Firmware version is 7.4.8.x or later
- EPSON RC+7.0 is Ver.7.4.7 or before

When the Controller firmware is updated under the following conditions, additional steps to confirm whether to continue the firmware update may be execute depending on the configuration settings of the Controller. (step 3 or later shown below)

- Controller IP address is set to global IP address
- Firmware version to be installed is 7.4.8.x or later

The following describes the steps to confirm whether to continue the firmware update.

- (1) Insert “Firmware CD-ROM” to be installed into the CD-ROM driver of the development PC.
- (2) Execute “CtrlSetup70.exe”.
- (3) Controller Setup window is displayed.

Select the <Upgrade> button and click the <Next> button.

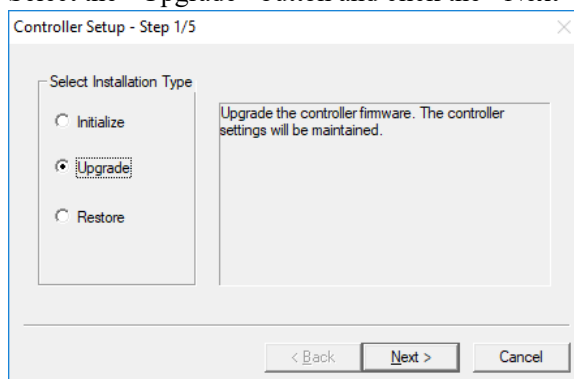

(4) Step 2 window is displayed.

Click the <Next> button.

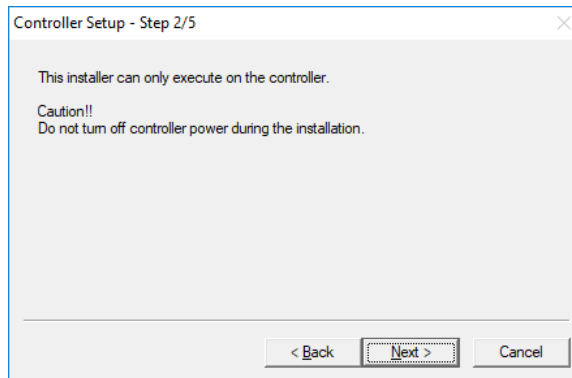

(5) Step 3 window is displayed.

(5)-1 When the steps to confirm whether to continue the firmware update is not executed:

Step 3 window is displayed.

Follow the instructions on the window and install the firmware.

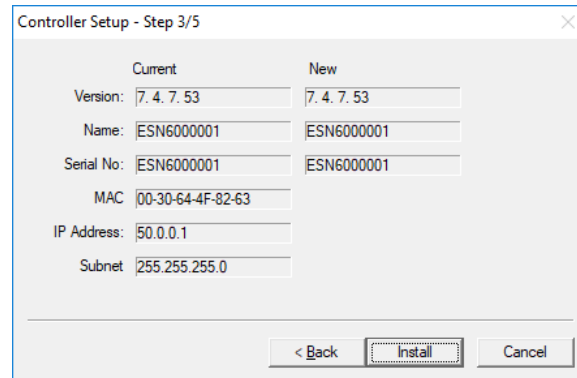

(5)-2 When the steps to confirm whether to continue the firmware update is executed:

The following window is displayed.

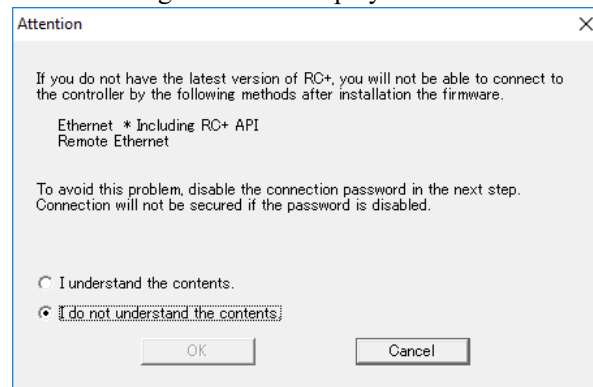

When the <I understand the contents> button is selected, the <OK> button will be enabled.

When the <OK> button is clicked, Step3 window is displayed. Go to the step (6). When the <Cancel> button is clicked, Step3 window is displayed. The [Disable connection password] checkbox and the <Install> button will be grayed out and cannot be selected.

(6) Step 3 window is displayed.

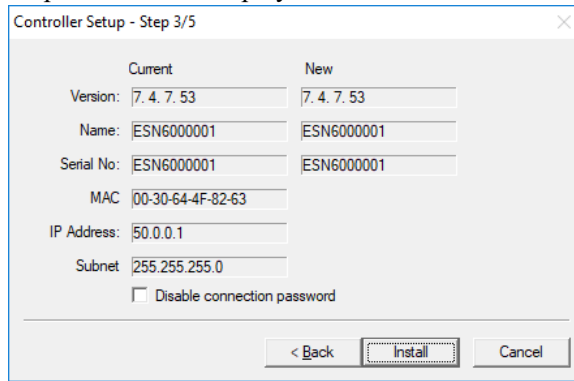

(6)-1 If the [Disable connection password] checkbox is selected, connection authentication after updating the firmware is disabled.

(6)-2 If the <Install> button is clicked, the confirmation window is displayed.

When the [Disable connection password] checkbox is selected:

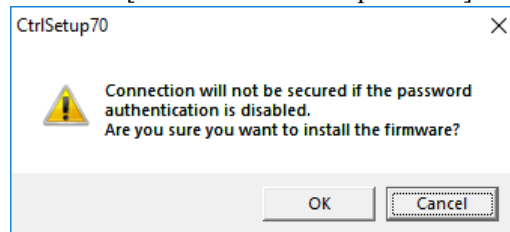

When the [Disable connection password] checkbox is not selected:

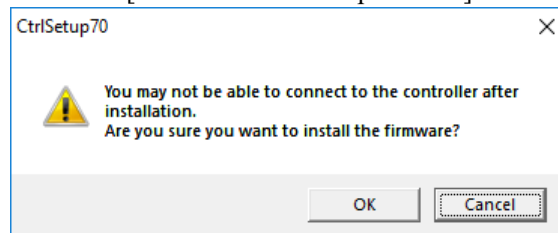

When the <OK> button is clicked, Step 4 window is displayed. Go to the step (7).

When the <Cancel> button is clicked, the window is closed.

(7) Firmware installation starts.

When the firmware is installed, click the <Next> button. Reboot the Controller.

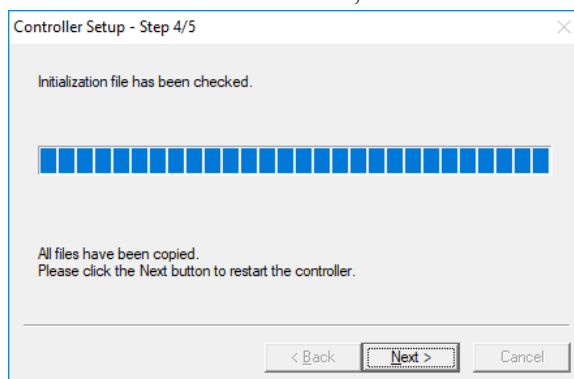

- (8) When the Controller is rebooted, the following window is displayed.
Confirm that the firmware is installed.
Click the <Finish> button.

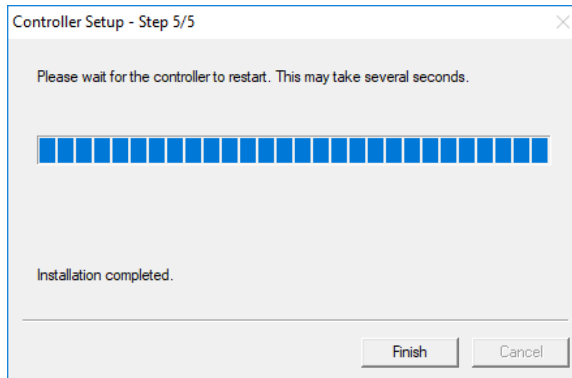

5. Second Step

After operating the robot system as instructed in 4. *First Step*, setup other functions as necessary. This section shows the manuals which contains information of necessary settings and setting procedure.

5.1 Connection with External Equipment

5.1.1 Remote Control

Epson RC+ User's Guide - Remote Control

Functions "12.1 Remote I/O"

I/O

Epson RC+ User's Guide - I/O Setup

Functions "11. I/O Connector" "14.2 Expansion I/O Board"

Fieldbus I/O (Option)

Robot Controller Option Fieldbus I/O Board

5.1.2 Ethernet

Epson RC+ User's Guide

"Security for Controller Ethernet Connection"

"Security for Compact Vision CV2-A Ethernet Connection"

"Security for Feeder Ethernet Connection"

"Ethernet Communication"

Function "7. LAN (Ethernet Communication) Port"

5.1.3 RS-232C (Option)

Epson RC+ User's Guide

"RS-232C Communication"

Function "14.4 RS-232C Board"

5.1.4 Analog I/O board (Option)

Function "14.6 Analog I/O board"

5.1.5 Force Sensor I/F board (Option)

Function "14.7 Force Sensor I/F board"

5.2 Ethernet Connection of Development PC and Controller

Epson RC+ User's Guide

“Security for Controller Ethernet Connection”

“Security for Compact Vision CV2-A Ethernet Connection”

“Security for Feeder Ethernet Connection ”

“Ethernet Communication ”

Function “7. LAN (Ethernet Communication) Port”

5.3 Connection of Teach Pendant (Option)

Function “8. TP Port”

Robot Controller Option Teach Pendant TP2 manual

“Functions & Installation: Installation”

Robot Controller Option Teach Pendant TP3 manual

“Functions & Installation: Installation”

Robot Controller Option Teach Pendant TP4 manual

“Functions & Installation: Installation”

Functions

This section contains information for setup and operation of the Robot Controller.

This chapter is mainly intended for those whose purpose is to know the detailed information of the Robot Controller.

1. Specifications

1.1 System Example

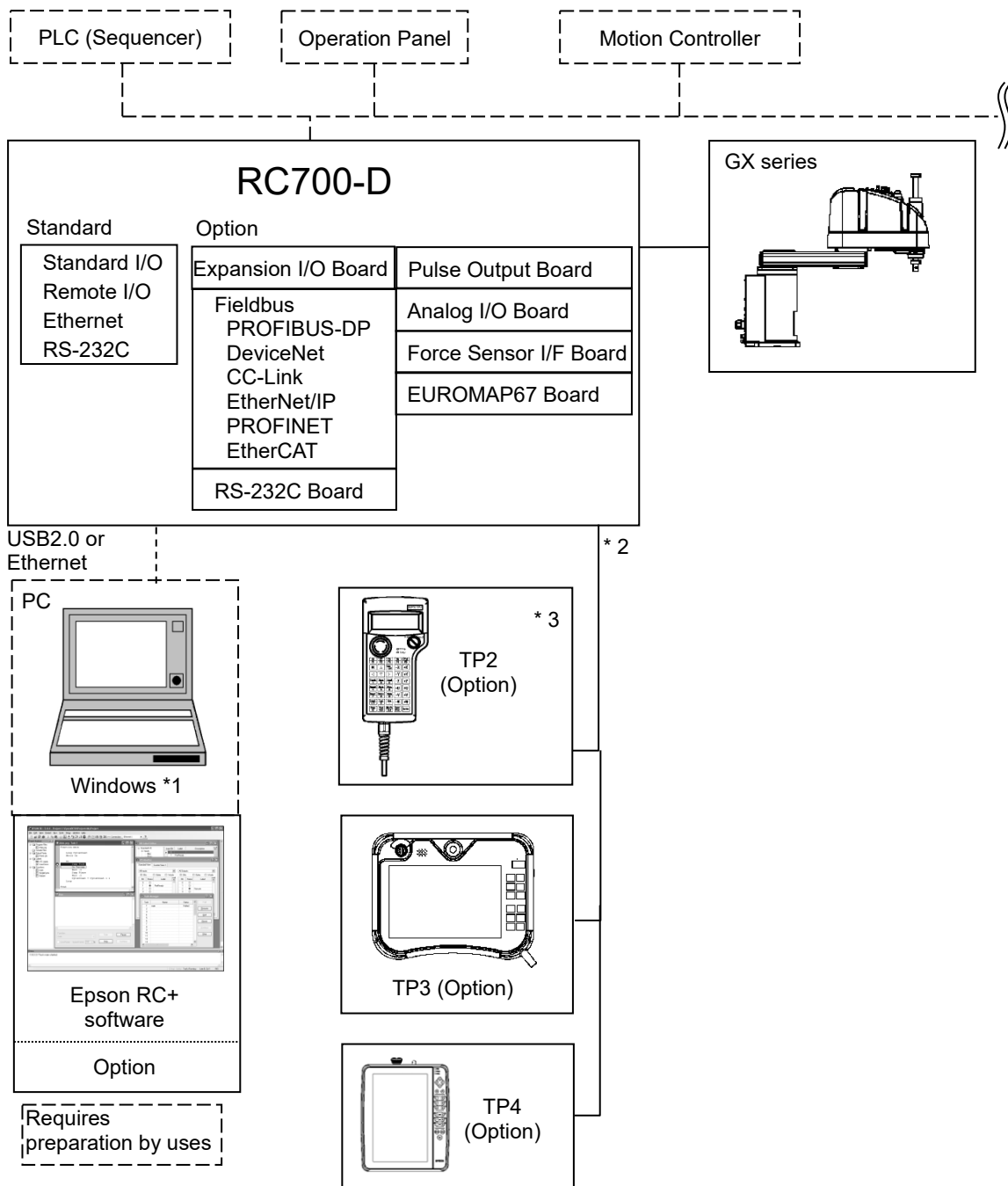

*1 For system requirements, refer to the following manual:
Epson RC+ User's Guide

*2 Any one of the Teach pendant can be controlled.

*3 When connecting to RC700-D, a dedicated conversion cable is required.

1.2 Standard Specifications

Item	Specification		
Model	Robot Controller RC700-D		
CPU	32 bits Micro Processor		
Controllable axes	AC servo motors 4 joints		
Robot Manipulator control	Programming language and Robot control software	Epson RC+ (a multi-tasking robot language)	
	Joint Control	Up to 4 joints simultaneous control Software AC servo control	
	Speed Control	PTP motion : Programmable in the range of 1 to 100% CP motion : Programmable (Actual value to be manually entered.)	
	Acceleration/ deceleration control	PTP motion : Programmable in the range of 1 to 100%; Automatic CP motion : Programmable (Actual value to be manually entered.)	
Positioning control	PTP (Point-To-Point control) CP (Continuous Path control)		
Memory capacity	Maximum Object Size : 4 MB Point data area : 1000 points (per file) Backup variable area : Max. 100 KB (Includes the memory area for the management table.) Approx. 1000 variables (Depends on the size of array variables.)		
External input/output signals (standard)	Standard I/O	Input : 24 Output : 16	Including 8 inputs, 8 outputs with remote function assigned Assignment change allowed
	R-I/O	Input: 2	-
Communication interface (standard)	Ethernet	1 channel	
RS-232C port	1 port		
Options (Max. 4 slots)	Expansion I/O	Input : 24 per board Output : 16 per board	Addition of 4 boards allowed
	Communication interface	RS-232C: 2h per board	Addition of 2 boards allowed *2
		Fieldbus I/O : 1ch per board PROFIBUS-DP DeviceNet CC-Link EtherNet/IP PROFINET EtherCAT	Addition of 1 board from the left allowed
		Force Sensor I/F: 1ch/board	Addition of 1 board allows
	PG	Controllable joints 4 joints/board	Addition of 4 board allows

Item	Specification		
Options (Max. 4 slots)	Analog I/O	SKU1 Output: 1ch	Addition of 4 board from the left allowed
		SKU2 Output: 2ch Input: 2ch	
	EUROMAP67	Input: 15 Output: 16	Addition of 2 boards allowed
Safety features	Emergency stop	The safety function of Emergency Stop Input: Category 3, PLd (reference ISO13849-1: 2015)	
	Safety Door Input (Protection stop)	The safety function of Safety Door Input: Category 3, PLd (reference ISO13849-1: 2015)	
Protection features	<ul style="list-style-type: none"> - Low power mode - Dynamic brake - Motor overload detection - Irregular motor torque (out-of-control Manipulator) detection - Motor speed error detection - Positioning overflow - servo error - detection - Speed overflow - servo error - detection - CPU irregularity detection - Memory check-sum error detection - Overheat detection at the Motor Driver Module - Relay welding detection - Over-voltage detection - AC power supply voltage reduction detection - Temperature error detection - Fan error detection 		
Power Source	200 VAC to 240 VAC Single phase 50/60 Hz		
Maximum Rated Capacity	2.5 kVA (Depending on the Manipulator model)		
Max. load current	12.0A (Depending on the Manipulator model)		
Short-circuit current rating	5 kA		
Maximum Supply Source Impedance	0.32Ω		
Insulation Resistance	100 MΩ or more		
Rated Ambient Temperature	Installation: 5 ~ 40°C Transportation, Storing: - 20 ~ 60°C		
Rated Relative Humidity	Installation: 20 ~ 80 % (with no condensation) Transportation, Storing: 10 ~ 90 % (with no condensation)		
Weight *1	12 kg		
Degree of protection	IP20		

- *1 Weight of the unit is indicated on the Drive Unit and Control Unit itself.
Make sure to check the weight before units transfer or relocation and prevent throwing out your back at holding the unit.
Also, make sure to keep your hands, fingers, and feet safe from being caught or serious injury.
- *2 When using the Force Sensor I/F board, a maximum of one board/two ports expansion is available for RS-232C board.



Use this product under the condition of overvoltage category 2, degree of stain category 2.

1.3 Outer Dimensions

[Unit: mm]

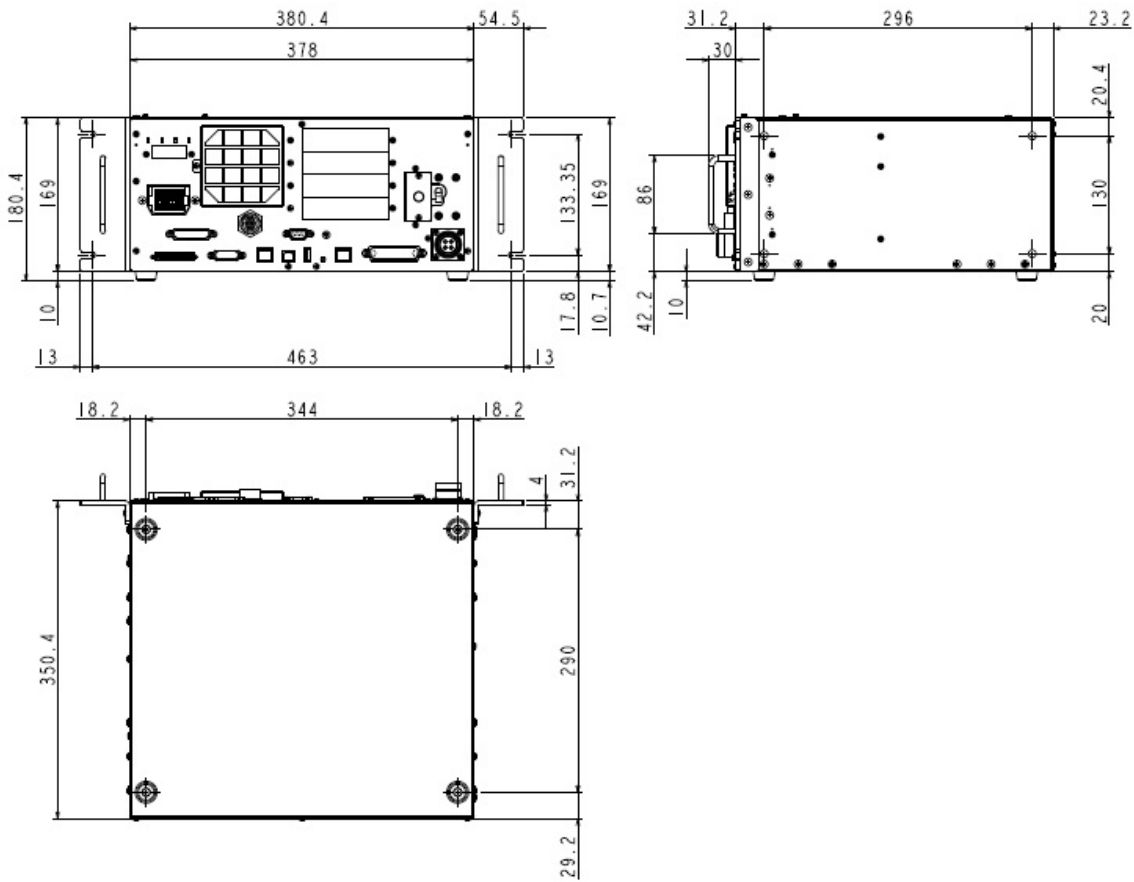

2. Part Names and Functions

RC700-D

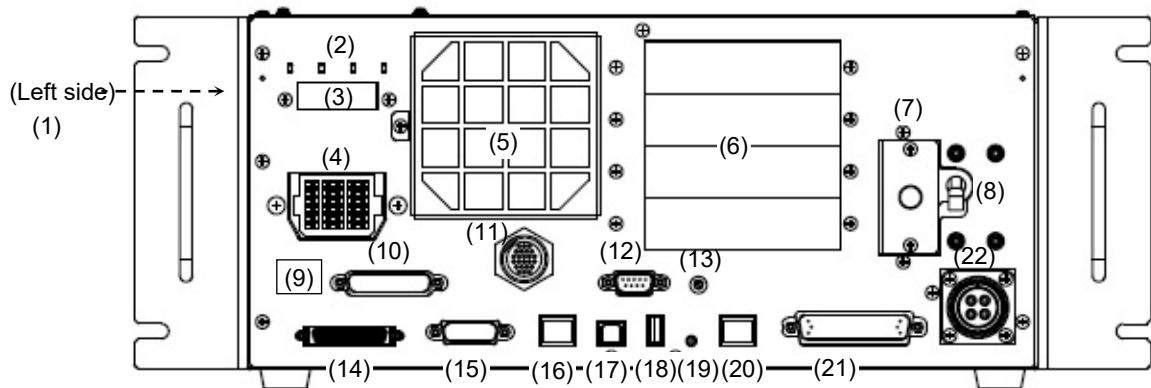

- (1) Signature label (top panel)
The serial number of the Controller and other information are shown.
- (2) LED
The LED indicates current operation mode.
(TEST, TEACH, AUTO, PROGRAM)
For details, refer to *2.1 LED & Seven Segment LED*
- (3) Seven-segment Display
Four-digit seven-segment LED displays the line number and the status of the Controller (error number, warning number, status of Emergency Stop and Safety Door).
For details, refer to *2.1 LED & Seven Segment LED*.
- (4) M/C POWER connector
A connector for the Manipulator power source.
Connect the dedicated power cable attached to the Manipulator.
- (5) Fan Filter
A protective filter is installed in front of the fan to filter out dust.
Check the condition of the filter regularly and clean it when necessary. A dirty filter may result in malfunction of the robot system due to temperature rise of the Drive Unit.
For inspection, cleaning, and replacement, refer to the *Maintenance 4.1 Fan Filter, 4.2 Fan*.
- (6) Option slot
Option boards such as expansion I/O board, Fieldbus I/O board, RS-232C board, PG board, Analog I/O board, and Force Sensor I/F board can be installed. Four slots are available.
For details, refer to *14. Option Slots*.
- (7) Battery
A lithium battery for data backup.
- (8) POWER switch
Turns ON or OFF the Controller.

- (9) **Connection Check label**
The details of the Manipulator to be connected are recorded on the label as shown in the right. The label indicates the Manipulator model and Manipulator serial number.

MANIPULATOR	
GXxxxxx	00001

- (10) **EMERGENCY connector**
This connector is used for input/output from/to Emergency Stop and Safety Door switches. For details, refer to 9. *EMERGENCY*.

- (11) **TP port**
Connects Teach Pendant TP2, TP3, TP4 (Option) and TP bypass plug.
For details, refer to 8. *TP Port*.



Do not connect the following to the TP port of RC700-D. It may result in malfunction of the device since the pin assignments are different.

- OPTIONAL DEVICE dummy plug
- Operation Pendant OP500
- Operator Pendant OP500RC
- Jog Pad JP500
- Teaching Pendant TP-3**
- Operator Panel OP1

- (12) **Standard RS-232C port**
This port is used for the RS-232C communication with external devices.
For details, refer to 10. *Standard RS-232C Port*.

- (13) **Encoder Voltage Adjustment Switch**
Use this switch to adjust voltage according to length of M/C cable. (adjusted as a factory default)
Wrong setting may result in Robot system malfunction.

Switch	M/C Cable Length
1	3 m
2	5 m
3	10 m
4	15, 20 m

- (14) **M/C SIGNAL connector**
This connector is used for signals such as the Manipulator’s motor encoders, etc.
Connect the Manipulator’s dedicated signal cable.

- (15) **R-I/O connector**
This connector is for the input signals used for the real time I/O function.

- (16) **OUT Connector**
The connector for Force Sensor (Optional).

- (17) **Development PC connection USB port**
This port connects the Controller and the Development PC using a USB cable. Do not connect other devices except the Development PC.
For details, refer to 5. *Development PC Connection USB Port*.

- (18) **Memory port**
This port connects the common USB memory for Controller backup function. Do not connect other USB devices except the USB memory.
For details, refer to 6. *Memory Port*.

(19) Trigger Switch

This switch is for Controller backup function using the USB memory.
For details, refer to 6. *Memory Port*.

(20) LAN (Ethernet communication) port

This port connects the Controller and the Development PC using an Ethernet cable.
100BASE-TX / 10BASE-T communication is available.
For details, refer to 7. *LAN (Ethernet communication) Port*.

(21) I/O connector

This connector is used for input/output device. There are 24 inputs and 16 outputs.
For details, refer to Setup & Operation 11. *I/O Connector*.

(22) AC IN

The connector for 200VAC power input.
For details, refer to 3.3.2 *AC Power Cable*.

RC700-D-UL

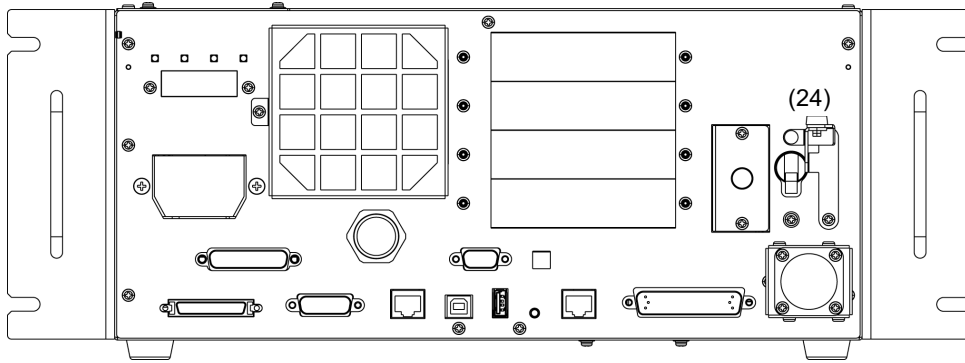

UL-Compliant Controller (RC700-D-UL):

(23) Lock out feature

This feature is used to lock out the power switch when working with the power off such as maintenance.

A padlock for lockout should be prepared by users.

Applicable shackle diameter: 4.0 to 6.5 mm

Perform lockout using the following procedure.

- (1) Remove a fixing screw of lockout bracket A by hand.

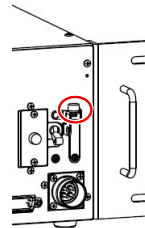

- (2) Rotate the lockout bracket A.

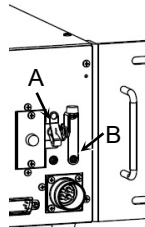

- (3) Set the screw removed in the step (1) to the lockout bracket B so as not to lose it.

- (4) Put a padlock through the holes of the lockout brackets A and B to lock.

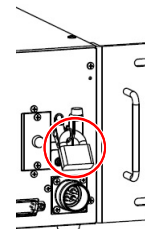

2.1 LED and Seven-segment LED

2.1.1 LED and Seven-segment LED Display

Controller has four LEDs and a four-digit seven-segment LED display.

LED : LED (TEST, TEACH, AUTO, PROGRAM) turns ON according to the current operation mode (TEST, TEACH, Auto, Program).

Seven-segment : Indicates the line number and Controller status (error number, warning number, Emergency Stop or Safeguard status).

From turning ON the Controller to completing startup

LED : All four LEDs blink.

Seven-segment : All four LED digits turn OFF the lights.

After Controller Startup

LED : LED (TEST, TEACH, AUTO, PROGRAM) turns ON according to the current operation mode (TEST, TEACH, Auto, Program).

Seven-segment : Display changes according to the Controller status.

When several Controller statuses occurred at one time, the status indicated earlier on the following table is displayed. For an example, when both Emergency Stop and Safeguard statuses occurred at one time, the display will be as shown below.

Controller status	Display of seven-segment
Execute Controller status storage function to the USB memory	The following two are displayed repeatedly
Complete Controller status storage to USB memory	Displays 00 (for 2 seconds)
Failure of Controller status storage to USB memory	Displays EE (for 2 seconds)
Error	Displays four-digit error number (0.5 sec) and EEEE (0.5 sec) repeatedly. *1
Warning	Displays four-digit warning number (0.5 sec) and HELP (0.5 sec) repeatedly. *1
Emergency Stop	Displays EP Blink
Safety Door	Displays SO Blink
READY	Blink
START	L and line number Blink *2
PAUSE	P and line number Blink *2

*1 For error numbers, refer to *Status Code / Error Code List* or *Online Help*.





*2 In initial status, execution line of task number 1 is displayed in three-digit.

Use Ton statement to change the displayed task number.

For details, refer to *Epson RC+ SPEL+ Language Reference*, or *Online Help*.

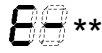
2.1.2 Particular Status Display

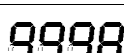
When particular status occurs, seven-segment displays the followings.

Seven-segment	Controller status
	Controller startup failure *1
	Controller startup failure
	Indicate:9999 Controller in Recovery mode Refer to <i>Regular Inspection 2. Backup and Restore.</i>
	Indicate:9998 AC power supply drop is detected and software shut down.
	Indicate:9997 Software shut down is specified from the Epson RC+ (software) or the Teach Pendant (option).

*1 When the Initialize Error occurs, reboot the Controller. If the Initialize Error is displayed again after the Controller is rebooted, please contact the supplier of your region.

2.2 Safety Function

The following safety features which robot system has are particularly important. Make sure that these and other features function properly before operating the robot system.

Emergency Stop Switch

The EMERGENCY connector on the Drive Unit has expansion Emergency Stop input terminals used for connecting the Emergency Stop switches.

Pressing any Emergency Stop switch can shut off the motor power immediately and the robot system will enter the Emergency Stop condition.

Use the emergency switch which has safety function more than PLd.

The safety function of Emergency Stop Input: Category 3, PLd (reference ISO13849-1 2015)

Stop category of Emergency Stop input: Category 1 (reference IEC60204-1 2016)

Safety Door Input

In order to activate this feature, make sure that the Safety Door Input switch is connected to the EMERGENCY connector at the Drive Unit.

When the safety door is opened, normally the Manipulator immediately stops the current operation, and the status of Manipulator power is operation-prohibited until the safety door is closed and the latched condition is released. In order to execute the Manipulator operation while the safety door is open, you must change the mode selector key switch on the Teach Pendant to the “Teach” mode. Manipulator motor can be turned on only when the enable switch is on. In this case, the Manipulator is operated in low power status.

Use the Safety Door Input which has safety function more than PLd.

The safety function of Safety Door Input: Category 3, PLd (reference ISO13849-1 2015)

Stop category of Safety door input: Category 1 (reference IEC60204-1 2016)

Even when using a light curtain as a safety door, keep the operation-prohibited status until the latched condition is released, as with the safety door.

2.3 Protection Features

The robot control system supports protection features described below. However, these features are prepared for unexpected occurrence.

Low Power Mode

The motor power is reduced in this mode.

Executing a power status change instruction will change to the restricted (low power) status regardless of conditions of the safety door or operation mode. The restricted (low power) status ensures the safety of the operator and reduces the possibility of peripheral equipment destruction or damage caused by careless operation.

Dynamic Brake

The dynamic brake circuit includes relays that short the motor armatures. The dynamic brake circuit is activated when there is an Emergency Stop input or when any of the following errors is detected: encoder cable disconnection, motor overload, irregular motor torque, motor speed error, servo error (positioning or speed overflow), irregular CPU, memory check-sum error and overheat condition inside the Motor Driver Module.

Motor Overload Detection

The dynamic brake circuit is activated when the system detects the overload status of the motor.

Irregular Motor Torque (out-of-control Manipulator) Detection

The dynamic brake circuit is activated when irregular motor torque (motor output) is detected.

Motor Speed Error Detection

The dynamic brake circuit is activated when the system detects that the motor is running at incorrect speed.

Positioning Overflow –Servo Error- Detection

The dynamic brake circuit is activated when the system detects that the difference between the Manipulator's actual position and commanded position exceeds the margin of error allowed.

Speed Overflow –Servo Error- Detection

The dynamic brake circuit is activated when the Manipulator's actual speed is detected to mark an overflow (the actual speed is outside the nominal range) error.

CPU Irregularity Detection

Irregularity of CPU that controls the motor is detected by the watchdog timer. The system CPU and the motor controlling CPU inside the Drive Unit are also designed to constantly check each other for any discrepancies. If a discrepancy is detected, the dynamic brake circuit is activated.

Memory Check-sum Error Detection

The dynamic brake circuit is activated when a memory check-sum error is detected.

Overheat Detection at the Motor Driver Module

The dynamic brake circuit is activated when the temperature of the power device inside the Motor Driver module is above the nominal limit.

Relay Deposition Detection

The dynamic brake circuit is activated when relay deposition, junction error, or open fault is detected.

Over-Voltage Detection

The dynamic brake circuit is activated when the voltage of the Drive Unit is above the normal limit.

AC Power Supply Voltage Drop Detection

The dynamic brake circuit is activated when the drop of the power supply voltage is detected.

Temperature Anomaly Detection

The temperature anomaly is detected.

Fan Malfunction Detection

Malfunction of the fan rotation speed is detected.

3. Installation

3.1 Unpacking

TP/OP Bypass Plug	1 unit
EMERGENCY Port Connector	1 set
I/O Connector	1 set
Rack-Mount Plate	1 set
Power Cable	1 cable
USB Cable Clamp	1 set

3.2 Environmental Requirements

 WARNING	<ul style="list-style-type: none"> Do not disassemble the parts not described in the manual or perform maintenance in a method different from the description. Incorrect disassembly and maintenance can cause the robot system not only to malfunction, but also to cause serious safety problems.
--	--

 WARNING	<ul style="list-style-type: none"> The Manipulator and the Controller must be used within the environmental conditions described in their manuals. This product has been designed and manufactured strictly for use in a normal indoor environment. Using the product in the environment that exceeds the conditions may not only shorten the life cycle of the product but also cause serious safety problems.
---	--

3.2.1 Environment

In order to optimize the robot system’s performance for safety, the Controller must be placed in an environment that satisfies the following conditions:



- The Controller is not designed for clean-room specification. If it must be installed in a clean room, be sure to install it in a proper enclosure with adequate ventilation and cooling.
- Install Controller in a location that allows easy connection / disconnection of cables.
- Install the controller outside of the safeguard.
- If there are conductive things such as fences or ladders within 2.5 m of the Controller, ground the things.

Item	Condition
Ambient temperature	5~40 °C
Ambient relative humidity	20% to 80% (with no condensation)
Fast transient burst noise	2 kV or less (Power supply wire) 1 kV or less (Signal wire)
Electrostatic noise	4 kV or less
Base table	Use a base table that is at least 100 mm off the floor. Placing the Controller directly on the floor could allow dust penetration leading to malfunction.
Install surface	Tilt 0.5° or less (When installing upright, you put your hand on it, it may fall over.)
Altitude	2000 m or less

If the Controller must be used in an environment that does not fulfill the conditions mentioned above, take adequate countermeasures. For example, the Controller may be enclosed in a cabinet with adequate ventilation and cooling.

- Install indoors only.
- Place in a well-ventilated area.
- Keep away from direct sunlight and radiation heat.
- Keep away from dust, oily mist, oil, salinity, metal powder or other contaminants.
- Keep away from water.
- Keep away from shocks or vibrations.
- Keep away from sources of electronic noise
- Keep away from strong electric or magnetic fields.

3.2.2 Installation

Install the Controller on a flat surface such as wall, floor, and Controller box in the direction shown from (A) to (C).

(A) Flat Mounting

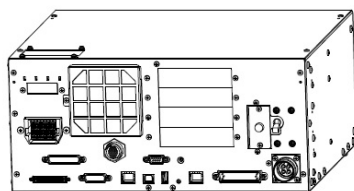

(B) Upright Mounting

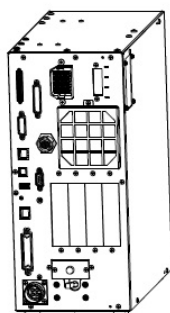

(C) Rack Mounting

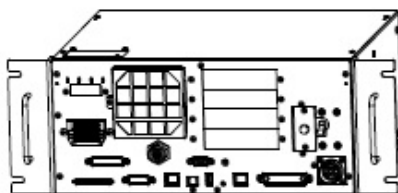

* The rubber foot needs to be replaced. Attach the rubber foot with the flat side facing the controller. Remove the screws that interfere the rubber foot. The size of the screw that secure the rubber foot is M4×8. When replacing the rubber foot, be careful not to lose the screw. Also, do not use a screw of size other than M4×8.

* A plate for rack mounting is required.



For Controller installation to the Controller box or the base table, process screw holes as follows.

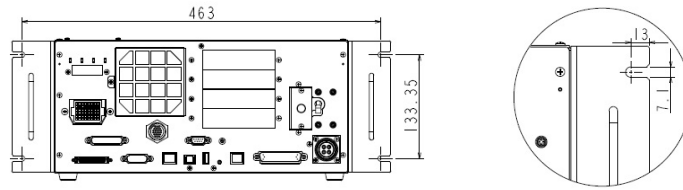

- Ensure the air flow around the supply and exhaust ports, and install the Controller while leaving space from other equipment or walls as below.
 - * Keep the space about 200 mm or more on the top to maintenance.

(A) Flat mounting, (C) Rack mounting

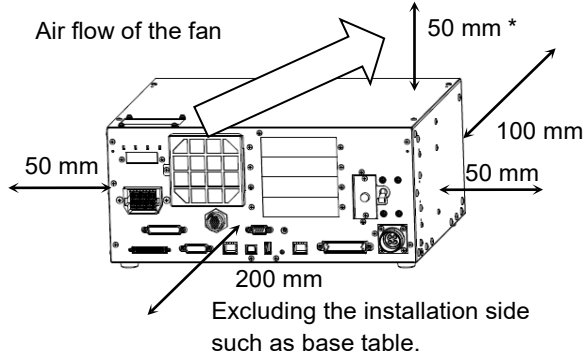

(Figure Flat mounting)

(B) Upright mounting

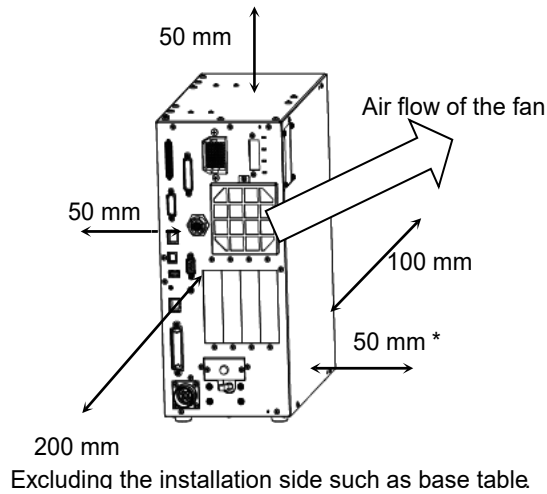

- Hot air with higher temperature than the ambient temperature (about 10 °C) comes out from the Controller. Make sure that heat sensitive devices are not placed near the outlet.
- Arrange the cables in front of the Controller so that you can pull the Controller forward.

3.2.3 Wall Mounting Option

The controller has a wall mounting option. For more information, please contact the supplier of your region.

Controller outer dimensions when using the wall mounting option

Dimensions of the mounting holes for the wall

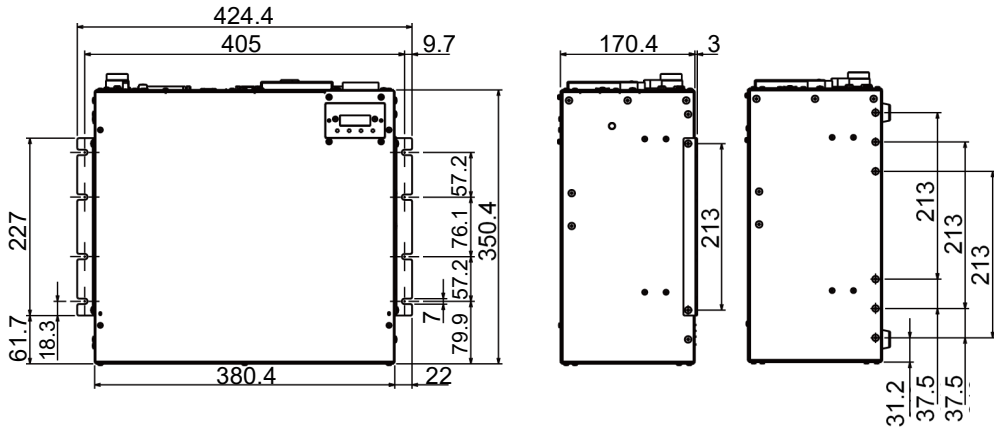

(Unit: mm)

Ensure the air flow around the supply and exhaust ports, and install the Controller while leaving space from other equipment or walls as below.

* Keep the space about 200 mm or more on the top to maintenance.

Wall mounting with the front side down

Wall mounting with the front side up

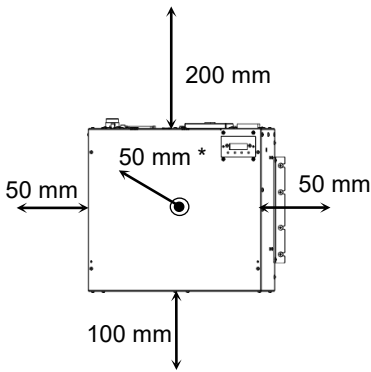
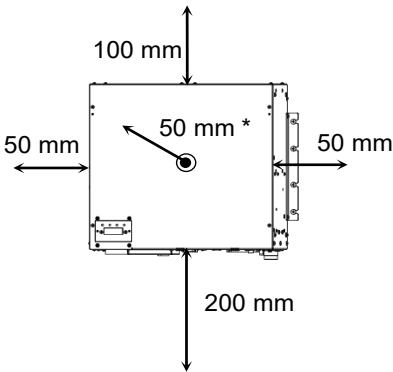

3.3 Power Supply

3.3.1 Specifications

Ensure that the available power meets following specifications.

Item	Specification
Voltage	200 to 240 VAC (Input voltage should be within $\pm 10\%$ of the rated voltage.)
Phase	Single phase
Frequency	50/60 Hz
Momentary Power Interrupt	10 ms or less
Rated Capacity	Maximum: 2.5 kVA Actual power consumption depends on the model, motion, and load of the Manipulator. For approximate power consumption of each model, refer to the following values. GX4: 1.2 kVA GX8: 2.2 kVA Refer to the Manipulator manual for rated capacity of the Manipulator motor.
Max. load current	Max : 12.0 A Actual Value depends on the model, motion, and load of the Manipulator. For approximate power consumption of each model, refer to the following values. GX4: 6.0 A GX8: 12.0 A
Short-circuit current rating	5 kA
Maximum Supply Source Impedance	0.32 Ω
Inrush Current	When power is turned ON : approximately 85 A (2 ms.) When motor is ON : approximately 75 A (2 ms.)
Leakage Current	Less than 3.5 mA
Ground Resistance	TN Ground (100 Ω or less)

Install an earth leakage circuit breaker in the AC power cable line at 15 A or less rated. Both should be a two-pole disconnect type. If you install an earth leakage circuit breaker, make sure to use an inverter type that does not operate by induction of a 10 kHz or more leakage current. If you install a circuit breaker, please select one that will handle the above mentioned “inrush current”.

The power receptacle shall be installed near the equipment and shall be easily accessible.

3.3.2 AC Power Cable

 WARNING	<ul style="list-style-type: none"> ■ Make sure that operations are done by a qualified personal. ■ Be sure to connect the earth wire (green/yellow) of the AC power cable to the earth terminal of the factory power supply. The equipment must be grounded properly at all times to avoid the risk of electric shock. ■ Always use a power plug or a disconnecting device for power connecting cable. Never connect the Controller directly to the factory power supply. ■ Select the plug or a disconnecting device which conform safety standards for nations.
--	---

When connecting the plug of the AC power cable to the Controller, insert until it clicks as shown in the figure below.





Following shows specification of power connection side. Mount to the plug like following below.

Item	Specification
AC power wire (2 cables)	Black, Black
Ground wire	Green / Yellow
Cable length	3 m
Terminal	M4 round solderless terminal



3.4 Cable Connection

 <p>WARNING</p>	<ul style="list-style-type: none">■ Make sure that the power to the Controller is turned OFF and the power plug is disconnected before connecting or disconnecting any cables. Connecting or disconnecting any cables with the power ON is extremely hazardous and may result in electric shock and malfunction of the Controller.■ Be sure to connect the cables properly. Protect it with the strong cable cover and do not allow unnecessary strain on the cables. (Do not put heavy objects on the cables. Do not bend or pull the cables forcibly.) The unnecessary strain on the cables may result in damage to the cables, disconnection, and/or contact failure. Damaged cables, disconnection, or contact failure is extremely hazardous and may result in electric shock and/or improper function of the system.
--	---

 <p>CAUTION</p>	<ul style="list-style-type: none">■ The serial number of the Manipulator that should be connected is indicated on the Connection Check Label on the Controller. Connect the Controller and the Manipulator correctly. Improper connection between the Controller and the Manipulator may cause not only improper function of the robot system but also safety problems.■ Before connecting the connector, make sure that the pins are not bent. Connecting with the pins bent may damage the connector and result in malfunction of the robot system.
--	--

3.4.1 Typical Cable Connection

Example for Control Unit

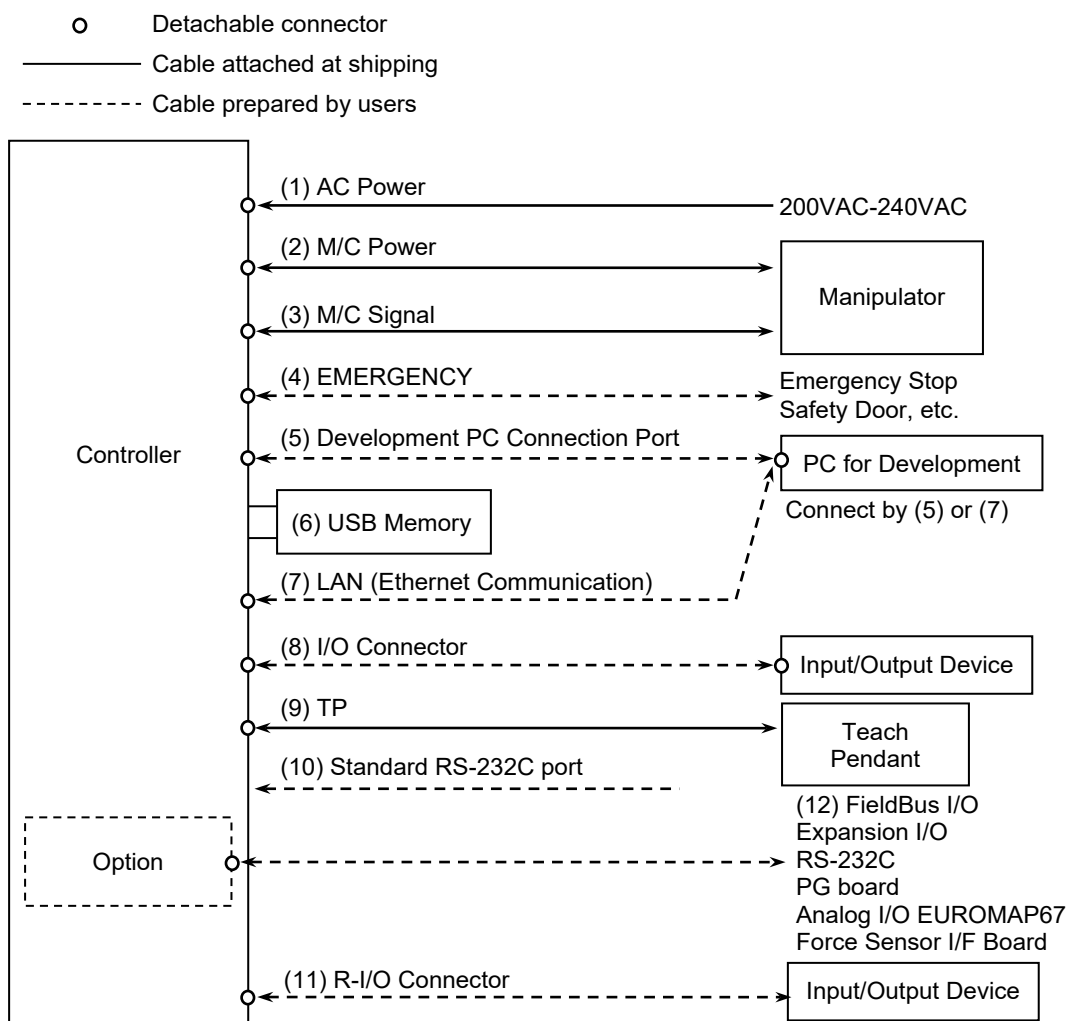



- (1) AC Power
Connector for 200VAC power input to the Controller.
- (2) M/C Power
The cable with connector on the Controller side.
Connect the Manipulator and the M/C POWER connector on the Controller.
Insert the connectors until you hear a “click”.
- (3) M/C Signal
The cable with connector on the Controller side.
Connect the Manipulator and the M/C SIGNAL connector on the Controller.
- (4) EMERGENCY
The EMERGENCY connector has inputs to connect the Emergency Stop switch and the Safety Door switch. For safety reasons, connect proper switches for these input devices.
For details, refer to the 9. EMERGENCY.

- (5) PC for development
Connect the PC for development.
For details, refer to the 5. *Development PC Connection USB Port*.
- (6) USB memory
Connect the USB memory.
For details, refer to the 6. *Memory Port*.
- (7) LAN (EtherNet Communication)
Connect the EtherNet cable.
For details, refer to the 7. *LAN (Ethernet Communication) Port*.
- (8) I/O connector
This connector is used for input/output devices of the user.
When there are input/output devices, use this connector.
There are I/O cable (option) and terminal block (option) for the I/O connector.
For details, refer to the 11. *I/O Connector*.
- (9) TP
Connect the option Teach Pendant.
For details, refer to the 8. *TP Port*.
- (10) Standard RS-232C port
This port is used for the RS-232C communication with external devices.
For details, refer to 10. *Standard RS-232C Port*.
- (11) R-I/O Connector
This connector is used for connecting with input signals necessary for real time I/O function.
For details, refer to the 13. *R-I/O Connector*.
- (12) Fieldbus I/O
If necessary, take EMC countermeasures for the Fieldbus I/O cable.
For details, refer to 3.5 *Noise Countermeasures*.

3.4.2 Connecting Manipulator to Controller

Connect the Manipulator to the Controller by using the Power cable and the Signal cable.

 WARNING	<ul style="list-style-type: none"> ■ Make sure that the power to the Controller is turned OFF before connecting or disconnecting any cables. Connecting or disconnecting any cables with the power ON is extremely hazardous and may result in electric shock and malfunction of the Controller. ■ Be sure to connect the cables properly. Protect it with the strong cable cover and do not allow unnecessary strain on the cables. (Do not put heavy objects on the cables. Do not bend or pull the cables forcibly.) The unnecessary strain on the cables may result in damage to the cables, disconnection, and/or contact failure. Damaged cables, disconnection, or contact failure is extremely hazardous and may result in electric shock and/or improper function of the system.
 CAUTION	<ul style="list-style-type: none"> ■ The serial number of the Manipulator that should be connected is indicated on the Connection Check Label on the Controller. Connect the Controller and the Manipulator correctly. Improper connection between the Controller and the Manipulator may cause not only improper function of the robot system but also safety problems. ■ When connecting the Manipulator to the Controller, make sure that the serial numbers on each equipment match. Improper connection between the Manipulator and Controller may not only cause improper function of the robot system but also serious safety problems. The connection method varies with the Controller used.

The configuration data for the Manipulator and Manipulator model are stored in the Controller. Therefore, the Controller should be connected to the Manipulator whose serial number is specified in the Connection Check label attached on the front of the Controller.



The Manipulator's serial number is indicated on the signature label on the back of the Manipulator.

3.5 Noise Countermeasures

To minimize electrical noise conditions, the following items must be observed in the system's cable wiring:

To minimize electrical noise condition, be sure of followings for wiring.

- The earth wire of the power supply should be grounded. (Ground resistance: 100 Ω or less) It is important to ground the frame of Controller not only for prevention from electric shock, but also for reducing the influence of electric noise around the Controller. Therefore, be sure to connect the earth wire (yellow/green) of the Controller's power cable to the ground terminal of the factory power supply. For details about the plug and AC power cable, refer to the 3.3 *Power Supply*.
- Do not tap power from a power line that connects to any equipment which may cause noise.
- When you tap power for the Controller and the single-phase AC motor from the same power line, change the phase of one or the other. Ensure that they will not be the same phase.
- Use a twisted pair motor power line.
- Do not run AC power lines and DC power lines in the same wiring duct, and separate them as far as possible. For example, separate the AC motor power line and the Controller power line as far as possible from the sensor or valve I/O lines; and do not bundle both sets of wiring with the same cable tie. If more than one duct/cable must cross each other, they should cross perpendicularly. The preferable example is shown in the right figure.

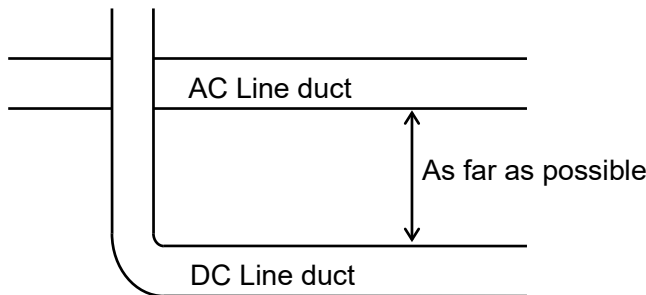

- Wire as short as possible to the I/O connector and EMERGENCY connector. Use a shielded cable and clamp the shield to the attached connector interior. Make sure to keep away from the peripheral noise source as far as possible.
- Make sure that the induction elements used to connect to the Controller's I/O (such as relays and solenoid valves) are noise suppression parts. If an induction element without protection against noise is used, make sure to connect a noise suppression part such as a diode located at the induction element in parallel with it. In selecting noise suppression parts, make sure that they can handle the voltage and current incurred by the induction load.
- To start and change revolutions of the conveyer's (or the like's) AC motor (ex: an induction motor or three-phase induction motor) regularly or abruptly, make sure to install a spark suppressor between the wires. The spark suppressor is more effective when placed closer to the motor.
- As they are easily influenced by noise, keep cable such as USB, Ethernet, RS-232C, or fieldbus away from peripheral noise sources.

- Perform following EMC countermeasure for the Fieldbus I/O cable as necessary.
- Put together the cable shield side.

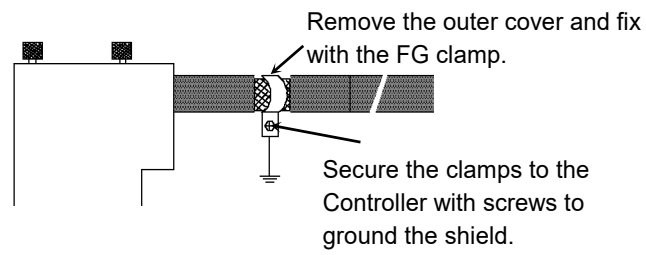

- Mount Ferrite core to the cable.

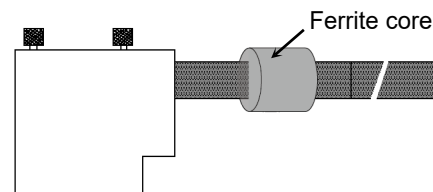

4. Operation Mode (TEACH/AUTO/TEST)

4.1 Overview

The Robot system has three operation modes.

 WARNING	<ul style="list-style-type: none"> ■ When operate teaching, place people to check operation outside the safeguard so that the manipulator can be stopped immediately in the event of an anomaly. Before teaching, check that there is no danger such as there is a person in the safeguard.
---	--

TEACH mode This mode enables point data teaching and checking close to the Robot using the Teach Pendant.
In this mode the Robot operates in Low power status.

AUTO mode This mode enables automatic operation (program execution) of the Robot system for the manufacturing operation, and also programming, debug, adjustment, and maintenance of the Robot system.
This mode cannot operate the Robots or run programs with the Safety Door open.

TEST mode

(T1) This mode enables program verification while the Enable Switch is held down and the safeguard is open.
This is a low speed program verification function (T1: manual deceleration mode) which is defined in Safety Standards.
In this mode, the specified Function can be executed with multi-task / single-task at low speed.

(T2) This mode enables program verification while the Enable Switch is held down and the safeguard (including the safety door) is open.
Unlike the TEST/T1, the program verification in a high speed is available in this mode.
In this mode, the specified Function can be executed with multi-task / single-task at high speed.

NOTE  T2 mode cannot be used on RC700-D Controllers complying with the UL standards.

NOTE  To use a low speed program verification function (T1: manual deceleration mode) or a high speed program verification function (T2: manual deceleration mode) which is defined in Safety Standards, you will need a Teach Pendant that supported for the function.

4.2 Switch Operation Mode

 WARNING	<ul style="list-style-type: none"> ■ Change the operation mode using the mode selector key switch on the Teach Pendant. When changing operation mode, operate it outside the safeguard to avoid danger.
--	--

To change to TEST operation mode: (TP3, TP4):

Tap the [Test] tab on the touch panel in TEACH mode.

TEACH mode Turn the mode selector key switch to “TEACH” for TEACH mode. Pauses the executing program when operation mode is switched to TEACH mode.

The operating Robot stops by Quick Pause.

AUTO mode Turn the mode selector key switch to “AUTO” and change the latch release input signal to ON position for AUTO mode.

TEST mode

TP3 or TP4 T1 Turn the mode selector key switch to “TEACH/T1” for “TEACH” mode. Tap the [Test] tab to change the mode to T1.

TP3 or TP4 T2 Turn the mode selector key switch to “TEACH/T2” for “TEACH” mode. Tap the [Test(T2)] tab to change the mode to T2.

 WARNING	<ul style="list-style-type: none"> ■ If you switch the mode from TEACH to AUTO, Teach Pendant displays “Workers must leave the safeguard area” message. Please ensure safety when working.
--	---



The TEACH mode status is latched by software.

To switch the mode from TEACH to AUTO, release the latched condition using the latch release input.

For details on how to release latch, refer to *9.1 Safety Door Switch and Latch Release Switch*.



T2 mode cannot be used on RC700-D Controllers complying with the UL standards.



When switching the mode by mode selector key switch, the motor turns off.



When switching the mode by mode selector key switch, turn off the Enable Switch.

If you switch the mode with the mode selector key switch and turn on the motor while the enable switch is ON, an error will occur. Turn the Enable Switch off and then on again, and then turn on the motor.

4.3 Program Mode (AUTO)

4.3.1 What is Program Mode (AUTO)?

Program mode is for programming, debug, adjustment, and maintenance of the Robot system.

Follow the procedures below to switch to the Program mode.

4.3.2 Setup from Epson RC+

Switch the mode to Program mode from the Epson RC+.

- (1) Select Epson RC+ menu-[Setup]-[System Configuration] to display the [System Configuration] dialog.

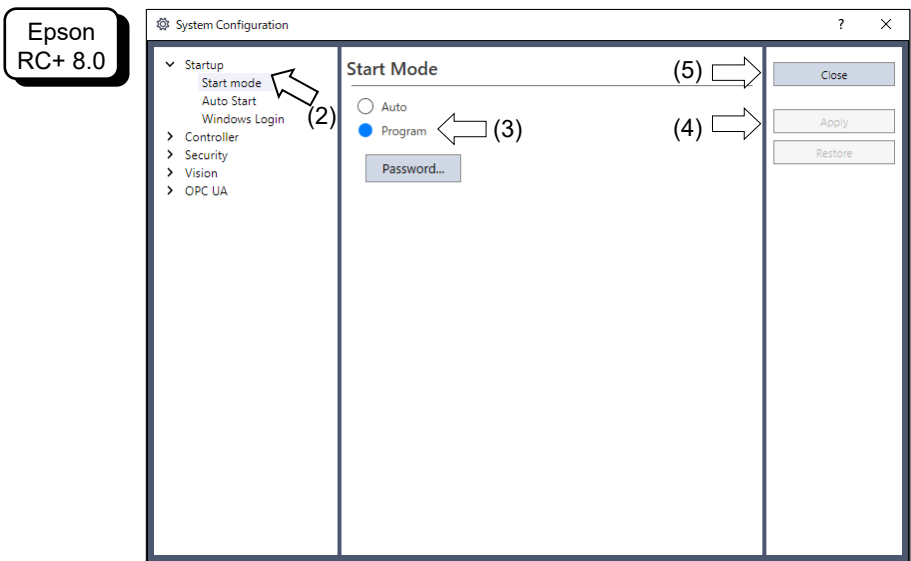
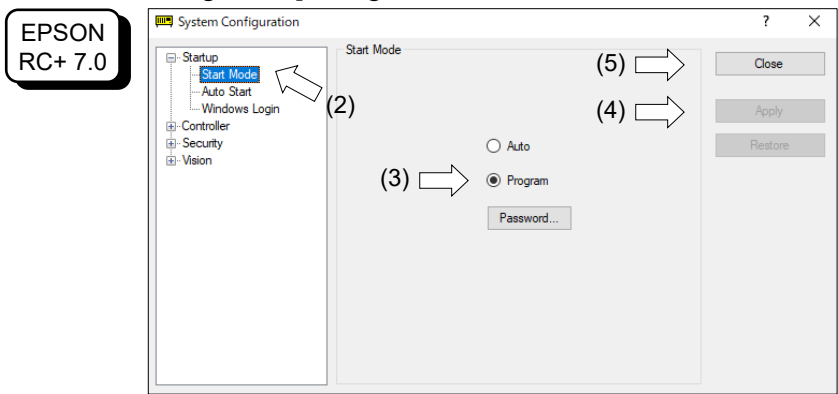

- (2) Select [Startup]-[Start mode].
- (3) Select <Program> button.
- (4) Click the <Apply> button.
- (5) Click the <Close> button.

4.4 Auto Mode (AUTO)

4.4.1 What is Auto mode (AUTO)?

Auto mode (AUTO) is for automatic operation of the Robot system.

Procedures for switching to the Auto mode (AUTO) are the followings.

A : Set the start mode of the Epson RC+ to “Auto” and start the Epson RC+.

(Refer to 4.4.2 Setup from Epson RC+.)

B : Offline the Epson RC+.



Execute and stop the program from the control device specified by the Epson RC+. (Refer to 4.4.3 Setup Control Device.)

4.4.2 Setup from EPSON RC+

Switch the mode to Auto mode (AUTO) from the Epson RC+.

- (1) Select Epson RC+ menu-[Setup]-[System Configuration] to display the [System Configuration] dialog.

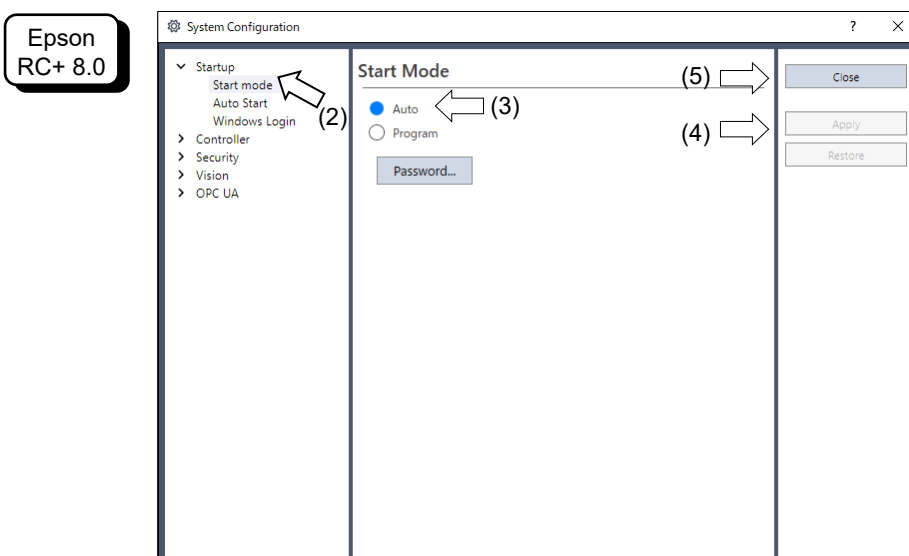
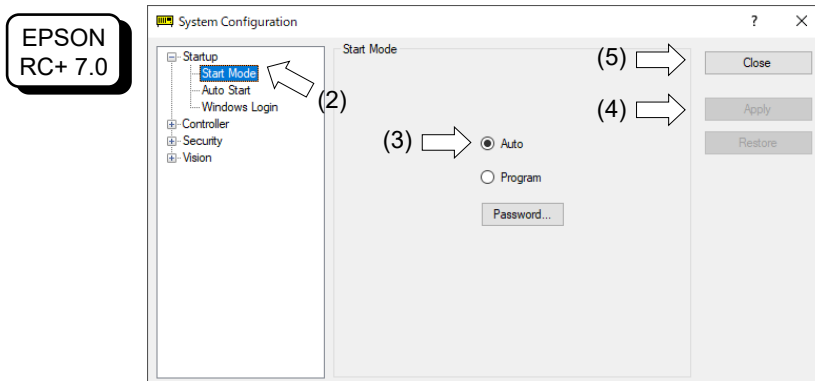

- (2) Select [Startup]-[Start Mode].
- (3) Select <Auto> button.
- (4) Click the <Apply> button.
- (5) Click the <Close> button.

4.4.3 Setup from Control Device

Set the control device from Epson RC+.

- (1) Select Epson RC+ menu-[Setup]-[System Configuration] to display the [System Configuration] dialog.

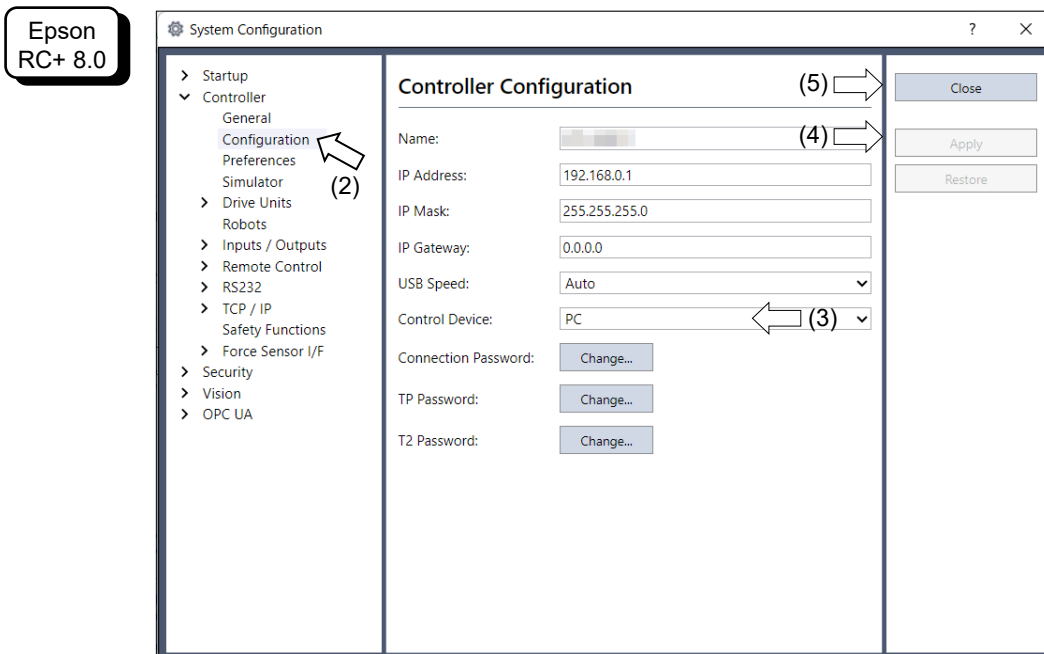
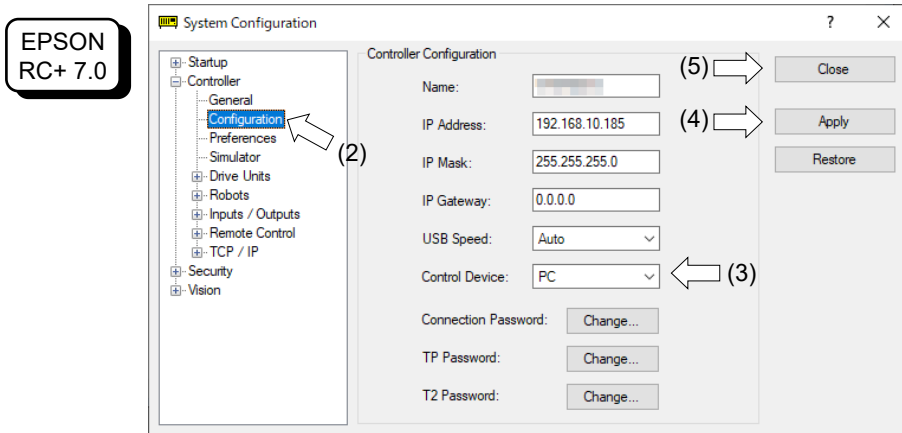

- (2) Select [Controller]-[Configuration].
- (3) Select [Setup Controller]-[Control Device] to select the control device from the following two types.
 - PC
 - Remote I/O
- (4) Click the <Apply> button.
- (5) Click the <Close> button.

5. Development PC Connection USB Port

Development PC connection USB port (USB B series connector)

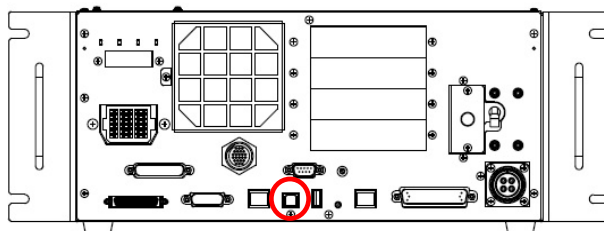

NOTE



- For other details of development PC and Controller connection, refer to *Epson RC+ User's Guide - [PC to Controller Communications] Command (Setup Menu)*.
- For RC700-D, be sure to install the Epson RC+ to the development PC first, then connect the development PC and RC700-D with the USB cable.
If RC700-D and the development PC are connected without installing the Epson RC+ to the development PC, [Add New Hardware Wizard] appears. If this wizard appears, click the <Cancel> button.

5.1 About Development PC Connection USB Port

The development PC connection port supports the following USB types.

- USB2.0 HighSpeed/FullSpeed (Speed auto selection, or FullSpeed mode)
- USB1.1 FullSpeed

Interface Standard: USB specification Ver.2.0 compliant
(USB Ver.1.1 upward compatible)

Connect the Controller and development PC by a USB cable to develop the robot system or set the Controller configuration with the Epson RC+ software installed in the development PC.

Development PC connection port supports hot plug feature. Cables insert and remove from the development PC and the Controller is available when the power is ON.

However, stop occurs when USB cable is removed from the Controller or the development PC during connection.

5.2 Precaution

When connecting the development PC and the Controller, make sure of the following:

- Connect the development PC and the Controller with a 5 m or less USB cable.
Do not use the USB hub or extension cable.
- Make sure that no other devices except the development PC are used for development PC connection port.
- Use a PC and USB cable that supports USB2.0 HighSpeed mode to operate in USB2.0 HighSpeed mode.
- Do not pull or bend the cable strongly.
- Do not allow unnecessary strain on the cable.
- When the development PC and the Controller are connected, do not insert or remove other USB devices from the development PC. Connection with the Controller may be lost.

5.3 PC and Controller Connection Using Development PC Connection USB Port

Connection of the development PC and the Controller is indicated.

- (1) Make sure that software Epson RC+ is installed to the Controller connected to the development PC.
(Install the software when it is not installed. Refer to *Safety Manual* or *Epson RC+ User's Guide*.)
- (2) Connect the development PC and the Controller using a USB cable.
- (3) Turn ON the Controller.
- (4) Start Epson RC+.
- (5) Select the Epson RC+ menu-[Setup]-[PC to Controller Communications] to display the [PC to Controller Communications] dialog.

EPSON RC+ 7.0

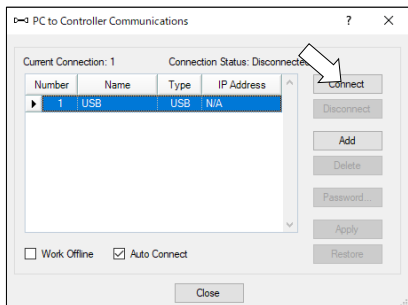

Epson RC+ 8.0

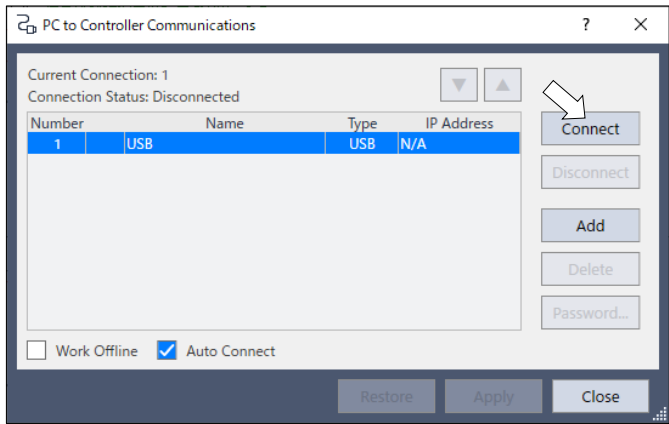

- (6) Select "No.1 USB" and click the <Connect> button.

- (7) After the development PC and the Controller connection has completed, “Connected” is displayed at [Connection status]. Make sure that “Connected” is displayed and click the <Close> button to close the [PC to Controller Communications] dialog.

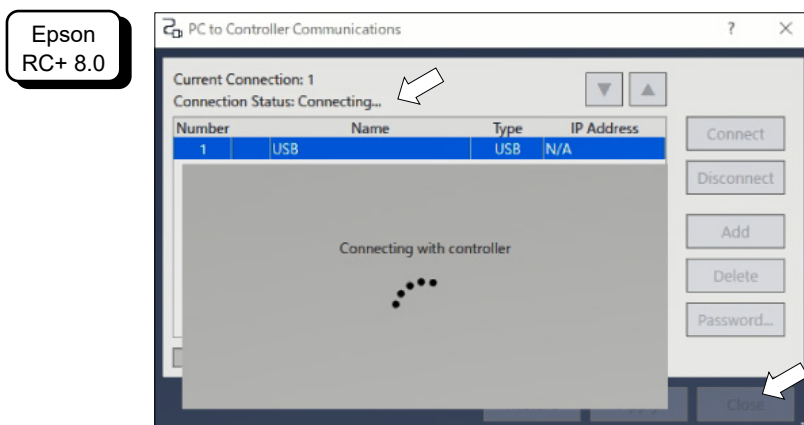
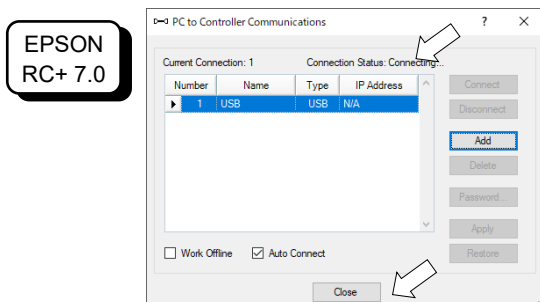

The connection between the development PC and the Controller is completed. Now the robot system can be used from Epson RC+.

5.4 Disconnection of Development PC and Controller

This section describes how to disconnect the development PC and the Controller communication.

- (1) Select the Epson RC+ menu-[Setup]-[PC to Controller Communications] to display the [PC to Controller Communications] dialog.
- (2) Click the <Disconnect> button.
Communication between the Controller and the development PC is disconnected and the USB cable can be removed.



NOTE If the USB cable is removed when the Controller and the development PC are connected, the Robot will stop. Be sure to click the <Disconnect> button in the [PC to Controller Communications] dialog before USB cable is removed.

5.5 How to Fix USB Cable

This section describes how to fix USB cables.

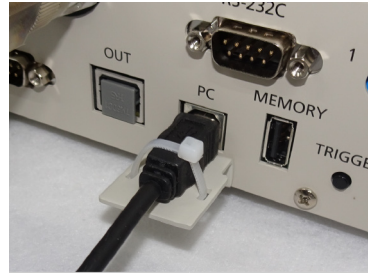
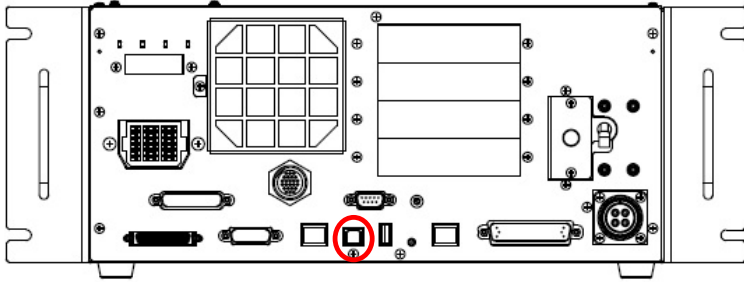

- (1) Unscrew the screw below the USB port.
- (2) Secure the fixing clamp (attached) using the screw in Step (1).
- (3) Connect the USB cable to the USB port.
- (4) Get an attached cable tie through a hole of the fixing clamp in Step (2) and fix the USB cable.
- (5) Adjust the length of the cable tie by cutting it.

6. Memory Port

Connect a commercial USB memory to the Controller memory port to use the Controller backup function to the USB memory.

6.1 What is Backup Controller Function?

This function saves various kinds of Controller data to the USB memory with one push. Data saved in the USB memory is loaded to Epson RC+ to get the status of the Controller and the program simply and accurately.

The saved data can also be used for restoring the Controller.

6.2 Before Using Backup Controller Function

6.2.1 Precautions

 CAUTION	<ul style="list-style-type: none"> ■ Backup Controller function is available at any time and in any Controller status after starting the Controller. However, operations from the console including stop and pause are not available while executing this function. Also, this function influences the robot cycle time and the communication with Epson RC+. Other than only when it is necessary, do not execute this function when operating the robot.
---	--

- Make sure that the USB port is used only for USB memory even though the port on the Controller is a universal USB port.
- Insert the USB memory directly into the Controller memory port. Connection with cables or hubs between the Controller and the USB memory is not assured.
- Insert and remove the USB memory slowly and surely.
- Do not edit the saved files by the editor. Operation of the robot system after data restoration to the Controller is not assured.

6.2.2 Adoptable USB Memory

Use USB memory that meets following conditions.

- USB2.0 supported
- Without security function
USB memory with password input function cannot be used.
- No installation of a driver or software is necessary for Windows 8, or Windows 10, or Windows 11.
(For supported operating systems for the Epson RC+, refer to *Epson RC+ User's Guide*.)

6.3 Backup Controller Function



6.3.1 Backup Controller with Trigger Button



CAUTION

- Controller status storage function is available at any time and in any Controller status after starting the Controller.
However, operations from the console including stop and pause are not available when executing this function.
Also, this function influences the robot cycle time and the communication with the Epson RC+. Do not execute this function while operating the robot except when it is necessary.

Use the following procedure to backup the Controller settings to USB memory.

- (1) Insert the USB memory into the memory port.
- (2) Wait approximately 10 seconds for USB memory recognition.
- (3) Press the trigger button on the Controller.
- (4) The seven-segment following two are displayed repeatedly during the data transfer.

 Wait until the display returns back to the former display. (Transfer time differs depending on the amount of data, such as the project size.)
- (5) When the storage has been completed, the following will be displayed on the seven-segment for two seconds.

 When the storage has failed, the following will be displayed on the seven-segment for two seconds.

- (6) Remove the USB memory from the Controller.



NOTE

- USB memory with LED is recommended to check the status changes in procedure (2).
- When storage is executed during Motor ON status, it may fail to store the status. Use another USB memory or execute the storage during Motor OFF status.

6.3.2 Load Data with Epson RC+

The procedure to read the data stored in the USB memory by Epson RC+ and display the Controller status is described in the following manual.

Epson RC+ User's Guide - [Controller] Command (Tools Menu)

6.3.3 Transfer with E-mail

Follow this procedure to transfer the data by e-mail that was saved to the USB memory.

- (1) Insert the USB memory to a PC that supports sending of e-mail.
- (2) Make sure that the USB memory has following folders.
 BU_Controller type_serial number_backup date
 → Example: BU_RC700_12345_2013-10-29-092951



(3) Compress the folders checked in Step (2), then send them by e-mail.

- Delete files that do not relate to the project before transfer.
- This function is used to send the data to the system director and EPSON from the end users for problem analysis.

6.4 Details of Data

The following data files are created by the Controller backup function.

File Name	Outline	
Backup.txt	Information file for restore	File with information for Controller restore.
CurrentMnp01.PRM	Robot parameter	Saves information such as ToolSet.
CurrentStatus.txt	Save status	Saves program and I/O status.
ErrorHistory.csv	Error history	
InitFileSrc.txt	Initial setting	Saves various settings of the Controller.
MCSys01.MCD	Robot setting	Saves information of connected robot.
SrcmcStat.txt	Hardware information	Saves installation information of hardware.
ProjectName.obj	OBJ file	Result of project build. Prg file is not included.
GlobalPreserves.dat	Global Preserve variables	Saves values of Global Preserve variables.
MCSRAM.bin MCSYSTEMIO.bin MCTABLE.bin MDATA.bin SERVOSRAM.bin VXDWORK.bin	Inner information of Robot operation	
WorkQueues.dat	WorkQue information	Saves information of Queues information of the WorkQue.
All files related to project except ProjectName.obj *1	Project	Select Epson RC+ menu-[Setup]- [System Configuration] to display the [System Configuration] dialog. When [Include project files when status exported] check box is checked in [Controller]-[Preferences], the project file is stored. Includes program files.

*1 Storage of “All files related to project except ProjectName.obj” can be specified by a setting.

7. LAN (Ethernet Communication) Port

- NOTE**  - Refer to *Epson RC+ User's Guide - [PC to Controller Communications] Command (Setup Menu)* for other details for the development PC and Controller connection.
- For Ethernet (TCP/IP) communication with robot application software, refer to *Epson RC+ Online Help* or *User's Guide - TCP/IP Communications*.

7.1 About the LAN (Ethernet Communication) Port

Ethernet communication port supports 100BASE-TX / 10 BASE-T.
 This port is used for two different purposes.

Connection with development PC

LAN (Ethernet communication) port is used for connection of the Controller and the development PC.

Equivalent operation is available to connect between the Controller and the development PC with the development PC connection port.

(Refer to 7. *Development PC Connection USB Port*)

Connection with other Controller or PC

The LAN (Ethernet communication) port can be used as an Ethernet (TCP/IP) communication port to communicate between multiple controllers from robot application software.

CAUTION

■ OUT connector is not a LAN (Ethernet communication) port. Do not connect a cable.

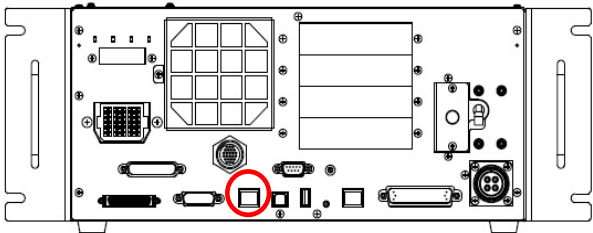

7.2 IP Address

From the following firmware version password authentication is required when connecting Controllers and PCs to a global accessible network.

F/W: Ver.7.4.8.x

- NOTE**  For the details of password setting, refer to the *User's Guide - Setting Password for PC Ethernet Controller Connection*.

Our robot system is provided on the assumption that customers use it in the closed local area networks. We considered the setting of the global IP address is access to the Internet and changed the specification to perform password authentication in order to secure the connections.

Password authentication is not performed in case of USB connections.

Be sure to use the following private IP addresses.

Private Address List

10.0.0.1	to	10.255.255.254
172.16.0.1	to	172.31.255.254
192.168.0.1	to	192.168.255.254

The following is the configuration of the Controller at delivery.

IP Address : 192.168.0.1
 IP Mask : 255.255.255.0
 IP Gateway : 0.0.0.0

Set separate IP addresses in the same subnet for PC and the Controller.

PC : 192.168.0.10
 Controller : 192.168.0.1

7.3 Changing Controller IP Address

This section describes the procedure to change the Controller IP address.

- (1) Connect between the development PC and the Controller using the USB cable by referring to 5. *Development PC Connection USB Port*.

- (2) Select the Epson RC+ 7.0 menu-[Setup]-[Controller] to display the following dialog.
- (3) Select [Controller]-[Configuration].

EPSON RC+ 7.0

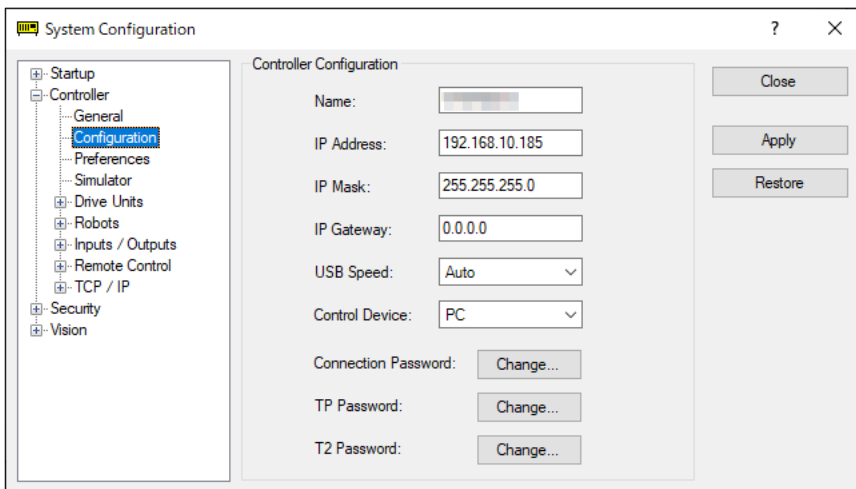

Epson RC+ 8.0

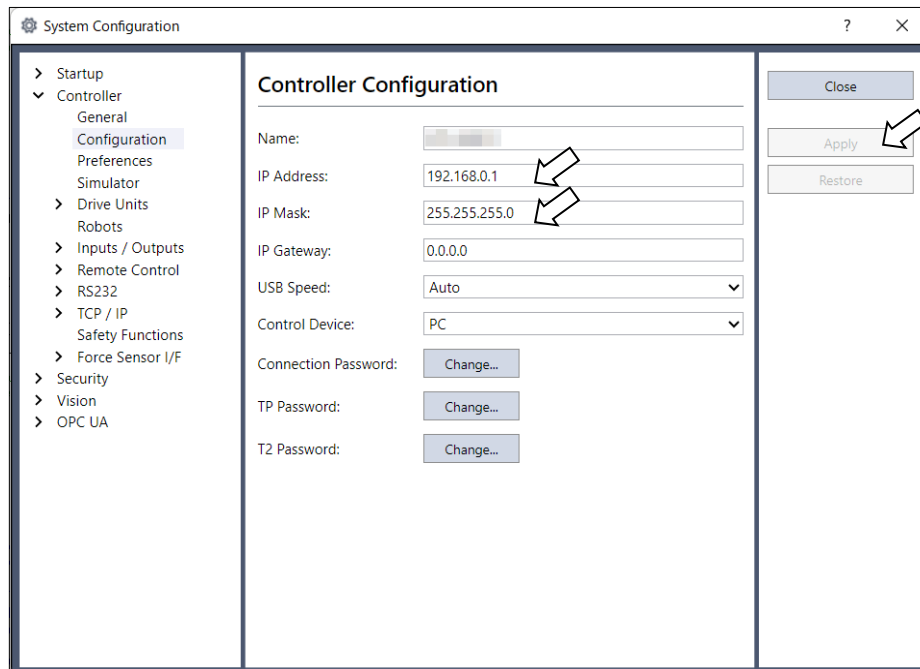

- (4) Enter the proper IP address and subnet mask and click the <Apply> button.
- (5) Click the <Close> button. The Controller reboots automatically.
IP address configuration is completed and the Controller reboot dialog disappears.

7.4 Connection of Development PC and Controller with Ethernet

Connection between the development PC and the Controller is shown below.

- (1) Connect the development PC and the Controller using the Ethernet cable.
- (2) Turn ON the Controller.
- (3) Start Epson RC+.
- (4) Display the [PC to Controller Communication] dialog from [Setup] in Epson RC+ menu.
- (5) Click the <Add> button.

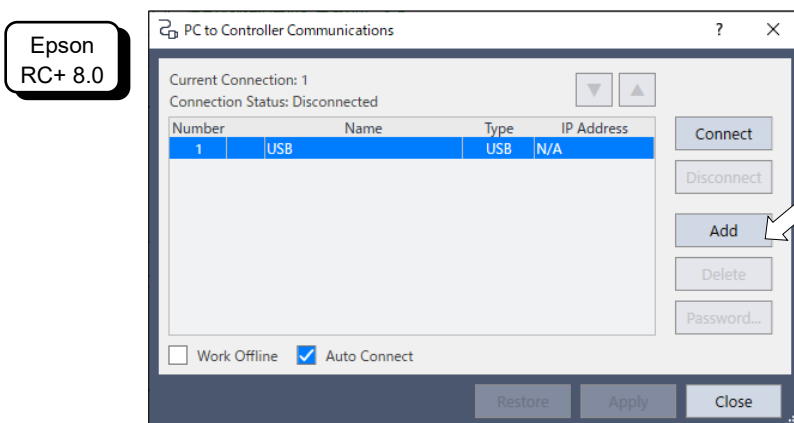
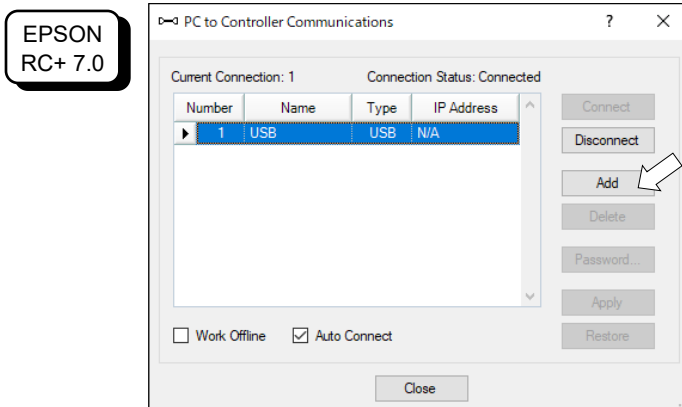

- (6) Connection “No.2” is added. Set the following and click the <Apply> button.
 Name : Valid value to identify the Controller to connect
 IP Address : IP address for Controller to connect

EPSON
RC+ 7.0

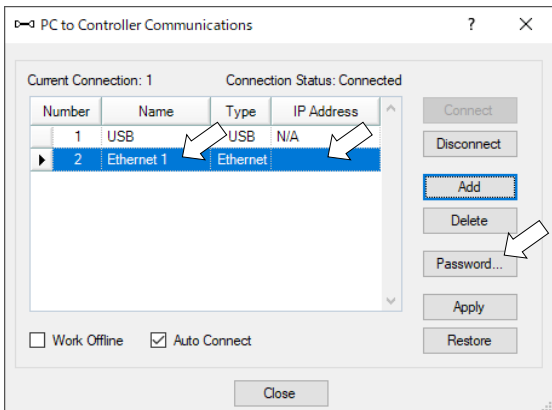

Epson
RC+ 8.0

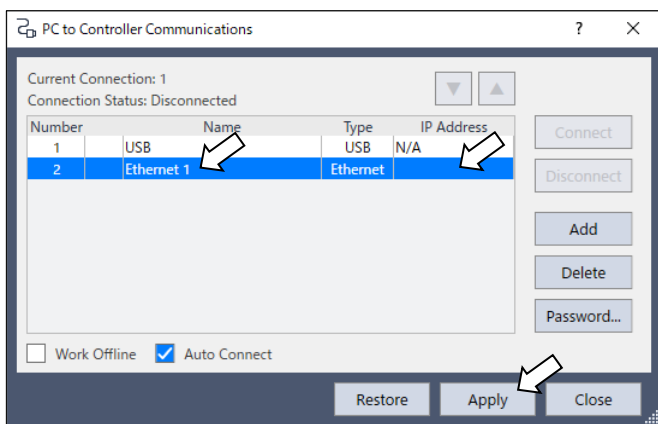

- (7) [Name] and [IP Address] specified in procedure (6) is displayed.

EPSON
RC+ 7.0

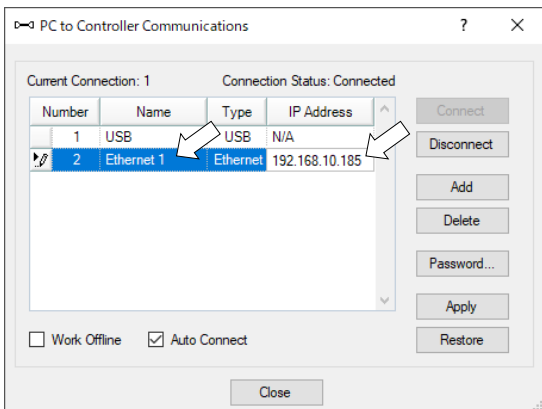

Epson
RC+ 8.0

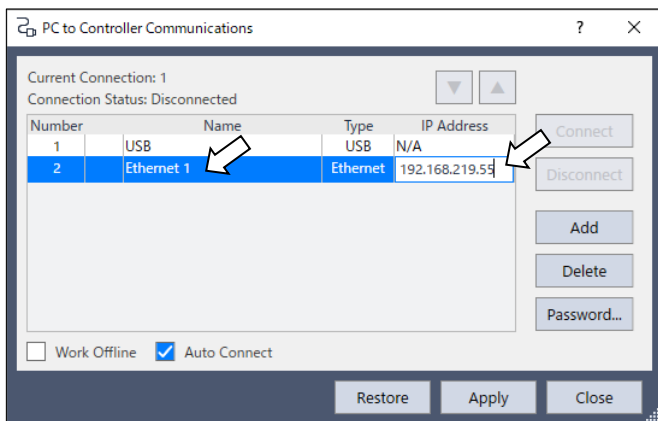

(8) Make sure that “No.2” is selected, and click the <Connect> button.

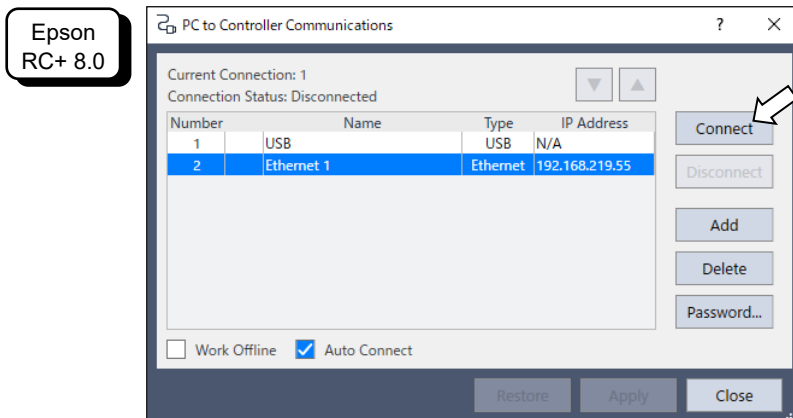
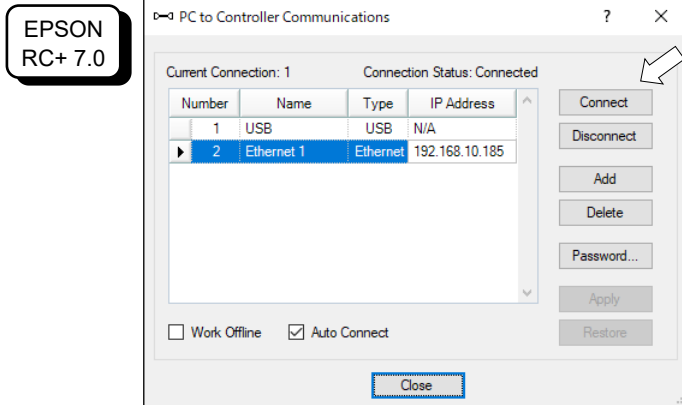

- (9) After the development PC and Controller connection is completed, “Connected” is displayed in the [Connection status:]. Make sure that “Connected” is displayed and click the <Close> button to close the [PC to Controller Communications] dialog.

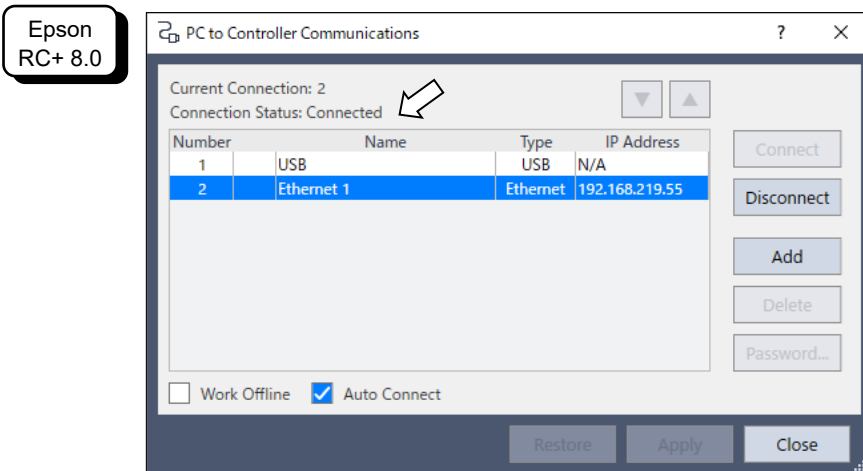
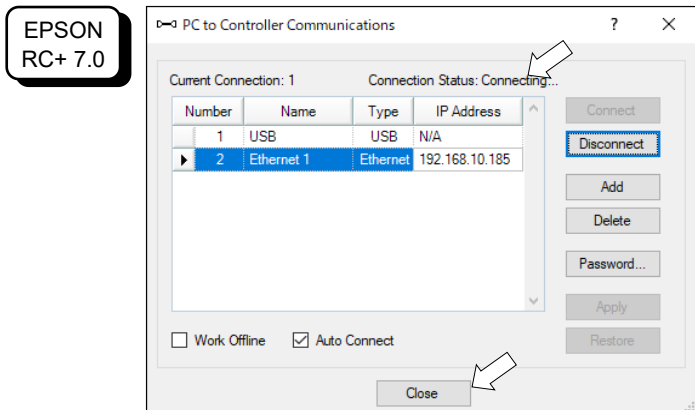

Connection between the development PC and the Controller is complete. Now the robot system can be used via an Ethernet connection from Epson RC+.

7.5 Disconnection of Development PC and Controller with Ethernet

Disconnection of the development PC and the Controller is shown below.

- (1) Display [PC-Controller Connection] dialog from [Setup] in Epson RC+ menu.
- (2) Click the <Disconnect> button.

Communication between the Controller and the development PC is disconnected and the Ethernet cable can be removed.



If the Ethernet cable is removed when the Controller and the development PC is connected, Emergency Stop occurs and the Robot stops. Be sure to click the <Disconnect> button in the [PC to Controller Communications] dialog before the Ethernet cable is removed.

8. TP Port

8.1 What is the TP Port?

The TP port connects the Teach Pendant TP2, TP3, and TP4 to the Controller.

When connecting TP2 to RC700-D, the RC700-A/RC700-D conversion cable* is necessary.

If you need the conversion cable, please contact the supplier of your region.

* RC700-A TP Exchange Cable: R12NZ900L6

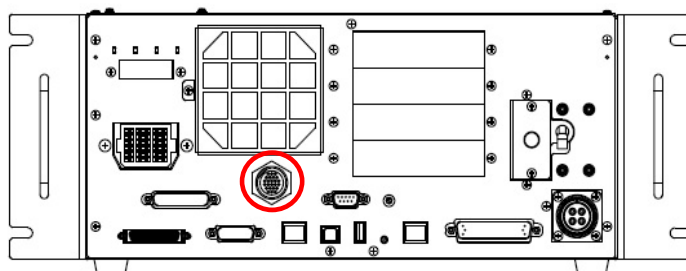

NOTE



When nothing is connected to the TP port, Emergency Stop status occurs in the Controller. When the Teach Pendant is not connected, connect the TP bypass plug.

Save the removed TP in place so that it can be distinguished from the TP connected to the controller.

Do not connect the following devices to the TP port of / RC700-D. Connecting these devices may result in malfunction of the device since the pin assignments are different.

- OPTIONAL DEVICE dummy plug
- Operation Pendant OP500
- Operator Pendant OP500RC
- Jog Pad JP500
- Teaching Pendant TP-3**
- Operator Panel OP1

Extended Enable cannot be connected. Use the Enable comes with the TP.

8.2 Teach Pendant Connection

A cable for connection to the RC700 / RC700-A / RC700-D Controller is attached to the Teach Pendant. Connect this cable connector to the TP port.

Communication is set automatically. Enable the Teach Pendant by one of the following procedures.

A: Insert the Teach Pendant connector to the Controller and turn ON the Controller.

B: Insert the Teach Pendant connector while the Controller is turned ON.

NOTE



- Teach Pendant connection and disconnection from the Controller are allowed when the Controller power is ON.
- When the Teach Pendant connector is removed from the Controller with the mode selector key switch of the Teach Pendant in the “Teach” position, the operation mode will remain in the TEACH mode. The operation mode cannot be switched to AUTO mode. Be sure to remove the Teach Pendant after switching the operation mode to “Auto” mode.
- Manager control taking off or storage of the Teach Pendant. Do not touch it unless the administrator approves it. When storing, keep the Teach Pendant in a way that you can clearly check that it is not connected to the Controller.

For details, refer to the following manuals:

Robot Controller Option Teach Pendant TP2

Robot Controller Option Teach Pendant TP3

Robot Controller Option Teach Pendant TP4

External enable switch cannot be connected to the TP port. Use the enable switch provided with the TP.

9. EMERGENCY

NOTE  The details of safety requirements for this section are described in the *User's Guide - Safety*. Please refer to them to keep the robot system safe.

 CAUTION	<ul style="list-style-type: none"> ■ Make sure that the emergency stop and safety door work properly before using the system, not only when setting up the system, but also when the use environment is changed.
---	---

Connect a safeguard switch or Emergency Stop switch to the Controller EMERGENCY connector for safety.

When nothing is connected to the EMERGENCY connector, the robot system does not operate normally.

 CAUTION	<p>Before connecting the connector, make sure that the pins are not bent. Connecting with the pins bent may damage the connector and result in malfunction of the robot system.</p>
---	---

EMERGENCY Connector

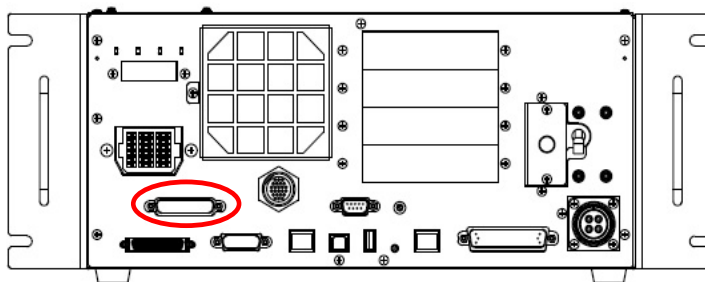

9.1 Safety Door Switch and Latch Release Switch

The EMERGENCY connector has input terminals for the Safety Door switch and the Emergency Stop switch. Be sure to use these input terminals to keep the system safe.

Connector	Standard
EMERGENCY connector (Controller side)	D-sub 25 male pin Screwlock #4 - 40

* The E-STOP BOX, EMERGENCY connector cable, terminal block, and EMERGENCY connector kit are offered as options.

9.1.1 Safety Door Switch

 WARNING	<ul style="list-style-type: none"> ■ The interlock of the Safety Door must be functioning when the robot system is operated. Do not operate the system under the condition that the switch cannot be turned ON/OFF (e.g. The tape is put around the switch.). Operating the robot system when the switch is not functioning properly is extremely hazardous and may cause serious safety problems as the Safety Door input cannot fulfill its intended function.
--	---

In order to maintain a safe working zone, a safeguard must be erected around the Manipulator. The safeguard must have an interlock switch at the entrance to the working zone. The Safety Door that is described in this manual is one of the safeguards and an interlock of the Safety Door is called a Safety Door switch. Connect the Safety Door switch to the Safety Door input terminal on the EMERGENCY connector.

The Safety Door switch has safety features such as temporary hold-up of the program or the operation-prohibited status that are activated whenever the Safety Door is opened.

Observe the followings in designing the Safety Door switch and the Safety Door.

- For the Safety Door switch, select a switch that opens as the Safety Door opens, and not by the spring of the switch itself.
- The signal from the Safety Door (Safety Door input) is designed to input to two redundant signals. If the signals at the two inputs differ by two seconds or more, the system recognizes it to be a critical error. Therefore, make sure that the Safety Door switch has two separate redundant circuits and that each connects to the specified pins at the EMERGENCY connector on the Controller.
- The Safety Door must be designed and installed so that it does not close accidentally.

9.1.2 Latch Release Switch

The Controller software latches these conditions:

- The safety door is open.
- The operation mode is set to “TEACH”.

The EMERGENCY connector has an input terminal for a latch release switch that cancels the latched conditions.

Open : The latch release switch latches conditions that the safety door is open or the operation mode is “TEACH”.

Closed : The latch release switch releases the latched conditions.

NOTE



When the latched TEACH mode is released while the safety door is open, the status of Manipulator power is operation-prohibited because the safety door is open at that time.

To execute a Manipulator operation, close the safety door again, and then close the latch release input.

9.1.3 Checking Latch Release Switch Operation

After connecting the safety door switch and latch release switch to the EMERGENCY connector, be sure to check the switch operation for safety by following the procedures described below before operating the Manipulator.

- (1) Turn ON the Controller while the safety door is open in order to boot the Controller software.
- (2) Make sure that “Safety” is displayed on the main window status bar.
- (3) Close the safety door, and turn ON the switch connecting to the latch release input. Make sure that the “Safety” is dimmed on the status bar.

The information that the safety door is open can be latched by software based on the latch release input condition. To cancel the condition, close the safety door, and then close the safety door latch release input.

Open : The latch release switch latches the condition that the safety door is open.

Closed : The latch release switch does not latch the condition that the safety door is open.

NOTE



The latch release input also functions to acknowledge the change of to TEACH mode.

In order to change the latched condition of TEACH mode, turn the mode selector key switch on the Teach Pendant to “Auto”. Then, close the latch release input.

9.2 Emergency Stop Switch Connection

9.2.1 Emergency Stop Switch

If it is desired to add an external Emergency Stop switch(es) in addition to the Emergency Stop on the Teach Pendant and Operator Panel, be sure to connect such Emergency Stop switch(es) to the Emergency Stop input terminal on the EMERGENCY connector.

The Emergency Stop switch connected must comply with the related safety standards (such as IEC60947-5-5) and the following:

- It must be a push button switch that is “normally closed”.
- A button that does not automatically return or resume.
- The button must be mushroom-shaped and red.
- The button must have a double contact that is “normally closed”.

NOTE



The signal from the Emergency Stop switch is designed to use two redundant circuits. If the signals at the two circuits differ by two seconds or more, the system recognizes it as a critical error. Therefore, make sure that the Emergency Stop switch has double contacts and that each circuit connects to the specified pins on the EMERGENCY connector at the Controller. Refer to the *9.4 Circuit Diagrams*. Make sure to give the emergency stop function to all the places where have the activation control.

9.2.2 Checking Emergency Stop Switch Operation

Once the Emergency Stop switch is connected to the EMERGENCY connector, continue the following procedure to make sure that the switch functions properly. For the safety of the operator, the Manipulator must not be powered ON until the following test is completed.

- (1) Turn ON the Controller to boot the Controller software while pressing the Emergency Stop switch.
- (2) Make sure that E-STOP LED of the Controller is lighting.
- (3) Make sure that “EStop” is displayed on the status bar on the main window.
- (4) Release the Emergency Stop Switch.
- (5) Execute the RESET command.
- (6) Make sure that E-STOP LED is turned OFF and that “EStop” is dimmed on the main window status bar.

9.2.3 Recovery from Emergency Stop

To recover from the emergency stop condition, follow the procedure of safety check as required by the system.

After safety check, the operations below are required to recover from the emergency stop condition.

- Release the Emergency Stop Switch
- Execute the RESET command

9.3 Pin Assignments

The EMERGENCY connector pin assignments are as follows:

Pin No.	Signal	Function	Pin No.	Signal	Function
1	ESW11	Emergency Stop switch contact (1) *3	14	ESW21	Emergency Stop switch contact (2) *3
2	ESW12	Emergency Stop switch contact (1) *3	15	ESW22	Emergency Stop switch contact (2) *3
3	ESTOP1+	Emergency Stop circuit 1 (+) *4	16	ESTOP2+	Emergency Stop circuit 2 (+) *4
4	ESTOP1-	Emergency Stop circuit 1 (-) *4	17	ESTOP2-	Emergency Stop circuit 2 (-) *4
5	Not Used	*1	18	SDLATCH1	Safety Door Latch Release
6	Not Used	*1	19	SDLATCH2	Safety Door Latch Release
7	SD11	Safety Door input (1) *2	20	SD21	Safety Door input (2) *2
8	SD12	Safety Door input (1) *2	21	SD22	Safety Door input (2) *2
9	24V	+24V output	22	24V	+24V output
10	24V	+24V output	23	24V	+24V output
11	24VGND	+24V GND output	24	24VGND	+24V GND output
12	24VGND	+24V GND output	25	24VGND	+24V GND output
13	Not Used				

*1 Do not connect anything to these pins.

*2 A critical error occurs if the input values from the Safety Door 1 and Safety Door 2 are different for two or more seconds. They must be connected to the same switch with two sets of contacts.

*3 A critical error occurs if the input values from the Emergency Stop switch contact 1 and Emergency Stop switch contact 2 are different for two or more seconds. They must be connected the same switch with two sets of contacts.

*4 Do not apply reverse voltage to the Emergency Stop circuit.

Emergency Stop switch output rated load	+30 V 0.3 A or under	1-2, 14-15 pin
Emergency Stop rated input voltage range Emergency Stop rated input current	+24 V ±10% 37.5 mA ±10% /+24 V input	3-4, 16-17 pin
Safety Door rated input voltage range Safety Door rated input current	+24 V ±10% 10 mA/+24 V input	7-8, 20-21 pin
Latch Release rated input voltage range Latch Release rated input current	+24 V ±10% 10 mA/+24 V input	18-19 pin



The total electrical resistance of the Emergency Stop switches and their circuit should be 1 Ω or less.

 CAUTION	<ul style="list-style-type: none"> ■ The 24 V output is for emergency stop. Do not use it for other purposes. Doing so may result in system malfunction. ■ Do not apply reverse voltage to the Emergency Stop circuit. Doing so may result in system malfunction.
--------------------	---

9.4 Circuit Diagrams

9.4.1 Example 1: External emergency stop switch typical application

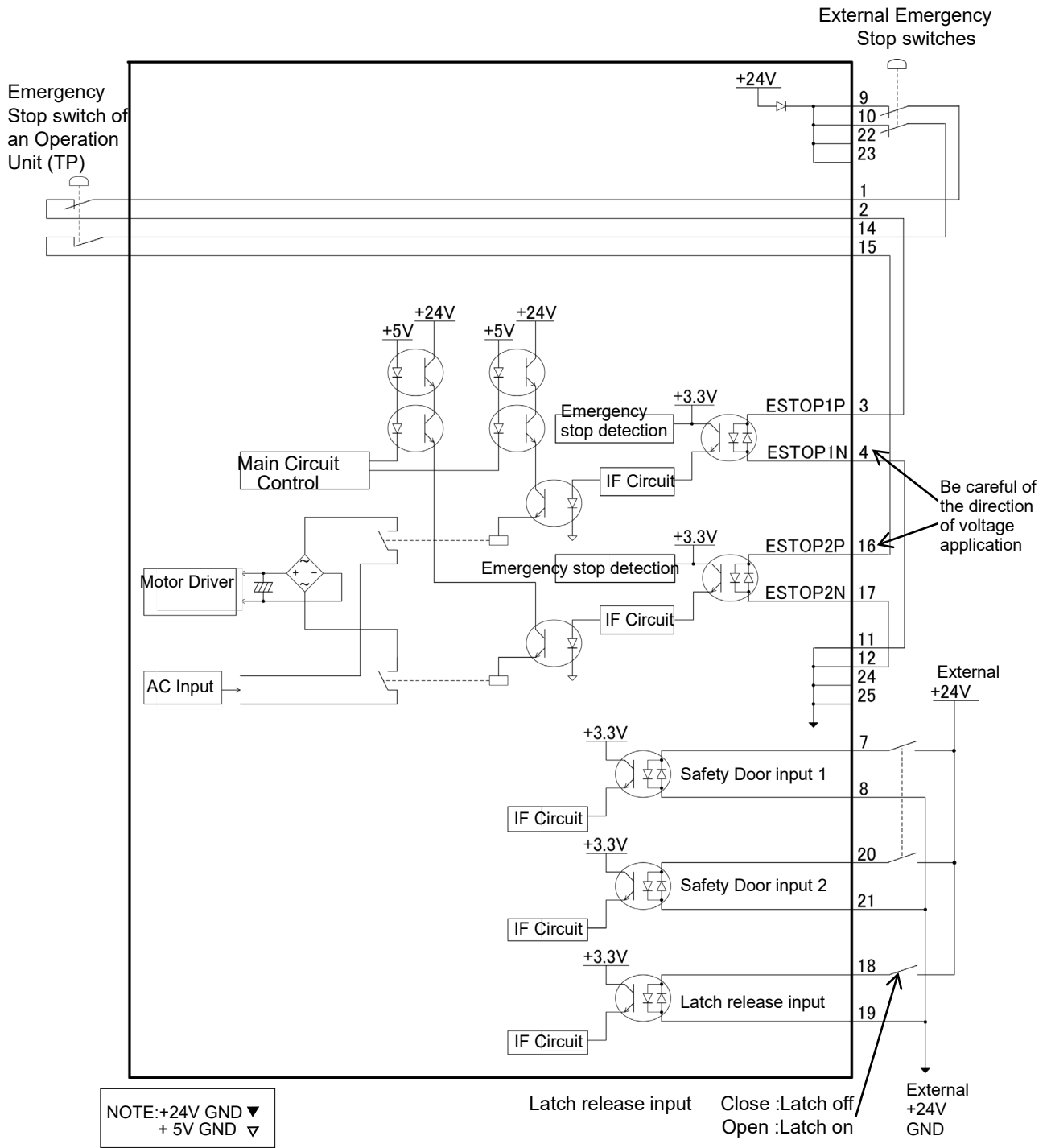

9.4.2 Example 2: External safety relay typical application

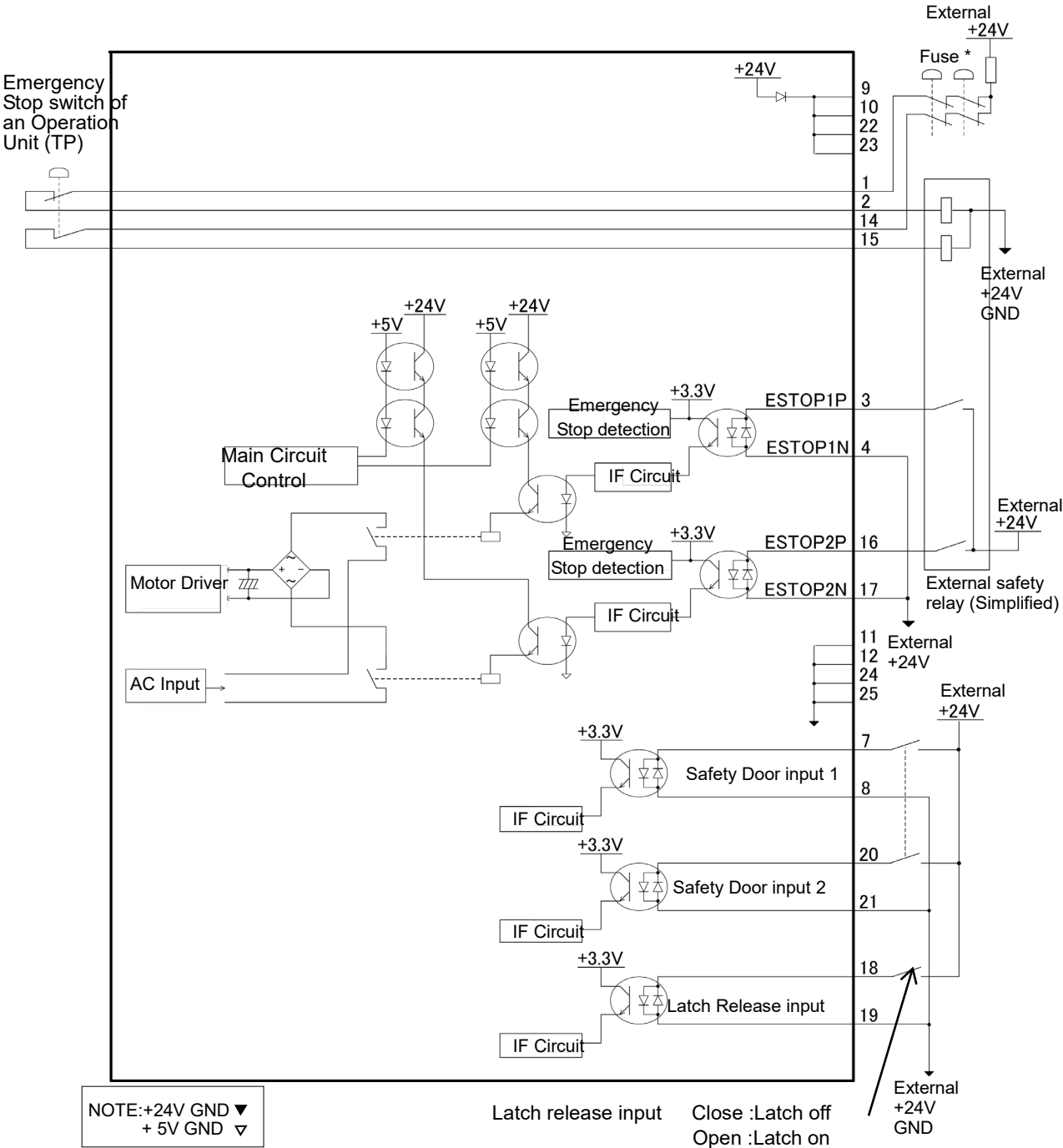

* To protect Emergency Stop Circuit, use the fuse that is 0.4A or under and matches amount of external safety relay.

10. Standard RS-232C Port

10.1 RS-232C Port

A standard RS-232C port is available with the Controller.

Mount the RS-232C board(s) in the option slot to communicate with external equipment with two or more RS-232C ports.

For the details of the expansion port, refer to *14.4 RS-232C Board*.

Port numbers are assigned as follows.

Port No.	Supported hardware
#1	Standard RS-232C connector
#2	First expansion RS-232C board CH1
#3	First expansion RS-232C board CH2
#4	Second expansion RS-232C board CH1
#5	Second expansion RS-232C board CH2

10.2 Confirmation with Epson RC+ (RS-232C)

When an RS-232C board is mounted in as option unit, the Controller software automatically identifies the RS-232C board. Therefore, no software configuration is needed. Correct identification can be confirmed from Epson RC+.

- (1) Select the Epson RC+ menu-[Setup]-[System Configuration] to display the [System Configuration] dialog.

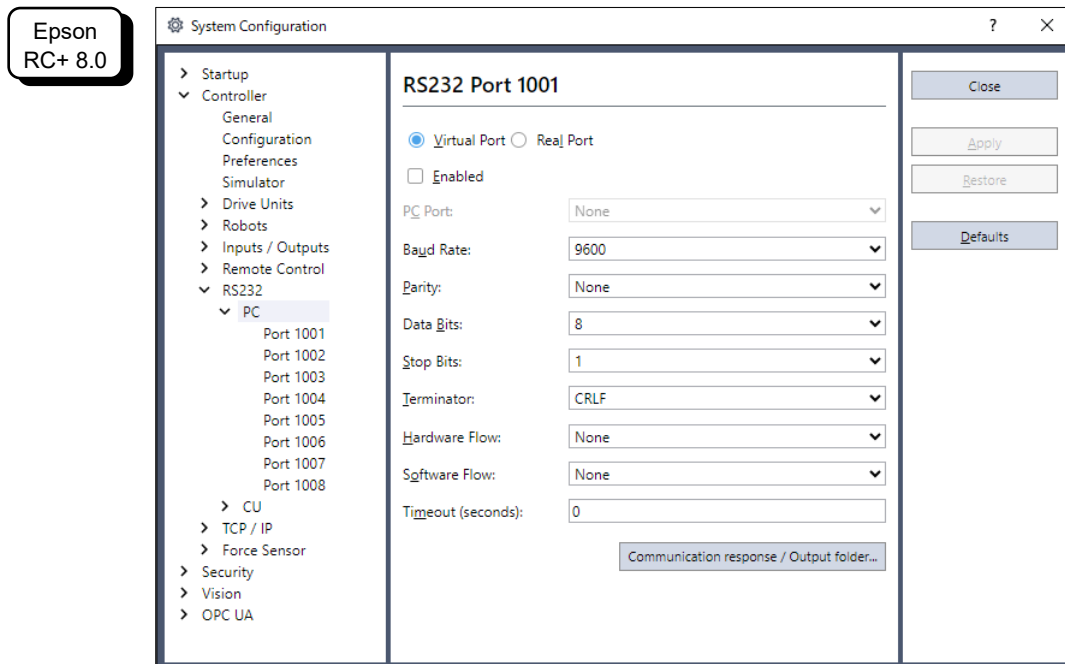
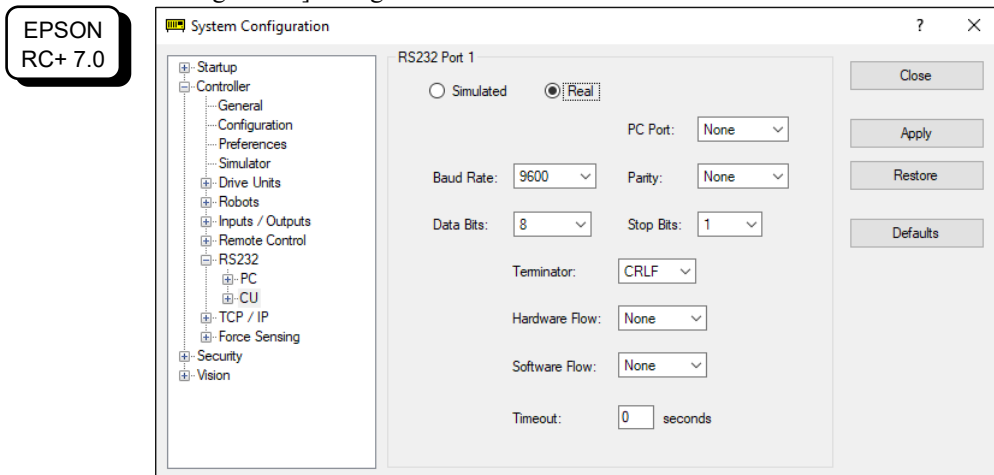

- (2) Select the [RS232]-[CU].

10.3 RS-232C Software Communication Setup (RS-232C)

Available communication settings are as follows.

Item	Specification
Baud Rates	110, 300, 600, 1200, 2400, 4800, 9600, 14400, 19200, 38400, 57600, 115200
Data bit length	7, 8
Stop bit length	1, 2
Parity	Odd, even, NA
Terminator	CR, LF, CRLF

Refer to *Epson RC+ Online Help* or *User's Guide – RS-232C Communications* for RS-232C communication from the Robot application.

10.4 Communication Cable (RS-232C)

Prepare a communication cable as described in this section.

Connector	Standard
RS-232C Connector (Controller side)	D-sub 9 male pin Screwlock #4 - 40

NOTE



Use twisted pair cable for shielded wire.

Clamp the shield to the hood for noise prevention.

Pin assign of the RS-232C connector is as follows.

Pin No	Signal	Function	Signal Direction
1	DCD	Data carrier detect	Input
2	RXD	Receive data	Input
3	TXD	Send data	Output
4	DTR	Terminal ready	Output
5	GND	Signal ground	-
6	DSR	Data set ready	Input
7	RTS	Request to send	Output
8	CTS	Clear to send	Input
9	RI	Ring indicator	Input

11. I/O Connector

The I/O connector is for connecting your input/output equipment to the system.

	Pins	Bit number
Input	24	0 to 23
Output	16	0 to 15

Refer to 14.2. Expansion I/O board.

For cable wiring, refer to the 3.5 Noise Countermeasures in order to prevent noise.

The remote function is initially assigned to the input 0 to 7 and output 0 to 8. For further details, refer to 12. I/O Remote Settings.

11.1 Input Circuit

Input Voltage Range	: +12 to 24 V \pm 10%
ON Voltage	: +10.8 V (min.)
OFF Voltage	: +5 V (max.)
Input Current	: 10 mA (TYP) at +24 V input

Two types of wiring are available for use with the two-way photo coupler in the input circuit.

11.1.1 Typical Input Circuit Application 1

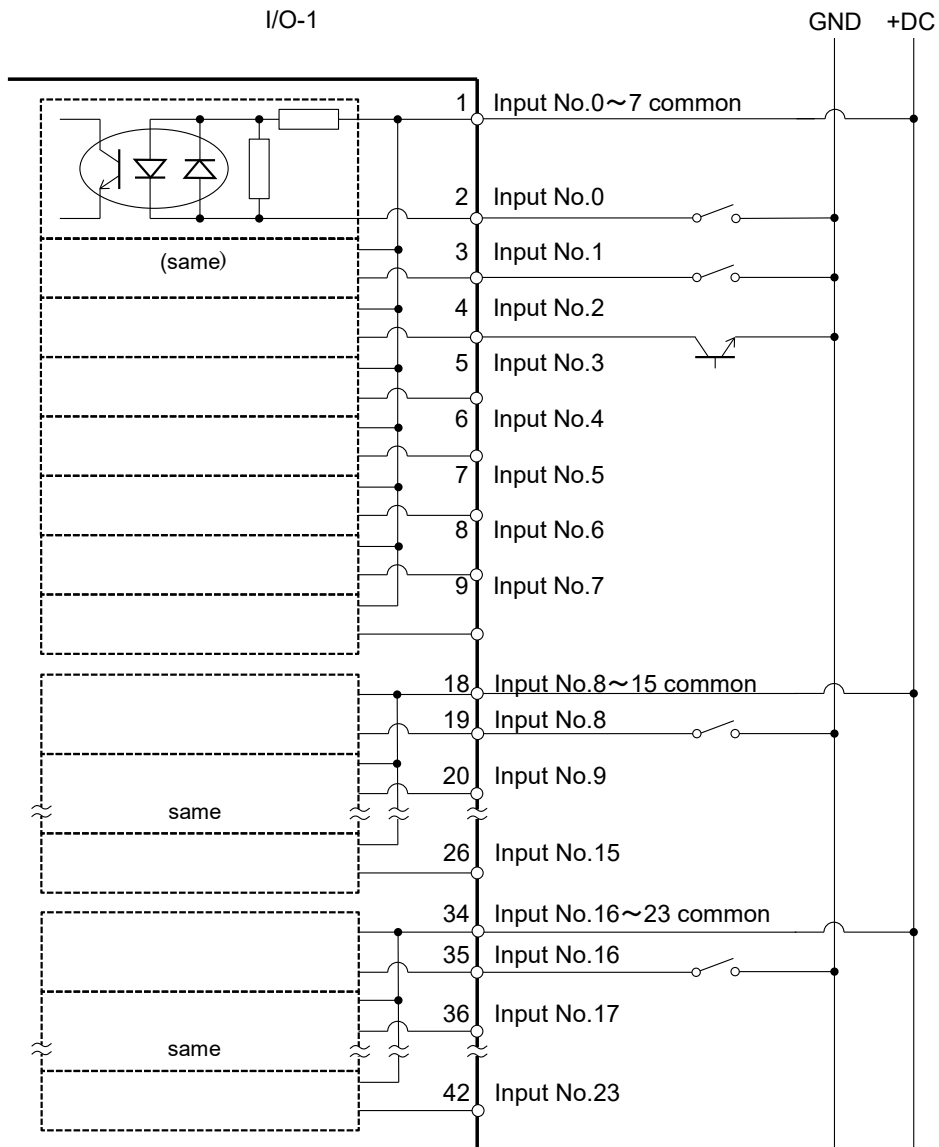

11.1.2 Typical Input Circuit Application 2

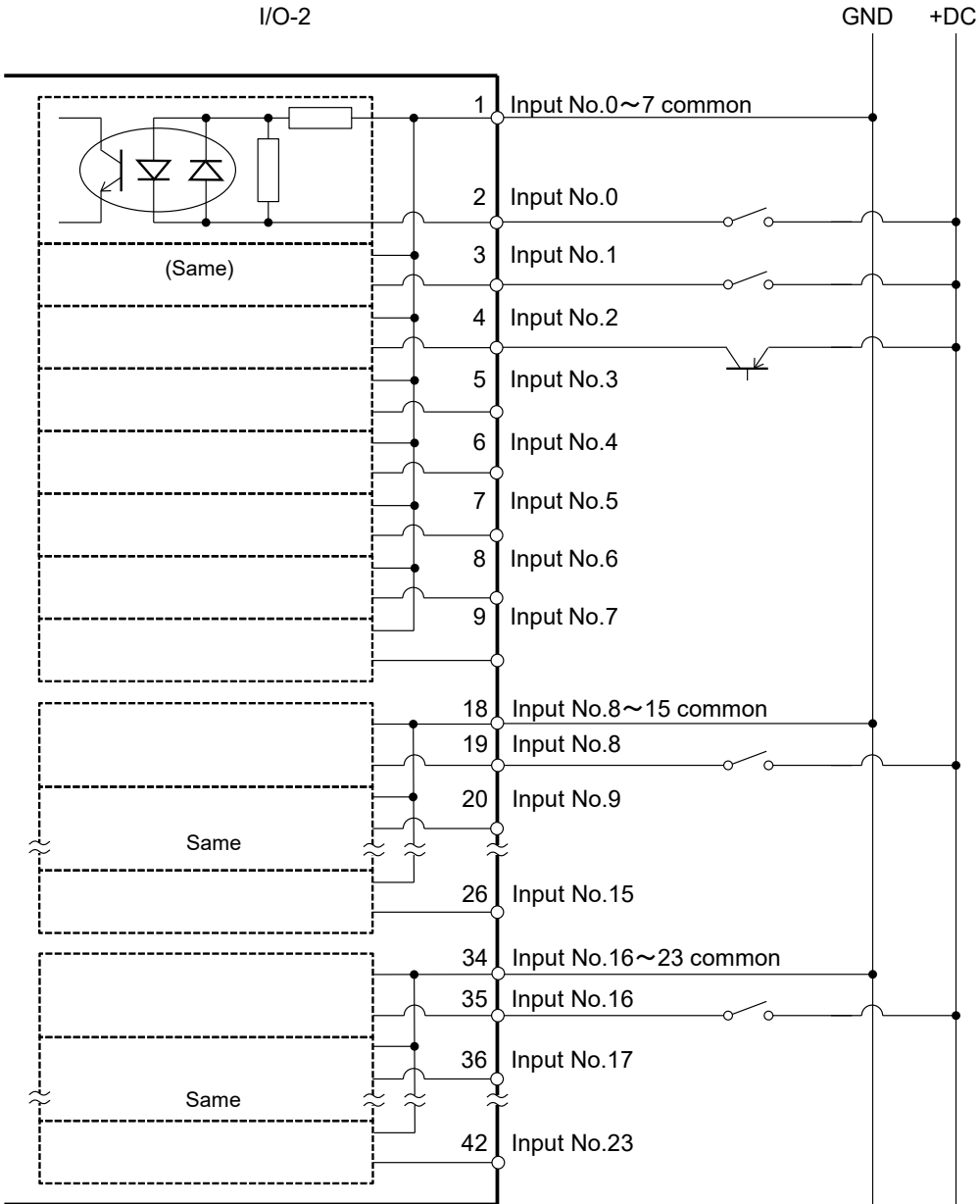

11.2 Output Circuit

- Rated Output Voltage : +12 V to 24 V ±10%
- Maximum Output Current : TYP 100 mA/1 output
- Output Driver : PhotoMOS Relay
- On-State Resistance (average) : 23.5 Ω or less

Two types of wiring are available for use with the nonpolar PhotoMOS relay in the output circuit.



CAUTION

Use Plus Common (PNP) to prevent the load from operating unintentionally if the wiring between the controller and the load is grounded fault. This conforms to European Machinery Directives.

Plus Common (PNP) connection

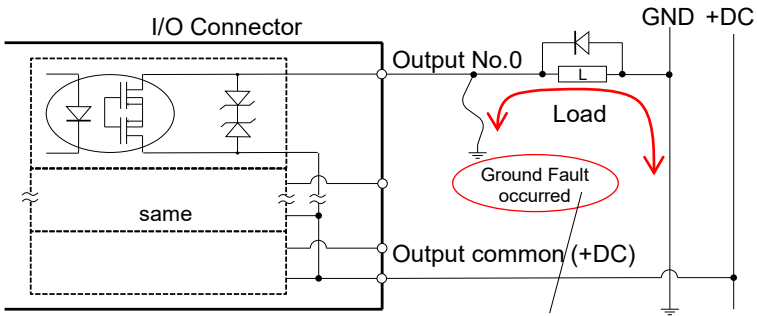

If there is ground fault, it does not flow to the load and does not start operate.

11.2.1 Typical Output Circuit Application 1: Sink Type (NPN)

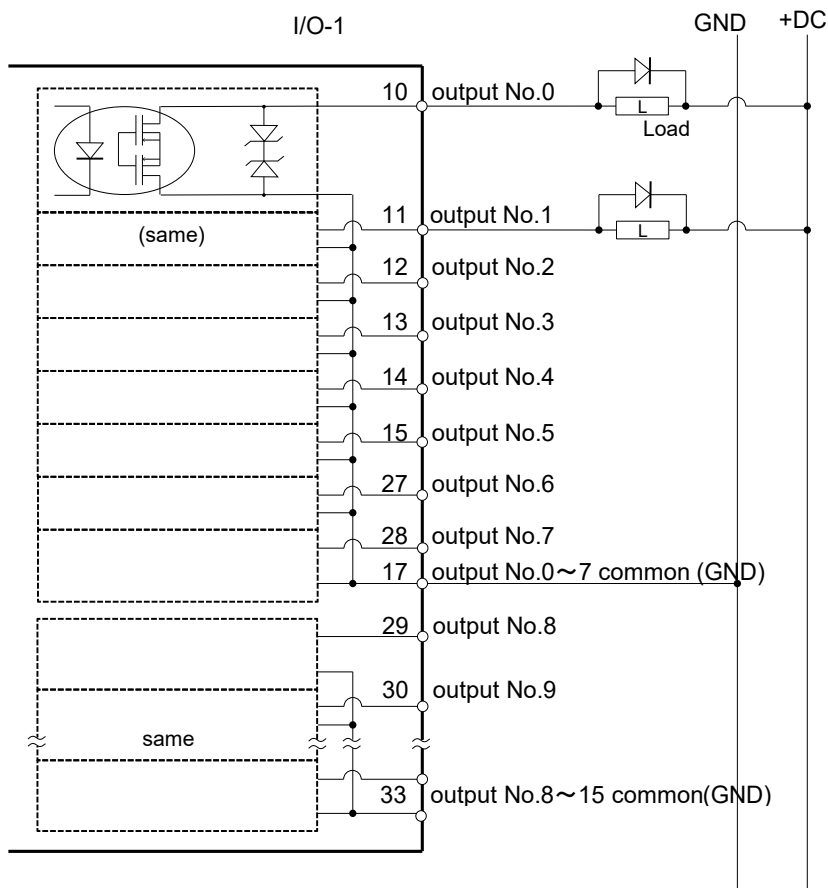

11.2.2 Typical Output Circuit Application 2: Source Type (PNP)

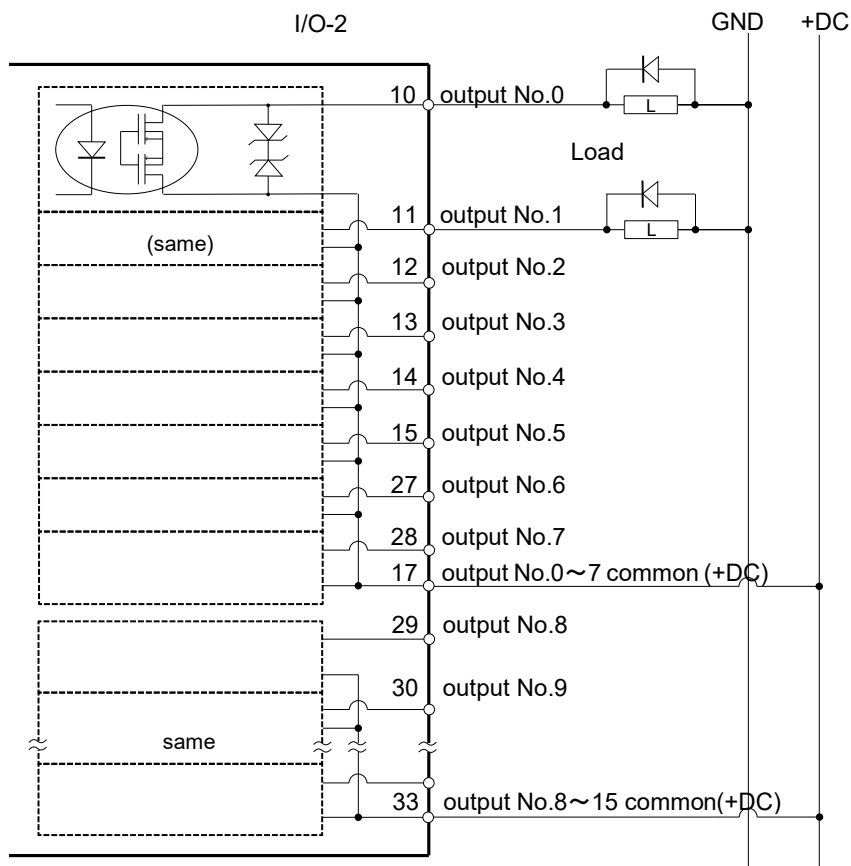

11.3 Pin Assignments

Pin No.	Signal Name	Pin No.	Signal Name	Pin No.	Signal Name
1	Input common No. 0 to 7	18	Input common No. 8 to 15	34	Input common No. 16 to 23
2	Input No. 0 (Start)	19	Input No. 8	35	Input No. 16
3	Input No. 1 (SelProg1)	20	Input No. 9	36	Input No. 17
4	Input No. 2 (SelProg2)	21	Input No. 10	37	Input No. 18
5	Input No. 3 (SelProg4)	22	Input No. 11	38	Input No. 19
6	Input No. 4 (Stop)	23	Input No. 12	39	Input No. 20
7	Input No. 5 (Pause)	24	Input No. 13	40	Input No. 21
8	Input No. 6 (Continue)	25	Input No. 14	41	Input No. 22
9	Input No. 7 (Reset)	26	Input No. 15	42	Input No. 23
10	Output No. 0 (Ready)	27	Output No. 6 (SError)	43	Output No.11
11	Output No. 1 (Running)	28	Output No. 7 (Warning)	44	Output No.12
12	Output No. 2 (Paused)	29	Output No. 8 (EstopOff)	45	Output No.13
13	Output No. 3 (Error)	30	Output No. 9	46	Output No.14
14	Output No. 4	31	Output No.10	47	Output No.15
15	Output No. 5 (SafeguardOn)	32	Not Used	48	Not Used
16	Not Used	33	Output common No. 8 to 15	49	Not Used
17	Output common No. 0 to 7			50	Not Used

The remote function inside () in the table above is initially assigned to the input 0 to 7 and output 0 to 8. To assign the remote function, refer to *12. I/O Remote Settings*.

Connector	Standard
I/O Connector (Controller side)	D-sub 50 male pin Screwlock #4 - 40

* The I/O connector, I/O cable, terminal block, and I/O cable kit are offered as options.

* I/O connector is included with shipment.

12. I/O Remote Settings

This section describes the functions and timings of input and output signals.

The remote functions may be assigned to your standard I/O board(s), expansion I/O board(s), or fieldbus I/O board(s) to enhance robot system control - either from an operational unit of your choice or a sequencer.

The remote function is initially assigned to the input 0 to 7 and output 0 to 8.

To accept external remote inputs, assign the remote function and the control device is remote.

The user defines the I/O number that a remote function is assigned to using software configuration.

For details about communication with external equipment, refer to *Epson RC+ User's Guide - Remote Control*.



CAUTION

- When using remote I/O, always make sure of the followings. Using the robot system under unsatisfactory conditions may cause malfunction of the system and/or safety problems.
 - This signal is not safe signal. Do not use this for as a safety function.
 - Assign remote functions to inputs/outputs correctly and wire correctly when setting up remote I/O signals.
 - Make sure that the functions correspond to the correct input/output signals before turning ON the system.
 - When verifying the robot system operation, prepare for failures with initial settings or wiring. If the Manipulator functions unusually by the failures with initial settings or wiring, press the Emergency Stop switch immediately to stop the Manipulator.

NOTE



Remote function is available when virtual I/O is enabled.

When you set up a remote I/O signal, please either keep a written record of the settings or store the data in a file for later reference.

When you set up a fieldbus I/O signal to the remote function, response depends on the baud rate of the fieldbus. For details of fieldbus response, refer to the following manual:

Robot Controller option Fieldbus I/O

12.1 I/O Signal Description

The remote function is initially assigned to the input 0 to 7 and output 0 to 8.
 To change the function assignment from the initial setting, use Epson RC+.
 To use all signals, you will need to add Expansion I/O or Fieldbus I/O board(s).

12.1.1 Remote Input Signals

Remote inputs are used to control the Manipulators and start programs. Certain conditions must be met before inputs are enabled, as shown in the table below.

To accept external remote inputs, assign the remote function and set remote to the control device. When external remote input is available, “AutoMode output” turns ON.

Except “SelProg”, the signals execute each function when the signal starts in input acceptance condition. The function executes automatically. Therefore, no special programming is needed.

NOTE  When an error occurs, you must execute a “Reset” to clear the error condition before any other remote input commands can be executed. Use the “Error output” and “Reset input” to monitor the error status and clear error conditions from the remote device.

NOTE  If remote input commands do not meet the input acceptance condition, a CmdError signal outputs. The CmdError signal is not set to remote I/O output signal by default. When you use the remote function, set the CmdError signal to the remote I/O output signal.

Name	Default	Description	Input Acceptance Condition (*1)
Start	0	Execute function selected at SelProg. (*2) (*13)	Ready output ON Error output OFF EStopOn output OFF SafeguardOn output OFF EStopOff output ON Pause input OFF Stop input OFF
SelProg1	1	Specify the executing Main function number. (*2)	
SelProg2	2		
SelProg4	3		
SelProg8	Not Set		
SelProg16	Not Set		
SelProg32	Not Set		
Stop	4	All tasks and commands are stopped.	
Pause	5	All tasks are paused. (*3)	Running output ON
Continue	6	Continue the paused task.	Paused output ON Pause input OFF Stop input OFF
Reset	7	Reset emergency stop and error. (*4)	Ready output ON
Shutdown	Not Set	Terminates the system.	

Name	Default	Description	Input Acceptance Condition (*1)
ForcePowerLow	Not Set	Operates as the forced low power function. The robot is operated in the low power mode. Power High control from the command is not accepted. Executes the following according to the Controller preferences. Stops or temporarily stops all the tasks and commands. (*12)	Any time This input is acceptable even AutoMode output is OFF.
SelRobot	Not Set	Changes the output condition of MotorsOn, AtHome, PowerHigh, and MCalReqd. (*9)	
SelRobot1 SelRobot2 SelRobot4 SelRobot8 SelRobot16	Not Set	Specify the number of robot which executes a command. (*5)	
SetMotorOn	Not Set	Turn ON robot motors. (*5) (*6)	Ready output ON EStopOn output OFF SafeguardOn output OFF EStopOff output ON SetMotorOff input OFF
SetMotorOff	Not Set	Turn OFF robot motors. (*5)	Ready output ON
SetPowerHigh	Not Set	Set the robot power mode to High (*5)	Ready output ON EStopOn output OFF SafeguardOn output OFF EStopOff output ON SetPowerLow input OFF
SetPowerLow	Not Set	Set the robot power mode to Low. (*5)	Ready output ON
Home	Not Set	Move the Robot Arm to the home position defined by the user.	Ready output ON Error output OFF EStopOn output OFF SafeguardOn output OFF EStopOff output ON MotorsOn output ON Pause input OFF Stop input OFF
MCal	Not Set	Execute MCal (*5) (*7)	Ready output ON Error output OFF EStopOn output OFF SafeguardOn output OFF EStopOff output ON MotorsOn output ON Pause input OFF Stop input OFF
Recover	Not Set	After the safeguard is closed, recover to the position where the safeguard is open.	Paused output ON Error output OFF EStopOn output OFF SafeguardOn output OFF EStopOff output ON RecoverReqd output ON Pause input OFF Stop input OFF

Name	Default	Description	Input Acceptance Condition (*1)
ResetAlarm	Not Set	Cancel the alarm (*11)	
SelAlarm1 SelAlarm2 SelAlarm4 SelAlarm8	Not Set	Specify the alarm number to cancel (*10)	
ALIVE	Not Set	Input signal for alive monitoring of the Controller. Same signal as the input will be output to ALIVE output. The master equipment can perform alive monitoring of the Controller by switching the input periodically and checking the output signal.	

(*1) “AutoMode output” ON is omitted from the table. This is an input acceptance condition for all functions.

(*2) “Start input” executes Function specified by the following six bits: SelProg 1, 2, 4, 8, 16, and 32.

Function	SelProg1	SelProg2	SelProg4	SelProg8	SelProg16	SelProg32
Main	0	0	0	0	0	0
Main1	1	0	0	0	0	0
Main2	0	1	0	0	0	0
Main3	1	1	0	0	0	0
⋮						
Main60	0	0	1	1	1	1
Main61	1	0	1	1	1	1
Main62	0	1	1	1	1	1
Main63	1	1	1	1	1	1

0=OFF, 1=ON

(*3) “NoPause task” and “NoEmgAbort task” do not pause.

For details, refer to Epson RC+ *Online Help* or *Pause* in *SPEL+ Language Reference*.

(*4) Turns OFF the I/O output and initializes the robot parameter.

For details, refer to Epson RC+ *Online Help* or *Reset* in *SPEL+ Language Reference*.

(*5) When multiple robots are connected to the controller, the values specified by “SelRobot1, 2, 4, 8, and 16” correspond to the robot numbers.

Robot number	SelRobot1	SelRobot2	SelRobot4	SelRobot8	SelRobot16
0(All)	0	0	0	0	0
1	1	0	0	0	0
2	0	1	0	0	0
3	1	1	0	0	0
⋮					
13	1	0	1	1	0
14	0	1	1	1	0
15	1	1	1	1	0
16	0	0	0	0	1

0=OFF, 1=ON

(*6) Initializes the robot parameter.

For details, refer to Epson RC+ *Online Help* or *Motor* in *SPEL+ Language Reference*.

(*7) For details, refer to Epson RC+ *Online Help* or *MCal* in *SPEL+ Language Reference*.

(*8) This is for experienced users only. Make sure that you fully understand the input specification before using.

CmdRunning output and CmdError output will not change for this input.

“NoEmgAbort task” will not stop by this input.

When the input changes from ON to OFF, all tasks and commands will stop.

(*9) This function changes the output condition of MotorsOn, AtHome, PowerHigh, and MCalReqd.

By setting this signal with the condition selected using SelRobot1 - SelRobot16, you can switch the output condition.

Once you select the condition, it will be kept until you change it or turn OFF / restart the Controller.

All Manipulators are selected as default.

(*10) The values specified by “SelAlarm1, 2, 4, and 8” correspond to the alarm numbers.

Alarm #	Target	SelAlarm1	SelAlarm2	SelAlarm4	SelAlarm8
1	Controller battery	1	0	0	0
2	-	0	1	0	0
3	Grease of the Manipulator	1	1	0	0
4	-	0	0	1	0
5	-	1	0	1	0
6	-	0	1	1	0
7	-	1	1	1	0
8	-	0	0	0	1
9	-	1	0	0	1

0=OFF, 1=ON

For the parts subject to grease up, refer to the Manipulator manual.

(*11) The specified alarm can be canceled by selecting the conditions using SelAlarm1-SelAlarm8 and setting this signal.

(*12) Operation of all tasks and commands, power mode of the robot, and PowerHigh command are executed by the setting value of the controller preferences.

Preferences (1): “Motor power low when ForcePowerLow signal OFF”

Preferences (2): “ForcePowerLow signal change pauses all tasks”

For details of the Controller preferences, refer to *Epson RC+ User’s Guide*

[Setup]-[System Configuration]-[Controller]-[Preferences] in [System Configuration] Command (Setup Menu).

Preferences (1)	Preferences (2)	ForcePowerLow	All tasks and commands	Power mode	PowerHigh
0	0	1→0	Stop	Low only	Accept
0	0	0→1	Stop	Low only	Not accept
0	1	1→0	Continue	High/Low	Accept
0	1	0→1	Temp. stop	Low only	Not accept
1	0	1→0	Stop	Low only	Not accept
1	0	0→1	Stop	Low only	Accept
1	1	1→0	Temp. stop	Low only	Not accept
1	1	0→1	Continue	High/Low	Accept

(*13) Do not execute the Restart command of the SPEL program and the Start signal of the remote input at the same time. Errors may occur when the programs are executed at the same time.

12.1.2 Remote Output Signals

Remote outputs provide status for the Manipulator and Controller.

Remote outputs provide the assigned function using with any control device. The outputs execute automatically. Therefore, no special programming is needed.

Name	Initial	Description
Ready	0	Turns ON when the Controller startup completes and no task is running.
Running	1	Turns ON when task is running. However, turns OFF when “Paused output” is ON.
Paused	2	Turns ON when pause task exists.
Error	3	Turns ON when an error occurs. Use “Reset input” to recover from the error. (*13)
EStopOn	Not set	Turns OFF other than at Emergency Stop. Turns ON at Emergency Stop. Turns OFF at controller power OFF (*11)
SafeguardOn	5	Turns ON when the safeguard is open.
SError	6	Turns ON when critical error occurs. When a critical error occurs, “Reset input” does not function. Reboot the Controller to recover. (*13)
Warning	7	Turns ON when warning occurs. The task runs as normal with the warning. However, be sure to eliminate the cause of the warning as soon as possible. (*13)
EStopOff	8	Turns ON other than at Emergency Stop. Turns OFF at Emergency Stop. Turns ON at controller power OFF
MotorsOn	Not set	Turns ON when the robot motor is ON. (*5)
AtHome	Not set	Turns ON when the robot is in the home position. (*5)
PowerHigh	Not set	Turns ON when the robot’s power mode is High. (*5)
MCalReqd	Not set	Turns ON when the robot hasn’t executed MCal. (*5)
RecoverReqd	Not set	Turns ON when at least one robot is waiting for Recover after the safeguard is closed.
RecoverInCycle	Not set	Turns ON when at least one robot is executing Recover.
WaitingRC	Not set	Turns ON when the controller waits for RC+ to connect.
CmdRunning	Not set	Turns ON when an input command is executing.
CmdError	Not set	Turns ON when an input command cannot be accepted.
CurrProg1 CurrProg2 CurrProg4 CurrProg8 CurrProg16 CurrProg32	Not set	Indicates the running or the last main function number (*1)
AutoMode	Not set	Turns ON in remote input acceptable status. (*2)
TeachMode	Not set	Turns ON in TEACH mode.
TestMode	Not set	Turns ON in TEST mode.
EnableOn	Not set	Turns ON when enable switch is ON.
ErrorCode1 ⋮ ErrorCode8192	Not set	Indicates the error number.
InsideBox1 ⋮ InsideBox15	Not set	Turns ON when the robot is in the approach check area. (*3)

Name	Initial	Description
InsidePlane1 ⋮ InsidePlane15	Not set	Turns ON when the robot is in the approach check plane. (*4)
Alarm	Not set	Turns ON when any of the alarms is occurring. (*9)
Alarm1	Not set	Turns ON when a battery alarm of the Controller is occurring. (*12)
Alarm2	Not set	Turns ON when a battery alarm of the robot connected to CU is occurring. (*12)
Alarm3	Not set	Turns ON when a grease alarm of the robot connected to CU is occurring. (*10) (*12)
Alarm4	Not set	Turns ON when a battery alarm of the robot connected to DU1 is occurring. (*12)
Alarm5	Not set	Turns ON when a grease alarm of the robot connected to DU1 is occurring. (*10) (*12)
Alarm6	Not set	Turns ON when a battery alarm of the robot connected to DU2 is occurring. (*12)
Alarm7	Not set	Turns ON when a grease alarm of the robot connected to DU2 is occurring. (*10) (*12)
Alarm8	Not set	Turns ON when a battery alarm of the robot connected to DU3 is occurring. (*12)
Alarm9	Not set	Turns ON when a grease alarm of the robot connected to DU3 is occurring. (*10) (*12)
PositionX	Not set	Outputs current X coordinate in the World coordinate system (*6) (*7)
PositionY	Not set	Outputs current Y coordinate in the World coordinate system (*6) (*7)
PositionZ	Not set	Outputs current Z coordinate in the World coordinate system (*6) (*7)
PositionU	Not set	Outputs current U coordinate in the World coordinate system (*6) (*7)
PositionV	Not set	Outputs current V coordinate in the World coordinate system (*6) (*7)
PositionW	Not set	Outputs current W coordinate in the World coordinate system (*6) (*7)
Torque1	Not set	Outputs the current torque value of Joint #1 (*6) (*7)
Torque2	Not set	Outputs the current torque value of Joint #2 (*6) (*7)
Torque3	Not set	Outputs the current torque value of Joint #3 (*6) (*7)
Torque4	Not set	Outputs the current torque value of Joint #4 (*6) (*7)
Torque5	Not set	Outputs the current torque value of Joint #5 (*6) (*7)
Torque6	Not set	Outputs the current torque value of Joint #6 (*6) (*7)
CPU	Not set	Outputs the CPU load factor of the user program (*8)
ESTOP	Not set	Outputs how many times emergency stops have been executed.
ALIVE	Not set	Output signal for alive monitoring of the Controller. The signal input by ALIVE input will be output. The master equipment can perform alive monitoring of the Controller by switching the input periodically and checking the output signal.
ForceControlOn	Not set	Turns ON when the manipulator operating force control function. (*5)
ExtCmdGet	Not set	For extended remote I/O command. For details, refer to the following manual. <i>Remote Control Reference - Remote I/O to Be Used</i>
ExtRespSet	Not set	
ExtCmdResult	Not set	
ExtError	Not set	
ExtResp_0-15	Not set	
ExtResp_16-31	Not set	
ExtResp_32-47	Not set	
ExtResp_48-63	Not set	
ExtResp_64-79	Not set	
ExtResp_80-95	Not set	
ExtResp_96-111	Not set	
ExtResp_112-127	Not set	

(*1) Outputs the current or the last function number of CurrProg1, 2, 4, 8, 16, or 32.

Function	CurrProg1	CurrProg2	CurrProg4	CurrProg8	CurrProg16	CurrProg32
Main	0	0	0	0	0	0
Main1	1	0	0	0	0	0
Main2	0	1	0	0	0	0
Main3	1	1	0	0	0	0
				⋮		
Main60	0	0	1	1	1	1
Main61	1	0	1	1	1	1
Main62	0	1	1	1	1	1
Main63	1	1	1	1	1	1

0=OFF, 1=ON

(*2) Remote function is available in the followings conditions.

- The setting is Auto mode and the control device is remote.
- The setting is Program mode and Remote I/O is enabled.

(*3) For details, refer to EPSON RC+ 7.0 *Online Help* or *Box* in *SPEL+ Language Reference*.

(*4) For details, refer to EPSON RC+ 7.0 *Online Help* or *Plane* in *SPEL+ Language Reference*.

(*5) Manipulator status is output as follows, according to the condition selected in SelRobot.

Wait at least 40 ms before inputting the signal after changing the condition in SelRobot.

Name	(SelRobot1- SelRobot16) condition when inputting SelRobot	
	0: All robots are selected	1 - 16: Particular robot number is selected
MotorsOn	Turns ON when at least one motor is ON.	Turns ON when the motor of the selected robot is ON.
AtHome	Turns ON when all robots are in the home position.	Turns ON when the selected robot is in the home position.
PowerHigh	Turns ON when at least one robot's power mode is High.	Turns ON when the selected robot's power mode is High.
MCalReqd	Turns ON when at least one robot hasn't executed MCal	Turns ON when the selected robot hasn't executed MCal.

(*6) Outputs information of the selected robot when SelRobot1, SelRobot2, SelRobot4, SelRobot8, and SelRobot16 are set. If not, information of Robot 1 will be output.

(*7) Outputs information in Real format.

(*8) Outputs the total load factor of the user created tasks. For details on the CPU load factor, refer to the task manager.

(*9) The signal turns ON when the alarm occurs either in the Controller alarm information or the robot alarm information.

(*10) For details about the target of grease up, refer to each manipulator manuals.

(*11) It is not recommended that EStopOn does not match the output with emergency stop state and controller off state. To output the state of emergency stop, assign EStopOff.

(*12) The occurrence of battery alarm and grease alarm is monitored every 5 minutes. The alarm occurrence and output timing of the controller are different. It may be output up to 5 minutes after the controller alarm occurs.

“Alarm” will on when battery alarm or grease alarm of Controller or Manipulator occurs with “Robot maintenance” enabled. For details of Robot maintenance, refer to “Alarm” section.

(*13) Following shows status number/error number of output (Error, SError, Warning).

Name	Error Number
Error	1000 to 8000s
SError	9000s
Warning	410 to 900s

For more information of status number/error number, refer to following manuals.

“Status Code / Error Code List”

12.2 Timing Specifications

12.2.1 Design Notes for Remote Input Signals

The following charts indicate the timing sequences for the primary operations of the Controller.

The indicated time lapses (time durations) should be referred to only as reference values since the actual timing values vary depending on the number of tasks running, as well as CPU speed of the Controller. Check carefully and refer to the following charts for the timing interrelation when you enter an input signal.

During system design, make sure that you actuate only one remote input operation at a time, otherwise an error will occur.

The pulse width of an input signal must be 25 or more milliseconds to be detected.

12.2.2 Timing Diagram for Operation Execution Sequence

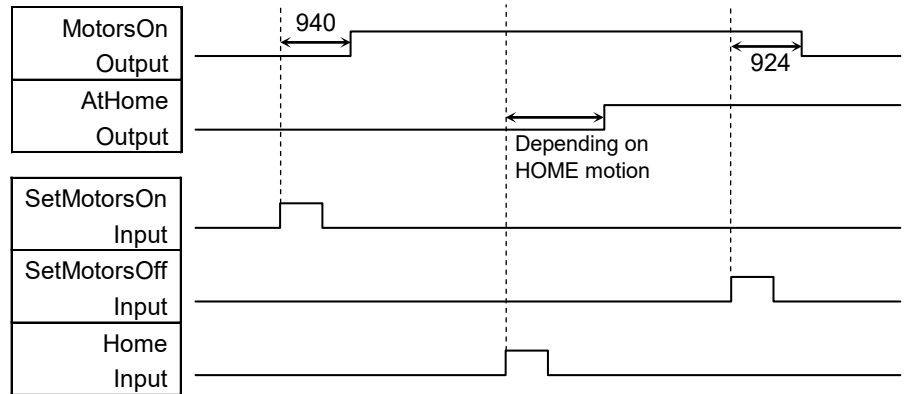

[Unit: msec]

12.2.3 Timing Diagram for Program Execution Sequence

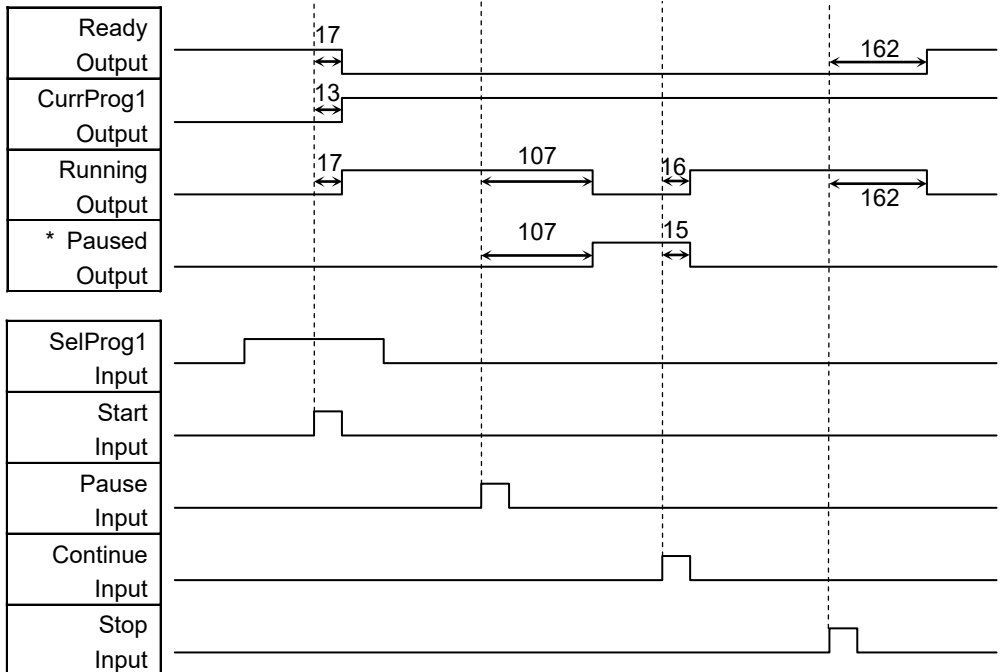

* The duration varies depending on the Quick Pause (QP) setting and the program's operating status at the time of Pause input [Unit: msec]

12.2.4 Timing Diagram for Safety Door Input Sequence

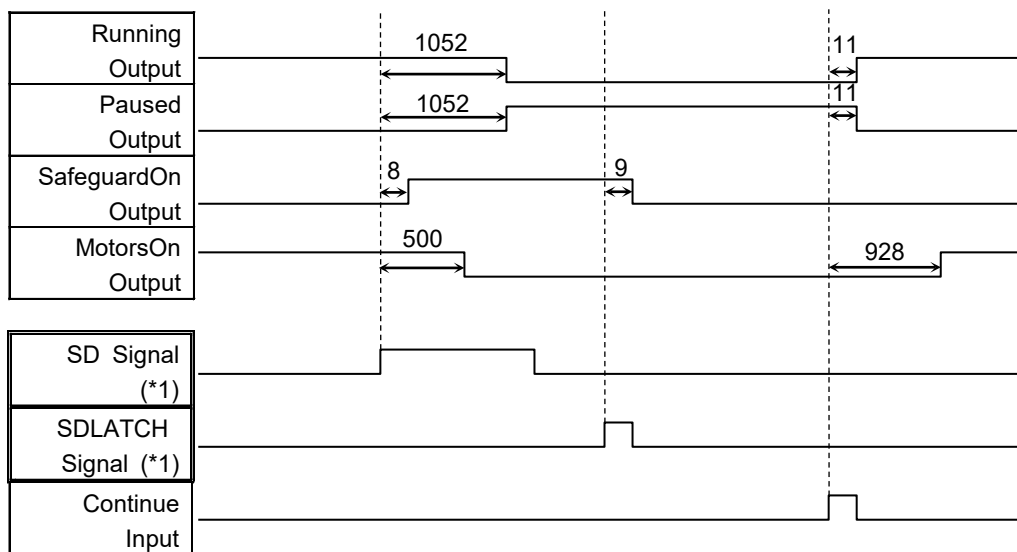

[Unit: msec]

(*1) A logical signal to explain the timing of internal processing of the controller.

For details about input signals name and operating conditions, refer to the 9.3 Pin Assignments.

12.2.5 Timing Diagram for Emergency Stop Sequence

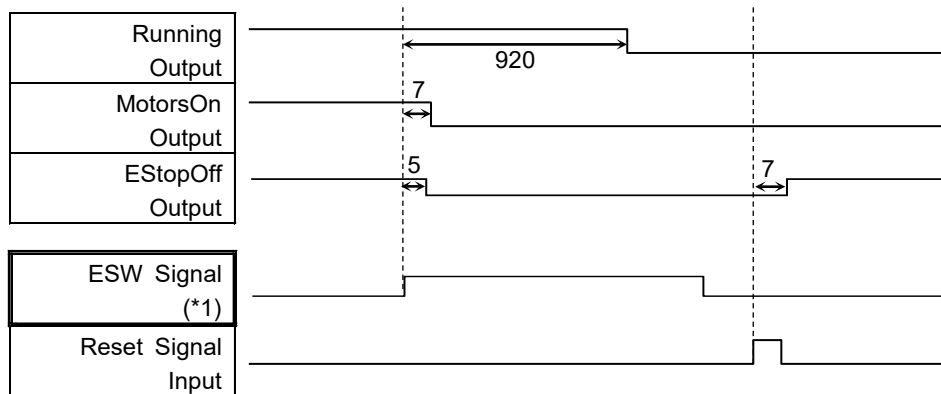

[Unit: msec]

(*1) A logical signal to explain the timing of internal processing of the controller.

For details about input signals name and operating conditions, refer to the 9.3 Pin Assignments.

13. R-I/O Connector

The R-I/O connector is for connecting the input signals of the real time I/O function.

	Pins	Bit number
Input	2	24, 25

By inputting trigger signals to the R-I/O, you can keep and get the operating robot position when trigger is detected. If you use this function with Vision, you can create an application of parts pickup, alignment, and assembly by robots without stopping.

For details, refer to *Epson RC+ Users Guide - Real time I/O*.

13.1 Input Circuit

Input Voltage Range : +24 V ±10%

Input Current : 10 mA (TYP) at +24 V input

The following two types of wiring are available in the input circuit for Control Unit.

Typical Input Circuit Application 1

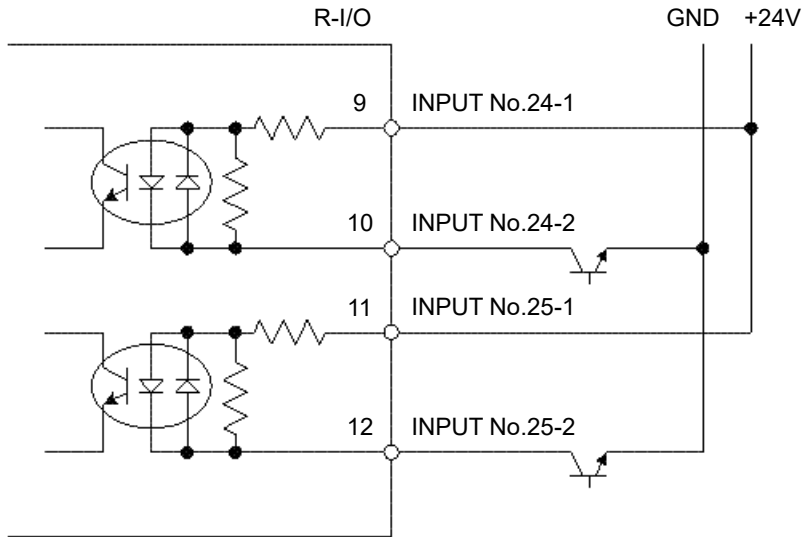

Typical Input Circuit Application 2

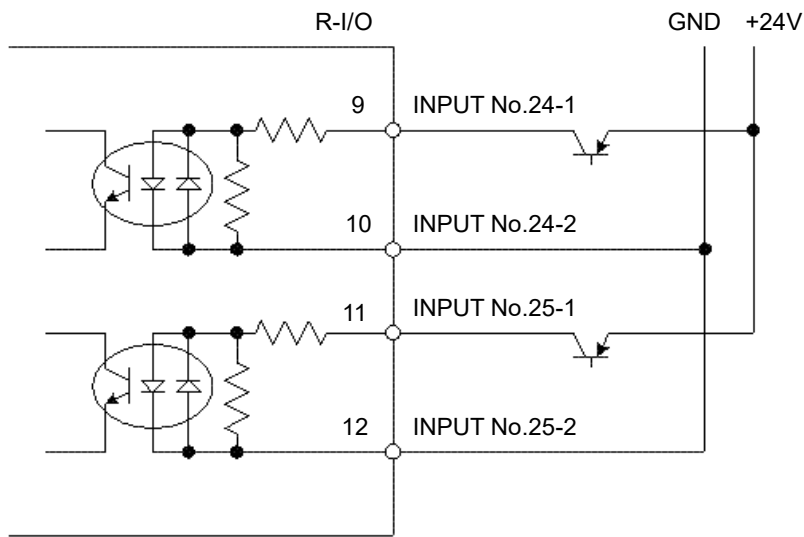

13.2 Pin Assignments

 CAUTION	<ul style="list-style-type: none"> ■ When using R-I/O connector, be careful of the following points. If you use the R-I/O connector without meeting the necessary conditions, it may cause the system failure and/or safety problems. <ul style="list-style-type: none"> - Use a shielded cable and route the cables as far from the surrounding noise sources as possible. For details, refer to <i>3.5 Noise Countermeasures</i>. - Make sure to check the cable routing before turning ON the power supply.
--	--

Pin No.	Signal Name
9	INPUT No24-1
10	INPUT No24-2
11	INPUT No25-1
12	INPUT No25-2
1 to 8, 13 to 15*	Not Used

* For the pins 1 to 8 and 13 to 15, do not connect anything.

Connector	Standard
R-I/O Connector (Controller side)	D-sub 15 male pin Screwlock #4 - 40

14. Option Slots

14.1 About Option Slots

Use the Option Slot to install the optional boards.

Up to four option boards can be installed in the Controller. The types of the option boards are as follows:

- 14.2 Expansion I/O Board
- 14.3 Fieldbus I/O Board
- 14.4 RS-232C Board
- 14.5 PG Board
- 14.6 Analog I/O Board
- 14.7 Force Sensor I/F Board
- 14.8 EUROMAP67 Board

14.2 Expansion I/O Board

14.2.1 Expansion I/O Board

Each additional expansion I/O board provides 24 inputs and 16 outputs.

You can install up to four expansion I/O boards in the Controller.

The input and output bit numbers are assigned as follows. (Bit number is assigned from CN1.)

Input Bit #	Output Bit #	Applicable Hardware
0 to 23	0 to 15	STANDARD I/O
64 to 87	64 to 79	The 1 st Expansion I/O board
96 to 119	96 to 111	The 2 nd Expansion I/O board
128 to 151	128 to 143	The 3 rd Expansion I/O board
160 to 183	160 to 175	The 4 th Expansion I/O board

14.2.2 Board Configuration (Expansion I/O Board)

Board Appearance

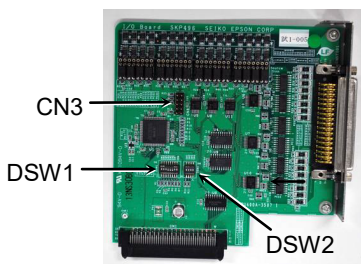

Switch and Jumper Configuration

Setup the DSW1 and DSW2. CN3 is all open.

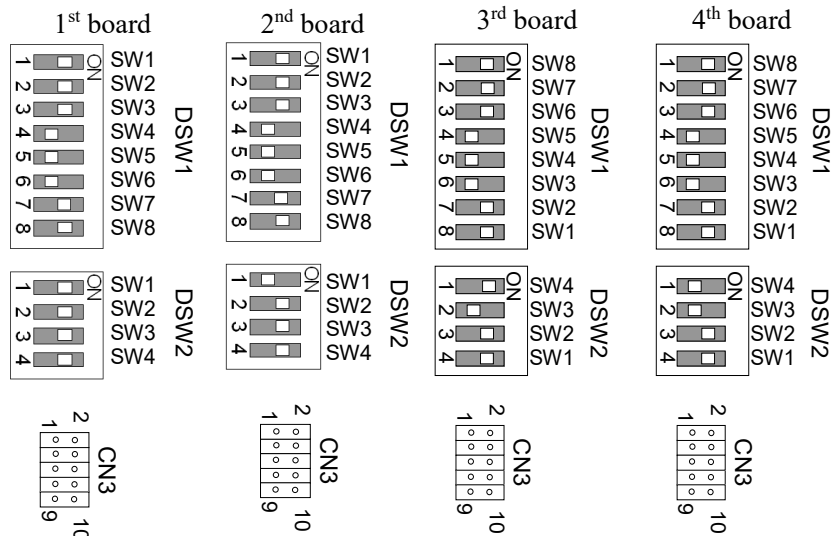

14.2.3 Confirmation with Epson RC+ (Expansion I/O Board)

When an expansion I/O board is mounted to the option unit, the Controller software automatically identifies the expansion I/O board. Therefore, no software configuration is needed.

Correct identification can be confirmed from Epson RC+.

- (1) Select the Epson RC+ menu-[Setup]-[System Configuration] to display the [System Configuration] dialog.

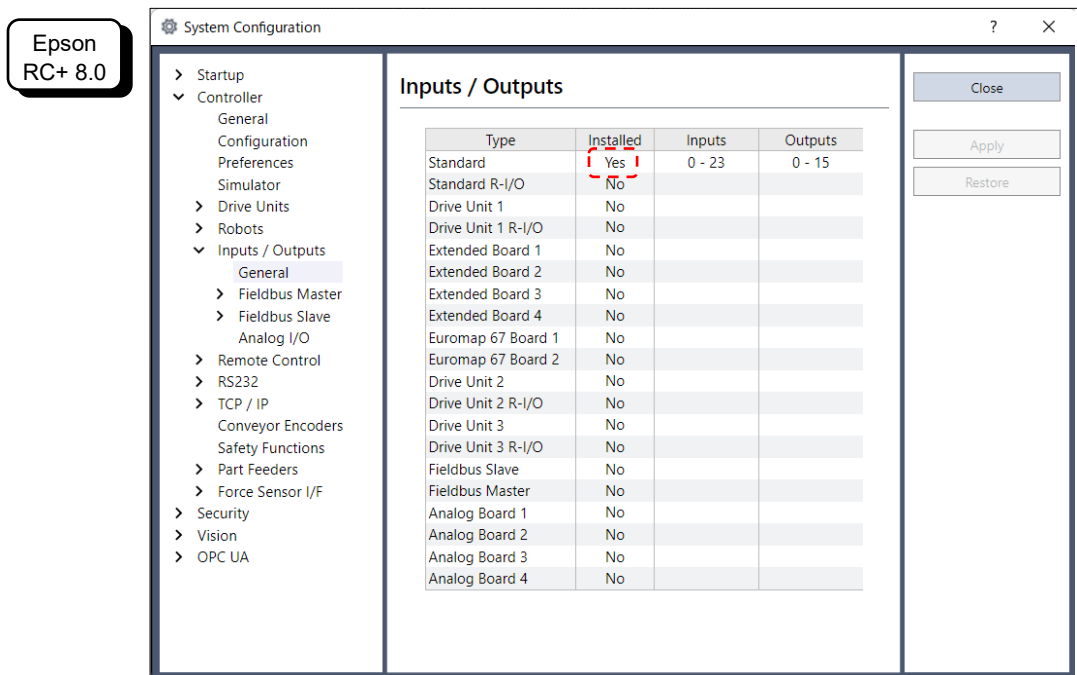
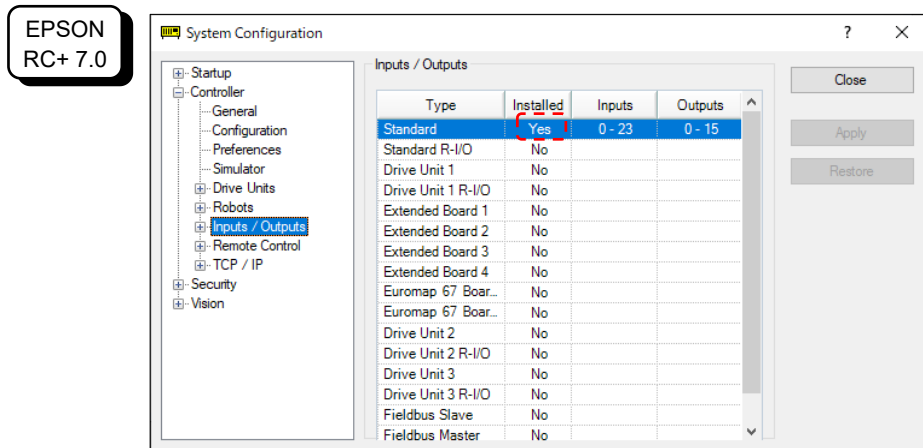

- (2) Select [Controller]-[Inputs / Outputs].
- (3) Make sure that “Yes” is displayed in the Installed column.
The expansion I/O board is identified by the Controller software. Corresponding Input and Output is available.

14.2.4 Input Circuit

Input Voltage Range : + 12 V to 24 V \pm 10%

ON Voltage : + 10.8 V (Min.)

OFF Voltage : + 5 V (Max.)

Input Current : 10 mA (TYP) at + 24 V input

Two types of wiring are available for use with the two-way photo coupler in the input circuit.

Protected Expansion I/O Board Typical Input Circuit Application 1

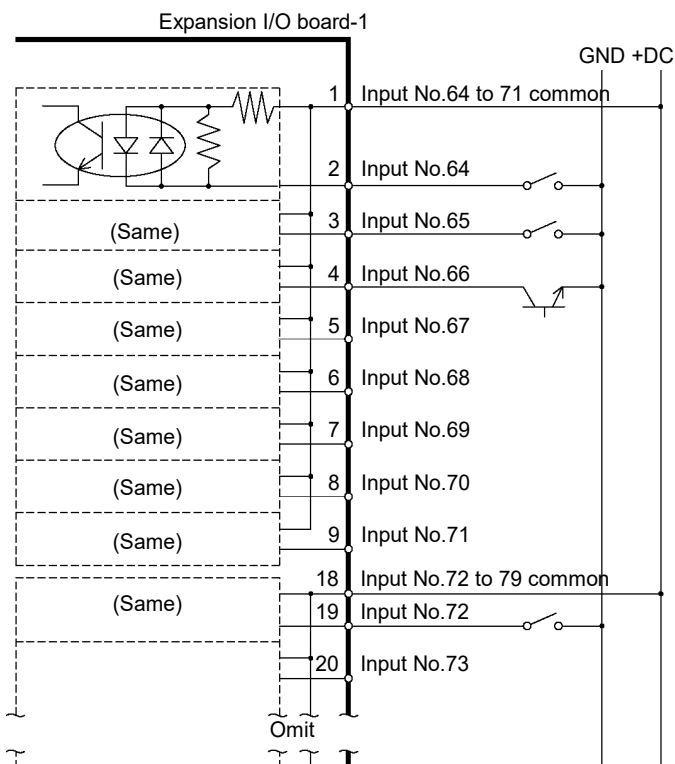

Protected Expansion I/O Board Typical Input Circuit Application 2

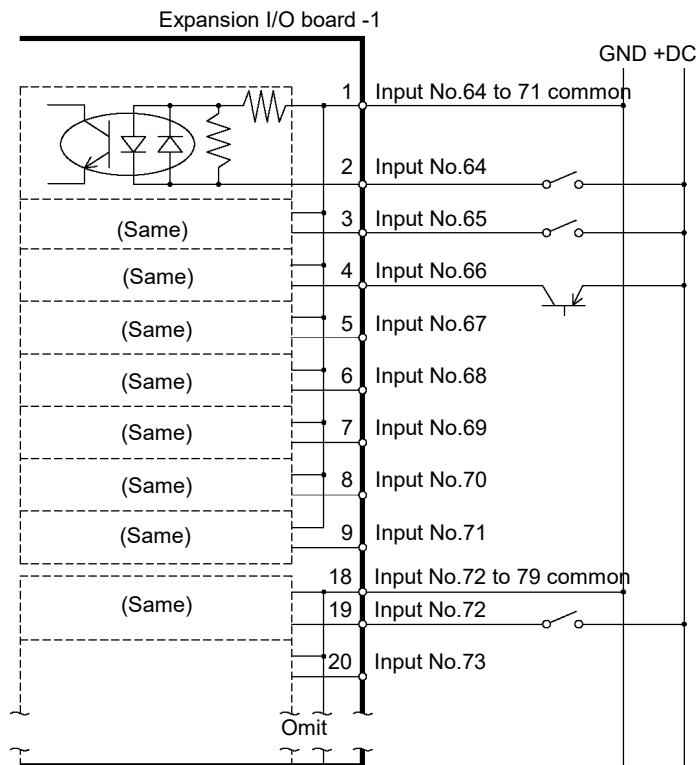

14.2.5 Output Circuit

Rated Output Voltage : +12 V to 24 V ±10%
 Maximum Output Current : TYP 100 mA/1 output
 Output Driver : Photo coupler



CAUTION

- The output circuit has two types: Sink type and Source type. The either type has been configured in the Controller before the shipment. Before routing the cables, make sure that the I/O output type of your Controller conforms to the external connection devices.
 If you route the cables with wrong output type, the parts on the board will be broken and the robot system won't operate normally.
- Use the wiring diagram of 2: *Source Type* for CE conformance. Be sure to wire correctly. Improper wiring may cause safety problems as it may make the Manipulator move unusually.
- Be sure to wire the output circuit properly because it has no protection circuitry for short-circuit and reverse-connection. Improper wiring may cause malfunction of the parts on the board and then improper function of the robot system.

Typical Output Circuit Application 1: Sink Type (NPN)

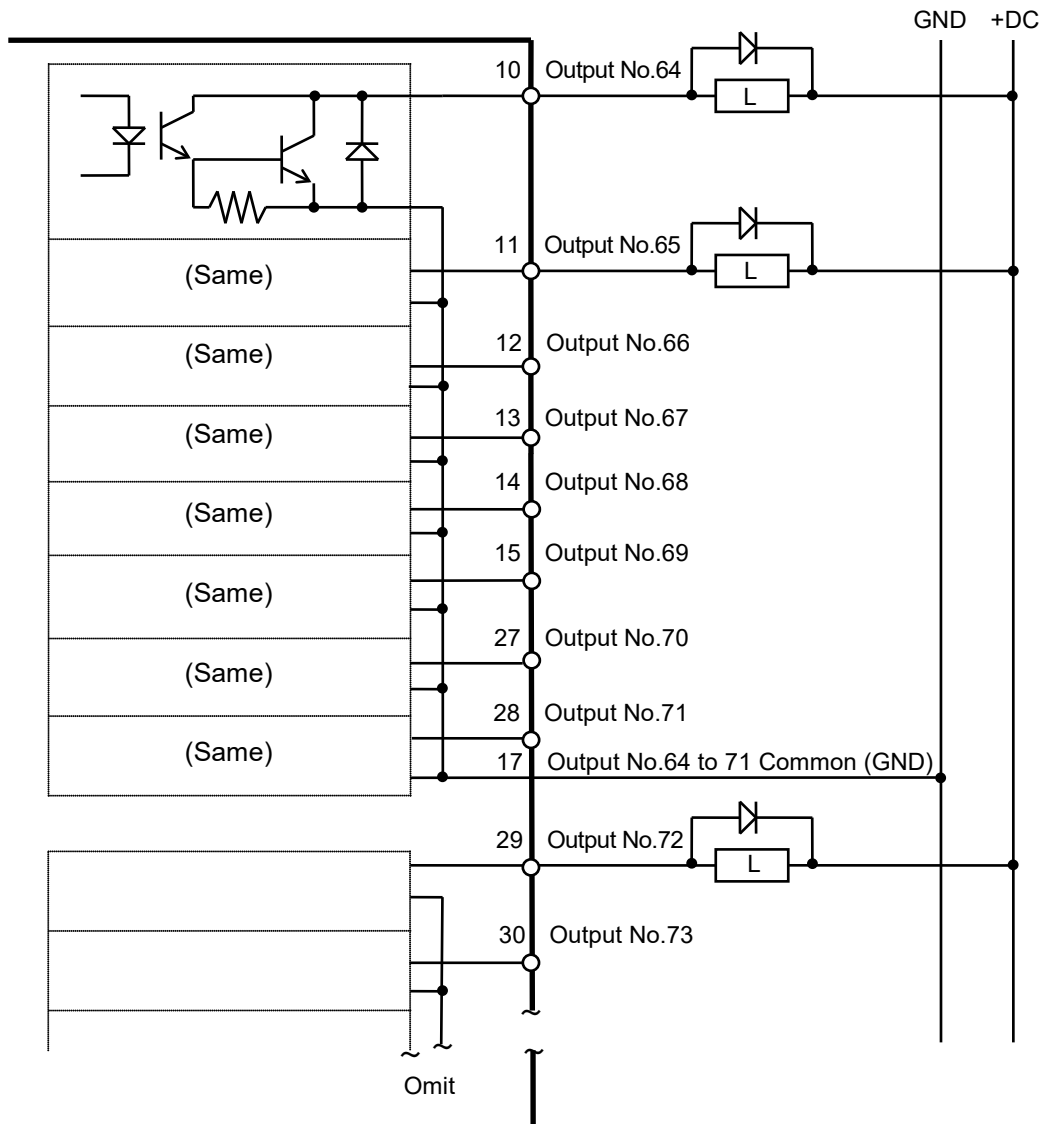

Typical Output Circuit Application 2: Source Type (PNP)

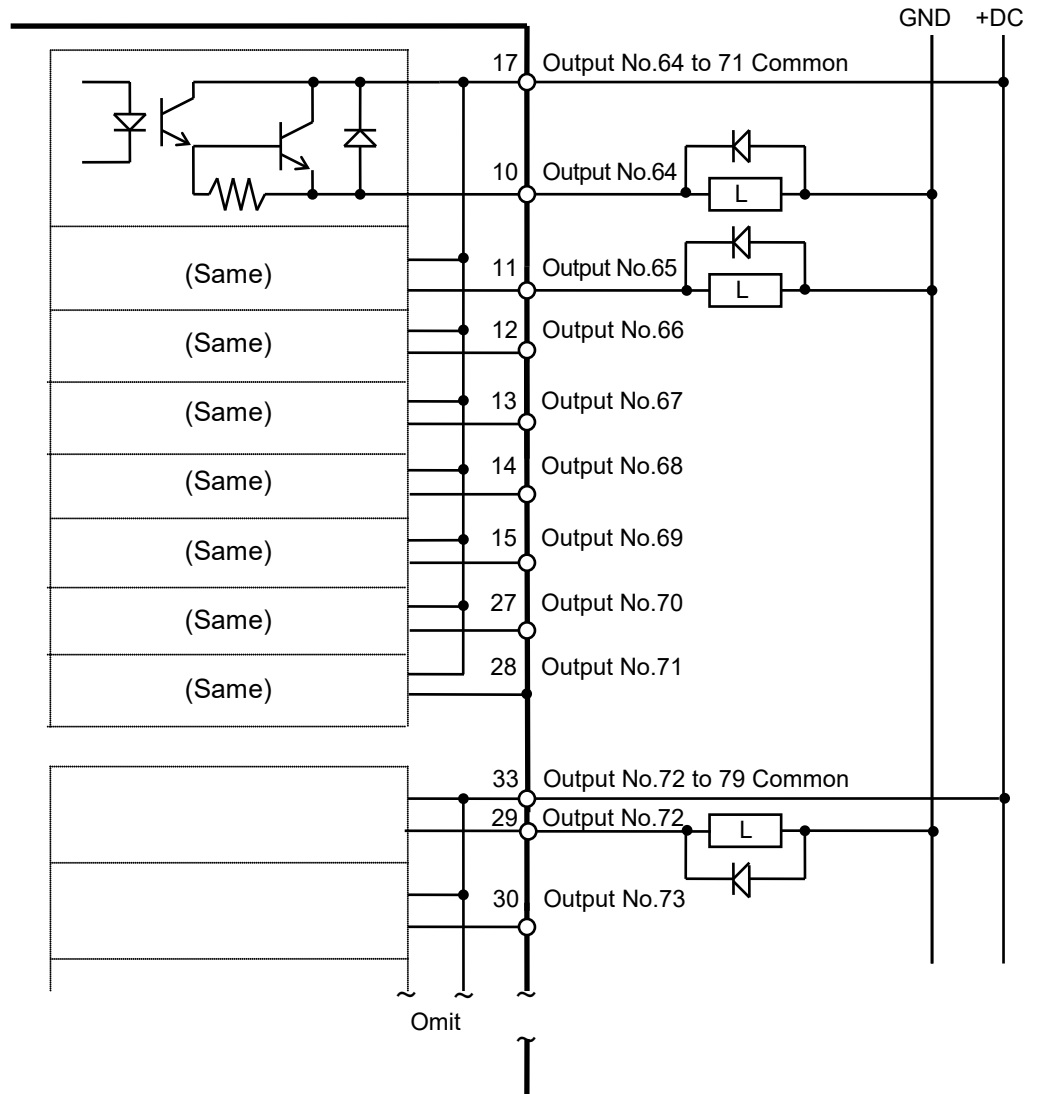

14.2.6 Pin Assignments (Expansion I/O Board)

Pin Assignment table of the 1st Expansion I/O board.

Connector 1 Pin Assignments

Pin No.	Signal Name	Pin No.	Signal Name	Pin No.	Signal Name
1	Input common No.64 to 71	18	Input common No.72 to 79	34	Input common No.80 to 87
2	Input No.64	19	Input No.72	35	Input No.80
3	Input No.65	20	Input No.73	36	Input No.81
4	Input No.66	21	Input No.74	37	Input No.82
5	Input No.67	22	Input No.75	38	Input No.83
6	Input No.68	23	Input No.76	39	Input No.84
7	Input No.69	24	Input No.77	40	Input No.85
8	Input No.70	25	Input No.78	41	Input No.86
9	Input No.71	26	Input No.79	42	Input No.87
10	Output No.64	27	Output No.70	43	Output No.75
11	Output No.65	28	Output No.71	44	Output No.76
12	Output No.66	29	Output No.72	45	Output No.77
13	Output No.67	30	Output No.73	46	Output No.78
14	Output No.68	31	Output No.74	47	Output No.79
15	Output No.69	32	Not Used	48	Not Used
16	Not Used	33	Output common No.72 to 79	49	Not Used
17	Output common No.64 to 71			50	Not Used

Connector	Standard
I/O Connector (Controller side)	D-sub 50 male pin Screwlock #4 - 40

* The I/O connector, I/O cable, terminal block, and I/O cable kit are offered as options.

* I/O connector is included with shipment.

Pin Assignment table of the 2nd Expansion I/O board.

Connector 1 Pin Assignments

Pin No.	Signal Name	Pin No.	Signal Name	Pin No.	Signal Name
1	Input common No.96 to 103	18	Input common No.104 to 111	34	Input common No.112 to 119
2	Input No.96	19	Input No.104	35	Input No.112
3	Input No.97	20	Input No.105	36	Input No.113
4	Input No.98	21	Input No.106	37	Input No.114
5	Input No.99	22	Input No.107	38	Input No.115
6	Input No.100	23	Input No.108	39	Input No.116
7	Input No.101	24	Input No.109	40	Input No.117
8	Input No.102	25	Input No.110	41	Input No.118
9	Input No.103	26	Input No.111	42	Input No.119
10	Output No.96	27	Output No.102	43	Output No.107
11	Output No.97	28	Output No.103	44	Output No.108
12	Output No.98	29	Output No.104	45	Output No.109
13	Output No.99	30	Output No.105	46	Output No.110
14	Output No.100	31	Output No.106	47	Output No.111
15	Output No.101	32	Not Used	48	Not Used
16	Not Used	33	Output common No.104 to 111	49	Not Used
17	Output common No.96 to 103			50	Not Used

Connector	Standard
I/O Connector (Controller side)	D-sub 50 male pin Screwlock #4 - 40

* The I/O connector, I/O cable, terminal block, and I/O cable kit are offered as options.

* I/O connector is included with shipment.

Pin Assignment table of the 3rd Expansion I/O board.

Connector 1 Pin Assignments

Pin No.	Signal Name	Pin No.	Signal Name	Pin No.	Signal Name
1	Input common No.128 to 135	18	Input common No.136 to 143	34	Input common No.144 to 151
2	Input No.128	19	Input No.136	35	Input No.144
3	Input No.129	20	Input No.137	36	Input No.145
4	Input No.130	21	Input No.138	37	Input No.146
5	Input No.131	22	Input No.139	38	Input No.147
6	Input No.132	23	Input No.140	39	Input No.148
7	Input No.133	24	Input No.141	40	Input No.149
8	Input No.134	25	Input No.142	41	Input No.150
9	Input No.135	26	Input No.143	42	Input No.151
10	Output No.128	27	Output No.134	43	Output No.139
11	Output No.129	28	Output No.135	44	Output No.140
12	Output No.130	29	Output No.136	45	Output No.141
13	Output No.131	30	Output No.137	46	Output No.142
14	Output No.132	31	Output No.138	47	Output No.143
15	Output No.133	32	Not Used	48	Not Used
16	Not Used	33	Output common No.136 to 143	49	Not Used
17	Output common No.128 to 135			50	Not Used

Connector	Standard
I/O Connector (Controller side)	D-sub 50 male pin Screwlock #4 - 40

* The I/O connector, I/O cable, terminal block, and I/O cable kit are offered as options.

* I/O connector is included with shipment.

Pin Assignment table of the 4th Expansion I/O board.

Connector 1 Pin Assignments

Pin No.	Signal Name	Pin No.	Signal Name	Pin No.	Signal Name
1	Input common No.160 to 167	18	Input common No.168 to 175	34	Input common No.176 to 183
2	Input No.160	19	Input No.168	35	Input No.176
3	Input No.161	20	Input No.169	36	Input No.177
4	Input No.162	21	Input No.170	37	Input No.178
5	Input No.163	22	Input No.171	38	Input No.179
6	Input No.164	23	Input No.172	39	Input No.180
7	Input No.165	24	Input No.173	40	Input No.181
8	Input No.166	25	Input No.174	41	Input No.182
9	Input No.167	26	Input No.175	42	Input No.183
10	Output No.160	27	Output No.166	43	Output No.171
11	Output No.161	28	Output No.167	44	Output No.172
12	Output No.162	29	Output No.168	45	Output No.173
13	Output No.163	30	Output No.169	46	Output No.174
14	Output No.164	31	Output No.170	47	Output No.175
15	Output No.165	32	Not Used	48	Not Used
16	Not Used	33	Output common No.168 to 175	49	Not Used
17	Output common No.160 to 167			50	Not Used

Connector	Standard
I/O Connector (Controller side)	D-sub 50 male pin Screwlock #4 - 40

* The I/O connector, I/O cable, terminal block, and I/O cable kit are offered as options.

* I/O connector is included with shipment.

14.3 Fieldbus I/O Board

Fieldbus I/O supports the following models.

- DeviceNet™
- PROFIBUS-DP
- PROFINET
- CC-LINK
- EtherNet/IP™
- EtherCAT®
- Modbus (This is not optional but a standard feature.)

Refer to the following manuals.

Robot Controller option Fieldbus I/O

Epson RC+ User's Guide - Fieldbus Slave I/O

14.4 RS-232C Board

14.4.1 About the RS-232C Board

One standard RS-232C port is not available with the Controller.

You need to mount the RS-232C board in the Option Slot to communicate with external equipment using two or more port RS-232C.

The RS-232C board accepts two ports expansion per board. A maximum of two boards/four ports expansion is available for RS-232C board.

When using the Force Sensor I/F board, a maximum of one board/two ports expansion is available for RS-232C board.

Port Number

Port numbers are assigned as follows.

Port No.	Supported hardware
#2, #3	First RS-232C board
#4, #5	Second RS-232C board

14.4.2 Board Setup (RS-232C)

Board Appearance

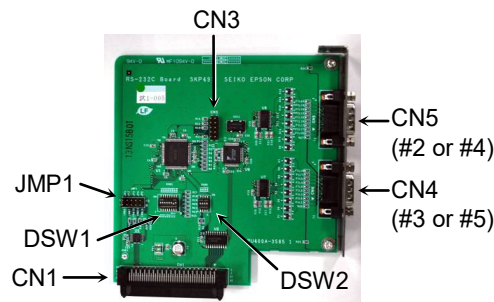

Switch and Jumper Configuration

Set DSW1, DSW2 and JMP1.

CN3 is all open.

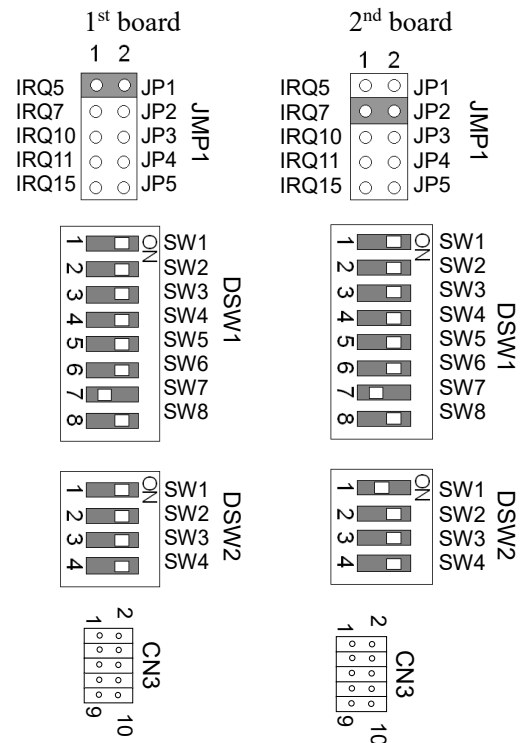

14.4.3 Confirmation with Epson RC+ (RS-232C)

When an RS-232C board is mounted in as option unit, the Controller software automatically identifies the RS-232C board. Therefore, no software configuration is needed. Correct identification can be confirmed from Epson RC+.

- (1) Select the Epson RC+ menu-[Setup]-[System Configuration] to display the [System Configuration] dialog.

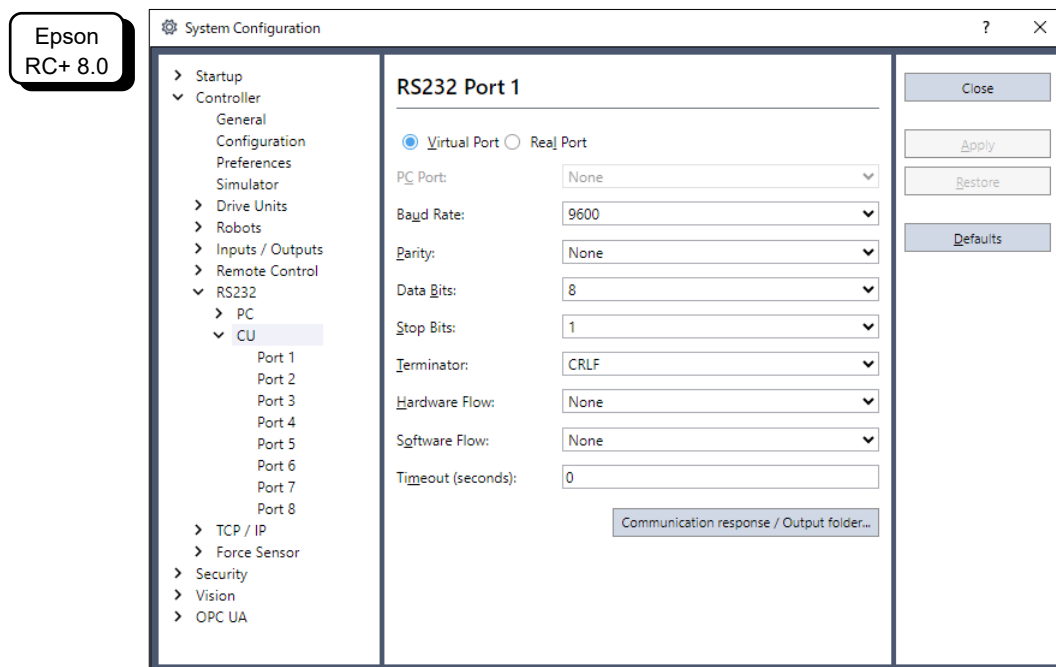
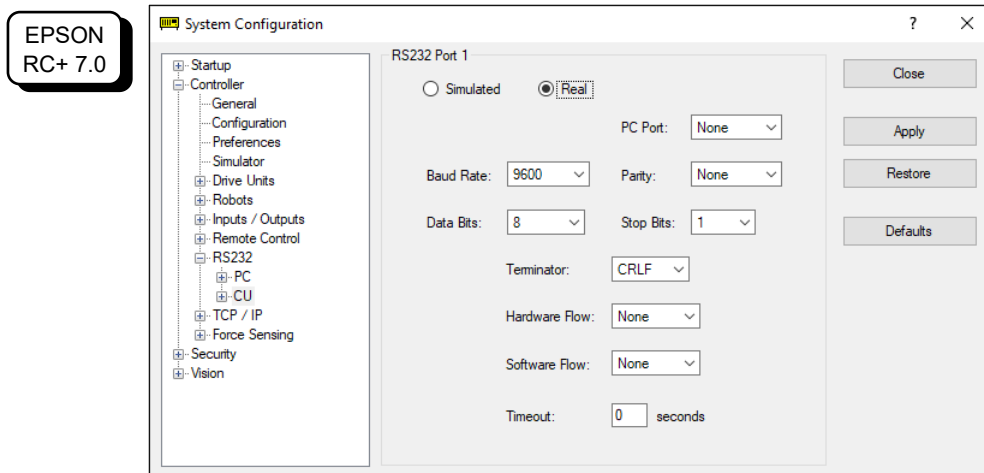

- (2) Select the [RS232]-[CU].

14.4.4 RS-232C Software Communication Setup (RS-232C)

Available communication settings are as follows.

Item	Specification
Baud Rates	110, 300, 600, 1200, 2400, 4800, 9600, 14400, 19200, 38400, 57600, 115200
Data bit length	7, 8
Stop bit length	1, 2
Parity	Odd, even, NA
Terminator	CR, LF, CRLF

Refer to *Epson RC+ Online Help* or *Users Guide - RS-232C Communications* for RS-232C communication from the Robot application.

14.4.5 Communication Cable (RS-232C)

Prepare a communication cable as described in this section.

Connector	Standard
RS-232C Connector (Controller side)	D-sub 9 male pin Screwlock #4 - 40

NOTE



Use twisted pair cable for shielded wire.

Clamp the shield to the hood for noise prevention.

Pin assign of the RS-232C connector is as follows.

Pin No	Signal	Function	Signal Direction
1	DCD	Data carrier detect	Input
2	RXD	Receive data	Input
3	TXD	Send data	Output
4	DTR	Terminal ready	Output
5	GND	Signal ground	-
6	DSR	Data set ready	Input
7	RTS	Request to send	Output
8	CTS	Clear to send	Input
9	RI	Ring indicator	Input

14.5 PG Board

The PG board has the following two types of usage. For details, refer to the related manuals.

When using as the conveyor encoder:

Refer to *Epson RC+ User's Guide - Conveyor Tracking*

When using as a PG motion system:

Refer to *Robot Controller option PG Motion System*

14.6 Analog I/O Board

14.6.1 About Analog I/O Board

Analog input/output function is available when mounting analog I/O board to the option slot. You can install a maximum of four analog I/O boards in the option slot.

Analog I/O Board (1CH): "DAC: 1ch" is available for one board.

Analog I/O Board (4CH): "DAC: 2ch, ADC: 2ch" is available for one board.

DAC: Analog signal output (voltage/current)

ADC: Analog signal input (voltage/current)

Connection Example of Analog I/O Board (4CH)

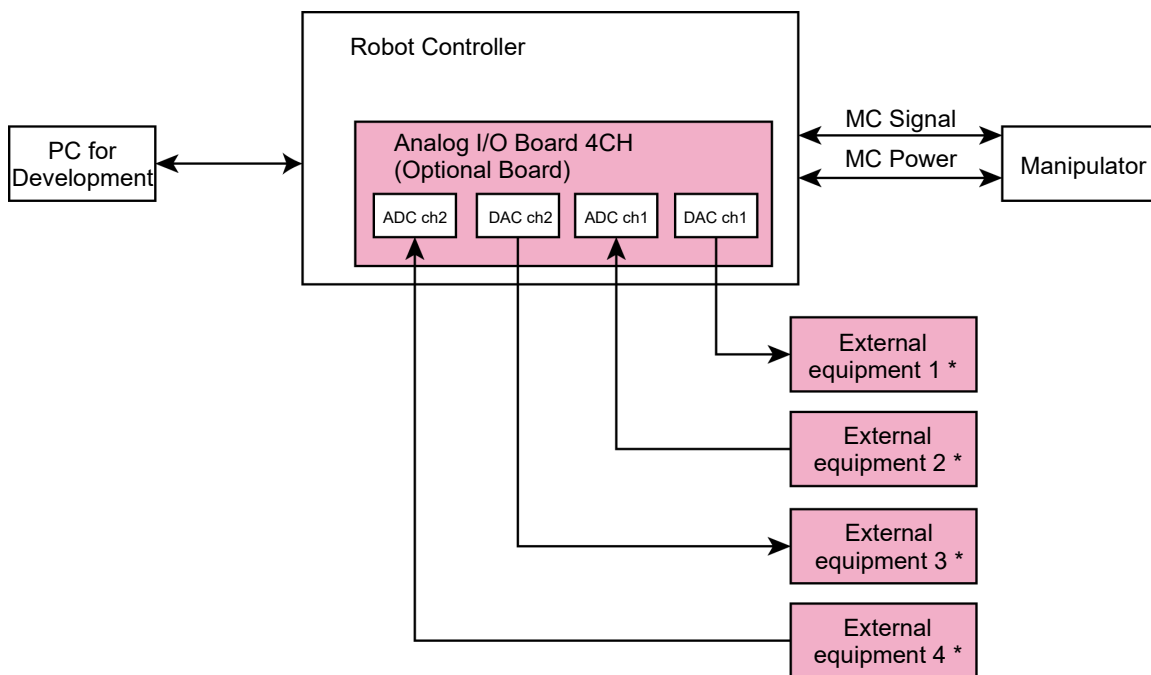

*: Voltage/Current Input

Overview of Analog I/O Board Circuit

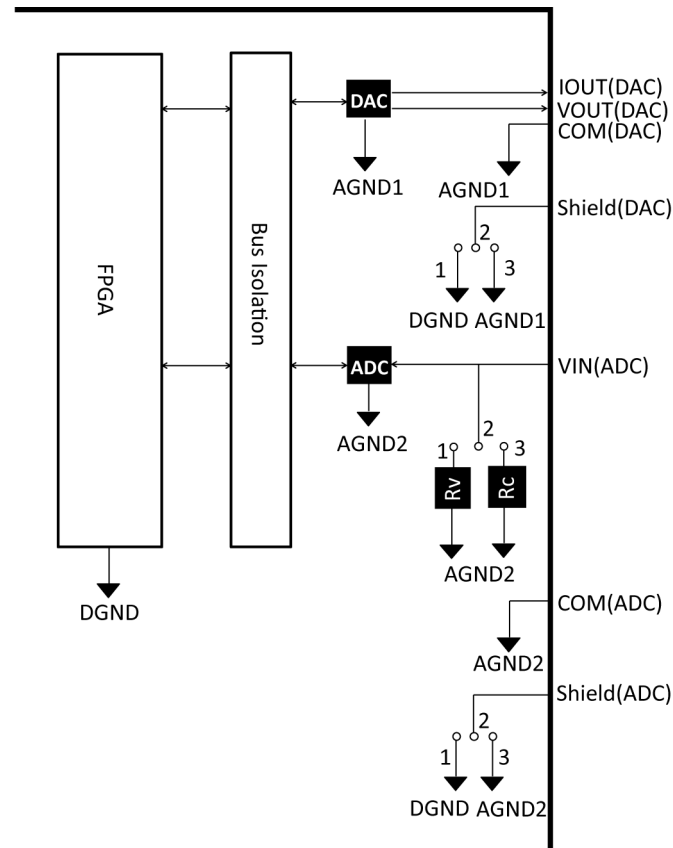

Rv: Voltage Input Terminating Resistance (100kΩ),

14.6.2 Board Configuration (Analog I/O Board)

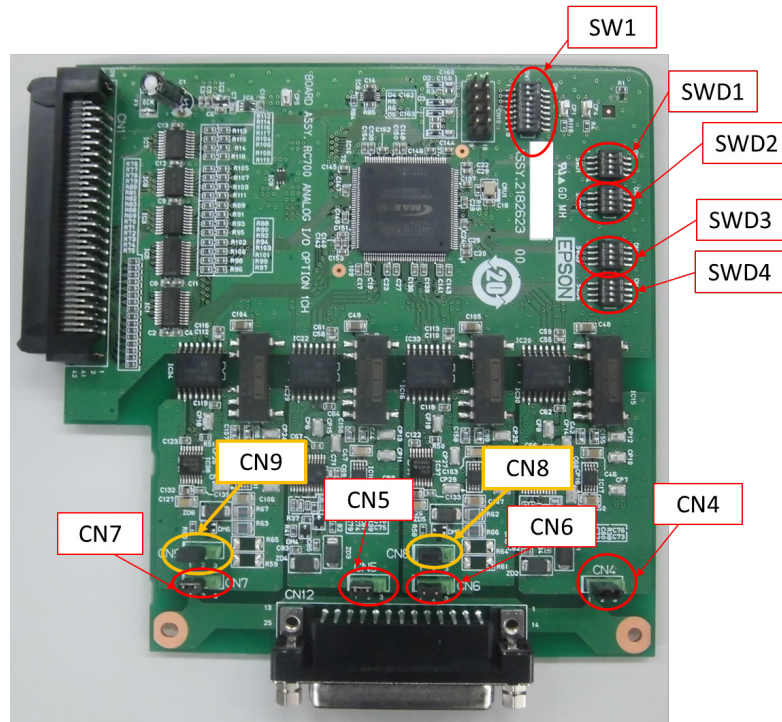

Configuration of Switch and Jumper

(1) Address Configuration (SW1): Address of the option board

Configuration	S1	S2	S3	S4	S5	S6	S7	S8
The first board	Off	Off	On	Off	Off	Off	Off	Off
The second board	Off	On	Off	Off	Off	Off	Off	Off
The third board	On	Off	Off	Off	Off	Off	Off	Off
The fourth board	Off	Off	Off	Off	Off	Off	Off	Off

SW1

S1
S2
S3
S4
S5
S6
S7
S8

S5 to S8: Not used. Please turn them OFF.

(2) Analog Output: Configuration

Voltage Current Switching Switch (SWD1): Voltage/current output

Range Switching Switch (SWD2): Output range

Channel	Output Mode	Range Configuration	SWD1 (voltage current switching)				SWD2 (range switching)			
			S1	S2	S3	S4	S1	S2	S3	S4
DAC 1 ch	Voltage output mode	±5V	On	Not Use	Not Use	Not Use	On	On	Not Use	Not Use
		±10V	On				On	Off		
		0~5V	On				Off	On		
		0~10V *	On				Off	Off		
	Current output mode	0~20mA	Off				On	On		
		4~20mA	Off				Off	Off		
DAC 2 ch	Voltage output mode	±5V	Not Use	On	Not Use	Not Use	Not Use	Not Use	On	On
		±10V		On					On	Off
		0~5V		On					Off	On
		0~10V *		On					Off	Off
	Current output mode	0~20mA		Off					On	On
		4~20mA		Off					Off	Off

*: Default: DAC default configuration (voltage output: 0 to 10V)

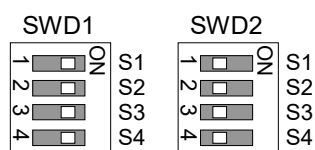

(3) Analog Input: Configuration

Voltage Current Switching Jumper (CN8/CN9): Current input/voltage input

1-2 pin short: Voltage input configuration

2-3 pin short: Current input configuration

Voltage Current Switching Switch (SWD1): Voltage/current input

Range Switching Switch (SWD3): Input range

Channel	Input Mode	Range Configuration	SWD1(voltage current switching)				CN8 (voltage current switching)	CN9 (voltage current switching)
			S1	S2	S3	S4		
ADC 1ch	Voltage Input Mode	±5.12V	Not Use	Not Use	On	Not Use	1-2 short	Not Use
		±10.24V			On		1-2 short	
		0 to 5.12V			On		1-2 short	
		0 to 10.24V *			On		1-2 short	
	Current Input Mode	0 to 24mA	Off	2-3 short				
ADC 2ch	Voltage Input Mode	±5.12V	Not Use	Not Use	On	Not Use	1-2 short	
		±10.24V			On		1-2 short	
		0 to 5.12V			On		1-2 short	
		0 to 10.24V *			On		1-2 short	
	Current Input Mode	0 to 24mA	Off	2-3 short				

Channel	Input Mode	Range Configuration	SWD3 (range switching)				SWD4
			S1	S2	S3	S4	
ADC 1ch	Voltage Input Mode	±5.12V	On	On	Not Use	Not Use	Off
		±10.24V	On	Off			
		0 to 5.12V	Off	On			
		0 to 10.24V *	Off	Off			
	Current Input Mode	0 to 24mA	Off	On			
ADC 2ch	Voltage Input Mode	±5.12V	Not Use	Not Use	On	On	Off
		±10.24V			On	Off	
		0 to 5.12V			Off	On	
		0 to 10.24V *			Off	Off	
	Current Input Mode	0 to 24mA	Off	On			

SWD4: Not used. Please turn them OFF.

*: Default: ADC default configuration (voltage input: 0 to 10.24V)



(4) Shield Configuration

“Frame Ground” and “User Ground” of the shield: CN4, CN5, CN6, and CN7

- 1-2 pin short : Frame ground (FG) shield configuration.
When you want to spread the shield noise to the robot Controller side.
- 2-3 pin short : User ground (UG) shield configuration.
When you want to insulate the shield by external connection device and robot Controller.
Or when you want to spread the shield noise to the external connection device side.

User Ground (UG): Analog ground (AGND) on the external connection device side.

Frame Ground (FG): Digital ground (DGND) inside the robot Controller.

Channel	Configuration	CN4	CN5	CN6	CN7
DAC1ch	FG Shield*	1-2 short	Not Use	Not Use	Not Use
	UG Shield	2-3 short			
DAC2ch	FG Shield *	Not Use	1-2 short	Not Use	Not Use
	UG Shield		2-3 short		
ADC1ch	FG Shield *	Not Use	Not Use	1-2 short	Not Use
	UG Shield			2-3 short	
ADC2ch	FG Shield *	Not Use	Not Use	Not Use	1-2 short
	UG Shield				2-3 short

*: Default

14.6.3 Confirmation with Epson RC+ (Analog I/O Board)

The Controller software automatically identifies the analog I/O board when mounting analog I/O board to the optional unit of the Controller. Therefore, no software configuration is needed.

Correct identification can be confirmed from Epson RC+.

- (1) Select the Epson RC+ menu-[Setup]-[System Configuration] to display the [System Configuration] dialog.

(2) Select [Controller]-[Inputs / Outputs]-[Analog I/O].

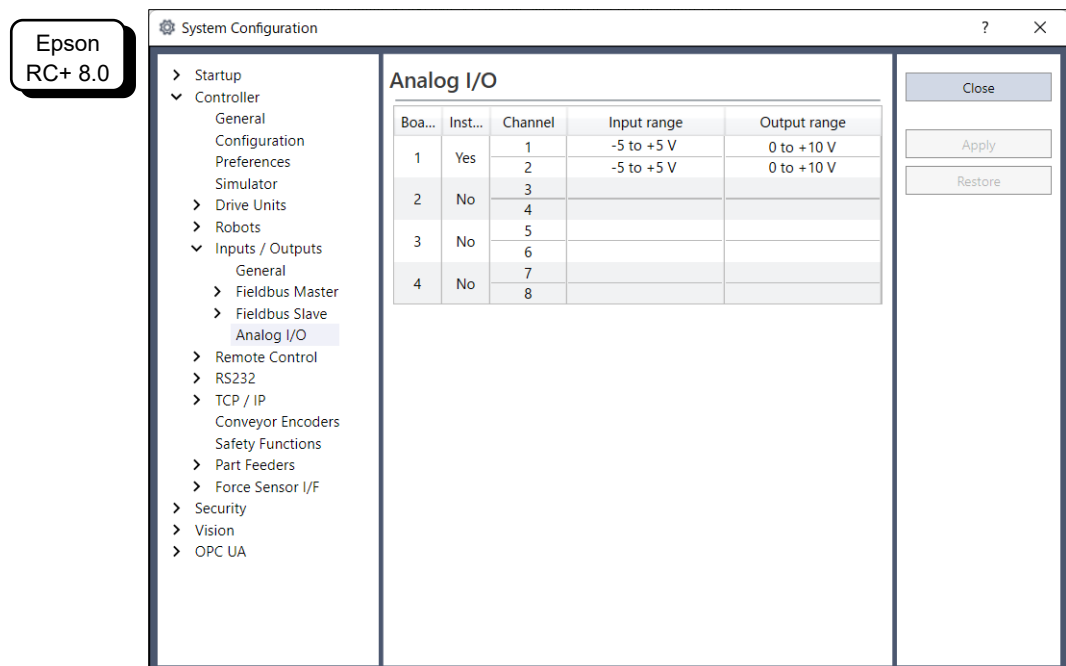
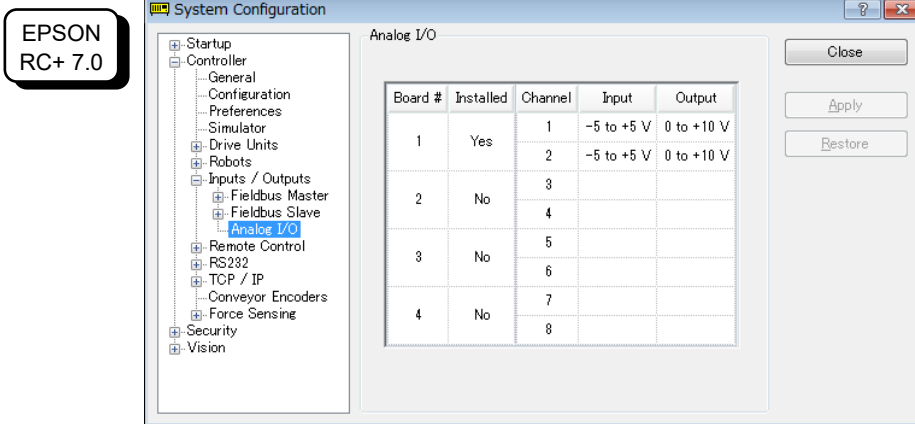

14.6.4 Input Circuit (Analog I/O Board)

Input resolution : 16 bit
 Input range : voltage input: 0 to 5.12V, 0 to 10.24V, $\pm 5.12V$, $\pm 10.24V$
 current input: 0 to 24mA
 Input impedance (Voltage/Current)
 : Applox.100k Ω /Applox.422 Ω
 Absolute rated voltage of input pins
 : $\pm 11V$
 Insulation specification : insulation between channels, bus insulation

14.6.5 Output Circuit (Analog I/O Board)

Output resolution : 16 bit
 Output range : voltage output: 0 to 5V, 0 to 10V, $\pm 5V$, $\pm 10V$
 current output: 0 to 20mA, 4 to 20mA
 Output impedance (Voltage/Current)
 : Applox.17 Ω /Applox.50M Ω
 Absolute rated voltage of output pins
 : $\pm 11V$
 Load resistance/capacity (@voltage output)
 : 1k Ω or more/5nF or less
 Load resistance /inductance (@voltage output)
 : 300k Ω or more/50mH or less
 Insulation specification : insulation between channels, bus insulation



CAUTION

- Analog input/output may not function properly if performing improper wiring or configuration.
- Operating under external noise may affect to the analog input/output. Make sure the noise environment such as weather the cable is shielded.
- Use the shield/twist cable.
- Never apply a voltage or current which is out of input/output range to the analog input/output pin. Applying a voltage more than $\pm 11V$ may result in malfunction of the board.
- Improper wiring or short circuit may cause malfunction of the parts on the board and then improper function of the robot system.

14.6.6 Pin Assignments (Analog I/O Board)

1CH Specifications

Signal	Signal	Signal	Signal
1	VOUT (DAC 1ch)	20	Shield (DAC 1ch)
2	COM (DAC 1ch)	21	IOUT (DAC 1ch)
3	Shield (DAC 1ch)	22	COM (DAC 1ch)
4	Not Used	23	Not Used
5	Not Used	24	Not Used
6	Not Used	25	Not Used
7	Not Used	26	Not Used
8	Not Used	27	Not Used
9	Not Used	28	Not Used
10	Not Used	29	Not Used
11	Not Used	30	Not Used
12	Not Used	31	Not Used
13	Not Used	32	Not Used
14	Not Used	33	Not Used
15	Not Used	34	Not Used
16	Not Used	35	Not Used
17	Not Used	36	Not Used
18	Not Used	37	Not Used
19	Not Used		

4CH Specifications

Signal	Signal	Signal	Signal
1	VOUT (DAC 1ch)	20	Shield (DAC 1ch)
2	COM (DAC 1ch)	21	IOUT (DAC 1ch)
3	Shield (DAC 1ch)	22	COM (DAC 1ch)
4	Not Used	23	Not Used
5	Not Used	24	Not Used
6	Not Used	25	Not Used
7	VIN (ADC 1ch)	26	Shield (ADC 1ch)
8	COM (ADC 1ch)	27	Not Used
9	Not Used	28	Not Used
10	Not Used	29	Not Used
11	VOUT (DAC 2ch)	30	Shield (DAC 2ch)
12	COM (DAC 2ch)	31	IOUT (DAC 2ch)
13	Shield (DAC 2ch)	32	COM (DAC 2ch)
14	Not Used	33	Not Used
15	Not Used	34	Not Used
16	Not Used	35	Not Used
17	Not Used	36	Not Used
18	VIN (ADC 2ch)	37	Shield (ADC 2ch)
19	COM (ADC 2ch)		

14.7 Force Sensor I/F Board

14.7.1 About Force Sensor I/F Board

You need to mount the Force Sensor I/F board in the option slot to communicate with the Force Sensor.

Force Sensor I/F board has one port for the connector to connect to Force Sensor and only one board is available.

When using the Force Sensor I/F board, one board expansion is available for RS-232C board.

Force Sensor can connect to all S250 series.

14.7.2 Board Configuration (Force Sensor I/F Board)

Board Appearance

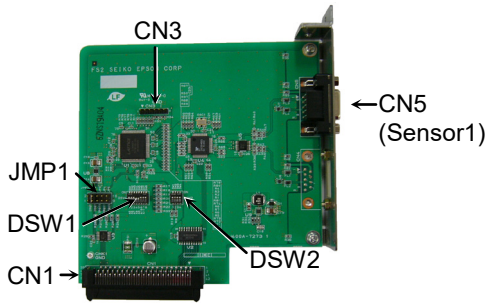

CN3 is all open.

Switch and Jumper Configuration

Do not change the following DSW1, DSW2, and JMP1 configurations.

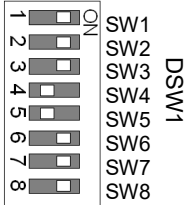
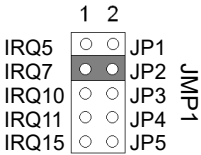

14.7.3 Confirmation with Epson RC+ (Force Sensor I/F Board)

The Controller software automatically identifies the Force Sensor I/F board when mounting Force Sensor I/F board to the optional slot of the Controller.

Correct identification can be confirmed from Epson RC+.

- (1) Select the Epson RC+ menu-[Setup]-[System Configuration] to display the [System Configuration] dialog.

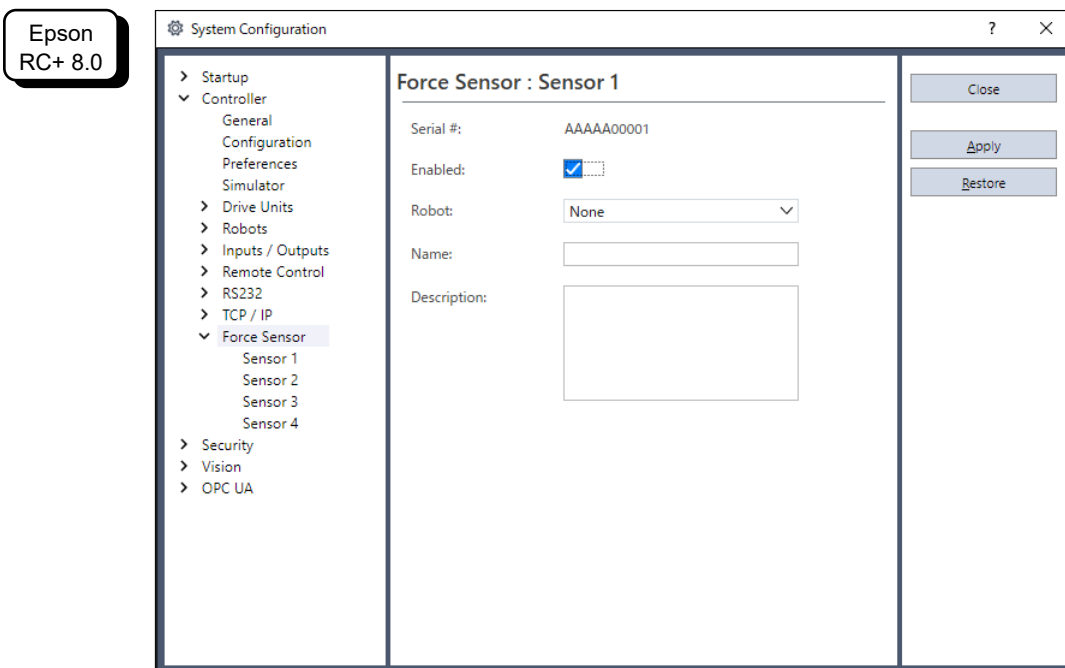
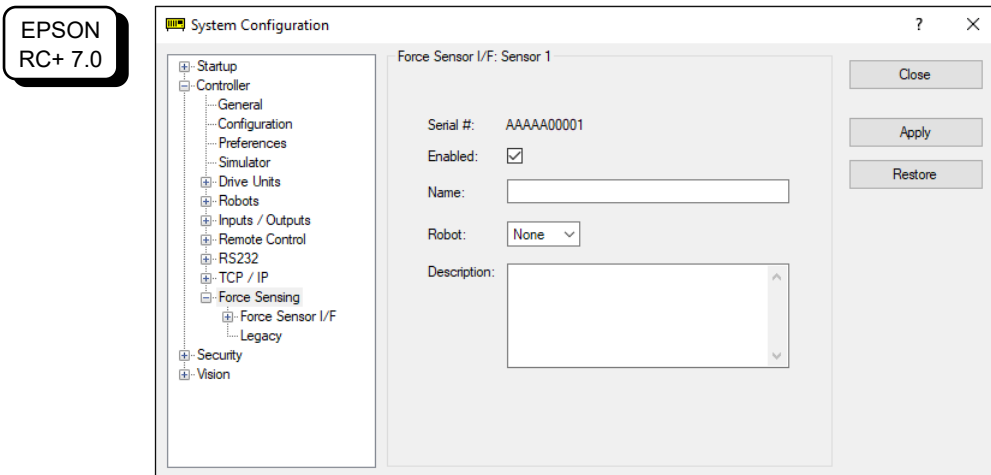

- (2) EPSON RC+ 7.0: Select [Force Sensing]-[Force Sensor I/F Unit].

Epson RC+ 8.0: Select [Force Sensor].

Epson RC+ Online Help

Epson RC+ Option Force Guide Manual

Software - *Configuring the Force Sensor I/F Unit*

14.8 EUROMAP67 Board

EUROMAP67 is a standardized interface for communications between Western-manufactured injection molding machines (IMM) and robots.

List of accessories

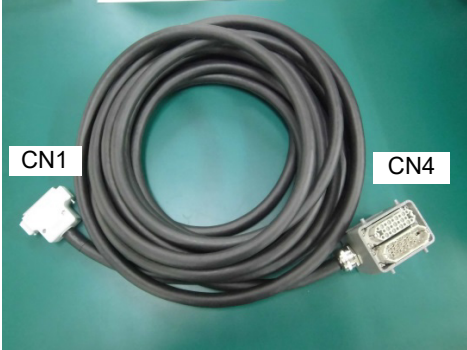
Parts Code	Parts	Note
2194667	EUROMAP67 Cable1 	Emergency Stop cable (CN2)
2194667	EUROMAP67 Cable2 	Connection cable Robot Controller(CN1) - IMM(CN4)
2165789	EUROMAP67Emergency Connector Plug	For emergency stop switch wiring Soldering plug (CN3)
2194882	EUROMAP67Emergency Connector Shell	For emergency stop switch wiring Shell kit (CN3)

Wire the emergency stop switch wiring connector (CN3).

Reference: 9.3 *Pin Assignments*

The connector signal placement is described below.

Reference: 14.8.11 *Emergency stop connector Pin Assignments*

List of connectors used

Connector No.	Manufacturer	Model
CN1	JAE	DD-50PF-N
CN2	3M	10126-3000PE, 10326-52K0-008
CN3 (accessory)	3M	10136-3000PE, 10336-52K0-008
CN4	Tyco	T1319320125-000 / T2020252201-000 / T2020252101-000

Connection outline

(IMM: Injection Molding Machine)

One EUROMAP67 board:

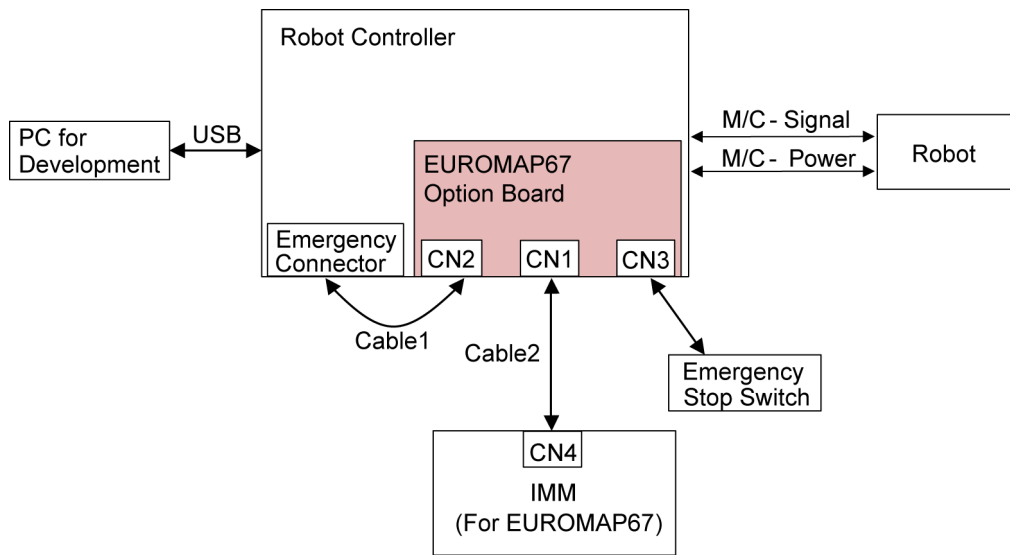

Two EUROMAP67 boards:

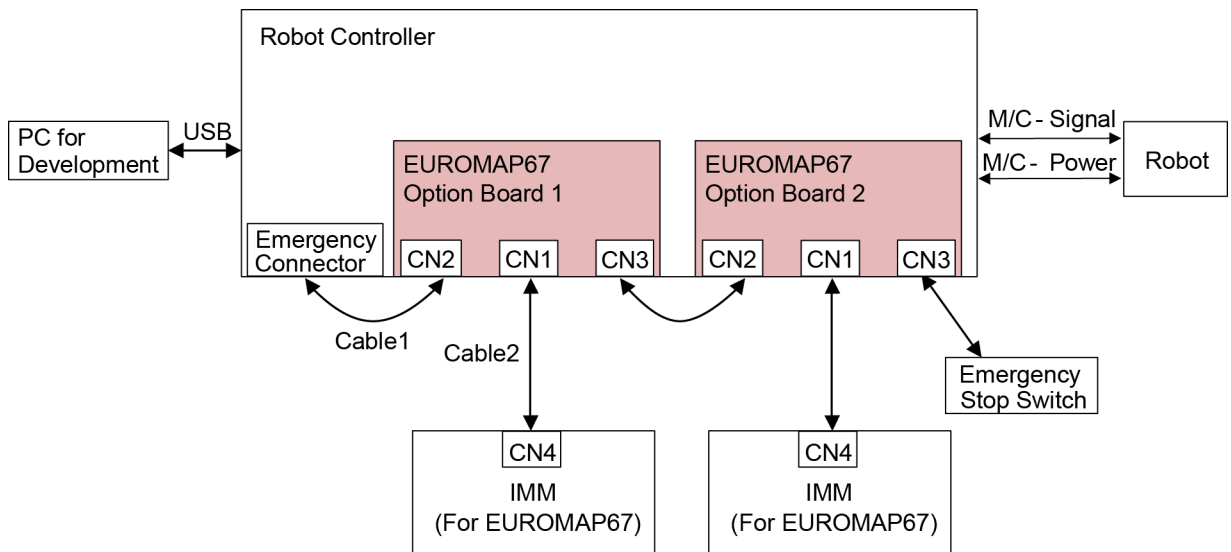

14.8.1 Notes on the EUROMAP67 Board

The EUROMAP67 board contains 15 inputs and 16 outputs on a single substrate.

You can install up to two EUROMAP67 board in the Controller.

The input and output bit numbers are assigned as follows.

Input Bit #	Output Bit #	Supported Hardware
192 to 206	192 to 208	The 1 st EUROMAP67 board
224 to 238	224 to 240	The 2 nd EUROMAP67 board

Outputs No.205 and No.237 are not used. However, the EUROMAP standard describes that they may potentially be used in the future.

EUROMAP67 pin definitions

EUROMAP connector (CN4) Pin No.	Signal Name	Note
ZA1 ZC1	Emergency stop of machine channel1	
ZA2 ZC2	Emergency stop of machine channel2	
ZA3 ZC3	Safety devices of machine channel1	
ZA4 ZC4	Safety devices of machine channel2	
ZA5	Reject	I/O Input (*1)
ZA6	Mold closed	I/O Input (*1)
ZA7	Mold open position	I/O Input (*1)
ZA8	Intermediate mold opening position	I/O Input (*1)
ZA9	Supply from handling device / robot	24V DC (Robot → IMM)
ZB2	Enable operation with handing device / robot	I/O Input (*1)
ZB3	Ejector back position	I/O Input (*1)
ZB4	Ejector forward position	I/O Input (*1)
ZB5	Core pullers 1 in position 1	I/O Input (*1)
ZB6	Core pullers 1 in position 2	I/O Input (*1)
ZB7	Core pullers 2 in position 1	I/O Input (*1)
ZB8	Core pullers 2 in position 2	I/O Input (*1)
ZC5	Reserved for future use by EUROMAP	I/O Input (*1)
ZC6	Reserved for future use by EUROMAP	I/O Input (*1)
ZC7	Reserved for future use by EUROMAP	I/O Input (*1)
ZC8	Not fixed by EUROMAP, manufacturer dependent	I/O Input (*1)
ZC9	Supply from handling device / robot	0V (Robot → IMM)
A1 C1	Emergency stop of robot channel1	
A2 C2	Emergency stop of robot channel2	
A3 C3	Mold area free	

EUROMAP connector (CN4) Pin No.	Signal Name	Note
A4 C4	Reserved for future use by EUROMAP	
A5	Not fixed by EUROMAP, manufacturer dependent	I/O Input (*1)
A6	Enable mold closure	I/O Input (*1)
A7	Enable full mold opening	I/O Input (*1)
A8	Reserved for future use by EUROMAP	I/O Input (*1)
A9	Supply from IMM	24V DC (IMM → Robot) (*1)
B2	Robot operation mode	I/O Input (*1)
B3	Enable ejector back	I/O Input (*1)
B4	Enable ejector forward	I/O Input (*1)
B5	Enable movement of core pullers 1 to position 1	I/O Input (*1)
B6	Enable movement of core pullers 1 to position 2	I/O Input (*1)
B7	Enable movement of core pullers 2 to position 1	I/O Input (*1)
B8	Enable movement of core pullers 2 to position 2	I/O Input (*1)
C5	Not fixed by EUROMAP, manufacturer dependent	I/O Input (*1)
C6	Reserved for future use by EUROMAP	I/O Input (*1)
C7	Reserved for future use by EUROMAP	I/O Input (*1)
C8	Not fixed by EUROMAP, manufacturer dependent	I/O Input (*1)
C9	Supply from IMM	0V (IMM → Robot)

*1: DO NOT input a voltage which exceeds 24V. Board may get damage and burnout.

14.8.2 Board Settings (EUROMAP67 Board)

Configure DIP-Switch (SW1) to enable the robot Controller to recognize the EUROMAP67 board.

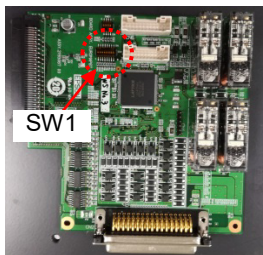
Board Appearance	Switch setting: Setup the DSW1	
	1 st board	2 nd board
	1 <input type="checkbox"/> NO	1 <input type="checkbox"/> NO
	2 <input type="checkbox"/> NO	2 <input checked="" type="checkbox"/> NO
	3 <input type="checkbox"/> NO	3 <input type="checkbox"/> NO
	4 <input type="checkbox"/> NO	4 <input type="checkbox"/> NO
	5 <input type="checkbox"/> NO	5 <input type="checkbox"/> NO
	6 <input type="checkbox"/> NO	6 <input type="checkbox"/> NO
	7 <input type="checkbox"/> NO	7 <input type="checkbox"/> NO
	8 <input type="checkbox"/> NO	8 <input type="checkbox"/> NO

14.8.3 Installation (EUROMAP67 Board)

For the install procedure, please contact the supplier of your region.

14.8.4 Confirming with Epson RC+ (EUROMAP67 Board)

The Controller software will automatically recognize the EUROMAP67 board when attaching it to the optional unit. This eliminates the need to configure software settings.

You can check whether the software has correctly recognized the EUROMAP67 board on the Epson RC+ screen.

- (1) Select Epson RC+ menu - [Setup] - [System Configuration] to display the [System Configuration] dialog box.

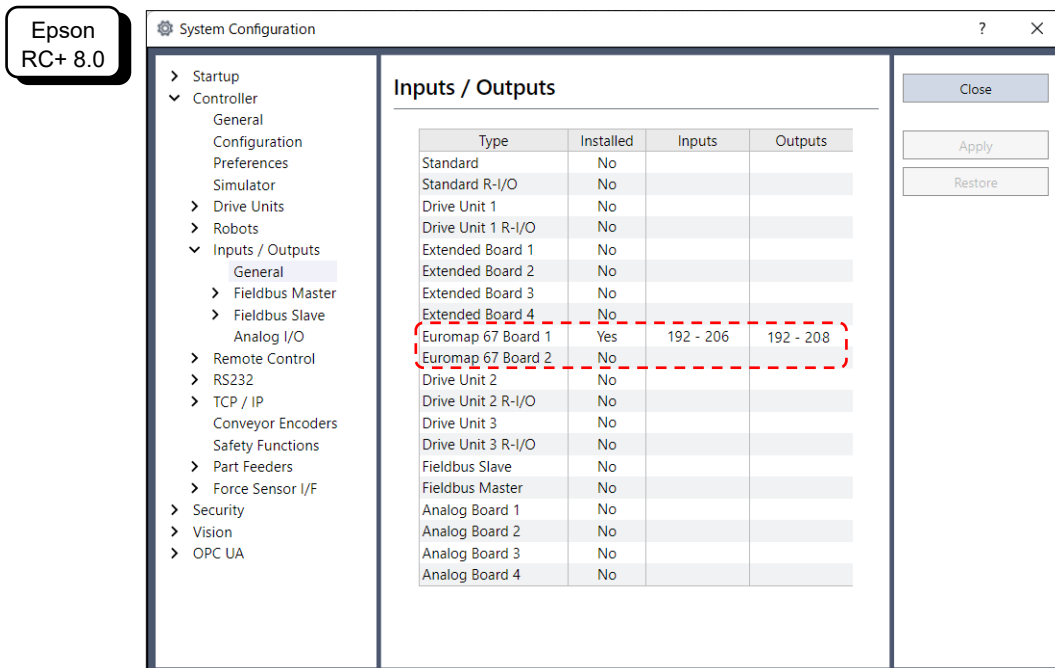
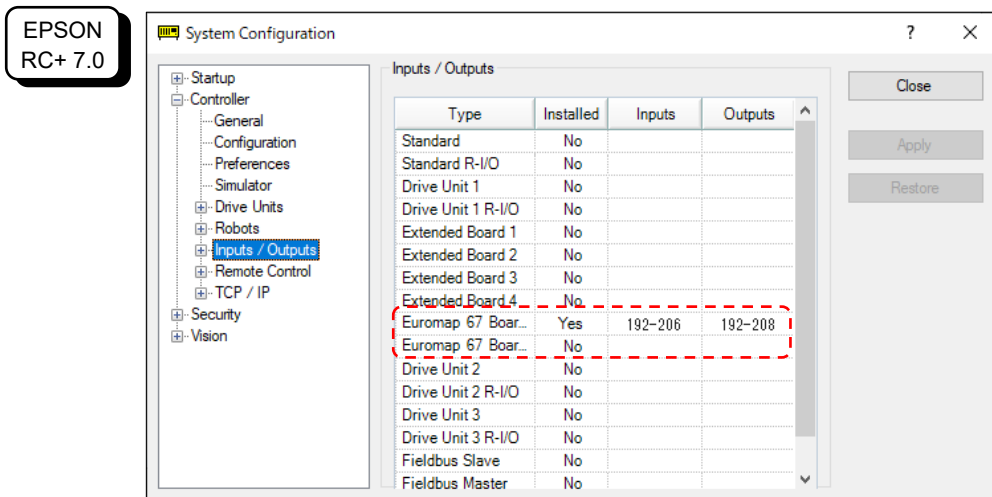

- (2) Select [Controller] - [Input/Output].
- (3) Check that the [Installed] is “Yes”.
The EUROMAP67 board has been recognized by the Controller software.
You can now select the compatible inputs and outputs to use.

14.8.5 Sample Project (EUROMAP67 Board)

You can use a sample project of EUROMAP 67 board.

The following describes procedures to use the sample project.

- (1) Select Epson RC+ menu - [Project]-[Open..].
- (2) Select [Projects] - [Samples] - [Euromap67Demo1].
- (3) Click the <Open> button.
- (4) Modify the project depending on the IMM.

14.8.6 Circuit Overview (EUROMAP67 Board)

EUROMAP67 Board: System diagram

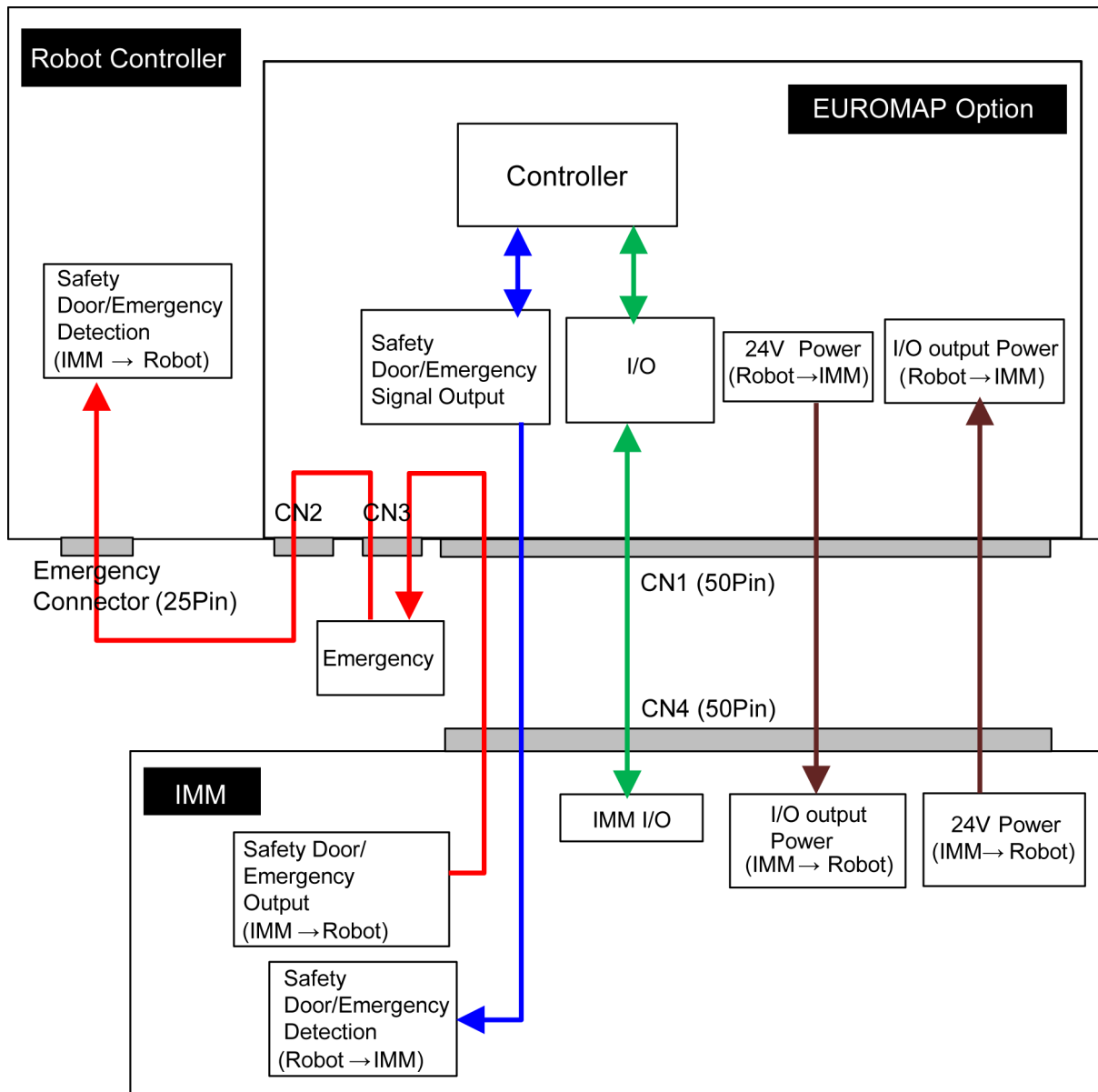

14.8.7 Input Circuit (EUROMAP67 Board)

Input Voltage Range : + 12 to 24 V \pm 10 %
 ON Voltage : + 10.8 V (MIN.)
 OFF Voltage : + 5 V (MAX.)
 Input Current : 10 mA TYP / + 24 V input

14.8.8 Output Circuit (EUROMAP67 Board)

Rated Output Voltage : + 12 V to 24 V \pm 10 %
 Maximum Output Current : TYP 100 mA / 1 output
 Output Driver : PhotoMOS relay
 On-resistance (average) : 23.5 Ω or less

EUROMAP67 board input/output circuit overview

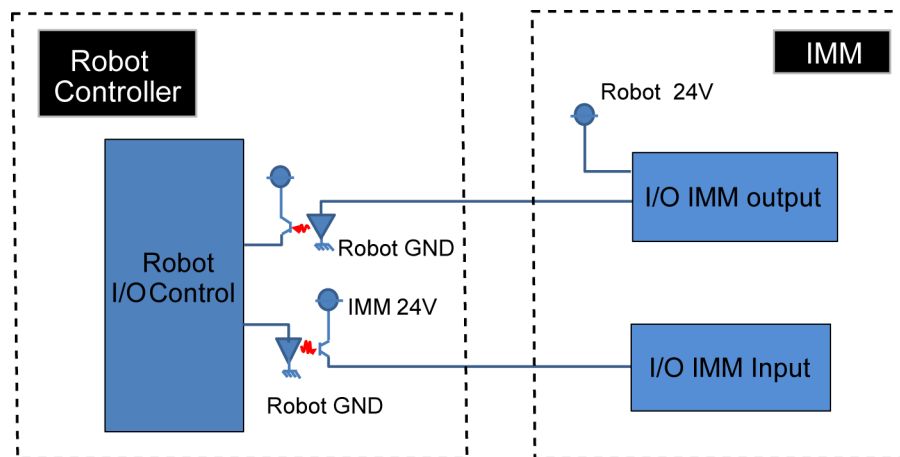

 CAUTION	<ul style="list-style-type: none"> ■ Input/output circuits do not have a built-in protection circuit to prevent short circuits or reverse connections. Take care to avoid wiring mistakes. Wiring mistakes may damage board parts and prevent the robot system from functioning properly. ■ Do not use a higher than rated voltage or current. Doing so may damage board parts and prevent the robot system from functioning properly. ■ Note that the I/O logic for controlling the IMM will vary depending on the molding machine. Confirm the proper logic to use before creating programs.
--	--

14.8.9 Emergency Stop, Safeguard (EUROMAP67 Board)

When the emergency stop switch is held down on the robot Controller:

A function is used to communicate the emergency stop instruction to the IMM.

The emergency stop instruction is communicated using a safety relay. A deposition detection function is also provided.

→ When deposition is detected, the robot Controller will set the emergency stop instruction communicated to the IMM to OPEN.

When an emergency stop occurs on the IMM side:

A function is used to communicate the emergency stop instruction to the robot Controller.

When the safety door has been opened on the IMM side:

A function is used to communicate the open safeguard instruction to the robot Controller.

EUROMAP67 Board: Overview of Emergency stop circuit

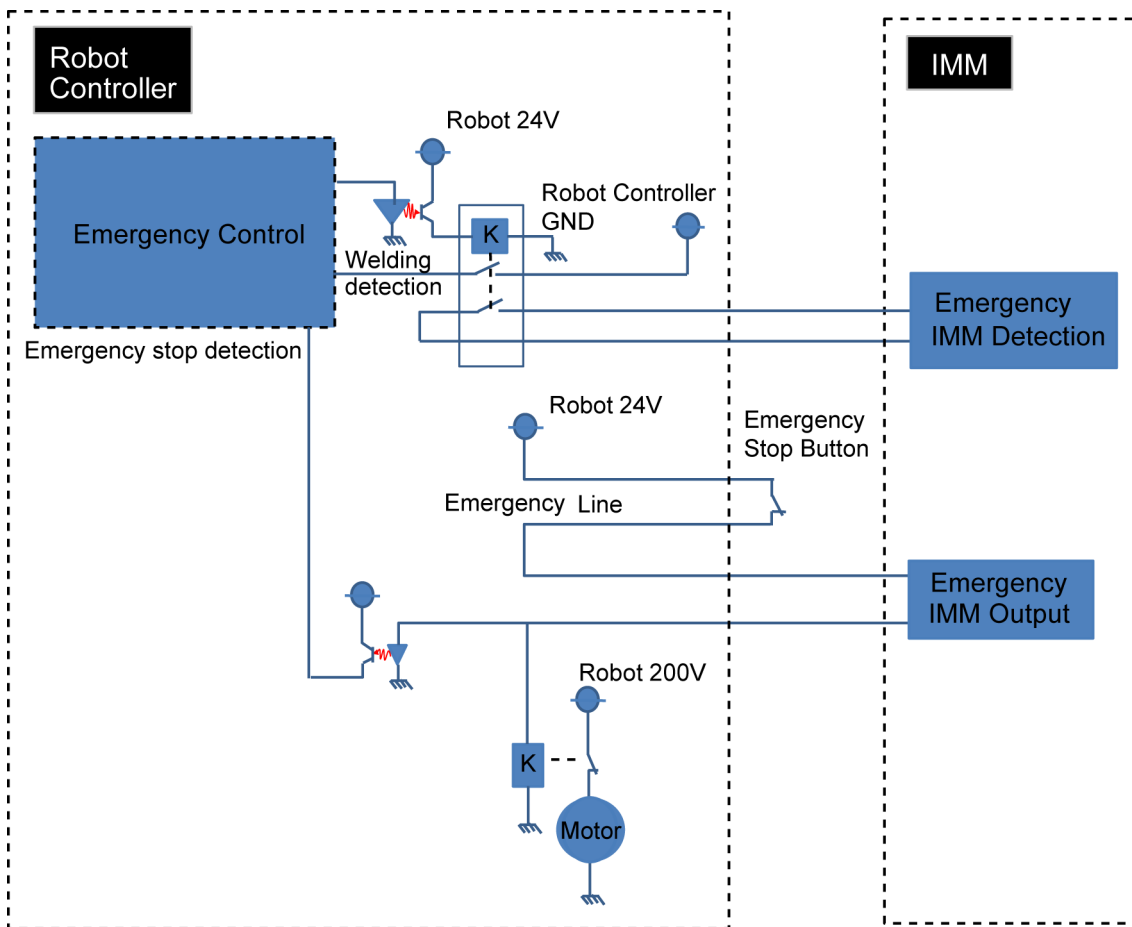

EUROMAP67 Board: Overview of Safety Door circuit

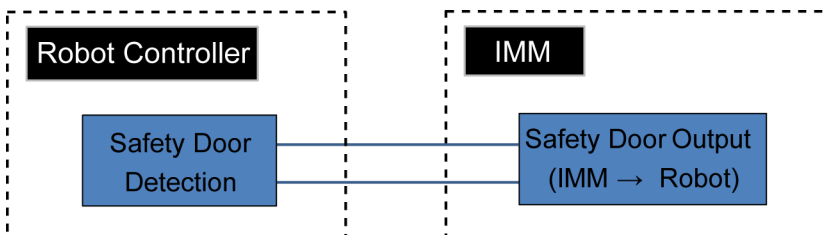

14.8.10 I/O Pin Assignments (EUROMAP67 Board)

I/O Pin Assignment table of the 1st EUROMAP67 board.

Signal Name	D-Sub connector (CN1) Pin No.	EUROMAP67 connector (CN4) Pin No.
Input No.192	33	ZA5 (*1)
Input No.193	32	ZA6 (*1)
Input No.194	50	ZA7 (*1)
Input No.195	49	ZA8 (*1)
Input No.196	48	ZB2 (*1)
Input No.197	47	ZB3 (*1)
Input No.198	31	ZB4 (*1)
Input No.199	30	ZB5 (*1)
Input No.200	15	ZB6 (*1)
Input No.201	14	ZB7 (*1)
Input No.202	46	ZB8 (*1)
Input No.203	45	ZC5 (*1)
Input No.204	29	ZC6 (*1)
Input No.205	28	ZC7 (*1)
Input No.206	13	ZC8 (*1)
Output No.192	41	A6 (*1)
Output No.193	7	A7 (*1)
Output No.194	8	A8 (*1)
Output No.195	24	B2 (*1)
Output No.196	25	B3 (*1)
Output No.197	42	B4 (*1)
Output No.198	43	B5 (*1)
Output No.199	9	B6 (*1)
Output No.200	10	B7 (*1)
Output No.201	26	B8 (*1)
Output No.202	27	C6 (*1)
Output No.203	11	C7 (*1)
Output No.204	4/3	A3/C3 (ModuleArea+/ModuleArea-)
Output No.205 (Not Used)	37/36	A4/C4 (Not Used)
Output No.206	12	C8 (*1)
Output No.207	40	A5 (*1)
Output No.208	44	C5 (*1)
24V (IMM)	1	A9 (*1)
GND (IMM)	2	C9 (*1)
Emergency1 (IMM)	39/38	ZA1/ZC1
Emergency2 (IMM)	21/20	ZA2/ZC2
Safety1 (IMM)	6/5	ZA3/ZC3
Safety2 (IMM)	23/22	ZA4/ZC4
24V (Robot)	17	ZA9
GND (Robot)	16	ZC9
Emergency1 (Robot)	35/34	A1/C1
Emergency2 (Robot)	19/18	A2/C2

*1: DO NOT input a voltage which exceeds 24V. Board may get damage and burnout.

I/O Pin Assignment table of the 2nd EUROMAP67 board.

Signal Name	D-Sub connector (CN1) Pin No.	EUROMAP67 connector (CN4) Pin No.
Input No.224	33	ZA5 (*1)
Input No.225	32	ZA6 (*1)
Input No.226	50	ZA7 (*1)
Input No.227	49	ZA8 (*1)
Input No.228	48	ZB2 (*1)
Input No.229	47	ZB3 (*1)
Input No.230	31	ZB4 (*1)
Input No.231	30	ZB5 (*1)
Input No.232	15	ZB6 (*1)
Input No.233	14	ZB7 (*1)
Input No.234	46	ZB8 (*1)
Input No.235	45	ZC5 (*1)
Input No.236	29	ZC6 (*1)
Input No.237	28	ZC7 (*1)
Input No.238	13	ZC8 (*1)
Output No.224	41	A6 (*1)
Output No.225	7	A7 (*1)
Output No.226	8	A8 (*1)
Output No.227	24	B2 (*1)
Output No.228	25	B3 (*1)
Output No.229	42	B4 (*1)
Output No.230	43	B5 (*1)
Output No.231	9	B6 (*1)
Output No.232	10	B7 (*1)
Output No.233	26	B8 (*1)
Output No.234	27	C6 (*1)
Output No.235	11	C7 (*1)
Output No.236	4/3	A3/C3 (ModuleArea+/ModuleArea-)
Output No.237 (Not Used)	37/36	A4/C4 (Not Used)
Output No.238	12	C8 (*1)
Output No.239	40	A5 (*1)
Output No.240	44	C5 (*1)
24V (IMM)	1	A9 (*1)
GND (IMM)	2	C9 (*1)
Emergency1 (IMM)	39/38	ZA1/ZC1
Emergency2 (IMM)	21/20	ZA2/ZC2
Safety1 (IMM)	6/5	ZA3/ZC3
Safety2 (IMM)	23/22	ZA4/ZC4
24V (Robot)	17	ZA9
GND (Robot)	16	ZC9
Emergency1 (Robot)	35/34	A1/C1
Emergency2 (Robot)	19/18	A2/C2

*1: DO NOT input a voltage which exceeds 24V. Board may get damage and burnout.

**14.8.11 Emergency stop connector Pin Assignments
(EUROMAP67 Board)**

Emergency stop connector (CN2) Pin Assignment table of the EUROMAP67 board.

Emergency stop connector (CN2) Pin No.	Signal Name	Function
1	ESW11	Emergency Stop switch contact
2	ESW12	Emergency Stop switch contact
3	ESTOP1+	Emergency Stop circuit 1+
4	ESTOP1-	Emergency Stop circuit 1-
5	Not Used	-
6	Not Used	-
7	SD11	Safety Door input 1
8	SD12	Safety Door input 1
9	24V	24V output
10	24V	24V output
11	24VGND	24VGND output
12	24VGND	24VGND output
13	Not Used	-
14	ESW21	Emergency Stop switch contact
15	ESW22	Emergency Stop switch contact
16	ESTOP2+	Emergency Stop circuit 2+
17	ESTOP2-	Emergency Stop circuit 2-
18	SDLATCH1	Safety Door Latch Release
19	SDLATCH2	Safety Door Latch Release
20	SD21	Safety Door input 2
21	SD22	Safety Door input 2
22	24V	24V output
23	24V	24V output
24	24VGND	24VGND output
25	24VGND	24VGND output
26	Not Used	-

Emergency stop connector (CN3) Pin Assignment table of the EUROMAP67 board.

Emergency stop connector (CN3) Pin No.	Signal Name	Function
1	ESW11	Emergency Stop switch contact
2	ESW12	Emergency Stop switch contact
3	ESTOP1+	Emergency Stop circuit 1+
4	ESTOP1-	Emergency Stop circuit 1-
5	Not Used	-
6	Not Used	-
7	SD11	Safety Door input 1
8	SD12	Safety Door input 1
9	24V	24V output
10	24V	24V output
11	24VGND	24VGND output
12	24VGND	24VGND output
13	Not Used	-
14	ESW21	Emergency Stop switch contact
15	ESW22	Emergency Stop switch contact
16	ESTOP2+	Emergency Stop circuit 2+
17	ESTOP2-	Emergency Stop circuit 2-
18	SDLATCH1	Safety Door Latch Release
19	SDLATCH2	Safety Door Latch Release
20	SD21	Safety Door input 2
21	SD22	Safety Door input 2
22	24V	24V output
23	24V	24V output
24	24VGND	24VGND output
25	24VGND	24VGND output
26	Not Used	-
27	Not Used	-
28	Not Used	-
29	Not Used	-
30	Not Used	-
31	Not Used	-
32	Not Used	-
33	Not Used	-
34	Not Used	-
35	Not Used	-
36	Not Used	-

Regular Inspection

Performing inspection properly is essential to prevent trouble and ensure safety.

This volume describes the inspection schedule and contents.

Inspect according to the schedule.



1. Regular Inspection for RC700-D

This chapter describes maintenance inspection procedures. Performing maintenance inspection properly is essential to prevent trouble and ensure safety.

Be sure to perform the maintenance inspections in accordance with the schedule.

1.1 Inspections and Schedules

Refer to 2. *Part Names and Functions* for the names and position of each part.

Inspection Point	Frequency	Method	Check Item
Controller	12 months	Turn ON/OFF motor and Restart	Activates without any error
Emergency Stop Button	12 months	When the motor turned on, activate the emergency stop button	Make sure that the seven-segment LED on the Controller displays EP. 
Safeguard	12 months	When the motor turned on, turn on the safeguard	Make sure that the seven-segment LED on the Controller displays SO. 
Fan Filter	1 months	Visual inspection and cleaning	No stain
Fan (Front)	1 months	Checking the operating sound	No noise
Fan (Rear)	1 months	Checking the operating sound	No noise
Battery	12 months	Visual inspection of seven-segment and LED	No alarm occurred

2. Backup and Restore

2.1 What is the Backup Controller Function?

The Controller configuration set by Epson RC+ can be stored with the “Backup Controller” function.

The Controller settings can be restored easily using the data previously stored with “Backup Controller” after a configuration mistake or Controller problem.

Be sure to execute “Backup Controller” before changing the Controller setup, before maintenance, or after teaching.

For some problems, backup may not be available before maintenance has to be performed. Be sure to backup the data after making changes, before problems occur.



“Controller status storage function” is one of the RC700-D functions. It saves the Controller setup data same as “Backup Controller.”

There data can be used as the backup data at restoring.

The methods for “Controller Status Storage” are as follows:

- A : “Controller backup to the USB memory”
For details, refer to *Functions 6. Memory Port*.
- B : “Export Controller backup function” in Epson RC+.
For details, refer to *Epson RC+ User’s Guide - [Import] Command (Project Menu)*.

2.2 Backup Data Types

The table below shows the files created with “Backup Controller”.

File Name	Overview	
Backup.txt	Information file for restore	File including information for restoring the Controller.
CurrentMnp01.PRM	Robot parameters	Stores information such as TISet.
InitFileSrc.txt	Initial configuration	Stores various Controller parameters.
MCSys01.MCD	Robot configuration	Stores connected Robot information.
All the files related to Project	Project related	All the project files transferred to the Controller. Includes program files when Epson RC+ is configured to transfer source code to the Controller.
GlobalPreserves.dat	Global Preserve variables	Saves values of Global Preserve variables.
WorkQueues.dat	WorkQue information	Saves information of Queues information of the WorkQue.

2.3 Backup

Backup the Controller status from the Epson RC+.

- (1) Select Epson RC+ menu-[Tools]-[Controller] to display the [Controller Tools] dialog.

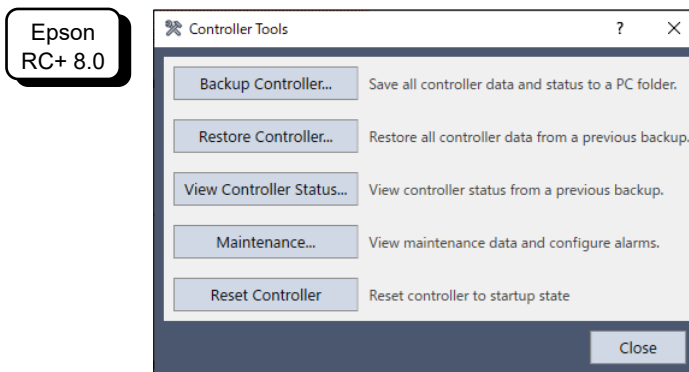
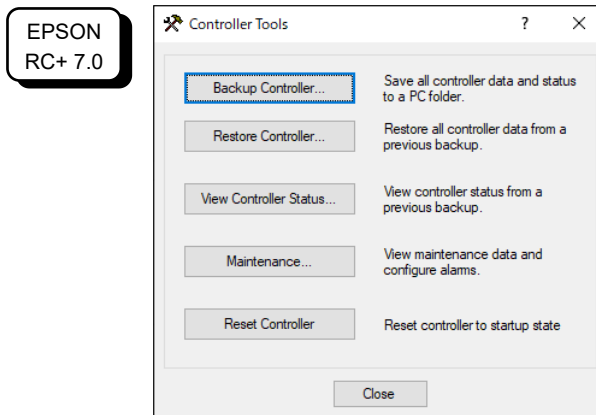

- (2) Click the <Backup Controller...> button to display the [Browse For Folder] dialog.

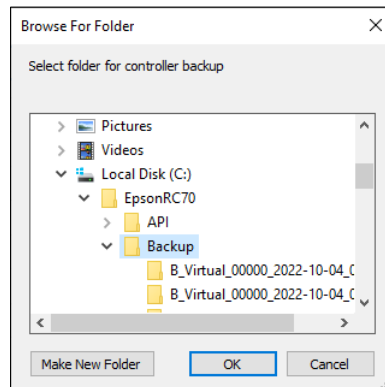

- (3) Specify the folder to save the backup data. Create a new folder if desired.
- (4) Click the <OK> button. A folder is created in the specified folder containing the backup data with a name in the following format.

“B_Controller type_serial number_date”



- Do not edit the backup files. Otherwise, operation of the robot system after data restoration to the Controller is not assured.

2.4 Restore

Restore the Controller status from the Epson RC+.

 CAUTION	<ul style="list-style-type: none"> ■ Make sure that the data used for restore was saved previously for same Controller. ■ Do not edit the backup files. Otherwise, operation of the robot system after data restoration to the Controller is not assured.
---	---

(1) Select the Epson RC+ menu-[Tools]-[Controller] to display the [Controller Tools] dialog.

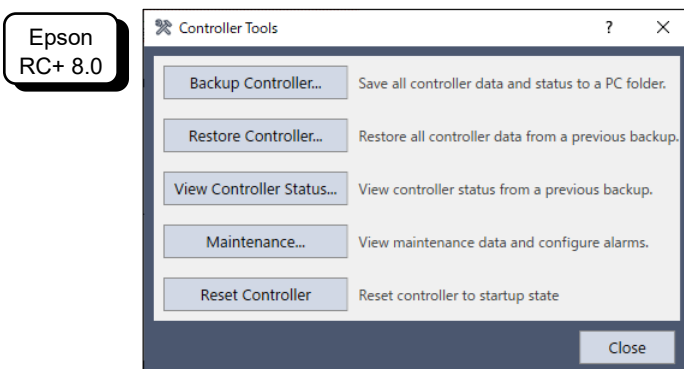
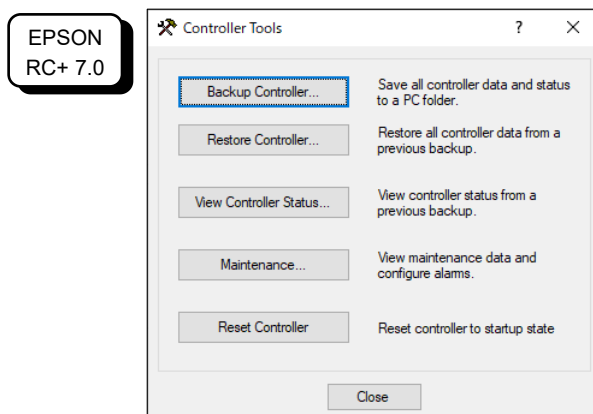

(2) Click the <Restore Controller...> button to display the [Browse For Folder] dialog.

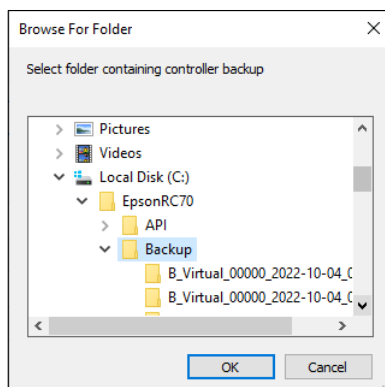

(3) Specify the folder that contains the backup data. Backup data folders are named using the following format:
 “B_Controller type_serial number_date”

NOTE  Data saved to the USB memory by the Backup Controller function can also be specified for restore.

(4) Click the <OK> button to display the dialog to select the restore data.

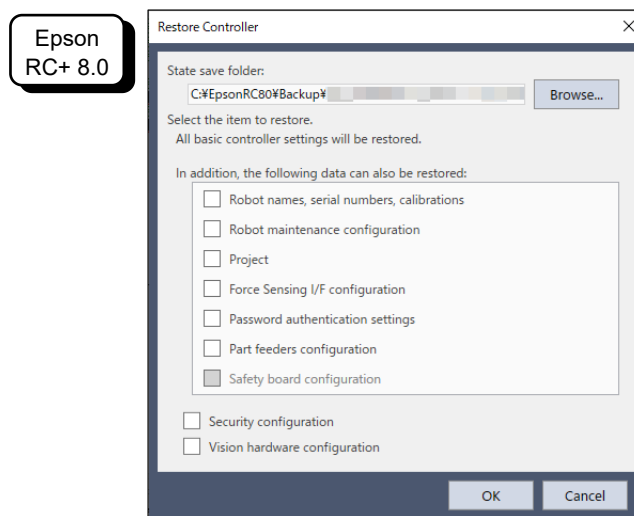
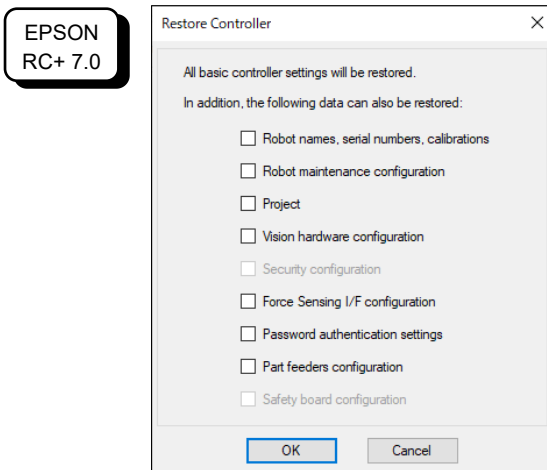

Robot name, serial #, calibration

This checkbox allows you to restore the robot name, robot serial number, Hofs data, and CalPIs data. Make sure that the correct Hofs data is restored. If the wrong Hofs data is restored, the robot may move to wrong positions.

This is not selected by the default setting.

Robot maintenance configuration

This checkbox allows you to restore the robot alarm related files.

For details, refer to 3. Alarm.

This is not selected by the default setting.

Restoring saved backup data when check box Epson RC+ Menu- [Setup]- [System Configuration]- [Controller]- [Preferences]- [Enable robot maintenance data] is checked, the robot maintenance data is not applied if the box is not checked. So be careful.

Project

This checkbox allows you to restore the files related to projects.

The default is unchecked.

When a project is restored, the values of Global Preserve variables are loaded.

For details about Global Preserve variable backup, refer to *Epson RC+ User's Guide - [Display Variables] Command (Run Menu)*.

Vision hardware configuration

This checkbox allows you to restore the vision hardware configuration.

For details, refer to *Epson RC+ option Vision Guide*.

This is not selected by the default setting.

Security configuration checkbox

This checkbox allows you to restore the security configuration.

For details, refer to *Epson RC+ User's Guide - Security*.

This is not selected by the default setting.

Force Sensing I/F configuration

This checkbox allows you to restore the Force Sensing I/F configuration.

For details, refer to *Epson RC+ option Vision Guide*.

This is not selected by the default setting.

Password authentication settings

This checkbox allows you to restore the setting of authentication for PC connection.

The authentication password for PC connection and the setting to disable connection authentication are restored.

This is not selected by the default setting.

- (5) Click the <OK> button to restore the system information.

NOTE Restore the system configuration saved using Backup Controller only for the same system.

When different system information is restored, the following warning message appears.

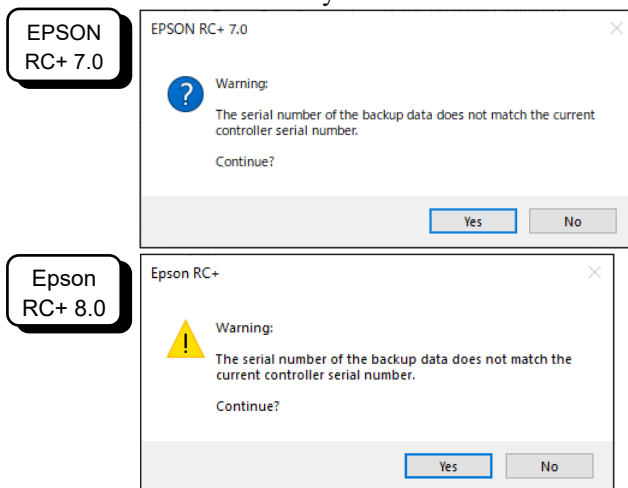

Click the <No> button (do not restore data) except for special situations such as Controller replacement.

NOTE When restoring the backup including unsupported robot information to the target Controller, an error occurs.

NOTE During the restoration, IP address is not restored in order to prevent unexpected communication interruptions due to overwriting of the IP address. The previous IP address set on the Controller is retained.

3. Alarm

When the batteries (lithium batteries) drain, an alarm warning voltage reduction occurs. However, the alarm does not guarantee the battery lives until replacement, and it is necessary to replace the batteries immediately.

In addition, the parts for the Manipulator joints may cause accuracy decline or malfunction due to deterioration of the parts resulting from long term use. If the robot breaks down due to deterioration of the parts, it will take significant time and cost for repair.

The following sections describe the alarm function which announces the following maintenance timings in order to perform maintenance well ahead of time before the warning error.



When using Epson RC+ 8.0, controller firmware Ver.7.5.4.x or later is required.

3.1 Maintenance

The recommended replacement time can be configured for the Controller batteries, robot grease, timing belts, motors, reduction gear units, and ball screw spline units.

 CAUTION	<ul style="list-style-type: none"> ■ Make sure that the date and time on the Controller are set correctly. The maintenance cannot function properly with improper date and time setting. ■ If the CPU board or CF is replaced, the maintenance information may be lost. When you replaced these parts, confirm the date and time of the Controller and the maintenance information.
-------------	---



Maintenance is enabled at shipment.

If enabled, the maintenance information for the battery, timing belts, motors, reduction gear units, ball screw spline unit, and grease up will be configured automatically when the robot is configured or changed.

Ball screw spline unit on the Joint # 3

When the robot is deleted from the configuration, the maintenance information will also be automatically deleted.

For details on the robot configuration, refer to *the Epson RC+ User's Guide - Setting the Robot Model*.

 CAUTION	<ul style="list-style-type: none"> ■ Changing of the robot should be done carefully. The alarm setting will be reset when the robot is changed.
-------------	--



The robot maintenance information depends on the Controller where the robot is configured to. If the robot is replaced with the other robot with a different serial number, the maintenance information will not function properly. When you replace the robot, edit the maintenance information.

For details on the maintenance information editing, refer to *3.3 How to Edit the Maintenance Information*.

3.2 How to View the Maintenance Information

The following shows the procedure to check the configured maintenance information.

- (1) Select the Epson RC+ menu-[Tools]-[Maintenance] to display the [Controller Tools] dialog box.

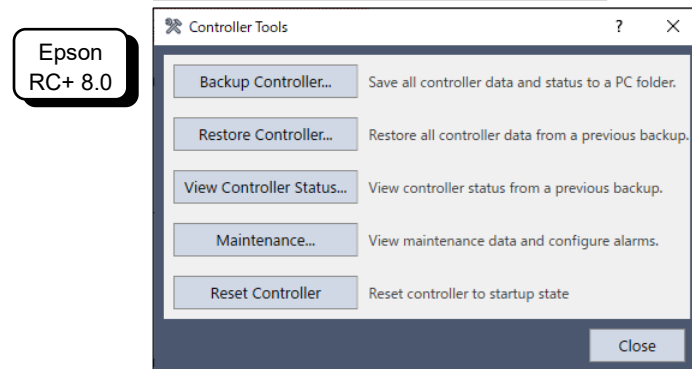
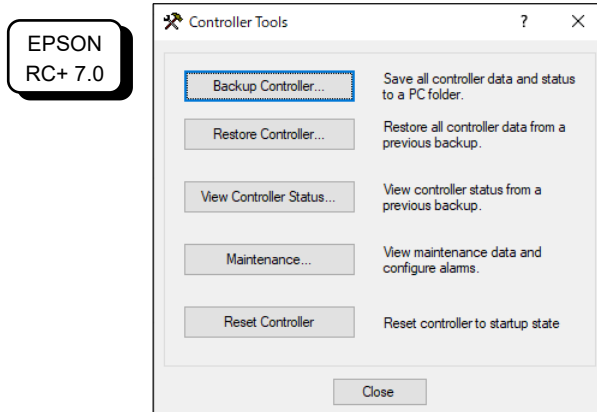

- (2) To check the Controller maintenance information, click the <Maintenance> button and display the [Maintenance] dialog box.

EPSON
RC+ 7.0

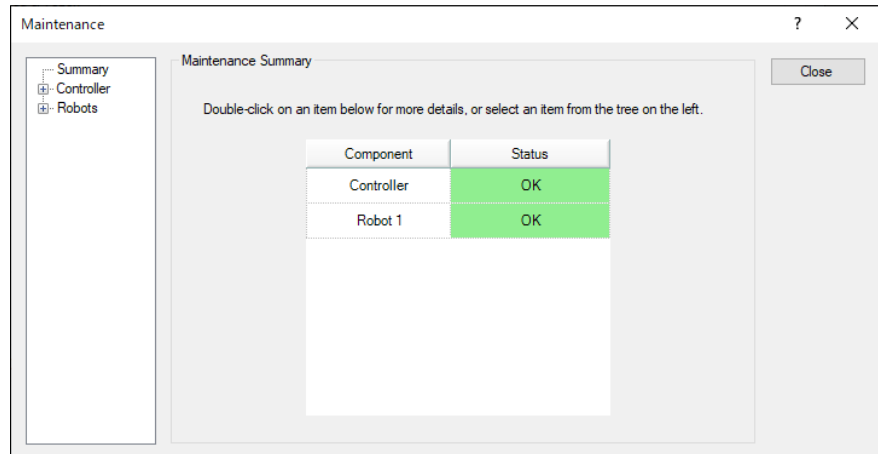

Epson
RC+ 8.0

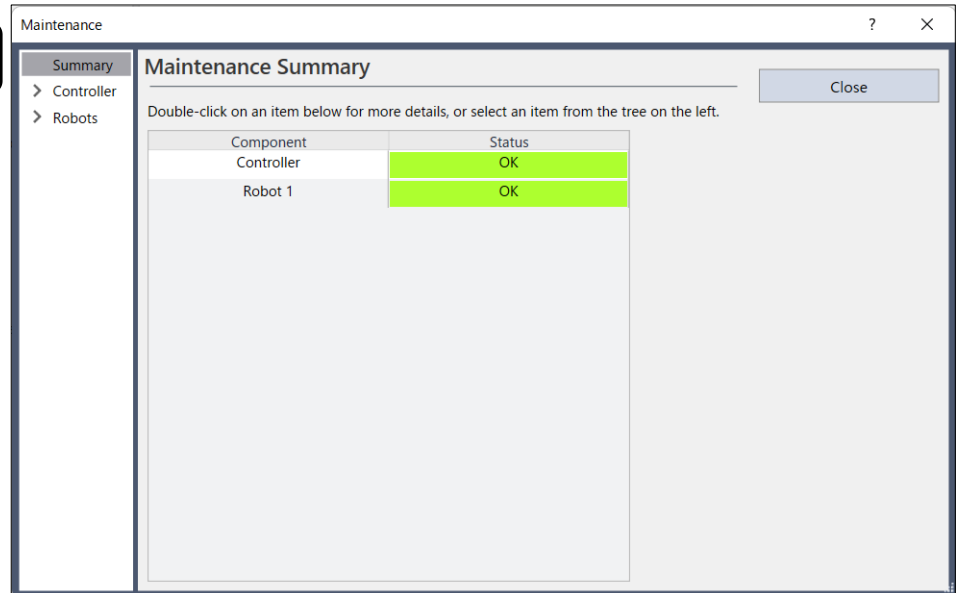

- (3) Select “General” or specify the axis from the tree to display information of the target parts.

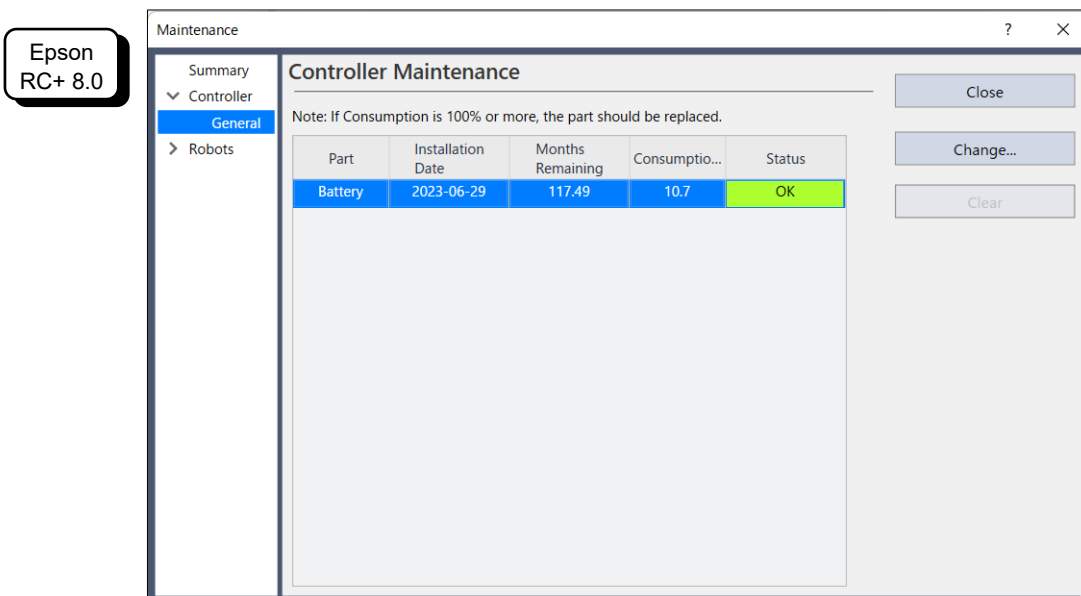
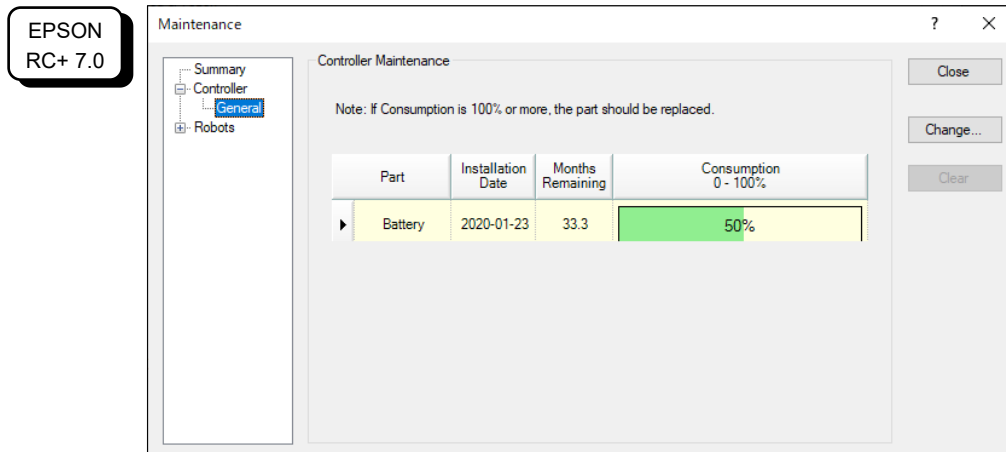

NOTE  The recommended replacement time for the battery is calculated based on the battery capacity and the Controller ON time. The battery may run out if it passes the recommended replacement time.

The recommended replacement time for the grease is calculated based on the elapsed days since date of grease up. The replacement time may be shorter or longer depending on usage condition, such the load applied on the robot.

The recommended replacement time for the parts (timing belts, motors, reduction gear units, and ball screw spline unit) is when it reaches the L10 life (time until 10% failure probability). In the dialog window, the L10 life is displayed as 100%.

Remaining months is calculated based on the past operation conditions.

Enable to set the period for calculation by “HealthCalcPeriod” command. (Default: seven days of the Controller ON time)

Remaining months may not be calculated properly until the period for the calculation passed.

3.3 How to Edit the Maintenance Information

The following shows the procedure to edit the configured maintenance information.

- (1) Select the Epson RC+ menu-[Tools]-[Maintenance] to display the [Controller Tools] dialog box.
- (2) To edit the maintenance information, display the [Maintenance] dialog box.
- (3) Select “General” or specify the axis from the tree to display information of the target parts.
- (4) Select the alarm to be changed and click the <Change> button.
- (5) Display the [Change Alarm] dialog box and enter any of the followings.

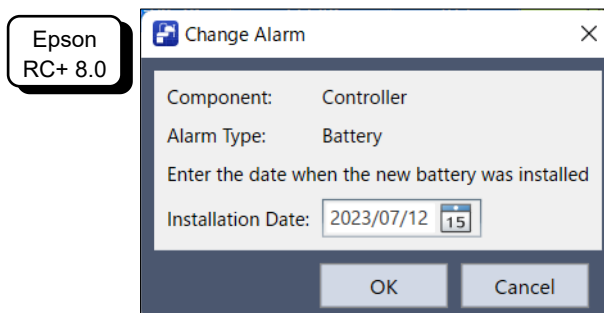
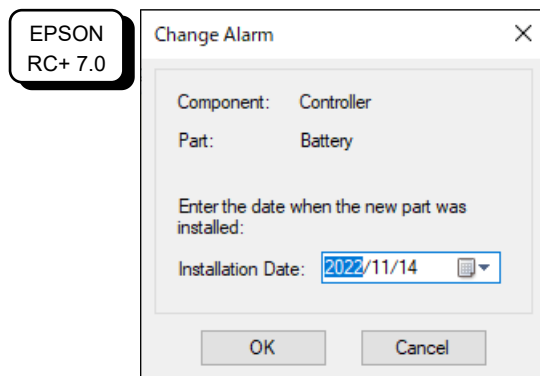

Purchase or replacement date of the battery

Date of grease up

Purchase or replacement date of the timing belt

Purchase or replacement date of the motor

Purchase or replacement date of the reduction gear unit

Purchase or replacement date of the ball screw spline unit

- (6) Click the <OK> button and change the specified alarm information.

NOTE



The offset can be set for the consumption rate of already installed parts.

Follow the steps below to calculate a rough offset setting value.

1. Measure the usable months for the past operation by HealthRBAAnalysis.
2. Confirm the past Motor ON time in the Controller status viewer.

3. Calculate a rough offset value with the following formula.

$$\text{Offset} = 100 \times \frac{\text{Motor On time}}{24 \times 30.4375 \times \text{Usable months}}$$

For details, refer to the following manual.

Epson RC+ SPEL+ Language Reference

3.4 Alarm Notifying Method

The Controller status becomes warning and displays warning message if any parts required to perform replacement or grease up.

For details, refer to the following manual.

Status Code / Error Code List

The alarm notifying method can be configured by the output bit of the Remote I/O.

The Remote I/O can be configured in the Epson RC+ - [Setup] - [System Configuration] - [Controller] - [Remote Control].

For details, refer to *Epson RC+ User's Guide - Remote I/O*.

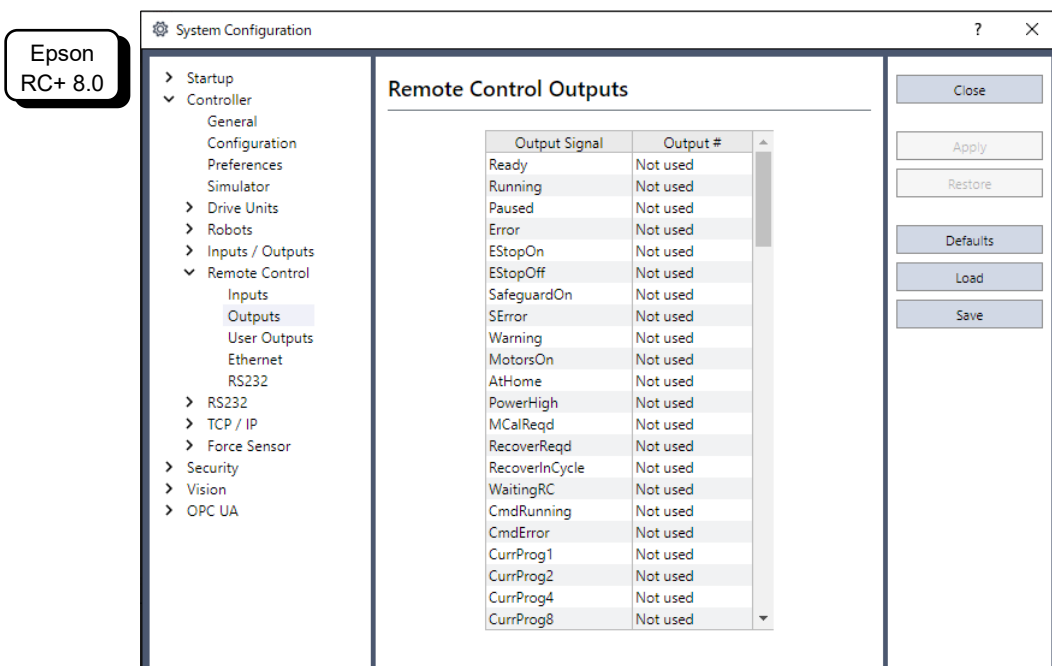
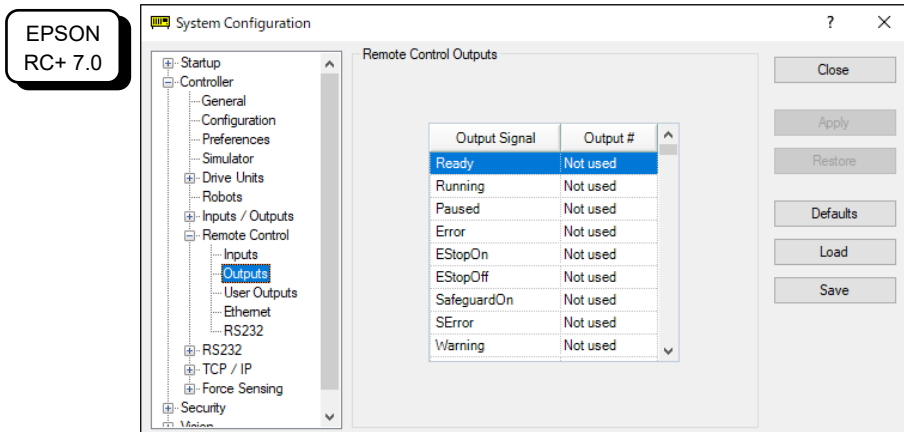

The Controller enters the warning state if an alarm occurs.

Set Alarm1 to Alarm 9 in Output bit of remote I/O is checking of warning occurrence in every 5 minutes.

The output timing is different from the alarm occurrence of the controller. It may be output to the remote I / O up to 5 minutes after the alarm is occurred on the controller.

3.5 How to Cancel the Alarm

An alarm occurs when the consumption rate of the parts reaches 100%.



The alarm cannot be canceled by executing the Reset command or restarting the Controller.

The alarm can be canceled by following methods.

Epson RC+ [Maintenance] dialog box.

HealthCtrlReset Command

HealthRBReset Command

Refer to *3.3 How to Edit the Maintenance Information* to change the alarm information in the same steps.

Appendix

Appendix A: Option Parts List

Part Name	Code	Old Code	Note
Expansion I/O Board (Source type)	R12NZ9003P	R12B040302	
Expansion I/O Board (Sink type)	R12NZ9003Q	R12B040303	
RS-232C Board	R12NZ9004E	R12B040726	
DeviceNet Board	R12NZ9004F	R12B040727	DeviceNet module is mounted on the Fieldbus Board.
PROFIBUS Board	R12NZ9004H	R12B040729	PROFIBUS-DP module is mounted on the Fieldbus Board.
CC-Link Board	R12NZ9004J	R12B040730	CC-Link module is mounted on the Fieldbus Board.
PROFINET Board	R12NZ900A6	R12N747051	PROFINET module is mounted on the Fieldbus Board.
EtherNet/IP Board	R12NZ900A7	R12N747061	EtherNet/IP module is mounted on the Fieldbus Board.
EtherCAT Board	R12NZ900CL	–	EtherCAT module is mounted on the Fieldbus Board.
PG Board	R12NZ900A8	R12N748011	
Analog I/O Board (1CH)	R12NZ900WZ	–	
Analog I/O Board (4CH)	R12NZ900X1	–	
Force Sensor I/F Board (FS2)	2184536	–	
EUROMAP67 Board	R12NZ90104	–	
EUROMAP67 Board (without IMM connection cable)	R12NZ9010A	–	EUROMAP67 without Cable2

