

Robot Controller Option
Teach Pendant

TP1

Rev.10

ENM231P5564F

Original instructions

Robot Controller Option Teach Pendant TP1 Rev.10

Robot Controller Option
Teach Pendant

TP1

Rev.10

FOREWORD

Thank you for purchasing our robot products.
This manual contains the information necessary for the correct use of the Teach Pendant.
Please carefully read this manual and other related manuals before installing the robot system.
Keep this manual handy for easy access at all times.

The robot system and its optional parts are shipped to our customers only after being subjected to the strictest quality controls, tests, and inspections to certify its compliance with our high performance standards. Please note that the basic performance of the product will not be exhibited if our robot system is used outside of the usage conditions and product specifications described in the manuals.

This manual describes possible dangers and consequences that we can foresee. Be sure to comply with safety precautions on this manual to use our robot system safely and correctly.

TRADEMARKS

Microsoft, Windows, and Windows logo are either registered trademarks or trademarks of Microsoft Corporation in the United States and/or other countries. Other brand and product names are trademarks or registered trademarks of the respective holders.

TRADEMARK NOTATION IN THIS MANUAL

Microsoft® Windows® 8 operating system
Microsoft® Windows® 10 operating system
Microsoft® Windows® 11 operating system
Throughout this manual, Windows 8, Windows 10 and Windows 11 refer to above respective operating systems. In some cases, Windows refers generically to Windows 8, Windows 10 and Windows 11.

NOTICE

No part of this manual may be copied or reproduced without authorization.
The contents of this manual are subject to change without notice.
Please notify us if you should find any errors in this manual or if you have any comments regarding its contents.

MANUFACTURER

SEIKO EPSON CORPORATION



CONTACT INFORMATION

Contact information is described in “SUPPLIERS” in the first pages of the following manual:

Robot System Safety Manual Read this manual first

Before Reading This Manual

Following descriptions are indicated throughout the manual by these symbols.

<p>NOTE </p>	<p>The “NOTE” sections describe important information to be followed for operating the Robot system.</p>
<p>TIP </p>	<p>The “TIP” sections describe hints for easier or alternative operations.</p>

 NOTE When using RC700 / RC90 option TP1 with the Robot Controller RC180, RC170, or RC620, refer to the following manuals.

When connecting TP1 to RC180 / RC170 robot controllers:

RC170 / RC180 option Teach Pendant TP1 manual

When connecting TP1 to RC620 robot controllers:

Robot Controller RC620 - 14. Option : Teach pendant TP1

 NOTE A coordinate point including the arm pose is defined as “position (point),” and the data is called “point data.”

Control System Configuration

This option is used with the following combinations of Controllers and software.

TYPE A:

Controller	Software
RC700	EPSON RC+ 7.0
RC90-B	EPSON RC+ 7.0

TYPE B: Robot Controller RC90 with the following label attached.

Label	Controller	Software
	RC90	EPSON RC+ 7.0

		RC90 controller firmware
		Ver.7.0.2.0
EPSON RC+ 7.0	Before Ver.7.0.1	!!!
	Ver.7.0.2 or later	OK

OK: Compatible All functions of the EPSON RC+ 7.0 and the Controller are available.

!!!: Compatible Connection is OK. We recommend using EPSON RC+7.0 Ver. 7.0.2 or later.

NOTE



This option is not available for Robot Controller RC90 (EPSON RC+ 5.0) without the label.

NOTE



Manual PDF for TYPE B is available from EPSON RC+ 7.0 Ver. 7.0.2

Functions & Installation

1. Safety	3
1.1 Conventions	3
1.2 Safety Precautions.....	3
1.3 EMERGENCY STOP.....	6
1.4 Mode Selector Key Switch.....	7
1.5 Using Teach Pendant in Safeguarded Area.....	8
2. Specifications	9
2.1 Part Names and Functions	9
2.2 Standard Specifications	11
2.3 Outer Dimensions	11
3. Installation	12
3.1 Contents.....	12
3.2 Environmental Conditions.....	12
3.3 Operating Precautions	12
3.4 Wall Bracket (Option).....	13
3.4.1 Outer Dimension.....	13
3.4.2 Mount and Use	14
3.5 Connection	15
3.5.1 Typical cable connection	16
3.5.2 Connection to the Controller.....	17
3.6 Power Supply	18
4. Operation Mode (TEACH, AUTO, TEST)	19
4.1 Outline.....	19
4.2 Switching Operation Mode.....	21
5. Operation Panel (Key Description)	22
5.1 Key Description.....	22
6. Enable Switch	25
7. Warning Sound (Beep)	25

Operation

1. Teaching Procedure	29
1.1 Jog Operation	29
1.2 Teaching	30
1.3 Direct Teaching.....	31
2. TEACH Mode	33
2.1 Jog & Teach.....	34
2.1.1 Specifying Point Number.....	34
2.1.2 Specifying Jog Mode	34
2.1.3 Specifying Jog Speed.....	35
2.1.4 Jog key	35
2.1.5 Executing Step Jog	36
2.1.6 Executing Continuous Jog	36
2.1.7 ON/OFF	36
2.1.8 Motor ON/OFF	37
2.1.9 Executing Return to Home	37
2.1.10 Teaching.....	38
2.1.11 Saving Point File	39
2.1.12 Loading Point File.....	40
2.2 Switch to TEST mode.....	40
2.3 Robot	41
2.3.1 Changing Robot Number	41
2.3.2 Changing the numbers of Arm, Tool, Local, ECP.....	41
2.4 Motion Command	42
2.4.1 6-Axis robots.....	42
2.4.2 Robots except 6-Axis robots	43
2.5 I/O Command	44
2.5.1 Switching Input/Output Status Display.....	44
2.5.2 Output Bit ON/OFF	44
2.6 Jog Distance	45
2.6.1 Changing Jog Distance	45
2.6.2 Default	45
2.7 Point Editor	46
2.7.1 Specifying Point Number.....	46
2.7.2 Changing Point Label.....	46
2.7.3 Changing Coordinate Data and Pose Flag	47
2.7.4 Deleting Point Data	47

2.8 Brake (6-Axis robots only)	48
3. AUTO Mode	50
3.1 Program Command Display.....	51
3.2 I/O Monitor	52
3.3 Memory I/O Monitor	52
3.4 Task Monitor	53
3.5 System History.....	54
3.6 Speed Factor	55
3.7 Date / Time.....	56
3.8 Brightness / Contrast	56
3.9 Language	57
3.10 Error	57
4. TEST mode	58
4.1 Single-task program verification	59
4.2 Multi-task Program Verification.....	62
4.3 Test mode	64
4.4 Function	65
4.5 Program List Display.....	66
4.6 Program Verification	67
4.6.1 Single-task program verification screen	67
4.6.2 Multi-task program verification screen	69
4.6.3 Continue	69
4.6.4 Step In.....	69
4.6.5 Step Out.....	70
4.6.6 Walk.....	70
4.6.7 Run Window (TEST mode)	70
4.6.8 I/O monitor (TEST mode).....	71
4.6.9 Variables (TEST mode).....	72
4.6.10 Task Manager (TEST mode).....	72
4.7 Error	73
5. Password Setup	74
6. Troubleshooting	75
7. Maintenance Parts List	76
8. Option Parts List	76



Functions & Installation

This section contains information about functions and installation of the Teach Pendant to be known before operation and maintenance.

1. Safety

1.1 Conventions

Important safety considerations are indicated throughout the manual by the following symbols. Be sure to read the descriptions shown with each symbol.

 WARNING	This symbol indicates that a danger of possible serious injury or death exists if the associated instructions are not followed properly.
 WARNING	This symbol indicates that a danger of possible harm to people caused by electric shock exists if the associated instructions are not followed properly.
 CAUTION	This symbol indicates that a danger of possible harm to people or physical damage to equipment and facilities exists if the associated instructions are not followed properly.

1.2 Safety Precautions

For details of Safety, refer to *Safety Manual*. Please read and understand the chapter before using the robot system.

 WARNING	<ul style="list-style-type: none"> ■ The robot system should be designed and installed by personnel who has taken robot system training held by us and suppliers. ■ Only qualified personnel who have taken the safety training should be allowed to execute teaching or calibration of the robot system. The safety training is the program for industrial robot operator that follows the laws and regulations of each nation. The personnel who have taken the safety training acquire knowledge of industrial robots (operations, teaching, etc.). The personnel who have completed the robot system-training class held by the manufacturer, dealer, or locally-incorporated company are allowed to maintain the robot system. ■ Only personnel who has taken maintenance training held by us and suppliers should be allowed to perform the maintenance of robot system.
--	---

 <p>WARNING</p>	<ul style="list-style-type: none">■ Immediately press the EMERGENCY STOP switch whenever you suspect any danger. The Teach Pendant is equipped with an EMERGENCY STOP switch. Before operating the Teach Pendant, make sure that the EMERGENCY STOP switch on the Teach Pendant functions properly. Operating the Teach Pendant when the switch does not function properly is extremely hazardous and may result in serious bodily injury and/or serious damage to the equipment, as the switch cannot fulfill its intended function in an emergency. When nothing appears on its display window, the Teach Pendant is not connected with the Controller. In this case, the EMERGENCY STOP switch on the Teach Pendant will not function.■ If the Teach Pendant is not connected to the controller, DO NOT place it within easy reach during operation. You might press the EMERGENCY STOP switch on the unconnected Teach Pendant by mistake to stop the robot system in an emergency. Pressing the EMERGENCY STOP switch on the disconnected Teach Pendant in an emergency is extremely hazardous and may cause serious safety problems.■ When entering the safeguarded area for teaching, change the mode of the Teach Pendant to TEACH and take out the key for the mode selector key switch and then enter the safeguarded area with the key. Leaving the key in the mode selector key switch is extremely hazardous and may cause serious safety problems as someone else may inadvertently change the mode to the automatic operation.
--	---

 <p>WARNING</p>	<ul style="list-style-type: none">■ Be sure to connect the cables between the Controller and the Teach Pendant properly. Do not allow unnecessary strain on the cables. (Do not put heavy objects on the cables. Do not bend or pull the cables forcibly.) The unnecessary strain on the cables may result in damage to the cables, disconnection, and/or contact failure. Damaged cables, disconnection, or contact failure is extremely hazardous and may result in electric shock and/or improper function of the system. Do not use the cables near heat or fire.
--	---

 CAUTION	<ul style="list-style-type: none"> ■ Do not shock the Teach Pendant physically or place any object on Teach Pendant. A liquid crystal display is used for the Teach Pendant display. If the display is damaged, liquid crystal may leak out. Liquid crystal is harmful. If it sticks on your skin or clothes, immediately wash your skin and clothes thoroughly with clean water and soap immediately. ■ The Teach Pendant must be used within the environmental conditions described in this manual. This product has been designed and manufactured strictly for use in a normal indoor environment. Using this product in the environment that exceeds the conditions may not only shorten the life cycle of the product but also cause serious safety problems. ■ Do not disassemble, repair, or modify the Teach Pendant by yourself. Improper disassembly, repair, or modification of the Teach Pendant may cause not only improper function of the robot system but also serious safety problems.
---	---

Safety-related Requirements

Specific tolerances and operating conditions for safety are contained in the manuals for the robot, controller and other devices. Be sure to read those manuals as well.

Robot systems safety standard and other examples are given in this chapter. Therefore, to ensure that safety measures are complete, please refer to the other standards listed as well.

(Note: The following is only a partial list of the necessary safety standards.)

ISO 10218-1	Robots and robotic devices -- Safety requirements for industrial robots -- Part 1: Robots
ISO 10218-2	Robots and robotic devices -- Safety requirements for industrial robots -- Part 2: Robot systems and integration
ANSI/RIA R15.06	American National Standard for Industrial Robots and Robot Systems -- Safety Requirements
ISO 12100	Safety of machinery -- General principles for design -- Risk assessment and risk reduction
ISO 13849-1	Safety of machinery -- Safety-related parts of control systems -- Part 1: General principles for design
ISO 13850	Safety of machinery -- Emergency stop function -- Principles for design
ISO 13855	Safety of machinery -- Positioning of safeguards with respect to the approach speeds of parts of the human body.
ISO 13857	Safety of machinery -- Safety distances to prevent hazard zones being reached by upper and lower limbs.
ISO 14120	Safety of machinery -- Guards -- General requirements for the design and construction of fixed and movable guards
IEC 60204-1	Safety of machinery -- Electrical equipment of machines -- Part 1: General requirements
CISPR11	Industrial, scientific and medical (ISM) radio-frequency equipment -- Electromagnetic disturbance characteristics -- Limits and methods of measurement
IEC 61000-6-2	Electromagnetic compatibility (EMC) -- Part 6-2: Generic standards -- Immunity for industrial environments

1.3 EMERGENCY STOP



- Immediately press the Emergency Stop switch whenever you suspect any danger. The Teach Pendant is equipped with an Emergency Stop switch. Before operating the Teach Pendant, make sure that the Emergency Stop switch on the Teach Pendant functions properly. Operating the Teach Pendant when the switch does not function properly is extremely hazardous and may result in serious bodily injury and/or serious damage to the equipment, as the switch cannot fulfill its intended function in an emergency.
- When nothing appears on its display window, the Teach Pendant is not connected with the Controller. In this case, the Emergency Stop switch on the Teach Pendant will not function.

When the Emergency Stop switch is pushed, stops the programs execution and halts the robot excitation. Programs and point data will not be damaged.

When pushed, the Emergency Stop switch mechanically holds that state and electrically holds the emergency stop state.

Reset EMERGENCY STOP

Follow these steps to reset Emergency Stop condition.

- (1) Remove the cause of the Emergency Stop and verify that it is safe to operate the robot again.
- (2) Release the Emergency Stop switch. To release the mechanical latch, turn the Emergency Stop switch to the right.
- (3) Turn the Teach Pendant mode selector key switch to “Teach”.
- (4) Press the <Reset> key on the operation panel to reset the Emergency Stop.
- (5) Make sure that the E-Stop lamp on the operation panel is OFF.

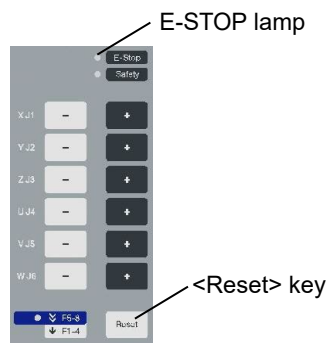

1.4 Mode Selector Key Switch

The mode selector key switch is used to select TEACH or AUTO operation mode. For safety, if the mode is changed during program execution, all tasks will be stopped.

To change to TEST mode, switch the mode selector key switch to TEACH, and then select Function key F1: Test Mode.

Mode switching during task execution

AUTO → TEACH

- (1) Press the <Stop> button of EPSON RC+ to stop all tasks normally.
- (2) Turn the mode selector key switch to “Teach”.

TEACH → AUTO

Turn the mode selector key switch to “Auto” and close the latch release input.

Use a latch release input signal to release the latched status.

NOTE



The TEACH mode status is latched by software.

To switch the mode from TEACH to AUTO, release the latched condition using the latch release input signal.

1.5 Using Teach Pendant in Safeguarded Area

When the mode selector switch of the Teach Pendant is switched to “Teach” mode, the operator can jog and move the robot to predefined points in slow speed while the Enable Switch is held down and the safeguard is open.

When the mode is switched to “Test”, the operator can verify a program while the Enable Switch is held down and the safeguard is open.

Person who will be using the Teach Pendant should be thoroughly trained on how to use it.

Follow the guidelines below when using the Teach Pendant in the safeguarded area:

- (1) Before entering the safeguarded area to use the Teach Pendant, turn the mode selector key switch to “Teach”.
- (2) Enter the safeguarded area. Perform teaching operations and verify a program in Test mode.

NOTE



The TEACH mode status is latched by software.

- (3) Leave the safeguarded area and close the safeguard.
- (4) Return the mode selector key switch to “Auto”.
- (5) Close the latch release input.

For details on the pin assignments of the EMERGENCY connector, refer to

RC700 Series MANUAL

RC90 Series MANUAL

T Series MANUAL

VT Series Manual

NOTE



To switch the mode from TEACH to AUTO, release the latched condition using the latch release input.



CAUTION

- Although the Teach Pendant can be operated inside the safeguarded area as described above, operate the robot system while all operators are outside of the safeguarded area wherever possible.

2. Specifications

2.1 Part Names and Functions

Front view

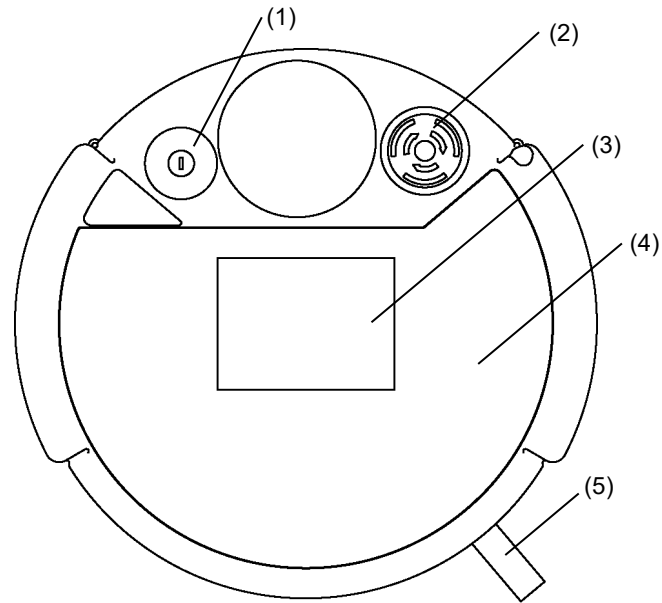

Back view

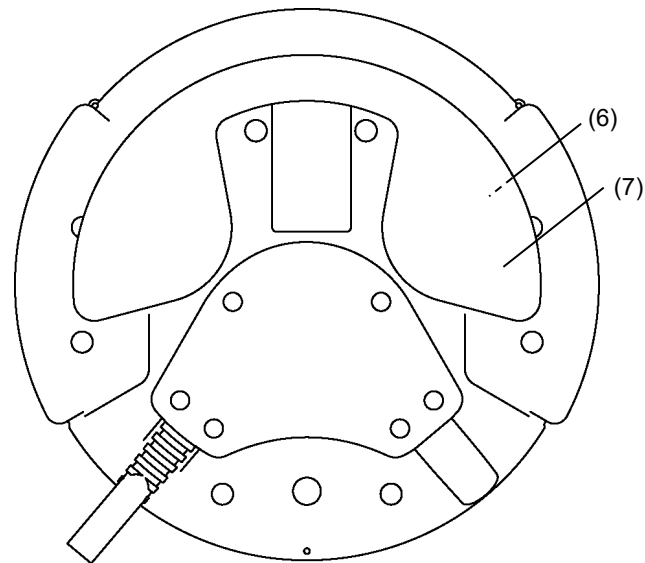

(1) Mode Selector Key switch

The mode selector key switch is used to change the operation mode between TEACH and AUTO. The mode can be fixed by pulling out the key. When the mode is switched while a program is executing, the program will be stopped.

Close the latch when switching the mode from TEACH to AUTO.

To change to TEST mode, switch the mode selector key switch to TEACH, and then select Function key F1: Test Mode.

For the procedure to switch the mode, refer to *Setup & Operation 1.4 Mode Selector Key Switch*.

(2) EMERGENCY STOP switch

When this switch is pushed, the Emergency Stop state is held both mechanically and electrically. Pushing the switch stops the program, removes power to robot motors and stops the manipulator motion immediately.

To cancel the Emergency Stop state, first turn the EMERGENCY STOP switch to the right to release the mechanical latch. Switch the mode selector key switch to "Teach". Press the <Reset> key to reset the electrically held Emergency Stop state. The E-STOP lamp goes OFF.

For the procedure to reset the EMERGENCY STOP switch, refer to *Setup & Operation 1.3 EMERGENCY STOP*.

(3) Display

Displays various kinds of information.

(4) Operation Panel

Teaching operation, automatic operation and data input are available.

(5) Connection Cable

This is a cable to connect the Teach Pendant and the Controller.

The connector is attached at the end of the cable.

(6) Enable switch

This is a three-position switch. Motion and I/O output commands are available while the switch is gripped when the Teach Pendant is operated in TEACH mode. The switch turns ON when it is at the midpoint, and it turns OFF when it is fully gripped or released.

(7) Handle

Use this part as the hand strap while operating the Teach Pendant.

2.2 Standard Specifications

Item		Specification
General specifications	Rated voltage	24 VDC
	Electric power consumption	6 W or less
	Weight	1075 g (include EMERGANCY STOP switch and the mode selector key switch, excluding cables)
Display specifications	Display element	F-STN type Black and white LCD
	Contrast	8-level (Gray scale)
	Back light	LED (Color : White)
Serial interface specifications	Electrical characteristics	Compliant with RS-422A standard

2.3 Outer Dimensions

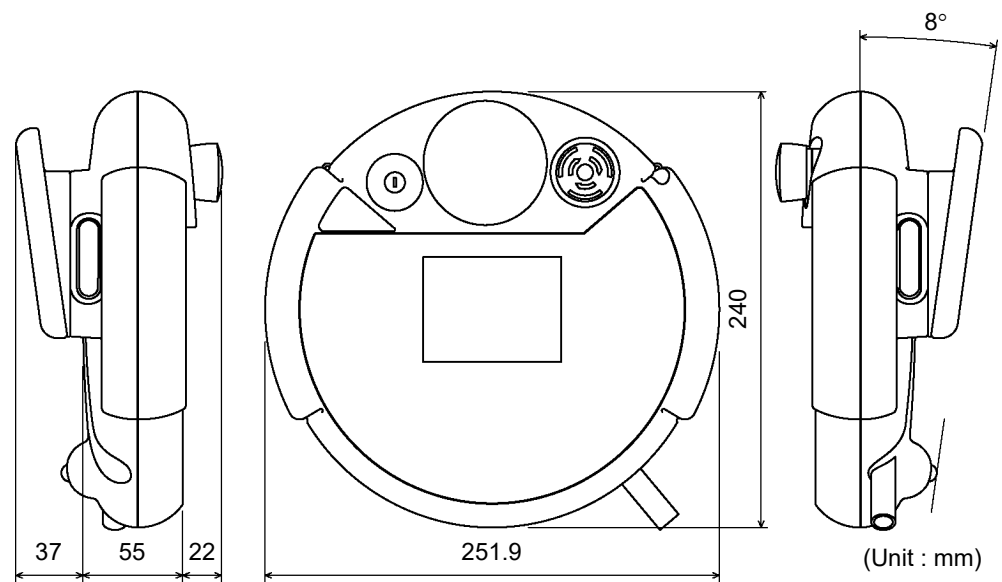

NOTE

Use the installation metal in the attachment when attaching the Teach Pendant to a panel, or the like.

3. Installation

3.1 Contents

- TP1 (with cables) : 1 unit
- Mode selector key : 2 units

3.2 Environmental Conditions

The Teach Pendant must be used in an environment that conforms to the following requirements to ensure safe and reliable operation.

Item	Condition
Ambient temperature	0 to 50 deg C (with minimal variation)
Ambient relative temperature	5 to 95%
Protection structure	IP65 (excluding the connector)
Environment	- Keep away from dust, oily smoke, salinity, metal powder and other contaminants. - Keep away from flammable or corrosive solvents and gases.

3.3 Operating Precautions

 CAUTION	<ul style="list-style-type: none"> ■ Do not drop the Teach Pendant or hit hard against other objects to avoid damage, as the case of the Teach Pendant may be damaged since the main body is made of resin. ■ Do not hit the touch panel of the Teach Pendant against a hard object or put excessive pressure on it. The touch panel is made of glass. Therefore, if excessive pressure is put on it, it may be damaged. ■ Do not press or rub the surface of the front panel push buttons with a hard object such as a tool. The surface of the buttons may be damaged as they are easily scratched. ■ Wipe the dirt and oils adhering to the surface of the Teach Pendant display with a soft cloth dampened with a neutral detergent or an alcohol solvent.
--	--

3.4 Wall Bracket (Option)

3.4.1 Outer Dimension

[Unit :mm]

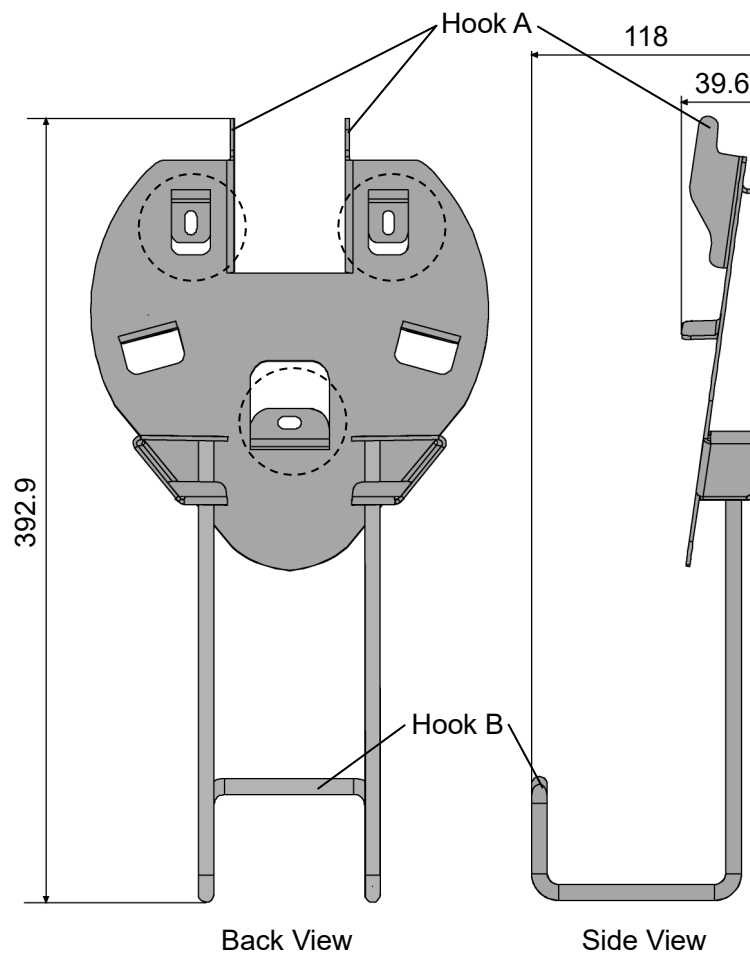
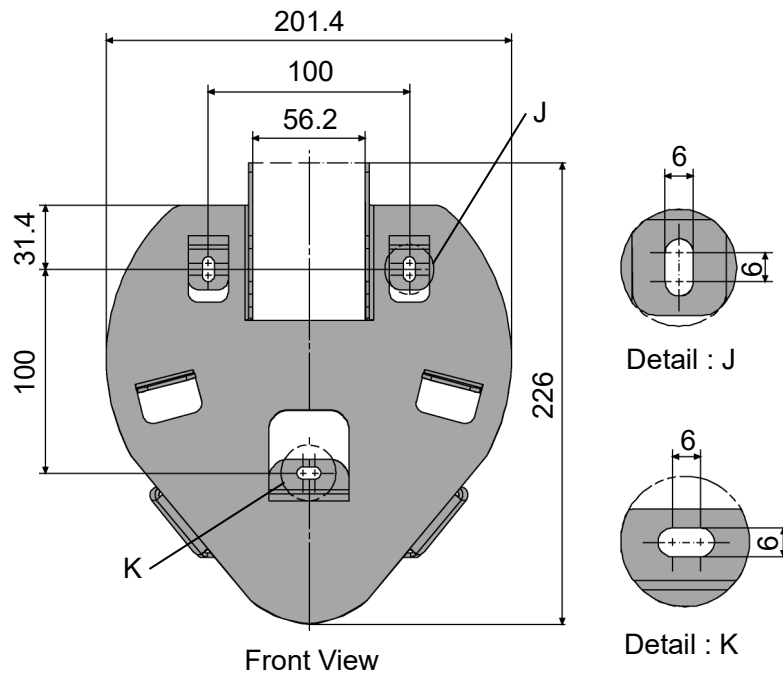

3.4.2 Mount and Use

Mount the Teach Pendant with the wall bracket in the following procedures.

- (1) Secure the wall bracket to the wall with three screws (positions are indicated by dotted line in the *Outer Dimension*).
- (2) Hang the handle of the Teach Pendant to Hook A.
- (3) Hang the cable of the Teach Pendant to Hook B.

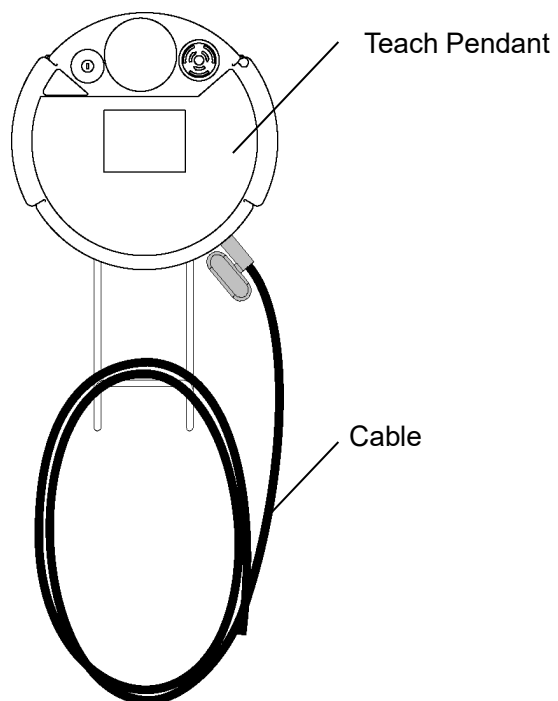

3.5 Connection

This section indicates the connection of the Controller and the Teach Pendant.



CAUTION

- Be sure to connect the cables of Controller and Teach Pendant properly. Do not allow unnecessary strain on the cables. (Do not put heavy objects on the cables. Do not bend or pull the cables forcibly.) The unnecessary strain on the cables may result in damage to the cables, disconnection, and/or contact failure. Damaged cables, disconnection, or contact failure is extremely hazardous and may result in improper function of the system.
- Make sure that the pins are not bent when connecting the connector. Connecting the connector with the pin bent may cause malfunction and result in improper function of the system.
- The connector connected to the end of the cable is a general-purpose type connector. When connecting the connector, note that the waterproof efficiency and dustproof efficiency of the connector do not comply with IP65.
- When connecting the Teach Pendant TP1 to the TP port, be careful of the connector inserting direction (up/down). It may cause malfunction and result in improper function of the system.

3.5.1 Typical cable connection

The Teach Pendant is connected to TP port of controller.



When nothing is connected to the TP port, Emergency Stop status occurs to the Controller. When the Teach Pendant or the Operator Panel is not connected, connect the TP/OP bypass plug.

Example

A: RC90-B, RC700

(1) TP Cable A

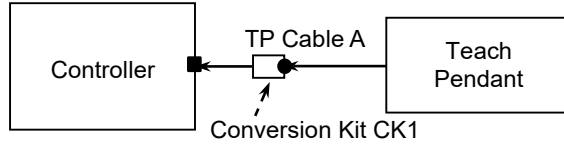

(2) TP Cable B

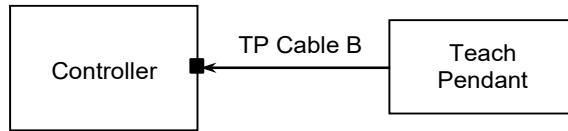

B: RC700-A

(1) TP Cable A

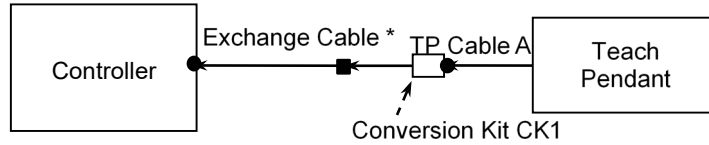

(2) TP Cable B

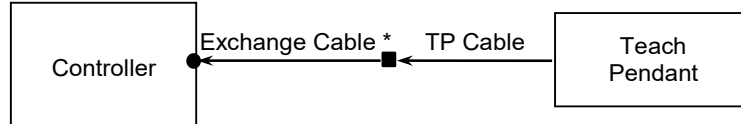

- The shape of the cable connector used in connection A differs to connection B.
 TP Cable A : Direct connection is available with conversion kit CK1.
 TP Cable B : D-sub connector to connect directly to the Controller.
- When connecting TP1 to RC700-A, the RC700-A conversion cable is necessary. If you need the conversion cable, please contact the supplier of your region.

* RC700-A TP Exchange Cable : R12NZ900L6

- Do not connect TP1 to the following Robot Controllers. Connecting to the following Robot Controllers may result in malfunction of the device since the pin assignments are different.
 RC420 / RC520 / SRC5** / SRC-3** / SRC-2**

- Operation of RC700 / RC90 option TP1 differs from the descriptions in this manual when it is connected to the Robot Controllers RC180, RC170, or RC620.

In this case, refer to the following manuals.

When connecting TP1 to the Robot Controller RC180/RC170:

RC170 / RC180 option Teach Pendant TP1 manual

When connecting TP1 to the Robot Controller RC620:

Robot Controller RC620 -14. Option : Teach pendant TP1

- TP1 cannot to be connected to the RC700-E Controller. If it connected to them, an error occurs.

3.5.2 Connection to the Controller

- (1) Check that the Controller and the robot are connected properly.
- (2) Connect the connector of the Teach Pendant cable to the TP port of Controller.
- (3) Turn ON the controller.

NOTE



Teach Pendant can be inserted and removed from the Controller when the Controller power is ON.

- When Teach Pendant connector is removed from the Controller with the mode selector key switch of Teach Pendant that is in “Teach” position, the operation mode will remain in TEACH mode. The operation mode cannot be switched to AUTO mode. Make sure to remove the Teach Pendant after switching the operation mode to “Auto” mode.

3.6 Power Supply

The power of the Teach Pendant is supplied via the TP connector on the Controller. After completing the Controller and the Teach Pendant communication, the following screen will appear on the display of the Teach Pendant.

TEACH mode

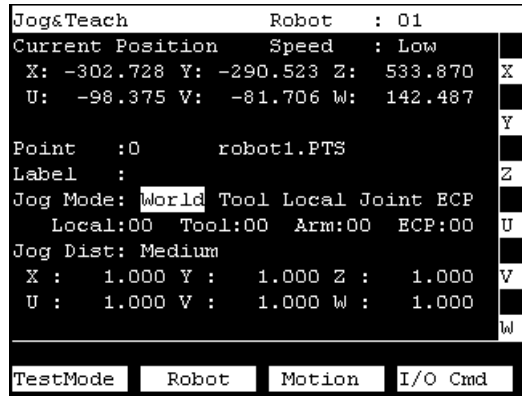

AUTO mode

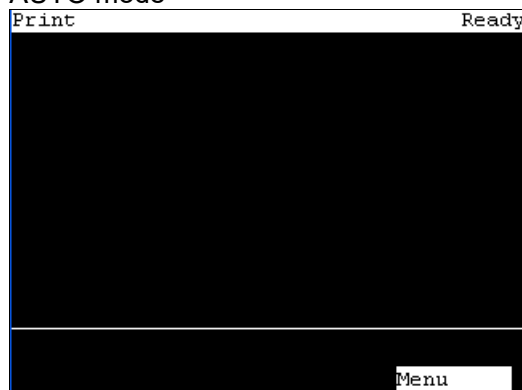

4. Operation Mode (TEACH, AUTO, TEST)

 NOTE A coordinate point including the arm pose is defined as “position (point),” and the data is called “point data.”

4.1 Outline

Robot system has two operation modes: TEACH, AUTO, and TEST modes.

TEACH mode	<p>This mode enables point data teaching and check close from the Robot using the Teach Pendant.</p> <p>Robot operates in Low power status.</p>
AUTO mode	<p>This mode enables automatic operation (program execution) of the Robot system at the manufacture operation, besides, programming, debug, adjustment, and maintenance of the Robot system.</p> <p>This mode cannot operate Robots or run program with the Safety Door open.</p>
TEST mode	<p>This mode enables program verification while the Enable Switch is held down and the safeguard is open.</p> <p>This is a low speed program verification function (T1: manual deceleration mode) which is defined in Safety Standards.</p> <p>This mode can operate the specified Function with multi-task / single-task, multi-manipulator / single-manipulator at low speed.</p>

 NOTE This product does not support a high-speed program verification function (T2: manual acceleration mode) defined in Safety Standards.

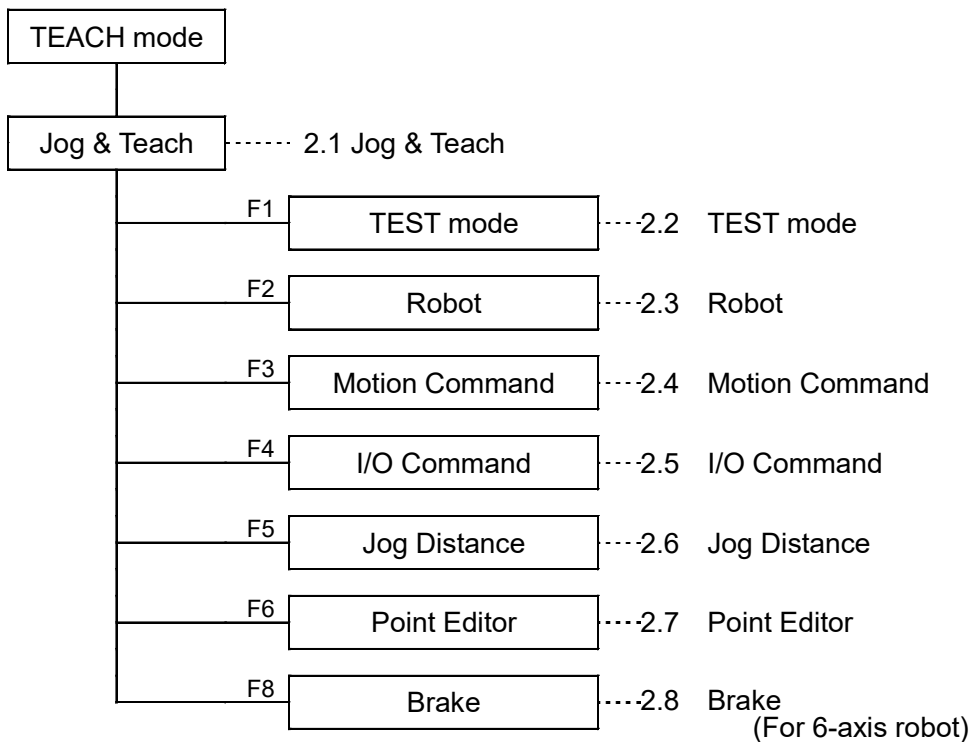

F1-F8 : Function key
 [] : Screen name
 : Reference section

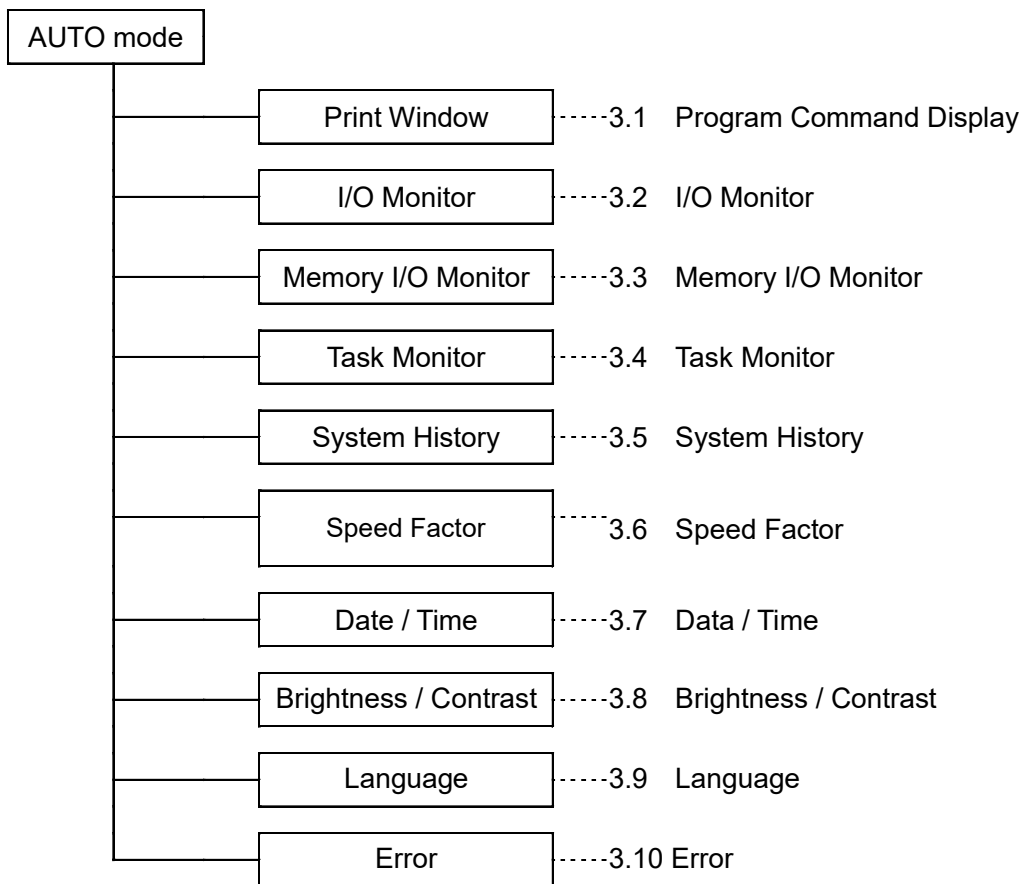

[] : Screen name
 : Reference section

4.2 Switching Operation Mode

Change the TEACH mode and AUTO mode with the mode selector key switch on the Teach Pendant.

To change to TEST operation mode, switch the mode selector to TEACH, and then select Function key F1: Test Mode.

TEACH mode	Turn the mode selector key switch to “Teach” for TEACH mode. Pauses the executing program when operation mode is switched to TEACH mode. The operating Robot stops by Quick Pause.
AUTO mode	Turn the mode selector key switch to “Auto” and change the latch release input signal to ON position for AUTO mode.
TEST mode	Turn the mode selector key switch to “Teach” for “TEACH” mode. Push <F1> key-[Test Mode] in [Jog & Teach] dialog of TEACH mode. The mode will be changed to TEST

NOTE



The TEACH mode status is latched by software.

To switch the mode from TEACH to AUTO, release the latched condition using the latch release input.

The message “Make sure that no one is inside the safeguarded area”. Ensure safety when working.

For details on how to release latch, refer to

RC700 Series MANUAL

RC90 Series MANUAL

T Series MANUAL

VT Series Manual

NOTE



When the mode is switched with the mode switching key switch, the motor is turned OFF.

NOTE



Turn OFF enable switch, when you switch the mode with the mode switching key switch. If the mode is switched with the mode switching key switch while the enable switch is turned ON, and the motor is turned ON, an error will occur. Be sure to turn the enable switch OFF once and then ON again before turning the motor ON.

5. Operation Panel (Key Description)

5.1 Key Description

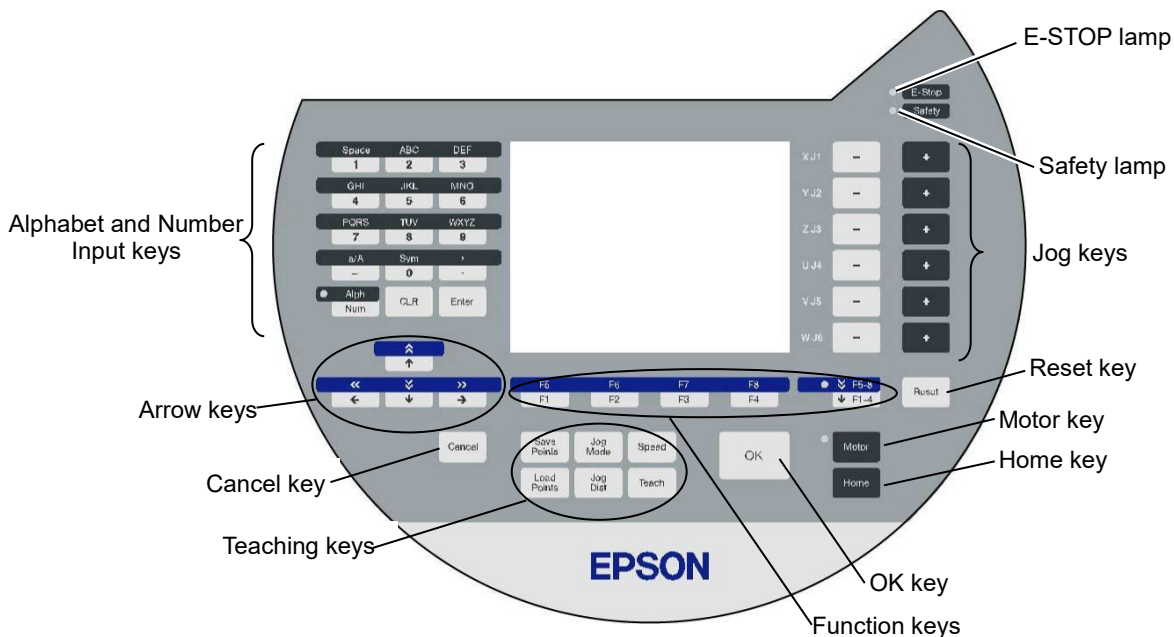

Alphabet and Number Input Keys

Input mode alphabet/number switches by turning ON/OFF the “Alph” lamp.
 Press the <Alph/Num> key to turn ON/OFF the “Alph” lamp.

Alph	Mode	Key	Function
OFF	Number input mode	From 0 to 9 - (minus) . (period)	Number input
ON	Alphabet input mode	ABC to WXYZ	Alphabet input
		SP (space)	Space input
		a/A	Case selector
		Sym	Symbol input
Common		CLR	Clear number and alphabet
Common		Enter	Set number and alphabet

Arrow Keys

Mode switches by turning ON/OFF the “F5-8” lamp.

Press the <F1-4 / F5-8> key to turn ON/OFF the “F5-8” lamp.

F5-8	Mode	Key	Function
OFF	Normal mode	↑	+1 the value Move the cursor up
		↓	-1 the value Move the cursor down
		←	Move the cursor to the left
		→	Move the cursor to the right
ON	Scroll mode	^	+10 the value Move to previous page
		v	-10 the value Move to next page

Function Keys

Press the <F5-8> key to turn ON/OFF the “F5-8” lamp. The display changes.

Example : Jog&Teach Screen

“F5-8” OFF

```

Jog&Teach          Robot : 01
Current Position   Speed : Low
X: -302.728 Y: -290.523 Z: 533.870
U: -98.375 V: -81.706 W: 142.487

Point :0          robot1.PTS
Label :
Jog Mode: World  Tool Local Joint ECP
Local:00 Tool:00 Arm:00 ECP:00
Jog Dist: Medium
X : 1.000 Y : 1.000 Z : 1.000
U : 1.000 V : 1.000 W : 1.000

<F1> <F2> <F3> <F4>
TestMode Robot Motion I/O Cmd
    
```

“F5-8” ON

```

Jog&Teach          Robot : 01
Current Position   Speed : Low
X: -302.728 Y: -290.523 Z: 533.870
U: -98.375 V: -81.706 W: 142.487

Point :0          robot1.PTS
Label :
Jog Mode: World  Tool Local Joint ECP
Local:00 Tool:00 Arm:00 ECP:00
Jog Dist: Medium
X : 1.000 Y : 1.000 Z : 1.000
U : 1.000 V : 1.000 W : 1.000

<F5> <F6> <F7> <F8>
Edit Dist Edit Pnt Brake
    
```

NOTE



Example: Press the <F3> key to display the Motion screen.

When a function key is not assigned to a screen, the key is invalid. Example: <F7>

Jog Keys

Jog key is available only in TEACH mode.

Key	Function
-	Move the target joint (X to W, J1 to J6) to - direction
+	Move the target joint (X to W, J1 to J6) to + direction

Teaching Keys

Teaching key is available only in TEACH mode.

Key	Function
Save Points	Save the point data to a file
Load Points	Read the point data from a file
Jog Mode	Specify the Jog mode
Jog Dist	Specify the Jog distance
Speed	Specify the Jog speed
Teach	Save the current position data

Other Keys

Key	Function
Cancel	Cancel the setting and go back to the previous screen
OK	Save the setting and move on to the next screen
Reset	Set the initial setup status
Motor*	Switch the motor power ON/OFF
Home*	Move the robot to home position

* Keys with this mark are available only in TEACH mode.

Lamp

Lamp	Function
E-Stop	Turns ON when the EMERGENCY STOP switch is pressed
Safety	Turns ON when the safeguard is open

6. Enable Switch

In TEACH mode, several operations require use of the 3-position enable switch located on the left rear of the pendant. The enable switch can be operated either hand.

When operation of the enable switch is required, grip either switch to the center position (ON state). If you grip the switch harder, it will be OFF state and the robot will stop.

Enable Switch (for Left Hand)

Enable Switch (for Right Hand)

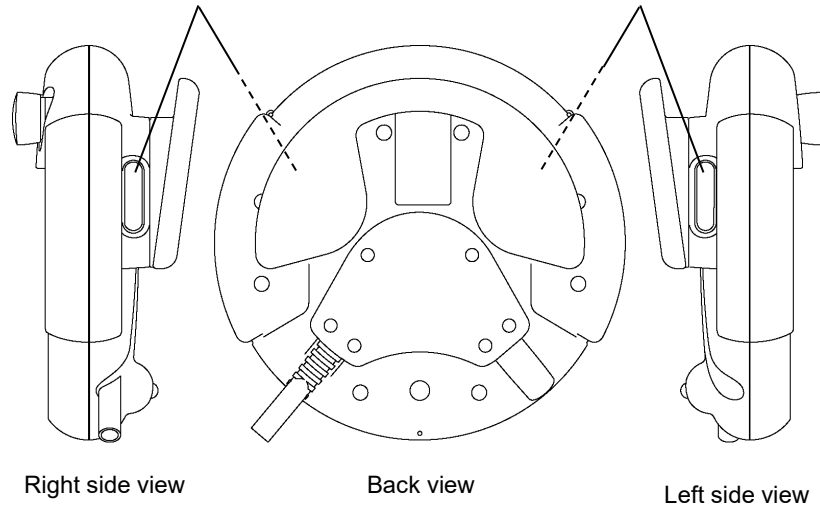

How to press the Enable switch

Grip the enable switch by the finger on the hand holding the handler.

Example : When gripping by the left hand

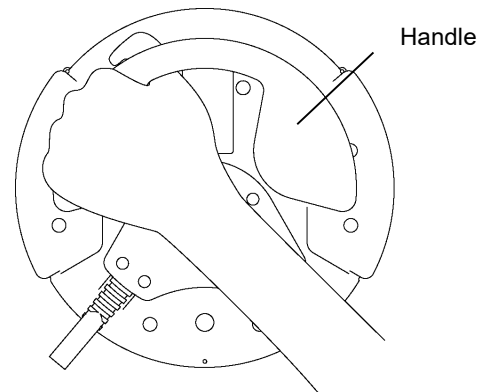

7. Warning Sound (Beep)

The Teach Pendant beeps when the robot passes the singularity.

Operation

This section contains information about operation of the Teach Pendant and maintenance procedure.

1. Teaching Procedure

The basic jog operation and teaching procedure is indicated.

Switch the mode selector switch to “Teach” to display the following screen.

```

Jog&Teach          Robot   : 01
Current Position   Speed   : Low
X: -302.728 Y: -290.523 Z: 533.870
U: -98.375 V: -81.706 W: 142.487

Point   :0          robot1.PTS
Label   :
Jog Mode: World Tool Local Joint ECP
         Local:00 Tool:00 Arm:00 ECP:00
Jog Dist: Medium
X :    1.000 Y :    1.000 Z :    1.000
U :    1.000 V :    1.000 W :    1.000

TestMode  Robot  Motion  I/O Cmd
  
```

NOTE



A coordinate point including the arm pose is defined as “position (point),” and the data is called “point data.”

NOTE



When the robot controller starts up, [Robot] is 01. If you want to change the robot setting, refer to Operation 2.3 Robot.

NOTE



When you switch the mode to “TEACH”, the speed setting of the robot will be the speed (high, low) on the [Jog & Teach] window. Since the motion command will be executed at this speed after the above operation, set the speed again by the commands such as Motor, Speed, and Accel.

1.1 Jog Operation

Move the robot to the teaching position by one of the following operation (Step Jog operation, Continuous Jog operation).

Step Jog Operation

In Step Jog, the robot moves by pressing the Jog key each time.

Jog distance of the robot needs to be configured beforehand.

Press the <Jog Dist> key to specify the [Jog Dist] (Long, Medium, Short).

Execute the step jog by gripping the Enable Switch as pressing the Jog key.

NOTE



[Jog Dist] “User” can be set arbitrarily. Refer to Operation: 2.6 Jog Distance.

Continuous Jog Operation

In Continuous Jog, the robot moves while pressing the Jog key.

Press the <Jog Dist> key to select “Cont Jog” for the [Jog Dist].

The continuous jog can be executed by gripping the enable switch as pressing the Jog key.

NOTE



To execute the continuous jog, press some jog keys at a time. For example, press the <+X> and <+Y> keys together for the continuous jog diagonally.

1.2 Teaching

Apply the robot position to the specified point number.

- (1) Specify the point number by changing the value in the [Point] using the <↑> and <↓> keys.
[Label] display changes by changing the point number.

- (2) Press the <Teach> key. The following screen appears.

```

Teach          Robot   : 01
Ready to assign current position
to point.
Point         :2
Continue?
    
```

When the point number is already used, the following screen appears.

```

Teach          Robot   : 01
Ready to assign current position
to point.
Point         :0
Overwrite?
    
```

- (3) Press the <OK> key to assign the robot position.
- (4) Press the <Save Points> key to display the following screen.

```

Save Points    Robot   : 01
Point File Name:
robot1.PTS
    
```

- (5) Press the <OK> key to save the file.



Press the <Cancel> key to returns to the [Jog & Teach] screen without saving the changes of the file.

1.3 Direct Teaching

“Direct teach” is a way to teach the SCARA robot directly by setting the teaching joint to servo-OFF.

Apply the Robot position to the specified point number.



The 6-axis robot cannot be moved by hand, execute the jog instead.

(1) Specify the point number by changing the value in [Point] using the <↑> and <↓> keys. [Label] display changes by changing the point number.

(2) Press the <Jog Dist> key and specify “Free Joint” for [Jog dist].

Set each joint to servo ON or OFF.

<Jog+> key :Lock :Servo OFF the joint

<Jog-> key :Free :Servo ON the joint

<F2> key :All Lock :Servo OFF all the joint

<F3> key :All Free :Servo ON all the joint

(3) Servo OFF joint can be moved with hands.

(4) Press the <F4> key to display the [Jog & Teach] screen.

(5) Move the Robot arm to the position to teach.

(6) Press the <Teach> key, the following screen appears.

```
Teach          Robot : 01
Ready to assign current position
to point.
Point         :2
Continue?
```

When the point number is already used, the following screen appears.

```
Teach          Robot : 01
Ready to assign current position
to point.
Point         :0
Overwrite?
```

(7) Press the <OK> key to assign the robot position.

- (8) Press the <Save Points> key to display the following screen.

```
Save Points          Robot : 01
Point File Name:
robot1.PTS
```

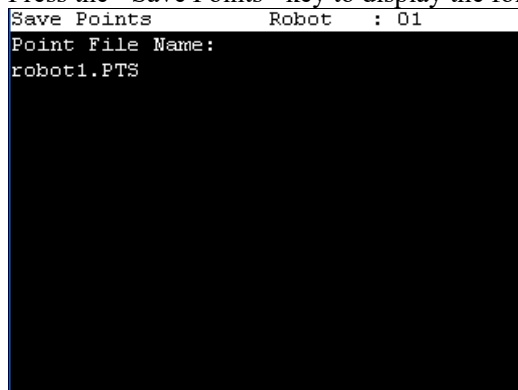

- (9) Press the <OK> key to save the file.



Press the <Cancel> key to return to the [Jog & Teach] screen without saving the changes of the file.

2. TEACH Mode

Switch the mode selector key switch to “Teach” to enter the TEACH mode. In this mode, jog, teaching, operation commands, I/O commands, and other operations and commands can be executed using the Teach Pendant.

By pressing <F1> key, you can switch to TEST mode.

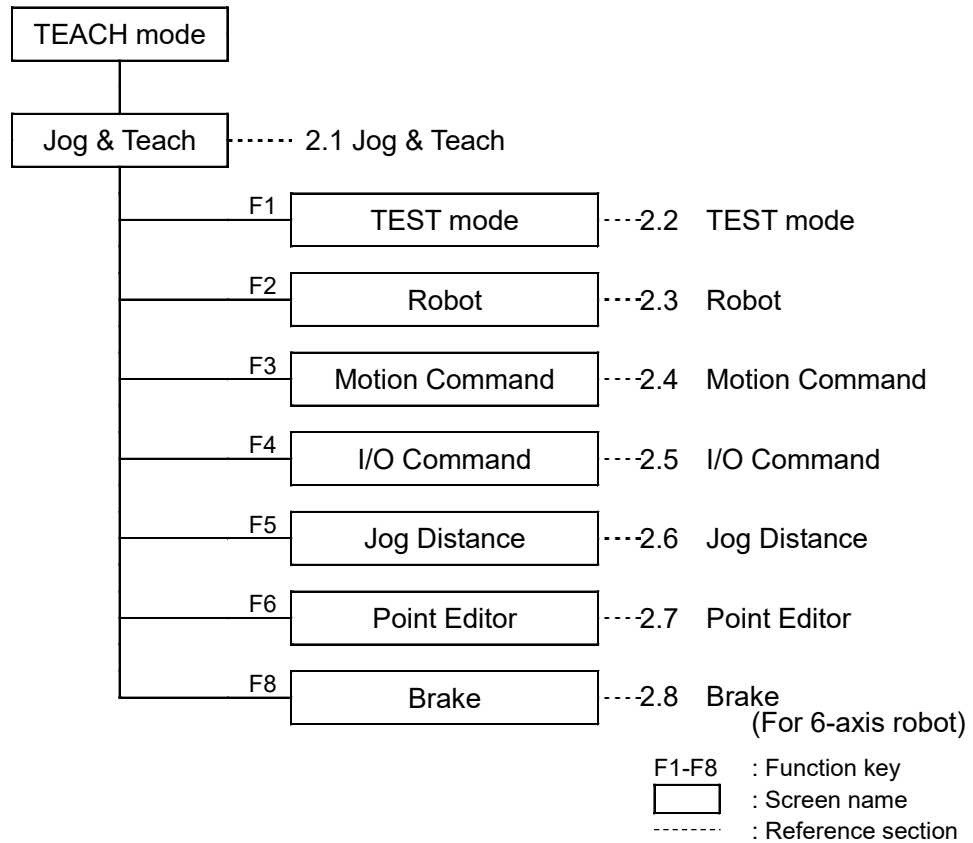

A coordinate point including the arm pose is defined as “position (point),” and the data is called “point data.”

2.1 Jog & Teach

This section indicates settings in the [Jog & Teach] screen.

- Switch the mode selector key switch to “Teach” to display the following screen.

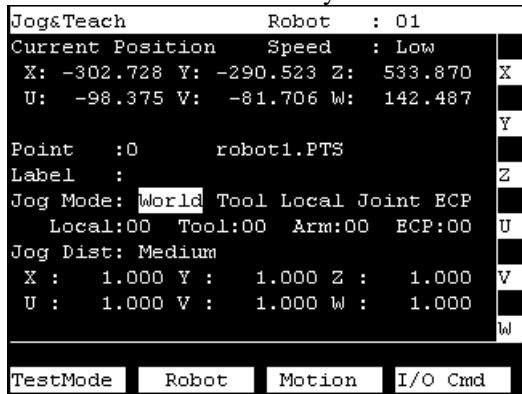

- Set the data items currently displayed in the [Jog & Teach] screen.
 See (described hereinafter) : Specifying Point Number Specifying Jog Mode
 Specifying Jog Speed Jog key
 Executing Step Jog Executing Continuous Jog
- Note down the robot position.
 See (described hereinafter) : Teaching
- Back up the point data to a file.
 See (described hereinafter) : Saving Point File

2.1.1 Specifying Point Number

Change the value at [Point] using the <↑> and <↓> keys to specify a point number.
 Changing the point number changes the indication at [Label].

2.1.2 Specifying Jog Mode

Press the <Jog Mode> key and specify the [Jog Mode]. (World, Tool, Joint, ECP)
 The default setting is “World”.

- World** : Jogs the robot along the X, Y, Z axes in the current local, tool, arm, and ECP.
 For robots with 4 DOF, you can also jog U (roll).
 For robots with 6 DOF, you can jog U (roll), V (pitch), and W (yaw). This is the default setting.
- Tool** : Jogs the robot in the coordinate system defined by the current tool.
- Joint** : Jogs each joint of the robot.
 A separate set of jog buttons will appear when using joint mode when using non-Cartesian robots.
- ECP** : Jogs the robot along the axes of the coordinate system defined by the current external control point. Coordinates are World coordinates.



When the <F5-8> key lights up its LED, the toggle of <Jog Mode> key is the opposite direction.

2.1.3 Specifying Jog Speed

Press the <Speed> key and select the speed at [Speed]. (Low, High)

Low : Low jog speed

High : High jog speed

2.1.4 Jog key

The moving direction or joint is displayed in the left side of the Jog key.

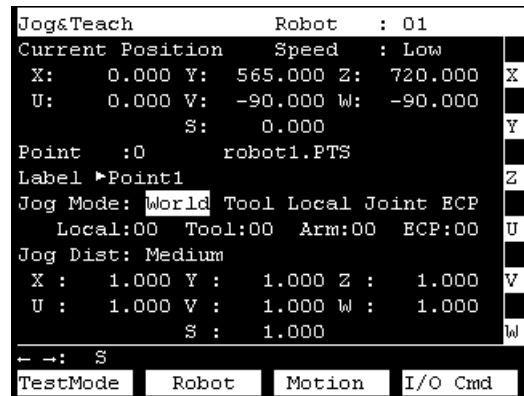

NOTE

If the robot has 6 or more axes, the three keys shown below are switched when pressing the <<> <>> keys.

Example: [U, V, W] → [R, S, T] / [J4, J5, J6] → [J7, J8, J9]

When the additional S axis is set on the 6-axis robot, the key display is changed as shown below to move the additional S axis.

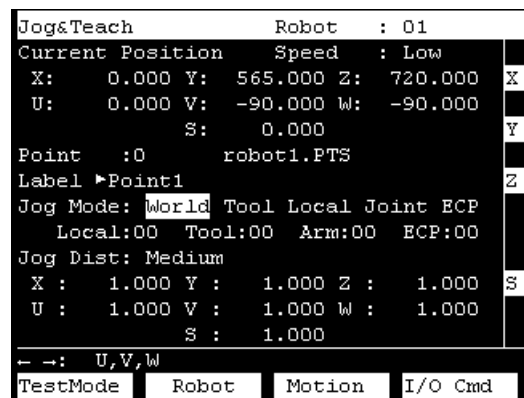

When the Jog keys are not displayed, the robot cannot move by pressing keys.

2.1.5 Executing Step Jog

By step jog operation, the robot moves when the Jog key is pressed.

Set the distance that the robot moves beforehand.

(1) Press the <Jog Dist> key and select the distance at [Jog Dist].

Long : Long jog distance

Medium : Medium jog distance

Short : Short jog distance



NOTE When the <F5-8> key lights up its LED, the toggle of <Jog Dist> key is the opposite direction.

(2) To execute step jog, grip the Jog key with the enable switch held down.

2.1.6 Executing Continuous Jog

With continuous jog, the robot moves continuously while the Jog key is held down.

(1) Press the <Jog Dist> key and select “Cont Jog” at [Jog Dist].



NOTE When the <F5-8> key lights up its LED, the toggle of <Jog Dist> key is the opposite direction.

(2) To execute continuous jog, grip the enable switch while pressing the Jog key.

2.1.7 ON/OFF

Specify On/Off for each joint.

When performing direct teaching (manually moving the robot by hand to perform teaching), set the joint to Off.

Press the <Jog Dist> key and select “Free Joint” for [Jog Dist].

Set On/Off for each joint.

<-> key : Free : Sets the joint to Off.

<+> key : Lock : Sets the joint to On.

<F3> key : Free All : Sets all joints to Off.

<F4> key : Lock All : Sets all joints to On.

2.1.8 Motor ON/OFF

Motor ON

- (1) Press the <Motor> key. The following screen is displayed.

```
Motor          Robot   : 01
Ready to turn robot motors ON.
Continue?
```

Press the <OK> key while holding the enable switch.

Motor OFF

- (1) Press the <Motor> key.

NOTE



Perform the following operations to turn OFF the motor.

- Turn OFF the enable switch
- Switch the mode with the mode switching key switch

NOTE



Turn OFF enable switch, when you switch the mode with the mode switching key switch. If the mode is switched with the mode switching key switch while the enable switch is turned ON, and the motor is turned ON, an error will occur. Be sure to turn the enable switch OFF once and then ON again before turning the motor ON.

TIP



This can be executed at any time in TEACH mode.

2.1.9 Executing Return to Home

Press the <Home> key to return the robot to its home position.

2.1.10 Teaching

The robot position is assigned to the specified point number.

- (1) Press the <Teach> key. The following screen appears.

```
Teach          Robot  : 01
Ready to assign current position
to point.
Point         :2
Continue?
```

When the point number is already used, the following screen appears.

```
Teach          Robot  : 01
Ready to assign current position
to point.
Point         :0
Overwrite?
```

- (2) Press the <OK> key to assign the point data.
- (3) Press the <Save Points> key.



This can also be executed in the [Point Editor] screen.

2.1.11 Saving Point File

- (1) Press the <Save Points> key. The following screen appears.

```
Save Points      Robot   : 01
Point File Name:
robot1.PTS
```

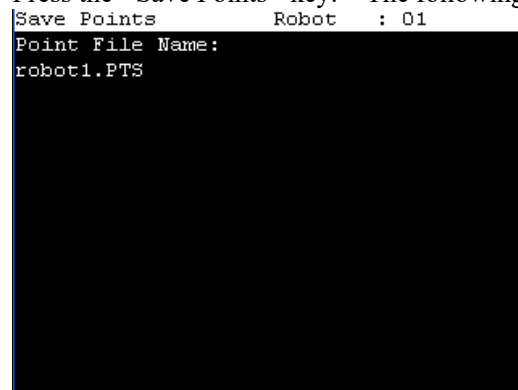
A screenshot of a terminal window showing the 'Save Points' screen. The text displayed is 'Save Points Robot : 01' on the first line, 'Point File Name:' on the second line, and 'robot1.PTS' on the third line. The rest of the screen is black.

- (2) Press the <OK> key to save the positions to the file.



This can also be executed in the [Point Editor] screen.

2.1.12 Loading Point File

- (1) Press the <LoadPoints> key. The following screen appears. Move the cursor to select a file.

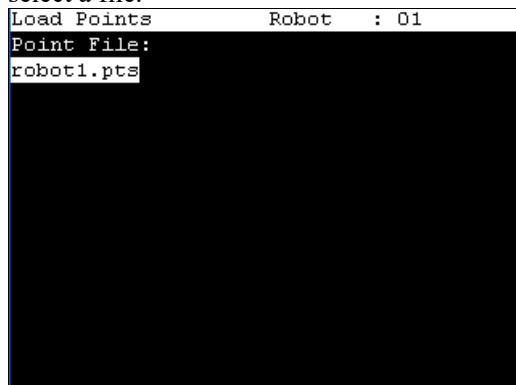

- (2) Press the <OK> key to load the point data in the file memory.



When there is some change in the point file, the following screen appears.



Select whether if you want to save the point file.

- F2 : Save the new settings and load the point file.
- F3 : Destroy the new settings and load the point file.
- Cancel : Return to the previous screen.



This can also be executed in the [Point Editor] screen.

2.2 Switch to TEST mode

This section describes how to switch the mode from TEACH to TEST.

TEST mode enables program verification while the Enable Switch is held down and the safeguard is open.

This is a low speed program verification function (T1: manual deceleration mode) which is defined in Safety Standards. This mode can execute a specified Function with multi-task / single-task, multi-manipulator / single-manipulator at low speed.

For details, refer to *Operation: 4. TEST mode*.

2.3 Robot

This section indicates settings in the [Robot] screen.

Press the <F2> key in the [Jog & Teach] screen. The following screen appears.

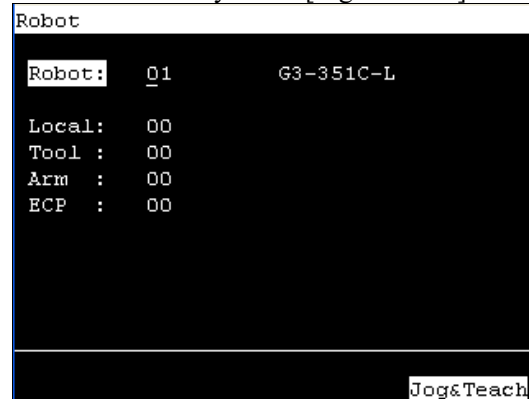

When a value has been changed, press the <Enter> key to apply the value, and be sure to press the <OK> key to save the settings.

2.3.1 Changing Robot Number

- (1) Press the <↑> <↓> keys and move the cursor to [Robot].
- (2) Change the robot number.
- (3) Press the <Enter> key. Robot name will be changed by changing the robot number.
- (4) Press the <OK> key to save the settings.

NOTE



The display of the robot name is changed in the step (3). Save the robot setting before changing the numbers of Arm, Tool, Local, and ECP.

2.3.2 Changing the numbers of Arm, Tool, Local, ECP

NOTE



Set the robot number first and then change the numbers of Arm, Tool, Local, and ECP.

- (1) Press the <↑> <↓> keys and move the cursor to item
- (2) Change the number.
- (3) Press the <Enter> key.
- (4) Press the <OK> key to save the settings.

2.4 Motion Command

2.4.1 6-Axis robots

This item indicates the procedure for executing motion commands when using 6-Axis robots

- (1) Press the <F3> key in the [Jog & Teach] screen. The following screen appears.

Move the cursor to the desired motion command, and press the <OK> key.



- (2) The motion command screen appears.
Set the information required for the motion command, and press the <Enter> key to apply the settings.
- (3) Press the <OK> key to execute the motion command.

NOTE



To execute motion command, grip the enable switch while pressing the <OK> key.

2.4.2 Robots except 6-Axis robots

This item indicates the procedure for executing motion commands when using the robots except the 6-axis robots.

- (1) Press the <F3> key in the [Jog & Teach] screen. The following screen appears.

Move the cursor to the desired motion command, and press the <OK> key.

```
Motion Command      Robot : 01
0 Jump:Z(0)
1 Jump
2 Go
3 Move
4 Arc
5 Arc3
Jog&Teach
```

- (2) The motion command screen appears.
Set the information required for the motion command, and press the <Enter> key to apply the settings.
- (3) Press the <OK> key to execute the motion command.



To execute motion command, grip the enable switch while pressing the <OK> key.

2.5 I/O Command

This section indicates settings in the [I/O Command] screen.

Press the <F4> key in the [Jog & Teach] screen. The following screen appears.

I/O Command		Robot : 01
Inputs		
Bit#	Status	Label
0	On	Sensor1
1	On	Sensor2
2	On	
3	On	
4	On	
5	On	
6	On	
7	On	
		Outputs Jog&Teach

2.5.1 Switching Input/Output Status Display

Press the <F3> key to switch between the “Inputs” status and the “Outputs” status display.

2.5.2 Output Bit ON/OFF

- (1) Press the <F3> key to display the “Outputs” status.

I/O Command		Robot : 01
Outputs		
Bit#	Status	Label
0	Off	Vacuum
1	Off	
2	Off	
3	Off	
4	Off	
5	Off	
6	Off	
7	Off	
ON	OFF	Inputs Jog&Teach

- (2) Move the cursor to the output bit that you want to change.
- (3) Switch the ON/OFF status of the output bit.
 <F1> key: On
 <F2> key: Off

2.6 Jog Distance

This section indicates settings in the [Jog Distance] screen.

Press the <F5> key in the [Jog & Teach] screen. The following screen appears.

```
Jog Distance      Robot : 01
Jog Mode: World Tool Local Joint ECP
Jog Dist: Long Medium Short

X :1.000          [ mm ]
Y :1.000          [ mm ]
Z :1.000          [ mm ]
U :1.000          [ deg ]
V :1.000          [ deg ]
W :1.000          [ deg ]

Default          Jog&Teach
```

When a value has been changed, press the <Enter> key to apply the value, and be sure to press the <OK> key to save the settings.

2.6.1 Changing Jog Distance

Set the jog distance.



- The current jog mode and jog distance are displayed.
- You can change these settings by pressing the <Jog Mode> or <Jog Dist> key.
- When the <F5-8> key lights up its LED, the toggles of <Jog Mode> and <Jog Dist> keys are the opposite direction.

- (1) Press the <↑> <↓> keys and move the cursor to change an item.
- (2) Change the Jog Distance.
- (3) Press the <Enter> key.
- (4) Press the <OK> key to save the settings.

2.6.2 Default

Press the <F1> key to return jog distance data to their defaults.

2.7 Point Editor

This section describes settings in the [Point Editor] screen.

- (1) Press the <F6> key in the [Jog & Teach] screen. The following screen appears.

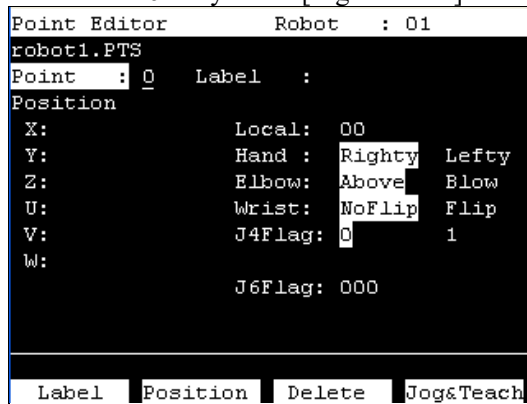

- (2) Set the data items currently displayed in the [Point Editor] screen.
 Refer to : 2.7.1 Specifying Point Number
 2.7.2 Changing Point Label
 2.7.3 Changing Coordinate Data and Pose Flag
 2.7.4 Deleting Point Data
- (3) Note down the robot position.
 Refer to : 2.1.10 Teaching
- (4) Back up the point data to a file.
 Refer to : 2.1.11 Saving Point File

2.7.1 Specifying Point Number

There are two ways to specify the point number.

- (1) Specify the point number by changing the value in the [Point] using the <↑> and <↓> keys.
 Change the point number to change the indication at [Label].
- (2) Change the [Point] values directly and press the <Enter> key.
 Change the point number to change the indication at [Label].

2.7.2 Changing Point Label

- (1) Press the <F1> key and move the cursor to [Label].
- (2) Enter the label name at [Label] to set the name.
- (3) Press the <Enter> key.
- (4) Press the <OK> key to apply the memory.

2.7.3 Changing Coordinate Data and Pose Flag

- (1) Press the <F2> key and move the cursor to [Position: X].
- (2) Move the cursor, and set the coordinate data/pose flag.



TIP To change the orientation flag, point to the orientation flag and press the <F2> key.

- (3) Press the <OK> key to apply the memory.

2.7.4 Deleting Point Data

Press the <F3> key to delete the point data.

2.8 Brake (6-Axis robots only)

This section indicates the brake ON / OFF switching for each joint.



When you use the 6-axis robot, the <F8> key is displayed.

- (1) Press the <F8> key in the [Jog & Teach] screen. The following screen appears.

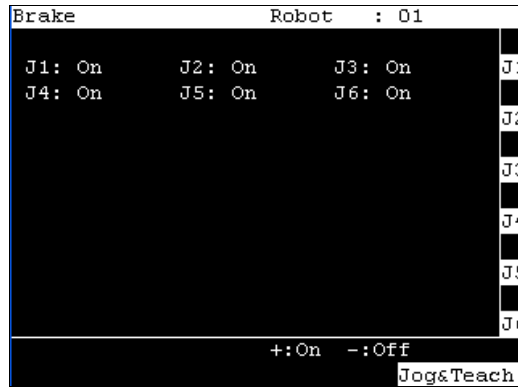

The following screen appears when the password is set up.

Enter the password (1 to 16 characters) and press the <OK> key.



For password setting, refer to *Operation 5. Password Setup*.

To turn the brake ON

- (2) Press the <Jog+> key of the joint whose brake On/Off setting is to be switched.
- (3) Press the <OK> key. The brake is locked.

To turn the brake OFF

- (2) Press the <Jog-> key of the joint whose brake On/Off setting is to be switched.
- (3) The brake Off confirmation message appears. Confirm the message and press the <F1> key.

```
Brake Robot : 01
Warning:
BRAKE OFF can be cause the specified
joint to fall.Ensure that the joint is
properly supported.
Do you want to continue?
```

- (4) The brake is released, and the specified joint moves manually.

NOTE



For the Jog keys operation, refer to *Operation: 2.1.4 Jog key*.

3. AUTO Mode

Switch the mode selector key switch to “Auto” to enter the AUTO mode.

AUTO mode is used for the automatic operation (executing programs) in the field running and state reference of the robot system.

Note, however, that the program cluster cannot be executed.

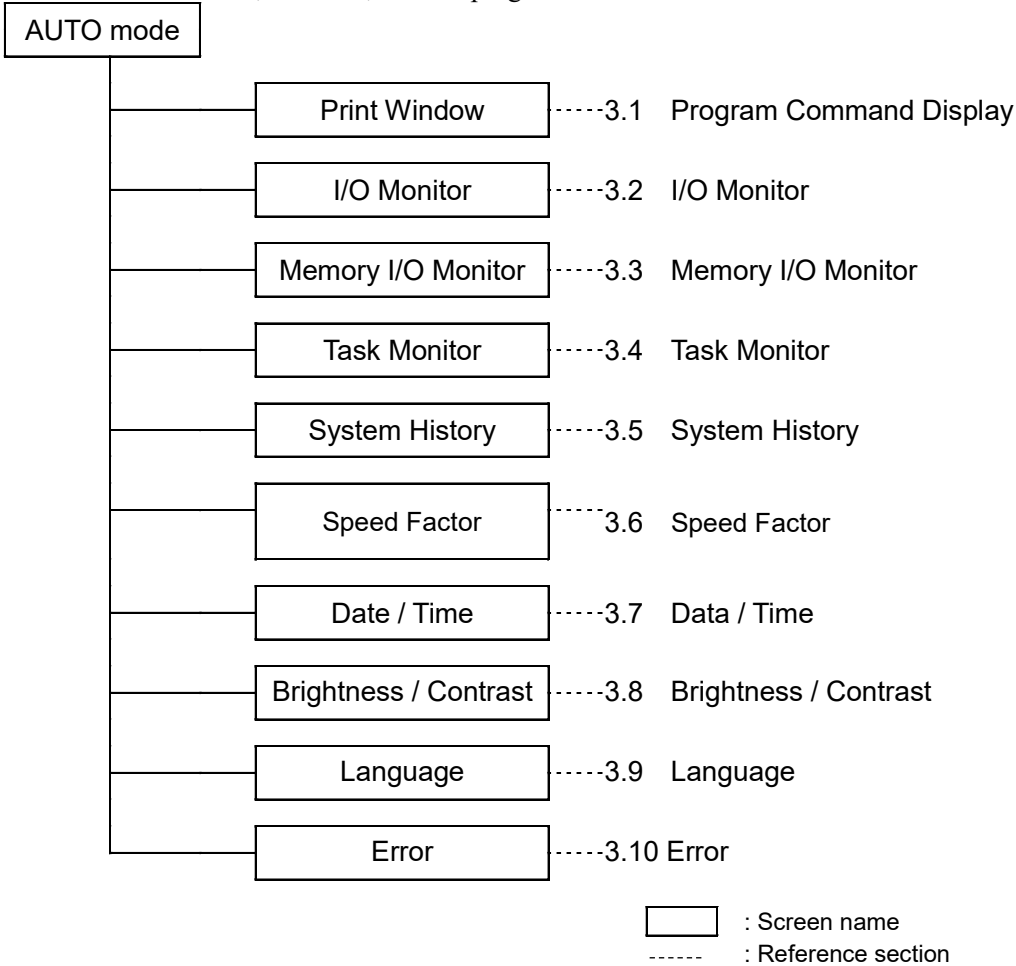

Switch the mode selector key switch to “Auto” to display the [Print] screen. Follow the description on the screen and press the <F4> key to display the [Main Menu] screen.

```

Main Menu
0 Print Panel
1 I/O Monitor
2 Memory I/O Monitor
3 Task Monitor
4 System History
5 Controller Status...
6 Date / Time
7 Brightness / Contrast
8 Language
  
```

3.1 Program Command Display

Display a message from the program or respond the request.

The [Print] screen appears when the mode selector key switch is switched to “Auto”.

To display the [Print] screen from the [Main Menu] screen, move the cursor to [0 Print Panel], and press the <OK> key.

When only a message appears

Program Example :

```
PRINT #24, "Test Print"
```



<F4> The [Main Menu] screen appears.

When a message appears and a response is requested

Program Example :

```
PRINT #24, "Test Print"
```

```
INPUT #24, a$
```



Input the response to the message at the cursor position. (Characters or numerical values)

<F1> Deletes all entered characters or numerical values.

3.2 I/O Monitor

This screen displays the bit status of I/O.

In the [Main Menu] screen, move the cursor to [1 I/O Monitor], and press the <OK> key.

Displays the item Bit #, Status # and label in this order from the left.

I/O status (Inputs, bit units)

The screenshot shows a terminal window titled "I/O Monitor". It displays a table of input statuses and a control bar at the bottom.

Bit#	Status	Label
0	Off	Sensor0
1	Off	Sensor1
2	Off	
3	Off	
4	Off	
5	Off	
6	Off	
7	Off	

At the bottom of the screen, there are three buttons: "Outputs", "Byte", and "Menu".

“*” (asterisk) is displayed before the label name for remote setting display to separate remote setting and I/O label.

- <F1> Switches between Inputs and Outputs.
- <F2> Switches the I/O status display (Bit units or Byte units).
- <F4> The [Main Menu] screen appears.

3.3 Memory I/O Monitor

This screen displays the bit status of memory I/O.

In the [Main Menu] screen, move the cursor to [2 Memory I/O Monitor], and press the <OK> key.

Displays the item Bit#, Status, and Label in this order from the left.

Memory I/O status (bit units)

The screenshot shows a terminal window titled "Memory I/O Monitor". It displays a table of memory I/O bit statuses.

Bit#	Status	Label
0	Off	Ready
1	Off	Busy
2	Off	
3	Off	
4	Off	
5	Off	
6	Off	
7	Off	

At the bottom of the screen, there are two buttons: "Byte" and "Menu".

- <F2> Switches the I/O status display (Bit units or Byte units).
- <F4> The [Main Menu] screen appears.

3.4 Task Monitor

This screen displays the status of tasks.

In the [Main Menu] screen, move the cursor to [3 Task Monitor], and press the <OK> key. Displays the item Number, Status, Type, Name, and CPU load factor (%) in this order from the left.

Task Monitor				
Normal Task				
#	Status	Type	Name	CPU
1	Wait	NOR	main	0
2	Run	NOR	TASK2	14
3	Run	NOR	TASK3	14
4				
5				
6				
7				
8				
9				
10				

Line BG TRAP Menu

When the task name is too long to display the whole name, a tilde is attached at the end of the task name as “LongTaskName_12345~”.

<F1> Displays the status and line number (Six digits) of all tasks in the program specified by the cursor.

Task Monitor				
Normal Task				
#	Line	Type	Name	CPU
1	000087	NOR	main	0
2	000193	NOR	TASK2	14
3	000198	NOR	TASK3	14
4				
5				
6				
7				
8				
9				
10				

Status BG TRAP Menu

<F2> Switches the task status display (Back ground task or Normal task).

Task Monitor				
BG Task				
#	Status	Type	Name	CPU
65	Run	BG	BgMain	14
66				
67				
68				
69				
70				
71				
72				
73				
74				

Line Normal TRAP Menu

<F3> Switches the task status display (Trap task or Back ground task).

Task Monitor					
TRAP Task					
#	Status	Type	Name	CPU	
257	Run	TRA	Task_Trap	19	
258	Run	TRA	Task_Trap2	19	
259					
260					
261					
262					
263					
264					
265					
266					

Line	Normal	BG	Menu
------	--------	----	------

Task numbers of the trap tasks correspond to trap type.

#257	Trap 1	#263	Trap Pause
#258	Trap 2	#264	Trap SGOpen
#259	Trap 3	#265	Trap SGClose
#260	Trap 4	#266	Trap Error
#261	Trap Finish	#267	Trap Emergency
#262	Trap Abort		

<F4> The [Main Menu] screen appears.

3.5 System History

This screen displays a history of errors, operations and warnings that occurred in the past. In the [Main Menu] screen, move the cursor to [4 System History], and press the <OK> key. Displays the item type, Number, Robot#, Joint #, Task #, Date, and Time in this order from the left.

[System History] main screen

System History						
Type	Num	R#	J#	T#	Date	Time
Event	5	0	0	1	08/24	12:11
Event	5	0	0	1	08/24	12:10
Event	5	0	0	1	08/24	12:09
Event	5	0	0	1	08/24	12:07
Event	5	0	0	1	08/24	12:02
Event	121	0	0	4097	08/24	12:02
Event	127	0	0	4097	08/24	12:02
Event	120	0	0	4097	08/24	12:02
Event	1	0	0	0	08/24	12:01
Event	2	0	0	0	08/24	12:01
Event	127	0	0	4097	08/24	12:00 ▼

Detail	Menu
--------	------

<F4> The [Main Menu] screen appears.

<F2> Displays the details of the error specified by the cursor.

```

System History
Num   :128           Type   :Event
Robot :0
Joint :0           Task #  :4097
Date  :08/24/09    Time    :12:12
Code1 :0           Code2   :0
Function:

Working mode changed to Teach.

Err List

```

3.6 Speed Factor

This screen is used to change the motion speed of robot motion commands (Go, Jump, Pulse, etc.) in a program.

- (1) In the [Main Menu] screen, move the cursor to [5 Speed Factor], and press the <OK> key.
- (2) The following screen will be displayed.

Enter the speed factor to the maximum speed (Unit: %, integer from 1 to 100).

Press the <Enter> key to confirm an input.

```

Speed Factor
Set speed factor:
Factor:100

Default

```

<F1> Returns to the default value (100).

- (3) Press the <OK> key to set the value.

3.7 Date / Time

This screen displays the Controller's date and time.

- (1) In the [Main Menu] screen, move the cursor to [6 Date / Time], and press the <OK> key.
- (2) Able to check the date and time.

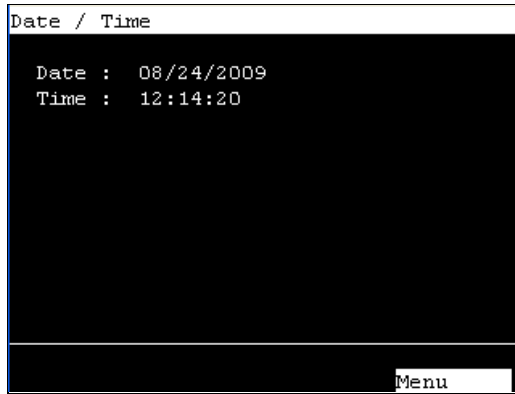

<F4> Returns to the [Main Menu] screen.

3.8 Brightness / Contrast

- (1) In the [Main Menu] screen, move the cursor to [7 Brightness / Contrast], and press the <OK> key.
- (2) Adjust the brightness and contrast. Press the <OK> key to save the status.



<↓><↑> These arrow keys can adjust the brightness.

<←><→> These arrow keys can adjust the contrast.

<F4> Returns to the [Main Menu] screen.

3.9 Language

- (1) In the [Main Menu] screen, move the cursor to [8 Language...] and press the <OK> key.
- (2) Move the cursor to the desired display language, and press the <OK> key.



The new display language setting is enabled after the next startup.

<F4> Returns to the [Main Menu] screen.

3.10 Error

Error # and Error message appears when an error occurs

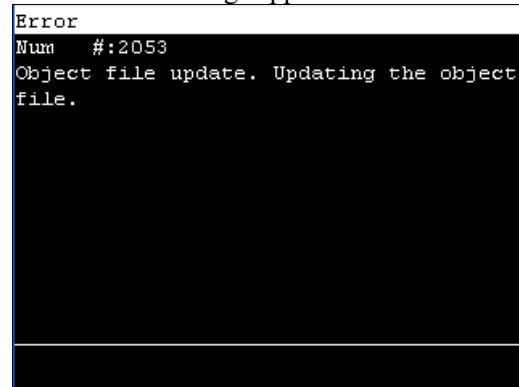

<OK> Moves to the screen before the error occurred.

4. TEST mode

To switch to TEST mode, switch the mode selector key switch to TEACH, and then select Function key F1: Test Mode in [Jog & Teach] screen of TEACH mode.

When the mode is switched to TEST, [Test mode] screen will be displayed.

Also, TEST mode LED on the front surface of the controller will be lit.



This mode enables program verification while the Enable Switch is held down and the safeguard is open.

This is a low speed program verification function (T1: manual deceleration mode) which is defined in Safety Standards.

This mode can execute the specified Function with multi-task / single-task, multi-manipulator / single-manipulator at low speed.

In TEST mode, program verification can be performed by either “single-task program verification”, or “multi-task program verification”.

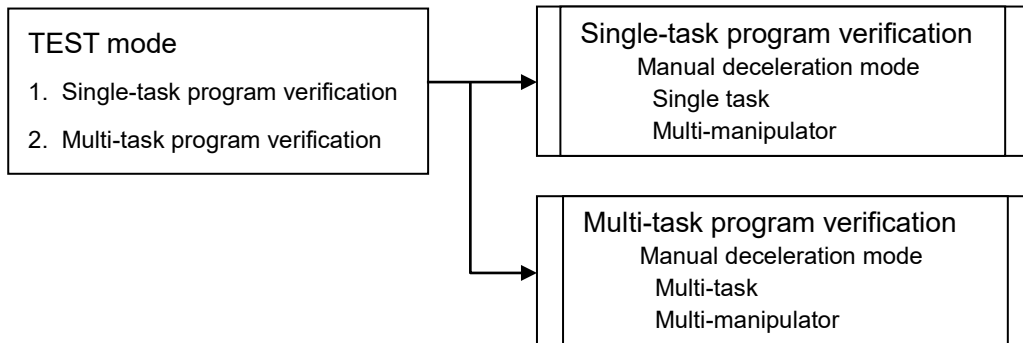

This product does not support a high-speed program verification function (T2: manual acceleration mode) defined in Safety Standards.

4.1 Single-task program verification

Single-task program verification is used to verify a program by checking motion of the robot and peripherals, by executing a single task with single- or multi-manipulators (Cycle / Step execution) with the safeguard open.

Function can be specified and executed within a speed limit and task execution limit.

An operator can execute a program while the operation key (Continue, Step In, Step Over, and Walk) is pressed and the Enable Switch is ON.

Running program can be paused by turning off the Enable Switch or releasing the operation key (Continue, Step In, Step Over, and Walk).

The operating robot stops by Quick Pause.

To resume the program, turn on the Enable Switch and press the operation key (Continue, Step In, Step Over, and Walk). The program will be resumed from the paused position.

The program execution aborts when the Emergency Switch is pressed or an error occurs.



The screen returns to [Program List Display].

The operating robot stops by Quick Pause.

The running program pauses according to Open/Close status of the safeguard.

To resume the program, release the latch status of the safeguard interlock. Then, turn on the Enable Switch and push the operation key (Continue, Step In, Step Over, and Walk).

The program will resume from the paused position.

 WARNING	<ul style="list-style-type: none"> ■ Before performing program verification, check that the robot system operates normally by using the EPSON RC+ debug function. <p>For details on the EPSON RC+ debug function, refer to the <i>EPSON RC+ User's Guide 5.11 [Run] Menu</i>.</p> <p>If debugging is insufficient, the robot may cause unintended motion. This is extremely hazardous and may cause serious bodily injury or severe damage to the robot.</p> <ul style="list-style-type: none"> ■ Before performing program verification, make sure that no one is in the robot's operation area. <p>The robot automatically starts moving as program verification is started. If the operator is in the robot's operation area, it is extremely hazardous and may cause serious bodily injury or severe damage to the robot.</p>
 CAUTION	<ul style="list-style-type: none"> ■ When abnormal operation such as collision with peripherals is predicted, release the operation key (Continue, Step In, Step Over, and Walk) immediately and stop the robot. The robot also can be stopped by turning off the Enable Switch, or push the switch harder. ■ After performing program verification, be sure to follow the points below: <ul style="list-style-type: none"> - Check the changed parts in software before supplying power. - Perform function test to check whether the robot system operates normally.

In the TEST mode, a program cannot be changed.

To change the point data, switch to TEACH mode and move the robot to the desired position by Jog operation or direct teaching.

Teach the desired robot position to the specific point number.

For details on Jog operation, refer to *1.1 Jog Operation*.

For details on direct teaching, refer to *1.3 Direct Teaching*.

For details on teaching, refer to *1.2 Teaching*.

Task Behavior during Single Task Program Verification

Background tasks stop when switching the mode to the TEST mode.

The tasks resume when switching to the TEACH mode.

Behavior of Events and Tasks

Event	Task Type			Background Task
	Normal	NoPause	NoEmgAbort	
Enable Switch OFF	Pause	- *1	- *1	- *2
Operation key is OFF (Continue, Step In, Step Over, and Walk)	Pause	- *1	- *1	- *2
STOP key is pressed	Abort	- *1	- *1	- *2
Change Open/Close status of the Safety Door	Pause	- *1	- *1	- *2
Error during a test	Abort	- *1	- *1	- *2
Emergency stop	Abort	- *1	- *1	- *2
Switch to TEACH mode	Abort	- *1	- *1	- *2

*1 Xqt task types (NoPause, NoEmgAbort) cannot be executed.

If these tasks are specified, they are performed program verification as normal tasks.

*2 If background tasks are specified, they are performed program verification as normal tasks.

Available Function

Functions without parameters

Functions with source not hidden

Robot Motion Speed Designation

During program verification, robots always operate in Low power mode.

Low power mode:

Speed lower than 250 mm/sec

Restrains the motor power output

[Speed] can be changed within a range specified for Low power mode by pressing the <Speed> key.

Low: 25% of speed for Low power mode

Middle: 50% of speed for Low power mode

High: 100% of speed for Low power mode

 CAUTION	<p>■ The faster the speed, the longer the stopping distance at the timing of emergency stop or pause is. When operating a robot where interference with peripheral equipment is predictable, perform program verification at the low speed, taking the stopping distance into consideration.</p>
---	--

Execution-restraint Functions and Commands

Power High	Power mode is always set to Low. Specification function cannot be executed.
TRAP	Corresponding task cannot be executed even when a condition is met.
XQT	An error occurs, and the program execution will be aborted.
INPUT	Input from the console causes an error and aborts the program execution.
PRINT #24	Output to the Teach Pendant causes an error and aborts the program execution.

4.2 Multi-task Program Verification

Multi-task program verification is used to verify a program by checking motion of the robot and peripherals, by executing a multi tasks with single- or multi-manipulators (Cycle / Step execution) with the safeguard open.

Function can be specified and executed within a speed limit and task execution limit.

An operator can execute a program while the operation key (Continue) is pressed and the Enable Switch is ON.

Running program can be paused by turning off the Enable Switch or releasing the operation key (Continue).

The operating robot stops by Quick Pause.

To resume the program, turn on the Enable Switch and press the operation key (Continue).

The program will be resumed from the paused position.

The program execution aborts when the Emergency Switch is pressed or an error occurs.

The screen returns to [Program List Display].

The operating robot stops by Quick Pause.

The running program pauses according to Open/Close status of the safeguard.

To resume the program, release the latch status of the safeguard interlock. Then, turn on the Enable Switch and push the operation key (Continue). The program will resume from the paused position.

 WARNING	<ul style="list-style-type: none"> ■ Before performing program verification, check that the robot system operates normally by using the EPSON RC+ debug function. <p>For details on the EPSON RC+ debug function, refer to the <i>EPSON RC+ User's Guide 5.11 [Run] Menu</i>.</p> <p>If debugging is insufficient, the robot may cause unintended motion. This is extremely hazardous and may cause serious bodily injury or severe damage to the robot.</p> <ul style="list-style-type: none"> ■ Before performing program verification, make sure that no one is in the robot's operation area. <p>The robot automatically starts moving as program verification is started. If the operator is in the robot's operation area, it is extremely hazardous and may cause serious bodily injury or severe damage to the robot.</p>
---	---

 CAUTION	<ul style="list-style-type: none"> ■ When abnormal operation such as collision with peripherals is predicted, release the operation key (Continue, Step In, Step Over, and Walk) immediately and stop the robot. The robot also can be stopped by turning off the Enable Switch, or push the switch harder. ■ After performing program verification, be sure to follow the points below: <ul style="list-style-type: none"> - Check the changed parts in software before supplying power. - Perform function test to check whether the robot system operates normally.
---	---

In the TEST mode, a program cannot be changed.

To change the point data, switch to TEACH mode and move the robot to the desired position by Jog operation or direct teaching.

Teach the desired robot position to the specific point number.

For details on Jog operation, refer to *1.1 Jog Operation*.

For details on direct teaching, refer to *1.3 Direct Teaching*.

For details on teaching, refer to *1.2 Teaching*.

Task Behavior during Multi-Task Program Verification

Background tasks stop when switching the mode to the TEST mode. The tasks run automatically at the start of program verification and are performed program verification along with specified normal tasks.

These tasks stop when the multi-program verification is stopped and resume resume when switching to the TEACH mode.

Behavior of Events and Tasks

Event	Task Type			Background Task Normal
	Normal	NoPause	NoEmgAbort	
Enable Switch is OFF	Pause	Pause	Continue	Continue
Operation key is OFF (Continue)	Pause	Pause	Continue	Continue
STOP key is pressed	Abort	Abort	Abort	Abort
Change Open/Close status of the Safety Door	Pause	Pause	Continue	Continue
Error during a test	Abort	Abort	Abort	Abort
Emergency stop	Abort	Abort	Continue	Abort
Switch to TEACH mode	Abort	Abort	Abort	Continue/Resume

Available Function

Functions without parameters

Functions with source not hidden

Robot Motion Speed Designation

During program verification, robots always operate in Low power mode.

Low power mode:

Speed lower than 250 mm/sec

Restrains the motor power output

[Speed] can be changed within a range specified for Low power mode by pressing the <Speed> key.

Low: 25% of speed for Low power mode

Middle: 50% of speed for Low power mode

High: 100% of speed for Low power mode

 CAUTION	<ul style="list-style-type: none"> ■ The faster the speed, the longer the stopping distance at the timing of emergency stop or pause is. When operating a robot where interference with peripheral equipment is predictable, perform program verification at the low speed, taking the stopping distance into consideration.
---	---

Execution-restraint Functions and Commands

Power High	Power mode is always set to Low. Specification function cannot be executed.
INPUT	Input from the console causes an error and aborts the program execution.
PRINT #24	Output to the Teach Pendant causes an error and aborts the program execution.

4.3 Test mode

This screen is used to select TEST mode.

Move the cursor to [Single-task program verification] or [Multi-task program verification], and press the <OK> key.



<F4><F8> Returns to [Jog & Teach] screen.

4.4 Function

This screen is used to select the Function to perform program verification.

If there are several project files, a project file list will be displayed in [Selection File] screen. Move the cursor to the project file which has a Function to perform project verification and press the <OK> key.

If there is only one project file, [Selection File] screen will not be displayed.

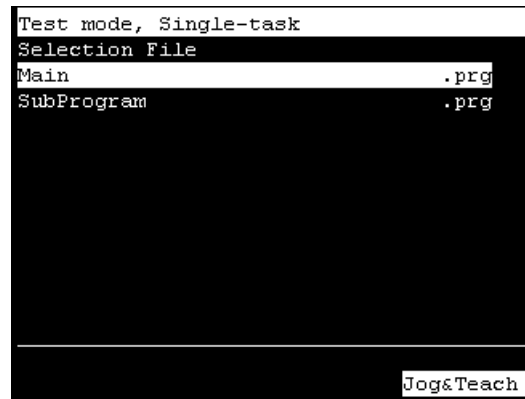

<F4><F8> Returns to [Jog & Teach] screen.

After selecting the project file, the Function list will be displayed in [Selection Function] screen. Move the cursor to the Function to perform program verification and press the <OK> key.

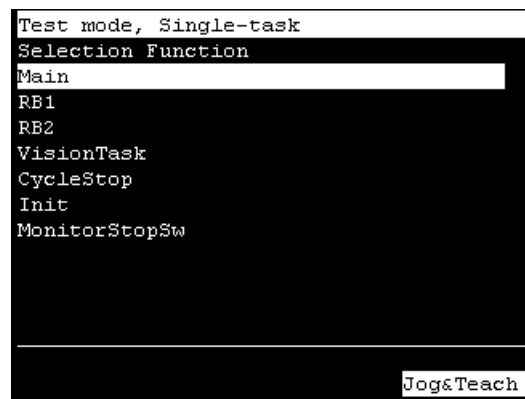

<F4><F8> Returns to [Jog & Teach] screen.

4.5 Program List Display

The program list for selected Function is displayed.

Check that the Function to perform program verification is surely selected.

```

Test mode, Single-task  Robot   : 01
File   : Main.prg      Speed   : Low
Function : Main        Line 3 : 264
_unction Main|
  Call Init           ' Initializati▶
  Wait 1              ' Conveyer ope▶
  Xqt VisionTask     ' Vision task ▶
  Wait MemSw(VisionReady) = On    ' ▶
  ↓
  MemOff StopRB1|
  ↓
  Xqt MonitorStopSw 'Stop SW Monit▶
  ↓
  Start
  Jog&Teach
    
```

Cursor movement

The mode can be switched by On/ Off of “F5-8”.

To turn On or Off “F5-8”, press the <F1-4 / F5-8> key.

F5-8	Mode	Key	Function
Off	Normal	↑	Moves the cursor up
		↓	Moves the cursor down
		←	Moves the cursor to the left
		→	Moves the cursor to the right
On	Scroll	⤴	Moves to the previous page
		⤵	Moves to the next page
		<<	Moves to the right side page
		>>	Moves to the left side page

<F1> Moves to [Program verification] screen.

<F4><F8> Returns to [Jog & Teach] screen.

After confirming that the Function to perform program verification is surely selected, press the <F1> key and perform program verification.

4.6 Program Verification

The cursor is displayed on the first line of the specified Function.

Program starts from the line with the cursor.

4.6.1 Single-task program verification screen

Program can be executed while the operation switch (Continue, Step In, Step Over, and Walk) is pressed when the Enable Switch is ON.

Running program can be paused by turning off the Enable Switch or releasing the operation key (Continue, Step In, Step Over, and Walk).

The operating robot stops by Quick Pause.

To resume the program, turn on the Enable Switch and press the operation key (Continue, Step In, Step Over, and Walk). The program will be resumed from the paused position.

The program execution aborts when the Emergency Switch is pressed or an error occurs.

The screen returns to [Program List Display].

The operating robot stops by Quick Pause.

The running program pauses according to Open/Close status of the safeguard.

To resume the program, release the latch status of the safeguard interlock. And then, turn on the Enable Switch and push the operation key (Continue, Step In, Step Over, and Walk). The program will resume from the paused position.

```

Test mode, Single-task  Robot  : 01
File   : Main.prg      Speed  :Low
Function : Main        Line 3 : 264
Function Main
  Call Init          ' Initialization
  Wait 1             ' Convayer oper▶
  Xqt VisionTask    ' Vision task s▶
  Wait MemSw(VisionReady) = On    ' V▶

  MemOff StopRB1

  Xqt MonitorStopSw 'Stop SW Monito▶
  
```

Continue Stop

When <F5-8> key is pressed, “F5-8” lamp will turn on and function key display will be switched.

```

Test mode, Single-task  Robot  : 01
File   : Main.prg      Speed  :Low
Function : Main        Line 3 : 264
Function Main
  Call Init          ' Initialization
  Wait 1             ' Convayer oper▶
  Xqt VisionTask    ' Vision task s▶
  Wait MemSw(VisionReady) = On    ' V▶

  MemOff StopRB1

  Xqt MonitorStopSw 'Stop SW Monito▶
  
```

StepIn StepOver Walk

- <F1> Executes a program in Cycle mode.
- <F4> Stops program verification. Returns to [Program list display] screen.
- <F5> Executes a program in STEP mode [Step In]
- <F6> Executes a program in STEP mode [Step Over]
- <F7> Executes a program in Walk [Walk].

4.6.2 Multi-task program verification screen

Program can be executed while the operation switch (Continue) is pressed when the Enable Switch is ON.

Running program can be paused by turning off the Enable Switch or releasing the operation key (Continue).

The operating robot stops by Quick Pause.

To resume the program, turn on the Enable Switch and press the operation key (Continue).

The program will be resumed from the paused position.

The program execution aborts when the Emergency Switch is pressed or an error occurs.

The screen returns to [Program List Display].

The operating robot stops by Quick Pause.

The running program pauses according to Open/Close status of the safeguard.

To resume the program, release the latch status of the safeguard interlock. Then, turn on the Enable Switch and push the operation key (Continue). The program will resume from the paused position.

```

Test mode, Multi-task  Robot : 01
File      : Main.prg   Speed :Low
Function : Main        Line 3 : 264
Function Main
  Call Init           ' Initialization
  Wait 1              ' Conveyer oper▶
  Xqt VisionTask     ' Vision task s▶
  Wait MemSw(VisionReady) = On    ' V▶

  MemOff StopRB1

  Xqt MonitorStopSw  'Stop SW Monito▶

```

Continue Stop

<F1> Executes a program in Cycle mode.

<F4> Stops program verification. Returns to [Program list display] screen.

4.6.3 Continue

<F1> key

Executes the Function. Paused task will start from the current line.

4.6.4 Step In

<F5> key

Executes the current line of the paused task and stops at the next line. If the current line is a function call, the program pauses at the first line of the called function.

This key is available in single-task program verification.

4.6.5 Step Out

<F6> key

Executes the current line of the paused task and stops at the next line. If the current line is a function call, the program pauses when all tasks of the called function are executed.

This key is available in single-task program verification.

4.6.6 Walk

<F7> key

Executes a program until next motion command or output command, and stops at the next line. Whether to stop at the output command can be set by checking the [Walk stops for output commands] check box in the EPSON RC+-[Set up]-[System Configuration]-[Controller]-[General] tab.

This key is available in single-task program verification.

4.6.7 Run Window (TEST mode)

In TEST mode, the Run window can be displayed to display Print output data.

To display the Run window, select the EPSON RC+- menu-[Run]-[Run window].

Execution, pause, stop, and continue of a program is not available in Run Window (TEST mode).

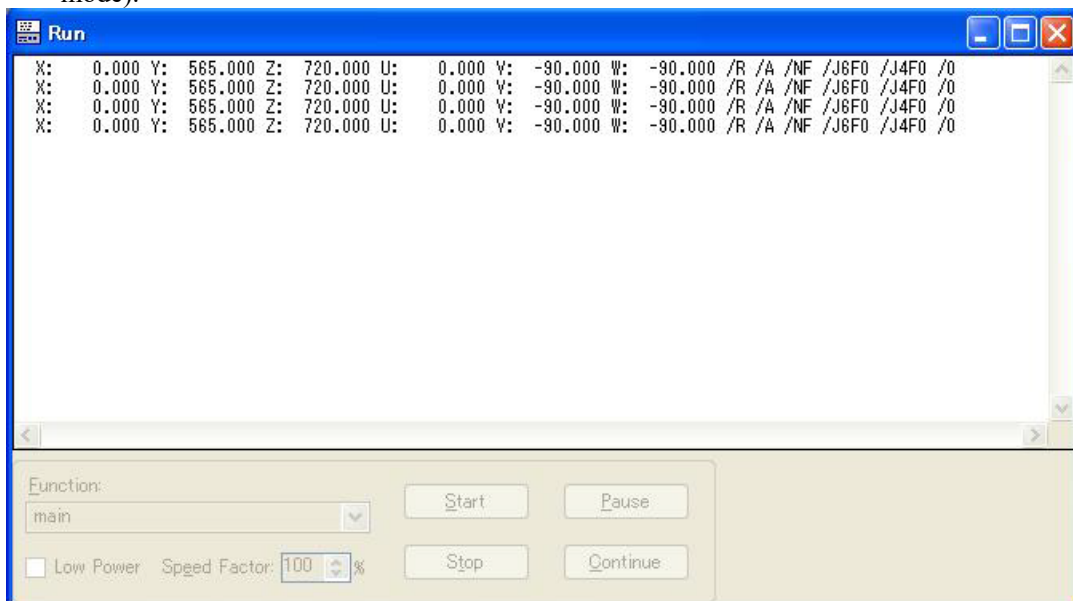

4.6.8 I/O monitor (TEST mode)

In TEST mode, the EPSON RC+ I/O Monitor dialog can be displayed to monitor I/O status. To display the I/O Monitor dialog, select the EPSON RC+ -menu -[Tools]-[I/O Monitor]. I/O cannot be changed from the I/O Monitor (TEST mode).

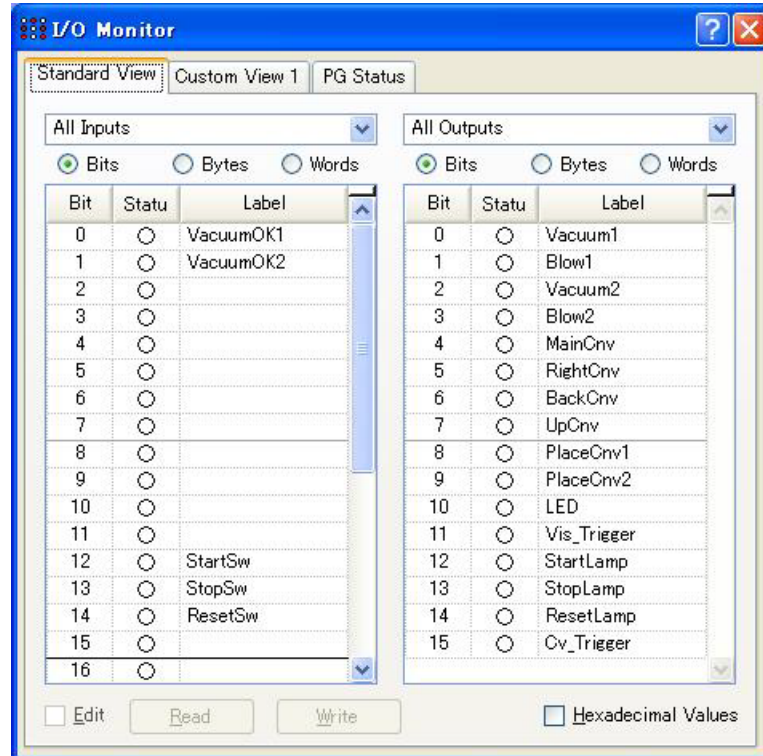

4.6.9 Variables (TEST mode)

In TEST mode, the EPSON RC+ [Variables] dialog can be displayed to monitor variables. To display the Variables dialog, select the EPSON RC+-menu-[Run]-[Display Variables]. Variables cannot be changed from the Variables monitor (TEST mode).

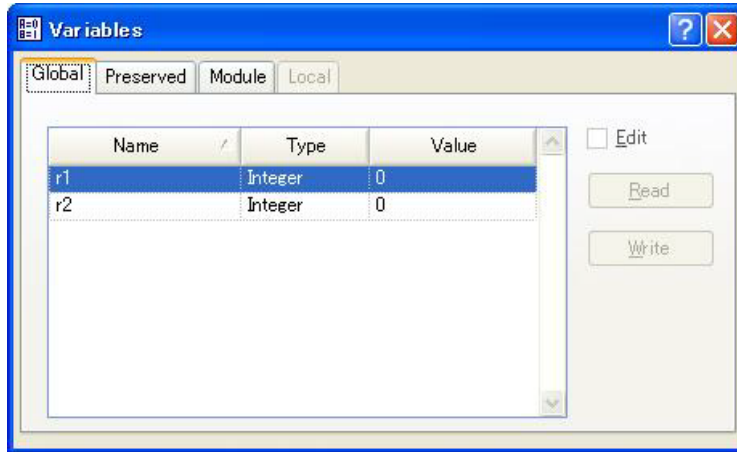

4.6.10 Task Manager (TEST mode)

In TEST mode, the EPSON RC+ Task Manager dialog can be displayed to monitor the task status.

To display the Task Manager dialog, select the EPSON RC+-menu-[Tools]-[Task Manager]. Halt (pause), Resume (continue), and Quit (end) of tasks cannot be executed from the Task Manager (TEST mode).

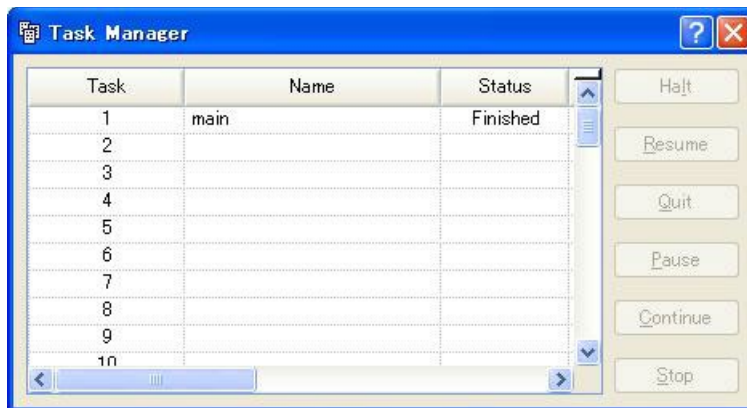

4.7 Error

When an error occurs, file name, execution line number, error number, and error message will be displayed.

```
Error
Num      #:5041
Robot    #:01
Joint    #:01
File     :Main.prg
Function :C3_A601S
Line     #:749
Message  :

Motor torque output failure in low
power state. Check the power cable
connection, robot, brake, driver, or
motor.
```

<OK> Moves to [Program display] screen.

5. Password Setup

Setup a password to limit operators for the brake equipment (6-axis robot only).

TEACH mode [Jog&Teach]-[Brake] 6-Axis robot only

Follow the procedure below to set the password.

- (1) Select EPSON RC+-menu-[Setup]-[System Configuration]-[SPEL Controller Board]-[Configuration] to display the following screen.

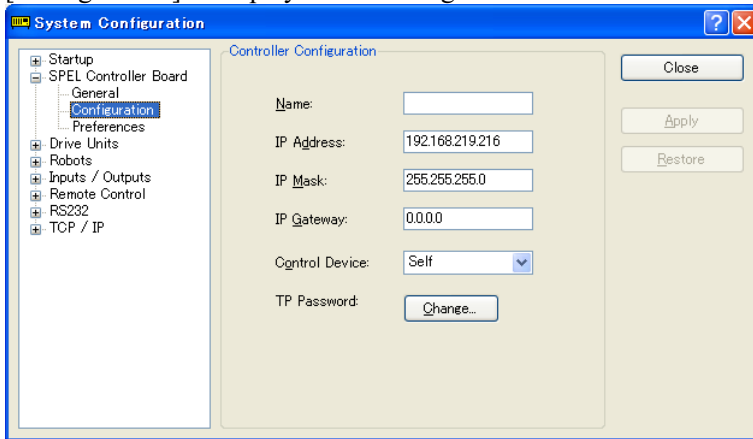

- (2) Click the <Change> button at “TP Password.”

- (3) The following dialog appears.

Enter a password within 16 alphanumeric characters from the keyboard and click the <OK> button.



- (4) Click the <Apply> button and reboot the Controller.

6. Troubleshooting

If the condition does not change after performing the countermeasure above, the unit may have suffered a breakdown.

Please contact the service center or the manufacturer.

Display panel is blank

- The Controller supplies DC24V.
Check that the Controller is ON.
- Check that the Controller is connected to the TP port of the Controller properly.

An Error code appears and the Robot does not operate normally

- Please refer to the error code indicated in the following manual.
Status Code / Error Code List

Robot does not move by pressing the Jog key

- Execute the Motor On command to energize the Robot motor.
(Refer to *Motor On in the EPSON RC+ SPEL+ Language Reference*)
- Energize the Robot motor.
(Refer to *SLock in the EPSON RC+ SPEL+ Language Reference*)
- Short jog distance may be selected.
Check the value in the [Jog Distance] screen and change the setting to long distance if needed.
(Refer to *Setup & Operation 2.6 Jog Distance*)

Operation mode does not switch from TEACH mode to AUTO mode

- Send the latch release input signal to release the latch status.

Program list is not displayed in program verification window of TEST mode

- Check for the setting whether it is set to store execution source files to the Controller.
Settings can be confirmed by following steps:
Select EPSON RC+ menu- [Project]-[Properties]-[Source Files In Controller] and check if desired files are checked in [Select source files to store in controller:].

Robot motion will is slow after switching the mode from TEACH to AUTO

Refer to the NOTE in the following section:

Operation: 1. Teaching Procedure

7. Maintenance Parts List

Part Name	Code	Old Code	Note
Key	2122205	R13B060901	Mode selector key

8. Option Parts List

Part Name	Code	Old Code	Note
Wall Bracket	R12NZ9005M	R12B120105	
Conversion Kit	R12NZ9005N	R12B120111	CK1
TP Exchange Cable	0.5 m	R12NZ900L6	-
Extension Cable	5 m	R12NZ90111	-
	10 m	R12NZ900NJ	-
	15 m	R12NZ900NK	-
Hot Plug Kit	R12N2900NL	-	For RC700-A controller